



US00RE43096E

(19) **United States**  
 (12) **Reissued Patent**  
**Smith et al.**

(10) **Patent Number:** **US RE43,096 E**  
 (45) **Date of Reissued Patent:** **Jan. 10, 2012**

(54) **TAGGED EXTENDABLE PRIMERS AND EXTENSION PRODUCTS**  
 (75) Inventors: **Lloyd M. Smith**, Madison, WI (US);  
**Leroy E. Hood**, Seattle, WA (US);  
**Michael W. Hunkapiller**, San Carlos, CA (US);  
**Timothy Hunkapiller**, Mercer Island, WA (US);  
**Charles R. Connell**, Redwood City, CA (US)

(73) Assignee: **California Institute of Technology**, Pasadena, CA (US)

(21) Appl. No.: **10/389,663**

(22) Filed: **Mar. 13, 2003**

**Related U.S. Patent Documents**

Reissue of:

(64) Patent No.: **6,200,748**  
 Issued: **Mar. 13, 2001**  
 Appl. No.: **08/484,340**  
 Filed: **Jun. 7, 1995**

U.S. Applications:

(63) Continuation of application No. 08/361,176, filed on Dec. 21, 1994, now Pat. No. 5,821,058, which is a continuation of application No. 07/898,019, filed on Jun. 12, 1992, now abandoned, which is a continuation of application No. 07/660,160, filed on Feb. 21, 1991, now abandoned, which is a continuation of application No. 07/106,232, filed on Oct. 7, 1987, now abandoned, which is a continuation-in-part of application No. 06/722,742, filed on Apr. 11, 1985, now abandoned, which is a continuation-in-part of application No. 06/689,013, filed on Jan. 2, 1985, now abandoned, which is a continuation-in-part of application No. 06/570,973, filed on Jan. 16, 1984, now abandoned.

(51) **Int. Cl.**  
**C12Q 1/68** (2006.01)  
**G01N 27/447** (2006.01)  
 (52) **U.S. Cl.** ..... **435/6.1**; 536/24.3; 536/25.32;  
 536/26.6; 435/91.2; 435/91.1; 435/91.51  
 (58) **Field of Classification Search** ..... 435/6, 91.2;  
 536/24.33, 23.1, 24.3, 26.6  
 See application file for complete search history.

(56) **References Cited**

**U.S. PATENT DOCUMENTS**

3,906,031 A 9/1975 Carpino et al. .... 560/32  
 4,119,521 A 10/1978 Chirikjian  
 4,151,065 A 4/1979 Kaplan et al.  
 4,318,846 A 3/1982 Khanna et al.  
 4,373,071 A 2/1983 Itakura ..... 525/375  
 4,375,401 A 3/1983 Catsimpoalas  
 4,401,796 A 8/1983 Itakura ..... 525/340  
 4,415,732 A 11/1983 Caruthers et al.  
 4,474,948 A 10/1984 Hudson et al.  
 4,483,964 A 11/1984 Urdea et al.  
 4,500,707 A 2/1985 Caruthers et al.  
 4,517,338 A 5/1985 Urdea et al.  
 4,534,647 A 8/1985 Gross et al.  
 4,598,049 A 7/1986 Zelinka et al.  
 4,605,735 A 8/1986 Miyoshi et al.  
 4,667,025 A 5/1987 Miyoshi et al.

4,668,777 A 5/1987 Caruthers et al. .... 536/26.5  
 4,711,955 A 12/1987 Ward et al.  
 4,721,499 A 1/1988 Marx et al.  
 4,721,500 A 1/1988 Van Handel et al.  
 4,757,141 A 7/1988 Fung et al.  
 4,849,513 A 7/1989 Smith et al.  
 4,855,225 A 8/1989 Fung et al.  
 4,948,882 A 8/1990 Ruth ..... 536/25.32  
 5,015,733 A 5/1991 Smith et al.  
 5,118,800 A 6/1992 Smith et al.  
 5,118,802 A 6/1992 Smith et al.  
 5,162,654 A 11/1992 Kostichka et al.  
 5,171,534 A 12/1992 Smith et al.  
 5,188,934 A \* 2/1993 Menchen et al. .... 435/6  
 5,212,304 A 5/1993 Fung et al.  
 5,241,060 A \* 8/1993 Engelhardt et al. .... 536/25.32  
 5,258,538 A 11/1993 Fung et al.  
 5,260,433 A 11/1993 Engelhardt et al. .... 536/23.1  
 5,366,860 A 11/1994 Bergot et al.  
 5,541,313 A 7/1996 Ruth ..... 536/24.3  
 5,688,655 A 11/1997 Housey  
 5,821,058 A 10/1998 Smith et al.  
 5,935,783 A 8/1999 Gong et al.  
 6,992,180 B1 1/2006 Engelhardt et al.  
 7,220,854 B1 5/2007 Engelhardt et al.  
 2002/0123046 A1 9/2002 Smith et al.

**FOREIGN PATENT DOCUMENTS**

EP 0 070 685 A2 \* 7/1982

(Continued)

**OTHER PUBLICATIONS**

Augustin et al (J. Biotechnol. (2001) 86 :289-301.\*  
 Levinson et al. BBA 447:260-273, Oct. 1976.\*  
 Hindley et al. Proc. FEBS Symp: DNA-Recombination Interactions and Repair. Pergamon Press, New York, pp. 143-154, 1980.\*  
 Tsuchiya, M. (1982) "Development of DNA fluorescent labeling and Real-Time Fluorescence Detection Gel Electrophoresis Methods," Biophysics 22:2170.\*  
 Kitamura et al. V77(6):3196-3200 Proc. Natl. Acad. Sci., Jun. 1980.\*  
 Leary et al. Proc. Natl. Acad. Sci. 80:4045-4049, Jul. 1983.\*  
 Langer et al. Proc. Natl. Acad. Sci. 78:6633-6637, Nov. 1981.\*  
 Todorov et al. (Optical and Quantum Electronics 1981, vol. 13, p. 209-215).\*  
 Das et al. (J. of Virol., 1976, 20(1):70-77).\*  
 Tsuchiya et al. (Translation of Master Thesis, Feb. 2, 1983, p. 1-8, IDS reference).\*  
 Yoshioka et al. (Saibo Kogaku [Cell Engineering], vol. 1, no. 1, 1982, 79(93)-87(101), IDS reference).\*

(Continued)

*Primary Examiner* — Stephanie K Mummert

(74) *Attorney, Agent, or Firm* — James S. Keddie; Carol L. Francis; Bozicevic, Field & Francis, LLP

(57) **ABSTRACT**

This invention provides a duplex comprising an oligonucleotide primer and a template, wherein the primer is coupled chemically to a chromophore or fluorophore so as to allow chain extension by a polymerase. In one embodiment, the primer is extended by a polymerase to generate the complement of the template. In a further embodiment, the extended primer is separated from the template for use in a number of methods, including sequencing reactions. Methods of generating these compositions of matter are further provided.

**97 Claims, 6 Drawing Sheets**

## FOREIGN PATENT DOCUMENTS

EP	0 070 685	B1 *	7/1982
EP	0063879		10/1982
EP	0068875		1/1983
EP	070687		1/1983
EP	0090789		10/1983
EP	097341		1/1984
EP	0097373	A2	1/1984
EP	0261283		4/1995
GB	2153356		8/1985
JP	49-126395		12/1974
JP	57-209297		12/1982
JP	58-502205		12/1983
JP	59-44648		3/1984
JP	59-93100		5/1984
JP	59-126252	*	7/1984
JP	60-161559	*	8/1985
JP	60-242368	*	12/1985
WO	WO 83/02277		7/1983
WO	WO 83/03260		9/1983
WO	WO 86/06726		11/1986
WO	WO 86/07361		12/1986

## OTHER PUBLICATIONS

Prober et al., "A system for rapid DNA sequencing with fluorescent chain-terminating dideoxynucleotides" *Science* (1987) 238:336-341.

Brumbaugh et al., "Continuous, on-line DNA sequencing using oligodeoxynucleotide primers with multiple fluorophores" *Proc. Natl. Acad. Sci. USA* (1988) 85:5610-5614.

Matthews et al., "Analytical strategies for the use of DNA probes" *Anal. Biochem.* (1988) 169:1-25.

Barrio, J.R. et al., "Fluorescent adenosine and cytidine derivatives" *Biochem. Biophys. Res. Comm.* (1972) 46(2):597-604.

Eshaghpour, H et al., "Specific chemical labeling of DNA fragments" *Nucl. Acids Res.* (1979) 7(6):1485-1495.

Fiddes et al., "Isolation, cloning and sequence analysis of cDNA for the I-subunit of human chorionic gonadotropin" *Nature* (1979) 281:351-356.

Guo et al., "New rapid methods for DNA sequencing based on exonuclease III digestion followed by repair synthesis" *Chem. Abstr.* (1982) 97:162 (abstract No. 1521k).

Husimi, Y., "DNA Sequencer" *Oyo Buturi* (1982) 51(12):1400.

Husimi, Y. et al., "Automation and Testing of DNA Base Sequence Determination Methods" *Development of Physical Means of Measurement and Software for Informed Macromolecular Analysis* (Mar. 1984) pp. 20-25.

Secrist, J.A. et al., "Fluorescent modification of adenosine 3',5'-monophosphate: Spectroscopic properties and activity in enzyme systems" *Science* (1972) 175:279-280.

Stanley et al., "A different approach to RNA sequencing" *Nature* (1978) 274:87-89.

Tsuchiya, M. et al., "Developments of DNA fluorescent labeling and real-time fluorescent detection gel electrophoresis methods" *Biophysics* (1982) 22:2-E-19.

Ulanov et al., "Electron microscopic determination of guanosine localization in DNA" *Chem Abstr.* (1967) 67:1692 (abstract No. 17910c).

Wada, A., "DNA" *Japan Science and Technology* (1983) 24(#221):84-91.

Cotrufo et al., "High sensitivity method for fluorophore detection in gradient polyacrylamide slab gels through excitation by laser light: Application to glycoproteins stained with concanavalin A-fluorescein isothiocyanate" *Anal. Biochem.* (1983) 134:313-319.

Gilbert, "DNA-sequenzierung und gen-struktur (Nobel-Vortrag)" *Angewandte Chemie* (1981) 93:1037-1046.

Maxam et al., "A new method for sequencing DNA" *Proc. Natl. Acad. Sci. USA* (1977) 74:560-564.

Maxam et al., "Sequencing end-labeled DNA with base-specific chemical cleavages" *Meth Enzymol.* (1980) 65:499-559.

Gill et al., "New developments in chemiluminescence research" *Aldrichimica Acta* (1983) 16:59-61.

Mellbin, "A chemiluminescence detector for trace determination of fluorescent compounds" *J. Liq. Chrom.* (1983) 6:1603-1616.

Sanger et al., "DNA sequencing with chain-terminating inhibitors" *Proc. Natl. Acad. Sci. USA* (1977) 74:5463-5467.

Smith, "DNA sequence analysis by primed synthesis" *Meth. Enzymol.* (1980) 65:560-580.

Smith et al., "The synthesis of oligonucleotides containing an aliphatic amino group at the 5' terminus: Synthesis of fluorescent DNA primers for use in DNA sequence analysis" *Nucl. Acids Res.* (1985) 13:2399-2412.

Dörper et al., "Improvements in the phosphoramidite procedure for the synthesis of oligodeoxyribonucleotides" *Nucl. Acids Res.* (1983) 11:2575-2584.

Langer et al., "Enzymatic synthesis of biotin-labeled polynucleotides: Novel nucleic acid affinity probes" *Proc. Natl. Acad. Sci. USA* (1981) 78:6633-6637.

Titus et al., "Texas red, a hydrophilic, red-emitting fluorophore for use with fluorescein in dual parameter flow microfluorometric and fluorescence microscopic studies" *J. Immunol. Meth.* (1982) 50:193-204.

Dialog™ English abstract of Japanese Patent Publication No. 60-161559 (Aug. 23, 1985).

Dialog™ English abstract of Japanese Patent Publication No. 60-242368 (Dec. 2, 1985).

Dialog™ English abstract of Japanese Patent Publication No. 59-126252 (Jul. 20, 1984).

Tsuchiya, M., "Fluorescence labelling of DNA and development of a real-time fluorescence detection gel electrophoresis method." *Abstract for Master's Thesis. Saitama University* (1983).

Kagakukai ed., "Fluorescence tagging" *Biochemistry Experiments Course 2. Nucleic Acid Chemistry III* (1977) pp. 299-317.

Yang et al., "Studies of transfer RNA tertiary structure by singlet-singlet energy transfer" *Proc. Natl. Acad. Sci. USA* (1974) 71(7):2838-2842.

Yoshioka et al., "Method for determining a DNA nucleotide sequence. I" *Cell Engineering* (1982) 1(1):93-101.

Lee et al., "Transcription of adenovirus type 2 genes in a cell-free system: Apparent heterogeneity of initiation at some promoters" *Molecular and Cellular Biology* (1981) 1(7):635-651.

Nomiyama et al., "Method for determining a DNA nucleotide sequence. II" *Cell Engineering* (1982) 1(2):105-115.

Draper et al., "A method for linking fluorescent labels to polynucleotides: Application to studies of ribosome-ribonucleic acid interactions" *Biochemistry* (1980) 19(9):1774-1781.

Bauman et al., "A new method for fluorescence microscopical localization of specific DNA sequences by in situ hybridization of fluorochrome-labelled RNA" *Exp. Cell Res.* (1980) 128:485-490.

Douglass et al., "Methods and instrumentation for fluorescence quantitation of proteins and DNA's in electrophoresis gels at the 1 ng level" in *Electrophoresis '78*, N. Catsimpoólas, ed. (1978) pp. 155-165.

Bouloy, M. et al., "Cap and internal nucleotides of reovirus mRNA primers are incorporated into influenza viral complementary RNA during transcription in vitro" *Journal of Virology* (1979) 32(3):895-904.

Plotch, S.J. et al., "Transfer of 5'-terminal cap of globin mRNA to influenza viral complementary RNA during transcription in vitro" *Proceedings the National Academy of Science USA* (1979) 76(4):1618-1622.

Brumbaugh et al., "Continuous, on-line DNA sequencing using oligodeoxynucleotide primers with multiple fluorophores" *Proc. Natl. Acad. Sci. USA* (1988) 85:5610-5614.

Matthews et al., "Analytical strategies for the use of DNA probes" *Analytical Biochem.* (1988) 169:1-25.

Prober et al., "A system for rapid DNA sequencing with fluorescent chain-terminating dideoxynucleotides" *Science* (1987) 238:336-341.

Draper, "Attachment of reporter groups to specific, selected cytidine residues in RNA using a bisulfite-catalyzed transamination reaction" *Nucleic Acids Research* (1984) 12(2):989-1002.

Fourrey et al., "Preparation and phosphorylation reactivity at N-nonacylated nucleoside phosphoramidites" *Chemical Abstracts* (1986) 104:130215a.

- Tanaka et al., "Synthesis and properties of phosphoramidite derivatives of modified nucleosides" *Chemical Abstracts* (1987) 106:33420x.
- Chu et al., "Derivatization of unprotected polynucleotides" *Nucleic Acids Research* (1983) 11:6513-6529.
- Akusjärvi et al., "Nucleotide sequence at the junction between the coding region of the adenovirus 2 hexon messenger RNA and its leader sequence" *Proc. Natl. Acad. Sci. USA* (1978) 75(12):5822-5826.
- Takanami et al., "DNA Sequence Analysis Manual" Kodansya Co. Ltd., Nov. 1983, pp. 49-54.
- Takanami et al., "DNA Sequence Analysis Manual" Kodansya Co. Ltd., Nov. 1983, pp. 49-54. (English Translation).
- U.S. District Court for the Western District of Wisconsin, Civil Docket for Case No. 01-C-0244-C.
- Corrected Brief in Support of Promega's Motion for Summary Judgment of Invalidity of U.S. Patent No. 6,200,748 Under 35 U.S.C. § 112 (dated Aug. 28, 2002).
- Applera's Opposition to Promega's Motion for Summary Judgment of Invalidity of U.S. Patent No. 6,200,748 Under 35 U.S.C. § 112 (dated Sep. 13, 2002).
- Reply Brief in Support of Promega's Motion for Summary Judgment of Invalidity of U.S. Patent No. 6,200,748 Under 35 U.S.C. § 112 (dated Sep. 30, 2002).
- Corrected Brief in Support of Promega's Motion for Summary Judgment of Invalidity of U.S. Patent No. 6,200,748 Under 35 U.S.C. §§ 102 and 103 (dated Aug. 28, 2002).
- Applera Corporation's Opposition to Promega's Motion for Summary Judgment of Invalidity of U.S. Patent No. 6,200,748 Under 35 U.S.C. §§ 102 and 103 (dated Sep. 13, 2002).
- Reply Brief in Support of Promega's Motion for Summary Judgment of Invalidity of U.S. Patent No. 6,200,748 Under 35 U.S.C. §§ 102 and 103 (dated Sep. 30, 2002).
- Opinion and Order from the United States District Court for the Western District of Wisconsin (Markman Order) (entered Jan. 2, 2002).
- "Declaration—Bd.R. 203(b)", mailed on Nov. 8, 2006 (7 pages) in Interference No. 105,496.
- List of documents filed by the parties and the Board of Patent Appeals and Interferences in Interference No. 105,496.
- Complaint filed by plaintiff MJ Research Inc.; Jury Trial Demanded, for Civil Action No. 1:00CV02262 (CKK), filed Sep. 21, 2000 (74 pages).
- First Amended Complaint by plaintiff MJ Research Inc.; Jury Trial Demanded, for Civil Action No. 1:00CV02262 (CKK), filed Aug. 30, 2001 (104 pages).
- Second Amended Complaint by plaintiff MJ Research Inc.; Jury Trial Demanded, for Civil Action No. 1:00CV02262(CKK), filed Jun. 17, 2002 (82 pages).
- Memorandum Opinion (Jul. 3, 2003) by Judge Colleen Kollar-Kotelly, for Civil Action No. 1:00CV02262(CKK), Jul. 3, 2003 (20 pages).
- Order (Jul. 3, 2003) by Judge Colleen Kollar-Kotelly, for Civil Action No. 1-00-2262(CKK), Jul. 3, 2003 (3 pages).
- MJ Research Inc.'s Motion to Consolidate Pursuant to Fed.R.Civ.P. 42(a); Declaration of Valerie W. Ho and Exhibits in Support Thereof, for Case No. CV-03-05429, Aug. 15, 2003 (63 pages).
- Defendants' Opposition to MJ Research, Inc.'s Motion to Consolidate Pursuant to Fed.R.Civ.P. 42(a), for Case No. CV-03-05429 MRP (Ex), Aug. 25, 2003 (9 pages).
- Declaration of Anastasia M Smith in Support of Defendant's Opposition to MJ Research Inc.'s Motion to Consolidate Pursuant to Fed.R.Civ.P. 42(a), for Case No. CV-03-05429 MRP (Ex), Aug. 25, 2003 (71 pages).
- Third Amended Complaint by plaintiff MJ Research Inc.; Jury Trial Demanded, for Case No. CV-03-05429 MRP (Ex), Aug. 15, 2003 (64 pages).
- Notice of Motion and Memorandum in Support of Motion of Defendant California Institute of Technology's Motion to Dismiss Third Amended Complaint Pursuant to Fed.R.Civ.P. (12)(b)(1), for Case No. CV-03-05429 MRP (Ex), Aug. 29, 2003 (29 pages).
- Declaration of Anastasia M. Smith in Support of Defendant California Institute of Technology's Motion to Dismiss Third Amended Complaint Pursuant to Fed.R.Civ.P. 12(b)(1), for Case No. CV-03-05429 MRP (Ex), Aug. 29, 2003 (144 pages).
- Defendants Applera Corporation, Applied Biosystems Group, and Celera Genomics Group's Notice of Motion and Memorandum in Support of Motion to Dismiss Third Amended Complaint Pursuant to Fed.R.Civ.P. 12(b)(6), for Case No. CV-03-05429 MRP (ex), Aug. 29, 2003 (21 pages).
- Declaration of Matthew R. Hulse in Support of Defendants Applera Corporation, Applied Biosystems Group, and Celera Genomics Group's Motion to Dismiss, for Case No. CV-03-05429 MRP (ex), Aug. 29, 2003 (171 pages).
- Plaintiff MJ Research, Inc.'s Opposition to Defendants Applera Corporation, Applied Biosystems Group, and Celera Genomics Group's Motion to Dismiss Third Amended Complaint, for Case No. CV-03-05429 MRP (ex), Sep. 23, 2003 (19 pages).
- Paper 120, "Decision, Bd.R. 125 on motions," for Patent Interference No. 105,496, United States Patent and Trademark Office Board of Patent Appeals and Interferences, entered Sep. 22, 2010 (29 pages).
- Paper 121, "Redeclaration—Bd.R. 203" by Richard Torczon, Administrative Patent Judge, for Patent Interference No. 105,496, United States Patent and Trademark Office Board of Patent Appeals and Interferences, entered Sep. 22, 2010 (4 pages).
- Paper 122, "Judgment, Bd.R. 127," for Patent Interference No. 105,496, United States Patent and Trademark Office Board of Patent Appeals and Interferences, entered Sep. 22, 2010 (2 pages).
- California Institute of Technology Clean Copy of Claims, for Patent Interference No. 105,496 (RT), dated Nov. 21, 2006 (10 pages).
- Enzo Clean Copy of Claims, for Patent Interference No. 105,496 (RT), dated Nov. 21, 2006 (120 pages).
- California Institute of Technology Annotated Copy of Claims, for Patent Interference No. 105,496 (RT), dated Dec. 6, 2006 (10 pages).
- California Institute of Technology List of Proposed Motions, for Patent Interference No. 105,496 (RT), dated Feb. 28, 2007 (5 pages).
- Enzo List of Motions, for Patent Interference No. 105,496 (RT), dated Feb. 28, 2007 (4 pages).
- Enzo Corrected Substantive Motion (1) (Judgment Under Bd.R. 121(a)(1)(i) to redefine the scope of the contested case by changing the correspondence of claims to the count.), for Patent Interference No. 105,496 (RT), dated Mar. 23, 2007 (54 pages).
- Enzo Substantive Motion (2) (Judgment Under Bd.R. 121(a)(1)(i) to redefine the scope of the contested case by reducing without prejudice the number of claims in Enzo's involved application, for Patent Interference No. 105,496 (RT), dated Mar. 23, 2007 (11 pages).
- California Institute of Technology Priority Statement, for Patent Interference No. 105,496 (RT), dated May 3, 2007 (7 pages).
- California Institute of Technology Motion 3 (Substantive Motion to Deny Accorded Benefit for Lack of Required Continuity), for Patent Interference No. 105,496 (RT), dated May 3, 2007 (30 pages).
- California Institute of Technology Motion 4 (for Judgment Based on Lack of Written Description), for Patent Interference No. 105,496 (RT), dated May 3, 2007 (44 pages).
- California Institute of Technology Motion 5 (to Deny Enzo Benefit of the '440 and '352 Applications), for Patent Interference No. 105,496 (RT), dated May 3, 2007 (44 pages).
- California Institute of Technology Motion 6 (Motion for Judgment Under 35 U.S.C. § 102), for Patent Interference No. 105,496 (RT), dated May 3, 2007 (58 pages).
- California Institute of Technology Motion 7 (for Judgment Under 35 U.S.C. § 135(b)(1)), for Patent Interference No. 105,496 (RT), dated May 3, 2007 (44 pages).
- California Institute of Technology Motion 8 (Motion for Unpatentability on ground of Prosecution Laches), for Patent Interference No. 105,496 (RT), dated May 3, 2007 (33 pages).
- Enzo Substantive Motion 3, for Patent Interference No. 105,496 (RT), dated May 3, 2007 (15 pages).
- Enzo Substantive Motion 4, for Patent Interference No. 105,496 (RT), dated May 3, 2007 (40 pages).
- Caltech Objections to Evidence Served on May 3, 2007, for Patent Interference No. 105,496 (RT), dated May 9, 2007 (3 pages).
- Enzo's Objections to California Institute of Technology's Evidence Served with California Institute of Technology's Motion No. 8, for Patent Interference No. 105,496 (RT), dated May 10, 2007 (4 pages).

- California Institute of Technology Motion 9 (Response Motion for Benefit), for Patent Interference No. 105,496 (RT), dated May 22, 2007 (33 pages).
- California Institute of Technology Motion 10 (Contingent Responsive Motion To Review the '232 Application), for Patent Interference No. 105,496 (RT), dated May 22, 2007 (30 pages).
- Caltech Submission of Deposition Transcript of Dr. Gibbs, for Patent Interference No. 105,496 (RT), dated Jun. 13, 2007 (3 pages).
- California Institute of Technology Opposition 3, for Patent Interference No. 105,496 (RT), dated Jul. 18, 2007 (23 pages).
- California Institute of Technology Opposition 4, for Patent Interference No. 105,496 (RT), dated Jul. 18, 2007 (54 pages).
- Enzo Corrected Opposition 3, for Patent Interference No. 105,496 (RT), dated Jul. 18, 2007 (45 pages).
- Enzo Opposition 4, for Patent Interference No. 105,496 (RT), dated Jul. 18, 2007 (51 pages).
- Enzo Opposition 5, for Patent Interference No. 105,496 (RT), dated Jul. 18, 2007 (56 pages).
- Enzo Opposition 6, for Patent Interference No. 105,496 (RT), dated Jul. 18, 2007 (57 pages).
- Enzo Opposition 7, for Patent Interference No. 105,496 (RT), dated Jul. 18, 2007 (53 pages).
- Enzo Opposition 8, for Patent Interference No. 105,496 (RT), dated Jul. 18, 2007 (51 pages).
- Enzo Opposition 9, for Patent Interference No. 105,496 (RT), dated Jul. 18, 2007 (42 pages).
- Enzo Opposition 10, for Patent Interference No. 105,496 (RT), dated Jul. 18, 2007 (25 pages).
- Enzo's Objections to California Institute of Technology's Evidence Served with California Institute of Technology's Opposition No. 4, for Patent Interference No. 105,496 (RT), dated Jul. 24, 2007 (2 pages).
- California Institute of Technology Objections to Enzo's Evidence Served Jul. 18, 2007, for Patent Interference No. 105,496 (RT), dated Jul. 25, 2007 (2 pages).
- California Institute of Technology Reply 3, for Patent Interference No. 105,496 (RT), dated Sep. 13, 2007 (36 pages).
- California Institute of Technology Reply 4, for Patent Interference No. 105,496 (RT), dated Sep. 13, 2007 (61 pages).
- California Institute of Technology Reply 5, for Patent Interference No. 105,496 (RT), dated Sep. 13, 2007 (77 pages).
- California Institute of Technology Reply 6, for Patent Interference No. 105,496 (RT), dated Sep. 13, 2007 (64 pages).
- California Institute of Technology Reply 7 (For Judgment Under 35 U.S.C. § 135(b)(1)), for Patent Interference No. 105,496 (RT), dated Sep. 13, 2007 (48 pages).
- California Institute of Technology Reply 8, for Patent Interference No. 105,496 (RT), dated Sep. 13, 2007 (51 pages).
- California Institute of Technology Reply 9 (Response Motion for Benefit), for Patent Interference No. 105,496 (RT), dated Sep. 13, 2007 (39 pages).
- California Institute of Technology Reply 10, for Patent Interference No. 105,496 (RT), dated Sep. 13, 2007 (19 pages).
- Enzo Reply 3, for Patent Interference No. 105,496 (RT), dated Sep. 13, 2007 (27 pages).
- Enzo Reply 4, for Patent Interference No. 105,496 (RT), dated Sep. 13, 2007 (57 pages).
- California Institute of Technology Motion 12 (Miscellaneous Motion to Exclude Enzo Exhibits 1024 and 1056), for Patent Interference No. 105,496 (RT), dated Oct. 4, 2007 (23 pages).
- California Institute of Technology Listing of Exhibits, for Patent Interference No. 105,496 (RT), dated Oct. 4, 2007 (18 pages).
- Enzo Motion 5 (to Exclude), for Patent Interference No. 105,496 (RT), dated Oct. 4, 2007 (13 pages).
- Decision Bd.R. 125 on Motion, Paper 101, for Patent Interference No. 105,496 (RT), dated Oct. 19, 2007 (6 pages).
- Enzo Opposition 12, for Patent Interference No. 105,496 (RT), dated Oct. 25, 2007 (25 pages).
- California Institute of Technology Reply 12, for Patent Interference No. 105,496 (RT), dated Nov. 7, 2007 (30 pages).
- Oral Hearing Held: Thursday, Nov. 29, 2007, Paper 113, for Patent Interference No. 105,496 (RT), (79 pages).
- Order addressing cross examination misconduct, Paper 117, for Patent Interference No. 105,496 (RT), dated Mar. 30, 2010 (32 pages).
- Request for Rehearing Under 37 C.F.R. § 41.125(c), for Patent Interference No. 105,496 (RT), dated Apr. 12, 2010 (12 pages).
- Enzo Updated List of Exhibits, for Patent Interference No. 105,496 (RT), dated Apr. 12, 2010 (11 pages).
- Updated List of Documents Filed by the Parties and the Board of Patent Appeal and Interferences in Interference No. 105,496, May 14, 2010 (3 pages).
- Smith et al., "Fluorescence detection in automated DNA sequence analysis," *Nature*, 321: 674-679 (1986).
- Heiner et al., Chapter 8: Automated DNA sequencing, from *Nucleic acids sequencing: a practical approach*, Eds. Howe and Ward, IRL Press at Oxford University Press, New York, NY, pp. 221-235 (1989).
- Takeda et al., "Synthesis of oligonucleotides containing the hypermodified base,  $\alpha$ -putrescinylythymine," *Nucleic Acids Res. Symposium Series*, 12: 75-78 (1983).
- Hindley, *Laboratory Techniques in Biochemistry and Molecular Biology: DNA Sequencing* (1986).
- Wildeman et al., "Structural Studies of 5 S Ribosomal RNAs from a Thermophilic Fungus, *Thermomyces lanuginosus*," *J. Biol. Chem.*, 257(19):11395-11404 (1982).
- Som et al., "Inhibition of Transcription in Vitro by Binding of DNA(Cytosine-5)- Methylases to DNA Templates Containing Cytosine Analogs," *J. Biol. Chem.*, 269(42):25986-25991 (1994).
- Laub et al., "Expression of the Human Insulin Gene in an Alternate Mammalian Cell and in Cell Extracts," *J. Biol. Chem.*, 258(10):6037-6042 (1983).
- Torri et al. "A  $\beta$ -Like DNA Polymerase from the Mitochondrion of the Trypanosomatid *Crithidia fasciculata*," *J. Biol. Chem.*, 269(11):8165-8171 (1994).
- Dubin et al., "Sequence Analysis and Precise Mapping of the 3' Ends of HeLa Cell Mitochondrial Ribosomal RNAs," *J. Mol. Biol.*, 157:1-19 (1982).
- Carlson et al., "The Secreted Form of Invertase in *Saccharomyces cerevisiae* Is Synthesized from mRNA Encoding a Signal Sequence," *Mol. Cell. Biol.*, 3(3):439-447 (1983).
- Laub et al., "Expression of the Human Insulin Gene and cDNA in a Heterologous Mammalian System," *J. Biol. Chem.*, 258(10):6043-6050 (1983).
- Thiem et al., "Identification, Sequence, and Transcriptional Mapping of the Major Capsid Protein Gene of the Baculovirus *Autographa californica* Nuclear Polyhedrosis Virus," *J. Virol.*, 63(5):2008-2018 (1989).
- Dickson et al., "Nuclease S1 Mapping of a Homozygous Mutation in the Carboxylpropeptide-coding Region of the pro $\alpha$ 2(I) Collagen Gene in a Patient with Osteogenesis Imperfecta," *Proc. Natl. Acad. Sci., USA*, 81:4524-4528 (1984).
- Periasamy et al., "Characterization of a Developmentally Regulated Perinatal Myosin Heavy-chain Gene Expressed in Skeletal Muscle," *J. Biol. Chem.*, 259(21):13573-13578 (1984).
- Guilfoyle et al., "Control region for adenovirus VA RNA transcription," *Proc. Natl. Acad. Sci., USA*, 78(6): 3378-3882 (1981).
- Smith et al., "Fluorescence detection in automated DNA sequence analysis," *Nature*, 321:674-679 (Jun. 12, 1986).
- Brennand et al., "Cloned cDNA sequences of the hypoxanthine/guanine phosphoribosyltransferase gene from a mouse neuroblastoma cell line found to have amplified genomic sequences," *Proc. Natl. Acad. Sci. USA* 79: 1950-1954 (1982).
- Pingoud et al., "Fluoresceinylythiocarbamyl-tRNA<sup>Tyr</sup>: a Useful Derivative of tRNA<sup>Tyr</sup> (*E. coli*) for Physicochemical Studies," *Nucleic Acids Research*, 4(2): 327-38 (1977).
- Kasai et al., "Specific fluorescent labeling of 7-(aminomethyl)-7-deazaguanosine located in the anticodon of tRNA<sup>Tyr</sup> isolated from *E. coli* mutant," *Nucleic Acids Research*, 7(1): 231-38 (1979).
- Saito et al., "A simple synthesis of fluorescent uridines by photochemical method," *Tetrahedron Letters*, 21: 2813-2816 (1980).
- Cantor et al., "Biophysical Chemistry Part II: Techniques for the Study of Biological Structure and Function," (San Francisco, W. H. Freeman): 439-448 (1980).

Tsuchiya, "Development of DNA Fluorescent Labeling and Real-Time Fluorescent Detection Gel Electrophoresis," Abstract of Master's Thesis Presentations, Saitama University.

Hushimi et al. "Automation and Testing of DNA Base Sequence Determination Methods," in *Research Results re: Development of Physical Means of Measurement and Software for Informed Macromolecular Analysis*, 2-10 (1984).

Biochemistry, L. Stryer, 2nd ed., W. H. Freeman and Co., 1981, p. 511-513.

Xu et al., "Human Epidermal Growth Factor Receptor cDNA is Homologous to a Variety of RNAs Overproduced in A431 Carcinoma Cells," *Nature*, vol. 309, pp. 806-810 (Jun. 1984).

Rabbitts et al., "The Variability, Arrangement, and Rearrangement of Immunoglobulin Genes," *Canadian Journal of Biochemistry*, vol. 58, No. 3, pp. 176-187 (Mar. 1980).

Barrell et al., "Biological Chemistry of Organelle Formation," *Hoppe-Seyler's Z Physiol. Chem.*, Bd. 361, S. 493-501 (Apr. 1980).

De Bruijn et al., "A Mammalian Mitochondrial Serine Transfer RNA Lacking the "Dihydrouridine" Loop and Stem," *Nucleic Acids Research*, vol. 8, No. 22, pp. 5213-5222 (1980).

Ma et al., "Nucleotide Sequences of Two Regions of the Human Genome Containing tRNA<sup>Asn</sup> Genes," *Gene*, 28, pp. 257-262 (1984).

Patent Interference No. 105,496 *California Institute of Technology v. Enzo Life Sciences, Inc.*, Paper 129, Entered Mar. 7, 2010, pp. 1-7.

Deng, G, et al, An improved procedure for utilizing terminal transferase to add homopolymers to the 3' termini of DNA, *Nuc Acids Res*, vol. 9(16), pp. 4173-4188, 1981.

Relator MJ Research, Inc.'s Memorandum in Opposition to Defendants' Motion to Dismiss Third Amended Complaint Pursuant to Fed.R.Civ.P. 12(b)(1), for Case No. CV-03-05429, Sep. 23, 2003 (30 pages).

Declaration of George Corey in Support of Relator MJ Research, Inc.'s Opposition to Defendant California Institute of Technology's Motion to Dismiss Third Amended Complaint Pursuant to Fed.R.Civ.P. 12(b)(6), for Case No. CV-03-05429, Sep. 23, 2003 (97 pages).

Declaration of Dr. Michael J. Finney in Support of Relator MJ Research, Inc.'s Opposition to Defendant California Institute of Technology's Motion to Dismiss Third Amended Complaint Pursuant to Fed.R.Civ.P. 12(b)(6), for Case No. CV-03-05429, Sep. 23, 2003 (62 pages).

Plaintiff MJ Research, Inc.'s Reply Memorandum in Support of Motion to Consolidate Pursuant to Fed.R.Civ.P. 42(a), for Case No. CV-03-05429 MRP (ex), Sep. 30, 2003 (10 pages).

Declaration of Kevin E Stern in Support of Relator MJ Research, Inc.'s Motion to Consolidate Pursuant to Fed.R.Civ.P. 42(a), for Case No. CV-03-05429 MRP (ex), Sep. 30, 2003 (60 pages).

Reply Memorandum in Support of Applera Corporation's Motion to Dismiss Third Amended Complaint Pursuant to Fed.R.Civ.P. (12)(b)(6), for Case No. CV-03-05429 MRP (ex), Sep. 30, 2003 (18 pages).

Reply Memorandum in Support of Defendant California Institute of Technology's Motion to Dismiss Third Amended Complaint Pursuant to Fed.R.Civ.P. 12(b)(1), for Case No. CV-03-05429 MRP (ex), Sep. 30, 2003 (15 pages).

United States' Statement of Interest Under 28 U.S.C. § 517 and Application to File *Amicus Curiae* Brief in Opposition to Motion to Dismiss Filed by Defendant California Institute of Technology, for Case No. CV-03-05429 MRP (ex), Sep. 30, 2003 (6 pages).

United States' Statement of Interest Under 28 U.S.C. § 517 and *Amicus Curiae* Brief in Opposition to Motion to Dismiss Filed by Defendant California Institute of Technology, for Case No. CV-03-05429 MRP (ex), Sep. 30, 2003 (16 pages).

Civil Minutes—General for Oct. 7, 2003, Court Hearing, for CV-03-1140 MRP and CV-03-5429 MRP, dated Oct. 8, 2003 (1 page).

Civil Minutes—General dated/filed Oct. 7, 2003, for Case No. CV-03-05429 MRP(Ex), Oct. 7, 2003 (1 page).

Memorandum of Decision and Order Re Caltech's Motion to Dismiss Third Amended Complaint Pursuant to Fed. R. Civ. P. 12(b)(1) and Applera et. al.'s Motion to Dismiss Third Amended Complaint Pursuant Fed. R. Civ. P. 12(b)(6) and MJ's Motion to Consolidate with *Huang v. California Institute of Technology et al.*, (CV-03-1140 MRP) , for Case No. CV-03-05429 MRP(Ex), Oct. 16, 2003 (18 pages).

Notice of Appeal filed by MJ Research, Inc., for Case No. CV-03-05429 MRP(Ex), Nov. 6, 2003 (22 pages).

Appellant's Brief and Appellant's Record Excerpts, filed by United States of America (ex. rel.), Plaintiff, and MJ Research, Inc., Relator-Appellant, in Appeal No. 03-57229 in the United States Court of Appeals for the Ninth Circuit, Feb. 23, 2004 (167 pages).

Appellee Applera Corporation's Answering Brief and Appellee Applera Corporation's Supplemental Excerpts of Record , filed in Appeal No. 03-57229 in the United States Court of Appeals for the Ninth Circuit, Apr. 7, 2004 (155 pages).

Answering Brief of Appellee California Institute of Technology and Appellee California Institute of Technology's Supplemental Excerpts of Record , filed in Appeal No. 03-57229 in the United States Court of Appeals for the Ninth Circuit, Apr. 7, 2004 (240 pages).

Appellant's Reply Brief, filed by United States of America (ex. rel.), Plaintiff, and MJ Research, Inc., Relator-Appellant, in Appeal No. 03-57229 in the United States Court of Appeals for the Ninth Circuit, May 10, 2004 (31 pages).

Memorandum (affirmed) from the United States Court of Appeals for the Ninth Circuit for Appeal No. 03-57229, filed Nov. 21, 2005 (4 pages).

Complaint for (1) Substitution of Patent Inventor (§ 35 U.S.C., § 256); (2) Breach of Contract; (3) Fraud; (4) Conversion; and (5) Unjust Enrichment, Jury Trial Demanded, for Case No. 03-1140 (Ex), Feb. 18, 2003 (102 pages).

Answer and Counterclaim of Defendant California Institute of Technology to Plaintiff Henry Huang's Complaint (1) Substitution of Patent Inventor (35 U.S.C., § 256); (2) Breach of Contract; (3) Fraud; (4) Conversion; and (5) Unjust Enrichment, Jury Trial Demanded, for Case No. 03-1140 PA (Ex), Mar. 14, 2003 (13 pages).

Reply of Dr. Henry Huang to Counterclaims of Defendant CalTech, for Case No. 03-1140 PA (Ex), Apr. 7, 2003 (7 pages).

Reply of Dr. Henry Huang to Counterclaims of Defendants Applera Corporation and Its Applied Biosystems Group, for Case No. 03-1140 PA (Ex), Apr. 10, 2003 (8 pages).

Notice of Motion and Memorandum in Support of Motion to Dismiss Complaints Against Defendants John D. Lytle, William J. Mordan, and John A. Bridgham, for Case No. CV03-1140 PA (Ex), May 6, 2003 (13 pages).

Answer of Defendant Michael W. Hunkapiller to Plaintiff Henry Huang's Complaint for (1) Substitution of Patent Inventor (35 U.S.C., § 256); (2) Breach of Contract; (3) Fraud; (4) Conversion; and (5) Unjust Enrichment, for Case No. 03-1140 PA (Ex), May 5, 2003 (16 pages).

Answer of Defendant Charles R. Connell to Plaintiff Henry Huang's Complaint for (1) Substitution of Patent Inventor (35 U.S.C., § 256); (2) Breach of Contract; (3) Fraud; (4) Conversion; and (5) Unjust Enrichment, for Case No. 03-1140 PA (Ex), May 5, 2003 (15 pages).

Answer of Defendant Timothy J. Hunkapiller to Plaintiff Henry Huang's Complaint for (1) Substitution of Patent Inventor (35 U.S.C., § 256); (2) Breach of Contract; (3) Fraud; (4) Conversion; and (5) Unjust Enrichment, for Case No. 03-1140 PA (Ex), May 5, 2003 (15 pages).

Answer of Defendant Lloyd M. Smith to Plaintiff Henry Huang's Complaint for (1) Substitution of Patent Inventor (35 U.S.C., § 256); (2) Breach of Contract; (3) Fraud; (4) Conversion; and (5) Unjust Enrichment, for Case No. 03-1140 PA (Ex), May 5, 2003 (15 pages).

Answer and Counterclaim of Defendant Leroy E. Hood to Plaintiff Henry Huang's Complaint (1) Substitution of Patent Inventor (35 U.S.C. § 256); (2) Breach of Contract; (3) Fraud; (4) Conversion; and (5) Unjust Enrichment, Jury Trial Demanded, for Case No. CV03-1140 PA (Ex), May 12, 2003 (17 pages).

Notice of Dismissal without Prejudice as to Defendants John D. Lytle, William J. Mordan, and John A. Bridgham, for Case No. CV03-1140 PA (Ex), May 19, 2003 (6 pages).

Plaintiffs' Response to Defendants John D. Lytle, William J. Mordan, and John A. Bridgham's Motion to Dismiss Complaint, for Case No. Mar. 1140 PA (Ex), May 19, 2003 (16 pages).

Reply Memorandum in Support of Motion to Dismiss Complaint Against Defendants John D. Lytle, William J. Mordan, and John A. Bridgham, for Case No. CV03-1140 PA (Ex), May 23, 2003 (11 pages).

Plaintiff's Answer to Defendant Leroy E. Hood's Counterclaims, for Case No. 03-1140 PA (Ex), Jun. 4, 2003 (7 pages).

Civil Minutes—General, for Case No. CV 03-01140 PA (Ex), dated Jun. 12, 2003 (4 pages).

Notice of Pendency of Other Actions or Proceedings Pursuant to L.R. 83-1.4, for Case No. CV03-1140 PA (Ex), Jun. 4, 2003 (6 pages).

Amended Complaint, Jury Trial Demanded, for Case No. 03-1140 PA (Ex), Jun. 25, 2003 (104 pages).

Defendants' Notice of Motion and Memorandum in Support of Motion to Dismiss Counts III, IV, and VI of the Amended Complaint, Jul. 14, 2003 (18 pages).

Plaintiff's Preliminary Invention Contentions, for Case No. 03-1140PA(Ex), Jul. 21, 2003 (28 pages).

Plaintiff's Memorandum of Points and Authorities in Opposition to Defendants' Motion to Dismiss, for Case No. 03-1140PA(ex), Jul. 28, 2003 (10 pages).

Civil Minutes—General, for Case No. CV 03-01140 PA (Ex), dated Aug. 5, 2003 (1 page).

Declaration of Michelle J. Kane in Support of Reply to Defendants' Motion to Dismiss, for Case No. CV03-1140 PA (Ex), Aug. 4, 2003 (15 pages).

Defendants' Reply in Support of Their Motion to Dismiss Counts III, IV, and VI of the Amended Complaint, for Case No. 03-1140 PA (Ex), Aug. 4, 2003 (10 pages).

Civil Minutes—General, for Case No. CV 03-01140 PA (Ex), dated Aug. 8, 2003 (2 pages).

Joint Written Technology Tutorial, for Case No. CV-03-1140 MRP (Ex), Aug. 19, 2003 (41 pages).

Joint Report Regarding the Meaning of Claims of the Patents-In-Suit, for Case No. CV03-1140 PA (Ex), Aug. 18, 2003 (4 pages).

Answer of Defendant Charles R. Connell to Plaintiff Henry Huang's Amended Complaint, for Case No. 03-1140 MRP (Ex), Aug. 25, 2003 (14 pages).

Answer of Defendant Michael W. Hunkapiller to Plaintiff Henry Huang's Amended Complaint, for Case No. 03-1140 MRP (Ex), Aug. 25, 2003 (14 pages).

Answer of Defendant Timothy J. Hunkapiller to Plaintiff Henry Huang's Amended Complaint, for Case No. 03-1140 MRP (Ex), Aug. 25, 2003 (14 pages).

Answer of Defendant Lloyd M. Smith to Plaintiff Henry Huang's Amended Complaint, for Case No. 03-1140 MRP (Ex), Aug. 25, 2003 (14 pages).

Answer and Counterclaim of Defendant California Institute of Technology to Plaintiff Henry Huang's Amended Complaint, Jury Trial Demanded, for Case No. 03-1140 MRP (Ex), Aug. 25, 2003 (17 pages).

Answer and Counterclaims of Leroy E. Hood to Henry Huang's Amended Complaint, for Case No. CV03-1140 MRP (Ex), Jury Trial Demanded, Aug. 25, 2003 (19 pages).

Answer of Defendants Applera Corporation and Its Applied Biosystems Group to Plaintiff Henry Huang's Amended Complaint and Counterclaims, Jury Trial Demanded, for Case No. 03-1140 MRP (Ex), Aug. 25, 2003 (16 pages).

Defendants' Notice of Motion and Memorandum in Support of Motion to Enforce Court-ordered Disclosure of Plaintiff's Invention Contentions, for Case No. CV03-1140 MRP (Ex), Aug. 26, 2003 (14 pages).

Declaration of Matthew R. Hulse in Support of Defendants' Motion to Enforce Court-ordered Disclosure of Plaintiff's Invention Contentions, Aug. 26, 2003 (100 pages).

Answer of Defendant John D. Lytle to Plaintiff Henry Huang's Amended Complaint, Aug. 25, 2003 (14 pages).

Answer of Defendant John A. Bridgham to Plaintiff Henry Huang's Amended Complaint, Aug. 25, 2003 (14 pages).

Answer of Defendant William J. Mordan to Plaintiff Henry Huang's Amended Complaint, Aug. 25, 2003 (14 pages).

Plaintiff's Answer to Defendant Leroy Hood's Counterclaims, Sep. 17, 2003 (9 pages).

Plaintiff's Answer to Defendant California Institute of Technology's Counterclaims, for Case No. CV 03-1140 PA (ExO), Sep. 13, 2002 (6 pages).

Plaintiff's Answer to Defendant Applera Corporations' Counterclaims, for Case No. CV 03-11400 PA(Ex), Sep. 17, 2003 (6 pages).

Plaintiff's Opposition to Defendants' Motion to Enforce Court Ordered Disclosure of Plaintiff's Invention Contentions, for Case No. CV 03-1140 MRP (Ex), Sep. 23, 2003 (5 pages).

Defendants' Reply Memorandum in Support of Motion to Enforce Court-ordered Disclosure of Plaintiff's Invention Contentions, , for Case No. CV03-1140 MRP (Ex), Sep. 30, 2003 (7 pages).

Plaintiff's Notice of Motion and Motion for Leave to File Second Amended Complaint; Memorandum of Points and Authorities, Declaration of Bradley Morris, and Proposed Second Amended Complaint in Support Thereof, for Case No. CV 03-1140 MRP (Ex), Oct. 6, 2003 (79 pages).

Civil Minutes—General, for Case No. CV 03-01140 MRP (Ex), dated Oct. 7, 2003 (1 page).

Civil Minutes—General, for Case No. CV 03-05429 MRP (Ex), dated Oct. 7, 2003 (2 pages).

Plaintiff's Revised Invention Contentions, for Case No. 03-1140 MRP (Ex), Oct. 17, 2003 (15 pages).

Defendants' Opposition to Plaintiff's Motion for Leave to File a Second Amended Complaint, for Case No. CV03-1140 MRP (Ex), Oct. 20, 2003 (15 pages).

Declaration of Edward R. Reines in Support of Defendants' Opposition to Plaintiff's Motion for Leave to File a Second Amended Complaint, for Case No. CV03-1140 MRP (Ex), Oct. 20, 2003 (52 pages).

Plaintiff's Reply Memorandum in Support of Motion for Leave to file Second Amended Complaint, for Case No. CV 03-1140 MRP (Ex), Oct. 27, 2003 (14 pages).

Plaintiff's Trial Brief, for Case No. 03-1140 MRP (Ex), Nov. 3, 2003 (170 pages).

Notice of Defendants' Motion for Additional Time to Depose Dr. Huang, for Case No. CV03-1140 MRP (Ex), Nov. 10, 2003 (3 pages).

Declaration of Matthew R. Hulse in Support of Defendants' Motion for Additional Time to Depose Dr. Huang, for Case No. CV03-1140 MRP (Ex), Nov. 10, 2003 (193 pages).

Joint Stipulation for Defendants' Motion for Additional Time to Depose Dr. Huang, for Case No. CV03-1140 MRP (Ex), Nov. 10, 2003 (13 pages).

Declaration of Bradley C. Morris in Opposition to Defendants' Motion for Additional Time to Depose Dr. Huang, for Case No. 03-1140 MRP (Ex), Nov. 10, 2003 (25 pages).

Declaration of Edward R. Reines in Support of Defendants' Motion for Addition Time to Depose Dr. Huang, for Case No. CV03-1140 MRP (Ex), Nov. 10, 2003 (2 pages).

Defendants' Trial Brief, for Case No. 03-1140 MRP (Ex), Nov. 14, 2003 (56 pages).

Defendants' Ex Parte Application for Leave to File a Corrected Trial Brief, for Case No. 03-1140 MRP (Ex), Nov. 18, 2003 (5 pages).

Defendants' Corrected Trial Brief, for Case No. 03-1140 MRP (Ex), Nov. 18, 2003 (57 pages).

Defendants' Proposed Findings of Facts and Contentions of Law, for Case No. CV03-1140 MRP (Ex), Dec. 8, 2003 (36 pages).

Plaintiff's Proposed Pre-Trial Findings of Facts and Conclusions of Law, for Case No. CV 03-01140 MRP(Ex), Dec. 8, 2003 (27 pages).

Civil Minutes—General, for Case No. CV 03-1140 MRP (Ex), dated Dec. 17, 2003 (2 pages).

Civil Minutes—General, for Case No. CV 03-1140 MRP (Ex), dated Dec. 18, 2003 (2 pages).

Civil Minutes—General, for Case No. CV 03-1140 MRP (Ex), dated Dec. 19, 2003 (2 pages).

Civil Minutes—General, for Case No. CV 03-1140 MRP (Ex), dated Dec. 22, 2003 (2 pages).

Civil Minutes—General, for Case No. CV 03-1140 MRP (Ex), dated Dec. 23, 2003 (2 pages).

Defendants' Post Trial Proposed Findings of Fact and Contentions of Law, for Case No. CV03-1140 MRP (Ex), Jan. 9, 2004 (68 pages).

Plaintiff's Proposed Post Trial Findings of Fact and Conclusions of Law for Case No. CV 03-01140 MRP(Ex), Jan. 9, 2004 (34 pages).

Plaintiff's Second Amended Complaint and Jury Demand, for Case No. CV 03-01140 MRP(Ex), Feb. 2, 2004 (103 pages).

Memorandum of Decision, Findings of Fact, and Conclusions of Law Re Invention, for Case No. CV 03-1140 MRP, Feb. 17, 2004 (45 pages).

Answer and Counterclaims of Leroy E. Hood to Second Amended Complaint, for Case No. 03-1140 MRP (Ex0, Mar. 1, 2004 (23 pages).

Plaintiff's Answer to Defendant Leroy Hood's Counterclaims to Second Amended Complaint, for Case No. CV 03-1140 PA(Ex), May 6, 2004 (6 pages).

Defendants' Notice of Motion and Memorandum in Support of Motion to Dismiss Counts III-VIII of Plaintiff's Second Amended Complaint, for Case No. CV03-1140 MRP (Ex), May 5, 2004 (13 pages).

Plaintiff's Memorandum of Points and Authorities in Response to Defendants' Motion to Dismiss Counts III-VIII of Plaintiff's Second Amended Complaint, for Case No. CV 03-01140 MRP(Ex), May 24, 2004 (5 pages).

Stipulation and Order Re Dismissal of Second Amended Complaint, for Case No. CV03-1140 MRP (Ex), Jun. 4, 2004, Lodged Jun. 7, 2004 (6 pages).

Representation Statement, for Case No. CV 03-01140 MRP(Ex), Jul. 7, 2004 (4 pages).

United States District Court, Central District of California (Western Division—Los Angeles) Civil Docket for Case #: 2:03-cv-05429-MRP-E, printed May 21, 2010 (8 pages).

US District Court Civil Docket, U.S. District—District of Columbia (Washington DC), 1:00cv2262, *MJ Research Inc v. PE Corporation, et al.*, retrieved from the court on Thursday, May 21, 2010 (5 pages).

General Docket, United States Court of Appeals for the Ninth Circuit, Court of Appeals Docket #: 03-57229, printed May 21, 2010 (8 pages).

United States District Court, Central District of California (Western Division—Los Angeles) Civil Docket for Case #: 2:03-cv-01140-MRP-E, printed May 21, 2010 (23 pages).

Hindley in Proc. FEBS Symp: DNA—Recombination Interactions and Repair. Pergamon Press, New York, pp. 143-154, 1980.\*

Qu et al. Nucl. Acids Res. 11(17):5903-5920, Sep. 1983.\*

Husimi, Y., "DNA Sequencer" *Oyo Buturi* (1982) 51:(12):1400.

Gilbert, "DNA-sequenzierung und gen-struktur (Nobel-Vortrag)" *Angewandte Chemie* (1981) 93:1037-1046.

Kagakukai ed., "Fluorescence tagging" *Biochemistry Experiments Course 2, Nucleic Acid Chemistry III* (1977) pp. 299-317.

Douglass et al., "Methods and instrumentation for fluorescence quantitation of proteins and DNA's in electrophoresis gels at the 1 ng level" in *Electrophoresis '78*, N. Catsimopoulos, ed. (1978) pp. 155-165.

Tsuchiya, M. (1982). "Development of DNA Fluorescent Labeling and Real-Time Fluorescence Detection Gel Electrophoresis Methods," *Biophysics* 22:S170 (English translation attached).

\* cited by examiner





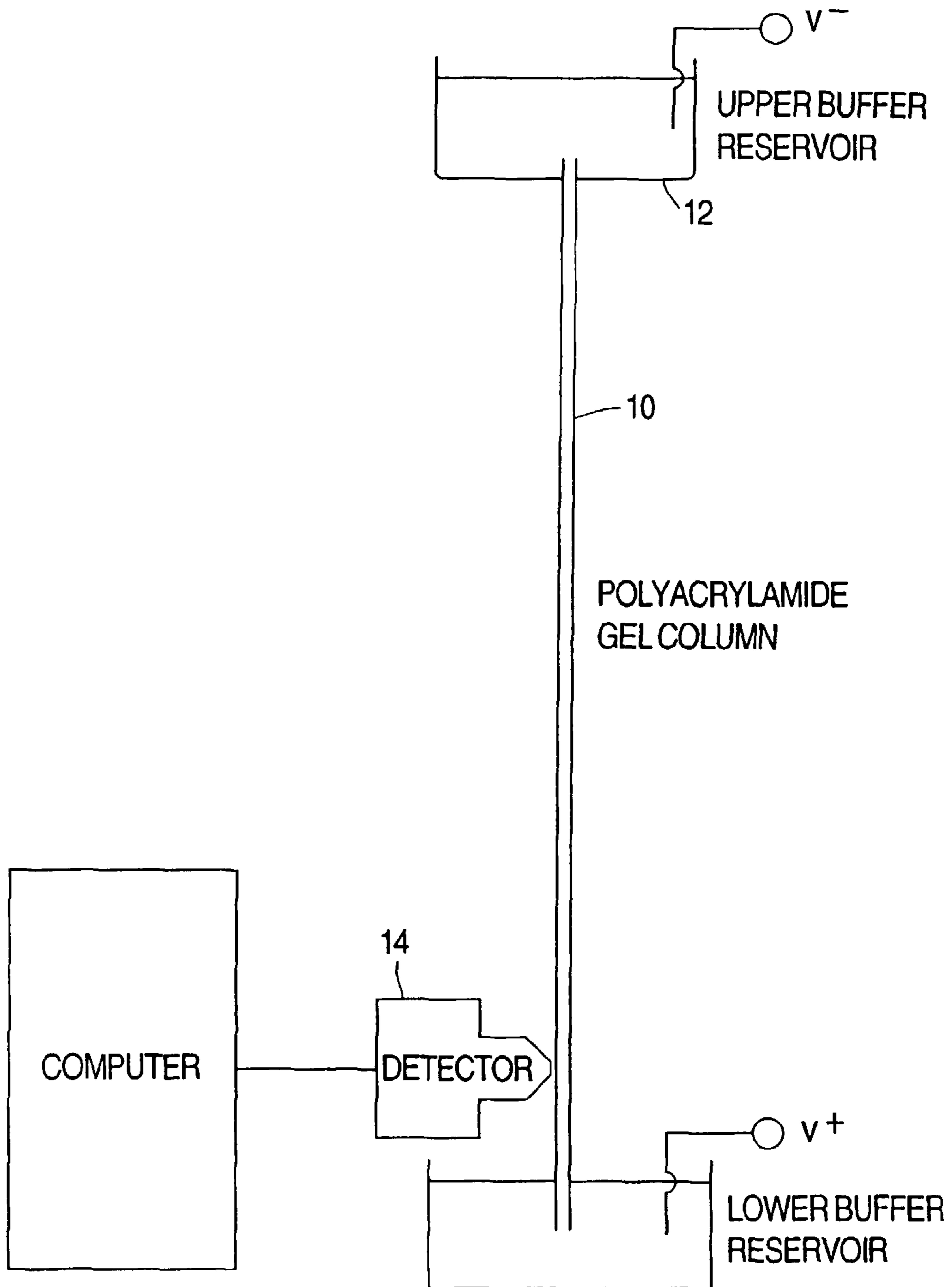
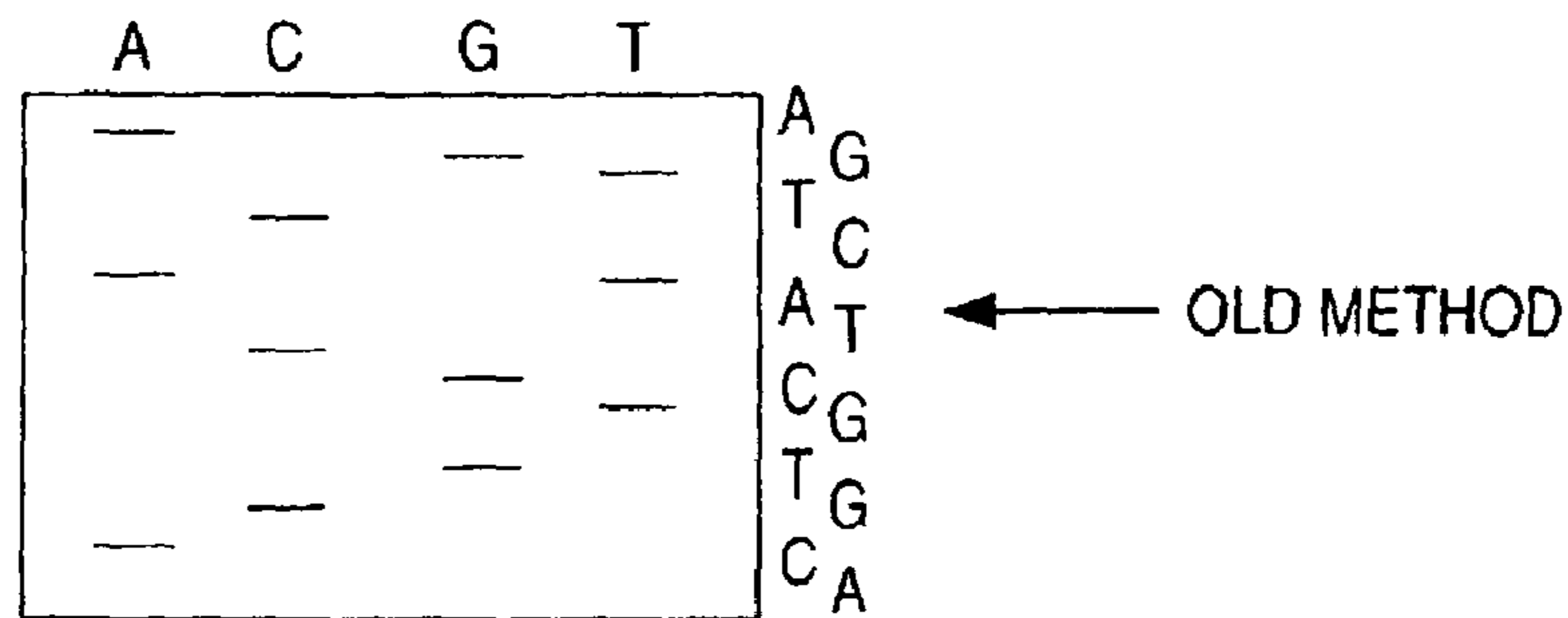
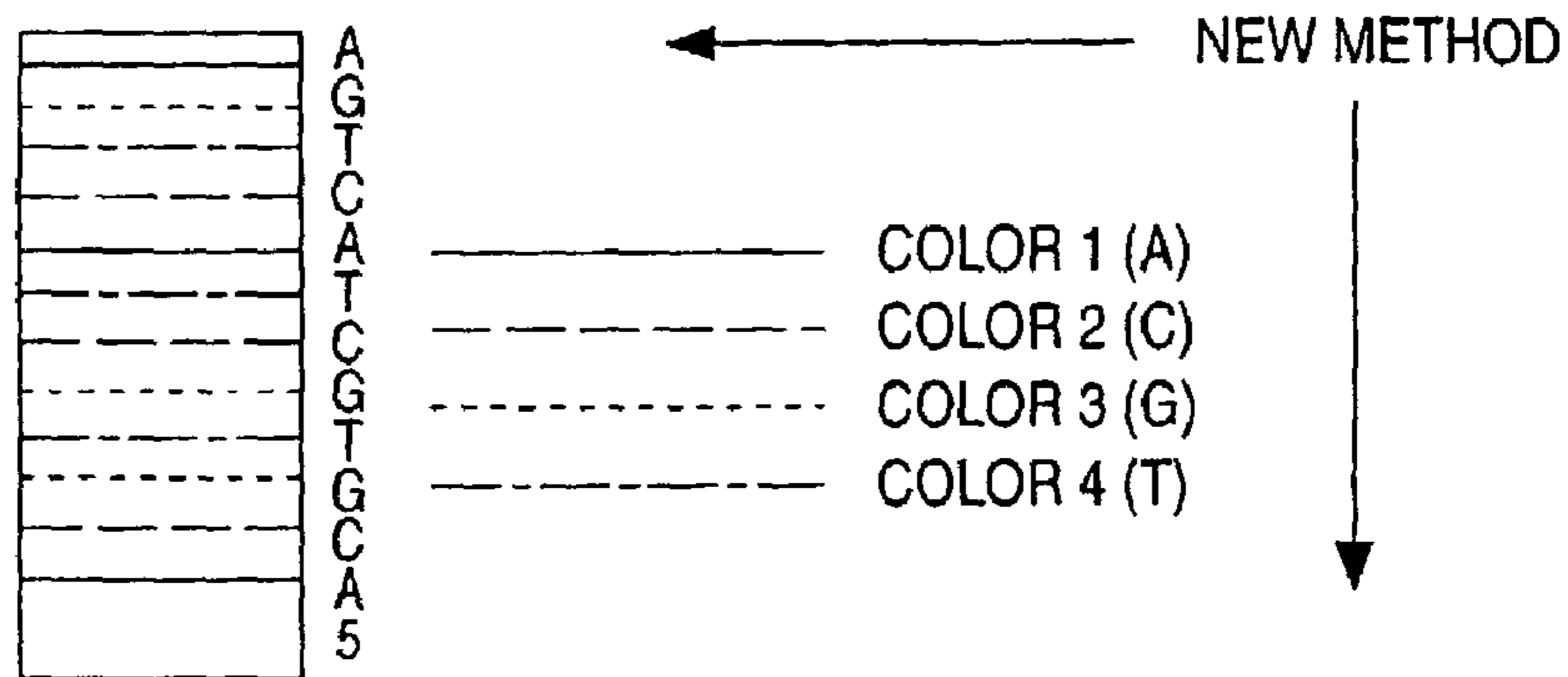

FIG. 2

- I) A HYPOTHETICAL DNA SEQUENCE  
5' ACGTGCTACTGA 3'
  
- II) IDEALIZED AUTORADIOGRAM OF POLYACRYLAMIDE SLAB GEL  
PRODUCED IN CHAIN TERMINATION SEQUENCING ACCORDING TO  
THE PRIOR ART



- III) IDEALIZED DIAGRAM OF COLORED DNA BANDS ON TUBE ACRYLAMIDE  
GEL, PRODUCED ACCORDING TO PRESENT INVENTION



- IV) IDEALIZED OUTPUT FROM DETECTION OF COLORED BANDS ON  
ABOVE TUBE GEL

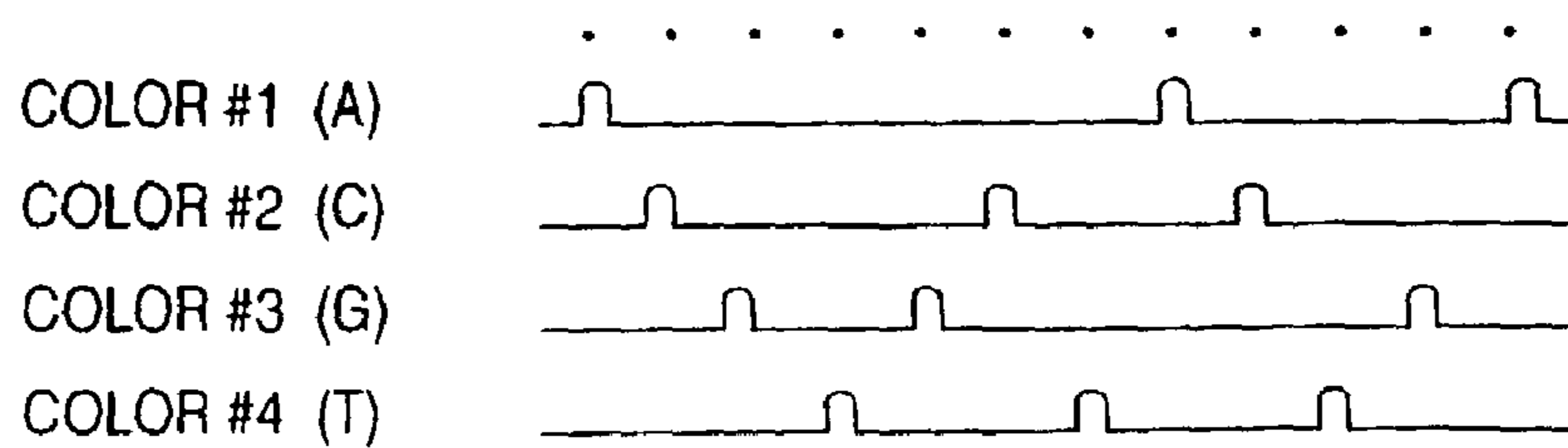

FIG. 3

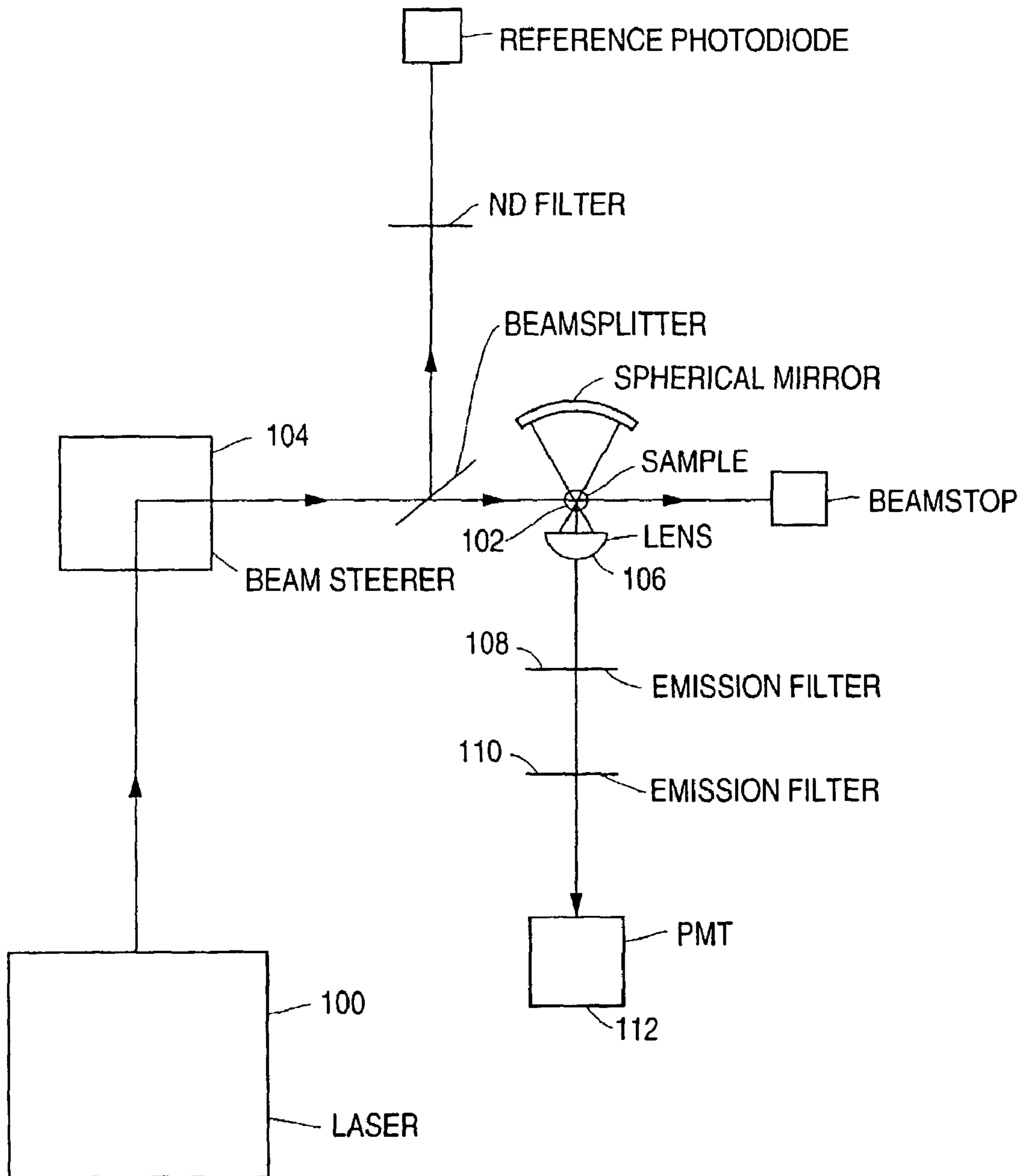

FIG. 4

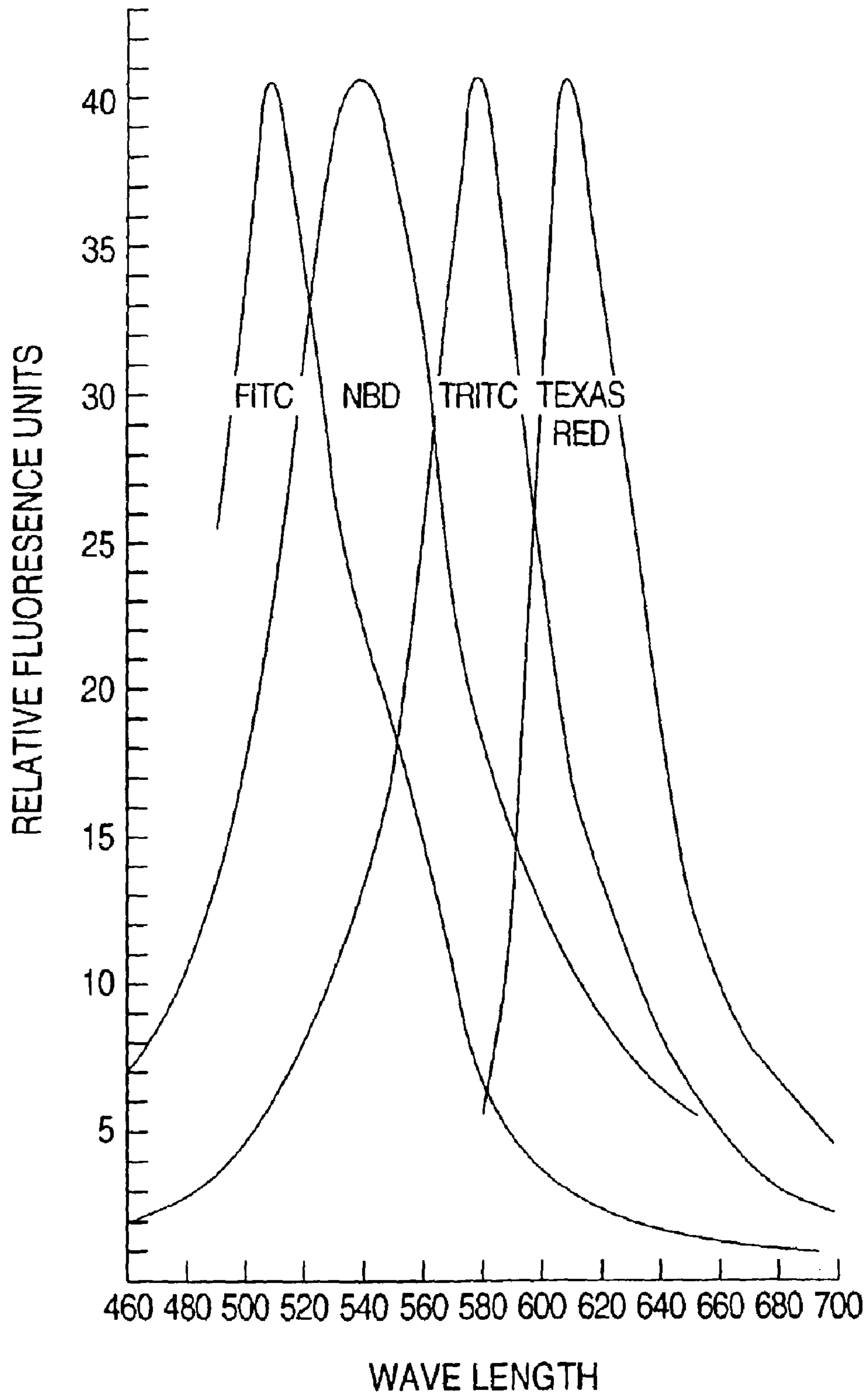

FIG. 5

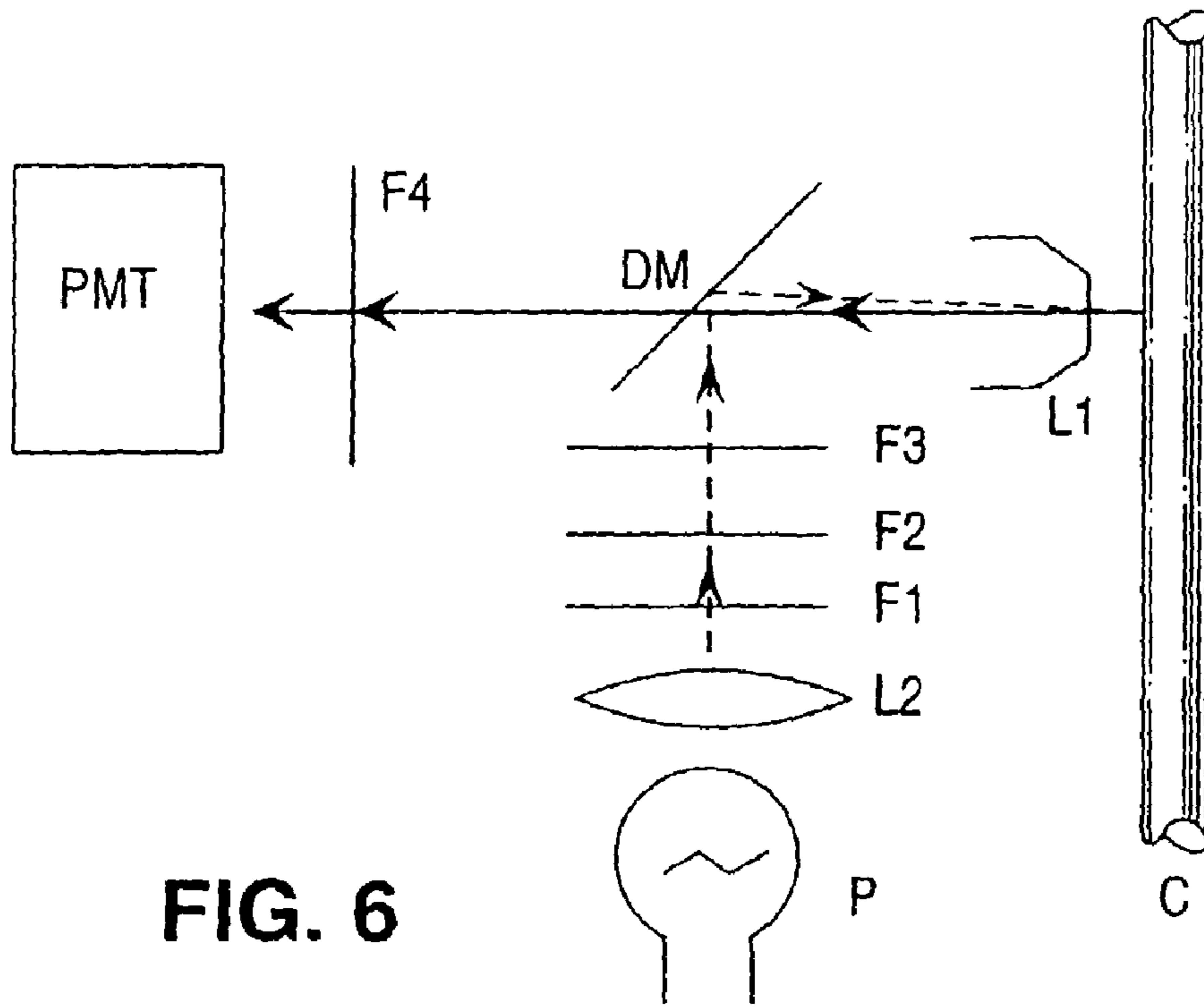

FIG. 6

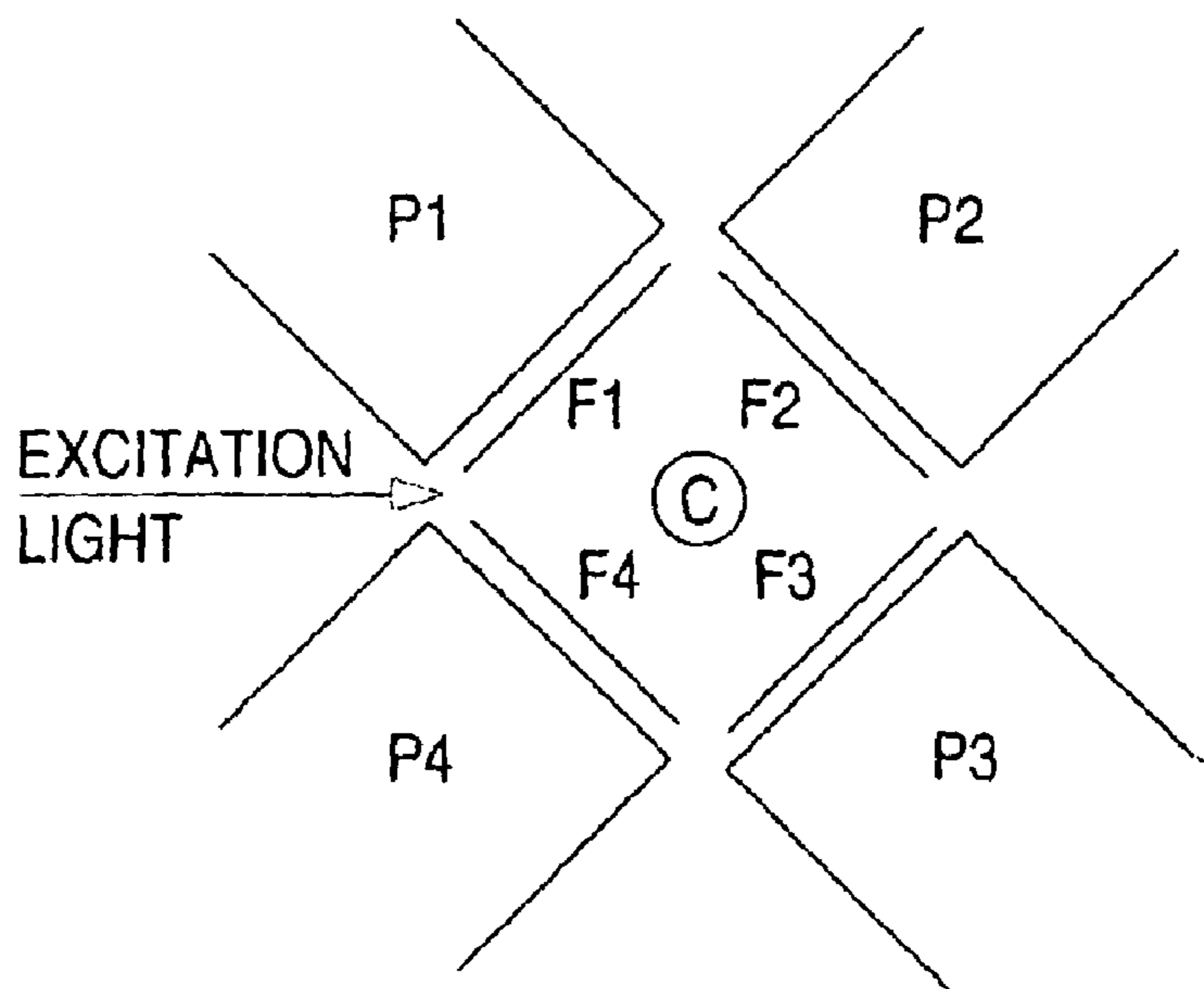

FIG. 7

## TAGGED EXTENDABLE PRIMERS AND EXTENSION PRODUCTS

**Matter enclosed in heavy brackets [ ] appears in the original patent but forms no part of this reissue specification; matter printed in italics indicates the additions made by reissue.**

This application is a continuation of application Ser. No. 08/361,176 filed Dec. 21, 1994, now U.S. Pat. No. 5,821,058 which is a continuation of application Ser. No. 07/898,019, filed Jun. 12, 1992, now abandoned, which is a continuation of application Ser. No. 07/660,160, filed Feb. 21, 1991, now abandoned, which is a continuation of application Ser. No. 07/106,232, filed Oct. 7, 1987, now abandoned, which is a CIP of application Ser. No. 06/722,742, filed Apr. 11, 1985, now abandoned, which is CIP of application Ser. No. 06/689,013, filed Jan. 2, 1985, now abandoned, which is a CIP of application Ser. No. 06/570,973, filed Jan. 16, 1984, now abandoned.

### BACKGROUND OF THE INVENTION

The development of reliable methods for sequence analysis of DNA (deoxyribonucleic acid) and RNA (ribonucleic acid) has been one of the keys to the success of recombinant DNA and genetic engineering. When used with the other techniques of modern molecular biology, nucleic acid sequencing allows dissection and analysis of animal, plant and viral genomes into discrete genes with defined chemical structure. Since the function of a biological molecule is determined by its structure, defining the structure of a gene is crucial to the eventual manipulation of this basic unit of hereditary information in useful ways. Once genes can be isolated and characterized, they can be modified to produce desired changes in their structure that allow the production of gene products—proteins—with different properties than those possessed by the original proteins. Microorganisms into which the natural or synthetic genes are placed can be used as chemical “factories” to produce large amounts of scarce human proteins such as interferon, growth hormone, and insulin. Plants can be given the genetic information to allow them to survive harsh environmental conditions or produce their own fertilizer.

The development of modern nucleic acid sequencing methods involved parallel developments in a variety of techniques. One was the emergence of simple and reliable methods for cloning small to medium-sized strands of DNA into bacterial plasmids, bacteriophages, and small animal viruses. This allowed the production of pure DNA in sufficient quantities to allow its chemical analysis. Another was the near perfection of gel electrophoretic methods for high resolution separation of oligonucleotides on the basis of their size. The key conceptual development, however, was the introduction of methods of generating size-nested sets of fragments cloned, purified DNA that contain, in their collection of lengths, the information necessary to define the sequence of the nucleotides comprising the parent DNA molecules.

Two DNA sequencing methods are in widespread use. These are the method of Sanger, F., Nicklen, S. and Coulson, A. R. Proc. Natl. Acad. Sci. U.S.A. 74, 5463 (1977) and the method of Maxam, A. M. and Gilbert, W. Methods in Enzymology 65, 499-599 (1980).

The method developed by Sanger is referred to as the dideoxy chain termination method. In the most commonly

used variation of this method, a DNA segment is cloned into a single-stranded DNA phage such as M13. These phage DNAs can serve as templates for the primed synthesis of the complementary strand by the Klenow fragment of DNA polymerase I. The primer is either a synthetic oligonucleotide or a restriction fragment isolated from the parental recombinant DNA that hybridizes specifically to a region of the M13 vector near the 3' end of the cloned insert. In each of four sequencing reactions, the primed synthesis is carried out in the presence of enough of the dideoxy analog of one of the four possible deoxynucleotides so that the growing chains are randomly terminated by the incorporation of these “dead-end” nucleotides. The relative concentration of dideoxy to deoxy forms is adjusted to give a spread of termination events corresponding to all the possible chain lengths that can be resolved by gel electrophoresis. The products from each of the four primed synthesis reactions are then separated on individual tracks of polyacrylamide gels by the electrophoresis. Radioactive tags incorporated in the growing chains are used to develop an autoradiogram image of the pattern of the DNA in each electrophoresis track. The sequence of the deoxynucleotides in the cloned DNA is determined from an examination of the pattern of bands in the four lanes.

The method developed by Maxam and Gilbert uses chemical treatment of purified DNA to generate size-nested sets of DNA fragments analogous to those produced by the Sanger method. Single or double-stranded DNA, labeled with radioactive phosphate at either the 3' or 5' end, can be sequenced by this procedure. In four sets of reactions, cleavage is induced at one or two of the four nucleotide bases by chemical treatment. Cleavage involves a three-stage process: modification of the base, removal of the modified base from its sugar, and strand scission at that sugar. Reaction conditions are adjusted so that the majority of end-labeled fragments generated are in the size range (typically 1 to 400 nucleotides) that can be resolved by gel electrophoresis. The electrophoresis, autoradiography, and pattern analysis are carried out essentially as is done for the Sanger method. (Although the chemical fragmentation necessarily generates two pieces of DNA each time it occurs, only the piece containing the end label is detected on the autoradiogram.)

Both of these DNA sequencing methods are in widespread use, and each has several variations.

For each, the length of sequence that can be obtained from a single set of reactions is limited primarily by the resolution of the polyacrylamide gels used for electrophoresis. Typically, 200 to 400 bases can be read from a single set of gel tracks. Although successful, both methods have serious drawbacks, problems associated primarily with the electrophoresis procedure. One problem is the requirement of the use of radiolabel as a tag for the location of the DNA bands in the gels. One has to contend with the short half-life of phosphorus-32, and hence the instability of the radiolabeling reagents, and with the problems of radioactive disposal and handling. More importantly, the nature of autoradiography (the film image of a radioactive gel band is broader than the band itself) and the comparison of band positions between four different gel tracks (which may or may not behave uniformly in terms of band mobilities) can limit the observed resolution of bands and hence the length of sequence that can be read from the gels. In addition, the track-to-track irregularities make automated scanning of the autoradiograms difficult—the human eye can presently compensate for these irregularities much better than computers can. This need for manual “reading” of the autoradiograms is time-consuming, tedious and error-prone. Moreover, one cannot read the gel patterns while the electrophoresis is actually being performed, so as to be able to

3

terminate the electrophoresis once resolution becomes insufficient to separate adjoining bands, but must terminate the electrophoresis at some standardized time and wait for the autoradiogram to be developed before the sequence reading can begin.

An oligonucleotide is a short polymer consisting of a linear sequence of four nucleotides in a defined order. The nucleotide subunits are joined by phosphodiester linkages joining the 3' hydroxyl moiety of one nucleotide to the 5' hydroxyl moiety of the next nucleotide. An example of an oligonucleotide is 5' ApCpGpTpApTpGpGpCp 3'. The letters A, C, G and T refer to the nature of the purine or pyrimidine base coupled at the 1-position of deoxyribose. A, adenine; C, cytosine; G, guanine; T, thymidine. P represents the phosphodiester bond. The structure of a section of an oligonucleotide is shown below.

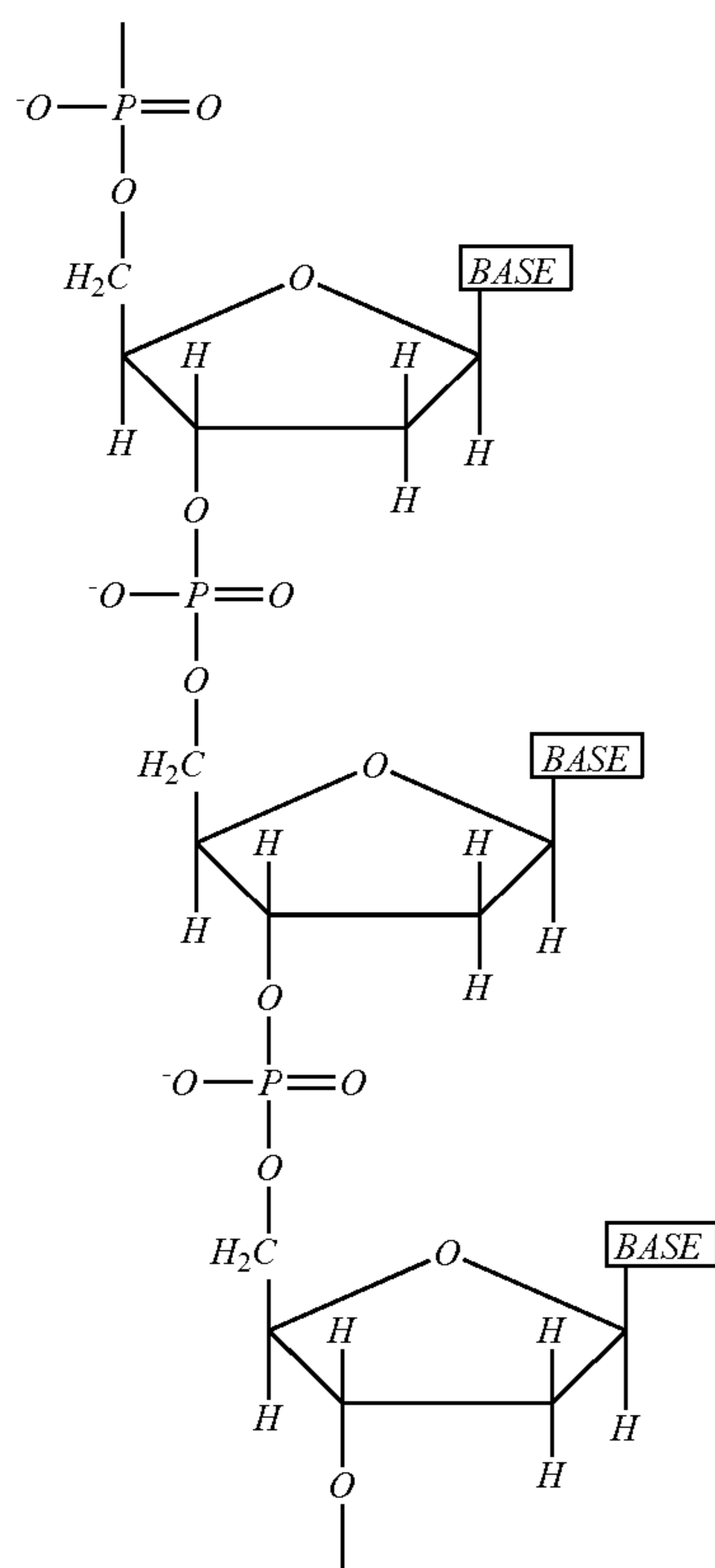

The single stranded oligonucleotides of this invention are further characterized by being homogenous with respect to the sequence of the nucleoside subunits and are of uniform molecular weight.

Synthetic oligonucleotides are powerful tools in modern molecular biology and recombinant DNA work. There are numerous applications for these molecules, including a) as probes for the isolation of specific genes based on the protein sequence of the gene product, b) to direct the *in vitro* mutagenesis of a desired gene, c) as primers for DNA synthesis on a single-stranded template, d) as steps in the total synthesis of genes, and many more, reviewed in Wm. R. Bahl *et al*, *Prog. Nucl. Acid Res. Mol. Biol.*, 21, 101 (1978).

A very considerable amount of effort has therefore been devoted to the development of efficient chemical methods for the synthesis of such oligonucleotides. A brief review of these methods as they have developed to the present is found in Crockett, G. C., *Aldrichimica Acta* 16(3), 47-55 (1983). The

4

best methodology currently available utilizes the phosphoramidite derivatives of the nucleosides in combination with a solid phase synthetic procedure, Matteucci *et al*, *J. Am. Chem. Soc.*, 103, 3185 (1981); and Beaucage *et al*, *M. H. Tet. Lett.*, 22 (20), 1858-1862 (1981). Oligonucleotides of length up to 30 bases may be made on a routine basis in this matter, and molecules as long as 50 bases have been made. Machines that employ this technology are now commercially available.

There are other reports in the literature of the derivitization of DNA. A modified nucleoside triphosphate has been developed wherein a biotin group is conjugated to an aliphatic amino group at the 5 position of uracil, Langer *et al*, *Proc. Nat. Acad. Sci., U.S.A.*, 78, 6633-6637 (1981). This nucleotide derivative is effectively incorporated into double stranded DNA. Once in DNA it may be bound by anti-biotin antibody which can then be used for detection by fluorescence or enzymatic methods. The DNA which has had biotin conjugated nucleosides incorporated therein by the method of Langer *et al* is fragmented into smaller single and double stranded pieces which are heterogeneous with respect to the sequence of nucleoside subunits and variable in molecular weight. Draper and Gold, *Biochemistry*, 19, 1774-1781 (1980), reported the introduction of aliphatic amino groups by a bisulfite catalyzed transamination reaction, and their subsequent reaction with the fluorescent tag. In Draper and Gold the amino group is attached directly to the pyrimidine base. The amino group so positioned inhibits hydrogen bonding and for this reason, these materials are not useful in hybridization and the like. Chu *et al*, *Nucleic Acid Res.* 11(18), 6513-6529 (1983), have reported a method for attaching an amine to the terminal 5' phosphate of oligonucleotides or nucleic acids.

There are many reasons to want a method for covalently attaching other chemical species to synthetic oligonucleotides. Fluorescent dyes attached to the oligonucleotides permits one to eliminate radioisotopes from the research, diagnostic and clinical procedures in which they are used, and improve shelf-life availability. As described in the assignee's co-pending application for a DNA sequencing machine (Serial No. the synthesis of fluorescent-labeled oligonucleotides permits the automation of the DNA sequencing process.

The invention of the present patent application addresses these and other problems associated with DNA sequencing procedures and is believed to represent a significant advance in the art. The preferred embodiment of the present invention represents a further and distinct improvement.

#### SUMMARY OF THE INVENTION

Briefly, this invention comprises a novel process for the electrophoretic analysis of DNA fragments produced in DNA sequencing operations wherein chromophores or fluorophores are used to tag the DNA fragments produced by the sequencing chemistry and permit the detection and characterization of the fragments as they are resolved by electrophoresis through a gel. The detection employs an absorption or fluorescent photometer capable of monitoring the tagged bands as they are moving through the gel.

This invention further comprises a novel process for the electrophoretic analysis of DNA fragments produced in DNA sequencing operations wherein a set of four chromophores are used to tag the DNA fragments produced by the sequencing chemistry and permit the detection and characterization of the fragments as they are resolved by electrophoresis through a gel; the improvement wherein the four different fragment sets are tagged with the fluorophores fluorescein, Texas Red, tetramethyl rhodamine, and 7-nitrobenzofurazan.

## 5

This invention also includes a novel system for the electrophoretic analysis of DNA fragments produced in DNA sequencing operations comprising:

a source of chromophore or fluorescent tagged DNA fragments.

a zone for containing an electrophoresis gel, means for introducing said tagged DNA fragments to said zone; and

photometric means for monitoring or detecting said tagged DNA fragments as they move through and are separated by said gel.

It is an object of this invention to provide a novel process for the sequence analysis of DNA.

It is another object of our invention to provide a novel system for the analysis of DNA fragments.

More particularly, it is an object of this invention to provide an improved process for the sequence analysis of DNA.

These and other objects and advantages of this invention will be apparent from the detailed description which follows.

## BRIEF DESCRIPTION OF THE DRAWINGS

Turning to the drawings:

FIG. 1 is an illustration of one means of end-labeling a DNA fragment with a fluorescent tag. Pst. I and T4 DNA ligase are enzymes commonly used in recombinant DNA research.

FIG. 2 is a block diagram of automated DNA sequencer, gel electrophoretic system.

FIG. 3 is a comparison of the type of data produced by DNA sequencing of the sequence shown in FIG. 1.

FIG. 4 is a block diagram of a preferred DNA sequencer according to this invention.

FIG. 5 shows the emission spectra for the four fluorophores used as tags in the preferred embodiment of this invention.

FIG. 6 is a schematic diagram of a possible optical configuration in the detector unit. P, lamp source; L1, objective lens; L2, collimating lens; F1, UV blocking filter; F2, heat blocking filter; F3, band pass excitation filter; F4, long pass emission filter; DM, dichroic mirror; C, polyacrylamide gel; PMT, photomultiplier tube.

FIG. 7 is a schematic diagram of another possible optical configuration in the detector unit. F1 to F4 are bandpass filters centered at the emission maximum of the different dyes. P1 to P4 are photomultiplier tubes. The excitation light is of a wavelength such that it is not transmitted through any of the filters F1 to F4.

## DETAILED DESCRIPTION OF THE INVENTION

In the previous methods of DNA sequencing, including those based on the Sanger dideoxy chain termination method, a single radioactive label, phosphorus-32, is used to identify all bands on the gels. This necessitates that the fragment sets produced in the four synthesis reactions be run on separate gel tracks and leads to the problems associated with comparing band mobilities in the different tracks. This problem is overcome in the present invention by the use of a set of four chromophores or fluorophores with different absorption or fluorescent maxima, respectively. Each of these tags is coupled chemically to the primer used to initiate the synthesis of the fragment strands. In turn, each tagged primer is then paired with one of the dideoxynucleotides and used in the primed synthesis reaction with the Klenow fragment of DNA polymerase.

The primers must have the following characteristics. 1) They must have a free 3' hydroxyl group to allow chain

## 6

extension by the polymerase. 2) They must be complementary to a unique region 3' of the cloned insert. 3) They must be sufficiently long to hybridize to form a unique, stable duplex. 4) The chromophore or fluorophore must not interfere with the hybridization or prevent 3'-end extension by the polymerase.

Conditions 1, 2 and 3 above are satisfied by several synthetic oligonucleotide primers which are in general use for Sanger-type sequencing utilizing M13 vectors.

One such primer is the 15 mer 5' CCC AG TCA CGA CGT T 3' where A, C, G and T represent the four different nucleoside components of DNA; A, adenosine; C, cytosine; G, guanosine; T, thymidine.

In the preferred embodiment of the present invention a set of four fluorophores with different emission spectra, respectively, are used. These different emission spectra are shown in FIG. 5. Each of these tags is coupled chemically to the primer used to initiate the synthesis of the fragment strands. In turn, each tagged primer is then paired with one of the dideoxynucleotides and used in the primed synthesis reaction with the Klenow fragment of DNA polymerase.

The dyes used must have high extinction coefficients and/or reasonably high quantum yields for fluorescence. They must have well resolved adsorption maxima and/or emission maxima. Representative of such amino reactive dyes are: fluorescein isothiocyanate (FITC,  $\lambda_{max}^{Ex}=495$ ,  $\lambda_{max}^{Em}=520$ ,  $\epsilon_{495}\cong 8\times 10^4$ ), tetramethyl rhodamine isothiocyanate (TMRITC,  $\lambda_{max}^{Ex}=550$ ,  $\lambda_{max}^{Em}=578$ ,  $\epsilon_{550}\cong 4\times 10^4$ ), and substituted rhodamine isothiocyanate (XRITC,  $\lambda=580$ ,  $\lambda_{max}^{Em}=604$ ,  $\epsilon_{580}\cong 8\times 10^4$ )

where  $\lambda$  represents the wavelength in nanometers, Ex is excitation, Em is emission, max is maximum, and  $\epsilon$  is the molar extinction coefficient. These dyes have been attached to the M13 primer and the conjugates electrophoresed on a 20% polyacrylamide gel. The labeled primers are visible by both their absorption and their fluorescence in the gel. All four labeled primers have identical electrophoretic mobilities. The dye conjugated primers retain their ability to specifically hybridize to DNA, as demonstrated by their ability to replace the underivatized oligonucleotide normally used in the sequencing reactions.

The chemistry for the coupling of the chromophoric or fluorophoric tags is described in assignee's copending patent applications Ser. No. 565,010, filed Dec. 20, 1983, now abandoned, and Ser. No. 709,579, filed Mar. 8, 1985, the disclosures of which are expressly incorporated herein by reference. The strategy used is to introduce an aliphatic amino group at the 5' terminus as the last addition in the synthesis of the oligonucleotide primer. This reactive amino group may then readily be coupled with a wide variety of amino reactive fluorophores or chromophores. This approach aids compatibility of the labeled primers with condition 4 above.

End Labeling of DNA for Use With Maxam/Gilbert Method. In the Maxam/Gilbert method of DNA sequencing, the end of the piece of DNA whose sequence is to be determined must be labeled. This is conventionally done enzymatically using radioactive nucleosides. In order to use the Maxam/Gilbert method in conjunction with the dye detection scheme described in this invention, the DNA piece must be labeled with dyes. One manner in which this maybe accomplished is shown in FIG. 1. Certain restriction endonucleases generate what is known as a 3' overhang as the product of DNA cleavage. These enzymes generate a "sticky end," a short stretch of single stranded DNA at the end of a piece of double stranded DNA. This region will anneal with a complementary stretch of DNA, which may be covalently joined to the duplex DNA with the enzyme ligase. In this manner one of



the strands is covalently linked to a detectable moiety. This moiety may be a dye, an amino group or a protected amino group (which could be deprotected and reacted with dye subsequent to the chemical reactions).

Sequencing Reactions. The dideoxy sequencing reactions are performed in the standard fashion Smith, A. J. H., *Methods in Enzymology* 65, 560–580 (1980), except that the scale may be increased if necessary to provide an adequate signal intensity in each band for detection. The reactions are done using a different color primer for each different reaction. No radiolabeled nucleoside triphosphate need be included in the sequencing reaction.

The Maxam/Gilbert sequencing reactions are performed in the usual manner, Gil, S. F. *Aldrichimica Acta* 16(3), 59–61 (1983), except that the end label is either one or four colored dyes, or a free or protected amino group which may be reacted with dye subsequently.

Detection. There are many different ways in which the tagged molecules which have been separated by length using polyacrylamide gel electrophoresis may be detected. Four illustrative modes are described below. These are i) detection of the fluorescence excited by light of different wavelengths for the different dyes, ii) detection of fluorescence excited by light of the same wavelength for the different dyes, iii) elution of the molecules from the gel and detection by chemiluminescence, and iv) detection by the absorption of light by molecules. In modes i) and ii) the fluorescence detector should fulfill the following requirements. a) The excitation light beam should not have a height substantially greater than the height of a band. This is normally in the range of 0.1 to 0.5 mm. The use of such a narrow excitation beam allows the attainment of maximum resolution of bands. b) The excitation wavelength can be varied to match the absorption maxima of each of the different dyes or can be a single narrow, high intensity light band that excites all four fluorophores and does not overlap with any of the fluorescence emission. c) The optical configuration should minimize the flux of scattered and reflected excitation light to the photodetector **14**. The optical filters to block out scattered and reflected excitation light are varied as the excitation wavelength is varied. d) The photodetector **14** should have a fairly low noise level and a good spectral response and quantum efficiency throughout the range of the emission of the dyes (500 to 600 nm for the dyes listed above). e) The optical system for collection of the emitted fluorescence should have a high numerical aperture. This maximizes the fluorescence signal. Furthermore, the depth of field of the collection optics should include the entire width of the column matrix.

Two illustrative fluorescence detection systems are diagrammed in FIGS. 6 and 7. The system in FIG. 6 is compatible with either single wavelength excitation or multi wavelength excitation. For single wavelength excitation, the filter **F4** is one of four band pass filters centered at the peak emission wavelength of each of the dyes. This filter is switched every few seconds to allow continual monitoring of each of the four fluorophores. For multi wavelength excitation, the optical elements **F3** (excitation filter), **DM** (dichroic mirror), and **F4** (barrier filter) are switched together. In this manner both the excitation light and the observed emission light are varied. The system in FIG. 7 is a good arrangement for the case of single wavelength excitation. This system has the advantage that no moving parts are required, and fluorescence from all four of the dyes may be simultaneously and continuously monitored. A third approach (iii above) to detection is to elute the labeled molecules at the bottom of the gel, combine them with an agent for excitation of chemiluminescence such as 1,2 dioxetane dione, Gill, S. K. *Aldrichimica Acta* 16(3), 59–61 (1983); Mellbin, G. J. *Liq. Chrom.* 6(9), 1603–1616 (1983), and flow the mixture directly into a detector which can measure the emitted light at four separate wavelengths.

The background signal in chemiluminescence is much lower than in fluorescence, resulting in higher signal to noise ratios and increased sensitivity. Finally, the measurement may be made by measurements of light absorption (iv above). In this case, a light beam of variable wavelength is passed through the gel, and the decrease in the beam intensity due to absorption of light at the different wavelengths corresponding to the absorption maximum of the four dyes, it is possible to determine which dye molecule is in the light path. As disadvantage of this type of measurement is that absorption measurements are inherently less sensitive than fluorescence measurements.

The above-described detection system is interfaced to a computer **16**. In each time interval examined, the computer **16** receives a signal proportional to the measured signal intensity at that time for each of the four colored tags. This information tells which nucleotide terminates the DNA fragment of the particular length in the observation window at that time. The temporal sequence of colored bands gives the DNA sequence. In FIG. 3 is shown the type of data obtained by conventional methods, as well as the type of data obtained by the improvements described in this invention.

The following Examples are presented solely to illustrate the invention. In the Examples, parts and percentages are by weight unless otherwise indicated.

#### EXAMPLE I

Gel electrophoresis. Aliquots of the sequencing reactions are combined and loaded onto a 5% polyacrylamide column **10** shown in FIG. 2 from the upper reservoir **12**. The relative amounts of the four different reactions in the mixture are empirically adjusted to give approximately the same fluorescence or absorptive signal intensity from each of the dye DNA conjugates. This permits compensation for differences in dye extinction coefficients, dye fluorescence quantum yields, detector sensitivities and so on. A high voltage is placed across the column **10** so as to electrophorese the labeled DNA fragments through the gel. The labeled DNA segments differing in length by a single nucleotide are separated by electrophoresis in this gel matrix. At or near the bottom of the gel column **10**, the bands of DNA are resolved from one another and pass through the detector **14** (more fully described above). The detector **14** detects the fluorescent or chromophoric bands of DNA in the gel and determines their color, and therefore to which nucleotide they correspond. This information yields the DNA sequence.

#### EXAMPLE II

FIG. 4 shows a block diagram of a DNA sequenator for use with one dye at a time. The beam (4880 Å) from an argon ion laser **100** is passed into the polyacrylamide gel tube (sample) **102** by means of a beamsteerer **104**. Fluorescence excited by the beam is collected using a low f-number lens **106**, passed through an appropriate set of optical filters **108** and **110** to eliminate scattered excitation light and detected using a photomultiplier tube (PMT) **112**. The signal is readily detected on a strip chart recorder. DNA sequencing reactions are carried out utilizing a fluorescein labeled oligonucleotide primer. The peaks on the chart correspond to fragments to fluorescein labeled DNA of varying lengths synthesized in the sequencing reactions and separated in the gel tube by electrophoresis. Each peak contains on the order of  $10^{-15}$  to  $10^{-16}$  moles of fluorescein, which is approximately equal to the amount of DNA obtained per band in an equivalent sequencing gel utilizing radioisotope detection. This proves that the fluorescent tag is not removed or degraded from the oligonucleotide primer in the sequencing reactions. It also demonstrates that the detection sensitivity is quite adequate to perform DNA sequence analysis by this means.

## Materials

Fluorescein-5-isothiocyanate (FITC) and Texas Red were obtained from Molecular Probes, Inc. (Junction City, Oreg.). tetramethyl rhodamine isothiocyanate (TMRITC) was obtained from Research Organics, Inc. (Cleveland, Ohio). 4-fluoro-7-nitro-benzofurazan (NBD-fluoride) was obtained from Sigma Chemical Co. (St. Louis, Mo.). Absorption spectra were obtained on a H/P 8491 spectrophotometer. High performance liquid chromatography was performed on a system composed of two Altex 110A pumps, a dual chamber gradient mixer, Rheodyne injector, Kratos 757 UV detector, and an Axxiom 710 controller.

## EXAMPLE III

Addition of 5'-aminothymidine phosphoramidites to oligonucleotides.

The protected 5'-aminothymidine phosphoramidites, 5'-(N-9-fluorenylmethyloxycarbonyl)-5'-amino-5'-deoxy-3'-N, N-diisopropylaminomethoxyphosphinyl thymidine, is coupled to the 5'-hydroxyl of an oligonucleotide using well established DNA synthetic procedures. The solvents and reaction conditions used are identical to those used in oligonucleotide synthesis.

## EXAMPLE IV

## Dye Conjugation

The basic procedure used for the attachment of fluorescent dye molecules to the amino oligonucleotides is to combine the amino oligonucleotide and the dye in aqueous solution buffered to pH 9, to allow the reaction to stand at room temperature for several hours, and then to purify the product in two stages. The first purification step is to remove the bulk of the unreacted or hydrolyzed dye by gel filtration. The second purification stage is to separate the dye conjugate from unreacted oligonucleotide by reverse phase high performance liquid chromatography. Slight variations upon these conditions are employed for the different dyes, and the specific procedures and conditions used for four particular dyes are given below and in Table 1.

TABLE 1

Reverse Phase HPLC Conditions for Dye-oligonucleotide Purification	
Sample	Retention time
PLP-15 <sup>a</sup>	18'
PLP-15-T-NH <sub>2</sub> <sup>b</sup>	18'
FITC PLP-15 <sup>c</sup>	27'
NBD PLP-15	25'
TMRITC PLP-15	32' and 34' <sup>d</sup>
Texas Red PLP-15	42'

Retention times shown are for HPLC gradients of 20% solvent B/80% solvent A to 60% solvent B/40% solvent A in 40 min., where solvent A is 0.1 M triethylammonium acetate pH 7.0 and solvent B is 50% acetonitrile, 50% 0.1 M triethylammonium acetate pH 7.0. The column was an Axxiom ODS 5 micron C 18 column #555-102 available from Cole Scientific, Calabasas, CA. This gradient is not optimized for purification of PLP-15 and PLP-15-T-NH<sub>2</sub>, but the retention times are included for comparison with the dye primer conjugates.

<sup>a</sup>PLP-15 is an oligonucleotide primer for DNA sequence analysis in the M13 vectors. Its sequence is 5'CCC AGT CAC GAC FTT 3'.

<sup>b</sup>PLP-15-T-NH<sub>2</sub> is the oligonucleotide PLP-15 to which a 5'-amino-5'-deoxythymidine base has been added to the 5' terminus.

<sup>c</sup>The nomenclature Dye PLP-15 signifies the conjugate of PLP-15-T-NH<sub>2</sub> and the dye molecule.

<sup>d</sup>Two fluorescent oligonucleotide products were obtained with TMRITC. Both were equally effective in sequencing. This is presumed to be due to the two isomers of TMRITC which are present in the commercially available material.

The following procedure is for use with fluorescein isothiocyanate or 4-fluoro-7-nitro-benzofurazan. Amino oligonucleotide (0.1 ml of ~1 mg/ml oligonucleotide in water) is combined with 1 M sodium carbonate/bicarbonate buffer pH 9 (50

μl), 10 mg/ml dye in dimethylformamide (20 μl) and H<sub>2</sub>O (80 μl). This mixture is kept in the dark at room temperature for several hours. The mixture is applied to a 10 ml column of Sephadex G-25 (medium) and the colored band of material eluting in the excluded volume is collected. The column is equilibrated and run in water. In control reactions with underivatized oligonucleotides, very little if any dye is associated with the oligonucleotide eluting in the void volume. The colored material is further purified by reverse phase high performance liquid chromatography on an Axxiom C<sub>18</sub> column (#555-102, Cole Scientific, Calabasas, Calif.) in a linear gradient of acetonitrile:0.1 M triethylammonium acetate, pH 7.0. It is convenient for this separation to run the column eluant through both a UV detector (for detecting the DNA absorbance) and a fluorescence detector (for detecting the dye moiety). The desired product is a peak on the chromatogram which is both strongly UV absorbing and strongly fluorescent. The dye oligonucleotide conjugates elute at higher acetonitrile concentrations than the oligonucleotides alone, as shown in Table 1. The oligonucleotide is obtained from the high performance liquid chromatography in solution in a mixture of acetonitrile and 0.1 M triethylammonium acetate buffer. This is removed by lyophilization and the resulting material is redissolved by vortexing in 10 mM sodium hydroxide (for a minimum amount of time) followed by neutralization with a five fold molar excess (to sodium hydroxide) of Tris buffer, pH 7.5.

The conjugation with Texas Red is identical to that described for fluorescein isothiocyanate and 4-fluoro-7-nitro-benzofurazan, except that:

- prior to separation on Sephadex G-25 the reaction is made 1 M in ammonium acetate and kept at room temperature for 30 minutes, and
- the Sephadex G-25 column is run in 0.1 M ammonium acetate. This largely eliminates nonspecific binding of the dye molecule to the oligonucleotide.

The conjugation with tetramethyl rhodamine isothiocyanate cyanate is identical to that for Texas Red except that the reaction is carried out in 10 mM sodium carbonate/bicarbonate buffer, pH 9.0, and 50% dioxane. This increases solubility of the tetramethyl rhodamine and a much higher yield of dye oligonucleotide conjugate is obtained.

In some cases, particularly with the rhodamine-like dyes, a substantial amount of nonspecific binding of dye was observed, as manifested by an inappropriately large dye absorption present in the material eluted from the gel filtration column. In these cases the material was concentrated and reapplied to a second gel filtration column prior to high performance liquid chromatography purification. This generally removed the majority of the noncovalently associated dye.

## EXAMPLE V

## Properties of Dye-Oligonucleotide Conjugates

The development of chemistry for the synthesis of dye oligonucleotide conjugates allows their use as primers in DNA sequence analysis. Various fluorescent dye primers have been tested by substituting them for the normal primer in DNA sequence analysis by the enzymatic method. An autoradiogram of a DNA sequencing gel in which these dye-conjugated primers were utilized in T reactions in place of the normal oligonucleotide primer was prepared. This autoradiogram was obtained by conventional methods employing α-<sup>32</sup>P-dCTP as a radiolabel. The autoradiogram showed that the underivatized primer, amino-derivitized primer, and dye conjugated primers all give the same pattern of bands (corresponding to the DNA sequence), indicating that the deriv-

## 11

itized primers retain their ability to hybridize specifically to the complementary strand. Secondly, the bands generated using the different primers differ in their mobilities, showing that it is indeed the dye-primers which are responsible for the observed pattern, and not a contaminant of unreacted or underivatized oligonucleotide. Thirdly, the intensity of the bands obtained with the different primers is comparable, indicating that the strength of hybridization is not significantly perturbed by the presence of the dye molecules.

The separations are again carried out in an acrylamide gel column. The beam from an argon ion laser is passed into the polyacrylamide gel tube (sample) by means of a beamsteerer. Fluorescence excited by the beam is collected using a low f-number lens, passed through an appropriate set of optical filters to eliminate scattered excitation light and detected using a photomultiplier tube (PMT). The signal is monitored on a strip chart recorder. DNA sequencing reactions have been carried out utilizing each of the four different dye coupled oligonucleotide primers. In each case a series of peaks are observed on the chart paper. The peaks correspond to fragments of dye labeled DNA of varying lengths synthesized in the sequencing reactions and separated in the gel tube by electrophoresis. Each peak contains of the order of  $10^{-14}$  to  $10^{-16}$  moles of dye, which is approximately equal to the amount of DNA obtained per band in an equivalent sequencing gel utilizing radioisotope detection. This proves that the fluorescent tag is not removed or degraded from the oligonucleotide primer in the sequencing reactions. It also demonstrates that the detection sensitivity is quite adequate to perform DNA sequence analysis by this means, and that adequate resolution of the DNA fragments is obtained in a tube gel system.

Having fully described the invention it is intended that it be limited only by the lawful scope of the appended claims.

What is claimed is:

[1. A duplex comprising an oligonucleotide primer and a template, wherein the primer is covalently coupled to a chromophore or fluorophore so as to allow chain extension by a polymerase.]

[2. A duplex comprising an extended oligonucleotide primer and a template, produced by providing a duplex according to claim 1 and extending the oligonucleotide primer with a polymerase.]

[3. A single-stranded labeled polynucleotide produced by separating the extended oligonucleotide primer from the duplex of claim 2.]

[4. A set of duplexes comprising two or more of the duplexes of claim 1.]

[5. A set of duplexes comprising two or more of the duplexes of claim 2.]

[6. A set of polynucleotides comprising two or more single-stranded labeled polynucleotides of claim 3.]

[7. A set of reagents comprising oligonucleotide primers covalently coupled to one or more chromophores or fluorophores so as to allow chain extension by a polymerase, and a polymerase.]

[8. A single-stranded labeled polynucleotide comprising a first portion and a second portion,

wherein the first portion comprises an oligonucleotide primer covalently coupled to a chromophore or fluorophore; and

wherein the second portion is produced by extension of the first portion along a complementary template.]

[9. The polynucleotide of claim 8, wherein the chromophore or fluorophore is covalently coupled to the first portion through an amine linkage.]

## 12

[10. The polynucleotide of claim 8, wherein the chromophore or fluorophore is covalently coupled to the first portion at its 5' end.]

[11. The duplex of claim 1, prepared by a method comprising hybridizing an oligonucleotide primer to a template, wherein the primer is covalently coupled to a chromophore or fluorophore so as to allow chain extension by a polymerase.]

[12. The duplex of claim 11, wherein the chromophore or fluorophore is covalently coupled to the primer through an amine linkage.]

[13. The duplex of claim 11, wherein the chromophore or fluorophore is covalently coupled to the primer at its 5' end.]

[14. A single-stranded labeled polynucleotide produced by the method comprising the steps of extending the oligonucleotide primer of the duplex of claim 1 by a polymerase to produce a labeled polynucleotide and separating the labeled polynucleotide from the template.]

[15. The polynucleotide of claim 14, wherein the chromophore or fluorophore is covalently coupled to the oligonucleotide through an amine linkage.]

[16. The polynucleotide of claim 14, wherein the chromophore or fluorophore is covalently coupled to the oligonucleotide at its 5' end.]

[17. A chain termination DNA sequencing method comprising extending the primer of the duplex of claim 1 by a polymerase to produce a labeled polynucleotide, and separating the labeled polynucleotide from the template.]

[18. A chain termination DNA sequencing method comprising extending the primers of the set of duplexes of claim 4 by a polymerase to produce a set of labeled polynucleotides.]

[19. The chain termination DNA sequencing method of claim 18, wherein the set of duplexes comprises four DNA sequencing reactions, wherein each labeled polynucleotide is distinguishable by spectral characteristics of the chromophore or fluorophore covalently coupled thereto.]

[20. The oligonucleotide primer of claim 1, wherein the primer is DNA.]

[21. The oligonucleotide primer of claim 1 wherein the chromophore or fluorophore is detectable by exposure to a high-intensity monochromatic light source.]

[22. The duplex of either of claim 1 or 2, wherein the chromophore or fluorophore is detectable by exposure to a laser.]

[23. The set of duplexes of either of claim 4 or 5, wherein the primers are DNA.]

[24. The set of duplexes of either of claim 4 or 5, wherein the chromophore or fluorophore is detectable by exposure to a high-intensity monochromatic light source.]

[25. The set of duplexes of either of claim 4 or 5, wherein the chromophore or fluorophore is detectable by exposure to a laser.]

[26. The set of reagents of claim 7, wherein the primers are DNA.]

[27. The set of reagents of claim 7, wherein the chromophore or fluorophore is detectable by exposure to a high-intensity monochromatic light source.]

[28. The set of reagents of claim 7, wherein the chromophore or fluorophore is detectable by exposure to a laser.]

[29. The polynucleotide of any of claims 14 to 16, wherein the primer is DNA.]

[30. The polynucleotide of any of claims 14 to 16, wherein the chromophore or fluorophore is detectable by exposure to a high-intensity monochromatic light source.]

[31. The polynucleotide of any of claims 14 to 16, wherein the chromophore or fluorophore is detectable by exposure to a laser.]

[32. The duplex of any of claims 11 to 13, wherein the primer is DNA.]

[33. The duplex of any of claims 11 to 13, wherein the chromophore or fluorophore is detectable by exposure to a high-intensity monochromatic light source.]

[34. The duplex of any of claims 11 to 13, wherein the chromophore or fluorophore is detectable by exposure to a laser.]

[35. The duplex of either of claim 1 or 2, wherein the chromophore or fluorophore is covalently coupled to the primer through an amine linkage.]

[36. The set of duplexes of either of claim 4 or 5, wherein the chromophore or fluorophore is covalently coupled to the primer through an amine linkage.]

[37. The set of reagents of claim 7, wherein the chromophore or fluorophore is covalently coupled to the primer through an amine linkage.]

[38. The duplex of either of claim 1 or 2, wherein the chromophore or fluorophore is covalently coupled to the primer at its 5' end.]

[39. The set of duplexes of either of claim 4 or 5, wherein the chromophore or fluorophore is covalently coupled to the primer at its 5' end.]

[40. The set of reagents of claim 7, wherein the chromophore or fluorophore is covalently coupled to the primer at its 5' end.]

[41. The polynucleotide of claim 3, wherein the chromophore or fluorophore is covalently coupled to the primer through an amine linkage.]

[42. The polynucleotide of claim 3, wherein the chromophore or fluorophore is covalently coupled to the primer at its 5' end.]

[43. The polynucleotide of claim 3, wherein the chromophore or fluorophore is detectable by exposure to a laser.]

[44. The set of polynucleotides of claim 6, wherein the primers are DNA.]

[45. The set of polynucleotides of claim 6, wherein the chromophore or fluorophore is detectable by exposure to a high-intensity monochromatic light source.]

[46. The set of polynucleotides of claim 6, wherein the chromophore or fluorophore is detectable by exposure to a laser.]

[47. The set of polynucleotides of claim 6, wherein the chromophore or fluorophore is covalently coupled to the primer through an amine linkage.]

[48. The set of polynucleotides of claim 6, wherein the chromophore or fluorophore is covalently coupled to the primer at its 5' end.]

[49. A duplex comprising an oligonucleotide primer and a template, wherein the primer hybridizes to a specific region of the template and wherein the primer is covalently coupled to a chromophore or fluorophore so as to allow chain extension by a polymerase.]

[50. A plurality of identical oligonucleotide primers of defined length and base sequences wherein each primer is covalently coupled to a fluorophore or chromophore so as to allow chain extension by a polymerase.]

[51. The plurality of claim 50 wherein said primers have a free 3' hydroxyl group.]

[52. The plurality of claim 51 wherein the chromophore or fluorophore is covalently coupled to the primer at its 5' end.]

[53. The plurality of claim 50 wherein said primers are coupled to said fluorophore or chromophore by an amine linkage.]

[54. A composition comprising the plurality of claim 50.]

[55. The composition of claim 54 further comprising a buffer.]

[56. A set of reagents comprising the plurality of claim 50 and a polymerase.]

[57. A set of reagents comprising two or more pluralities of oligonucleotide primers of claim 50 wherein each plurality has a different emission spectra.]

[58. A plurality of single-stranded labeled polynucleotides produced by the method comprising the steps of hybridizing the plurality of oligonucleotide primers of claim 50 to a template thereby forming a plurality of duplexes; extending the primers of said duplexes by a polymerase thereby forming labeled polynucleotides; and separating said labeled polynucleotides from said duplexes.]

[59. A set of single stranded labeled polynucleotides comprising two or more pluralities of polynucleotides of claim 58, wherein each plurality has a different emission spectra.]

[60. The plurality of claim 50 wherein the chromophore or fluorophore is detectable by exposure to a high-intensity monochromatic light source.]

[61. The plurality of claim 50 wherein the chromophore or fluorophore is detectable by exposure to a laser.]

62. *A method of nucleic acid sequence analysis, comprising extending an oligonucleotide along a complementary strand of DNA of a duplex by a polymerase to produce a labeled extension product, wherein the duplex comprises the oligonucleotide specifically hybridized to the complementary strand of DNA, and wherein the oligonucleotide is covalently coupled to a fluorophore so as to allow chain extension by the polymerase.*

63. *The method of claim 62, further comprising separating said labeled extension product from said duplex.*

64. *A DNA sequencing method, comprising extending oligonucleotides of a set of duplexes along hybridized complementary strands of DNA by a polymerase to produce a set of labeled extension products, wherein the set of labeled extension products comprises two or more extension products, wherein an extension product comprises an extended oligonucleotide specifically hybridized to a complementary strand of DNA, thereby producing four sets of labeled extension products, wherein the extension products of each set are distinguishably labeled with a different type of fluorophore from the extension products of the other sets.*

65. *The method of claim 64 or claim 62, wherein the fluorophore is covalently coupled to the oligonucleotide through an amine linkage.*

66. *A mixture comprising a polymerase and a duplex, wherein the duplex comprises an oligonucleotide specifically hybridized to a complementary strand of DNA, wherein the oligonucleotide is covalently coupled to a fluorophore so as to allow chain extension by the polymerase.*

67. *A composition comprising four sets of oligonucleotides, wherein oligonucleotides of each of the four sets are distinguishably labeled with a different type of fluorophore from the oligonucleotides of the other three sets.*

68. *The method of claim 64, wherein the extension products comprise a terminal nucleotide having any one of four different types of terminal base components, wherein substantially all molecules of the same set of labeled extension products have the same type of terminal base component, and substantially all molecules of different sets of labeled extension products have different types of terminal base components.*

69. *The composition of claim 67, wherein the oligonucleotides comprise a terminal nucleotide having any one of four different types of terminal base components, wherein substantially all oligonucleotide molecules of the same set have the*

same type of terminal base component, and substantially all oligonucleotide molecules of different sets have different types of terminal base components.

70. The method of claim 62, wherein substantially all molecules of the labeled extension product individually comprise a single fluorescent nucleotide.

71. The method of claim 64, wherein substantially all molecules of the labeled extension products individually comprise a single fluorescent nucleotide.

72. The mixture of claim 66, wherein substantially all oligonucleotide molecules individually comprise a single fluorescent nucleotide.

73. The composition of claim 67, wherein substantially all oligonucleotide molecules of each set individually comprise a single fluorescent nucleotide.

74. The method of claim 62, wherein substantially all molecules of the labeled extension product are individually coupled to a fluorophore by a single covalent linkage.

75. The method of claim 64, wherein substantially all molecules of the labeled extension products are individually coupled to a fluorophore by a single covalent linkage.

76. The mixture of claim 66, wherein substantially all oligonucleotide molecules are individually coupled to a fluorophore by a single covalent linkage.

77. The composition of claim 67, wherein substantially all oligonucleotide molecules of each set are individually coupled to a fluorophore by a single covalent linkage.

78. The method of claim 68, wherein substantially all molecules of the labeled extension products individually comprise a single fluorescent nucleotide.

79. The composition of claim 69, wherein substantially all oligonucleotide molecules of each set individually comprise a single fluorescent nucleotide.

80. The method of claim 74, wherein substantially all molecules of the labeled extension product individually are terminally labeled with a fluorophore.

81. The method of claim 75, wherein substantially all molecules of the labeled extension products individually are terminally labeled with a fluorophore.

82. The mixture of claim 76, wherein substantially all oligonucleotide molecules individually are terminally labeled with a fluorophore.

83. The composition of claim 77, wherein substantially all oligonucleotide molecules of each set individually are terminally labeled with a fluorophore.

84. The method of claim 68, wherein substantially all molecules of the labeled extension products individually are terminally labeled with a fluorophore.

85. The composition of claim 69, wherein substantially all oligonucleotide molecules of each set individually are terminally labeled with a fluorophore.

86. The method of claim 70, wherein substantially all molecules of the labeled extension product individually are terminally labeled with a fluorophore.

87. The method of claim 71, wherein substantially all molecules of the labeled extension products individually are terminally labeled with a fluorophore.

88. The mixture of claim 72, wherein substantially all oligonucleotide molecules individually are terminally labeled with a fluorophore.

89. The composition of claim 73, wherein substantially all oligonucleotide molecules of each set individually are terminally labeled with a fluorophore.

90. The method of claim 78, wherein substantially all molecules of the labeled extension products individually are terminally labeled with a fluorophore.

91. The composition of claim 79, wherein substantially all oligonucleotide molecules of each set individually are terminally labeled with a fluorophore.

92. The method of claim 74, wherein substantially all molecules of the labeled extension product individually comprise a 5' terminal fluorescent nucleotide.

93. The method of claim 75, wherein substantially all molecules of the labeled extension products individually comprise a 5' terminal fluorescent nucleotide.

94. The mixture of claim 76, wherein substantially all oligonucleotide molecules individually comprise a 5' terminal fluorescent nucleotide.

95. The composition of claim 77, wherein substantially all oligonucleotide molecules of each set individually comprise a 5' terminal fluorescent nucleotide.

96. The method of claim 84, wherein substantially all molecules of the labeled extension products individually comprise a 5' terminal fluorescent nucleotide.

97. The composition of claim 85, wherein substantially all oligonucleotide molecules of each set individually comprise a 5' terminal fluorescent nucleotide.

98. The method of claim 86, wherein substantially all molecules of the labeled extension product individually comprise a 5' terminal fluorescent nucleotide.

99. The method of claim 87, wherein substantially all molecules of the labeled extension products individually comprise a 5' terminal fluorescent nucleotide.

100. The mixture of claim 88, wherein substantially all oligonucleotide molecules individually comprise a 5' terminal fluorescent nucleotide.

101. The composition of claim 89, wherein substantially all oligonucleotide molecules of each set individually comprise a 5' terminal fluorescent nucleotide.

102. The method of claim 90, wherein substantially all molecules of the labeled extension products individually comprise a 5' terminal fluorescent nucleotide.

103. The composition of claim 91, wherein substantially all oligonucleotide molecules of each set individually comprise a 5' terminal fluorescent nucleotide.

104. The composition of claim 69, wherein substantially all oligonucleotide molecules of each set individually comprise a 3' terminal fluorescent nucleotide.

105. The composition of claim 73, wherein substantially all oligonucleotide molecules of each set individually comprise a 3' terminal fluorescent nucleotide.

106. The composition of claim 79, wherein substantially all oligonucleotide molecules of each set individually comprise a 3' terminal fluorescent nucleotide.

107. The method of claim 68, wherein substantially all molecules of the labeled extension products individually comprise a 3' terminal nucleotide that is complementary to a corresponding nucleotide on the complementary strand of DNA.

108. The composition of claim 69, wherein substantially all oligonucleotide molecules of each set individually (i) are specifically hybridized to a complementary strand of DNA, and (ii) comprise a 3' terminal nucleotide that is complementary to a corresponding nucleotide on the complementary strand of DNA.

109. The method of claim 71, wherein substantially all molecules of the labeled extension products individually comprise a 3' terminal nucleotide that is complementary to a corresponding nucleotide on the complementary strand of DNA.

110. The composition of claim 73, wherein substantially all oligonucleotide molecules of each set individually (i) are specifically hybridized to a complementary strand of DNA,

and (ii) comprise a 3' terminal nucleotide that is complementary to a corresponding nucleotide on the complementary strand of DNA.

111. The method of claim 75, wherein substantially all molecules of the labeled extension products individually comprise a 3' terminal nucleotide that is complementary to a corresponding nucleotide on the complementary strand of DNA.

112. The composition of claim 77, wherein substantially all oligonucleotide molecules of each set individually (i) are specifically hybridized to a complementary strand of DNA, and (ii) comprise a 3' terminal nucleotide that is complementary to a corresponding nucleotide on the complementary strand of DNA.

113. The composition of claim 79, wherein substantially all oligonucleotide molecules of each set individually comprise a 3' terminal nucleotide that is complementary to a corresponding nucleotide in a complementary strand of DNA.

114. The method of claim 81, wherein substantially all molecules of the labeled extension products individually comprise a 3' terminal nucleotide that is complementary to a corresponding nucleotide on the complementary strand of DNA.

115. The composition of claim 83, wherein substantially all oligonucleotide molecules of each set individually (i) are specifically hybridized to a complementary strand of DNA, and (ii) comprise a 3' terminal nucleotide that is complementary to a corresponding nucleotide on the complementary strand of DNA.

116. The method of claim 68, wherein substantially all molecules of the labeled extension products individually comprise a 3' terminal nucleotide that is adapted to terminate polymerase extension.

117. The composition of claim 69, wherein substantially all oligonucleotide molecules of each set individually comprise a 3' terminal nucleotide that is adapted to terminate polymerase extension.

118. The method of claim 70, wherein substantially all molecules of the labeled extension product individually comprise a 3' terminal nucleotide that is adapted to terminate polymerase extension.

119. The method of claim 71, wherein substantially all molecules of the labeled extension products individually comprise a 3' terminal nucleotide that is adapted to terminate polymerase extension.

120. The composition of claim 73, wherein substantially all oligonucleotide molecules of each set individually comprise a 3' terminal nucleotide that is adapted to terminate polymerase extension.

121. The method of claim 74, wherein substantially all molecules of the labeled extension product individually comprise a 3' terminal nucleotide that is adapted to terminate polymerase extension.

122. The method of claim 75, wherein substantially all molecules of the labeled extension products individually comprise a 3' terminal nucleotide that is adapted to terminate polymerase extension.

123. The composition of claim 77, wherein substantially all oligonucleotide molecules of each set individually comprise a 3' terminal nucleotide that is adapted to terminate polymerase extension.

124. The method of claim 78, wherein substantially all molecules of the labeled extension products individually comprise a 3' terminal nucleotide that is adapted to terminate polymerase extension.

125. The composition of claim 79, wherein substantially all oligonucleotide molecules of each set individually comprise a 3' terminal nucleotide that is adapted to terminate polymerase extension.

126. The method of claim 80, wherein substantially all molecules of the labeled extension product individually comprise a 3' terminal nucleotide that is adapted to terminate polymerase extension.

127. The method of claim 81, wherein substantially all molecules of the labeled extension products individually comprise a 3' terminal nucleotide that is adapted to terminate polymerase extension.

128. The composition of claim 83, wherein substantially all oligonucleotide molecules of each set individually comprise a 3' terminal nucleotide that is adapted to terminate polymerase extension.

129. The composition of claim 69, further comprising a polymerase or nucleotides adapted to terminate polymerase extension.

130. The composition of claim 73, further comprising a polymerase or nucleotides adapted to terminate polymerase extension.

131. The composition of claim 77, further comprising a polymerase or nucleotides adapted to terminate polymerase extension.

132. The composition of claim 79, further comprising a polymerase or nucleotides adapted to terminate polymerase extension.

133. The composition of claim 83, further comprising a polymerase or nucleotides adapted to terminate polymerase extension.

134. The composition of claim 85, further comprising a polymerase or nucleotides adapted to terminate polymerase extension.

135. The composition of claim 89, further comprising a polymerase or nucleotides adapted to terminate polymerase extension.

136. The composition of claim 91, further comprising a polymerase or nucleotides adapted to terminate polymerase extension.

137. The method of claim 68, wherein the four different types of terminal base components are adenosine, guanosine, thymidine and cytosine.

138. The composition of claim 69, wherein the four different types of terminal base components are adenosine, guanosine, thymidine and cytosine.

139. The method of claim 81, wherein the oligonucleotides are fluorescently labeled before being extended.

140. The method of claim 84, wherein the oligonucleotides are fluorescently labeled before being extended.

141. The method of claim 87, wherein the oligonucleotides are fluorescently labeled before being extended.

142. The method of claim 90, wherein the oligonucleotides are fluorescently labeled before being extended.

143. A method of nucleic acid sequence analysis, comprising producing the composition of claim 69, and detecting the type of fluorophore on oligonucleotides of the composition.

144. A method of nucleic acid sequence analysis, comprising producing the composition of claim 73, and detecting the type of fluorophore on oligonucleotides of the composition.

145. A method of nucleic acid sequence analysis, comprising producing the composition of claim 77, and detecting the type of fluorophore on oligonucleotides of the composition.

146. A method of nucleic acid sequence analysis, comprising producing the composition of claim 83, and detecting the type of fluorophore on oligonucleotides of the composition.

147. A method of nucleic acid sequence analysis, comprising producing the composition of claim 85, and detecting the type of fluorophore on oligonucleotides of the composition.

148. A method of nucleic acid sequence analysis, comprising producing the composition of claim 104, and detecting the type of fluorophore on oligonucleotides of the composition.

149. A method of nucleic acid sequence analysis, comprising producing the composition of claim 105, and detecting the type of fluorophore on oligonucleotides of the composition.

150. A method of nucleic acid sequence analysis, comprising producing the composition of claim 108, and detecting the type of fluorophore on oligonucleotides of the composition.

151. A method of nucleic acid sequence analysis, comprising producing the composition of claim 117, and detecting the type of fluorophore on oligonucleotides of the composition.

152. The method of claim 68, wherein the oligonucleotides are fluorescently labeled before being extended.

153. The method of claim 71, wherein the oligonucleotides are fluorescently labeled before being extended.

154. The method of claim 75, wherein the oligonucleotides are fluorescently labeled before being extended.

155. The method of claim 78, wherein the oligonucleotides are fluorescently labeled before being extended.

156. The method of claim 93, wherein the oligonucleotides are fluorescently labeled before being extended.

157. The method of claim 107, wherein the oligonucleotides are fluorescently labeled before being extended.

158. The method of claim 116, wherein the oligonucleotides are fluorescently labeled before being extended.

\* \* \* \* \*