



US00RE42670E

(19) **United States**
(12) **Reissued Patent**
Park et al.

(10) **Patent Number:** **US RE42,670 E**
(45) **Date of Reissued Patent:** **Sep. 6, 2011**

(54) **THIN FILM TRANSISTOR ARRAY
SUBSTRATE FOR A LIQUID CRYSTAL
DISPLAY**

(75) Inventors: **Woon-Yong Park**, Kyungki-do (KR);
Jong-Soo Yoon, Choongcheongnam-do
(KR); **Chang-Oh Jeong**, Kyungki-do
(KR)

(73) Assignee: **Samsung Electronics Co., Ltd.**,
Suwon-Si (KR)

(*) Notice: This patent is subject to a terminal dis-
claimer.

(21) Appl. No.: **11/827,989**

(22) Filed: **Jul. 13, 2007**

Related U.S. Patent Documents

Reissue of:

(64) Patent No.: **6,380,559**
Issued: **Apr. 30, 2002**
Appl. No.: **09/585,427**
Filed: **Jun. 2, 2000**

U.S. Applications:

(63) Continuation of application No. 10/749,153, filed on
Dec. 31, 2003, now Pat. No. Re. 40,162.

(30) **Foreign Application Priority Data**

Jun. 3, 1999 (KR) 99-20515
Jul. 6, 1999 (KR) 99-27140
Jul. 8, 1999 (KR) 99-27548
Jul. 22, 1999 (KR) 99-29796

(51) **Int. Cl.**
H01L 29/04 (2006.01)

(52) **U.S. Cl.** **257/59; 257/72; 257/E27.131;**
349/106; 349/143; 349/158

(58) **Field of Classification Search** **257/59,**
257/72, E27.131; 349/106, 139, 143, 158
See application file for complete search history.

(56) **References Cited**

U.S. PATENT DOCUMENTS

6,057,896 A * 5/2000 Rho et al. 349/42
6,087,678 A * 7/2000 Kim 257/59
RE40,162 E * 3/2008 Park et al. 257/59

FOREIGN PATENT DOCUMENTS

JP 09-127707 5/1997
JP 10-163174 6/1998
JP 2000-066240 3/2000
JP 2000-206571 7/2000

* cited by examiner

Primary Examiner — Minh-Loan T Tran

(74) *Attorney, Agent, or Firm* — F. Chau & Associates, LLC.

(57) **ABSTRACT**

A thin film transistor substrate for a liquid crystal display includes an insulating substrate, and a gate line assembly formed on the substrate. The gate line assembly has a double-layered structure with a lower layer exhibiting good contact characteristics with respect to indium tin oxide, and an upper layer exhibiting low resistance characteristics. A gate insulating layer, a semiconductor layer, a contact layer, and first and second data line layers are sequentially deposited onto the substrate with the gate line assembly. The first and second data line layers are patterned to form a data line assembly, and the contact layer is etched through the pattern of the data line assembly such that the contact layer has the same pattern as the data line assembly. A passivation layer is deposited onto the data line assembly, and a photoresist pattern is formed on the passivation layer by using a mask of different light transmissivities mainly at a display area and a peripheral area. The passivation layer and the underlying layers are etched through the photoresist pattern to form a semiconductor pattern and contact windows. A pixel electrode, a supplemental gate pad and a supplemental data pad are then formed of indium tin oxide or indium zinc oxide. The gate and data line assemblies may be formed with a single layered structure. A black matrix and a color filter may be formed at the structured substrate before forming the pixel electrode, and an opening portion may be formed between the pixel electrode and the data line to prevent possible short circuits.

4 Claims, 74 Drawing Sheets

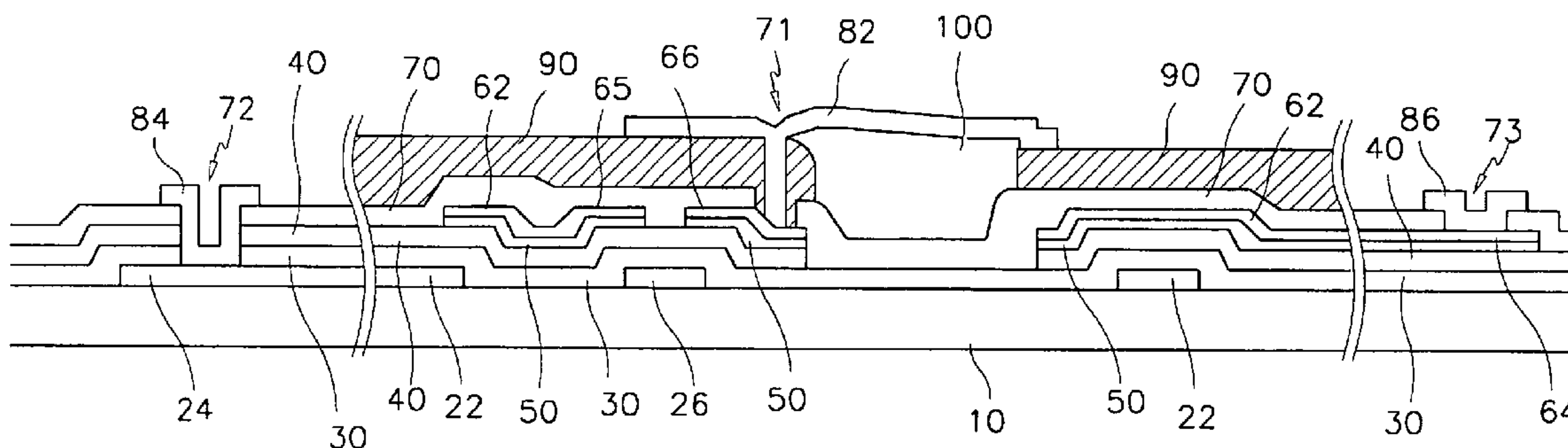

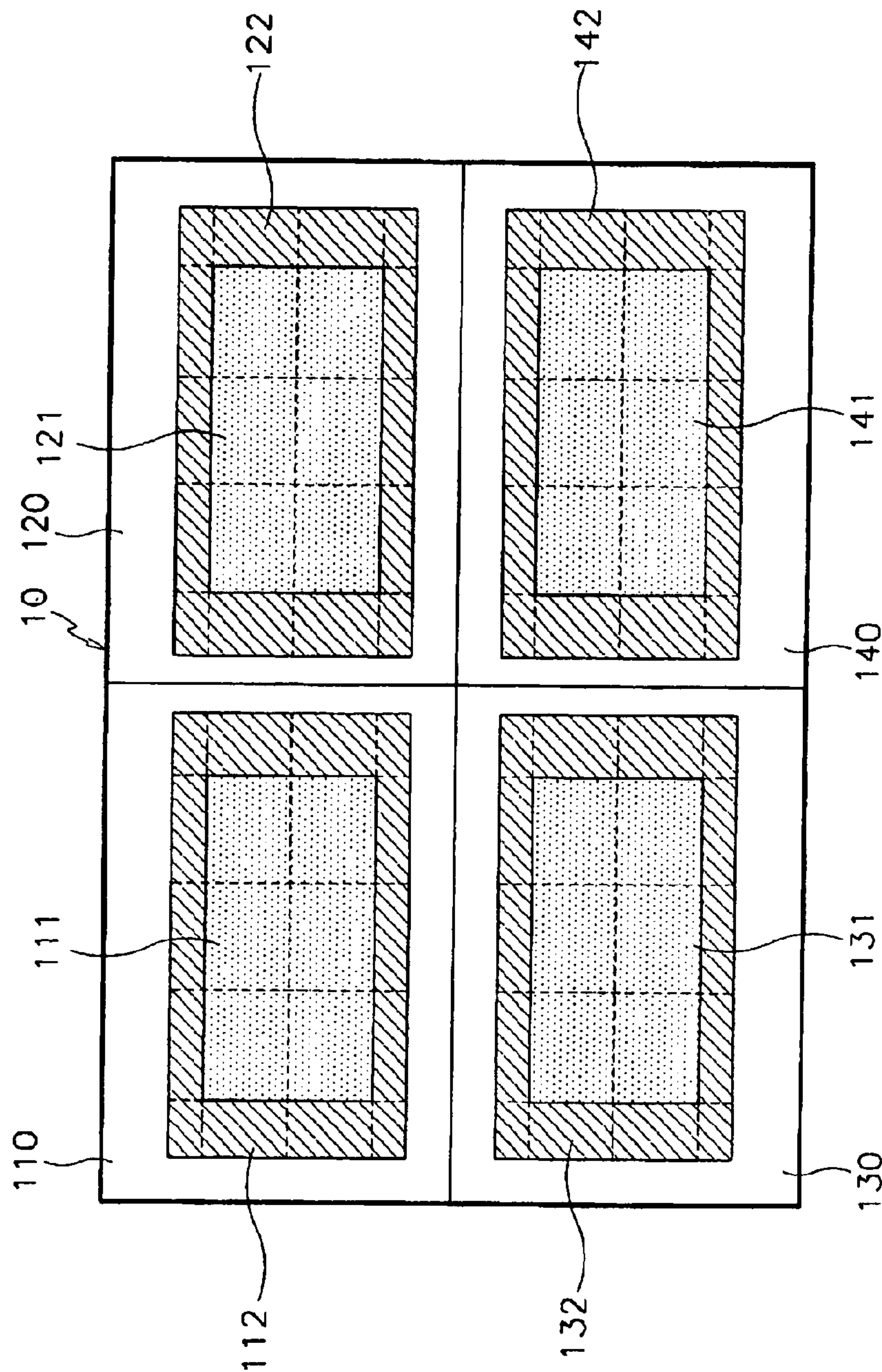

FIG. 1

FIG. 2

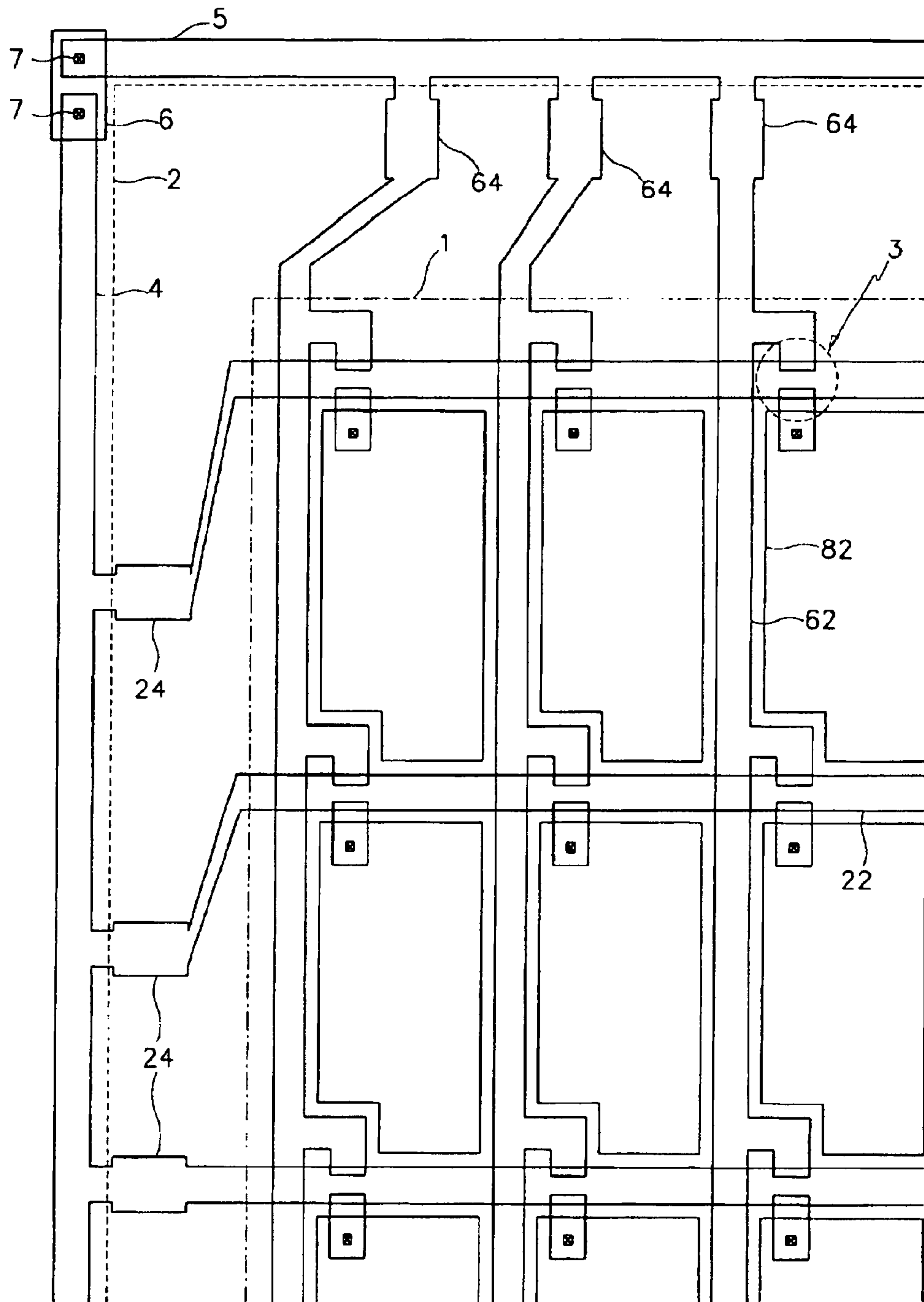

FIG. 3

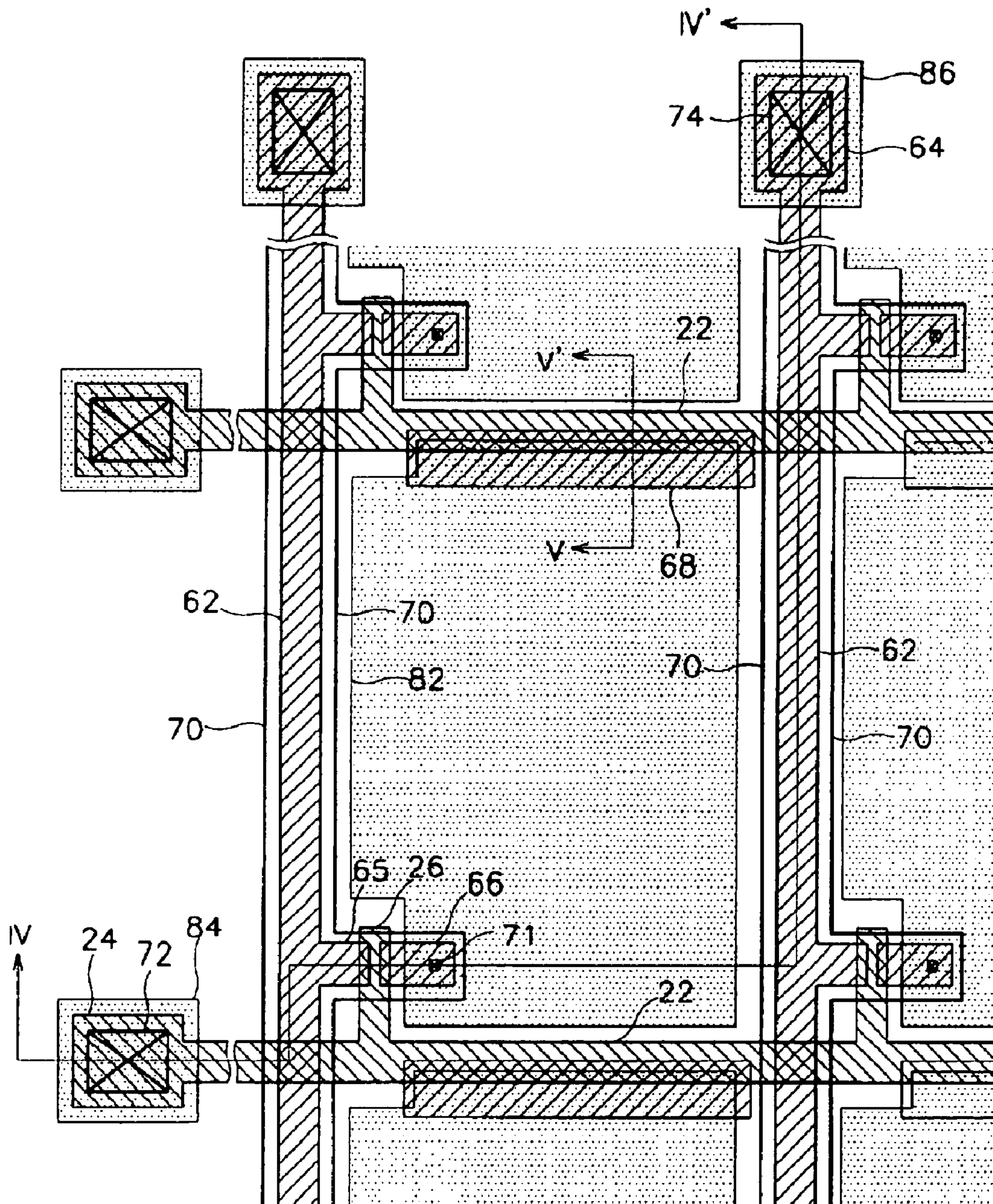

FIG. 4

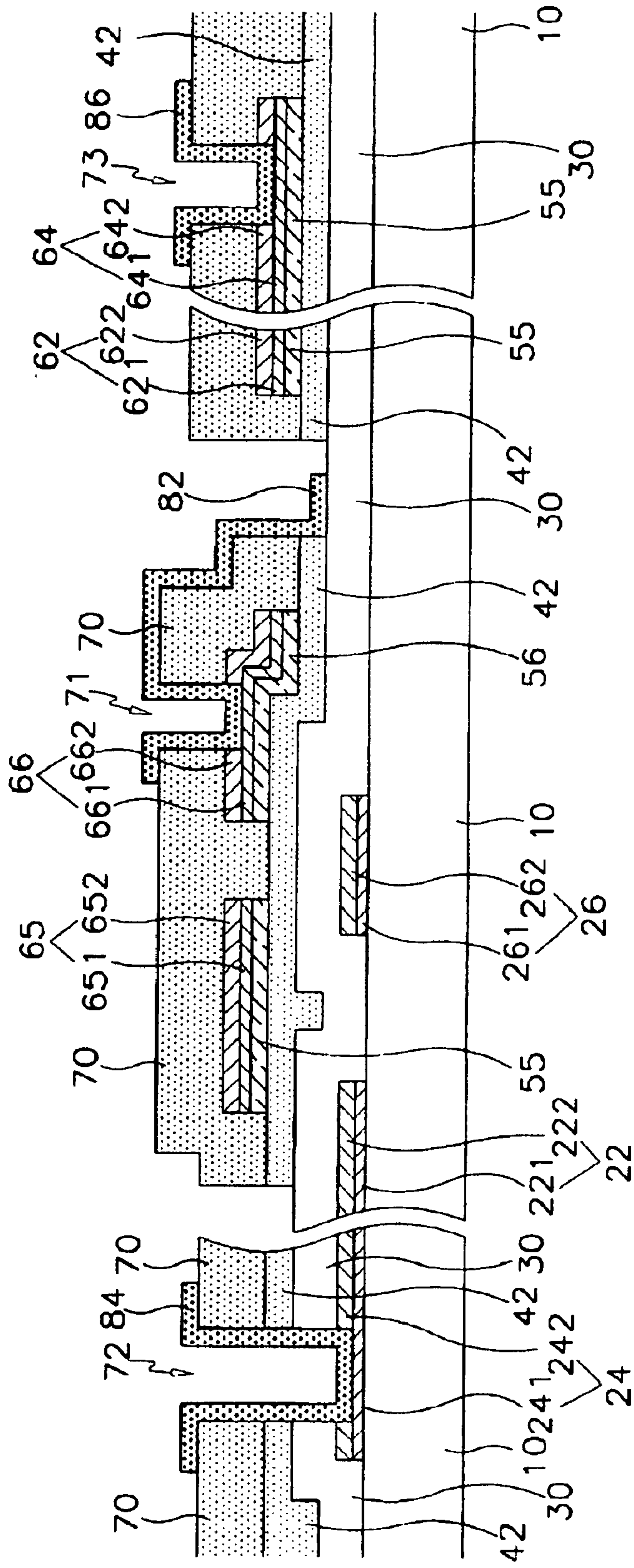

FIG. 5

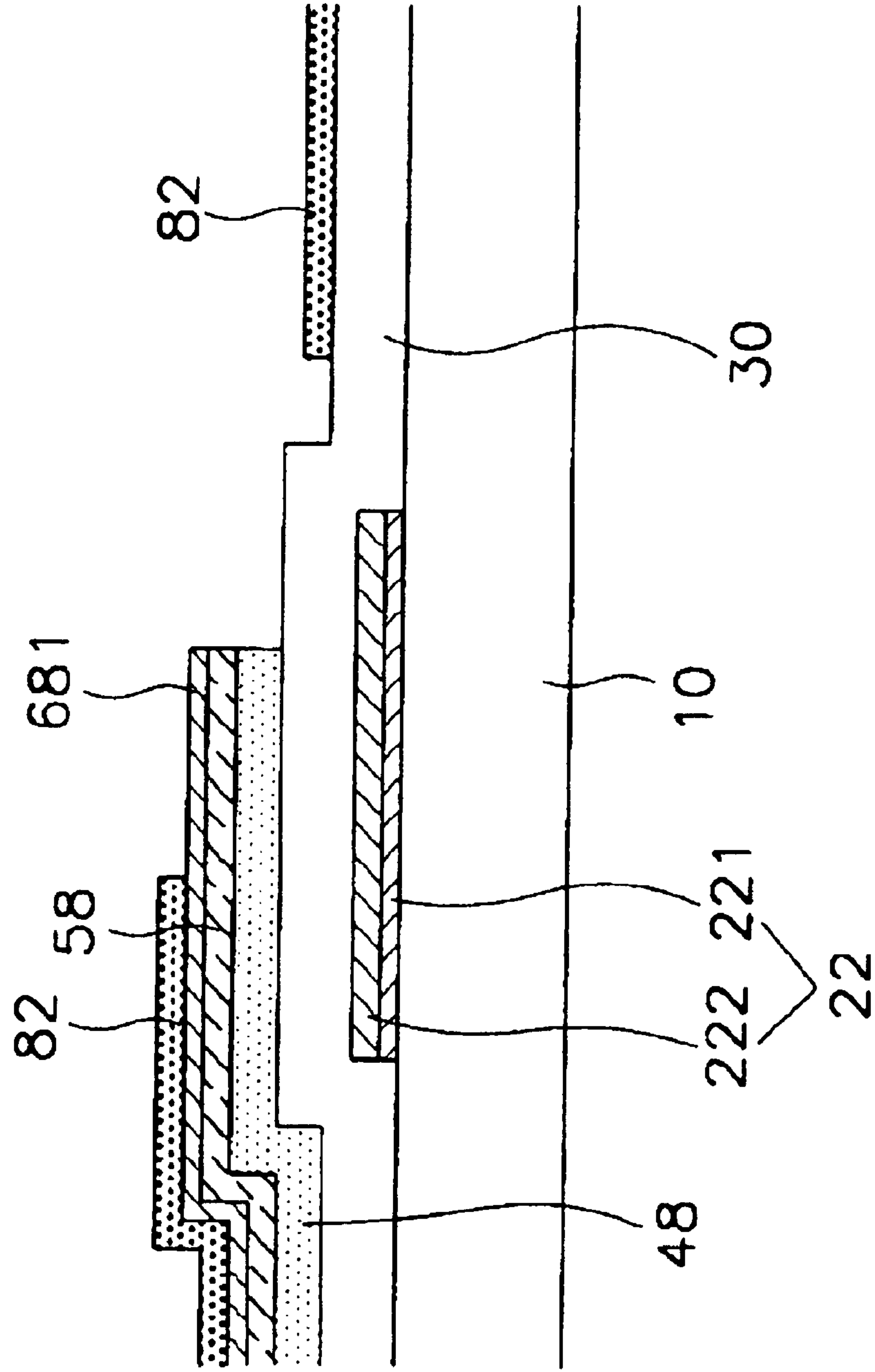

FIG. 6A

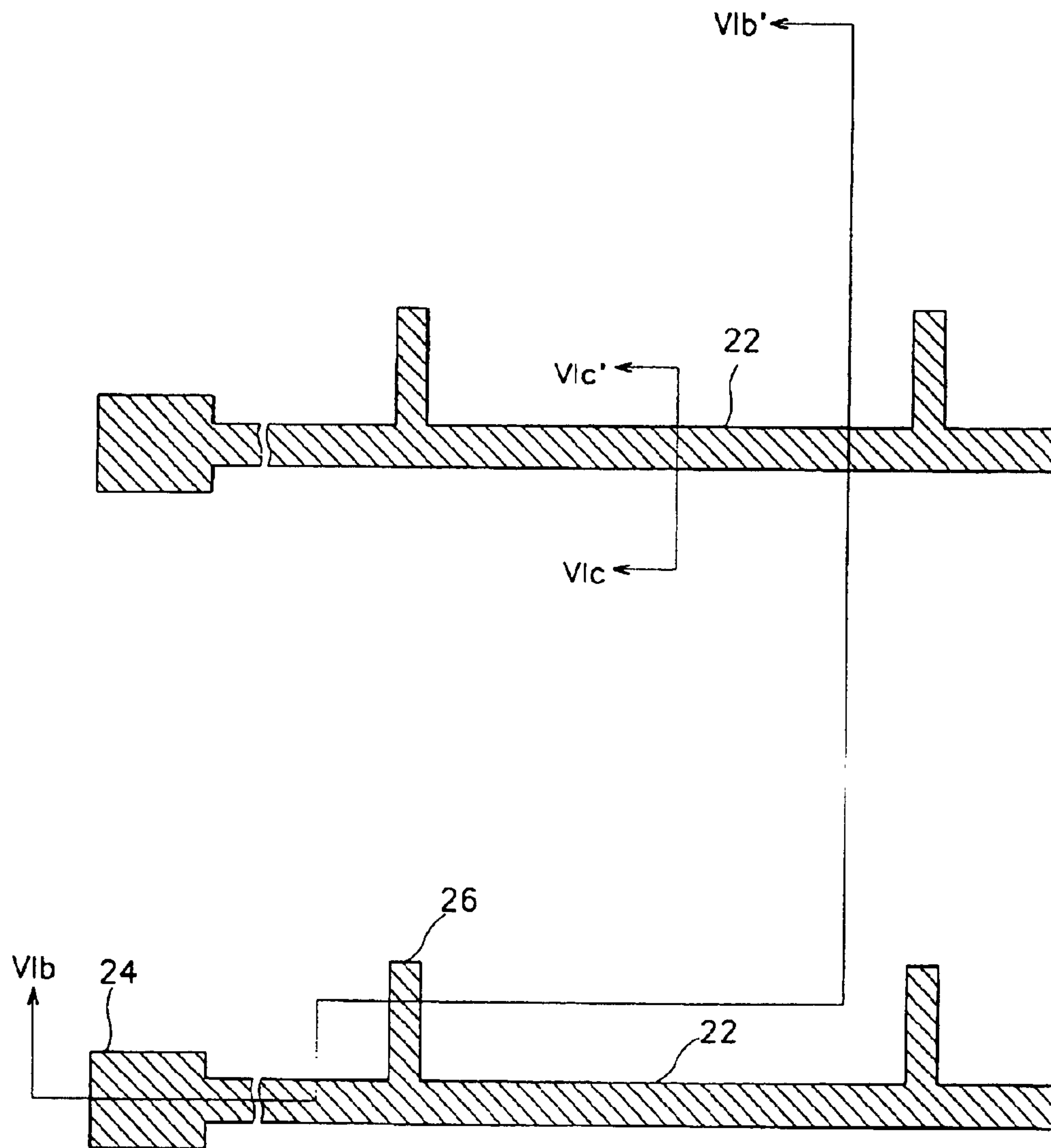

FIG. 6B

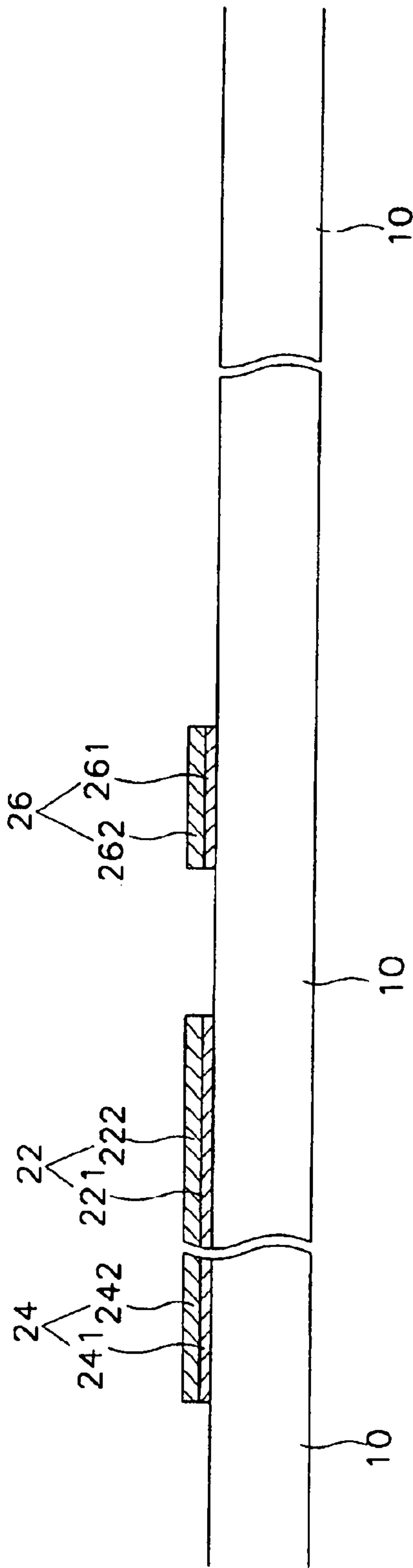

FIG. 6C

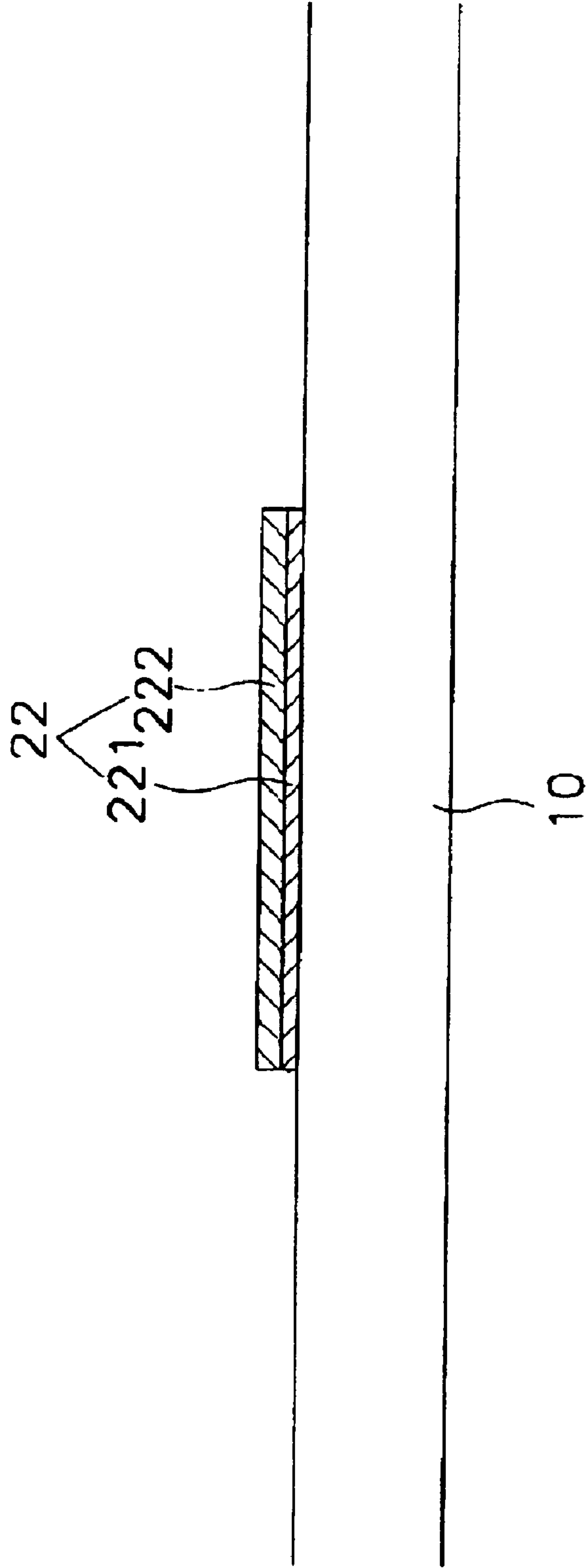

FIG. 7A

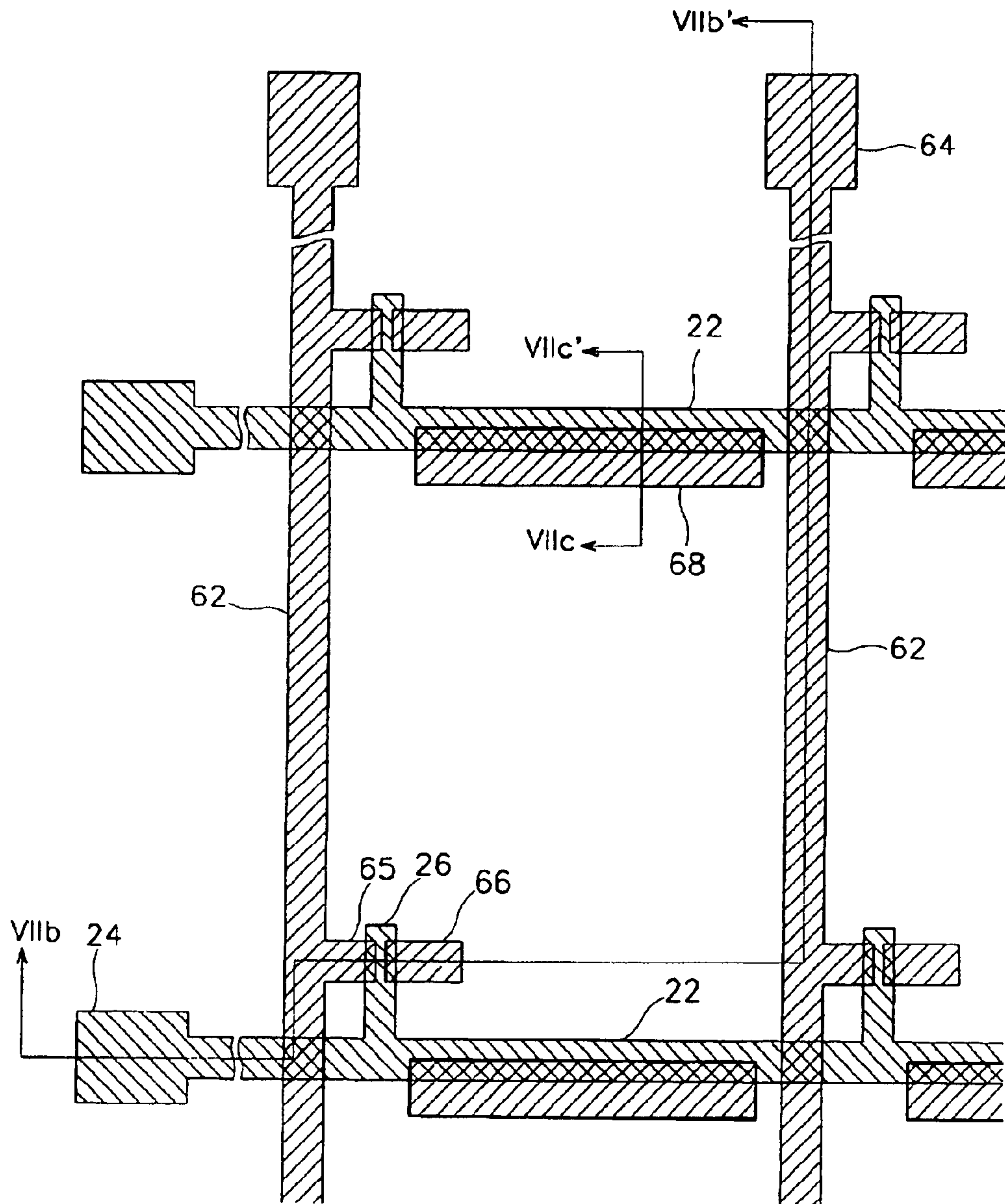

FIG. 7B

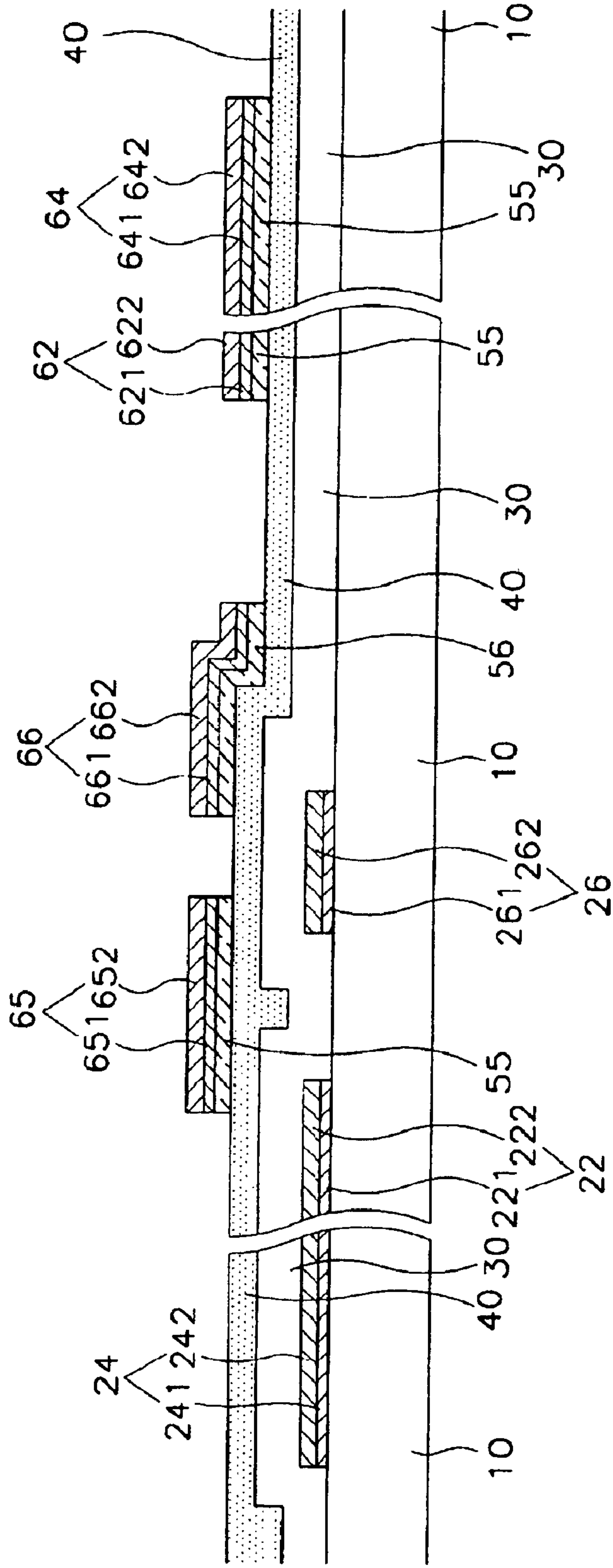

FIG. 7C

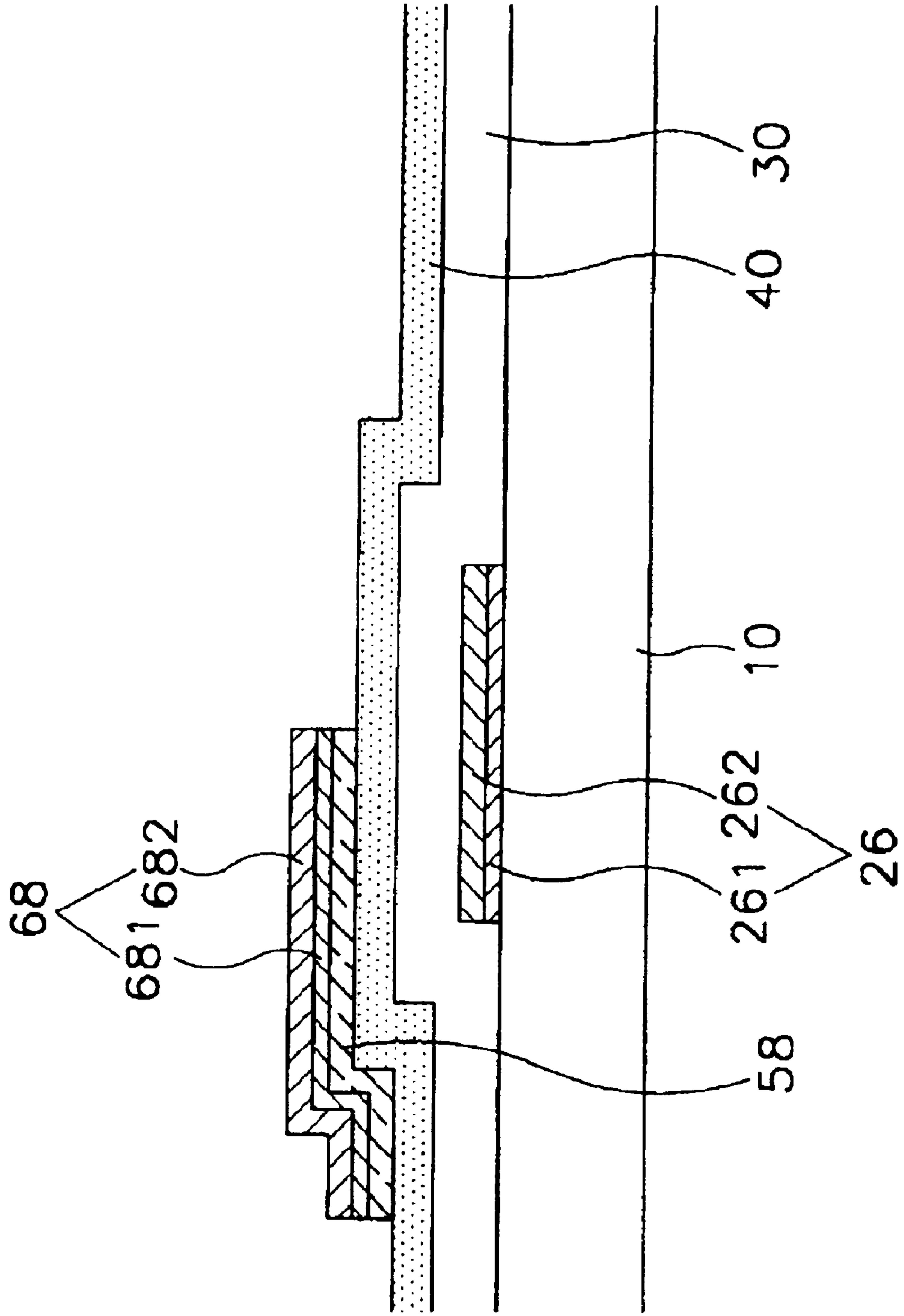

FIG. 8A

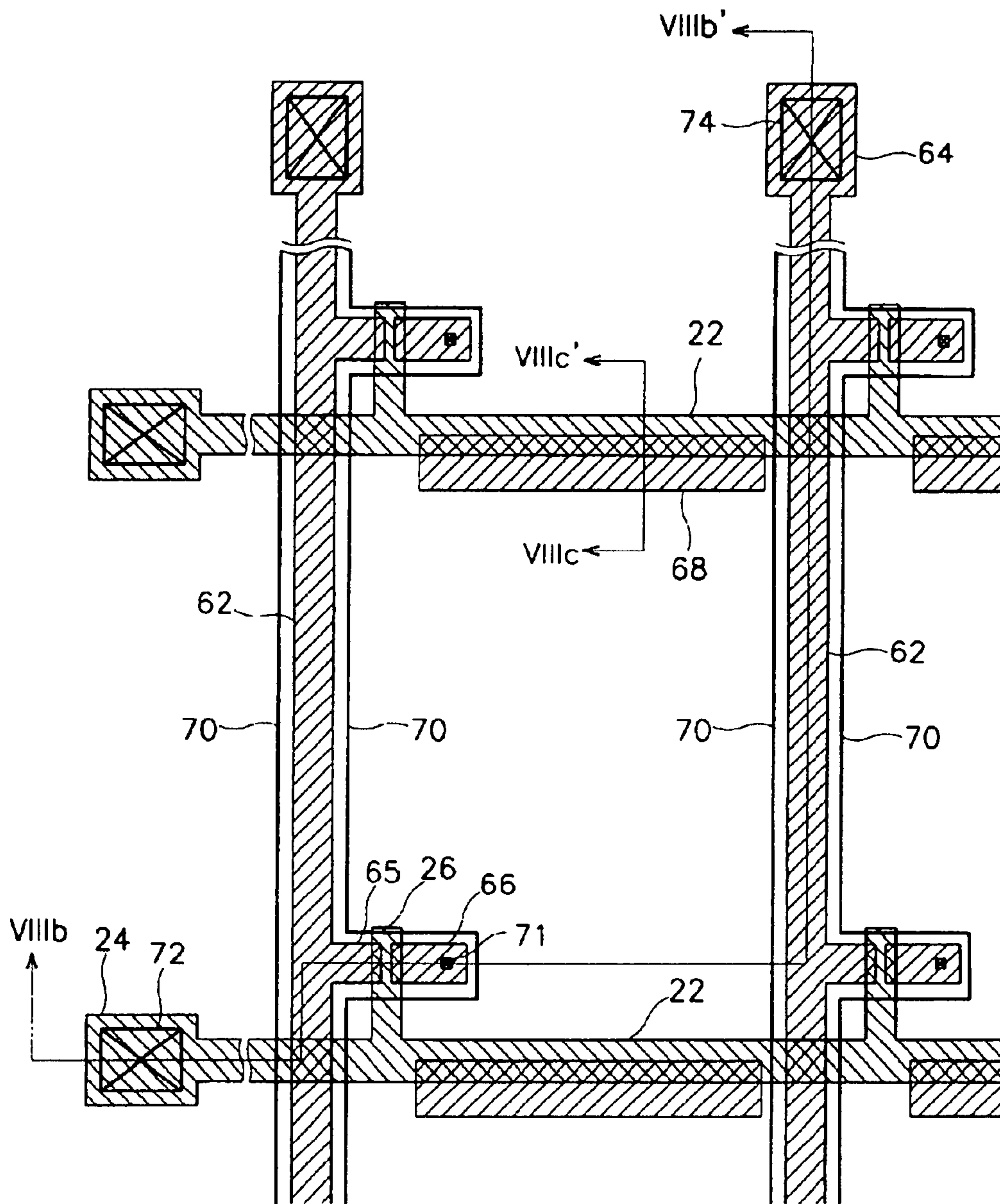

FIG. 8B

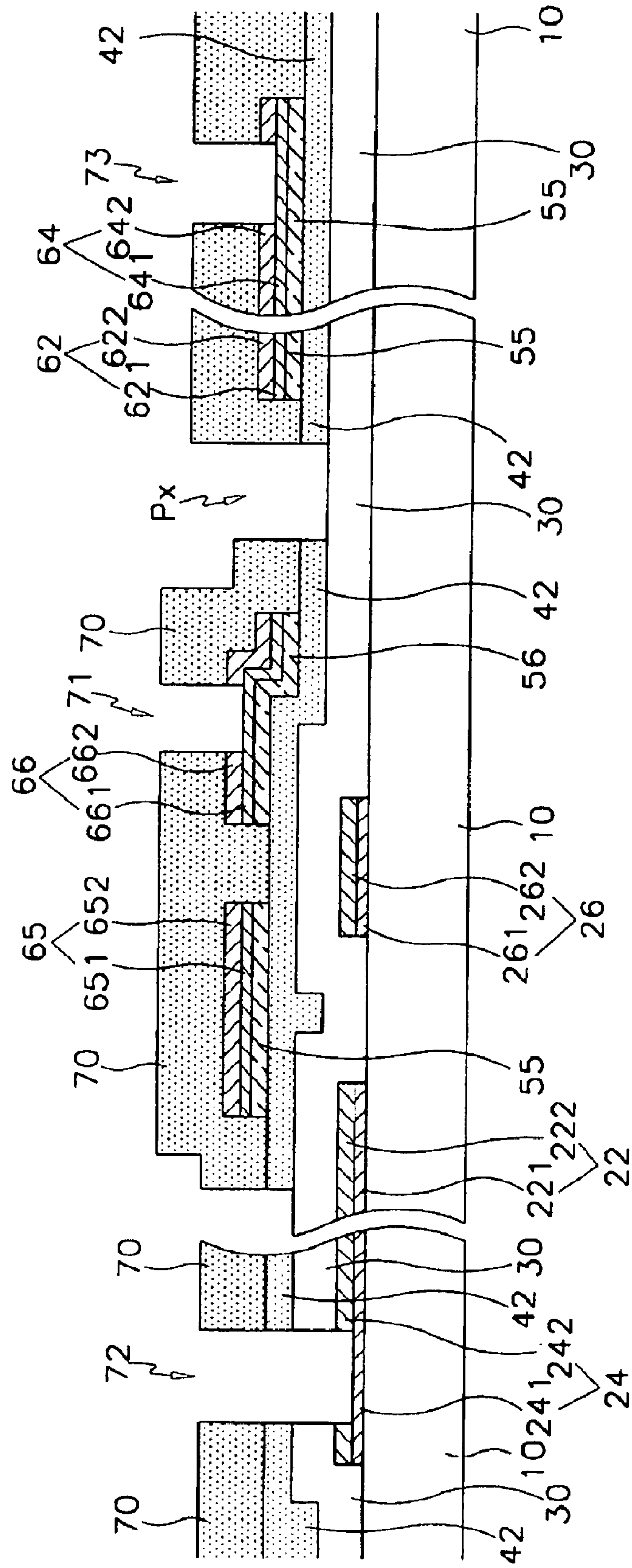

FIG. 8C

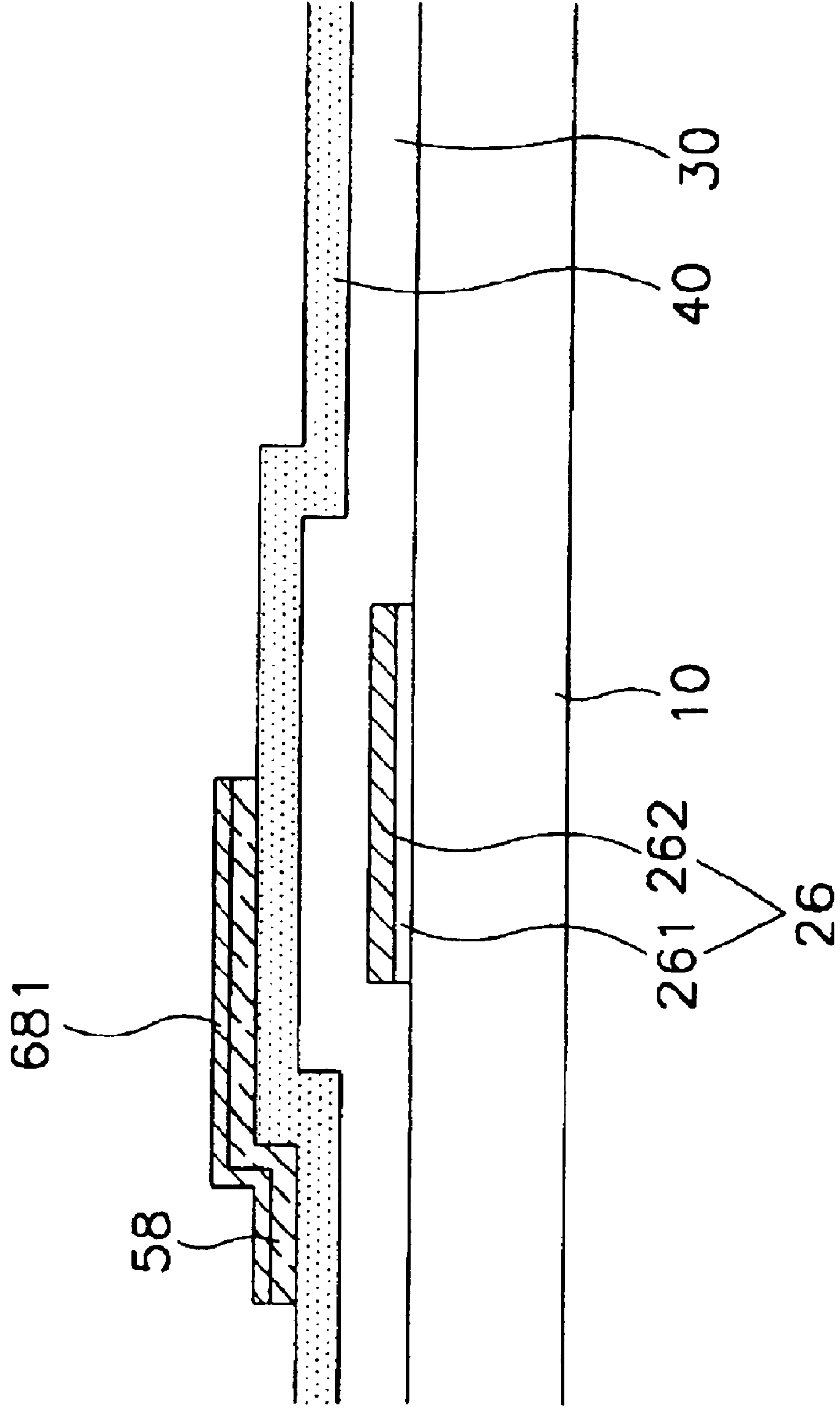

FIG. 9A

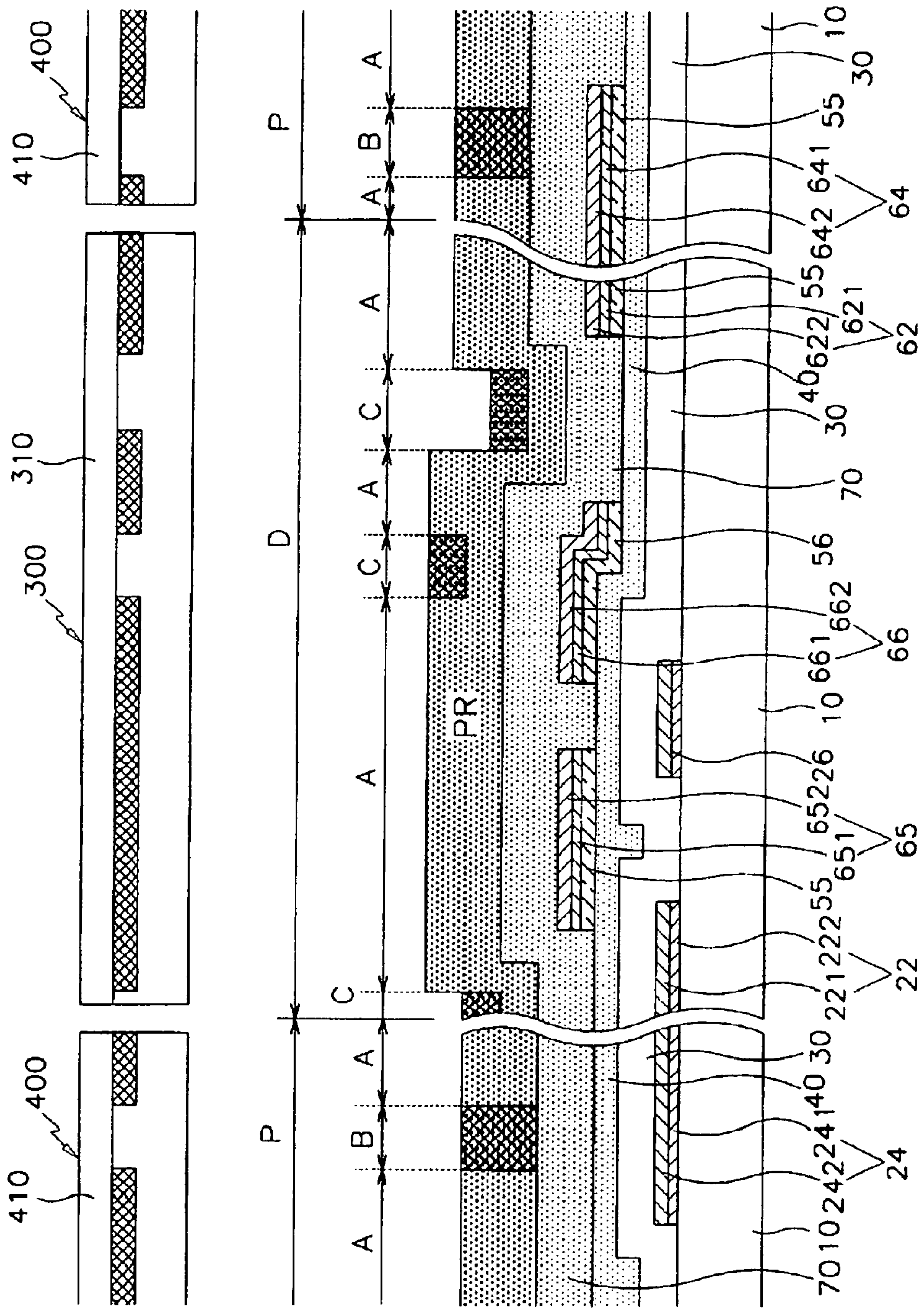

FIG. 9B

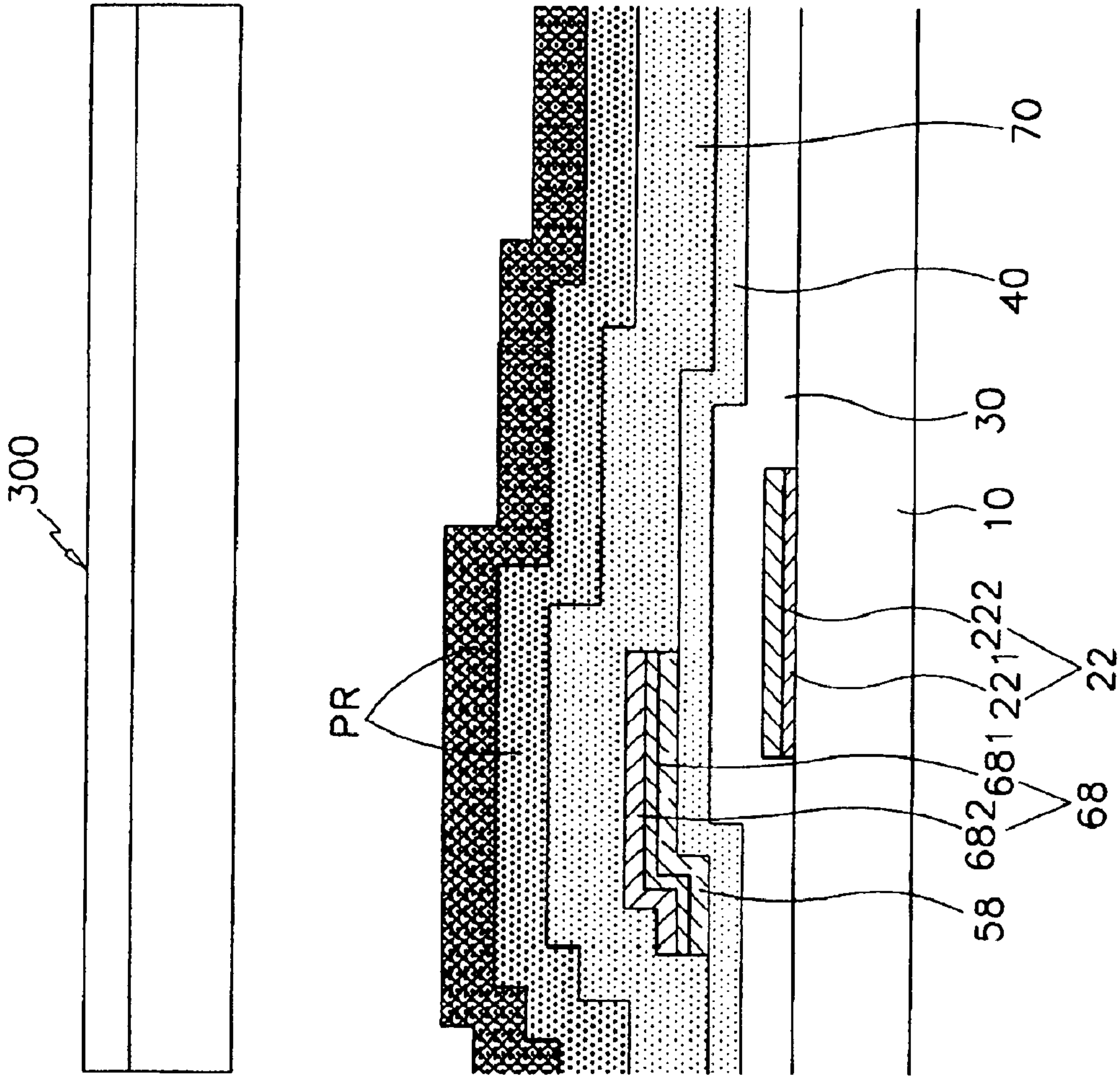

FIG. 10A

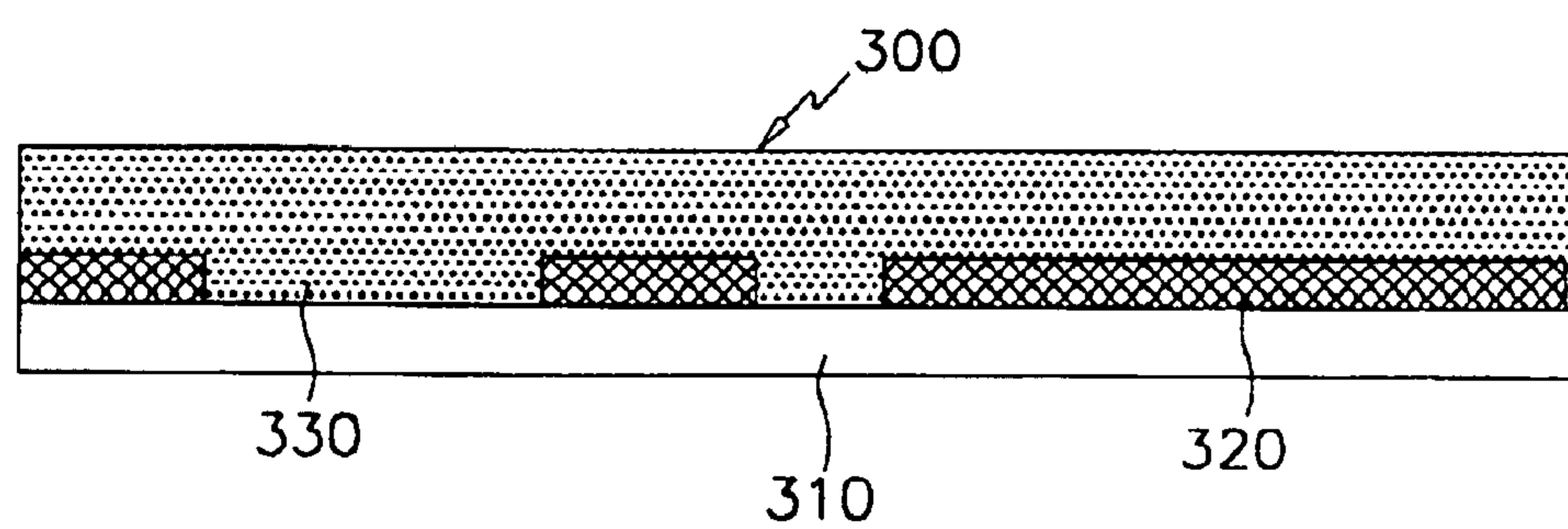

FIG. 10B

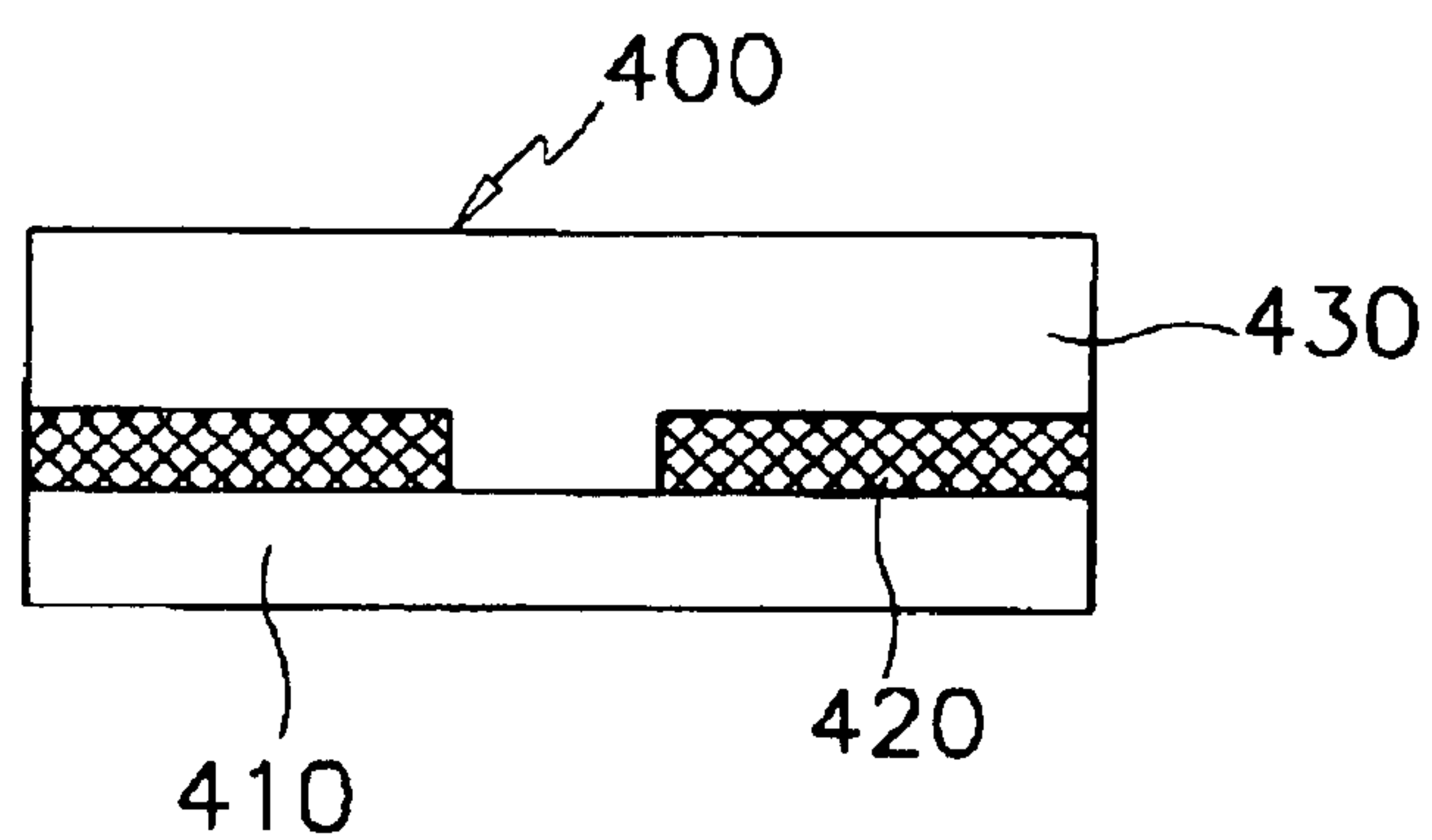

FIG. 11A

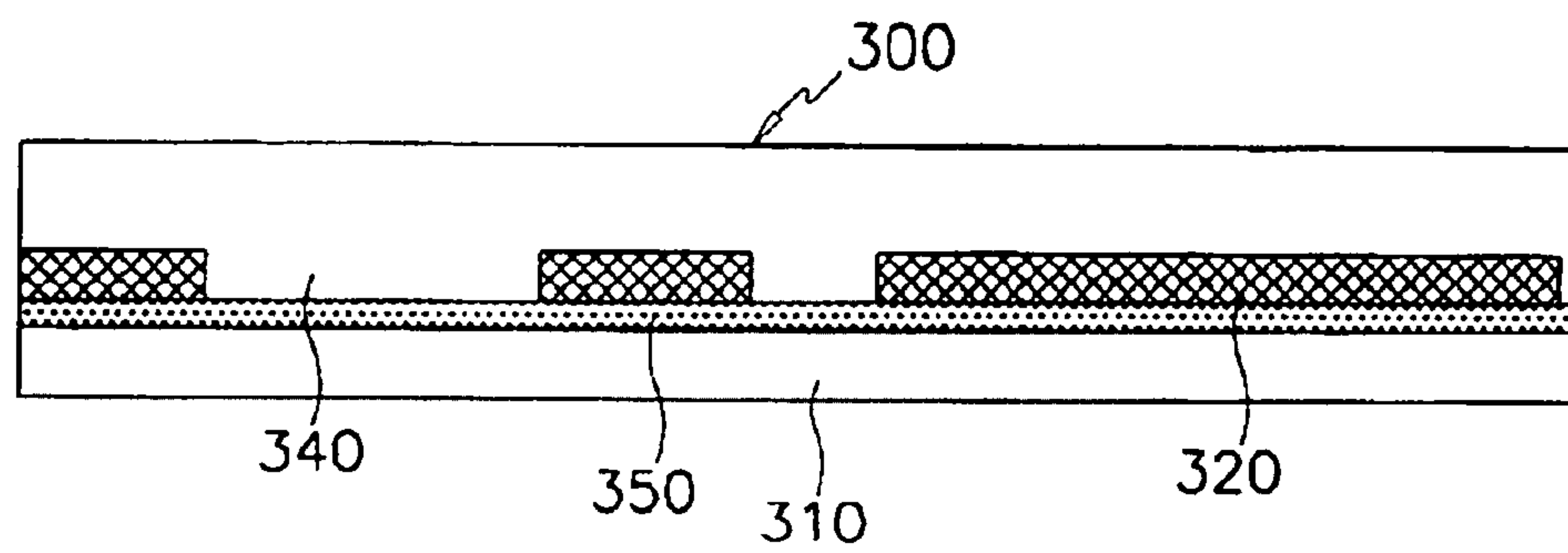

FIG. 11B

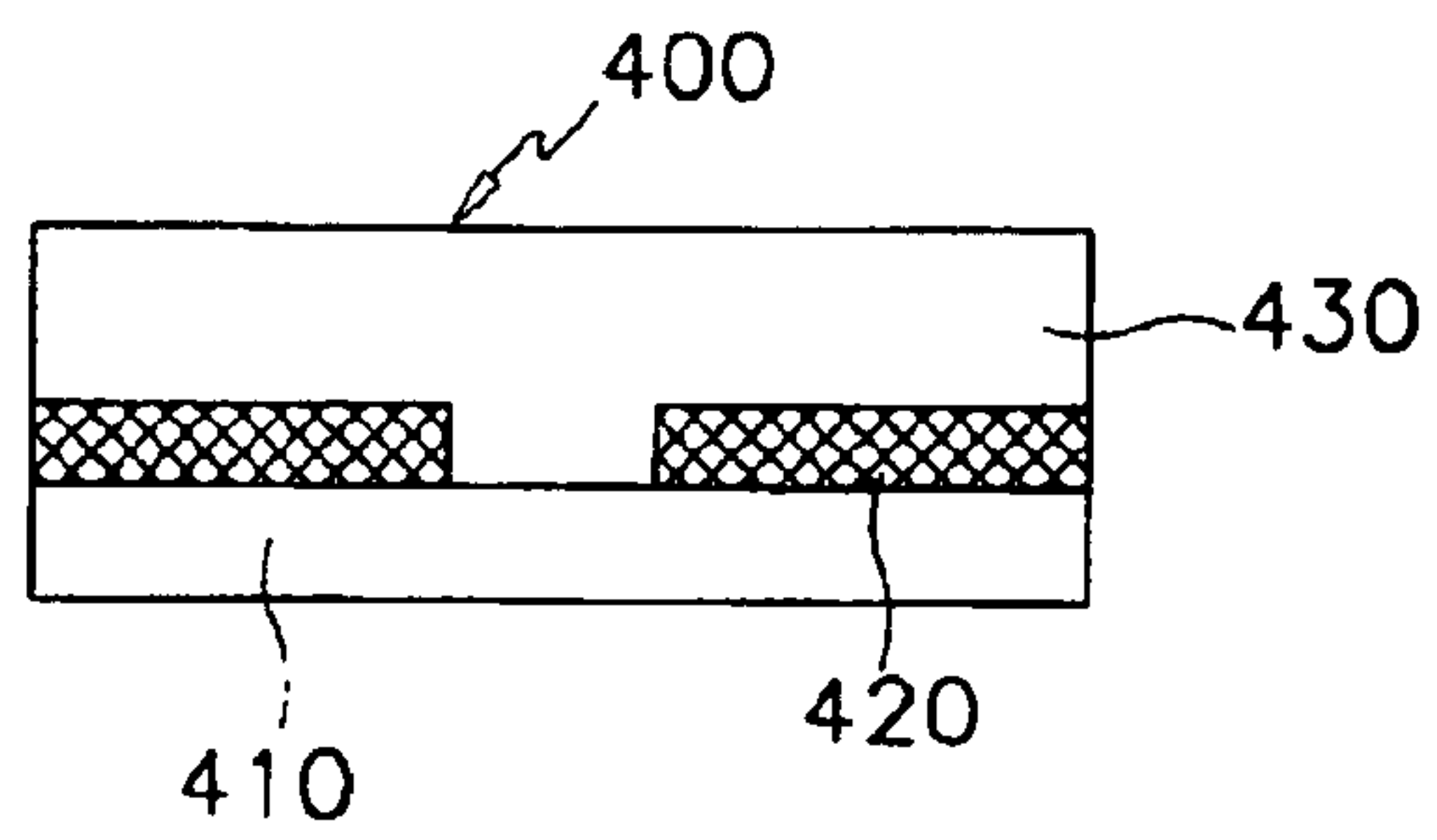

FIG.12

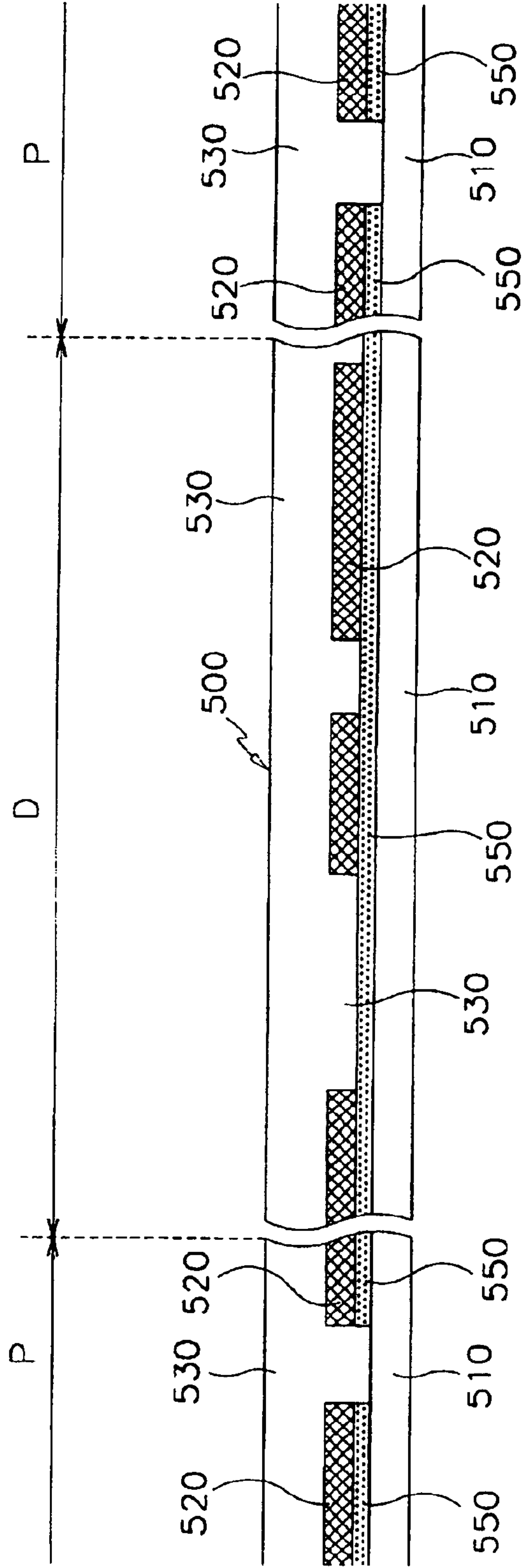

FIG. 13A

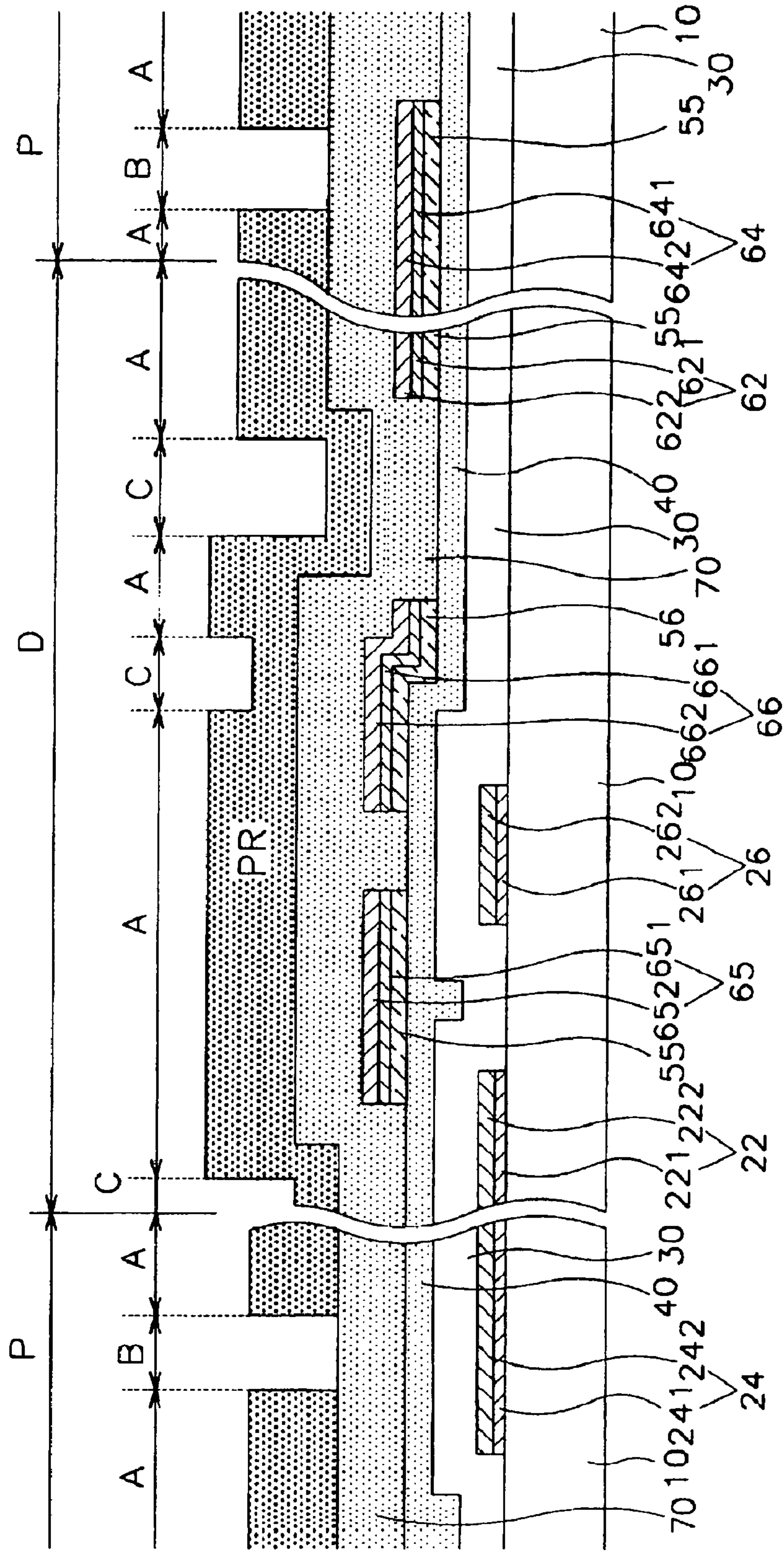

FIG. 13B

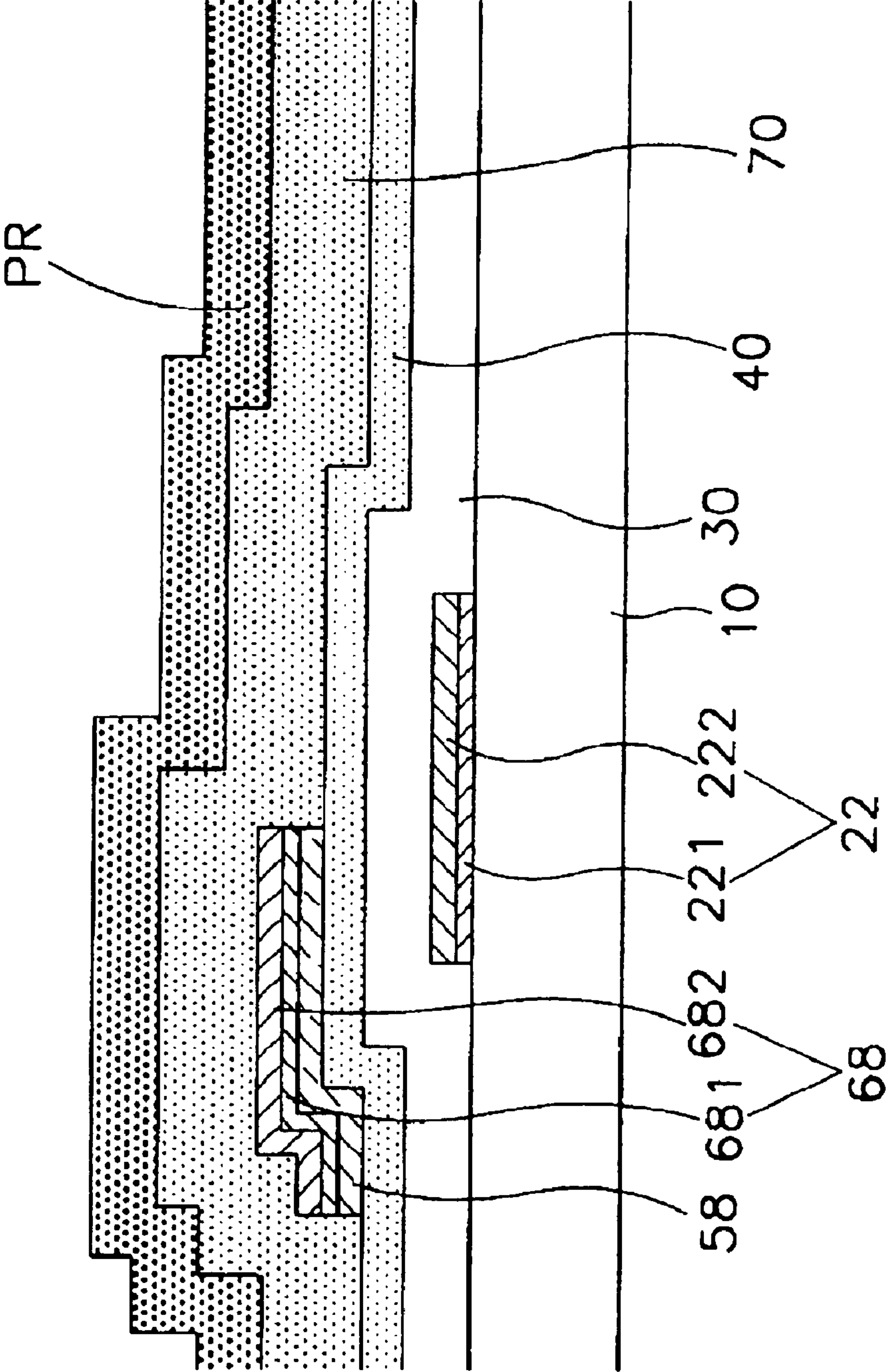

FIG. 14A

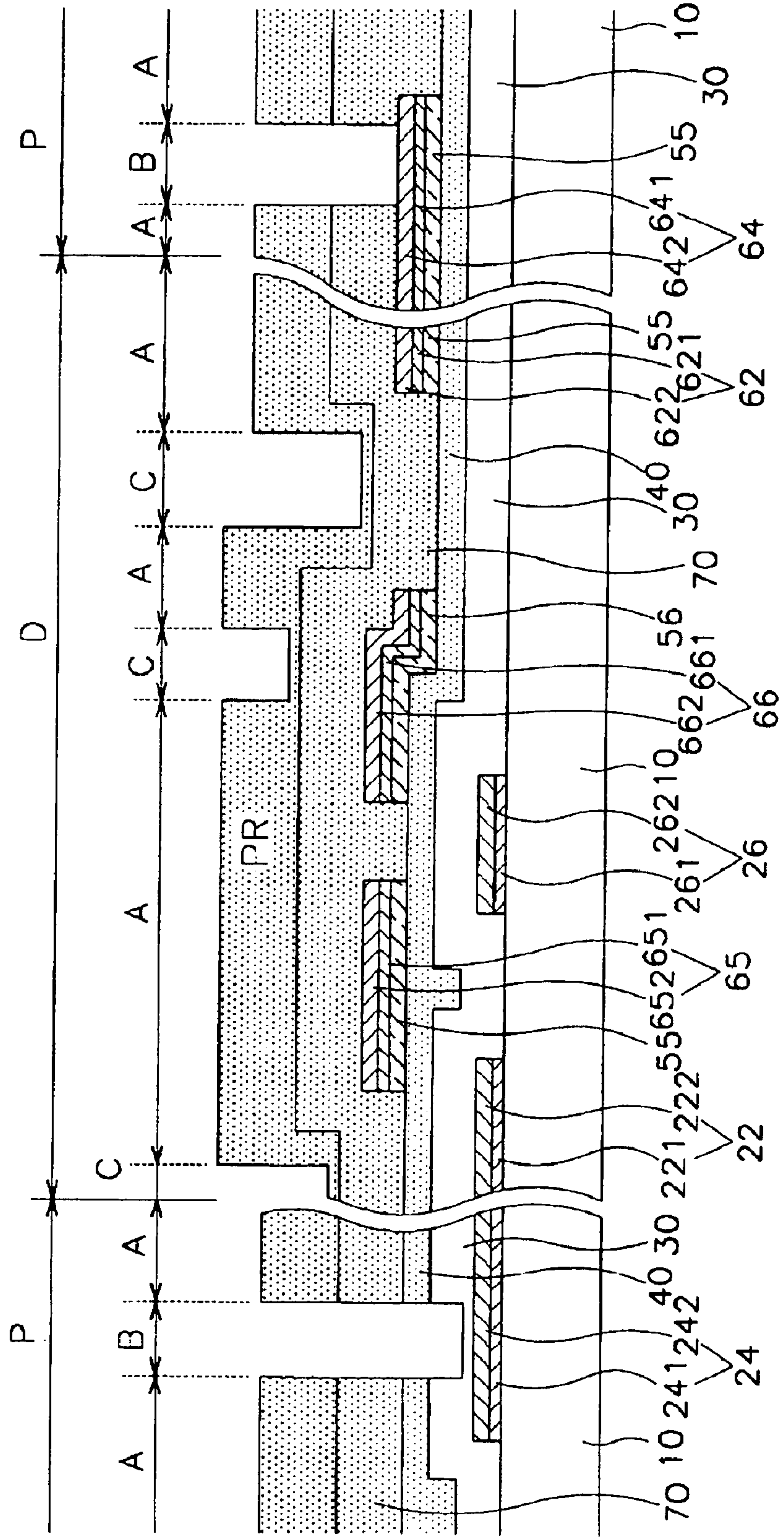

FIG. 14B

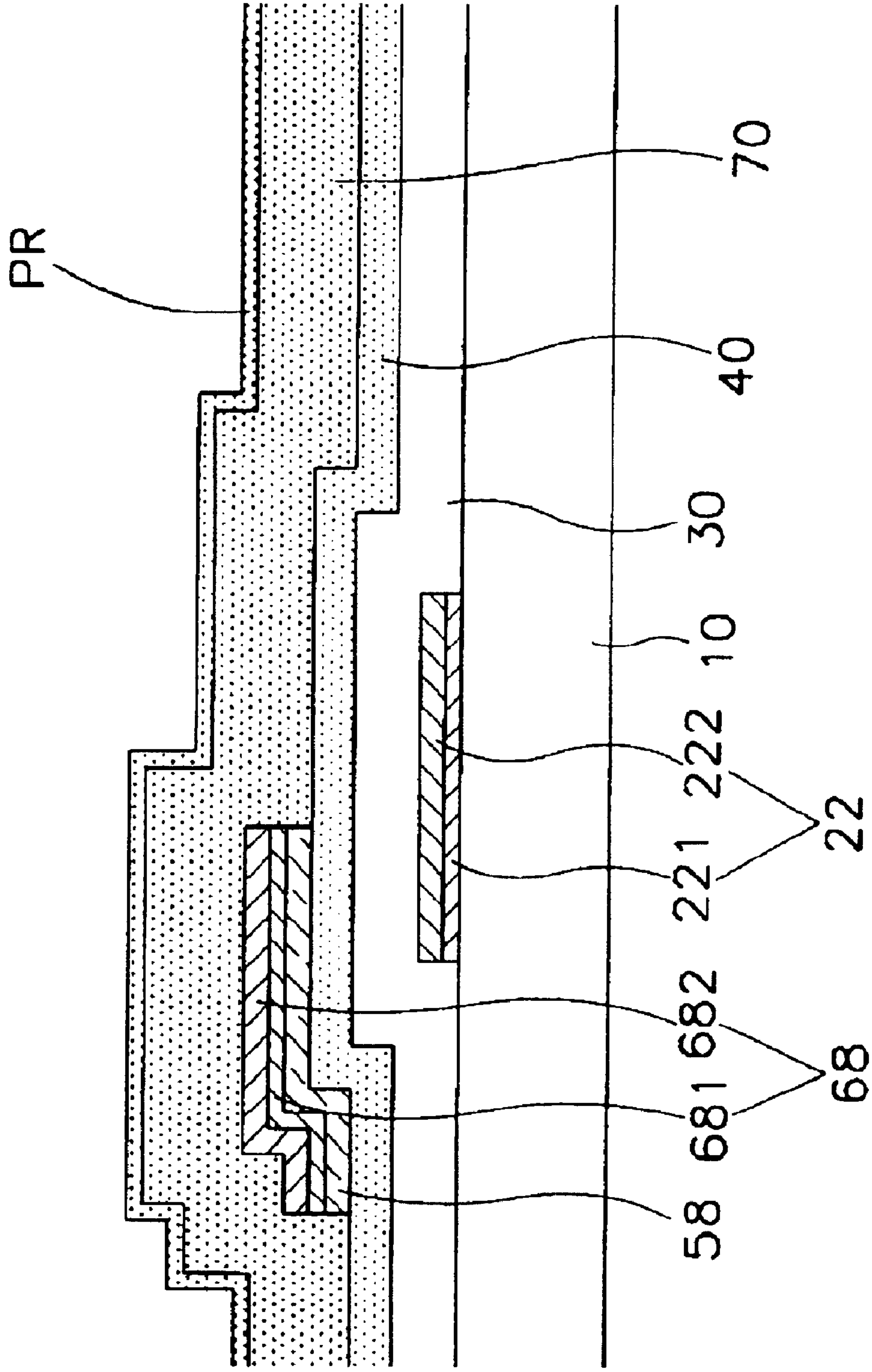

FIG. 15A

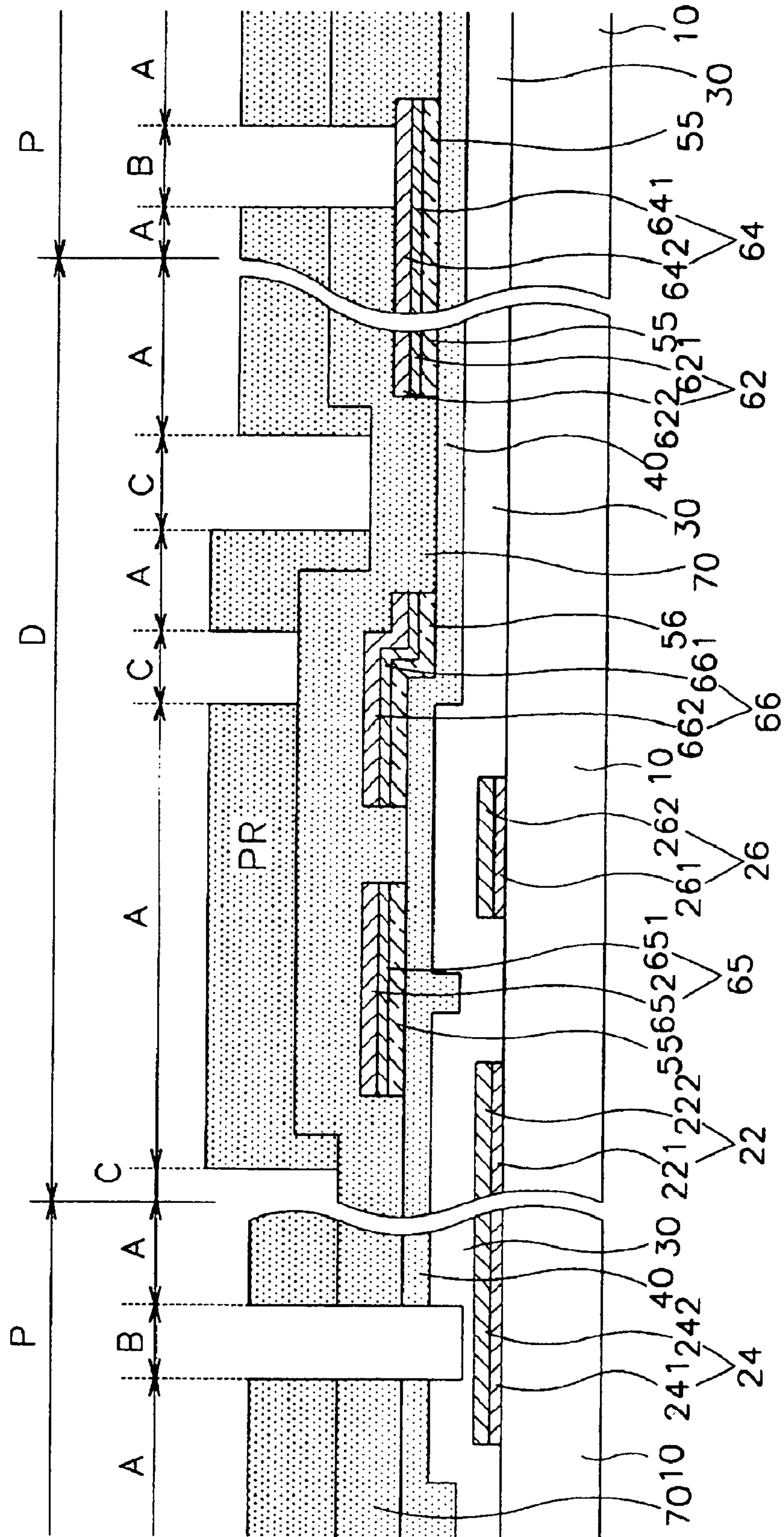

FIG. 15B

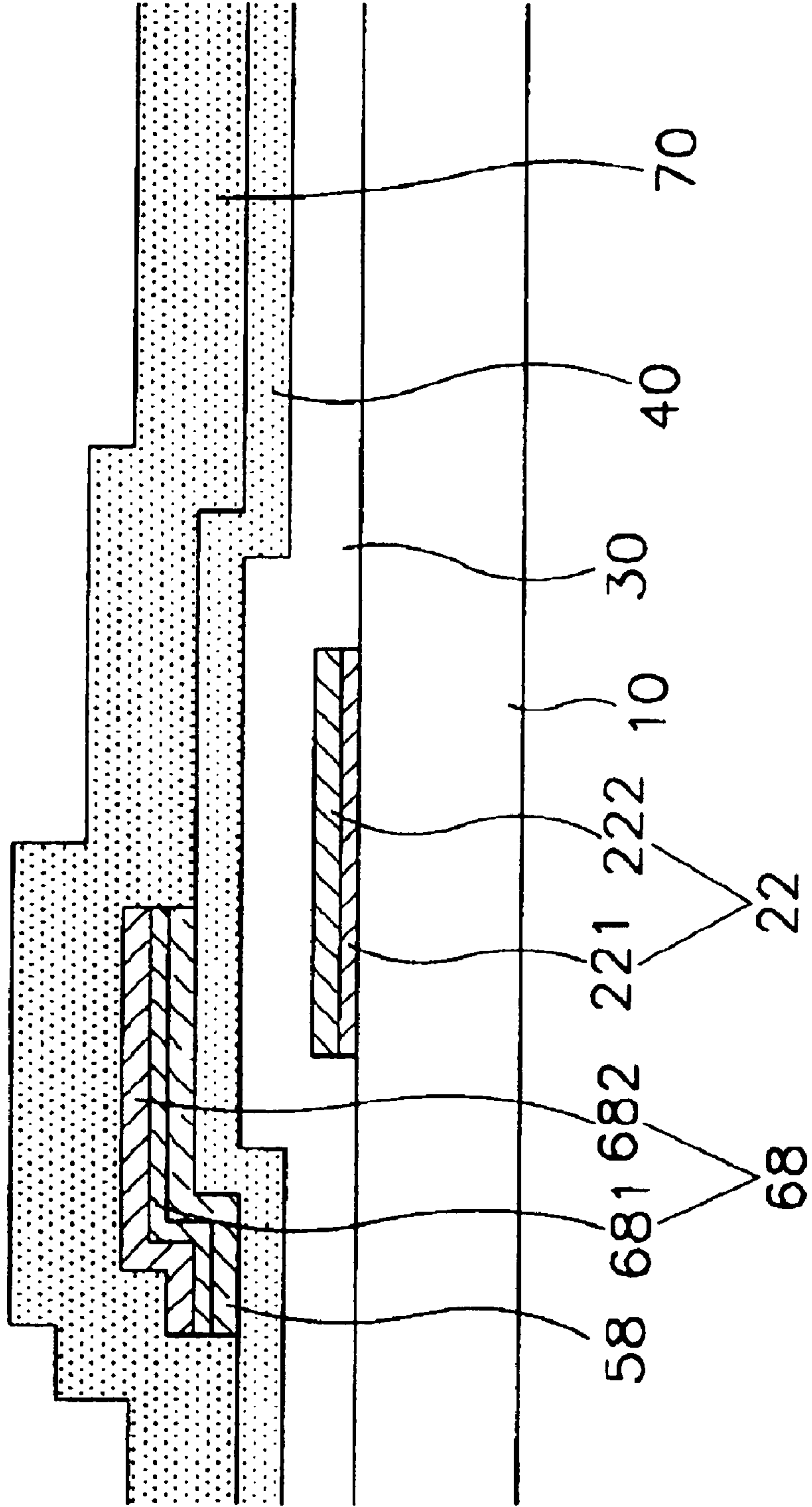

FIG. 16A

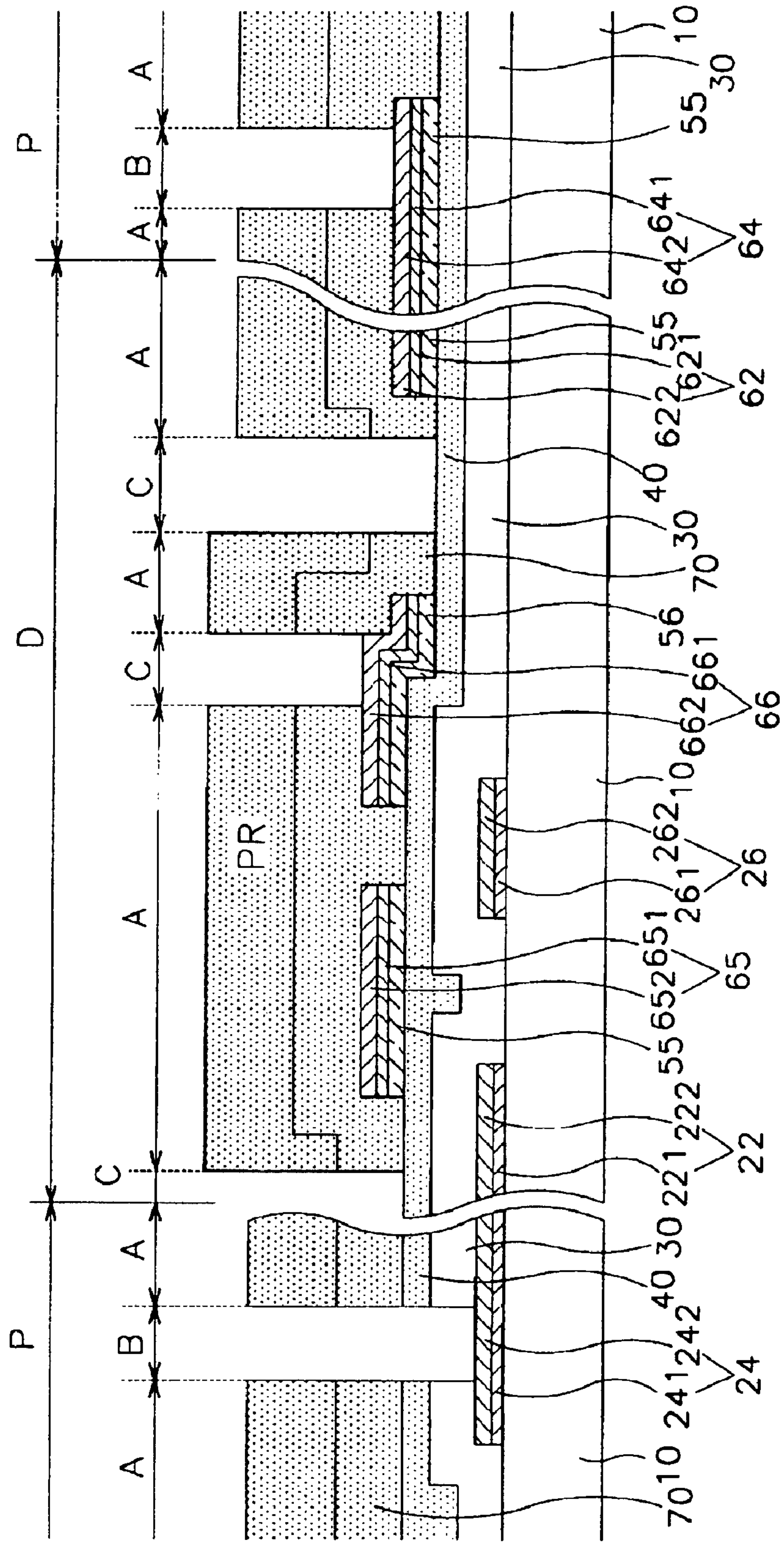

FIG. 16B

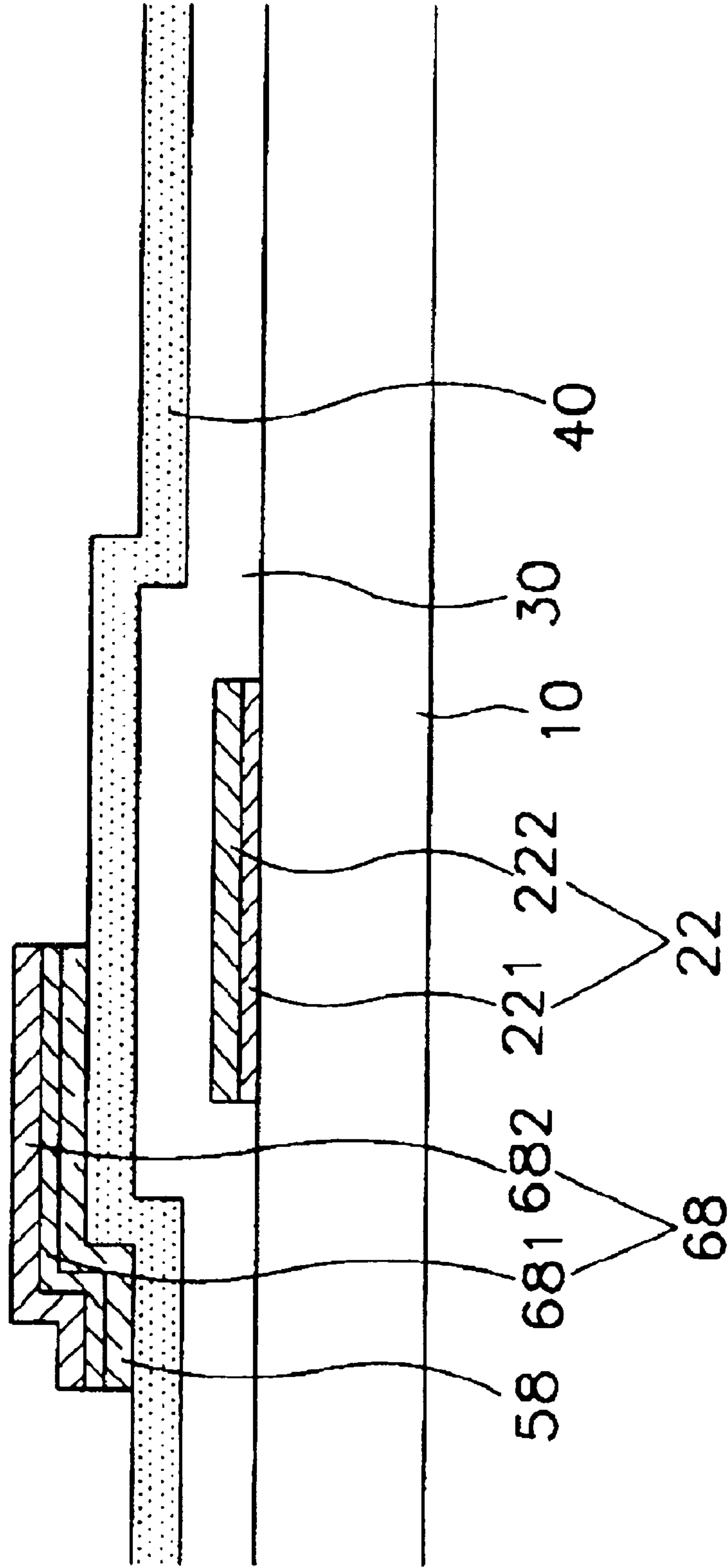

FIG. 17A

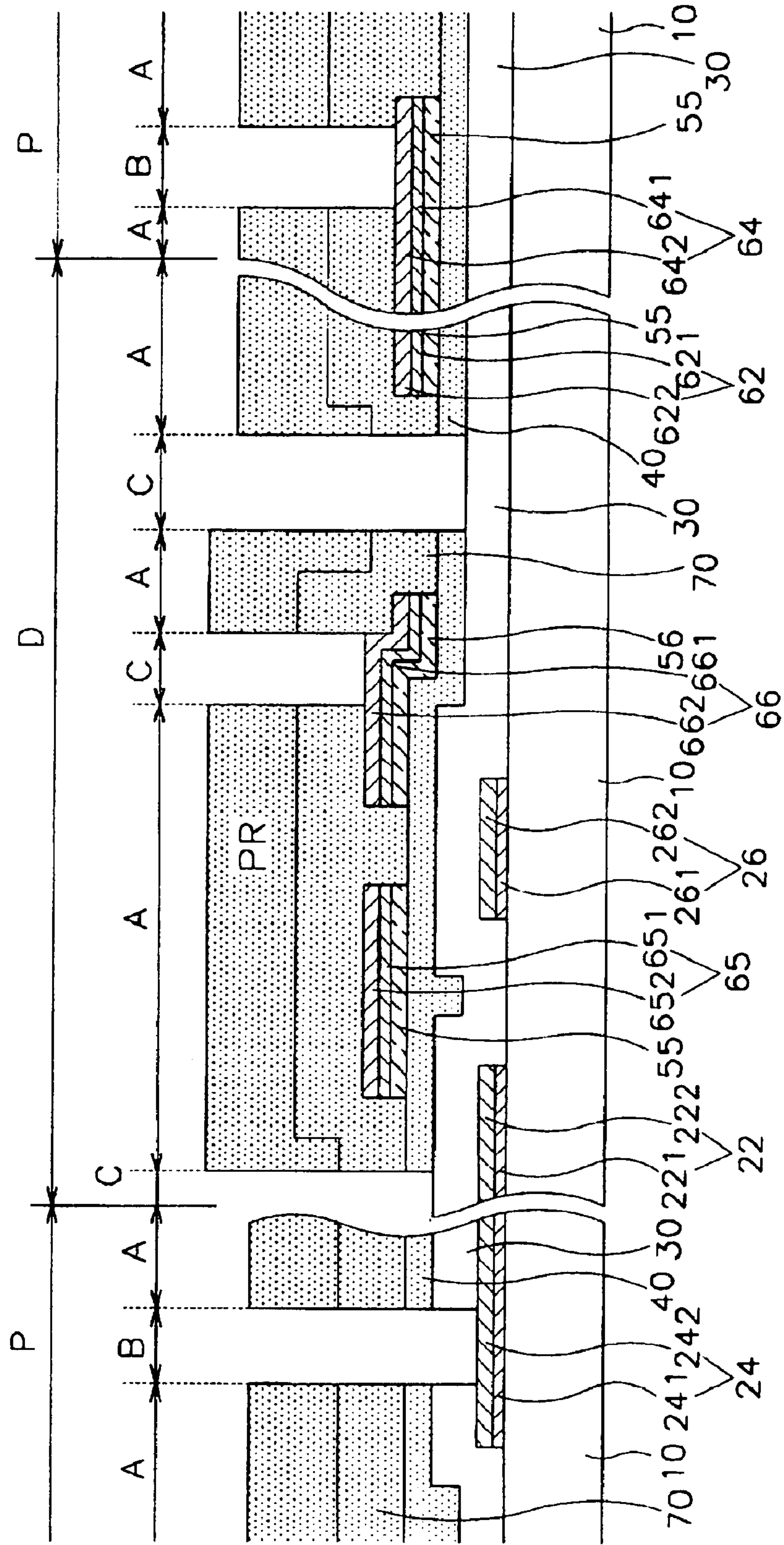

FIG. 17B

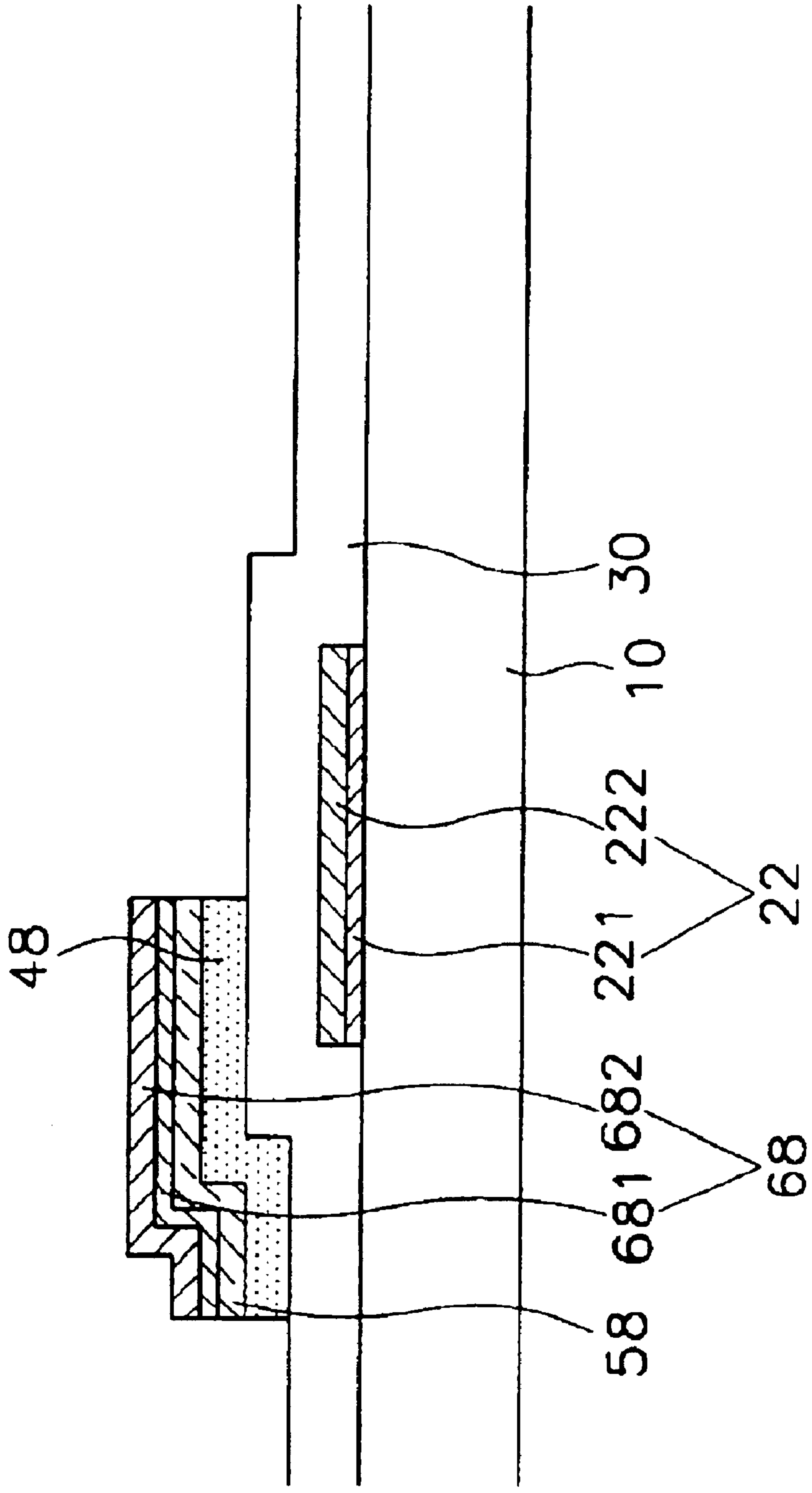

FIG. 18

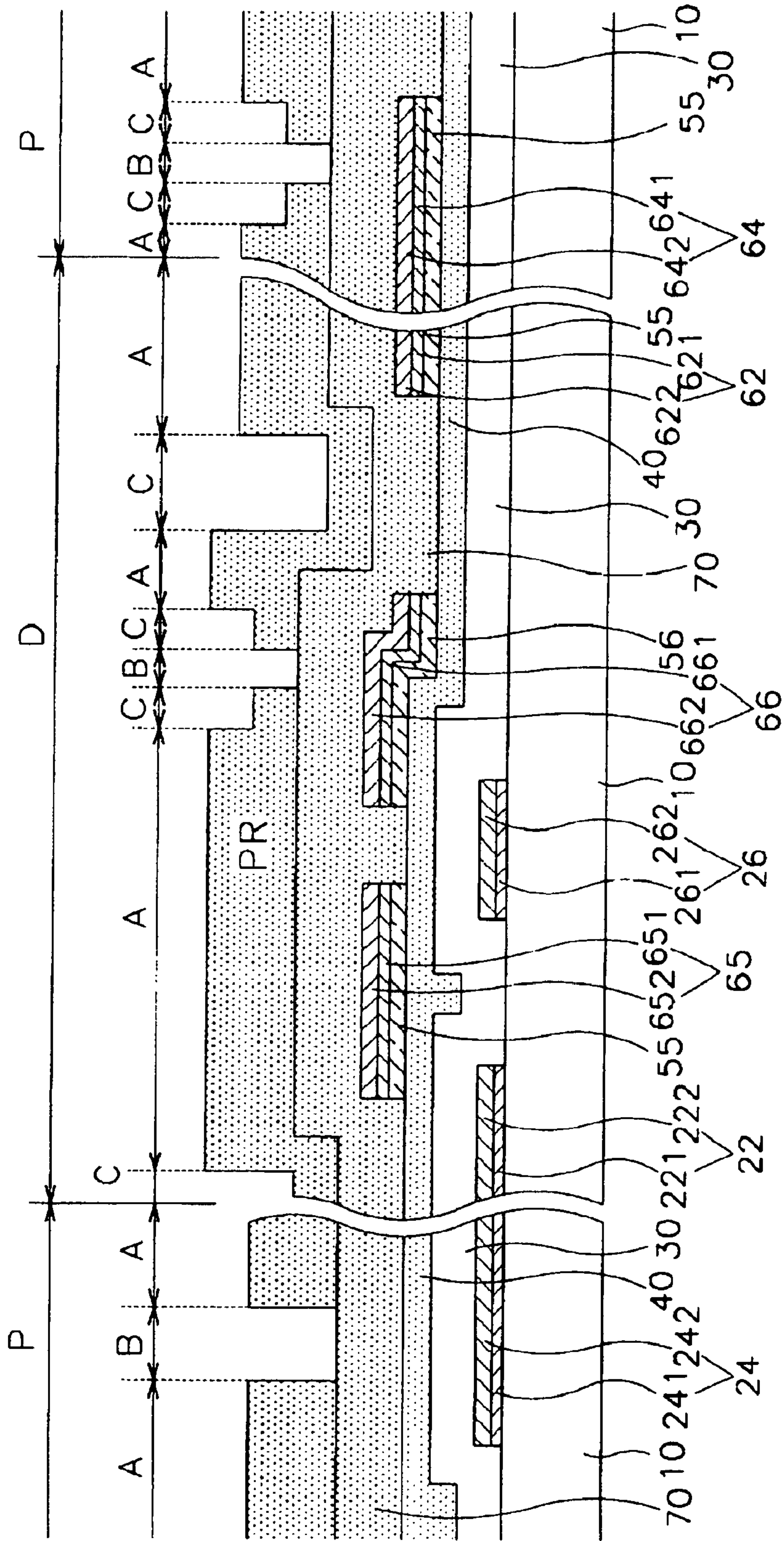

FIG. 19

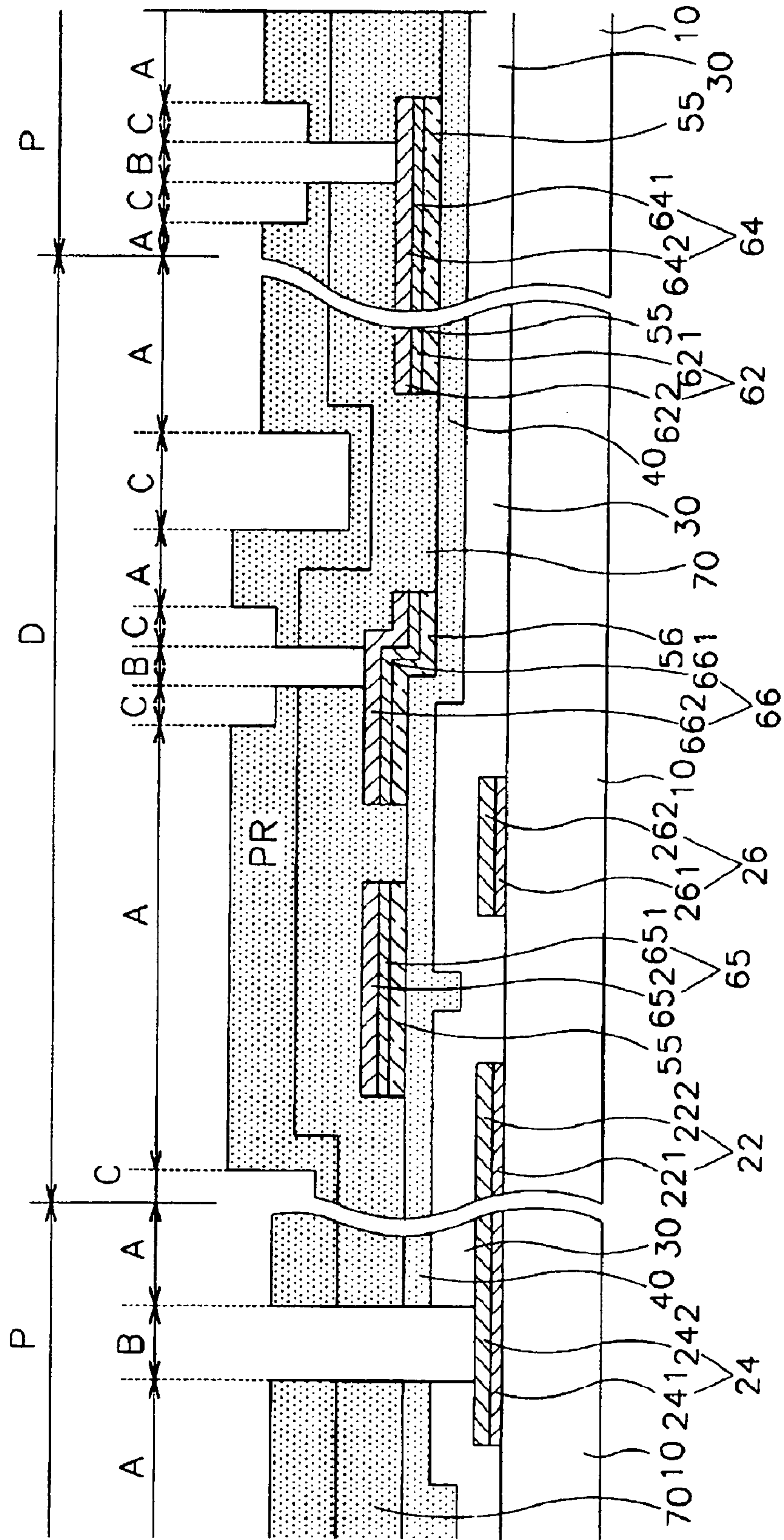

FIG. 20

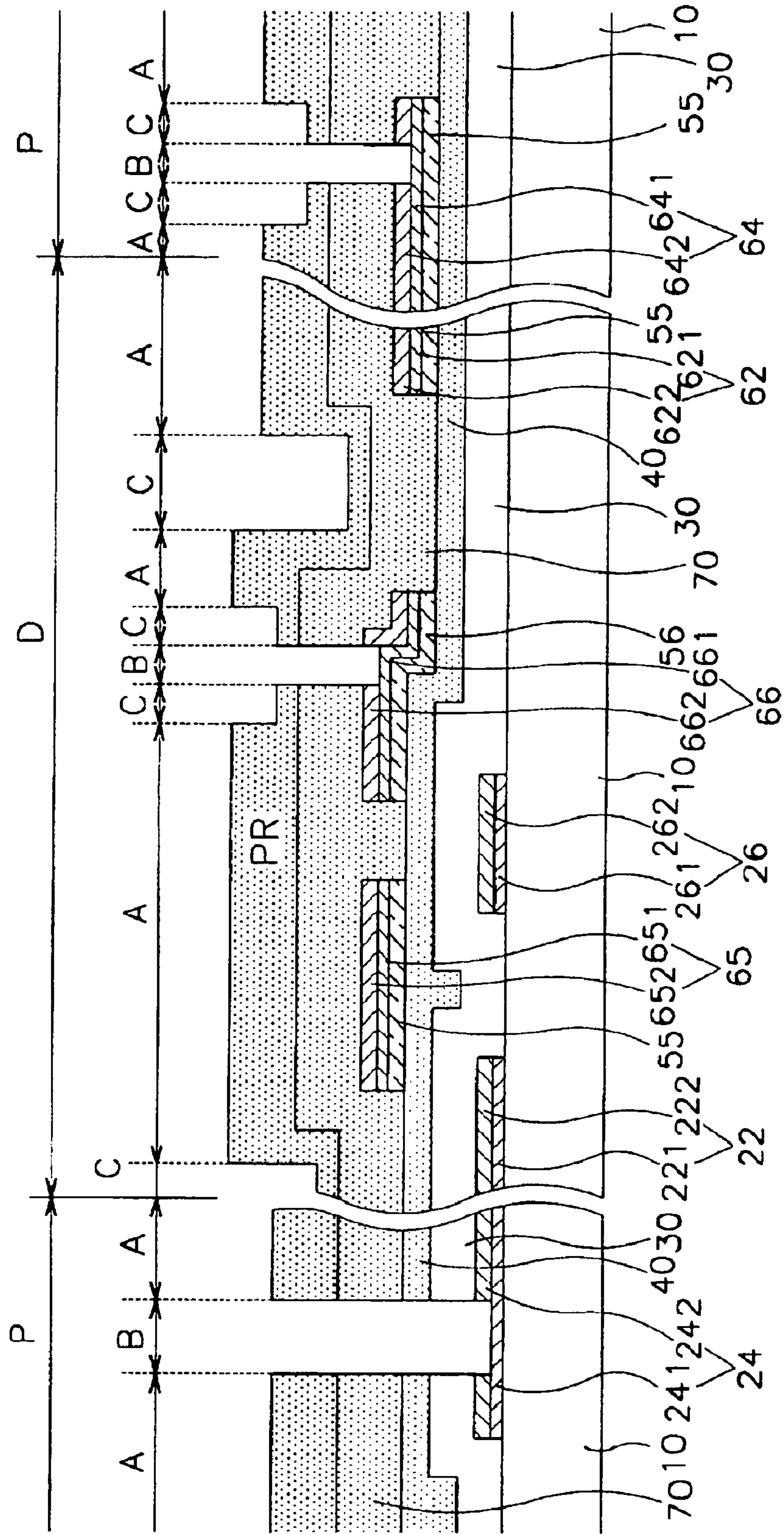

FIG. 21

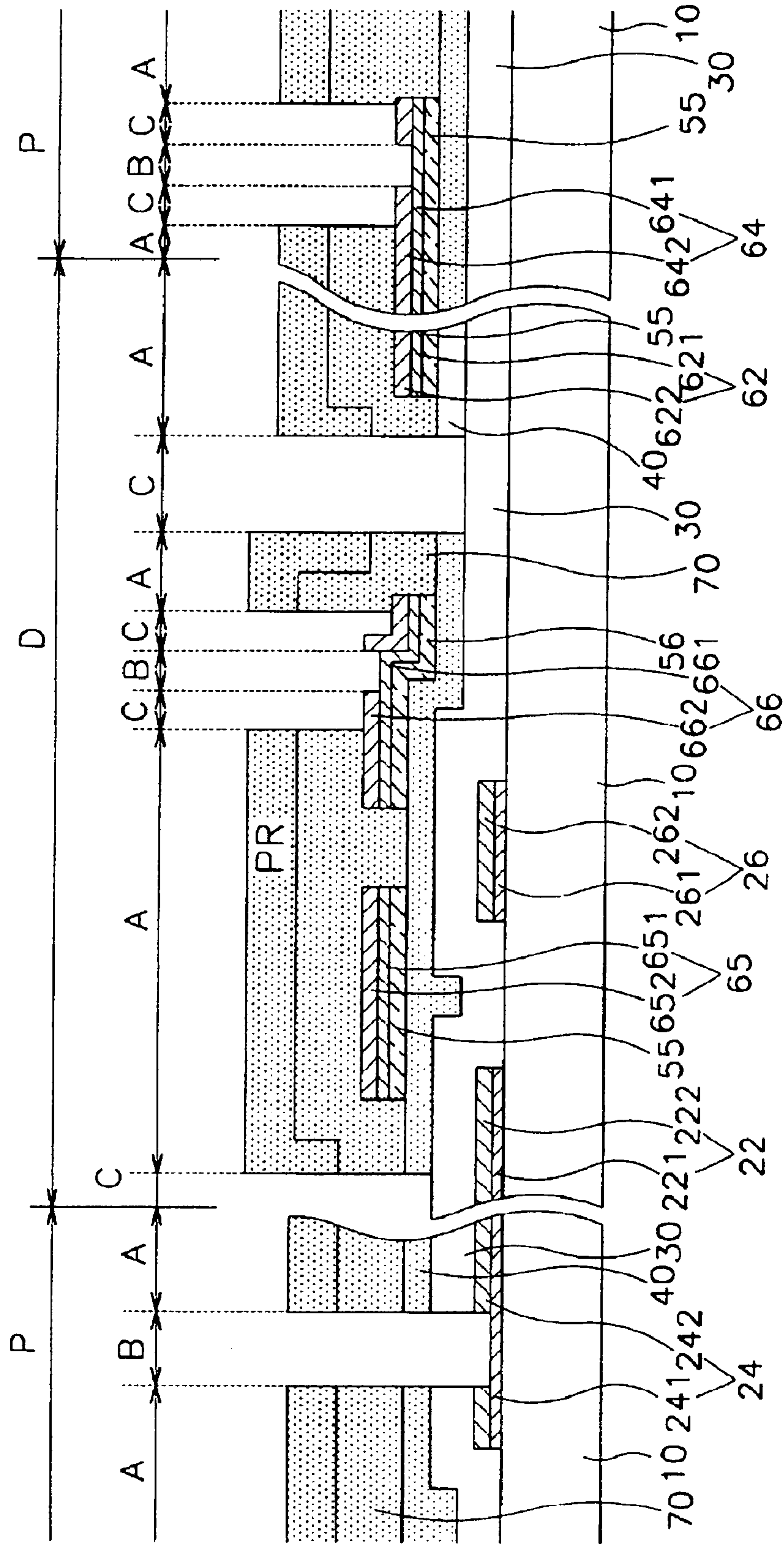

FIG. 22

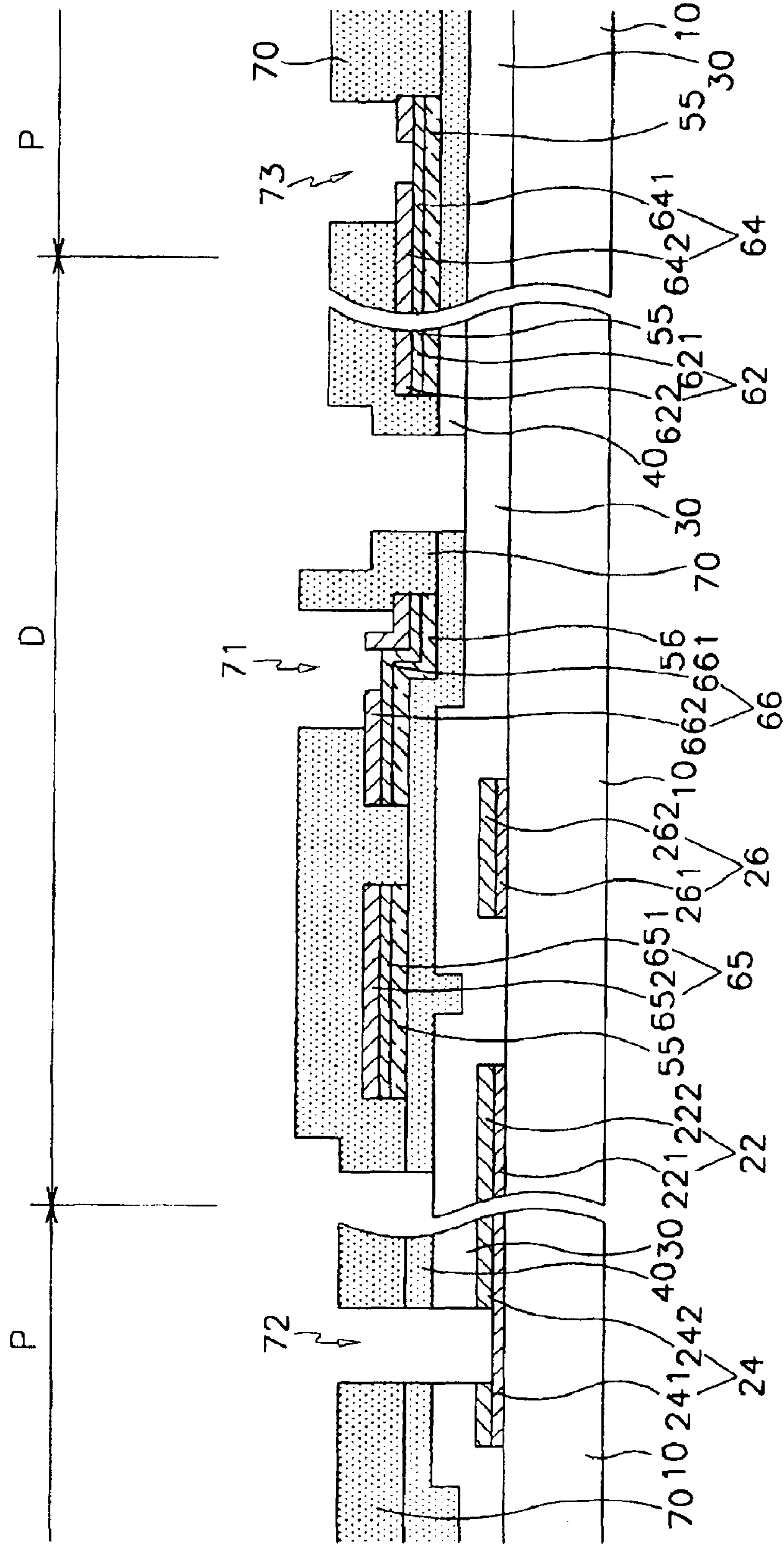

FIG. 23

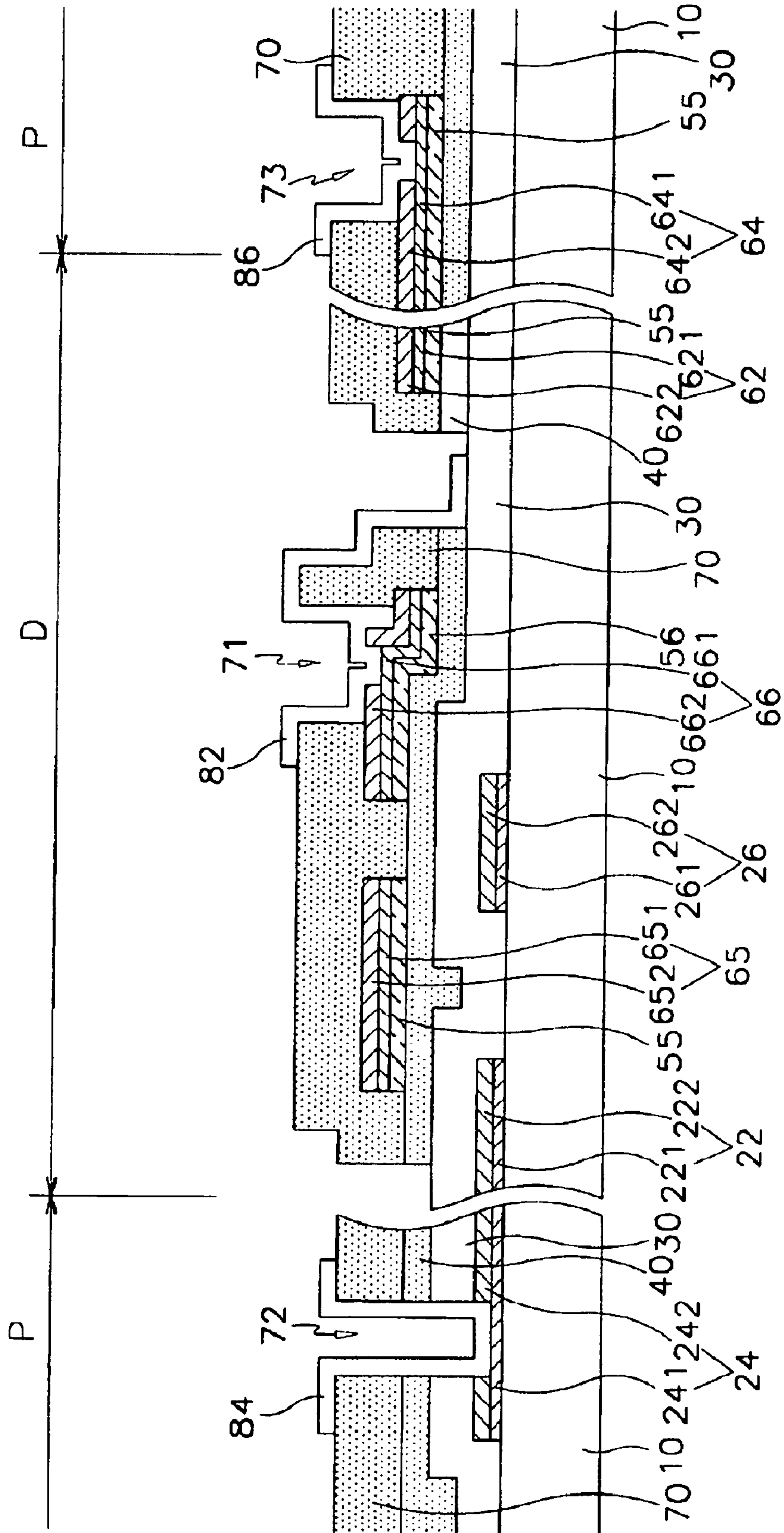
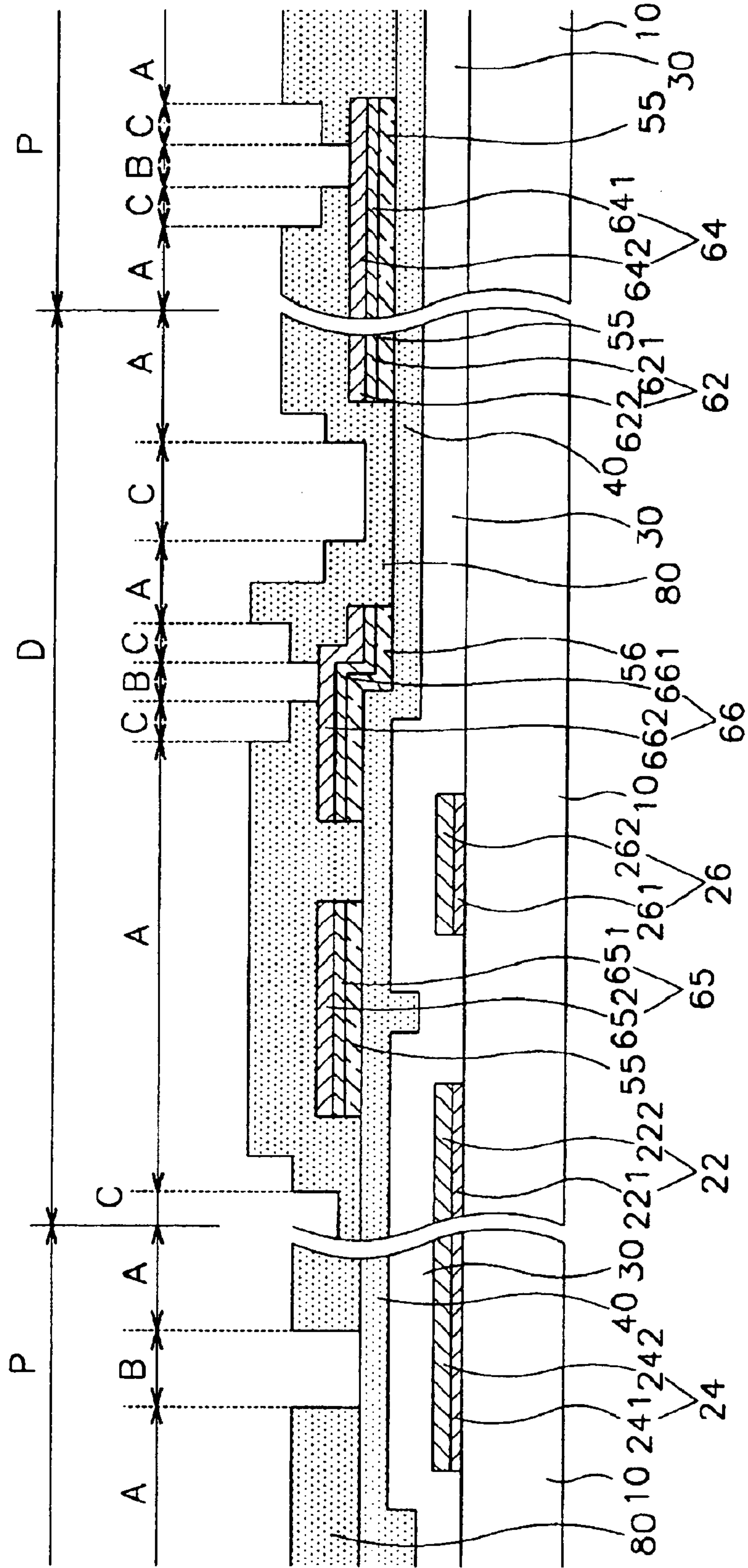

FIG. 24



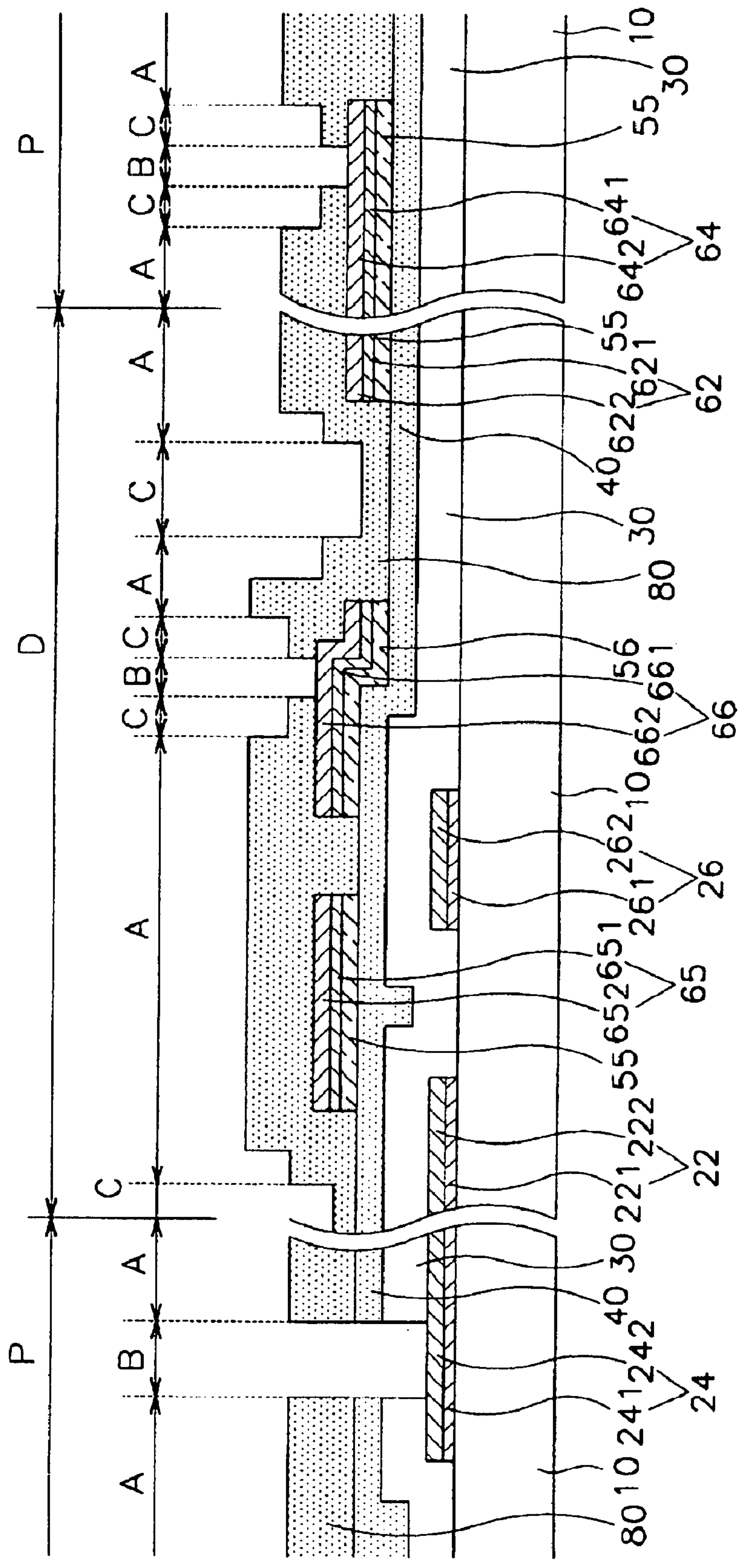

FIG. 25

FIG. 26

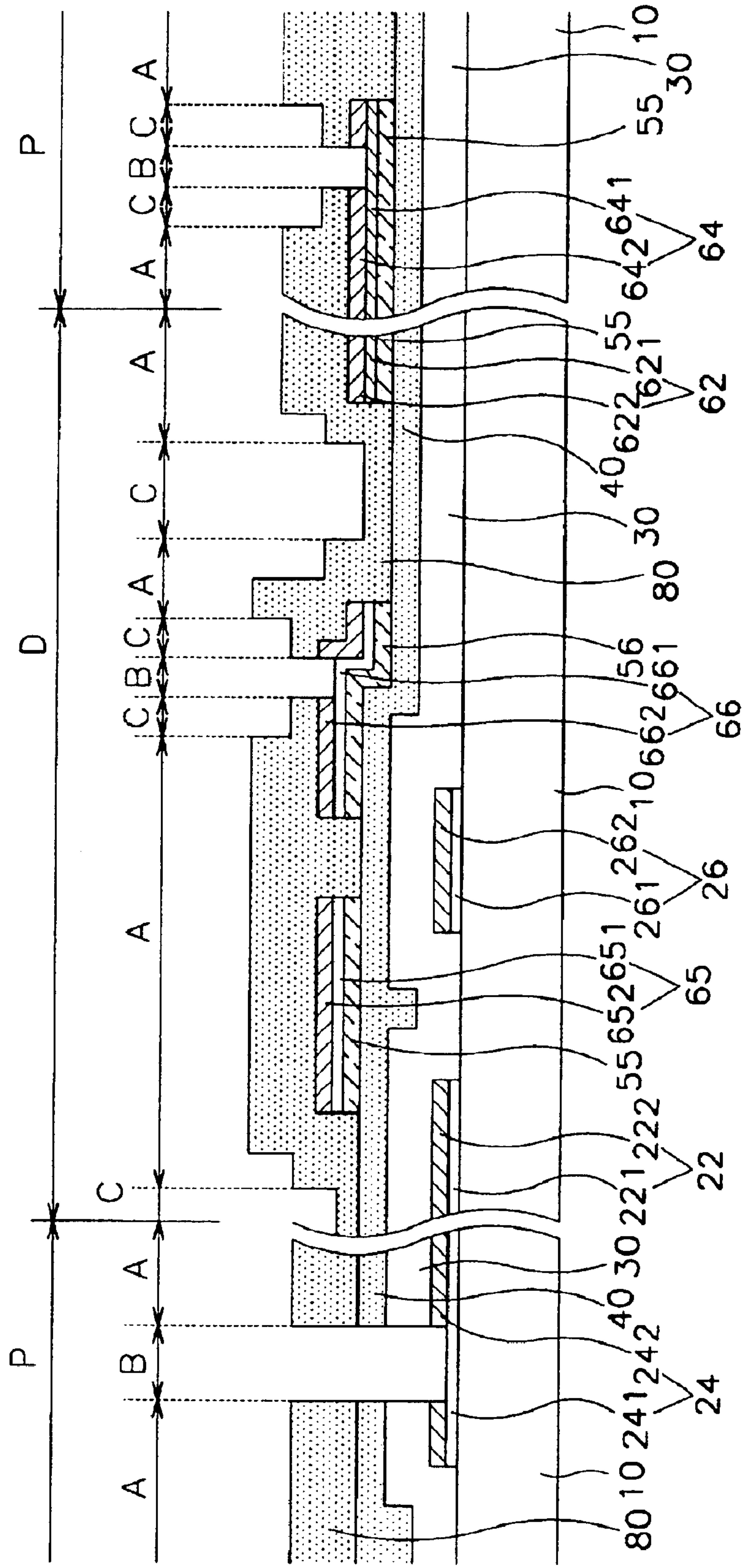

FIG. 27

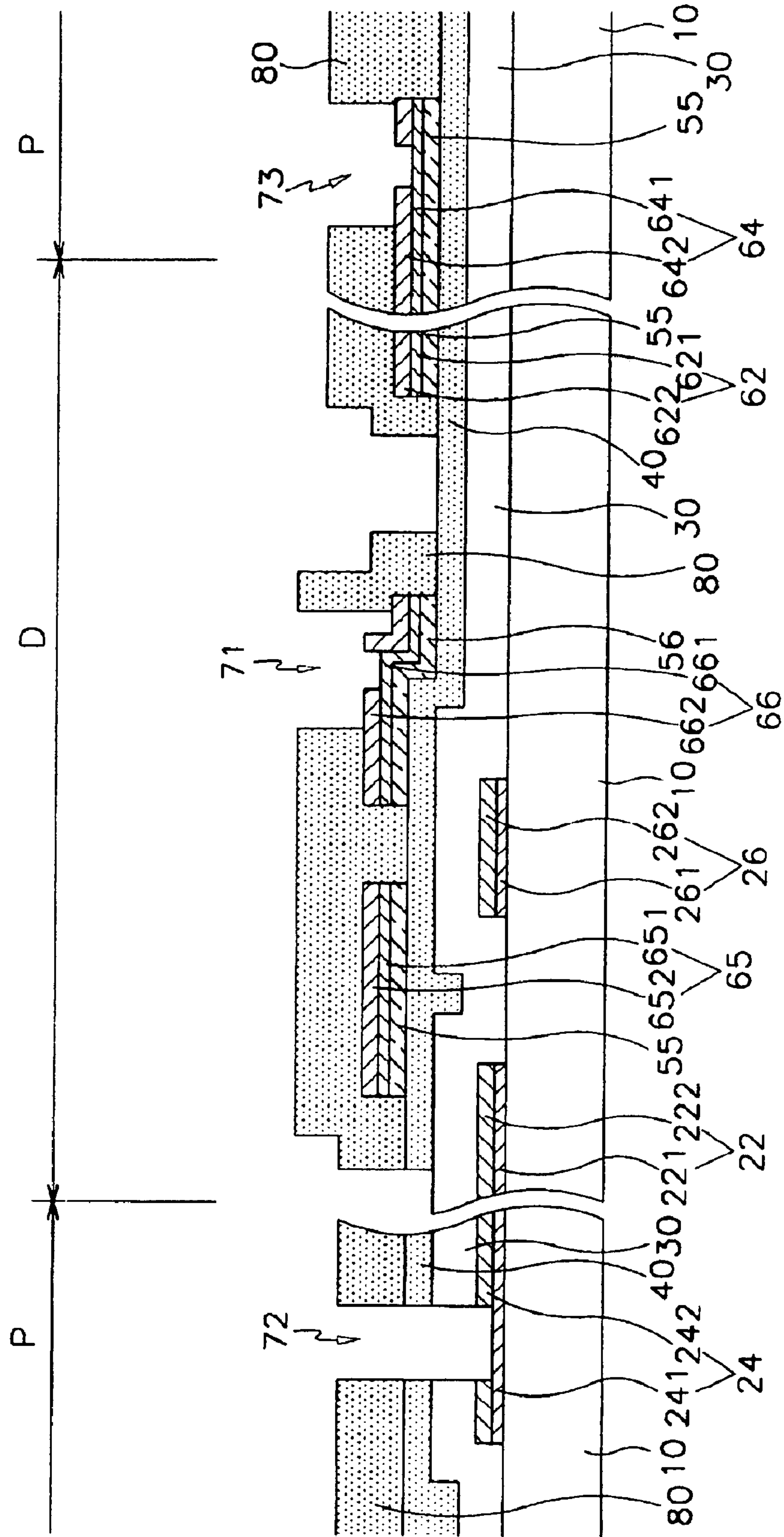

FIG. 28

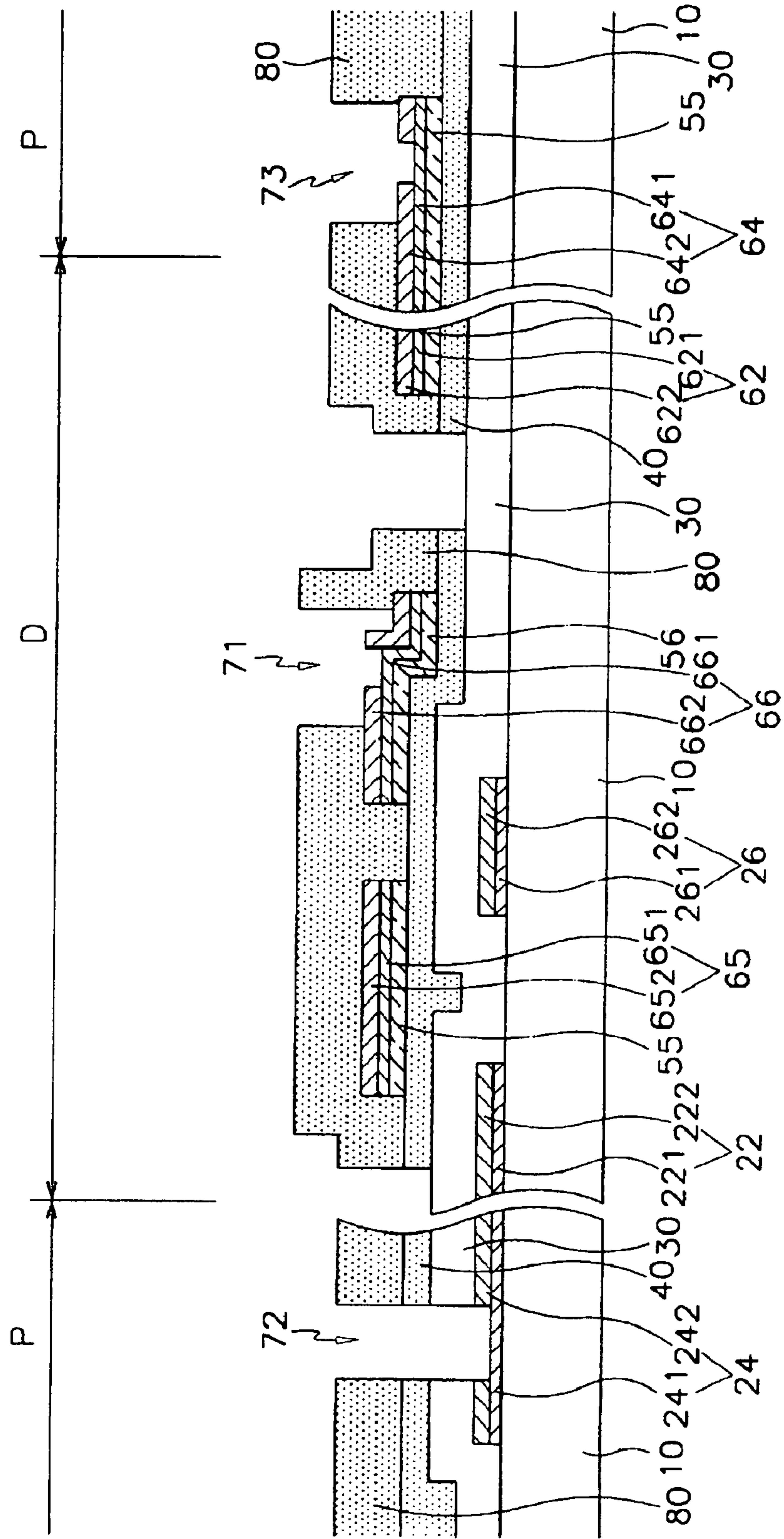

FIG. 29

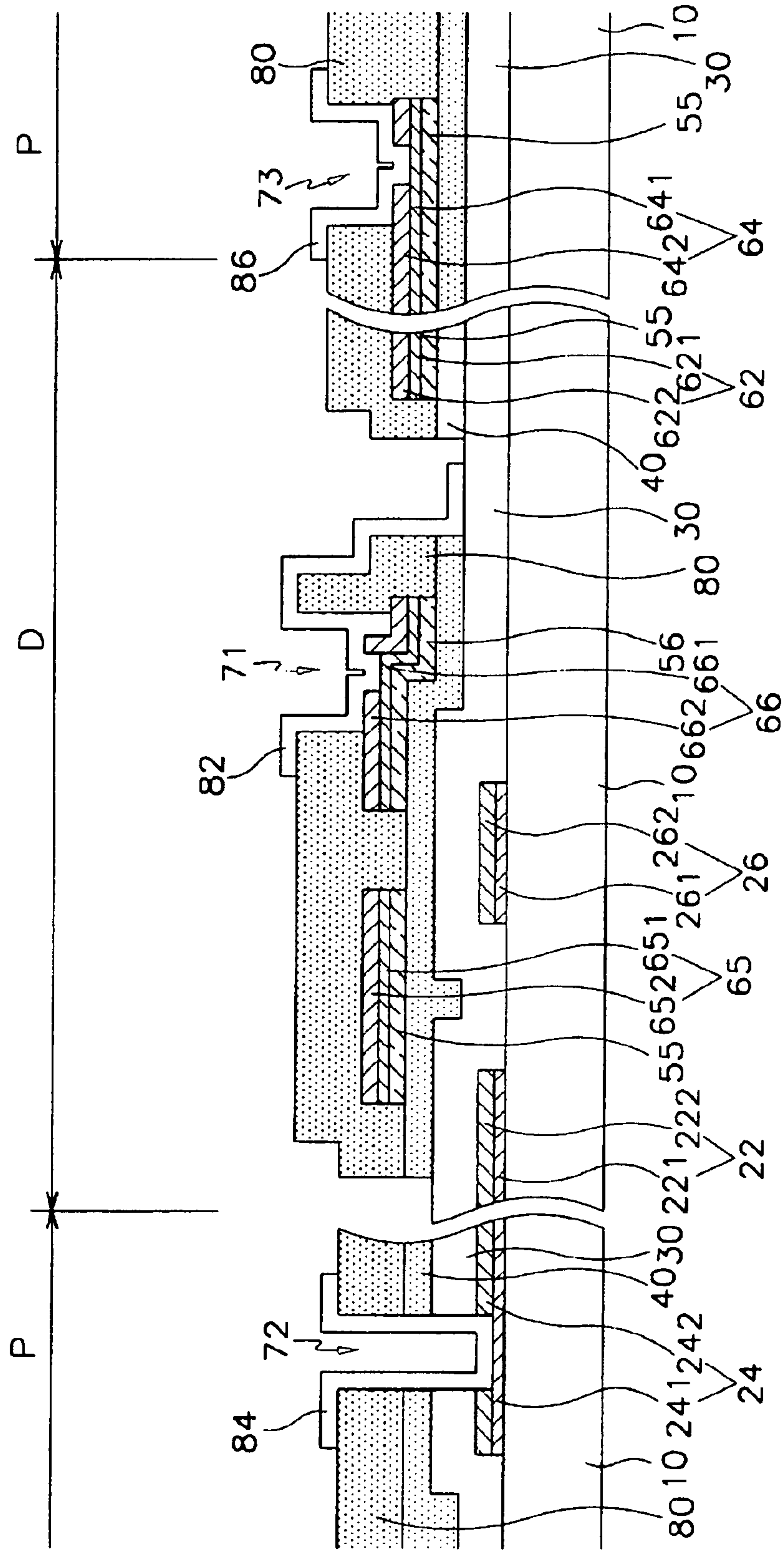

FIG. 30A

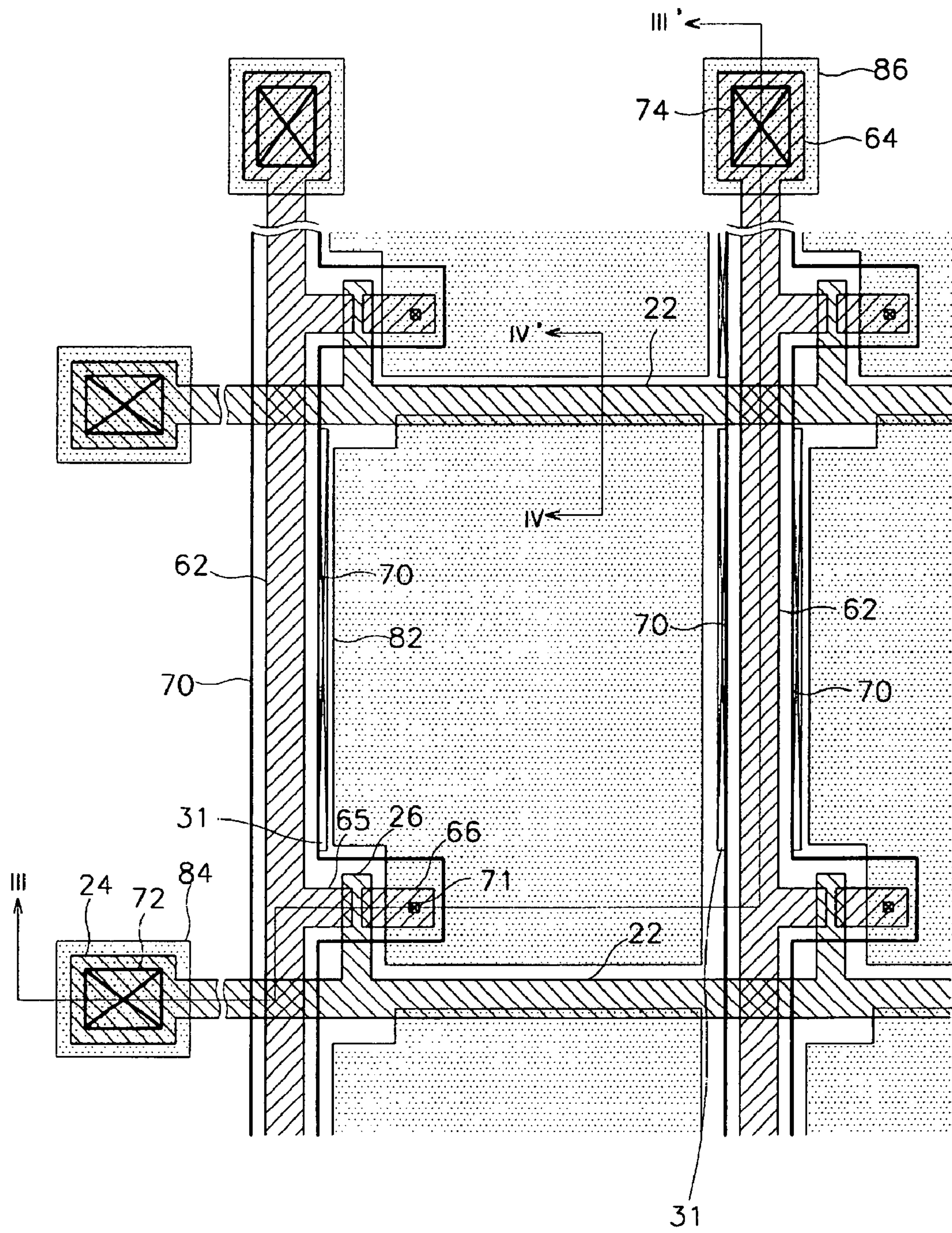

FIG. 30B

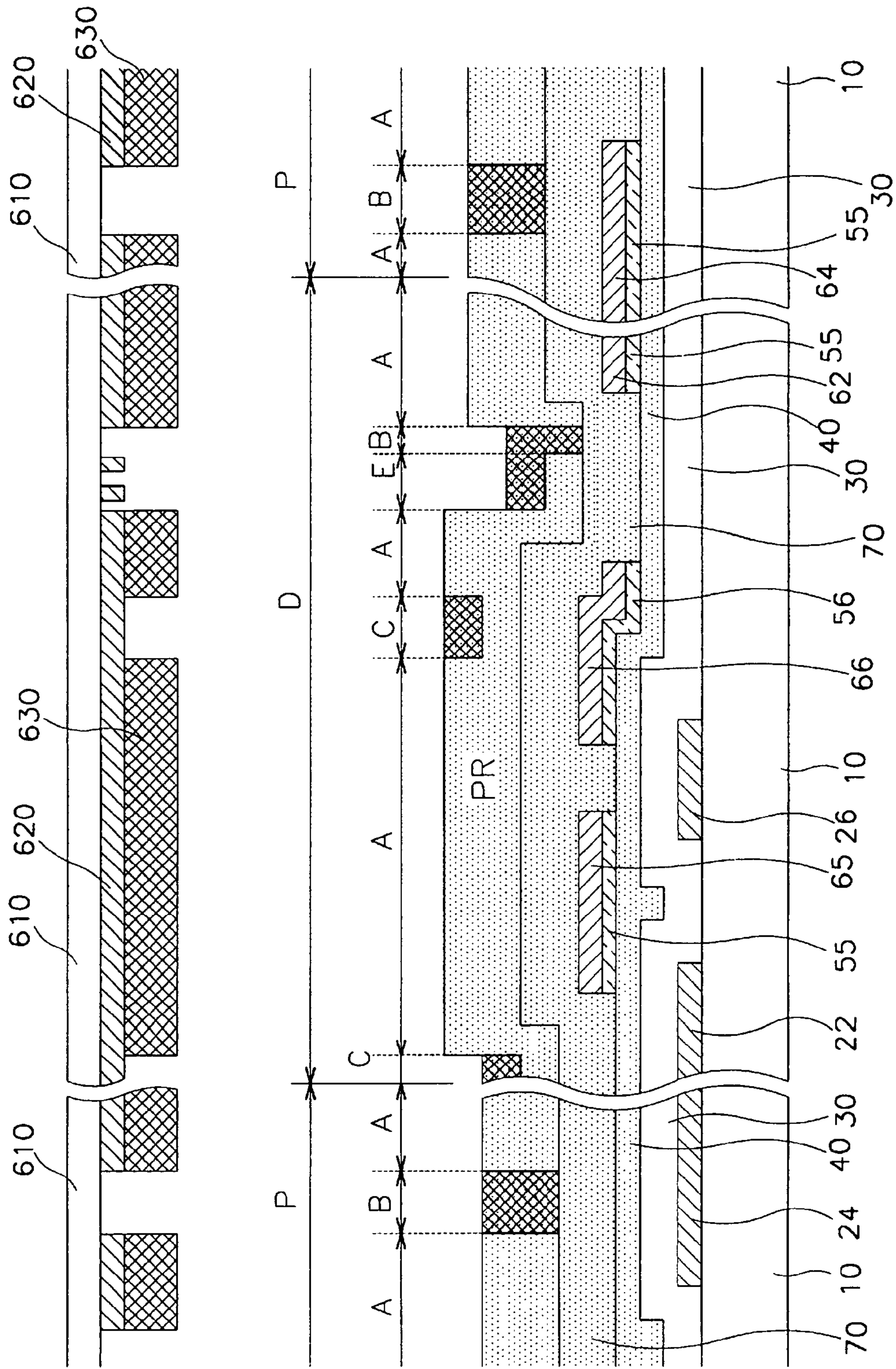

FIG. 30C

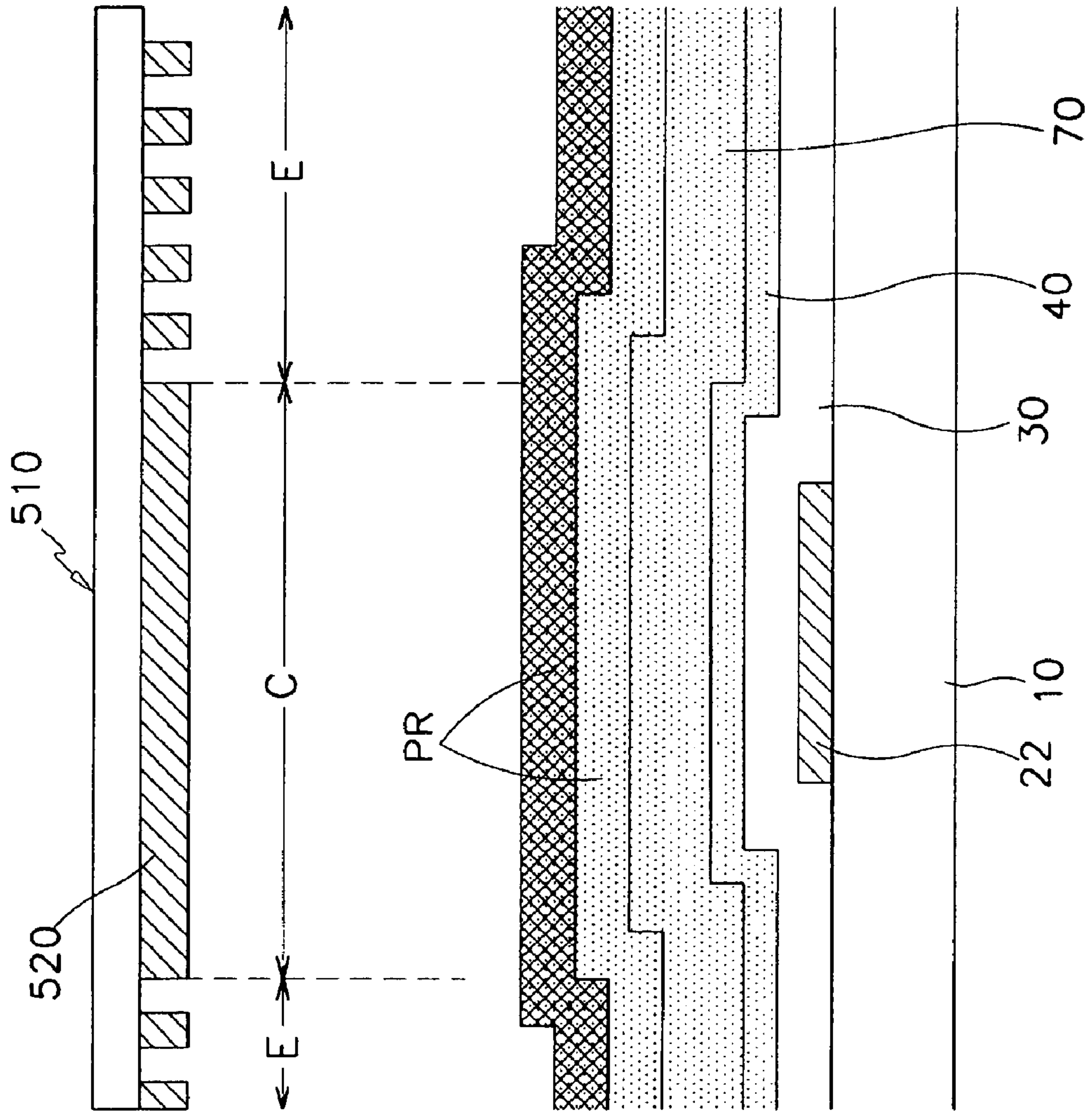

FIG. 31

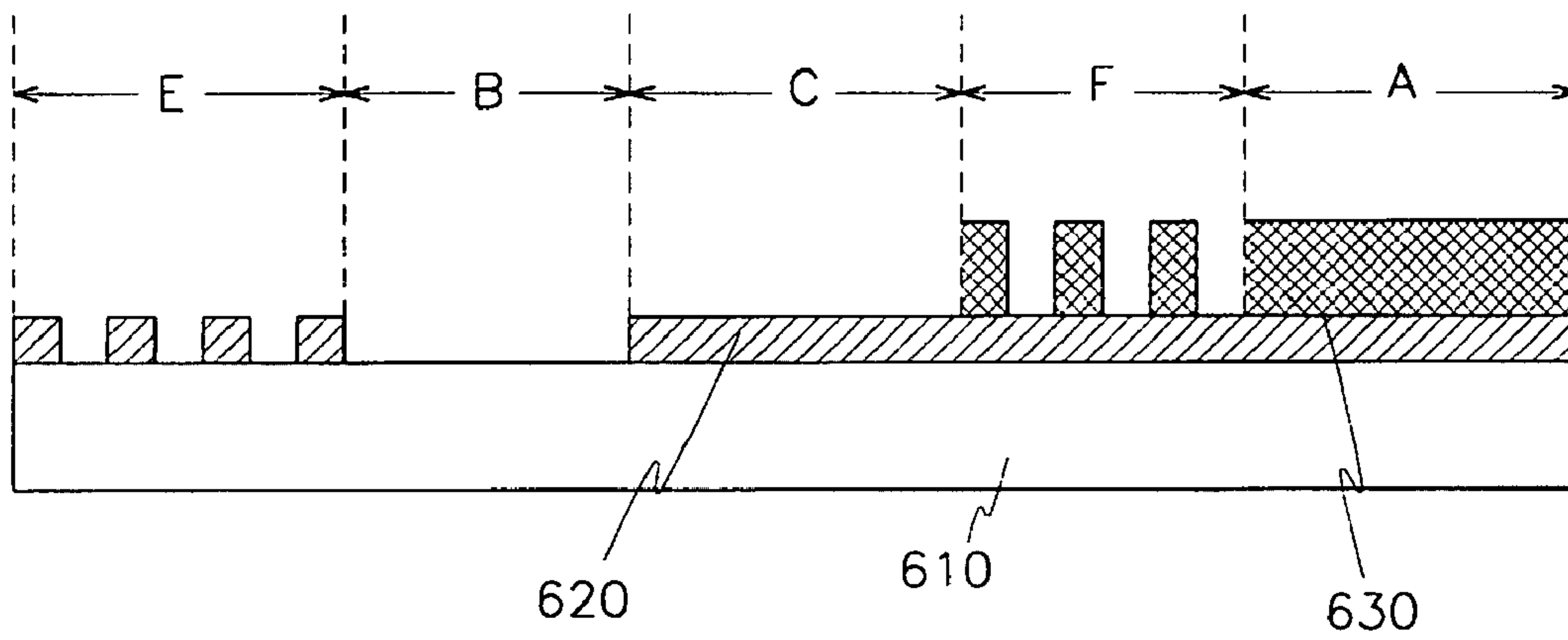

FIG. 32A

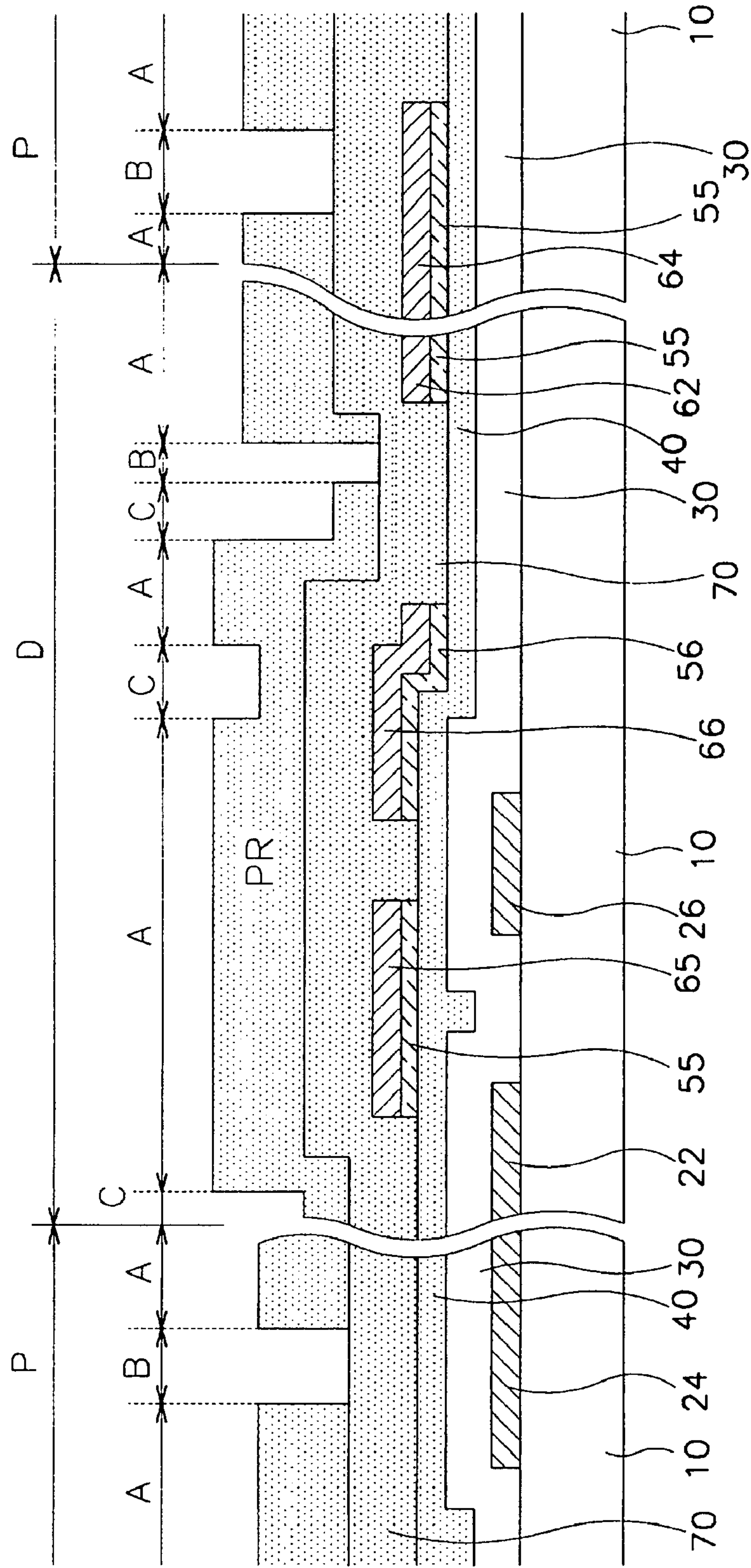

FIG. 32B

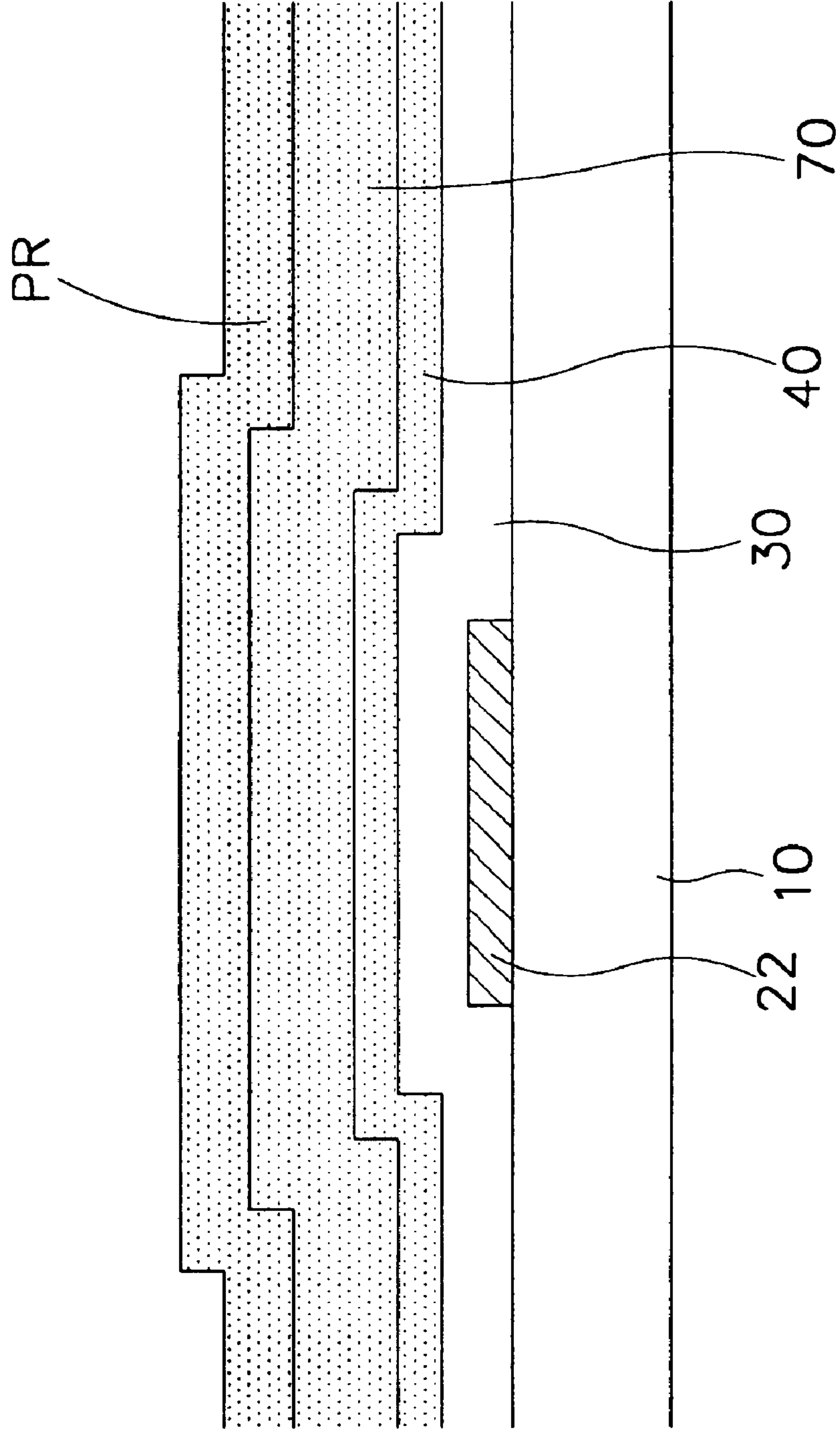

FIG. 33A

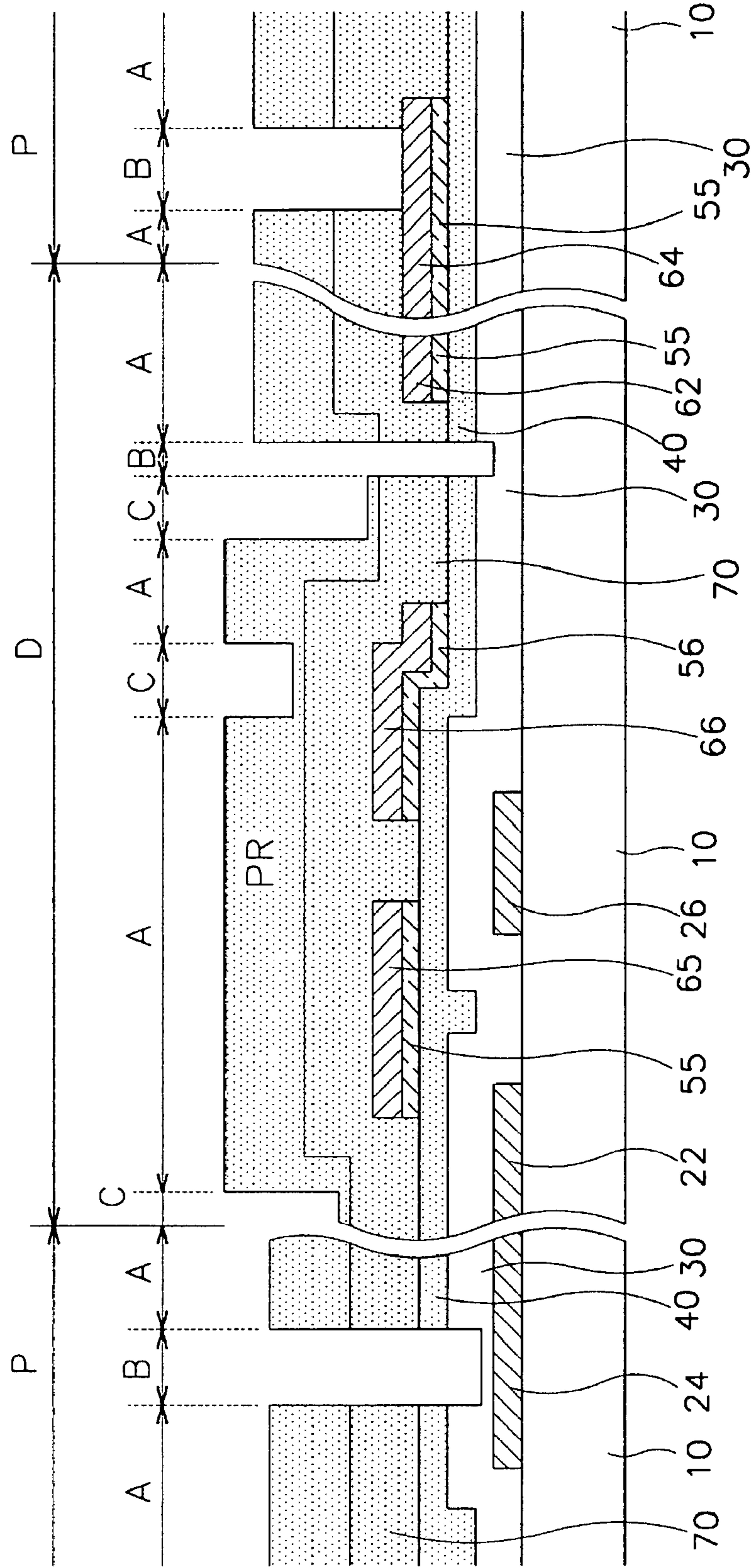

FIG. 33B

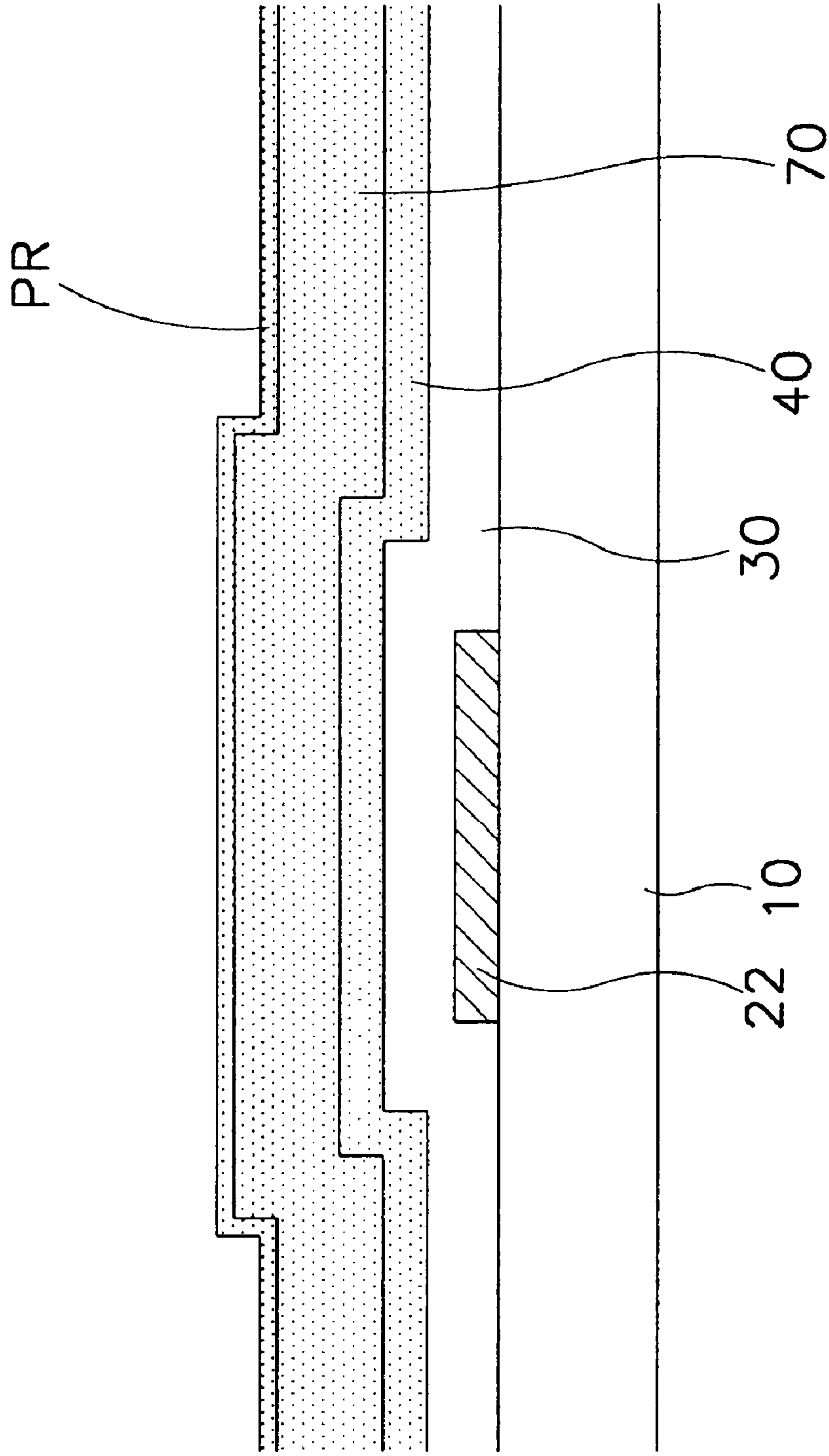

FIG. 34A

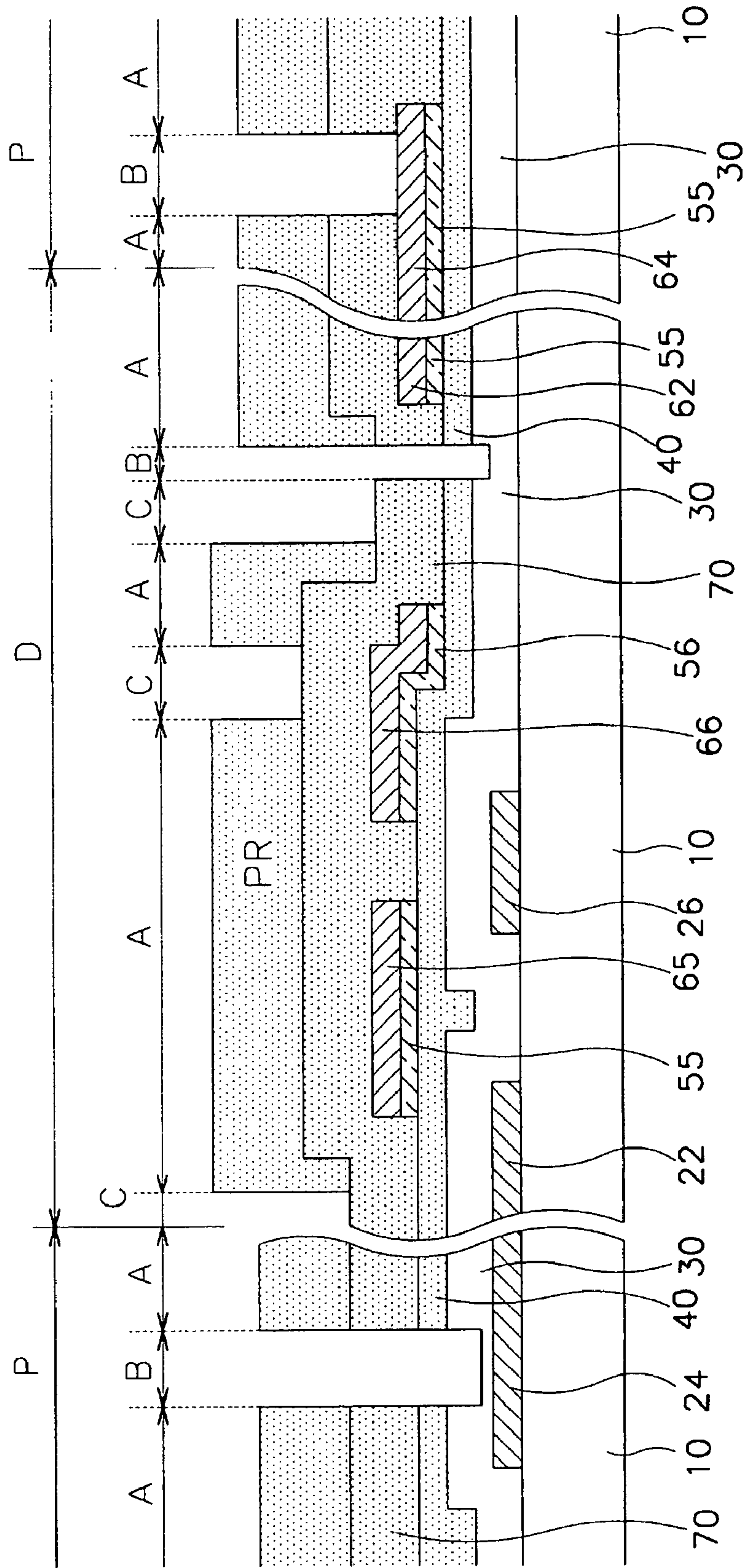

FIG. 34B

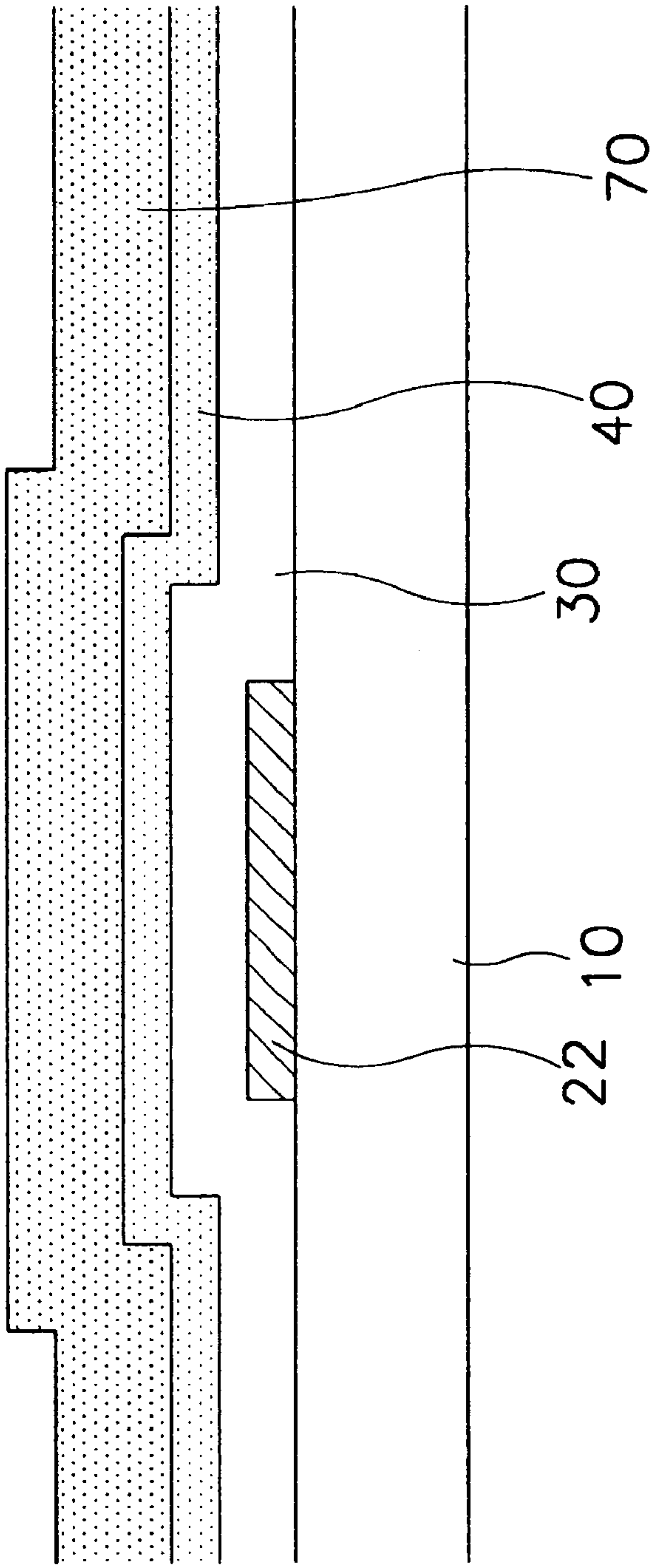

FIG. 35A

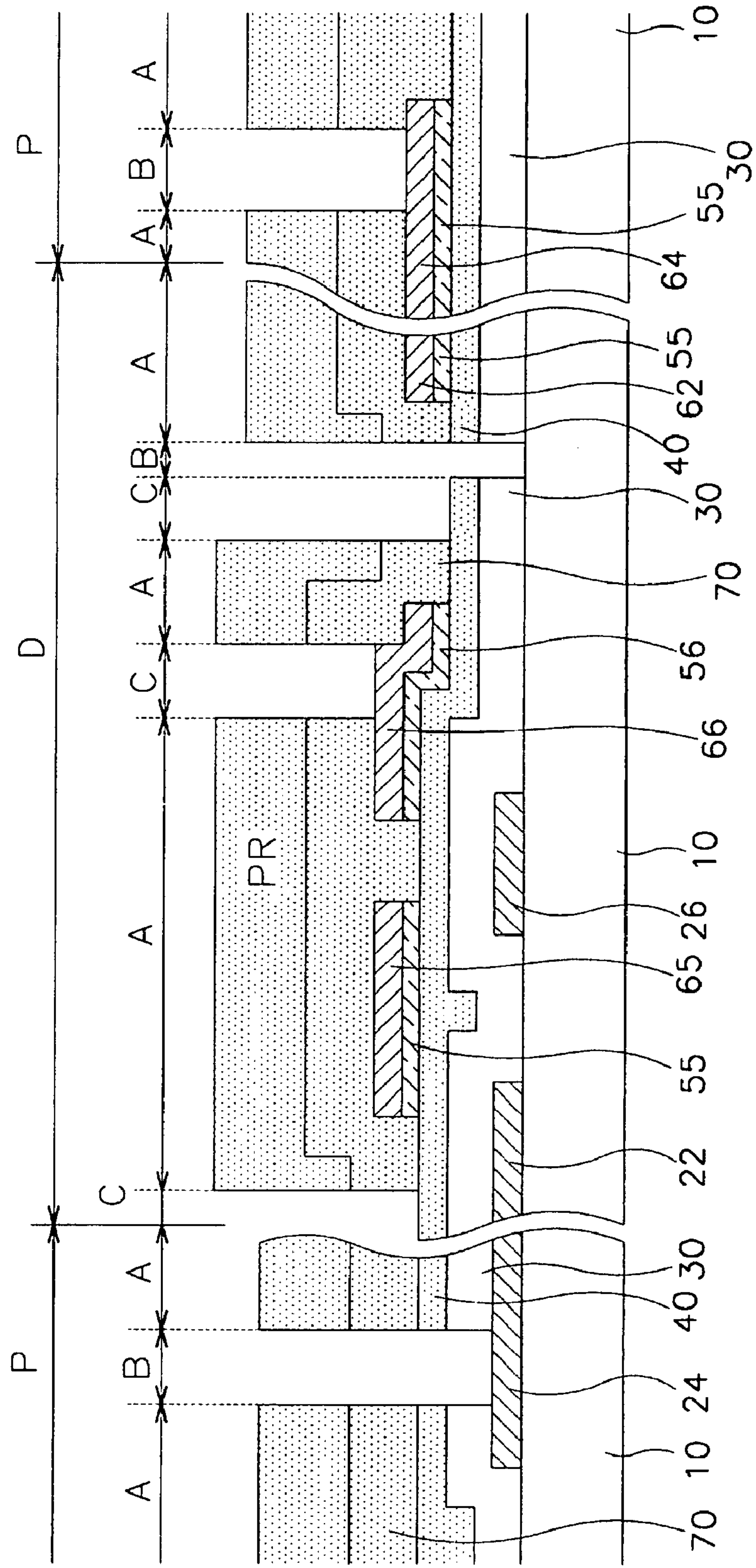

FIG. 35B

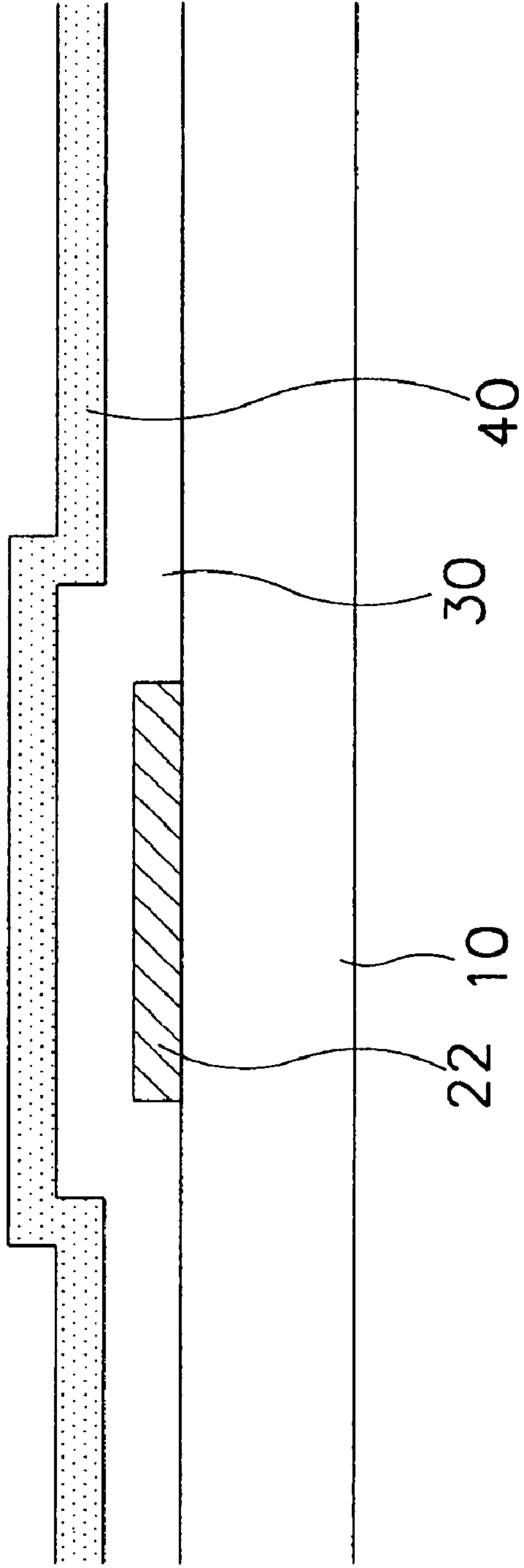

FIG. 36A

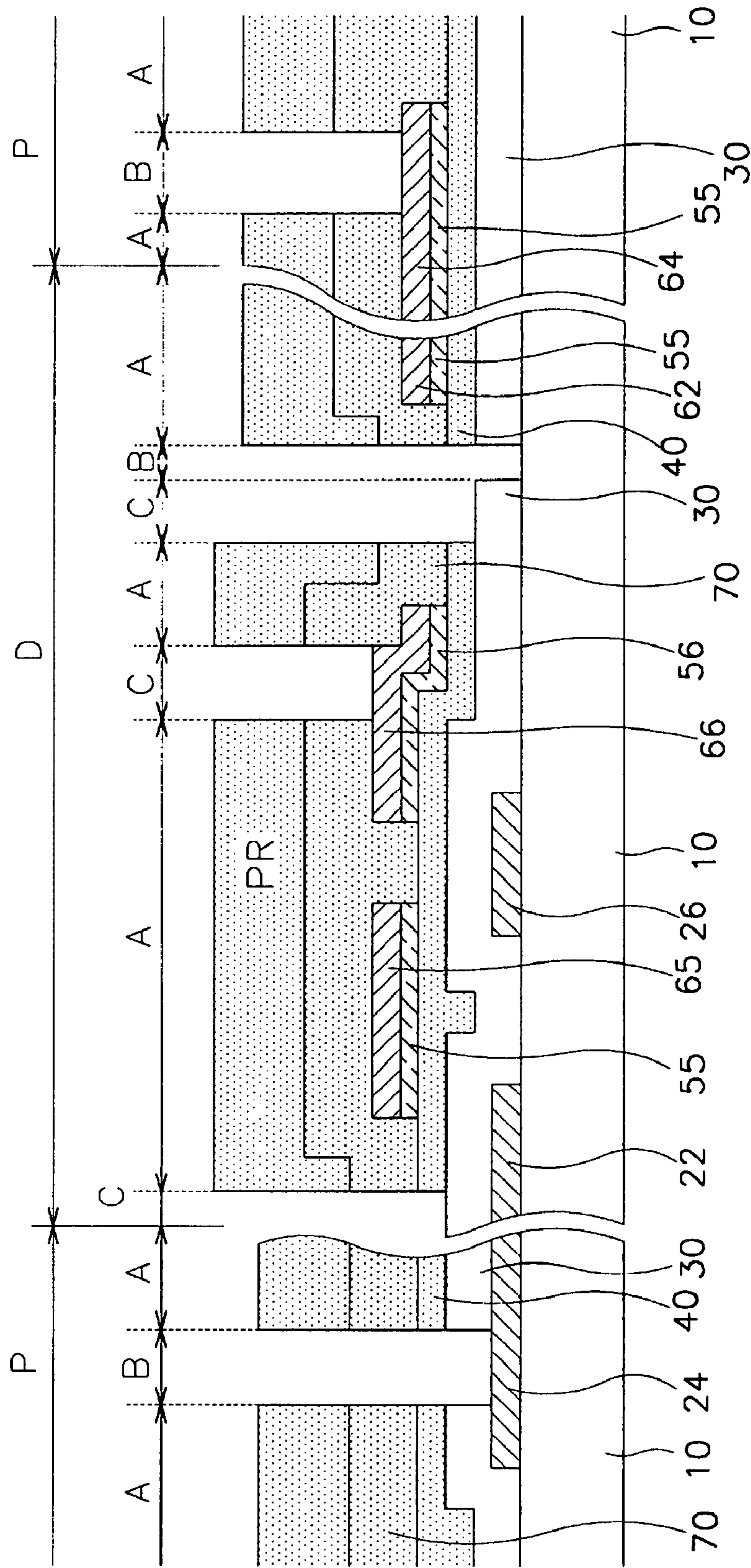

FIG. 36B

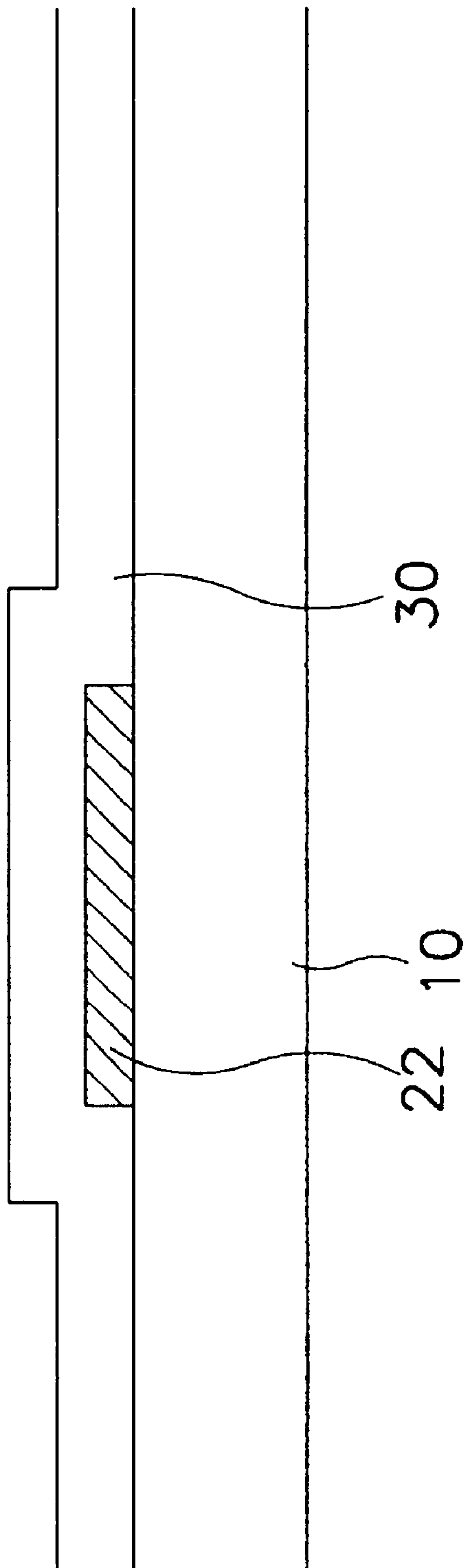

FIG. 37A

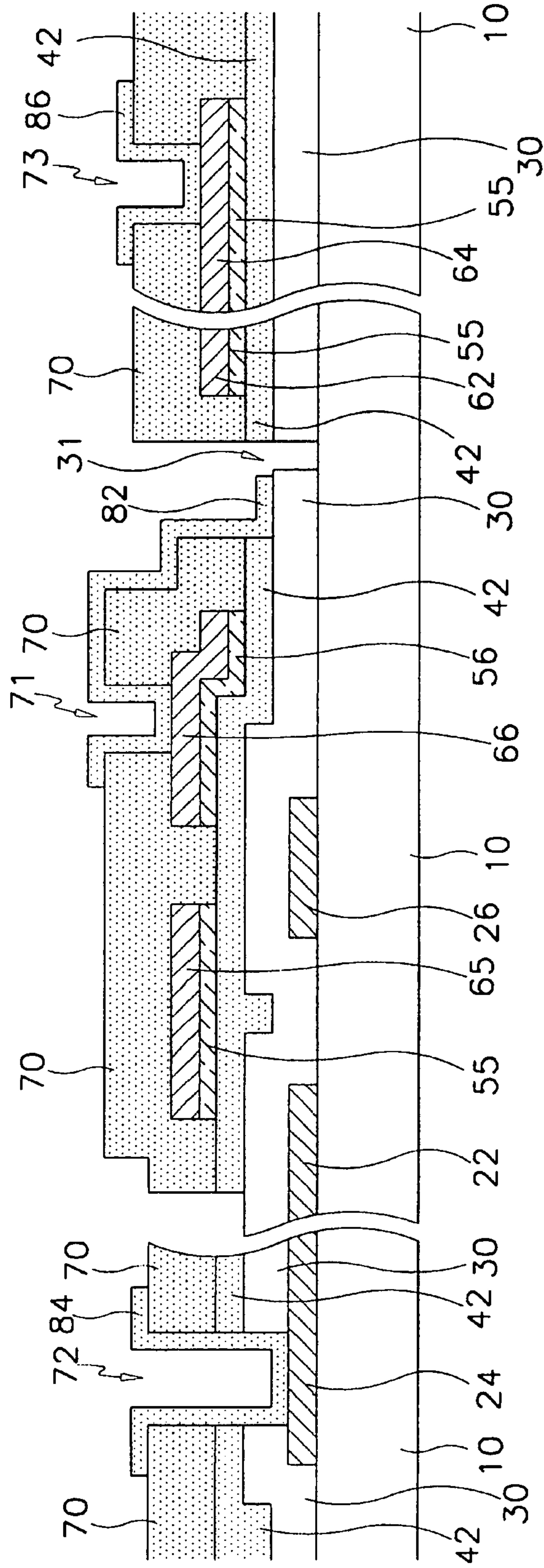

FIG. 37B

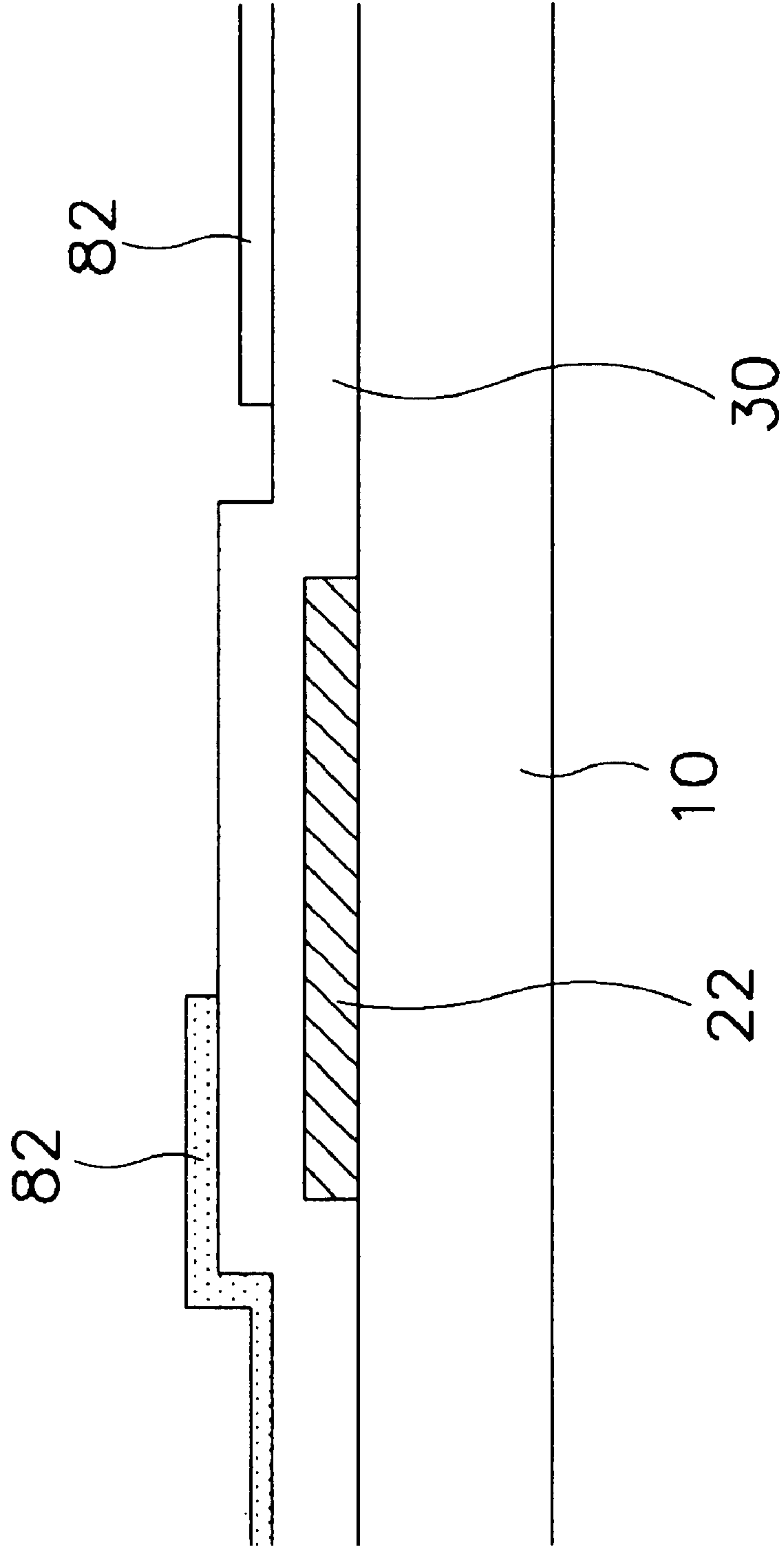

FIG. 38A

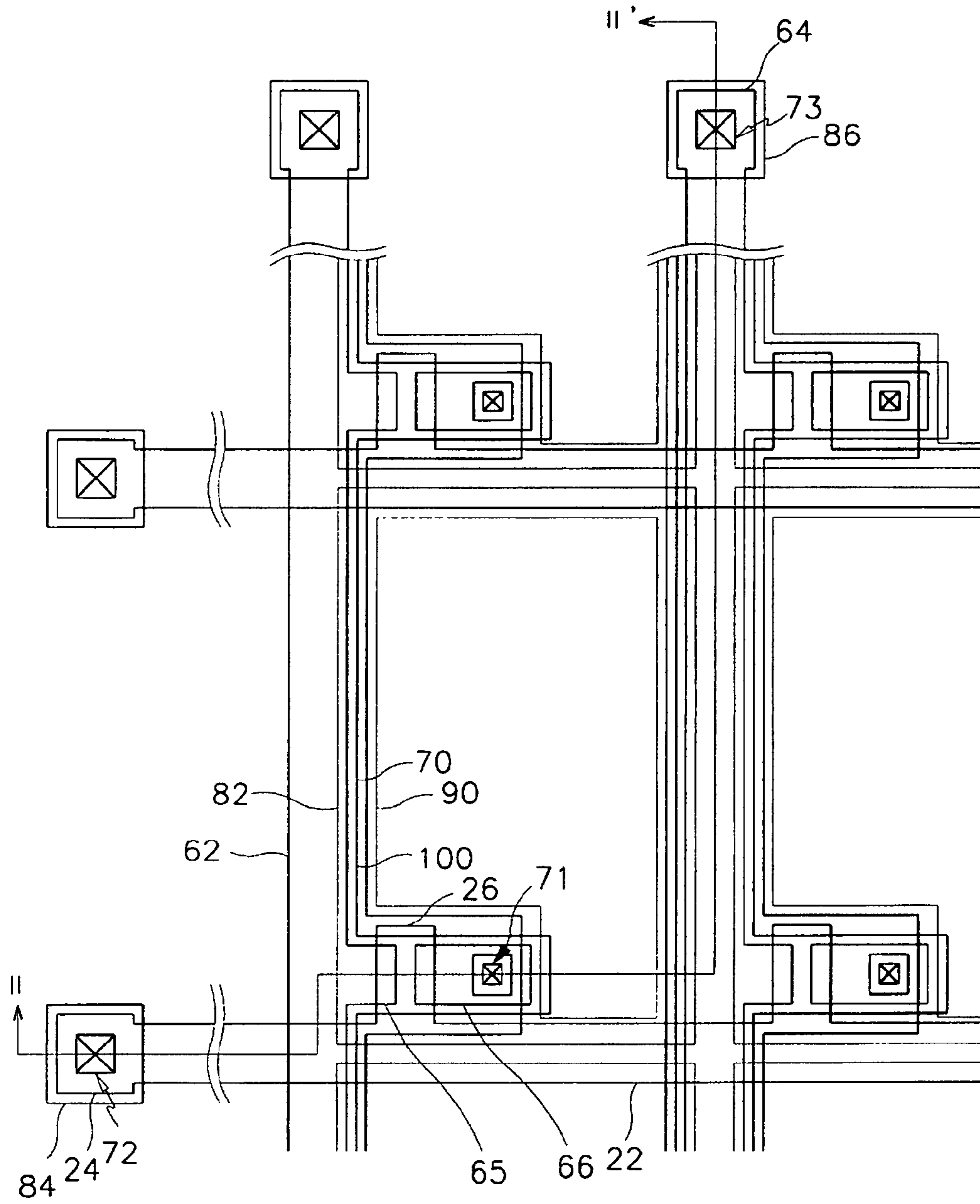

FIG. 38B

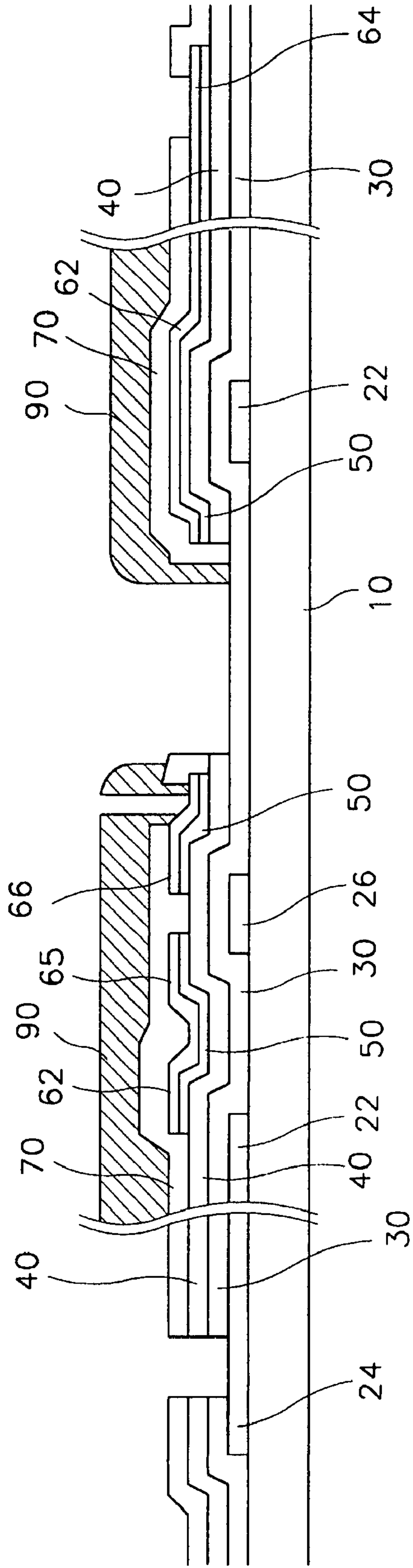

FIG. 39

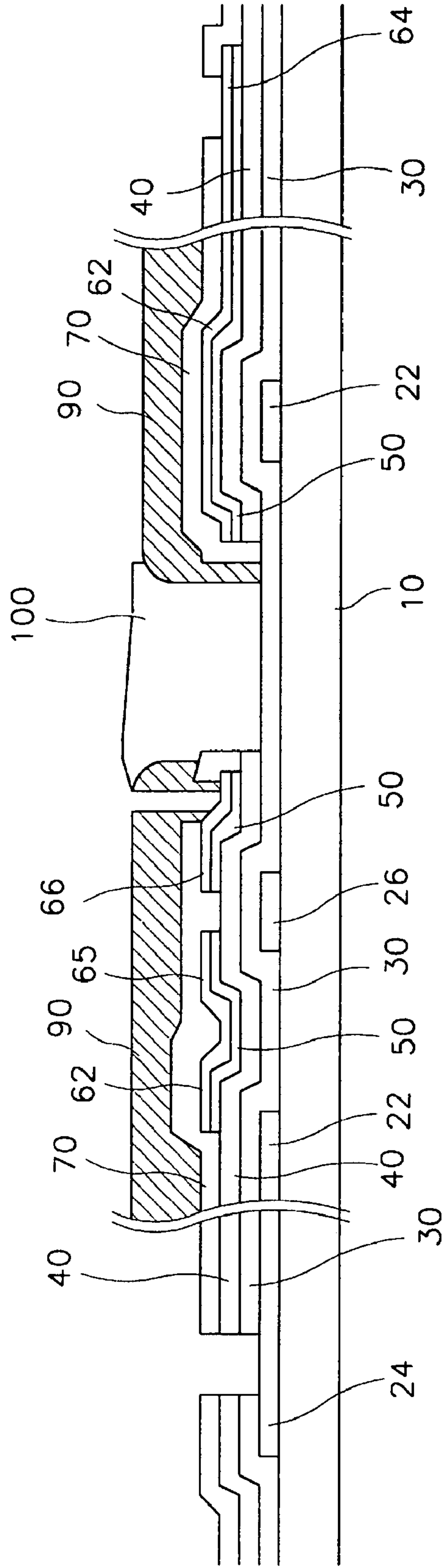

FIG. 40

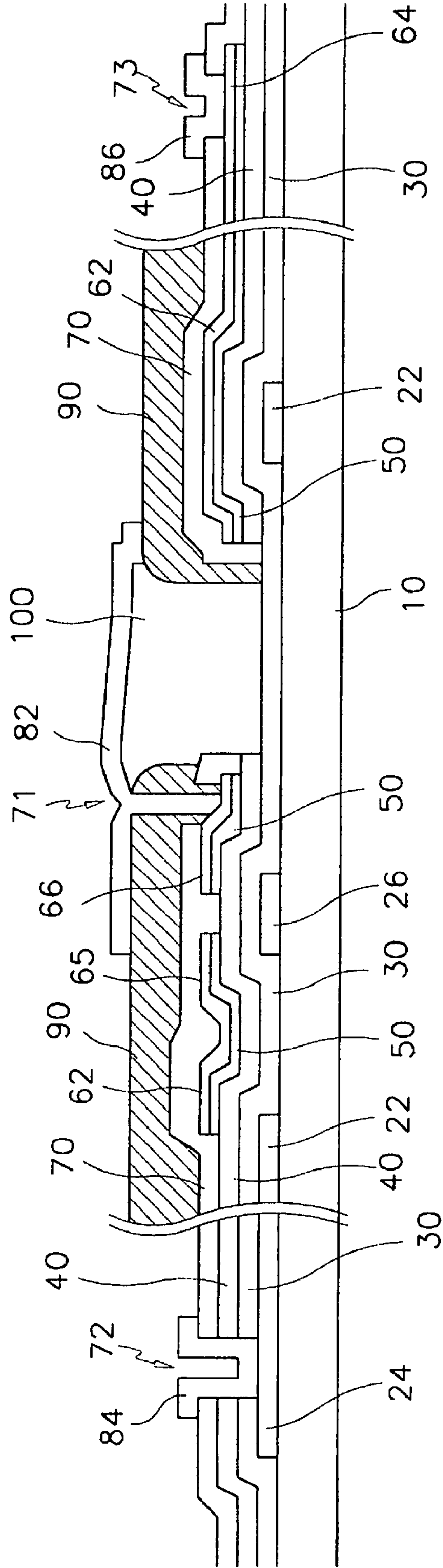

FIG. 41A

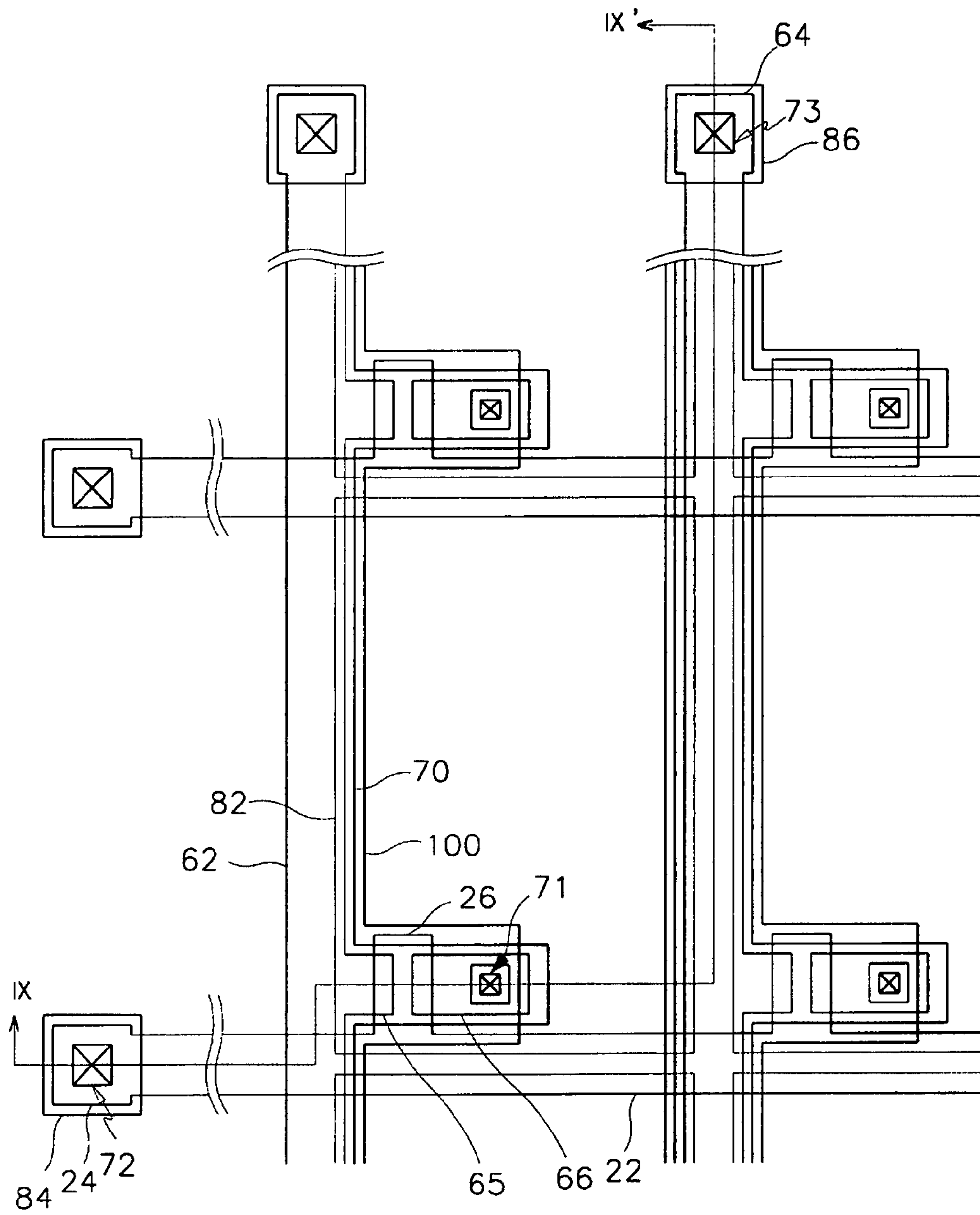

FIG. 41B

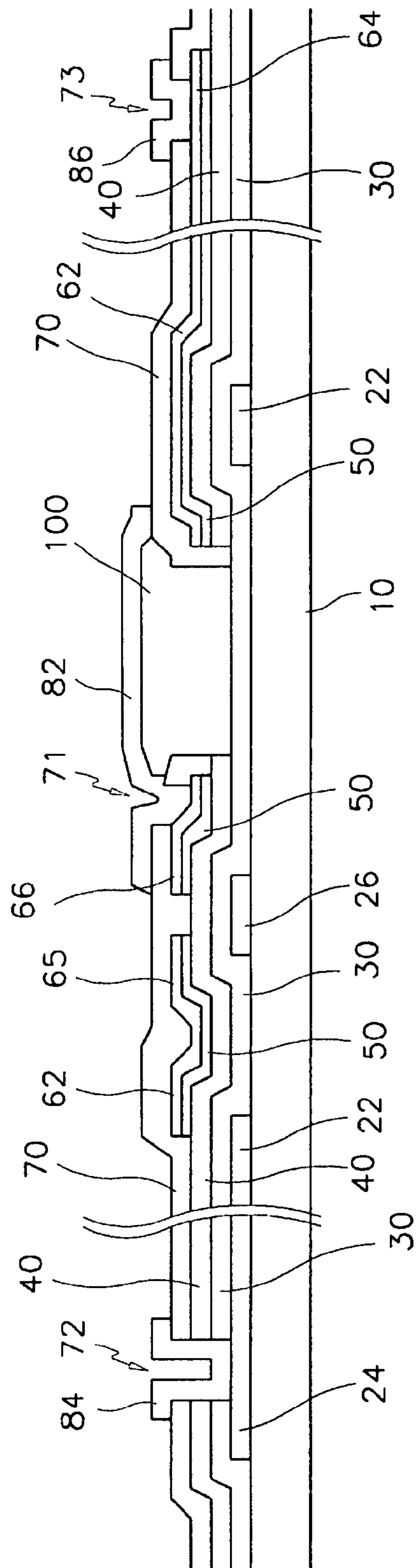

FIG. 42A

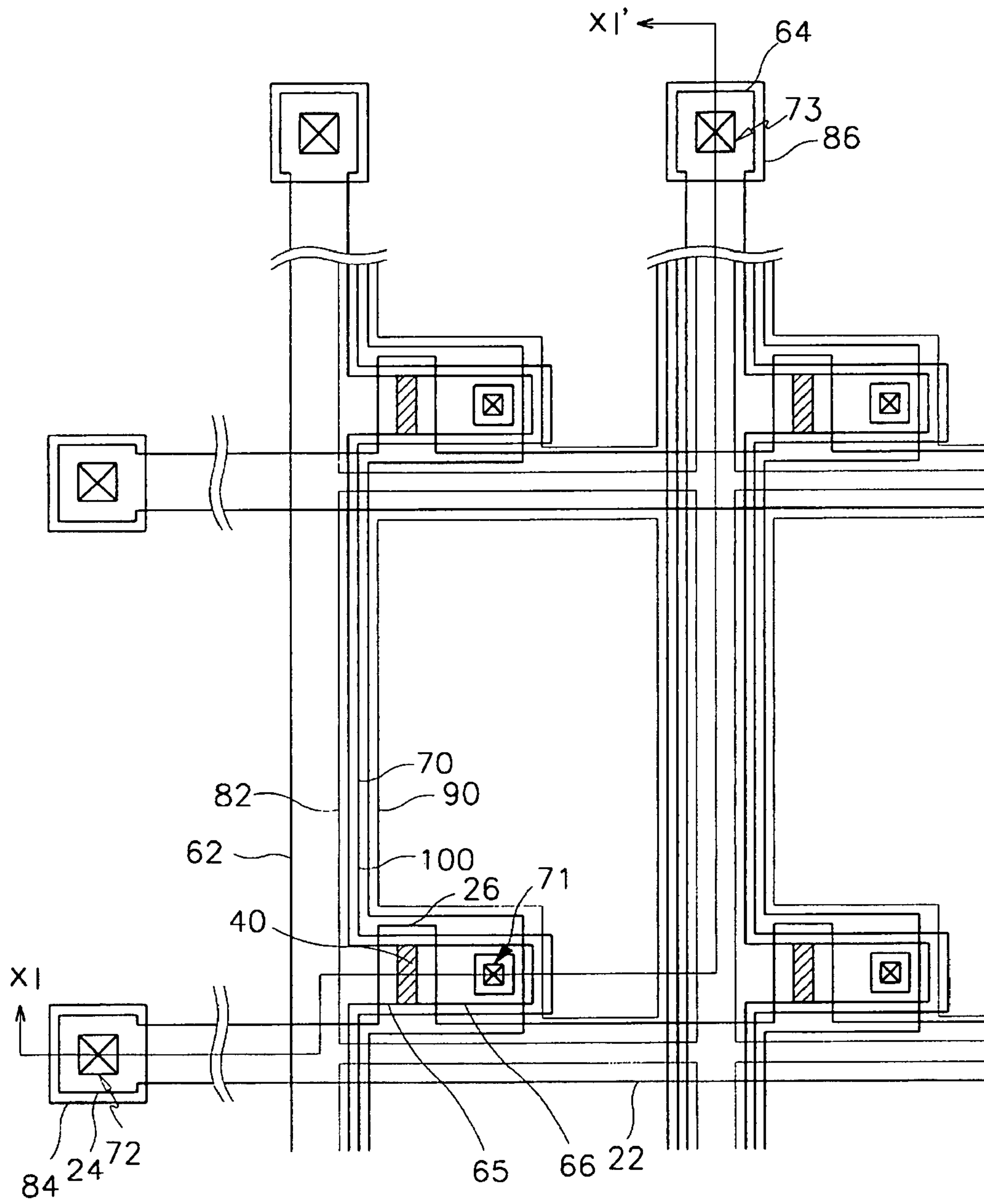

FIG. 42B

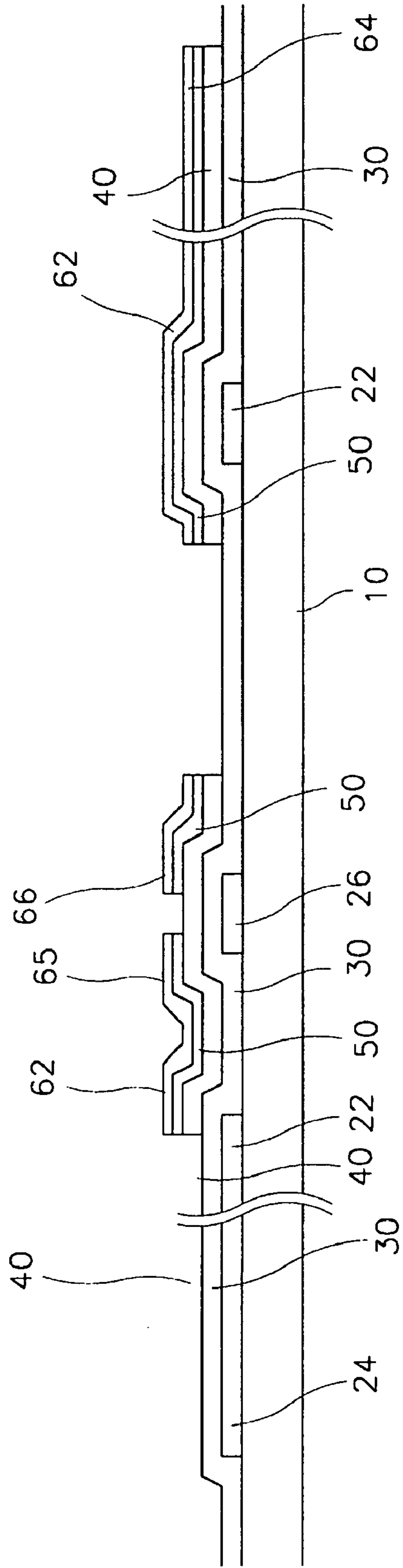

FIG. 43

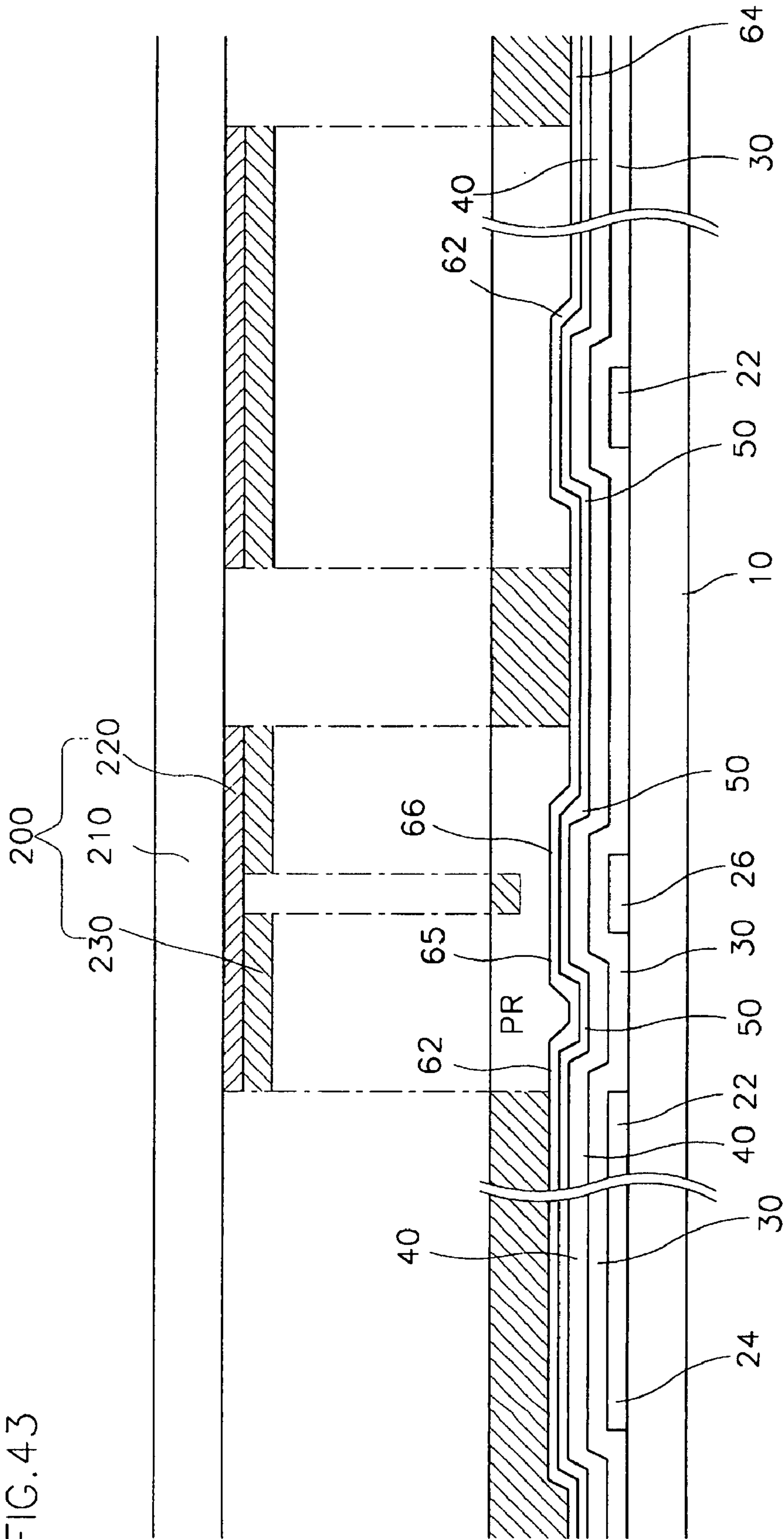

FIG. 44

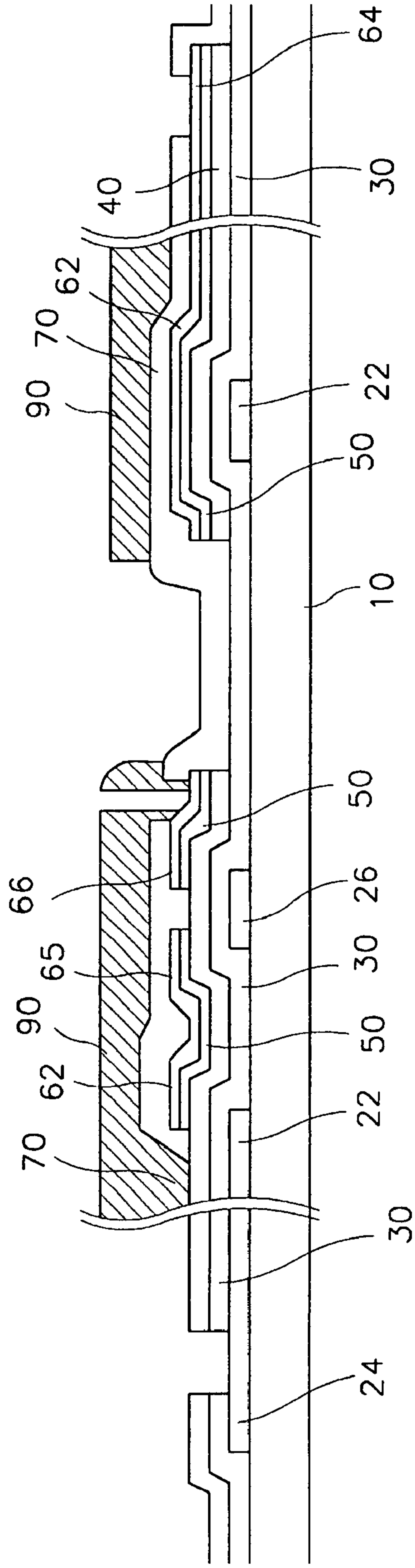

FIG. 45

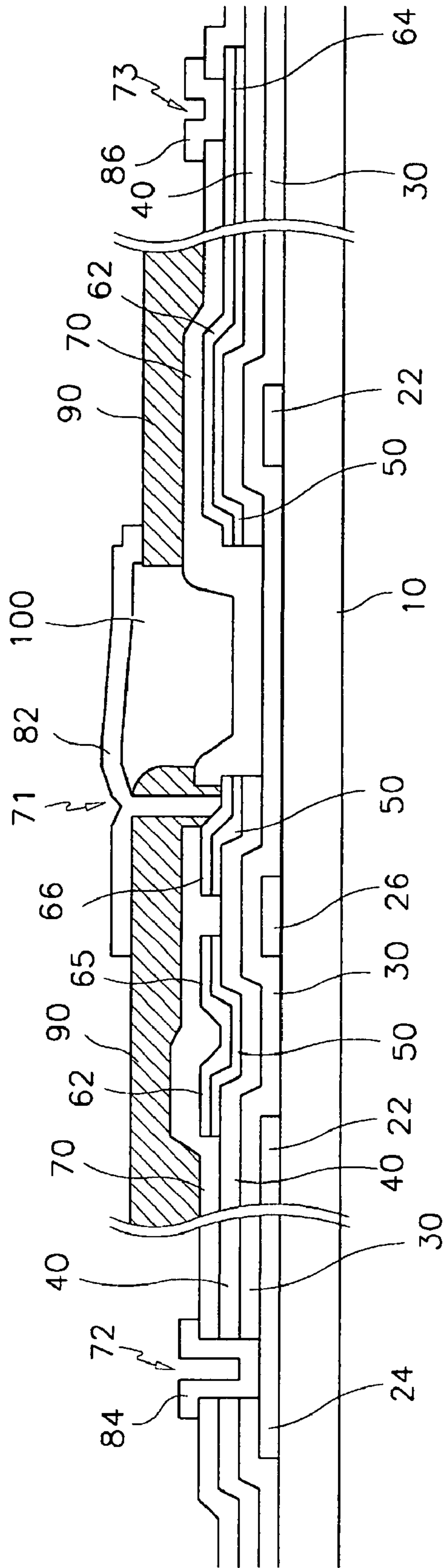

FIG. 46A

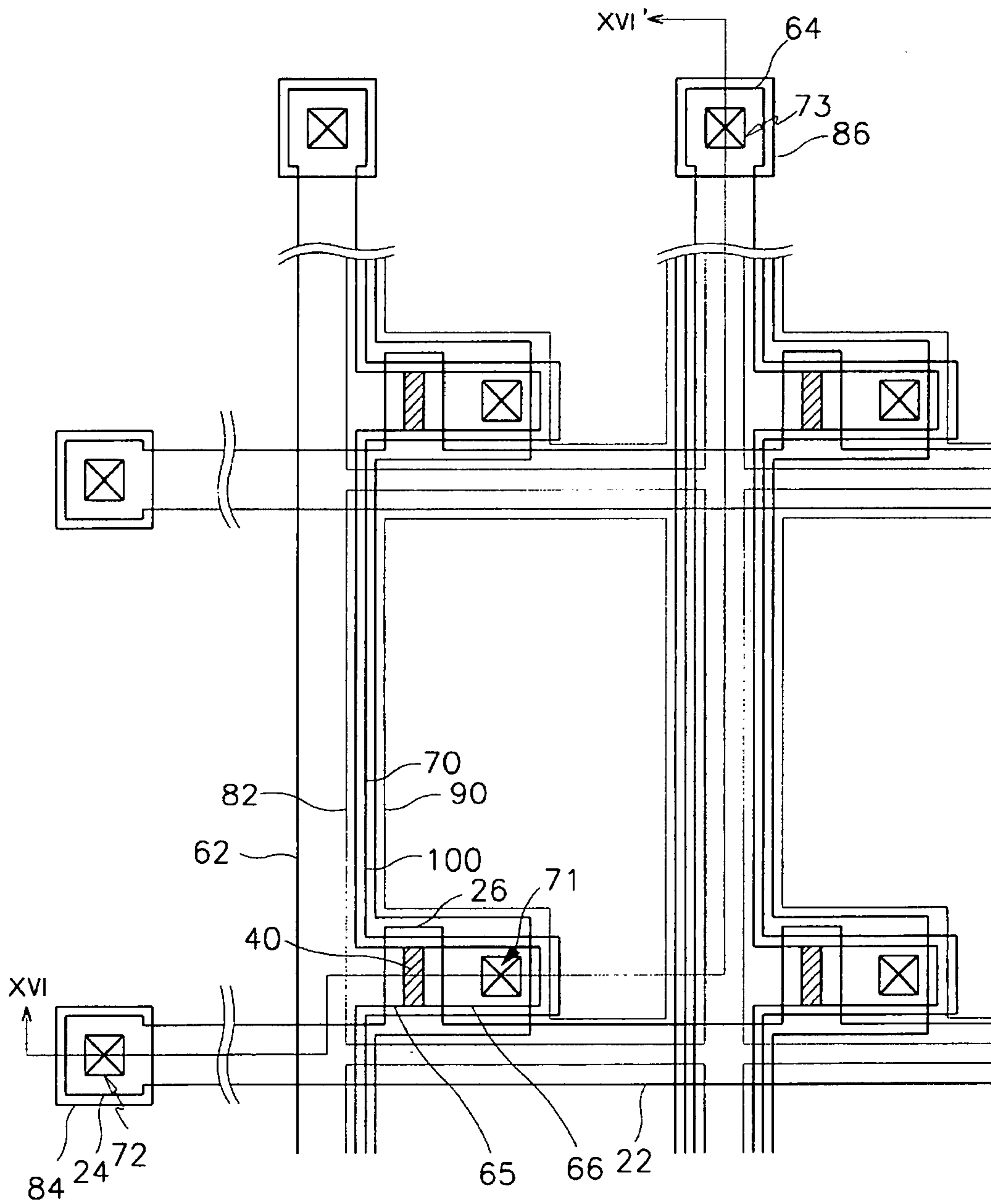

FIG. 46B

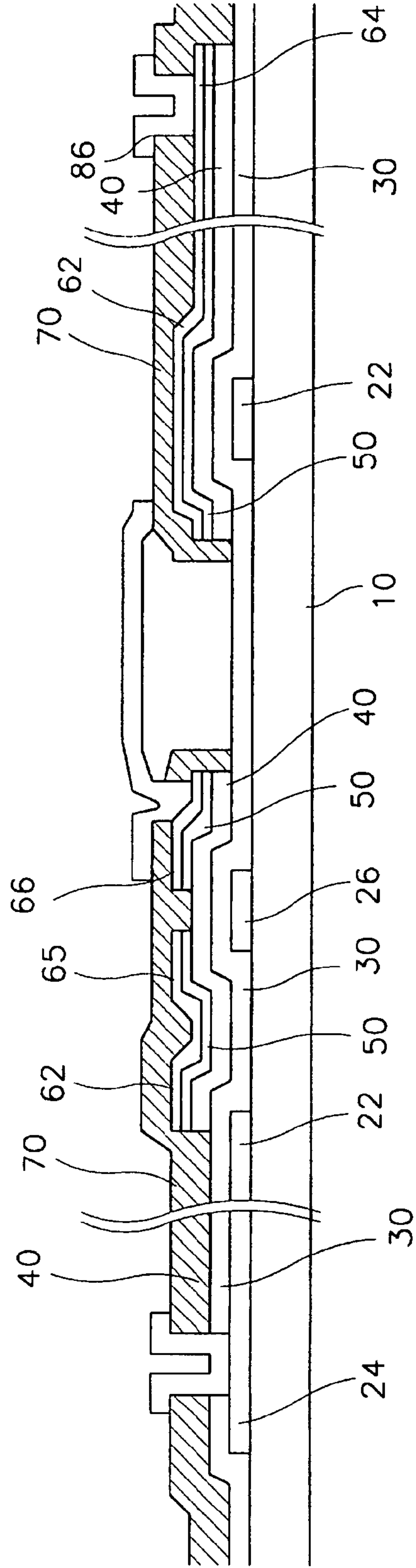

FIG. 47A

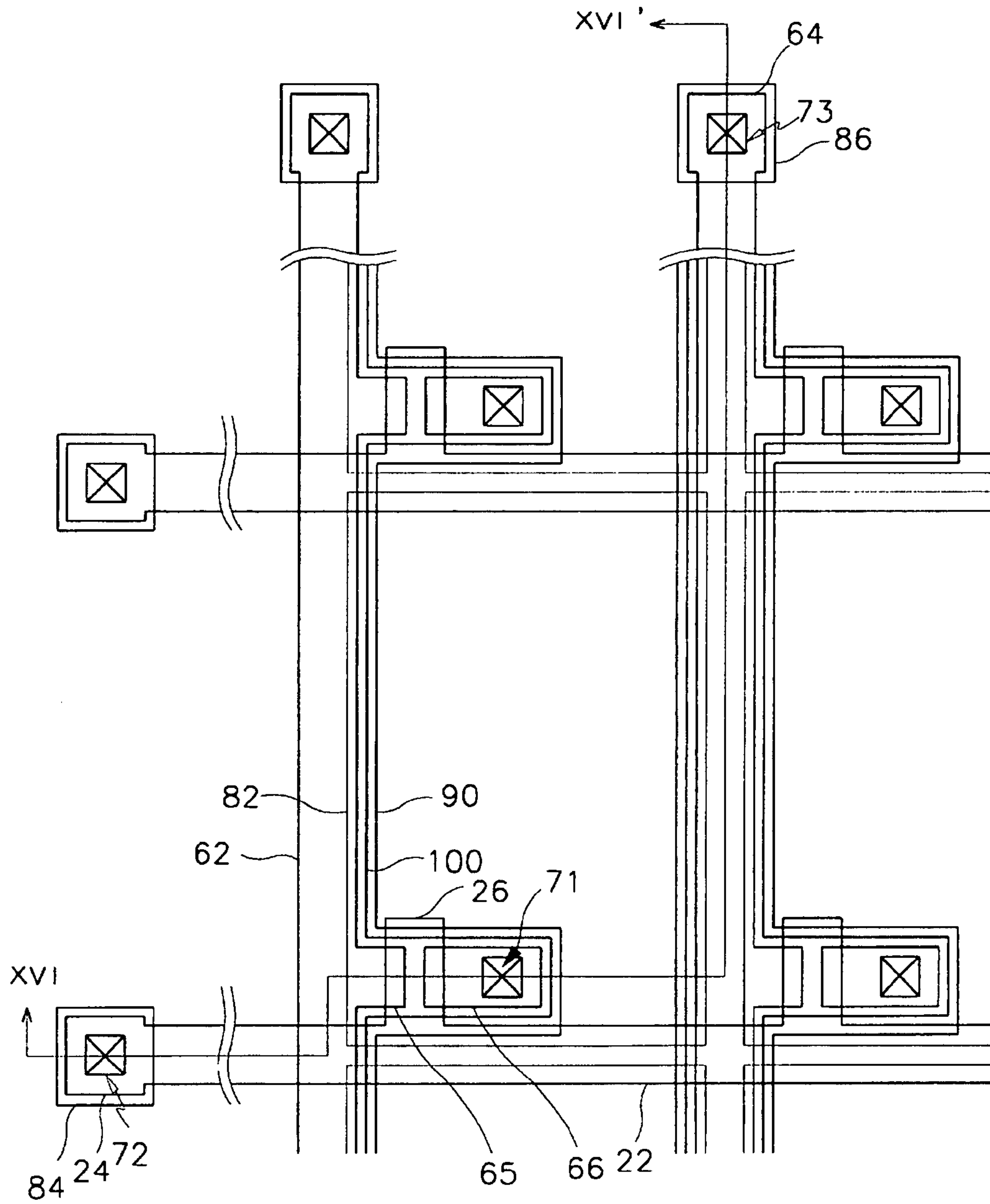

FIG. 47B

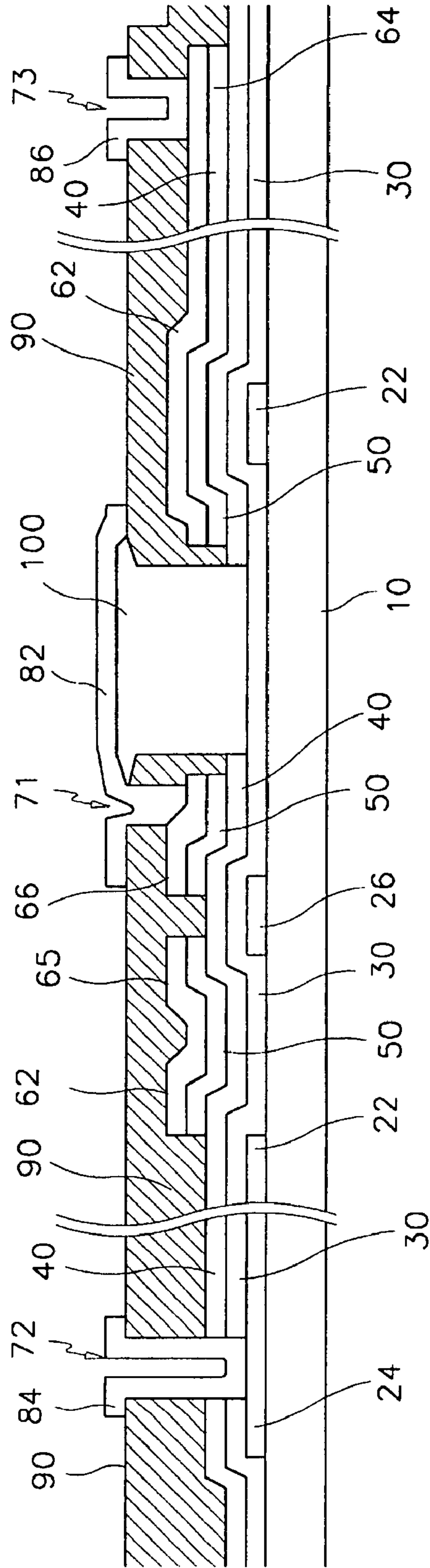

FIG. 48A

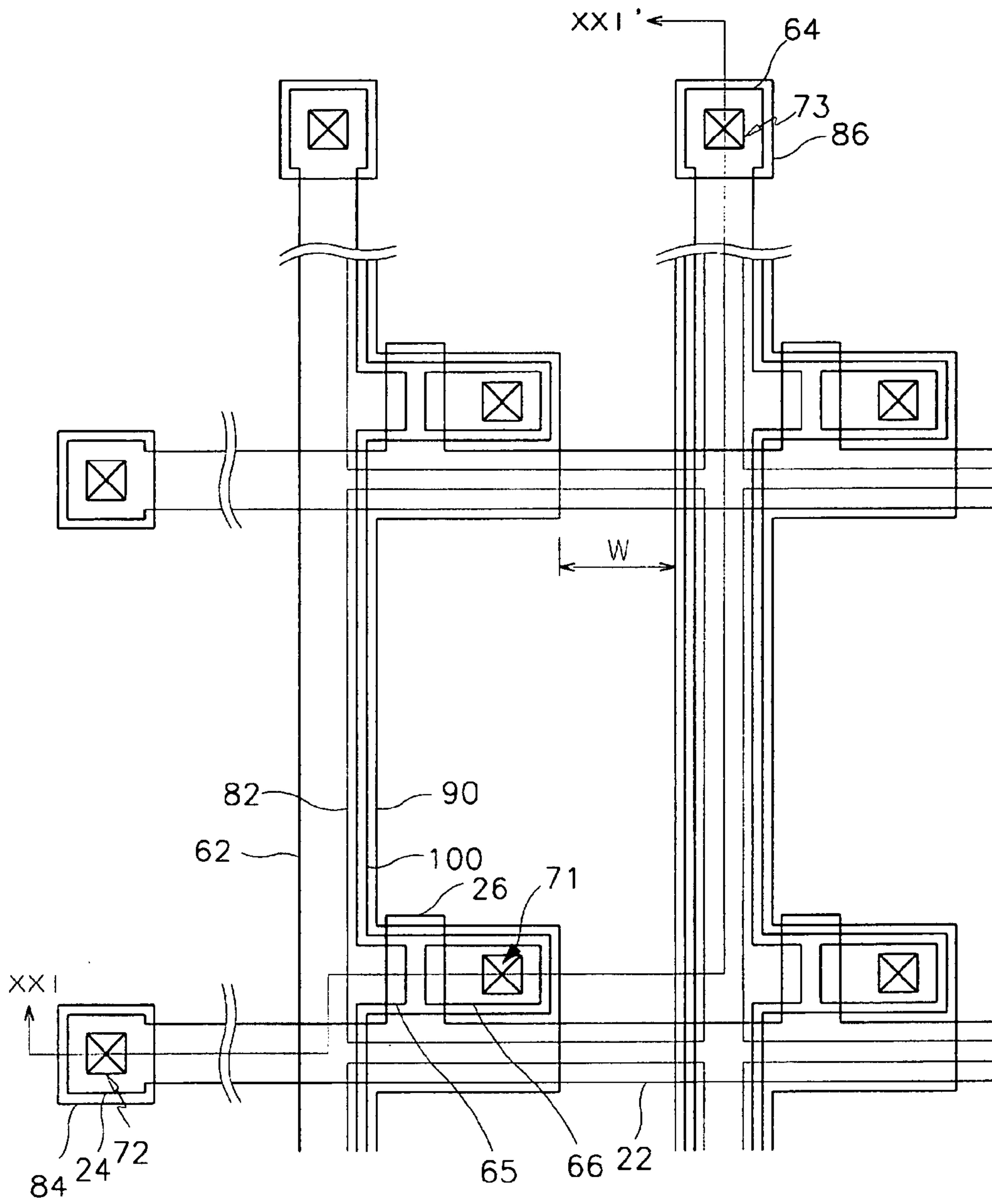
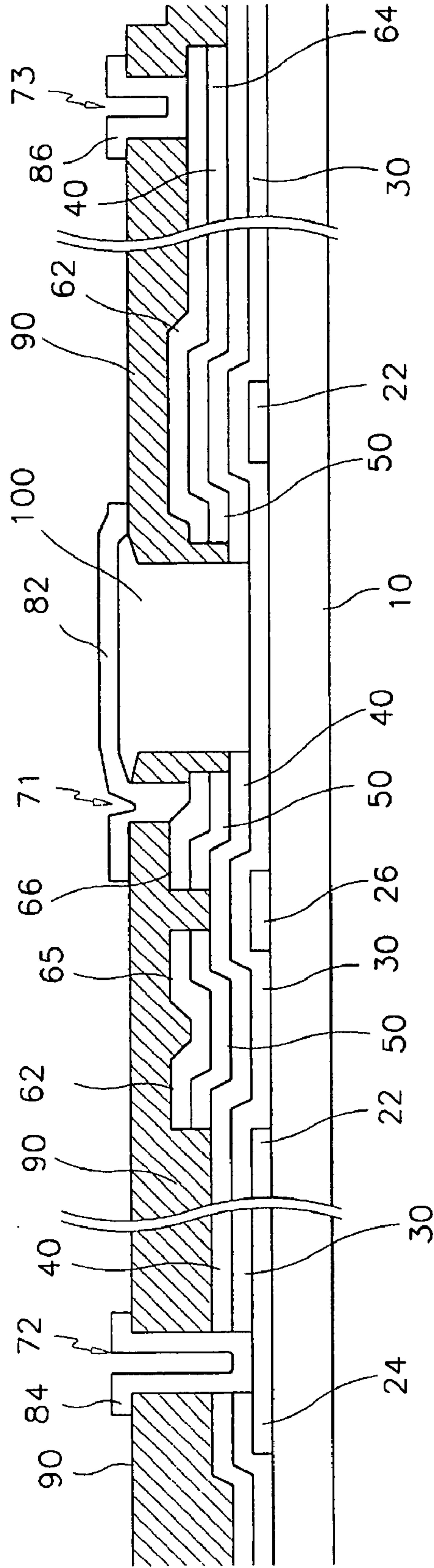

FIG. 48B



**THIN FILM TRANSISTOR ARRAY
SUBSTRATE FOR A LIQUID CRYSTAL
DISPLAY**

Matter enclosed in heavy brackets [] appears in the original patent but forms no part of this reissue specification; matter printed in italics indicates the additions made by reissue.

*CROSS-REFERENCE TO RELATED
APPLICATIONS*

This is a continuation reissue application of co-pending U.S. Reissue application Ser. No. 10/749,153 filed on Dec. 31, 2003, now U.S. Pat. No. RE40,162 based upon U.S. Pat. No. 6,380,559, issued on Apr. 30, 2002, which claims priority to Korean Patent Application Nos. 99-20515 filed on Jun. 3, 1999, 99-27140 filed on Jul. 6, 1999, 99-27548 filed on Jul. 8, 1999 and 99-29796 filed on Jul. 22, 1999, the disclosures of which are incorporated by reference herein in their entirety.

BACKGROUND OF THE INVENTION

(a) Field of the Invention

The present invention relates to a thin film transistor array (TFT) substrate for a liquid crystal display and a method for fabricating the same, and more particularly, to a method for fabricating a TFT array substrate of good performance in processing steps.

(b) Description of the Related Art

Generally, a liquid crystal display (LCD) is formed with two glass substrates, and a liquid crystal layer sandwiched between the substrates.

One of the substrates has a common electrode, a color filter and a black matrix, and the other substrate has pixel electrodes and thin film transistors (TFTs). The former substrate is usually called the "color filter substrate," and the latter substrate is usually called the "TFT array substrate."

The TFT array substrate is fabricated by forming a plurality of thin films on a glass substrate, and performing photolithography with respect to the thin films. In photolithography, many masks should be used for uniformly etching the thin films, and this involves complicated processing steps and increased production cost. Therefore, the number of masks becomes a critical factor in the fabrication efficiency of the TFT array substrate.

Furthermore, contact windows tend to be over-etched during the TFT formation, causing contact failure. Thus, it is required that stable and rigid contact between the desired electrodes should be ensured in the device fabrication.

On the other hand, the black matrix provided at the color filter substrate should be formed with a certain width considering the alignment margin for the color filter substrate joining the TFT array substrate. However, the larger black matrix reduces the aperture ratio. Therefore, the opening ratio of the black matrix should be also considered in fabricating the TFT array substrate.

SUMMARY OF THE INVENTION

It is an object of the present invention to provide a TFT array substrate for a liquid crystal display of good performance, and a method for fabricating the same with a reduced number of masks.

It is another object of the present invention to provide a method for fabricating a TFT array substrate that ensures suitable contacts between the electrode components.

It is still another object of the present invention to provide a method for fabricating a TFT array substrate with a suitable opening ratio.

These and other objects may be achieved by a TFT array substrate including a gate line assembly with gate lines proceeding in the horizontal direction, gate electrodes branched from the gate lines, and gate pads connected to end portions of the gate lines to receive scanning signals from the outside and transmit them to the gate lines. The gate line assembly may be formed with a single, double or triple layered structure. When the gate line assembly is formed with a double or triple layered structure, one layer is formed with a low resistance material while the other layer is formed with a material having good contact characteristics.

The gate line assembly is overlaid sequentially with a gate insulating layer, semiconductor patterns, and ohmic contact patterns.

A data line assembly is formed on the ohmic contact patterns with data lines proceeding in the vertical direction, data pads connected to end portions of the data lines to receive picture signals from the outside, and source electrodes branched from the data lines. The data line assembly further includes drain electrodes for the TFTs, and conductive patterns for the storage capacitors. The drain electrode is positioned opposite to the source electrode. With respect to the gate electrode while being separated from the source electrode. The conductive pattern is positioned above the gate line while overlapping the same. The conductive pattern is connected to a pixel electrode to form a storage capacitor. However, in case the overlapping of the pixel electrode and the gate line can give a sufficient amount of storage capacity, the conductive pattern may be omitted. The data line assembly may have a single, double or triple layered structure.

The semiconductor patterns have a shape similar to that of the data line assembly and the underlying ohmic contact patterns. The semiconductor layer extends to the peripheral portion of the substrate while covering the latter.

A passivation layer covers the data line, the data pad, the source electrode, the drain electrode, the semiconductor pattern, and the overlapping portions between the gate line and the data line.

Contact windows are formed at the passivation layer while exposing the drain electrode and the data pad. The contact window exposing the drain electrode may be extended toward the pixel area such that it can expose the borderline of the drain electrode completely. Another contact window is formed at the passivation layer while passing through the semiconductor pattern and the gate insulating layer to expose the gate pad to the outside.

The pixel electrode is formed on the gate insulating layer at the pixel area defined by the neighboring gate and data lines. The pixel electrode is electro-physically connected to the drain electrode through the contact window such that it receives picture signals from the TFT while making the required electrical field in association with a common electrode. The pixel electrode is extended over the conductive pattern, and electro-physically connected to the latter such that it serves as a storage capacitor together with the conductive pattern and the gate line.

A subsidiary gate pad and a subsidiary data pad are formed on the gate pad and the data pad, respectively. The subsidiary gate and data pads are formed together with the pixel electrode with the same material, and contact the gate and data pads, respectively.

An opening portion may be formed between the pixel electrode and the data line to prevent a possible short circuit thereof.

According to one aspect of the present invention, the steps of fabricating the TFT array substrate may be performed as follows.

A gate line assembly is first formed on a substrate by using a first mask. Then a gate insulating layer, a semiconductor layer, a contact layer, and first and second metal data line layers are deposited onto the substrate with the gate line assembly in a sequential manner. A data line assembly with a predetermined pattern is formed through etching the first and second metal data line layers by using a second mask. The contact layer is etched through the pattern of the data line assembly such that the contact layer has the same pattern as the data line assembly.

A passivation layer is then deposited onto the structured substrate such that the passivation layer covers the semiconductor layer and the data line assembly. A photoresist film is coated onto the passivation layer, and exposed to light by using a third mask. The photoresist film is then developed to thereby form a photoresist pattern partially differentiated in thickness.

A semiconductor pattern is formed by etching the passivation layer and the underlying semiconductor layer at the pixel area through the photoresist pattern. First and second contact windows are formed by etching the passivation layer and the underlying second layers of the drain electrode and the data pad. The third contact window is formed by etching the passivation layer and the underlying semiconductor layer and gate insulating layer, and the second layer of the gate pad.

After the photoresist pattern is removed, a pixel electrode is formed by using a fourth mask such that the pixel electrode is connected to the drain electrode through the first contact window.

The second metal gate or data line layer may be formed with aluminum or aluminum alloy, and the first layer with chrome, molybdenum, or molybdenum alloy. Subsidiary gate and data pads may be formed during the step of forming the pixel electrode such that they are connected to the first layers of the gate and data pads through the second and third contact windows. The pixel electrode as well as the subsidiary gate and data pads may be formed with indium tin oxide or indium zinc oxide.

The etching with respect to the second layers of the drain electrode, the gate pad and the data pad may be performed by using a wet-etching technique or a dry-etching technique.

The step of exposing the passivation layer positioned over the drain electrode and at the pixel area may be performed by removing the photoresist film over the passivation layer through oxygen-based ashing.

The third mask for forming the photoresist pattern may be provided with a transparent substrate, a first layer formed on the transparent substrate, and a second layer formed on the transparent substrate while overlapping with the first layer. The first layer has a light transmissivity lower than the transparent substrate, and the second layer has a light transmissivity different from those of the substrate and the first layer. The transparent substrate is established to have a first portion without the first and second layers, a second portion with only the first layer, and a third portion with both the first and second layers.

The transparent substrate has a light transmissivity of 90%, the first layer has a light transmissivity of 20-40%, and the second layer has a light transmissivity of 3% or less. The first and second layers may have a light transmissivity control pattern of slits or mosaics.

According to another aspect of the present invention, a black matrix and a color filter are formed on the structured substrate before the step of forming the pixel electrode.

After the semiconductor layer is etched to form a semiconductor pattern and the remaining photoresist film is removed, an organic black matrix layer is deposited onto the substrate, and etched through a fourth mask to thereby form a black matrix pattern. Alternatively, a black photoresist film may be used to form such a black matrix pattern.

A color filter is formed at the pixel area between the neighboring data lines, and at that point the formation of the pixel electrode and subsidiary gate and data pads is complete.

According to still another aspect of the present invention, the formation of the passivation layer is deferred after the formation of the semiconductor pattern.

A gate line assembly is first formed at the substrate by using a first mask. A gate insulating layer, a semiconductor layer, an ohmic contact layer, and a metal data line layer are then sequentially deposited onto the substrate. The metal data line layer, the ohmic contact layer and the semiconductor layer are etched through a second mask to thereby form the desired patterns with similar outlines except that the semiconductor pattern is present at the channel region between the source and drain electrodes.

A passivation layer is deposited onto the substrate with the data line assembly, and etched through a third mask to thereby form contact windows. An organic black matrix layer is then deposited onto the substrate, and etched through a fourth mask to thereby form a black matrix pattern. Thereafter, a color filter is formed, and the formation of a pixel electrode and subsidiary gate and data pads is complete.

In the above process, the black matrix pattern may perform the function of the passivation layer without forming the latter. Furthermore, it is also possible that the color filter is placed directly over the substrate and the gate line by removing the portion of the gate insulating layer positioned between the neighboring data lines.

BRIEF DESCRIPTION OF THE DRAWINGS

FIG. 1 is a schematic view illustrating a precursor substrate for fabricating a TFT array substrate according to a first preferred embodiment of the present invention where unit regions for the TFT array substrate are indicated.

FIG. 2 is a schematic view illustrating the TFT array substrate with circuit and line components according to the first preferred embodiment of the present invention.

FIG. 3 is an amplified view of the TFT array substrate shown in FIG. 2 at one pixel area.

FIGS. 4 and 5 are cross sectional views of the TFT array substrate shown in FIG. 3 taken along the IV-IV' line and the V-V' line, respectively.

FIG. 6A is a plan view of the TFT array substrate shown in FIG. 3 illustrating the step of forming a gate line assembly.

FIGS. 6B and 6C are cross sectional views of the TFT array substrate taken along the IVb-IVb' line and the IVc-IVc' line of FIG. 6A, respectively.

FIG. 7A is a plan view of the TFT array substrate shown in FIG. 3 illustrating the step of forming a data line assembly.

FIGS. 7B and 7C are cross sectional views of the TFT array substrate taken along the VIIb-VIIb' line and the VIIc-VIIc' line of FIG. 7A, respectively.

FIG. 8A is a plan view of the TFT array substrate shown in FIG. 3 illustrating the step of forming a semiconductor pattern and contact windows.

5

FIGS. 8B and 8C are cross sectional views of the TFT array substrate taken along the VIIIb-VIIIb' line and the VIIIc-VIIIc' line of FIG. 8A, respectively.

FIGS. 9A and 9B are cross sectional views of the TFT array substrate taken along the VIIIb-VIIIb' line and the VIIIc-VIIIc' line of FIG. 8A illustrating the step of exposing a photoresist film to light.

FIGS. 10A to 12 are cross sectional views of a mask for light-exposing the photoresist film shown in FIGS. 9A and 9B.

FIGS. 13A and 13B are cross sectional views of the TFT array substrate taken along the VIIIb-VIIIb' line and the VIIIc-VIIIc' line of FIG. 8A illustrating the step of developing the photoresist film.

FIGS. 14A and 14B are cross sectional views of the TFT array substrate taken along the VIIIb-VIIIb' line and the VIIIc-VIIIc' line of FIG. 8A illustrating the step of etching some portions of a passivation layer.

FIGS. 15A and 15B are cross sectional views of the TFT array substrate taken along the VIIIb-VIIIb' line and the VIIIc-VIIIc' line of FIG. 8A illustrating the step of ashing the etched portions of the passivation layer.

FIGS. 16A and 16B are cross sectional views of the TFT array substrate taken along the VIIIb-VIIIb' line and the VIIIc-VIIIc' line of FIG. 8A illustrating the step of etching other portions of the passivation layer.

FIGS. 17A and 17B are cross sectional views of the TFT array substrate taken along the VIIIb-VIIIb' line and the VIIIc-VIIIc' line of FIG. 8A illustrating the step of forming a semiconductor pattern.

FIGS. 18 to 23 are cross sectional views illustrating the steps of fabricating a TFT array substrate in a sequential manner according to a second preferred embodiment of the present invention.

FIGS. 24 to 29 are cross sectional views illustrating the steps of fabricating a TFT array substrate in a sequential manner according to a third preferred embodiment of the present invention.

FIG. 30A is a plan view of a TFT array substrate according to a fourth preferred embodiment of the present invention.

FIGS. 30B and 30C are cross sectional views of the TFT array substrate taken along the III-III' line and the IV-IV' line of FIG. 30A illustrating the step of exposing a photoresist film to light.

FIG. 31 is a cross sectional view of a mask for light-exposing the photoresist film shown in FIGS. 30B and 30C.

FIGS. 32A and 32B are cross sectional views of the TFT array substrate taken along the III-III' line and the IV-IV' line of FIG. 30A illustrating the step of developing the photoresist film.

FIGS. 33A and 33B are cross sectional views of the TFT array substrate taken along the line and the IV-IV' line of FIG. 30A illustrating the step of etching some portions of a passivation layer.

FIGS. 34A and 34B are cross sectional views of the TFT array substrate taken along the line and the IV-IV' line of FIG. 30A illustrating the step of ashing the etched portions of the passivation layer.

FIGS. 35A and 35B are cross sectional views of the TFT array substrate taken along the line III-III' line and the IV-IV' line of FIG. 30A illustrating the step of etching other portions of the passivation layer.

FIGS. 36A and 36B are cross sectional views of the TFT array substrate taken along the III-III' line and the IV-IV' line of FIG. 30A illustrating the step of forming a semiconductor pattern.

6

FIGS. 37A and 37B are cross sectional views of the TFT array substrate taken along the III-III' line and the IV-IV' line of FIG. 30A illustrating the step of forming a pixel electrode.

FIG. 38A is a plan view of a TFT array substrate according to a fifth preferred embodiment of the present invention.

FIG. 38B is a cross sectional view of the TFT array substrate taken along the II-II' line of FIG. 38A illustrating the step of forming a black matrix pattern.

FIG. 39 is a cross sectional view of the TFT array substrate taken along the II-II' line of FIG. 38A illustrating the step of forming a color filter.

FIG. 40 is a cross sectional view of the TFT array substrate taken along the II-II' line of FIG. 38A illustrating the step of forming a pixel electrode.

FIG. 41A is a plan view of a TFT array substrate according to a sixth preferred embodiment of the present invention.

FIG. 41B is a cross sectional view of the TFT array substrate taken along the IX-IX' line of FIG. 41A.

FIG. 42A is a plan view of a TFT array substrate according to a seventh preferred embodiment of the present invention.

FIG. 42B is a cross sectional view of the TFT array substrate taken along the XI-XI' line of FIG. 42A illustrating the step of forming a semiconductor pattern.

FIG. 43 is a cross sectional view of the TFT array substrate taken along the XI-XI' line of FIG. 42A specifically illustrating the step of forming the semiconductor pattern.

FIG. 44 is a cross sectional view of the TFT array substrate taken along the XI-XI' line of FIG. 42A illustrating the step of forming a black matrix pattern.

FIG. 45 is a cross sectional view of the TFT array substrate taken along the XI-XI' line of FIG. 42A illustrating the step of forming a color filter and a pixel electrode.

FIG. 46A is a plan view of a TFT array substrate according to an eighth preferred embodiment of the present invention.

FIG. 46B is a cross sectional view of the TFT array substrate taken along the XVI-XVI' line of FIG. 46A.

FIG. 47A is a plan view of a TFT array substrate according to a ninth preferred embodiment of the present invention.

FIG. 47B is a cross sectional view of the TFT array substrate taken along the XVI-XVI' line of FIG. 47A.

FIG. 48A is a plan view of a TFT array substrate according to a tenth preferred embodiment of the present invention.

FIG. 48B is a cross sectional view of the TFT array substrate taken along the XXI-XXI' line of FIG. 48A.

DETAILED DESCRIPTION OF THE PREFERRED EMBODIMENTS

Preferred embodiments of this invention will be explained with reference to the accompanying drawings.

First Preferred Embodiment

FIGS. 1 to 5 illustrate a TFT array substrate according to a first preferred embodiment of the present invention.

A plurality of panel regions for LCDs may be made at one insulating substrate at the same time. For example, as shown in FIG. 1, four panel regions 110, 120, 130 and 140 are made with display areas 111, 121, 131 and 141, and peripheral areas 112, 122, 132 and 142. TFTs, lines and pixel electrodes for the main components are repeatedly arranged at the display areas 111 to 141, whereas pads and other static electricity protection circuits for the components connected to the driving circuits are provided at the peripheral areas 112 to 142.

The display areas 111 to 141 and the peripheral areas 112 to 142 are divided into several regions, and each region is light-exposed by a stepper. A photoresist film coated the

substrate is exposed to light using identical or different masks per region. After the exposure, the photoresist film is wholly developed to form a photoresist pattern, and the underlying thin films are etched through the photoresist pattern to form thin film patterns. Such thin film patterns are repeated to form the TFT array substrate.

FIG. 2 is a schematic view outlining the TFT array substrate shown in FIG. 1 at one panel region where the display area is indicated by the long and short dashed line.

As shown in FIG. 2, a plurality of TFTs 3, pixel electrodes 82, gate lines 22 and data lines 62 electrically connected to the TFTs 3 are provided at the display area. Gate pads 24 placed at the end portions of the gate lines 22, and data pads 64 at the end portions of the data lines 62 are provided at the peripheral area. A gate line shorting bar 4 and a data line shorting bar 5 are further provided at the peripheral area to equipotentially interconnect the gate lines 22 and the data lines 62. neighboring gate and data line shorting bars 4 and 5 are electrically connected to each other via a shorting bar connection member 6. Completing the device fabrication, the shorting bars 4 and 5 are cut away along the dotted line 2. Contact windows 7 interconnect the shorting bar connection member 6 and the neighboring shorting bars 4 and 5.

FIG. 3 is an amplified view of the TFT array substrate shown in FIG. 2 at one pixel area, and FIGS. 4 and 5 are cross sectional view taken along the IV-IV' and V-V' lines, respectively.

First, a gate line assembly is formed on the insulating substrate 10. The gate line assembly includes gate lines 22 proceeding in the horizontal direction, gate electrodes 26 branched from the gate lines 22, and gate pads 24 connected to end portions of the gate lines 22 to receive scanning signals from the outside and transmit them to the gate lines 22.

The gate line assembly may be formed with a single, double or triple layered structure. When the gate line assembly is formed with a double or triple layered structure, one layer is preferably formed of a low resistance material and the other layer of a material having a good contact characteristic.

In this preferred embodiment, a gate line assembly with a double layered structure will be introduced. That is, the gate line assembly includes lower layers 221, 241 and 261, and upper layers 222, 242 and 262. The lower layers 221 to 261 are formed with a metallic material such as Cr, Mo, or Mo alloy that exhibits a good contact characteristic with respect to indium tin oxide (ITO) or indium zinc oxide (IZO). In contrast, the upper layers 222 to 262 are formed with a low resistance metallic material such as Al or Al alloy.

The gate line assembly is overlaid sequentially with a gate insulating layer 30, semiconductor patterns 42 and 48, and ohmic contact patterns 55, 56 and 58. The gate insulating layer 30 is formed with silicon nitride (SiN_x). The semiconductor patterns 42 and 48 are formed of hydrogenated amorphous silicon. The ohmic contact patterns 55, 56 and 58 are formed with amorphous silicon doped with n-type impurities such as phosphorus (P).

A data line assembly is formed on the ohmic contact patterns 55, 56 and 58. The data line assembly includes data lines 62 proceeding in the vertical direction, data pads 64 connected to end portions of the data lines 62 to receive picture signals from the outside, and source electrodes 65 branched from the data lines 62. The data line assembly further includes drain electrodes 66 for the TFTs, and conductive patterns 68 for the storage capacitors. The drain electrode 66 is positioned opposite to the source electrode 65 with respect to the gate electrode 26 and separated from the source electrode 65. The conductive pattern 68 is positioned above the gate line 22 while overlapping the same. The conductive pattern 68 is

connected to a pixel electrode 82 to form a storage capacitor. However, if the pixel electrode 82 and the gate line 22 can generate sufficient storage capacity, the conductive pattern 68 may be omitted.

In the following description, it is assumed that the conductive pattern 68 for the storage capacitor is present.

The data line assembly may have a single, double or triple layered structure. In this preferred embodiment, the double layered structure is used for the data line assembly. That is, the data line assembly includes lower layers 621, 641, 651, 661 and 681, and upper layers 622, 642, 652 and 662. The lower layers 621 to 681 are formed of a metallic material such as Cr, Mo or Mo alloy that exhibits a good contact characteristic with respect to ITO or IZO. The upper layers 622 to 662 are formed of a low resistance metallic material such as Al or Al alloy. As shown in FIG. 5, among the components of the data line assembly, only the conductive pattern 68 has a single layered structure with the lower layer 681.

The ohmic contact patterns 55, 56 and 58 reduce the contact resistance between the semiconductor patterns 42 and 48 and the data line assembly, and have the same shape as that of the data line assembly.

The semiconductor patterns 42 and 48 have a shape similar to that of the data line assembly and the underlying ohmic contact patterns 55, 56 and 58. Specifically, the semiconductor pattern 48 for the storage capacitor has the same shape as that of the conductive pattern 68 and the underlying ohmic contact pattern 58, while the shape of the semiconductor pattern 42 for the TFT differs from that of the data line assembly and the underlying ohmic contact patterns 55 and 56. That is, the source electrode 65 is separated from the drain electrode 66 at the channel region of the TFT, and the ohmic contact pattern 55 under the source electrode 65 is also separated from the ohmic contact pattern 56 under the drain electrode 66. In contrast, the semiconductor pattern 42 continuously proceeds at the channel region of the TFT. The semiconductor layer extends to the peripheral portion of the substrate 10 while covering the latter.

A passivation layer 70 covers the data line 62, the data pad 64, the source electrode 65, the drain electrode 66, the semiconductor pattern 42, and the overlapping portions between the gate line 22 and the data line 62.

Contact windows 71 and 73 are formed at the passivation layer 70 while exposing the drain electrode 66 and the data pad 64. The contact window 71 exposing the drain electrode 66 may be extended toward the pixel area such that it can expose the borderline of the drain electrode 66 completely. The Al-based upper layers 642 and 662 of the data pad 64 and the drain electrode 66 are removed such that the Cr-based lower layers 641 and 661 thereof are exposed through the contact windows 71 and 73. Another contact window 72 is formed at the passivation layer 70 while passing through the semiconductor pattern 42 and the gate insulating layer 30 to expose the gate pad 24 to the outside. The upper layer 242 of the gate pad 24 is removed such that the lower layer 241 thereof is exposed through the contact window 72.

The passivation layer 70 may be formed of an organic insulating material such as silicon nitride and acryl-based materials. The passivation layer 70 protects the channel portion of the semiconductor pattern 42 between the source and drain electrodes 65 and 66.

The aforementioned pixel electrode 82 is formed on the gate insulating layer 30 at the pixel area enclosed by the neighboring gate and data lines 22 and 62. The pixel electrode 82 is electro-physically connected to the underlayer 661 of the drain electrode 66 through the contact window 71 such that it receives picture signals from the TFT while making the

required electrical field in association with a common electrode. The pixel electrode **82** is formed of a transparent conductive material such as ITO or IZO. The pixel electrode **82** is extended over the conductive pattern **68**, and electro-physically connected to the latter such that it serves as a storage capacitor together with the conductive pattern **68** and the gate line **22**.

In the meantime, a supplemental gate pad **84** and a supplemental data pad **86** are formed on the gate pad **24** and the data pad **64**, respectively. The supplemental gate and data pads **84** and **86** are formed together with the pixel electrode **82** with the same material, and contact the Cr-based lower layers **241** and **641** of the gate and data pads **24** and **64**, respectively. The supplemental gate and data pads **84** and **86** strengthen the adhesion between the gate **24** and the data pad **64** and the external circuit devices and protect them. However they may be dispensed with.

The pixel electrode **82**, the supplemental gate and data pads **84** and **86** directly contact the Cr- or Mo-based lower layers **661**, **841** and **861** of the drain electrode **66**, and the gate and data pads **24** and **64**, which results in stable and good contacts between them.

In a reflection-type liquid crystal display, an opaque conductive material may be used for the pixel electrode **82** instead of ITO or IZO.

A method for fabricating the TFT array substrate according to the first preferred embodiment will be now explained with reference to FIGS. **3** to **5** and FIGS. **6A** to **17B**.

As shown in FIGS. **6A** to **6C**, a first metal gate line layer of chrome, molybdenum or molybdenum alloy is deposited onto a substrate **10** to a thickness of 500-1,500 Å. A second metal gate line layer of aluminum or aluminum alloy is then deposited onto the first gate line layer to a thickness of 1,000-4,000 Å. The first and second metal gate line layers are wet or dry-etched through a first mask so that a double-layered gate line assembly is formed at the substrate **10**. The gate line assembly includes a gate line **22** with lower layer **221** and upper layer **222**, a gate pad **24** with lower layer **241** and upper layer **242**, and a gate electrode **26** with lower layer **261** and upper layer **262**.

Thereafter, as shown in FIGS. **7A** to **7C**, a gate insulating layer **30** having a thickness of 1,500-5,000 Å, a semiconductor layer **40** having a thickness of 500-1,500 Å, and an ohmic contact layer **50** having a thickness of 300-600 Å are sequentially deposited onto the substrate **10** along with the gate line assembly through chemical vapor deposition. The gate insulating layer **30** is formed of silicon nitride, the semiconductor layer **40** of amorphous silicon (a-Si), and the ohmic contact layer **50** of doped amorphous silicon (n⁺a-Si).

A first metal data line layer of chrome, molybdenum or molybdenum alloy is then deposited onto the ohmic contact layer **50** to a thickness of 500-1,500 Å. A second metal data line layer of aluminum or aluminum alloy is deposited onto the first data line layer to a thickness of 500-4,000 Å. The first and second data line layers are etched through a second mask together with the underlying ohmic contact layer **50** to form a double-layered data line assembly. The data line assembly includes a data line **62** with lower layer **621** and upper layer **622**, a data pad **64** with lower layer **641** and upper layer **642**, a source electrode **65** with lower layer **651** and upper layer **652**, a drain electrode **66** with lower layer **661** and upper layer **662**, and a conductive pattern **68** with lower layer **681** and upper layer **682**. At this time, the ohmic contact layer **50** is also etched to form a first contact pattern **55** for the data line **62**, the data pad **64** and the source electrode **65**, a second contact pattern **56** for the drain electrode **66**, and a third

contact pattern **58** for the conductive pattern **68**. The conductive pattern **68** with the third contact pattern **58** may be omitted.

Thereafter, as shown in FIGS. **8A** to **8C**, a passivation layer **70** of silicon nitride is deposited onto the substrate **10** through chemical vapor deposition to a thickness of 3,000 Å. The passivation layer **70** is then etched through a third mask together with the underlying semiconductor layer **40** and gate insulating layer **30**. As a result, the passivation layer **70** and the upper layer **662** are removed from the drain electrode **66** to form a first contact window **71**. The passivation layer **70**, the semiconductor layer **40**, the gate insulating layer **30** and the upper layer **242** are removed from the gate pad **24** to form a second contact window **72**. The passivation layer **70** and the upper layer **642** are removed from the data pad **64** to form a third contact window **73**. The upper layer **682** is removed from the conductive pattern **68**. Furthermore, the passivation layer **70** and the semiconductor layer **40** at the pixel area between the neighboring data lines **62** are removed to form the channel region only at the required portion.

The etching process using the third mask will be now described in detail.

A photoresist film PR having a thickness of 5,000-30,000 Å is coated onto the passivation layer **70**, and exposed to light through the third mask. As shown in FIGS. **9A** and **9B**, the light exposure at the display area D is different from the light exposure at the peripheral area P. That is, the exposed portion C of the photoresist film PR at the display area D reacts to the light such that the molecules thereof are partially resolved to a predetermined depth from the surface while leaving the molecules thereunder unresolved. In contrast, the exposed portion B of the photoresist film PR at the peripheral area P reacts to the light such that the molecules thereof are completely resolved to the bottom.

In order to perform such a differential light exposure, the light transmissivity of the third mask corresponding to the display area D and the peripheral area P of the photoresist film PR should be controlled appropriately. Three types of techniques will be here introduced.

FIGS. **10A** to **12** illustrate possible structures of the third mask for etching the passivation layer **70** along with the underlying layers.

First, separate masks can be used for the third mask to perform the masking operation with respect to the display area D and the peripheral area P of the photoresist film PR, respectively.

As shown in FIGS. **10A** and **10B**, a mask **300** for the display area D and a mask **400** for the peripheral area P are formed with substrates **310** and **410**, chrome-based opaque films **320** and **420** formed on the substrates **310** and **410**, and semitransparent pellicles **330** and **430** covering the substrates **310** and **410** with the opaque films **320** and **420**. It is preferable that the light transmissivity of the opaque films **320** and **420** be 3% or less, the light transmissivity of the pellicle **430** of the mask **400** for the peripheral area P to be 90% or more, and the pellicle **330** of the mask **300** for the display area D to be 20-40% that is in the range of 20-60% of the light transmissivity of the pellicle **430** for the peripheral area P.

Meanwhile, patterns of slit or lattice with an opening width of about 2.5 μm that is smaller than the resolution capability of the light source for exposure may be formed as a replacement for the semitransparent pellicle **330** for the display area D.

Alternatively, as shown in FIGS. **11A** and **11B**, a chrome-based thin film **350** with a thickness of 100-300 Å covers the entire surface of the mask **300** for the display area D while being positioned under the opaque film **320**, whereas such a

chrome-based thin film is absent at the mask **400** for the peripheral area P. In this case, the pellicle **340** of the mask **300** for the display area D may have the same light transmissivity as that of the pellicle **430** of the mask **400** for the peripheral area P.

Of course, the above two techniques may be used together in a suitable application.

The above two types of masks can be applied for use in partitioned exposure with a stepper, and separately perform the masking operation with respect to the display area D and the peripheral area P. The thickness of the target film can be also controlled by making the light exposure period different depending on the display area D and the peripheral area P.

On the other hand, only one mask can be used for the light exposure with respect to the display and the peripheral areas D and P at the same time while controlling the amount of light applied thereto. FIG. **12** illustrates the structure of such a mask **500**.

As shown in FIG. **12**, a light transmissivity control film **550** is formed on a substrate **510** for the mask **500**, and an opaque film **520** is formed on the light transmissivity control film **550**. Whereas the light transmissivity control film **550** for the display area D is formed on the entire surface of the substrate **510**, the light transmissivity control film **550** for the peripheral area P is formed only under the opaque film **520**. That is, two or more patterns with different thickness are formed on the substrate **510**. Of course, such a light transmissivity control film may be formed on the entire surface of the substrate **510** both at the display and the peripheral areas D and P. In this case, the light transmissivity of the light transmissivity control film **550** for the peripheral area P should be established to be higher than that of the light transmissivity control film **550** for the display area D.

In the fabrication process of the mask **500**, a light transmissivity control film **550**, and an opaque film **520** with an etching ratio different from that of the light transmissivity control film **550** are sequentially deposited onto the substrate **510**. A photoresist film is coated on the entire surface of the substrate **510** with the light transmissivity film **550** and the opaque film **520**, exposed to light, and developed to form a photoresist pattern. The opaque layer **520** is then etched by using the photoresist pattern for the mask. The photoresist pattern is then removed, and a second photoresist pattern is formed while exposing the portions of the light transmissivity film **550** corresponding to the contact windows at the peripheral area P to the outside. The light transmissivity film **550** is then etched by using the second photoresist pattern for a mask. A semitransparent pellicle **530** is finally formed on the substrate **510** with the patterns of the light transmissivity film **550** and the opaque layer **520**.

Meanwhile, the portions of the photoresist film PR with the underlying metal gate or data line assembly may be applied with a larger amount of light due to the light reflected against the metallic component. Therefore, in order to prevent such a problem, a new layer for intercepting the reflected light, for example a colored photoresist film PR, may be introduced.

As shown in FIGS. **13A** and **13B**, when the photoresist film PR exposed through the third mask is developed, a photoresist pattern PR results. That is, some portions B of the photoresist film at the peripheral area P over the gate and data pads **24** and **64** are completely removed, and some portions C of the photoresist film at the display area D over the drain electrode **66** and the pixel area are partially removed with a resulting small thickness. The remaining portions of the photoresist film at the display and the peripheral areas D and P are left with a relatively large thickness. In this process, as shown in FIG.

13B, the photoresist film having a small thickness may be formed over the conductive pattern **68**.

The thickness of the thin photoresist film is preferably in the range of 350-10,000 Å that is one fourth to one seventh of the initial thickness, and more preferably in the range of 1,000-6,000 Å. For instance, the initial thickness of the photoresist film may be established to be 25,000-30,000 Å, and the thickness of the thin photoresist film to be 3,000-5,000 Å by controlling the light transmissivity of the mask at the display area D to 30%. However, since the resulting thickness is determined in accordance with the processing conditions, the pellicle of the mask, the thickness of the chrome-based film, and the light transmissivity of the light transmissivity control film, the exposing time should be controlled depending upon such processing conditions.

Alternatively, such a thin photoresist film may be formed by using a common processing technique including the steps of exposing and developing the photoresist film, and then performing the following operation, whereby the photoresist pattern PR and the underlying passivation layer **70**, semiconductor layer **40** and gate insulating layer **30** are etched by using a dry etching technique, passivation

In the etching process, the A portion of the photoresist pattern PR should be partially left, the passivation layer **70**, semiconductor layer **40** and gate insulating layer **30** positioned under the B portion of the photoresist pattern PR should be removed, and the passivation layer **70** and semiconductor layer **40** under the C portion of the photoresist pattern PR should be removed, while leaving the gate insulating layer **30**.

For this purpose, a dry etching technique that is capable of etching the photoresist pattern PR and the underlying layers at the same time may be used.

Alternatively, in order to prevent only partial removal of the semiconductor layer **40** over the gate insulating layer **30** due to the non-uniform thickness of the resulting photoresist film, the photoresist pattern PR and the underlying layers can be etched through several etching steps as described below.

As shown in FIGS. **14A** and **14B**, the passivation layer **70** at the B portion of the photoresist film over the data pad **64** is dry-etched while exposing the data pad **64**. The passivation layer and the underlying semiconductor layer **40** and gate insulating layer **30** at the B portion of the photoresist film over the gate pad **24** is dry-etched while partially leaving the gate insulating layer **30**. At this time, the gate insulating layer **30** over the gate pad **24** may be completely removed while exposing the underlying gate pad **24**. SF_6+N_2 or SF_6+HCL can be used for the dry etching, and the photoresist film PR at the display area D may be partially removed during the dry etching. Therefore, the consumption of the photoresist film PR should be controlled such that the passivation layer **70** at the display area D is not exposed to the outside. In this process, as shown in FIG. **14B**, the thickness of the photoresist film PR over the conductive pattern **68** becomes reduced by as much as that of the photoresist film PR at the display area D.

Thereafter, as shown in FIGS. **15A** and **15B**, the C portion of the photoresist film PR over the passivation layer **70** are removed through oxygen-based ashing. At this time, considering that the C portion of the photoresist film PR may be left with a non-uniform thickness, the ashing should be sufficiently performed by using N_6+O_2 or $Ar+O_2$. In this way, even though the C portion of the photoresist film is non-uniformly formed with a small thickness, it can be completely removed.

Thereafter, as shown in FIGS. **16A** and **16B**, the passivation layer **70** over the drain electrode **66**, the pixel area and the conductive pattern **68** as well as the gate insulating layer **30**

13

over the gate pad **24** are removed by using the photoresist pattern PR for a mask. In order to make etching conditions suitable for the semiconductor layer **40** and the passivation layer **70**, the etching gas preferably contains large amount of O_2 or CF_4 . SF_6+N_2 , SF_6+O_2 , CF_4+O_2 or $CF_4+CHF_3+O_2$ are preferably used for the dry etching.

As shown in FIGS. **17A** and **17B**, the semiconductor layer **40** between the neighboring data lines **62** is removed by etching, to complete the semiconductor patterns **42** and **48**. Cl_2+O_2 or $SF_6+HCl+O_2+Ar$ is preferably used for etching the semiconductor layer **40**.

Thereafter, as shown in FIGS. **4** and **5**, the upper layer **242** of the gate pad **24**, the upper layer **662** of the drain electrode **66**, the upper layer **642** of the data pad **64**, and the upper layer **682** of the conductive pattern **68** exposed to the outside are removed through dry-etching or wet-etching, and the remaining photoresist film PR is also removed. An ITO or IZO film is deposited onto the substrate **10**, and etched through a fourth mask. Consequently, a pixel electrode **82**, a supplemental gate pad **84** and a supplemental data pad **86** are formed while contacting the lower layer **661** of the drain electrode **66**, the lower layer **241** of the gate pad **24**, and the lower layer **641** of the data pad **64**, respectively.

As described above, in this preferred embodiment, the semiconductor patterns **42** and **48** together with the contact windows **71** to **73** is formed through one masking process and the desired TFT array substrate can be fabricated using only four masks. Furthermore, multiple etching can be uniformly performed on a large target area with different depth. In addition, the data or gate line assembly may have a double-layered structure with a low-resistance aluminum-based layer, eliminating poor contact characteristics of an aluminum-based layer at the pad portions.

In the meantime, when the upper layer **662** of the drain electrode **66**, and the upper layer **642** of the data pad **64** are etched, over-etching is liable to occur inside of the edge of the passivation layer **70**. In this case, the ITO or IZO film pattern for the pixel electrode **82** at the over-etched portion may be broken.

Second Preferred Embodiment

FIGS. **18** to **23** illustrate a method for fabricating a TFT array substrate according to a second preferred embodiment of the present invention. In this preferred embodiment, the processing steps are the same as those related to the first preferred embodiment up to the step of depositing the passivation layer **70** onto the substrate **10**.

As shown in FIG. **18**, a photoresist film PR is coated onto the passivation layer **70**. The photoresist film PR is exposed to light through a third mask, and developed to form a photoresist pattern. That is, the portion B of the photoresist film PR over the gate pad **24**, data pad **64** and drain electrode **66** is completely removed. The portion C of the photoresist film PR adjacent to the portion B over the drain electrode **66** and the data pad **64** and positioning at the pixel area is partially removed such that it has a small thickness. The remaining portion A of the photoresist film PR is left without being consumed.

Thereafter, as shown in FIG. **19**, the passivation layer **70**, the semiconductor layer **40** and the gate insulating layer **30** at the B portion of the photoresist film PR are dry-etched such that the gate pad **24**, the drain electrode **66** and the data pad **64** are exposed to the outside.

In this process, the A portion of the photoresist film PR may be partially removed.

14

Then, as shown in FIG. **20**, the upper layer **242** of the gate pad **24**, the upper layer **662** of the drain electrode **66** and the upper layer **642** of the data pad **64** are dry or wet-etched such that the lower layers **241**, **661** and **641** are exposed. The thin photoresist film PR over the drain electrode **66**, the pixel area and the data pad **64** are removed through oxygen-based ashing to expose the underlying passivation layer **70**.

As shown in FIG. **21**, the exposed passivation layer **70** over the drain electrode **66** and the data pad **64** is dry-etched such that the upper layer **662** of the drain electrode **66** and the upper layer **642** of the data pad **64** are exposed to the outside through the contact windows **71** and **73**. At this time, the passivation layer **70** at the pixel area and the underlying semiconductor layer **40** are also removed to complete semiconductor patterns **42** and **48**.

As shown in FIG. **22**, the remaining photoresist film PR is removed to complete the contact windows **71**, **72** and **73**.

As shown in FIG. **23**, an ITO or IZO film is deposited onto the entire surface of the substrate **10**, and etched through a fourth mask. As a result, a subsidiary gate pad **84**, a pixel electrode **82** and a subsidiary data pad **86** are formed while contacting the lower layer **241** of the gate pad **24**, the lower layer **661** of the drain electrode **66** and the lower layer **641** of the data pad **64**, respectively.

As described above, in this preferred embodiment, the semiconductor patterns **42** and **48** together with the contact windows **71** to **73** is formed through one masking process so that the desired TFT array substrate can be fabricated using only four mask. Furthermore, multiple etching can be uniformly performed on large target areas with different depth. In addition, the data or gate line assembly may have a double-layered structure with a low-resistance aluminum-based layer, not showing poor contact characteristics of an aluminum-based layer at the pad portions.

Furthermore, removing the passivation layer **70** after removing the upper layer **662** of the drain electrode **66** and the upper layer **642** of the data pad **64** eliminates the problem of over-etching the upper layers **662** and **642**. Therefore, the pixel electrode **82** and the subsidiary data pad **86** at the contact windows **71** and **73** can be prevented from breaking. In addition, the above structure can mitigate the height differences of the components at the contact windows **71** to **73**.

Third Preferred Embodiment

FIGS. **24** to **29** illustrate the steps of fabricating a TFT array substrate according to a third preferred embodiment of the present invention where a photosensitive organic layer is used for the passivation layer. In this preferred embodiment, the processing steps are similar to those related to the first preferred embodiment prior to the step of depositing a passivation layer onto the substrate **10**.

As shown in FIG. **24**, a photosensitive passivation layer **80** of a photosensitive organic material is deposited onto the substrate **10** to a thickness of 3,000 Å. The photosensitive passivation layer **80** is then exposed to light through a third mask, and developed to form a photoresist pattern. That is, the portion B of the photosensitive passivation layer **80** over the gate pad **24**, the data pad **64** and the drain electrode **66** is completely removed. The portion C of the photosensitive passivation layer **80** adjacent to the portion B over the drain electrode **66** and the data pad **64** and positioned at the pixel area is partially removed such that it has a small thickness. The remaining portion A of the photosensitive passivation layer **80** is left intact.

Thereafter, as shown in FIG. **25**, passivation the semiconductor layer **40** and the gate insulating layer **30** are dry-etched

15

through the removed portion B of the photosensitive passivation layer **80** exposing the gate pad **24**, the drain electrode **66** and the data pad **64**.

Then, as shown in FIG. **26**, the upper layer **242** of the gate pad **24**, the upper layer **662** of the drain electrode **66** and the upper layer **642** of the data pad **64** are dry or wet-etched exposing the lower layers **241**, **661** and **641**.

As shown in FIG. **27**, the thin photosensitive passivation layer **80** remaining over the drain electrode **66** and the data pad **64** is removed through oxygen-based etching to expose the upper layer **662** of the drain electrode **66** and the upper layer **642** of the data pad **64** to the outside through the contact windows **71** and **73**. At this time, the thin photosensitive passivation layer **80** remaining at the pixel area is also removed to expose the underlying semiconductor layer **40**.

As shown in FIG. **28**, the exposed semiconductor layer **40** is dry-etched to complete semiconductor patterns **42** and **48**.

As shown in FIG. **29**, an ITO or IZO film is deposited onto the entire surface of the substrate **10**, and etched through a fourth mask. As a result, a supplemental gate pad **84**, a pixel electrode **82** and a subsidiary data pad **86** are completed while contacting the lower layer **241** of the gate pad **24**, the lower layer **661** of the drain electrode **66** and the lower layer **641** of the data pad **64**, respectively.

This preferred embodiment, in addition to the advantages related to the previous preferred embodiments, simplifies the processing steps because the separate steps of processing a photoresist film after the formation of the passivation layer are not necessary.

Fourth Preferred Embodiment

FIGS. **30A** to **37B** illustrate the steps of fabricating a TFT array substrate according to a fourth preferred embodiment of the present invention. In this preferred embodiment, other components and structures of the TFT array substrate are similar to those related to the first preferred embodiment except that a single layered structure is used for the gate and data line assemblies, the conductive pattern **68** for the storage capacitor is eliminated, and an opening portion **31** is formed between the pixel electrode **82** and the data line **62** while exposing the substrate **10**. The gate and data line assemblies having a single layered structure of a metallic or conductive material such as Al, Al alloy, Mo, Mo—W alloy, Cr, and Ta are formed to a thickness of 1,000-4,000 Å. The opening portion **31** is to prevent a short circuit between the pixel electrode **82** and the data line **62** occurring when the semiconductor pattern **42** is over-extended toward the periphery of the data line **62**, and connected to the data line **62**.

In the method of fabricating the TFT array substrate according to the fourth preferred embodiment, the processing steps are similar as those related to the first preferred embodiment up to the step of depositing the passivation layer onto the substrate except that the gate and data line assemblies are formed with a single layered structure.

As shown in FIG. **30B**, a photoresist film PR is coated onto the passivation layer **70**. The photoresist film PR is exposed to light through a third mask. The light exposure to the photoresist film PR at the display area D is mainly different from that at the peripheral area P. That is, the exposed portions C and E of the photoresist film PR at the display area D over the drain electrode **66** and the pixel area react to light such that the molecules thereof are partially resolved to a predetermined depth from the surface while leaving the molecules thereunder intact. In contrast, the exposed portion B of the photoresist film PR at the peripheral area P over the gate pad **24** and the

16

data pad **64** reacts to the light such that the molecules thereof are completely resolved to the bottom.

The exposed portion B of the photoresist film PR at the display area D between the pixel area and the data line **62** also reacts to the light such that the molecules thereof are completely resolved to the bottom.

In order to achieve such different light exposures, the light transmission of the third mask at the display area D and the peripheral area P should be controlled appropriately.

As shown in FIG. **31**, the third mask for the above etching is formed with a transparent substrate **610**. The transparent substrate **610** is sequentially overlaid with a light transmission control film **620** and an opaque film **630**. It is preferable that the opaque film **630** has a light transmissivity of 3%, the light transmission control film **620** has a light transmissivity of 20-40%, and the transparent substrate **610** has a light transmissivity of 90% or more. The light transmission control film **620** and the opaque film **630** may be formed with materials having different light transmissivities, or with the same material while bearing a thickness different from each other. For instance, in the latter case, a chrome-based film having a thickness of 100-300 Å may be used for the light transmission control film **620**, and a chrome-based film sufficiently thicker than the light transmission control film **620** for the opaque film **630**.

According to the of light transmissivity, the mask can be divided into A, B, C and E portions corresponding to those portions of the photoresist film PR, and an additional F portion. The A portion has a lowest light transmissivity, and the B portion has a highest light transmissivity. The C portion has a light transmissivity between A and B. The E portion has a light transmissivity between B and C. The F portion has a light transmissivity between A and C. The substrate **610**, the light transmission control film **620** and the opaque film **630** are all present at the A portion. Only the substrate **610** is present at the B portion. The substrate **610** and the light transmission control film **620** are present at the C portion. The substrate **610** and the light transmission control film **620** are present at the E portion, but the light transmission control film **620** at the E portion has a plurality of slit patterns. The substrate **610**, the light transmission control film **620** and the opaque film **630** are all present at the F portion, but the opaque film **630** at the F portion has a plurality of slit patterns.

The slit patterns formed at the light transmission control film **620** and the opaque film **630** for the E and F portions have a width narrower than the resolution capability of the light source for the exposure such that the incident light diffracts and partially passes through the slit. Any patterns capable of inducing diffraction of the light may replace the slit patterns. For instance, mosaic patterns may be used for such purpose.

The reason for forming the slit or mosaic patterns at the required portions is to reduce the amount of light applied thereto. That is, when any metal component is present under the photoresist film to be exposed to light, the portion of the photoresist film under the metal component is applied with an increased amount of light due to the light reflected against the metal component so that the relevant portion of the photoresist film has a relatively small thickness compared to other portions. Furthermore, when the photoresist film is coated onto the protruded portion with the metal component, it is planarized to be placed on a plane with the photoresist film at other portions without the metal component so that the portion of the photoresist film over the metal component has a relatively small thickness compared to other portions. For these reasons, slit or mosaic patterns are formed at the mask portions corresponding to those of the photoresist film with

the underlying metal layers to reduce the amount of light applied thereto. Alternatively, a colored photoresist film may be used for that purpose.

As shown in FIGS. 32A and 32B, when the photoresist film PR exposed through the third mask is developed, a photoresist pattern PR is formed. That is, the B portion of the photoresist film over the gate and data pads 24 and 64 is completely removed, whereas the C portion of the photoresist film over the drain electrode 66 and the pixel area is partially removed leaving a relatively small thickness. The B portion of the photoresist film between the pixel area and the data line 62 is completely removed. The remaining A portion of the photoresist film is left with a relatively large thickness.

Thereafter, as shown in FIGS. 33A and 33B, the passivation layer 70 at the B portion over the data pad 64 is dry-etched while exposing the data pad 64, and the passivation layer 70 and the underlying semiconductor layer 40 and gate insulating layer 30 at the B portion over the gate pad 24 are dry-etched while partially leaving the gate insulating layer 30. At this time, the gate insulating layer 30 over the gate pad 24 may be completely removed while exposing the underlying gate pad 24. The passivation layer 70 and the gate insulating layer 30 at the B portion between the pixel area and the data line 62 are removed while partially leaving the gate insulating layer 30.

Thereafter, as shown in FIGS. 34A and 34B, the C portion of the photoresist film PR over the passivation layer 70 are removed through oxygen-based ashing.

Then, as shown in FIGS. 35A and 35B, the passivation layer 70 over the drain electrode 66 and the pixel area, and the gate insulating layer 30 remaining over the gate pad 24 is removed by using the photoresist pattern PR for a mask. At this time, the gate insulating layer 30 remaining between the pixel area and the data line 62 is also removed.

As shown in FIGS. 36A and 36B, the semiconductor layer 40 at the pixel area between the neighboring data lines 62 is removed by etching, thereby completing the semiconductor patterns 42.

Thereafter, as shown in FIGS. 37A to 37B, the remaining photoresist film PR is removed. An ITO or IZO film is deposited onto the substrate 10, and etched through a fourth mask. Consequently, a pixel electrode 82, a supplemental gate pad 84 and a supplemental data pad 86 are formed while contacting the drain electrode 66, the gate pad 24, and the data pad 64, respectively. Furthermore, the section 31 is opened between the pixel electrode 82 and the data line 62 to electrically separate them.

As is in the third preferred embodiment, the passivation layer 70 may be replaced by a photosensitive organic layer. In this case, the separate steps of processing a photoresist film may be eliminated.

This preferred embodiment, in addition to the advantages related to the previous preferred embodiments, can minutely divide the light transmissivity of the third mask while simplifying the relevant processing steps. Furthermore, the possible short circuit between the pixel electrode 82 and the data line 62 can be prevented by forming the opening portion 31.

Fifth Preferred Embodiment

FIGS. 38A to 40 illustrate the steps of fabricating a TFT array substrate according to a fifth preferred embodiment of the present invention. In this preferred embodiment, other components and structures of the array substrate are similar to those related to the first preferred embodiment except that a single layered structure is used for the gate and data line

assemblies, the conductive pattern 68 for the storage capacitor is eliminated, and a black matrix 90 and a color filter 100 are newly introduced.

In the method of fabricating the TFT array substrate according to the fifth preferred embodiment, the processing steps are similar to those related to the first preferred embodiment prior to the step of depositing the ITO or IZO film to form the pixel electrode 82.

As shown in FIG. 38B, after the semiconductor layer 40 is etched to form a semiconductor pattern and the remaining photoresist film PR is removed, an organic black matrix layer is deposited onto the substrate 10, and etched through a fourth mask to form a black matrix pattern 90. Alternatively, a black photoresist film may be used to form such a black matrix pattern.

Then, as shown in FIG. 39, a color filter 100 of red, green and blue is formed at the pixel area between the neighboring data lines 62. The color filter 100 formed through screen printing, or photolithography using fifth to seventh masks.

Finally, as shown in FIG. 40, an ITO film having a thickness of 400-500 Å is deposited onto the substrate 10, and etched through a fifth or eighth mask. Consequently, a pixel electrode 82, a supplemental gate pad 84, and a supplemental data pad 86 are completed.

In the resulting TFT array substrate, the black matrix 90 formed at the display area is to prevent light leakage due to the electric field present at the periphery of the pixel electrode 82. The portion of the black matrix 90 over the gate line 22 may be removed. The black matrix 90 has a narrow contact window for exposing the drain electrode 66 that is positioned at the center of the contact window 71 passing through the passivation layer 70.

The color filter 100 formed on the gate insulating layer 30 between the neighboring data lines 62 is alternated with the colors of red, green and blue. Such a color filter may be formed per one pixel area or per one longitudinal area defined by the neighboring data lines 62. The color filter 100 may be extended over the contact window 71. In this case, the color filter 100 should also have a separate contact window for interconnecting the drain electrode 66 and the pixel electrode 82. Such a contact window for the color filter 100 should have a size of at least $4\ \mu\text{m} \times 4\ \mu\text{m}$ because the color filter 100 is usually formed by using a large size aligner-based light exposure.

The above-mentioned structure can simplify the steps of fabricating the TFT array substrate. Furthermore, the black matrix 90 and the color filter 100 formed on the TFT array substrate, the marginal error when combining the TFT array substrate and the color filter substrate need not be considered, and can improve the opening ratio of the device.

Sixth Preferred Embodiment

FIGS. 41A and 41B illustrate the structure of a TFT array substrate according to a sixth preferred embodiment of the present invention. In this preferred embodiment, other components and structures of the TFT array substrate are similar to those related to the fifth preferred embodiment except that the black matrix 90 is absent. That is, among the processing steps for fabricating the TFT array substrate, the step of forming a black matrix pattern 90 is eliminated.

In the above structure, the opening ratio of the device is reduced compared to that related to the fifth preferred embodiment, but the black matrix to be formed with a common electrode at the opposite substrate can reduce the resistance of the common electrode.

Seventh Preferred Embodiment

FIGS. 42A to 45 illustrate the steps of fabricating a TFT array substrate according to a seventh preferred embodiment

of the present invention. In this preferred embodiment, other components and structures of the TFT array substrate are the similar to those related to the sixth preferred embodiment except that the passivation layer **70** has a new structure. For such a purpose, the passivation layer **70** is formed after the formation of the semiconductor pattern.

As shown in FIG. **42B**, a gate line assembly **22**, **24** and **26** is first formed at the substrate **10** by using a first mask. A gate insulating layer, a semiconductor layer, an ohmic contact layer, and a metal data line layer are then sequentially deposited onto the substrate **10**. The metal data line layer, the ohmic contact layer and the semiconductor layer are etched through a second mask to form the desired patterns. The semiconductor pattern **40**, the ohmic contact pattern **50**, and the data line assemblies **62** to **66** have similar shapes except that the semiconductor pattern **40** is present at the channel region between the source and drain electrodes **65** and **66**.

A single mask **2011** is used for the second mask. The mask **200** has a transparent substrate **210** overlaid with a light transmission control film **220** and an opaque film **230**. As shown in FIG. **43**, the portion of the mask corresponding to the data line assemblies **62** to **66** is provided with the light transmission control film **220** and the opaque film **230**, and the light transmissivity thereof is set to be 3% or less. The portion of the mask corresponding to the semiconductor pattern **40** between the source and drain electrodes **65** and **66** is provided with the light transmission control film **220**, and the light transmissivity thereof is established to be 20 to 40%. The remaining portion of the mask is provided only with the transparent substrate **210**, and the light transmissivity thereof is established to be 90% or more.

In the above etching process using the second mask, a photoresist film PR is first coated onto the substrate **10**, and exposed to light through the second mask. The photoresist film is then developed to thereby form a photoresist pattern.

Thereafter, the metal data line layer exposed through the photoresist pattern is etched while exposing the underlying ohmic contact layer. In this process, either a wet-etching technique or a dry-etching technique can be used, preferably under the condition that only the metal data line layer is etched while leaving the photoresist pattern. However, in the case of the dry etching, since it is difficult to make such a condition, the photoresist pattern may be allowed to be etched altogether.

When the metal data line layer is formed of Cr, wet etching is preferably used, with a solution of CeNH_3O_3 . When the metal data line layer is formed of Mo or MoW, dry etching is preferably used, with a mixture of CF_4 and HCl or CF_4 and O_2 .

As a result, the patterns **62** to **66** of the data line assembly are formed while exposing the underlying ohmic contact layer, except that the source and drain electrodes **65** and **66** are not yet separated from each other.

Thereafter, the exposed ohmic contact layer and the underlying semiconductor layer are removed through dry etching. Then, the photoresist film remaining over the channel portion of the metal data line layer between the source and drain electrode portions is removed.

The channel portion of the metal data line layer and the underlying ohmic contact layer are removed through etching. At this time, both the metal data line layer and the ohmic contact layer may be dry etched. Alternatively, dry etching the ohmic contact layer is dry etched and the metal data line layer is wet etched. In the former case, the etching is preferably performed under the condition that the etching selection ratio with respect to the metal layer and the contact layer is high. The reason is that when the etching selection ratio is low, it

becomes difficult to find the final etching point and the thickness of the semiconductor pattern to be left at the channel region cannot be controlled in an appropriate manner. In the latter case, the side portions of the metal layer being etched with the wet etching method are etched while leaving those portions of the contact layer being etched by the dry etching, rendering stepped portions. The mixture of CF_4 and O_2 is preferably used to form the semiconductor pattern **40** with a uniform thickness.

In this way, the source electrode **65** and the drain electrode **66** are separated from each other, completing the patterns **62** to **66** of the data line assembly and the underlying ohmic contact pattern **50**.

Thereafter, the photoresist film remaining over the data line assembly is removed.

As shown in FIG. **44**, a passivation layer **70** is deposited onto the substrate **10** with the data line assembly, and etched through a third mask to form contact windows **71** to **73**. An organic black matrix layer is then deposited onto the substrate **10**, and etched through a fourth mask to form a black matrix pattern **90**.

Finally, as shown in FIG. **45**, a color filter **100** as well as a pixel electrode **82**, a subsidiary gate pad **84** and a subsidiary data pad **86** are formed at the substrate **10** in the similar way as in the sixth preferred embodiment.

As is in the previous preferred embodiment, the above structure or technique can reduce the number of the processing steps, and enhance the opening ratio of the device.

Eighth Preferred Embodiment

FIGS. **46A** and **46B** illustrate the structure of a TFT array substrate according to an eighth preferred embodiment of the present invention. In this preferred embodiment, other components and structures of the TFT array substrate are the same as those related to the seventh preferred embodiment except that the passivation layer **70** is absent. The black matrix pattern **90** also serves the function of the passivation layer **70**. The black matrix pattern **90** is extended over the peripheral portion P. As the extension of the black matrix pattern **99** over the peripheral portion P may be realized also in the seventh preferred embodiment, only the step of processing the passivation layer **70** is skipped in this preferred embodiment. In this way, the number of processing steps can be reduced.

Ninth Preferred Embodiment

FIGS. **47A** and **47B** illustrate the structure of a TFT array substrate according to a ninth preferred embodiment of the present invention. In this preferred embodiment, other components and structures of the TFT array substrate are similar to those related to the fifth preferred embodiment except that the passivation layer **70** is absent, and the black matrix **90** serves the function of the passivation layer **70**. Therefore, the separate step of forming the passivation layer **70** is eliminated in this preferred embodiment.

The black matrix **90** is formed with a photosensitive material containing black pigments. In the etching process based on the third mask, the photosensitive matrix layer is itself exposed to light through the third mask without forming the photosensitive film PR, and developed to thereby form the black matrix pattern **90**. In the subsequent processing steps, the black matrix pattern **90** serves the function of the photoresist pattern PR.

In the above structure, the number of the processing steps can be reduced.

FIGS. 48A and 48B illustrate the structure of a TFT array substrate according to a tenth preferred embodiment of the present invention. In this preferred embodiment, other components and structures of the TFT array substrate are similar to those related to the ninth preferred embodiment except that the gate insulating layer 30 has a different pattern. That is, the portion of the gate insulating layer at the pixel area between the neighboring data lines is removed such that it has the same shape as that of the semiconductor pattern 40. Therefore, the color filter 100 is positioned directly over the substrate 10 and the gate line 22. The width of the removed portion of the gate insulating layer at the pixel area should be 1 μ or more. That is, the opening width of the semiconductor layer 40 should reach 1 μ or more. The opening prevents the currents from leaking between the neighboring data lines 62 via the semiconductor layer 40.

In the method of fabricating the TFT array substrate according to the tenth preferred embodiment, the processing steps are similar to those related to the ninth preferred embodiment except that a usual mask with only a transparent portion and an opaque portion is used for the third mask. That is, the transparent portion of the mask corresponds to the portion of the target film to be removed, while the opaque portion corresponds to the portion of the target film to remain.

When the photosensitive black matrix pattern 90 is formed by using the usual mask, and the underlying semiconductor layer and gate insulating layer are etched by using the photosensitive black matrix pattern 90 as a photoresist pattern PR, exposing the portions of the substrate 10 and the gate line 21 between the neighboring data lines 62 to the outside, and the contact windows 71 to 73 are also formed.

Thereafter, a color filter 100 as well as a pixel electrode 82, a supplemental gate pad 84 and a supplemental data pad 86 are formed in the similar way as in the ninth preferred embodiment. The color filter 100 completely covers the exposed portion of the gate line 22 to insulate the gate line 22 from the pixel electrode 82.

The above mentioned structure can reduce, the number of processing steps even with the usual mask having only transparent and opaque portions.

As described above, the TFT array substrate of the present invention can be fabricated with simplified processing steps while achieving good performance characteristics.

While the present invention has been described in detail with reference to the preferred embodiments, those skilled in the art will appreciate that various modifications and substitutions can be made thereto without departing from the spirit and scope of the present invention as set forth in the appended claims.

What is claimed is:

[1. A thin film transistor array substrate for a liquid crystal display, comprising:

an insulating substrate;

a gate line assembly formed on the substrate, the gate line assembly having a plurality of gate lines proceeding in the horizontal direction, gate electrodes branched from the gate lines, and gate pads connected to end portions of the gate lines;

a gate insulating layer formed on the gate line assembly, the gate insulating layer having a first contact window exposing the gate pad, and an opening portion partially exposing the insulating substrate;

a semiconductor pattern formed on the gate insulating layer;

a contact pattern formed on the semiconductor pattern;

a data line assembly formed on the contact pattern with substantially the same outline as the contact pattern, the data line assembly having data lines proceeding in the vertical direction, source electrodes branched from the data lines, data pads connected to end portions of the data lines, and drain electrodes positioned opposite to the source electrodes with respect to the gate electrode while being separated from the source electrodes;

a passivation layer formed on the data line assembly with the same outline as the semiconductor pattern except at portions of a second contact window exposing the data pad and a third contact window exposing the drain electrode;

a pixel electrode formed at a pixel area defined by the neighboring gate and data lines, the pixel electrode being electrically connected to the drain electrode through the third contact window while partially contacting the gate insulating layer; and

subsidiary gate and data pads contacting the gate and data pads, respectively.]

[2. The thin film transistor array substrate of claim 1 wherein the opening portion exposes the substrate between the pixel electrode and the neighboring data line.]

[3. The thin film transistor array substrate of claim 1 wherein the third contact window exposing the drain electrode is extended such that the borderline of the drain electrode is exposed to the outside.]

[4. A thin film transistor array substrate for a liquid crystal display comprising:

an insulating substrate;

a gate line assembly formed on the substrate, the gate line assembly having a plurality of gate lines proceeding in the horizontal direction, gate electrodes branched from the gate lines, and gate pads connected to end portions of the gate lines;

a first insulating layer formed on the gate line assembly, the first insulating layer having a first contact window exposing the gate pad;

a semiconductor pattern longitudinally formed on the first insulating layer in the vertical direction;

a data line assembly formed on the semiconductor pattern, the data line assembly having data lines proceeding in the vertical direction, source electrodes branched from the data lines, data pads connected to end portions of the data lines, and drain electrodes positioned opposite to the source electrodes with respect to the gate electrodes while being separated from the source electrodes;

a second insulating layer formed on the data line assembly with the same outline as the semiconductor pattern, the second insulating layer having a second contact window exposing the gate pad through the first contact window, a third contact window exposing the data pad, and a fourth contact window exposing the drain electrode;

a color filter formed at a pixel area defined by the neighboring gate and data lines; and

a pixel electrode formed on the color filter, the pixel electrode being connected to the drain electrode through the fourth contact window.]

[5. The thin film transistor array substrate of claim 4 further comprising a contact layer formed between the semiconductor pattern and the data line assembly with the same outline as the data line assembly.]

[6. The thin film transistor array substrate of claim 4 further comprising supplemental gate pads and supplemental data pads covering the gate pad and the data pad, respectively.]

[7. The thin film transistor array substrate of claim 4 further comprising a photo-interceptive organic pattern formed between the data line assembly and the overlying passivation layer.]

[8. The thin film transistor array substrate of claim 7 wherein the photo-interceptive pattern is provided with a fifth contact window exposing the drain electrode through the fourth contact window, the fifth contact window being narrower than the fourth contact window.]

[9. The thin film transistor array substrate of claim 4 wherein the second insulating layer is formed of a photo-interceptive organic layer.]

[10. The thin film transistor array substrate of claim 9 wherein the first insulating layer has the same outline as the semiconductor pattern.]

[11. The thin film transistor array substrate of claim 10 wherein the opening width of the semiconductor pattern between the neighboring data lines is 1 μ or more.]

[12. A thin film transistor array substrate for a liquid crystal display, comprising:

an insulating substrate;

a gate line assembly formed on the substrate, the gate line assembly having a plurality of gate lines proceeding in the horizontal direction, gate electrodes branched from the gate lines, and gate pads connected to end portions of the gate lines;

a first insulating layer formed on the gate line assembly, the first insulating layer having a first contact window exposing the gate pad;

a semiconductor pattern longitudinally formed on the first insulating layer in the vertical direction;

a data line assembly formed on the semiconductor pattern, the data line assembly having data lines proceeding in the vertical direction, source electrodes branched from the data lines, data pads connected to end portions of the data lines, and drain electrodes positioned opposite to the source electrodes with respect to the gate electrodes while being separated from the source electrodes, the data line assembly substantially having the same outline as the semiconductor pattern except the portion placed between the source electrode and the drain electrode;

a second insulating layer formed on the data line assembly, the second insulating layer having a second contact window exposing the first contact window, a third contact window exposing the data pad, and a fourth contact window exposing the drain electrode;

a color filter formed on the passivation layer at a pixel area defined by the neighboring gate and data lines; and

a pixel electrode formed on the color filter, the pixel electrode being connected to the drain electrode through the fourth contact window.]

[13. The thin film transistor array substrate of claim 12 further comprising a contact layer formed between the semiconductor pattern and the data line assembly substantially with the same outline as the data line assembly.]

[14. The thin film transistor array substrate of claim 12 further comprising supplemental gate pads and supplemental data pads covering the gate pads and the data pads, respectively.]

[15. The thin film transistor array substrate of claim 12 further comprising a photo-interceptive organic pattern formed on the passivation layer over the data line assembly and the gate line assembly.]

[16. The thin film transistor array substrate of claim 15 wherein the photo-interceptive organic pattern is provided with a fifth contact window exposing the drain electrode through the fourth contact window, the fifth contact window being narrower than the fourth contact window.]

[17. The thin film transistor array substrate of claim 12 wherein the second insulating layer is formed with a photo-interceptive organic layer.]

18. *A thin film transistor array substrate for a liquid crystal display comprising:*

an insulating substrate;

a gate line assembly formed on the substrate, the gate line assembly having a plurality of gate lines proceeding in the horizontal direction, gate electrodes connected to the gate lines, and gate pads connected to end portions of the gate lines;

a first insulating layer formed on the gate line assembly, the first insulating layer having a first contact window exposing the gate pad, and an opening portion partially exposing the insulating substrate;

a semiconductor pattern formed on the first insulating layer;

a contact pattern formed on the semiconductor pattern;

a data line assembly formed on the contact pattern with substantially the same outline as the contact pattern, the data line assembly having data lines proceeding in the vertical direction, source electrodes connected to the data lines, data pads connected to end portions of the data lines, and drain electrodes positioned opposite to the source electrodes with respect to the gate electrode while being separated from the source electrodes;

a second insulating layer formed on the data line assembly with the same outline as the semiconductor pattern except at portions of a second contact window exposing the data pad and a third contact window exposing the drain electrode;

a pixel electrode formed at a pixel area defined by the neighboring gate and data lines, the pixel electrode being electrically connected to the drain electrode through the third contact window while partially contacting the first insulating layer; and subsidiary gate and data pads contacting the gate and data pads, respectively.

19. *The thin film transistor array substrate of claim 18, wherein the third contact window exposing the drain electrode is extended such that the borderline of the drain electrode is exposed to the outside.*

20. *The thin film transistor array substrate of claim 18, wherein the second insulating layer is the photo-interceptive layer.*

21. *The thin film transistor array substrate of claim 18, wherein the data line assembly has a double layered structure comprising a first metallic layer and a second metallic layer, and*

the first metallic layer is formed of at least one of a material such as Cr, Mo or Mo alloy, and the second metallic layer is formed of at least one of a material such as Al or Al alloy, and

the pixel electrode is electrically connected to the first metallic layer.