

US00RE42662E

(19) **United States**
(12) **Reissued Patent**
Guglielmi et al.

(10) **Patent Number:** **US RE42,662 E**
(45) **Date of Reissued Patent:** **Aug. 30, 2011**

(54) **ENDOVASCULAR ELECTROLYTICALLY DETACHABLE WIRE AND TIP FOR THE FORMATION OF THROMBUS IN ARTERIES, VEINS, ANEURYSMS, VASCULAR MALFORMATIONS AND ARTERIOVENOUS FISTULAS**

(75) Inventors: **Guido Guglielmi**, Rome (IT); **Ivan Sepetka**, Los Altos, CA (US)

(73) Assignee: **The Regents of the University of California**, Oakland, CA (US)

(*) Notice: This patent is subject to a terminal disclaimer.

(21) Appl. No.: **11/377,892**

(22) Filed: **Mar. 15, 2006**

Related U.S. Patent Documents

Reissue of:

(64) Patent No.: **6,083,220**
Issued: **Jul. 4, 2000**
Appl. No.: **08/647,114**
Filed: **May 9, 1996**

U.S. Applications:

(60) Division of application No. 08/485,821, filed on Jun. 6, 1995, now abandoned, which is a division of application No. 08/311,508, filed on Sep. 23, 1994, now Pat. No. 5,540,680, which is a continuation of application No. 07/840,211, filed on Feb. 24, 1992, now Pat. No. 5,354,295, which is a continuation-in-part of application No. 07/492,717, filed on Mar. 13, 1990, now Pat. No. 5,122,136.

(51) **Int. Cl.**
A61B 18/08 (2006.01)
A61B 17/00 (2006.01)

(52) **U.S. Cl.** **606/32; 606/41; 606/108; 606/191**

(58) **Field of Classification Search** **606/32, 606/41, 108, 191, 49, 28, 200; 623/1.1; 604/104; 600/585; 607/122**

See application file for complete search history.

(56) **References Cited**

U.S. PATENT DOCUMENTS

2,839,049 A 6/1958 MacLean 128/756
(Continued)

FOREIGN PATENT DOCUMENTS

AT 0197237 E 3/2001
(Continued)

OTHER PUBLICATIONS

Castañeda-Zuniga, WR; M Epstein, et al. "Embolization of Multiple Pulmonary Artery Fistulas," *Radiology* 134:309-10, Feb. 1980.

(Continued)

Primary Examiner — Lee S Cohen

(74) *Attorney, Agent, or Firm* — Fenwick & West LLP

(57) **ABSTRACT**

An artery, vein, aneurysm, vascular malformation or arterial fistula is occluded through endovascular occlusion by the endovascular insertion of a platinum wire and/or tip into the vascular cavity. The vascular cavity is packed with the tip to obstruct blood flow or access of blood in the cavity such that the blood clots in the cavity and an occlusion is formed. The tip may be elongate and flexible so that it packs the cavity by being folded upon itself a multiple number of times, or may pack the cavity by virtue of a filamentary or fuzzy structure of the tip. The tip is then separated from the wire mechanically or by electrolytic separation of the tip from the wire. The wire and the microcatheter are thereafter removed leaving the tip embedded in the thrombus formed within the vascular cavity. Movement of wire in the microcatheter is more easily tracked by providing a radioopaque proximal marker on the microcatheter and a corresponding indicator marker on the wire. Electrothrombosis is facilitated by placing the ground electrode on the distal end of the microcatheter and flowing current between the microcatheter electrode and the tip.

10 Claims, 6 Drawing Sheets

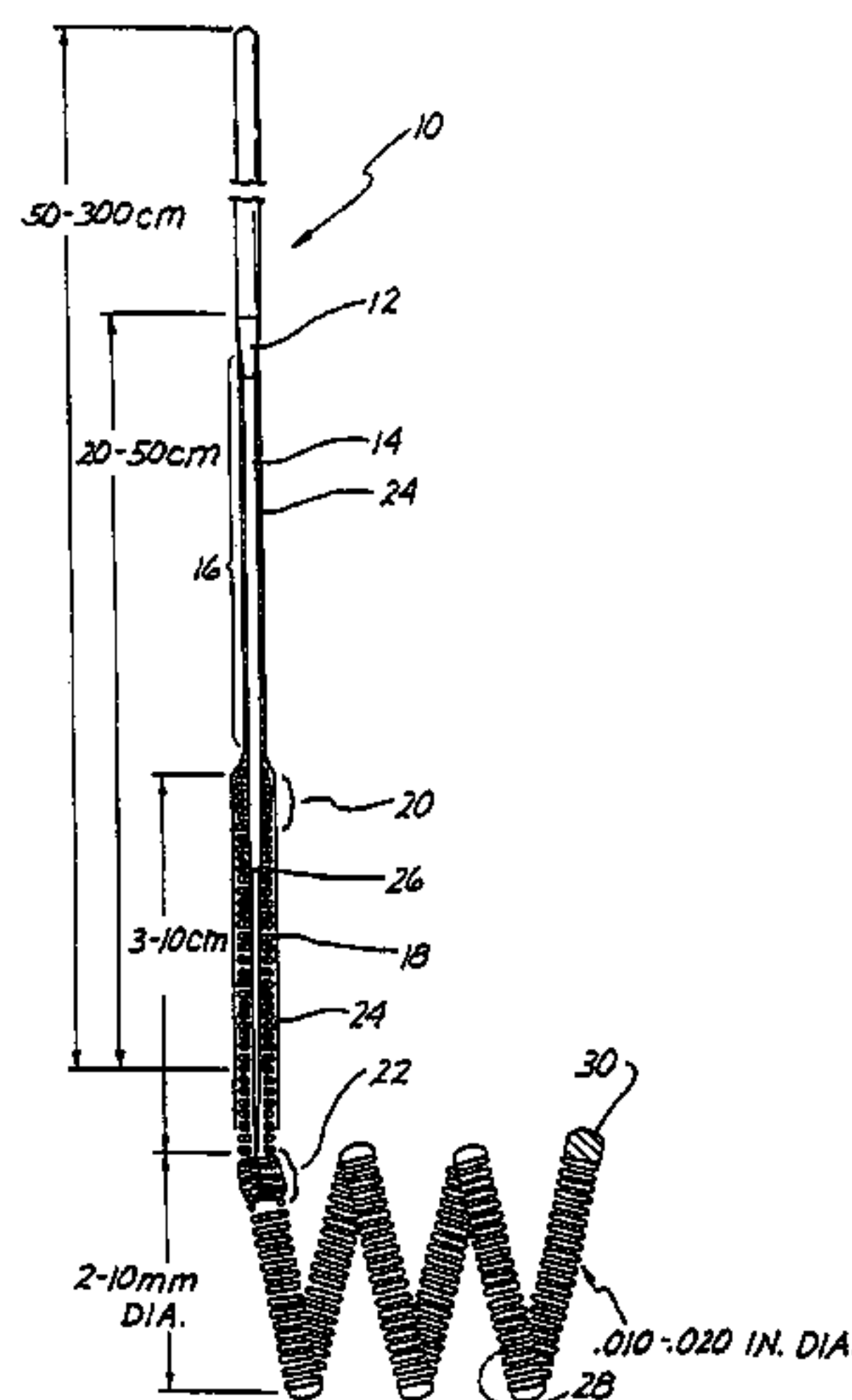

US RE42,662 E

Page 2

U.S. PATENT DOCUMENTS						
3,334,629	A	8/1967	Cohn	5,104,376 A	4/1992	Crittenden
3,452,742	A	7/1969	Muller	5,108,407 A	4/1992	Geremia et al.
3,521,620	A	7/1970	Cook	5,108,416 A	4/1992	Ryan et al.
3,547,103	A	12/1970	Cook	RE33,925 E	5/1992	Bales et al.
3,605,750	A	9/1971	Sheridan et al.	5,109,867 A	5/1992	Twyford, Jr.
3,773,034	A	11/1973	Burns et al.	5,116,652 A	5/1992	Alzner
3,789,841	A	2/1974	Antoshkiw	5,122,136 A	6/1992	Guglielmi et al.
3,868,956	A	3/1975	Alfidi et al.	5,133,731 A	7/1992	Butler et al.
3,952,747	A	4/1976	Kimmell, Jr.	5,135,516 A	8/1992	Sahatjian et al.
3,996,938	A	12/1976	Clark, III	5,143,085 A	9/1992	Wilson
4,003,369	A	1/1977	Heilman et al.	5,154,179 A	10/1992	Ratner
4,080,706	A	3/1978	Heilman et al.	5,167,624 A	12/1992	Butler et al.
4,114,603	A	9/1978	Wilkinson	5,169,386 A	12/1992	Becker et al.
4,147,169	A	4/1979	Taylor	5,171,233 A	12/1992	Amplatz et al.
4,190,057	A	2/1980	Hill et al.	5,171,297 A	12/1992	Barlow et al.
4,213,461	A	7/1980	Pevsner	5,178,618 A	1/1993	Kandarpa
4,323,071	A	4/1982	Simpson et al.	5,180,368 A	1/1993	Garrison
4,327,734	A	5/1982	White, Jr.	5,188,621 A	2/1993	Samson
4,341,218	A	7/1982	U	5,191,297 A	3/1993	Penman et al.
4,346,712	A	8/1982	Handa et al.	5,201,323 A	4/1993	Vermeulen
4,402,319	A	9/1983	Handa et al.	5,201,754 A	4/1993	Crittenden et al.
4,411,648	A	10/1983	Davis et al.	5,209,730 A	5/1993	Sullivan
4,613,324	A	10/1983	Morrison	5,217,484 A	6/1993	Marks
4,413,989	A	11/1983	Schjeldahl et al.	5,226,911 A	7/1993	Chee et al.
4,512,338	A	4/1985	Balko et al.	5,234,437 A	8/1993	Sepetka
4,517,979	A	5/1985	Pecenka	5,242,396 A	9/1993	Evard
4,522,205	A	6/1985	Taylor et al.	5,246,421 A	9/1993	Saab
4,538,622	A	9/1985	Samson et al.	5,250,071 A	10/1993	Palermo
4,545,367	A	10/1985	Tucci	5,254,130 A	10/1993	Poncet et al.
4,545,390	A	10/1985	Leary	5,261,916 A	11/1993	Engelson
4,554,929	A	11/1985	Samson et al.	5,263,964 A	11/1993	Purdy
4,576,174	A	3/1986	Miyazaki et al.	5,264,421 A	11/1993	Satoh et al.
4,597,389	A	7/1986	Ibrahim et al.	5,275,594 A	1/1994	Baker et al.
4,619,274	A	10/1986	Morrison	5,304,195 A	4/1994	Twyford, Jr. et al.
RE32,348	E	2/1987	Pevsner	5,306,287 A	4/1994	Becker
4,641,654	A	2/1987	Samson et al.	5,312,415 A	5/1994	Palermo
4,655,746	A	4/1987	Daniels et al.	5,334,210 A	8/1994	Gianturco
4,660,571	A	4/1987	Hess et al.	5,342,294 A	8/1994	Wiest et al.
4,669,465	A	6/1987	Moore et al.	5,342,387 A	8/1994	Summers
4,682,596	A	7/1987	Bales et al.	5,345,927 A	9/1994	Bonutti
4,723,556	A	2/1988	Sussman	5,350,397 A	9/1994	Palermo et al.
4,729,914	A	3/1988	Kliment et al.	5,354,295 A	10/1994	Guglielmi et al.
4,735,201	A	4/1988	O'Reilly	5,360,443 A	11/1994	Barone et al.
4,739,768	A	4/1988	Engelson	5,382,261 A	1/1995	Palmaz
4,748,986	A	6/1988	Morrison et al.	5,423,829 A	6/1995	Pham et al.
4,782,834	A	11/1988	Maguire et al.	5,449,372 A	9/1995	Schmaltz et al.
4,787,899	A	11/1988	Lazarus	5,454,826 A	10/1995	Ueda
4,793,359	A	12/1988	Sharrow	5,522,836 A	6/1996	Palermo
4,800,882	A	1/1989	Gianturco	5,540,680 A	7/1996	Guglielmi et al.
4,813,934	A	3/1989	Engelson et al.	5,569,245 A	10/1996	Guglielmi et al.
4,820,298	A	4/1989	Leveen et al.	5,609,608 A	3/1997	Benett et al.
4,821,722	A	4/1989	Miller et al.	5,645,558 A	7/1997	Horton
4,830,003	A	5/1989	Wolff et al.	5,645,564 A	7/1997	Northrup et al.
4,832,047	A	5/1989	Sepetka et al.	5,690,666 A	11/1997	Berenstein et al.
4,838,268	A	6/1989	Keith et al.	5,718,711 A	2/1998	Berenstein et al.
4,838,879	A	6/1989	Tanabe et al.	5,724,534 A	3/1998	Boursier et al.
4,878,906	A	11/1989	Lindemann et al.	5,725,552 A	3/1998	Kotula et al.
4,884,579	A	12/1989	Engelson	5,733,294 A	3/1998	Forber et al.
4,907,336	A	3/1990	Gianturco	5,743,905 A	4/1998	Eder et al.
4,917,088	A	4/1990	Crittenden	5,766,219 A	6/1998	Horton
4,943,278	A	7/1990	Euteneuer et al.	5,797,953 A	8/1998	Tekulve
4,944,746	A	7/1990	Iwata et al.	5,800,454 A	9/1998	Jacobsen et al.
4,950,239	A	8/1990	Gahara et al.	5,814,062 A	9/1998	Sepetka et al.
4,968,306	A	11/1990	Huss et al.	5,826,587 A	10/1998	Berenstein et al.
4,969,458	A	11/1990	Wiktor	5,851,206 A	12/1998	Guglielmi et al.
4,986,830	A	1/1991	Owens et al.	5,855,578 A	1/1999	Guglielmi et al.
4,989,608	A	2/1991	Ratner	5,882,334 A	3/1999	Sepetka et al.
4,991,069	A	2/1991	Tiller	5,891,128 A	4/1999	Gia et al.
4,994,069	A	2/1991	Ritchart et al.	5,891,130 A	4/1999	Palermo et al.
4,998,933	A	3/1991	Eggers et al.	5,891,155 A	4/1999	Irie
5,002,556	A	3/1991	Ishida et al.	5,895,385 A	4/1999	Guglielmi et al.
5,011,482	A	4/1991	Goode et al.	5,895,391 A	4/1999	Farnholtz
5,019,075	A	5/1991	Spears et al.	5,911,717 A	6/1999	Jacobsen et al.
5,021,043	A	6/1991	Becker et al.	5,916,235 A	6/1999	Guglielmi
5,041,090	A	8/1991	Scheglov et al.	5,919,187 A	7/1999	Guglielmi et al.
5,055,101	A	10/1991	McCoy	5,925,037 A	7/1999	Guglielmi et al.
5,061,914	A	10/1991	Busch et al.	5,925,062 A	7/1999	Purdy
5,102,390	A	4/1992	Crittenden et al.	5,928,226 A	7/1999	Guglielmi et al.
				5,944,714 A	8/1999	Guglielmi et al.

US RE42,662 E

Page 3

5,944,733	A	8/1999	Engelson	EP	0220285	B1	7/1992
5,947,962	A	9/1999	Guglielmi et al.	EP	0493878	A2	7/1992
5,947,963	A	9/1999	Guglielmi	EP	0493878	A3	7/1992
5,972,019	A	10/1999	Engelson et al.	EP	0494495	A1	7/1992
5,976,126	A	11/1999	Guglielmi	EP	0495861	B1	5/1993
5,976,131	A	11/1999	Guglielmi et al.	EP	0484468	A4	3/1994
5,980,514	A	11/1999	Kupiecki et al.	EP	0375775	B1	8/1994
6,010,498	A	1/2000	Guglielmi	EP	0629125	A1	5/1995
6,063,220	A	5/2000	Andersson	EP	0484486	B1	1/1996
6,066,133	A	5/2000	Guglielmi et al.	EP	0707830	A1	4/1996
6,083,220	A	7/2000	Guglielmi et al.	EP	0750886	A1	1/1997
6,096,034	A	8/2000	Kupiecki et al.	EP	0 804 906	A3	5/1997
6,168,592	B1	1/2001	Kupiecki et al.	EP	0 800 790	A2	10/1997
6,168,615	B1	1/2001	Ken et al.	EP	0 800 790	A3	10/1997
6,238,415	B1	5/2001	Sepetka et al.	EP	0 803 230	A2	10/1997
6,344,041	B1	2/2002	Kupiecki et al.	EP	0 803 230	A3	11/1997
6,425,893	B1	7/2002	Guglielmi	EP	0 804 904	A1	11/1997
6,468,266	B1	10/2002	Bashiri et al.	EP	0 804 905	A1	11/1997
6,620,152	B2	9/2003	Guglielmi	EP	0 629 125	B1	6/1998
2002/0151883	A1	10/2002	Guglielmi	EP	0 804 906	B1	1/1999

FOREIGN PATENT DOCUMENTS

AU	58652/86	11/1986	EP	0914803	A1	5/1999
AU	591906	11/1986	EP	0 484 468	B1	6/1999
AU	39345/89 A	11/1989	EP	0 800 790	B1	7/1999
AU	621923	11/1989	EP	0 804 905	B1	7/1999
AU	74474/91	10/1991	EP	1 005 837	A2	6/2000
AU	0636217 B2	10/1991	EP	1 005 837	A3	6/2000
AU	0673502 B2	9/1993	EP	0 803 230	B1	11/2000
AU	34291/95	5/1996	EP	0 707 830	B1	2/2001
AU	704583	5/1996	EP	1 005 837	B1	4/2003
AU	56244/96	1/1997	EP	0750886	B1	4/2003
AU	0723902 B2	1/1997	EP	0 914 803	B1	7/2003
CA	1308988	10/1992	EP	1 323 385	A2	7/2003
CA	2160640	4/1996	EP	1 323 385	A3	7/2003
CA	2179863	12/1996	EP	1 329 196	A1	7/2003
CA	2055492 C	11/2000	FI	9615332		11/1991
DD	158.084	12/1982	FI	941937		6/1994
DD	223 065 A1	6/1985	GB	2185190	A	7/1987
DE	3 203 410	11/1982	GB	2208607	A	4/1989
DE	3334174 A1	3/1984	GB	2245495	A	1/1992
DE	3334174 C2	3/1984	HU	219694	B	1/1991
DE	3690224 T1	8/1987	HU	0913536		1/1991
DE	69001759 T2	1/1994	IL	0115609		10/1995
DE	3690224 C2	11/1998	IL	115609		10/1995
DE	69226024 T2	1/1999	IT	1224838		10/1990
DE	69228134 T2	5/1999	JP	62-502950		11/1987
DE	69131340 T2	10/1999	JP	5-500322		1/1993
DE	69131466 T2	11/1999	JP	5-38366		2/1993
DE	69131467 T2	11/1999	JP	5-23153		3/1993
DE	69231550 T2	6/2001	JP	6-26576		4/1994
DE	69520186 T2	6/2001	JP	7-503165		4/1995
DE	69233026 T2	1/2004	JP	2501389		3/1996
DE	69627243 T2	1/2004	JP	8-196544		8/1996
DE	69133297 T2	6/2004	JP	9-98981		4/1997
DK	0803230	10/1997	JP	3131386		11/2000
EP	0 117 940 A2	9/1984	JP	3152399		1/2001
EP	0 119 688 A2	9/1984	KR	10-0200441		6/1999
EP	0058708 B1	5/1985	NO	914433		1/1992
EP	0220285	11/1986	NO	943106		8/1994
EP	0212936 A1	3/1987	NO	962745		1/1997
EP	0249371 A2	12/1987	PT	101162		12/1992
EP	0249371 A3	12/1987	WO	WO 82/00768		3/1982
EP	0253620 A2	1/1988	WO	WO 84/04686		12/1984
EP	0253620 A3	1/1988	WO	WO 86/06285		11/1986
EP	0255331 A2	2/1988	WO	WO 87/00062		1/1987
EP	0255331 A3	2/1988	WO	WO 88/01851		3/1988
EP	0296224	6/1988	WO	WO 90/01840		2/1990
EP	0296224	3/1989	WO	WO 90/02585		3/1990
EP	0220285	11/1989	WO	WO 91/13592		1/1991
EP	0471683	4/1990	WO	WO 91/04716		4/1991
EP	0366407 A2	5/1990	WO	WO 92/01425		2/1992
EP	0366407 A3	5/1990	WO	WO 92/08342		5/1992
EP	0471754	5/1990	WO	WO 92/14408		9/1992
EP	0 397 357 A1	11/1990	WO	WO 92/21400		12/1992
EP	0 422 632 A2	4/1991	WO	WO 93/11825		6/1993
EP	0442657 A2	8/1991	WO	WO 93/16650		9/1993
EP	0516717	9/1991	WO	WO 94/06503		3/1994
EP	0471683	1/1992	WO	WO 94/10936		5/1994
			WO	WO 95/23558		9/1995

WO	WO 95/25480	9/1995
WO	WO 97/48351	12/1997
WO	WO 98/02100	1/1998
WO	WO 98/04195	2/1998
WO	WO 98/04196	2/1998
WO	WO 98/04198	2/1998
WO	WO 98/04315	2/1998
WO	WO 01/32085 A1	5/2001
WO	WO 02/14408	2/2002
WO	WO 03/017852 A1	3/2003
ZA	81-2814	4/1981

OTHER PUBLICATIONS

Guglielmi Record of Invention Disclosure to UC, Jun. 15, 1989.

Guglielmi, G., Vinuela, Becker, D, et al: "Experimental endovascular occlusion of small and medium-sized saccular aneurysms by electrothrombosis. Potential uses in the clinical setting." In: Proceedings of the 58th Annual Meeting of the American Association of Neurological Surgeons, Nashville, Tennessee. Apr.-May 1990. (Presentation).

Hare, H. "Wiring With Electrolysis in Saccular Aneurysm," Jour. A.M.A (JAMA), 38:230-232, Jan. 22, 1927.

Hilal presentation at Stonwin Medical Conference, Scarsdale, NY, Jul. 10-12, 1989. "Treatment of Intracranial aneurysms and arteriovenous malformations with preshaped thrombogenic coils". Hilal SK.

Joseph, GJ. "Platinum Wire Microcoils for Transvascular Embolization with Microcatheter Systems," Radiology, 169(P):341, 1988.

Marsman, "Evaluation of a New Distal Delivery Guidewire for Steel Coils," Europ. J. Radiol., 2:250-253, 1982.

Target Therapeutic Dec. 3, 1991 letter to Food and Drug Administration with Submission of Supplemental IDE—G900241—Detachable Platinum Coil.

Berenstein, A., et al., "Transvascular Treatment of Giant Aneurysms of the Cavernous Carotid and Vertebral Arteries," Surg Neurol, 1984, pp. 3-12, vol. 21.

Canadian Patent Application No. 2,160,640 Patent Application Status, 1 page.

Canadian Patent Application No. 2,055,492, Patent Application File History, 93 pages.

Canadian Patent Application No. 2,179,863 Patent Application File History, 39 pages.

Castaneda-Zuniga, W. et al., "A New Device for the Safe Delivery of Stainless Steel Coils," Radiology, Jul. 1980, pp. 230-231, vol. 136.

Debrun, G. et al., "Experimental Approach to the Treatment of Carotid Cavernous Fistulas with an Inflatable and Isolated Balloon," Neuroradiology, 1975, pp. 9-12, vol. 9.

Fox, A.J. et al., "Use of Detachable Balloons for Proximal Artery Occlusion in the Treatment of Unclippable Cerebral Aneurysms," J Neurosurg, 1987, pp. 40-46, vol. 66.

Halbach, V.V. et al., "Transvenous Embolization of Direct Carotid Cavernous Fistulas," AJNR, Jul./Aug. 1988, pp. 741-747, vol. 9.

Kwan, E.S.K. et al., "Enlargement of Basilar Artery Aneurysms Following Balloon Occlusion—"Water Hammer Effect"" J Neurosurg, 1991, pp. 963-968, vol. 75.

Massoud, T.F. et al., "Laboratory Simulations and Training in Endovascular Embolotherapy with a Swine Arteriovenous Malformation Model," AJNR, Feb. 1996, pp. 271-279, vol. 17.

Mickle, J.P. et al., "The Transtorcular Embolization of Vein of Galen Aneurysms," J. Neurosurg., May 1986, vol. 64., pp. 731-735.

Purdy, P.D., "Imaging Cerebral Blood Flow in Interventional Neuroradiology: Choice of Technique and Indications," AJNR, May/ Jun. 1991, pp. 424-427, vol. 12.

Byrne, J.V. et al., "The Nature of Thrombosis Induced by Platinum and Tungsten Coils in Saccular Aneurysms," Am J. Neuroradiology, Jan. 1997, pp. 29-33, vol. 18.

"Excelsior 1018 Microcatheter," Boston Scientific Therapeutic, 2000, 4 pages.

"Guglielmi Detachable Coil (GDC®) Product Information Summary," 36 pages.

Guglielmi, G. et al., "Detachable Microcoils in the Endovascular Treatment of Intracranial Aneurysms: Preliminary Clinical Experience," Endovascular Therapy, Session VII/Paper 35, p. 73.

Guglielmi, G. et al., "Endovascular Treatment of Posterior Circulation Aneurysms by Electrothrombosis Using Electrically Detachable Coils," J. Neurosurg., Oct. 1992, pp. 515-524.

Horowitz, M. et al., "Does Electrothrombosis Occur Immediately After Embolization of an Aneurysm With Guglielmi Detachable Coils," AJNR, Mar. 1997, pp. 510-513, vol. 18.

Johnston, S.C. et al., "Recommendations for the Endovascular Treatment of Intracranial Aneurysms," Stroke, 2002, pp. 2536-2544, vol. 33.

Konishi Y. et al., "Evaluation of Acute Thrombogenesis of Microcoil for Treatment of Experimental Aneurysms," 1 page.

Linton, R. R. et al., "Treatment of Thoracic Aortic Aneurysms by The "Pack" Method of Intracatheter Wiring," The New England Journal of Medicine, Jan.-Jun. 1952, pp. 847-855, vol. 246.

Lylyk, P. et al., "Therapeutic Alternatives for Vein of Galen Vascular Malformations," J. Neurosurg., Mar. 1993, pp. 438-445, vol. 78.

Malisch, T. et al., "What You Should Know About Aneurysms," brochure, 6 pages.

Marsman, J.W.P. et al., "A Safe Technique for the Delivery of 'Mini' Gianturco Stainless Steel Coils," Diagnostic Imaging, 1981, pp. 43-46, vol. 50.

McAlister, D.S. et al., "Occlusion of Acquired Renal Arteriovenous Fistula With Transcatheter Electrocoagulation," AJR, Jun. 1979, pp. 998-1000, vol. 132.

Mehringer, C.M. et al., "Therapeutic Embolization for Vascular Trauma of the Head and Neck," AJNR, pp. 137-142, Mar.-Apr. 1983, vol. 4.

Murayama, Y. et al., "Ion Implantation: A New Experimental Approach to Surface Modification of Electrolytically Detachable Coils," 1 page.

Pevsner, Paul. "Micro-Balloon Catheter for Superselective Angiography and Therapeutic Occlusion," AMJR, Feb. 1977, pp. 225-230, vol. 128.

Phillips, J.F. et al., "Experimental Closure of Arteriovenous Fistula by Transcatheter Electrocoagulation," Diagnostic Radiology May 1975, pp. 319-321, vol. 115.

Phillips, J.F., "Transcatheter Electrocoagulation of Blood Vessels," Investigative Radiology, Sep.-Oct. 1973, pp. 295-304, vol. 8.

"Prowler Select: Microcatheter Select Performance," Cordis, 3 pages.

Quereshi, A.I. et al., "Endovascular Treatment of Intracranial Aneurysms by Using Guglielmi Detachable Coils in Awake Patients: Safety and Feasibility," Neurosurgery Focus, May 2001, pp. 1-6, vol. 10, No. 5.

"Renegade Fiber Braided Microcatheter," Boston Scientific Target, 1998, 4 pages.

Sadato, A. et al., "Treatment of a Spontaneous Carotid Cavernous Fistula Using an Electrodetachable Microcoil," AJNR, Mar./Apr. 1993, pp. 334-336, vol. 14.

"Seeker Flexible 16," Target Therapeutics, 1 page.

"Seeker Lite™—10 Steerable Guidewire," Target Therapeutics, 1 page.

"Seeker® Standard 14 Steerable Guidewire," Target Therapeutics, 1 page.

"Spinnaker™ 1.8F-L w/Hydrolene® Flow Directed Catheter," Target Therapeutics, 1 page.

Strother, C.M., "Electrothrombosis of Saccular Aneurysms Via Endovascular Approach: Part 1 and Part 2," Historical Perspective, AJNR, May 2001, pp. 1011-1012, vol. 22.

"Target Therapeutics: Recommended Start Up Products: Guglielmi Detachable Coil (GDC) (Investigational Device)," 1 page.

"Tracker®—18 Hi-Flow Infusion Catheter Applications," Target Therapeutics, 1 page.

"Tracker®—18 Hi-Flow Infusion Catheter Specifications," Target Therapeutics, 1 page.

"Tracker®Excel™—14 Microcatheter Engineered for GDC® Coil Delivery," Boston Scientific Target, 1998, 4 pages.

Abramson, H.A., "A Possible Relationship Between the Current of Injury and the White-Blood Cell in Inflammation," American J. Medical Sciences, 1924, pp. 702-711, vol. CLXVII.

"All Things Considered," of NPR, Jun. 28, 2000, Hour 1, pp. 10-20.

- Almgard, L.E. et al., "Embolic Occlusion of an Intrarenal Aneurysm: A Case Report," *British Journal of Urology*, 1973, pp. 485-486, vol. 45.
- "Amendment in 07/492,717," Aug. 7, 1991, pp. 8.
- "Amendment Under 37 C.F.R. § 1.111 in 08/147,529," Jun. 30, 1994, pp. 1-12.
- Amplatz, K., "A New, Simple Test for Thrombogenicity," *Radiology*, Jul.-Sep. 1976, pp. 53-55, vol. 120.
- Amplatz, K., "Vessel Occlusion With Transcatheter Electrocoagulation: Negative Results," pp. 253-255.
- Anderson, J. H. et al., "Mini Gianturco Stainless Steel Coils for Transcatheter Vascular Occlusion," *Radiology*, Aug. 1979, pp. 301-303, vol. 132, No. 2.
- Araki, C. et al., "Electrically Induced Thrombosis for the Treatment of Intracranial Aneurysms and Angiomas," *Proceedings of the Third International Congress of Neurological Surgery*, Aug. 23-27, 1965, pp. 651-654.
- Auger, R. G. et al., "Management of Unruptured Intracranial Aneurysms," *J. Stroke Cerebrovasc. Dis.*, 1991, pp. 174-181, vol. 1, No. 4.
- Ausman, J. I. et al., "Current Management of Cerebral Aneurysms: Is It Based on Facts or Myths?" *Surg. Neurol.*, 1985, pp. 625-634, vol. 24.
- Barth, K. H. et al., "Chronic Vascular Reactions to Steel Coil Occlusion Devices," *Am. J. Roentgenol.*, Sep. 1978, pp. 455-458, vol. 131.
- Bavinski, G. et al., "Gross and Microscopic Histopathological Findings in Aneurysms of the Human Brain Treated With Guglielmi Detachable Coils," *J. Neurosurg.*, Jul. 1999, pp. 284-293, vol. 91, No. 1.
- Bendok, B. et al., "Coil Embolization of Intracranial Aneurysms," *Neurosurgery*, May 2003, pp. 1125-1130, vol. 52, No. 5.
- Berenstein, A., "Embolization of Spinal Cord AVMS," 4 pages.
- Berenstein, A., "Tissue Response to Guglielmi Detachable Coils: Present Implications and Future Developments," *AJNR*, Apr. 1999, vol. 20.
- Billmeyer, F.W., "Textbook of Polymer Science," 1961, pp. 108-113.
- Blakemore, A. H. et al., "Electrothermic Coagulation of Aortic Aneurysms," *The Journal of the American Medical Association*, Oct. 1, 1938, pp. 1821-1827, vol. III, No. 20.
- Blakemore, A.H., "Progressive Constrictive Occlusion of the Abdominal Aorta With Wiring and Electrothermic Coagulation," *Annals of Surgery*, Jan.-Jun. 1951, pp. 447-462, vol. 133.
- Brendler, H. "Early Days of Urology at Mount Sinai," *Urology*, Jun. 1974, pp. 246-250, vol. III, No. 6.
- Brunelle, F. et al., "A Bipolar Electrode for Vascular Electrocoagulation With Alternating Current," *Radiology*, Oct.-Dec. 1980, pp. 239-240, vol. 137.
- Brunelle, F. et al., "Micro Stainless Steel Coils for Transcatheter Vascular Occlusion in Children," *Pediatr. Radiol.*, 1983, pp. 332-334, vol. 13.
- Bursch, J. H. et al., "Assessment of Arterial Blood Flow Measurement by Digital Angiography," *Radiology*, Oct. 1981, pp. 39-47, vol. 141.
- Butto, F. et al., "Coil-In-Coil Technique for Vascular Embolization," *Radiology*, Nov. 1986, pp. 554-555, vol. 161.
- Casasco, A. et al., "Percutaneous Transvenous Catheterization and Embolization of Vein of Galen Aneurysms," *Neurosurgery*, 1991, pp. 260-266, vol. 28.
- Casasco, A. E. et al., "Selective Endovascular Treatment of 71 Intracranial Aneurysms With Platinum Coils," *J. Neurosurg.*, 1993, pp. 3-10, vol. 79.
- Castaneda-Zuniga, W. R. et al., "Experimental Venous Occlusion With Stainless Steel Spiders," *Radiology*, Oct.-Dec. 1981, pp. 238-242, vol. 141.
- Castaneda-Zuniga, W. R. et al., "Nonsurgical Closure of Large Arteriovenous Fistulas," *JAMA*, Dec. 6, 1976, pp. 2649-2650, vol. 236, No. 23.
- Castaneda-Zuniga, W.R. et al., "A Rare Source of Pulmonary Embolization in Catheterization Procedures," *Radiology*, Oct.-Dec. 1981, pp. 237-242, vol. 141.
- Castaneda-Zuniga, W. R. et al., "Single Barbed Stainless Steel Coils for Venous Occlusion a Single But Useful Modification," *Investigative Radiology*, Mar.-Apr. 1982, pp. 186-188, vol. 17, No. 2.
- Castaneda-Zuniga, W. R. et al., "Therapeutic Embolization of Facial Arteriovenous Fistulae," *Radiology*, Jul.-Sep. 1979, pp. 599-602, vol. 132.
- Castel, J. C. et al., "Les Anevrysmes <<Hypergeants>> Intracraniens Sus-Tentoriels—Pieges Diagnostiques," *J. Neuroradiology*, 1985, pp. 135-149, vol. 12.
- Castro, E. et al., "Long-Term Histopathologic Findings in Two Cerebral Aneurysms Embolized With Guglielmi Detachable Coils," *AJRN*, Apr. 1999, pp. 549-552, vol. 20.
- Choi, I., "Spinal Cord Tumors," pp. 57-61.
- Chuang, V. P. et al., "A New Improved Coil for Tapered-Tip Catheter for Arterial Occlusion," *Radiology*, May 1980, pp. 507-509, vol. 135.
- Davis, P., "Southeastern Neuroradiological Society: 15th Annual Meeting, Oct. 2-6, 1991, Williamsburg, VA," *AJNR*, May/June. 1992, p. 1038, vol. 13.
- Debrun, G., "Dural AVM's of The Cavemous Sinus Region: Clinical Presentation, Angiographic Evaluation, Embolization and Complications," 2 pages.
- de los Reyes, R. A. et al., "Transcallosal, Transventricular Approach to a Basilar Apex Aneurysm," *Neurosurgery*, Sep. 1992, p. 397, vol. 31, No. 3.
- "Dendron Electrolytically Detachable Coils," Dendron GmbH, pp. 1-5, & Jul. 23, 2001.
- "Dendron Electrolytically Detachable Coil (EDC II) Package Info.," 8 pages.
- "Dendron New Positioning System for the EDC II and VDS: Technical Note," 2 pages.
- "Device for the Implantation of Occlusion Means," pp. 1-27.
- Disclosure of Expert Testimony of Dr. Randall T. Higashida Under Fed. R. Civ. P. 26(A)(2), 198 pages.
- Eskridge, J. M. et al., "Endovascular Embolization of 150 Basilar Tip Aneurysms With Guglielmi Detachable Coils: Results of the Food and Drug Administration Multicenter Clinical Trial," *J. Neurosurg.*, Jul. 1998, pp. 81-86, vol. 89.
- Formanek, A. et al., "Transcatheter Embolization (Interventive Radiology) In The Pediatric Age Group and Adolescent," *Annales De Radiologie Medecine Nucaire*, Jan.-Feb. 1979, pp. 150-159, No. 1.
- Fox, A., "Highlights of the First Congress of the World Federation of Interventional and Therapeutic Neuroradiology, Oct. 11-13, 1991, Zurich, Switzerland," pp. 1021-1023.
- Fox, A., "Notes on the Working Group in Interventional Neuroradiology," *AJNR*, Jan. 13-20, 1990, pp. 840-841, vol. 11.
- Frazer, H., "Balloons and Electricity: Treating Brain Aneurysms," *Diagnostic Imaging*, Jul. 1990, pp. 115-117.
- Gangarosa, E.J. et al., "Ristocetin-Induced Thrombocytopenia: Site and Mechanism of Action," *A.M.A. Archives of Internal Medicine*, 1960, pp. 83-89, vol. 105.
- Gelfand, D. W. et al., "Gastric Ulcer Scars," *Radiology*, Jul. 1981, pp. 37-43, vol. 140, No. 1.
- Gibbs, J., "Medical Device Investigations Understanding IRB and Informed Consent Requirements," *Medical Device & Diagnostic Industry*, Jun. 1989, pp. 103-106.
- Gold, R. F. et al., "Transarterial Electrocoagulation Therapy of a Pseudoaneurysm in the Head of the Pancreas," Oct. 1975, pp. 422-426.
- Goldman, M. L. et al., "Transcatheter Embolization With Bucrylate (In 100 Patients)," *RadioGraphics*, Aug. 1982, pp. 340-375, vol. 2, No. 3.
- Gomes, A.S. et al., "The Use of the Bristle Brush for Transcatheter Embolization," *Radiology*, Nov. 1978, pp. 345-350, vol. 129.
- Groeneveld, Y. G., "Rapport Inzake EP-484.468 & EP-800.790 & EP-804.905 Niet-inbreuk & Ongeldigheid," 43 pages.
- Guarda, F. et al., "Histological Reactions of Porous Tip Endocardial Electrodes Implanted in Sheep," pp. 267-273.
- Guglielmi, G. et al., "Carotid-Cavernous Fistula Caused by a Ruptured Intracavernous Aneurysm: Endovascular Treatment by Electrothrombosis With Detachable Coils," *Neurosurgery*, Sep. 1992, pp. 591-597, vol. 31, No. 3.
- Guglielmi, G. et al., "Detachable Microcoils in the Endovascular Treatment of Intracranial Aneurysms; Preliminary Clinical Experience."

- Guglielmi, G. et al., "Electrothrombosis of Saccular Aneurysms Via Endovascular Approach, Part 2" *J. Neurosurg.*, 1991, pp. 8-14, vol. 75.
- Guglielmi, G., "Endovascular Treatment of Intracranial Aneurysms," *Interventional Neuroradiology*, May 1992, pp. 269-278, vol. 2, No. 2.
- Guglielmi, G. et al., "Endovascular Treatment of Intracranial Saccular Aneurysms With Detachable Coils and Electrothrombosis: Experience With 39 Cases," 1992 AANS Annual Meeting San Francisco, CA, Apr. 11-16, 1992.
- Guglielmi, G., "In Re: Radiologic and Histopathology Evaluation of Canine Artery Occlusion After Collagen-Coated Platinum Microcoil Delivery," *Letters*, p. 607.
- Guglielmi, G., "Generations of Guglielmi Detachable Coils," *AJNR*, Jun. 1997, p. 1195, vol. 16.
- Gyo, K., "Histological Study of Chronic Electrode Implantation Through the Round Window of the Guinea Pig," *Acta Otolaryngol (Stockh)*, 1988, pp. 248-254, vol. 105.
- Halbach, V. V. et al., "Embolization of Brain AVMS With Particles," 4 pages.
- Halbach, V. V. et al., "Paper 221: Metallic Fragment Emboli Resulting From Treatment With Electrolytically Detachable Coils (GDC)," *Proceedings of the American Society of Neuroradiology (ASNR)*, May 3-7, 1994, pp. 155-156.
- Xinan, H., "Transcatheter Electrocoagulation: A Preliminary Experimental Study," *Chinese Journal of Radiology*, Apr. 1987, pp. 241-245.
- Xinan, H. et al., "Vascular Embolization Utilizing Transcatheter Electrocoagulation In Combination With Steel Coil: An Experimental Study," *Chinese Journal of Radiology*, Mar. 1988, pp. 180-183.
- Han, M. et al., "Gas Generation and Clot Formation During Electrolytic Detachment of Guglielmi Detachable Coils: In Vitro Observations and Animal Experiment," *AJNR*, Mar. 2003, pp. 539-544, vol. 24.
- Handley, D. A. et al., "Colloidal Gold Labeling Studies Related to Vascular and Endothelial Function, Hemostasis and Receptor-Mediated Processing of Plasma Macromolecules," *European Journal of Cell Biology*, 1987, pp. 163-174, vol. 43.
- Hanner, J. et al., "Gianturco Coil Embolization of Vein of Galen Aneurysms: Technical Aspects," *RadioGraphics*, Sep. 1988, pp. 935-946, vol. 8, No. 5.
- Heilman, C. B. et al., "Elimination of a Cirroid Aneurysm of the Scalp by Direct Percutaneous Embolization With Thrombogenic Coils," *J. Neurosurg.*, 1990, pp. 296-300, vol. 73.
- Heros, R. C., "Intracranial Aneurysms," *Minnesota Medicine*, Oct. 1990, pp. 27-32, vol. 73.
- Hieshima, G. B. et al., "Intracranial Embolotherapy: Plugging Aneurysms With Balloons," *Diagnostic Imaging*, 1986.
- Hilal, S. K. et al., "Endovascular Treatment of Aneurysms With Coils," *J. Neurosurg.*, Feb. 1992, pp. 337-339, vol. 76.
- Hilal, S. K. et al., "Synthetic Fiber-Coated Platinum Coils Successfully Used for the Endovascular Treatment of Arteriovenous Malformations, Aneurysms and Direct Arteriovenous Fistulas of the CNS," *ASNR Twenty-Sixth Annual Meeting*, May 15-20, 1988, pp. 224-225.
- Hodes, J. E. et al., "Endovascular Occlusion of Intracranial Vessels for Curative Treatment of Unclippable Aneurysms: Report of 16 Cases," *J. Neurosurg.*, 1991, pp. 694-701, vol. 75.
- Horowitz, M. B. et al., "Scanning Electron Microscopic Findings in a Basilar Tip Aneurysm Embolized With Guglielmi Detachable Coils," *AJNR*, Apr. 1997, pp. 688-690, vol. 18.
- Huckman, M., "Founding of the Mexican Society of Diagnostic and Therapeutic Neuroradiology (SMNR)," *AJNR*, May/June 1992, pp. 1024-1026, vol. 13.
- Huckman, M. et al., "Highlights of the 28th Annual Meeting of the American Society of Neuroradiology, Los Angeles, Mar. 19-23, 1990," *AJNR*, Sep./Oct. 1990, pp. 1057-1068.
- Huckman, M. et al., "Meeting Summaries, XIVth Symposium Neuroradiologicum: Jun. 17-23, 1990, the Queen Elizabeth Centre, London," *AJNR*, Nov./Dec. 1990, pp. 1273-1279, vol. 11.
- Ison, K. T., "Platinum and Platinum/Iridium Electrode Properties When Used for Extracochlear Electrical Stimulation of the Totally Deaf," *Medical & Biological Engineering & Computing*, Jul. 1987, pp. 403-413, vol. 25.
- Kassell, N. F. et al., "The International Cooperative Study on the Timing of Aneurysm Surgery," *J. Neurosurg.*, 1990, pp. 18-36, vol. 73.
- Kassell, N. F. et al., "Timing of Aneurysm Surgery," *Neurosurgery*, 1982, pp. 514-519, vol. 10.
- Kichikawa, K. et al., "Iliac Artery Stenosis and Occlusion: Preliminary Results of Treatment With Gianturco Expandable Metallic Stents," *Radiology*, pp. 799-802, vol. 177, No. 3.
- Lammer, J., "Biliary Endoprotheses," *Radiologic Clinics of North America*, Nov. 1990, pp. 1211-1222, vol. 28, No. 6.
- Lane, B. et al., "Coil Embolization of an Acutely Ruptured Saccular Aneurysm," *AJNR*, Nov./Dec. 1991, pp. 1067-1069, vol. 12.
- Leonardi, M., "A History of Neuroradiology in Italy," *AJNR*, Apr. 1996, pp. 721-730, vol. 17.
- Linton, R., "Intrasaccular Wiring of Abdominal Arteriosclerotic Aortic Aneurysms by the "Pack" Method," *Angiology*, 1951, pp. 485-498, vol. II.
- Linton, R. et al., "Treatment of Thoracic Aortic Aneurysms by the "Pack" Method of Intrasaccular Wiring," *The New England Journal of Medicine*, Jan.-Jun. 1952, pp. 847-855, vol. 246.
- Ljunggren, B. et al., "Early Management of Aneurysmal Subarachnoid Hemorrhage," *Neurosurgery*, 1981, pp. 412-418, vol. 11, No. 3.
- Loucks, R. B. et al., "The Erosion of Electrodes by Small Currents," *Electroencephalography and Clinical Neurophysiology*, 1959, pp. 823-826, vol. IX.
- Lozier, A. P. et al., "Guglielmi Detachable Coil Embolization of Posterior Circulation Aneurysms," *Stroke*, Oct. 2002, pp. 2509-2518.
- Lund, G. et al., "Detachable Stainless-Steel Spider," *Radiology*, Aug. 1983, pp. 567-568, vol. 148, No. 2.
- Ljunggren, B. et al., "Early Operation and Overall Outcome in Aneurysmal Subarachnoid Hemorrhage," *J. Neurosurg.*, Apr. 1985, pp. 547-551, vol. 62.
- Manabe, H. et al., "Embolisation of Ruptured Cerebral Aneurysms With Interlocking Detachable Coils in Acute Stage," *Interventional Neuroradiology*, 1997, pp. 49-63, vol. 3.
- Marshall, M. W. et al., "Ferromagnetism and Magnetic Resonance Artifacts of Platinum Embolization Microcoils," *Cardiovasc. Intervent. Radiol.*, 1991, pp. 163-166, vol. 14.
- Mazer, M. J. et al., "Therapeutic Embolization of the Renal Artery With Gianturco Coils: Limitations and Technical Pitfalls," *Radiology*, Jan. 1981, pp. 37-46, vol. 138.
- McConnell, A. A., "Subchiasmatal Aneurysm Treated by Implantation of Muscle," *Zentralblatt Fur Neurochirurgie*, 1937, pp. 269-274, No. 5-6.
- McDermott, J. C. et al., "Review of the Uses of Digital Roadmap Techniques in Interventional Radiology," *CIRSE-SCVIR*, Jun. 12-17, 1988, pp. 11-13.
- McDougall, C.G. et al., "Causes and Management of Aneurysmal Hemorrhage Occurring During Embolization With Guglielmi Detachable Coils," *J. Neurosurg.*, 1998, pp. 87-92, vol. 89.
- McDougall, C. G. et al., "Endovascular Treatment of Basilar Tip Aneurysms Using Electrolytically Detachable Coils," *J. Neurosurg.*, Mar. 1996, pp. 393-399, vol. 84.
- McKissock, W., "Anterior Communicating Aneurysms a Trial of Conservative and Surgical Treatment," *The Lancet*, Apr. 24, 1965, pp. 873-876.
- MDR Database, Brand Name Flex-Tip Guidewire and Tracker Hi-Flow, 1998, Access No. M162232.
- Micropaw 20 Micro-Plasma Welding Systems, 1 page.
- Miller, D.L., "Arterial Occlusion With Coils," *Arch. Intern. Med.*, Sep. 1985, p. 1737, vol. 145.
- Mizoi, K. et al., "A Pitfall in the Surgery of a Recurrent Aneurysm After Coil Embolization and its Histological Observation: Technical Case Report" *Neurosurgery*, Jul. 1996, vol. 39, No. 1.
- Molyneux, A. J. et al., "Histological Findings in Giant Aneurysms Treated With Guglielmi Detachable Coils," *J. Neurosurg.*, 1995, pp. 129-132, vol. 83.
- Morag et al., "The Role of Spermatic Venography After Surgical High Ligation of the Left Spermatic Veins: Diagnosis and Percutaneous Occlusion," *Urologic Radiology*, 1985, pp. 32-34, vol. 7.
- Mullan, S. et al., "Simplified Thrombosis of a Large, Hypertrophic Hemangioma of the Scalp," *J. Neurosurg.*, 1964, pp. 68-72, vol. XXI.

- Murayama, Y. et al., "Guglielmi Detachable Coil Embolization of Cerebral Aneurysms: 11 Years' Experience," *J. Neurosurg.*, 2003, pp. 959-966, vol. 98.
- Nahser, H. C. et al., "Okklusion Von Aneurysmata Mit Platincoils," *Neuroradiologie des Alfred-Krupp-Krankenhauses*, pp. 203-207.
- Nakahara, I. et al., "Endovascular Coil Embolization of a Recurrent Giant Internal Carotid Artery Aneurysm Via a Posterior Communicating Artery After Cervical Carotid Ligation: Case Report," *Surg. Neurol.*, 1992, pp. 57-61, vol. 38.
- Nakahara, I. et al., "Treatment of Giant Anterior Communicating Artery Aneurysm Via An Endovascular Approach Using Detachable Balloons and Occlusive Coils," *AJNR*, Nov./Dec. 1990, pp. 1195-1197, vol. 11.
- Nancarrow, P. A. et al., "Stability of Coil Emboli: An In Vitro Study," *Cardiovasc. Intervent. Radiol.*, 1987, pp. 226-229, vol. 10.
- NASA Tech Briefs; "Implantable Electrode for Critical Locations," Aug. 1990, p. 74.
- Nishioka H. et al., "Cooperative Study of Intracranial Aneurysms and Subarachnoid Hemorrhage: A Long-Term Prognostic Study," *Arch. Neurol.*, Nov. 1984, vol. 41.
- Numoguchi, Y. et al., "Platinum Coil Treatment of Complex Aneurysms of the Vertebrobasilar Circulation," *Neuroradiology*, 1992, pp. 252-255, vol. 34.
- O'Reilly, G. V. et al., "Transcatheter Fiberoptic Laser Coagulation of Blood Vessels," *Radiology*, Mar. 1982, pp. 777-779, vol. 142, No. 3.
- Okazaki, M. et al., "A Coaxial Catheter and Steerable Guidewire Used to Embolize Branches of the Splanchnic Arteries," *AJR*, Aug. 1990, pp. 405-406, vol. 155.
- Padolecchia, R. et al., "Role of Electrothrombosis in Aneurysm Treatment With Guglielmi Detachable Coils: An In Vitro Scanning Electron Microscopic Study," *AJNR*, Oct. 2001, pp. 1757-1760, vol. 22.
- Pakarinen, S., "Incidence, Aetiology and Prognosis of Primary Subarachnoid Haemorrhage," *Acta Neurologica Scandinavica*, 1967, pp. 9-128, Supplementum 29, vol. 43.
- Parsonnet, V. et al., "Corrosion of Pacemaker Electrodes," *Pace*, May-Jun. 1981, pp. 289-297, vol. 4.
- Peerless, S. J. et al., "Giant Intracranial Aneurysms," *Vascular Disease*, Chapter 57, 1987, pp. 1742-1763.
- Peterson, E. W. et al., (abstract) "291. Electrically Induced Thrombosis of the Cavernous Sinus in the Treatment of Carotid Cavernous Fistula," *Fourth International Congress of Neurological Surgery Ninth International Congress of Neurology*, Sep. 20-27, 1969, p. 105.
- Probst, P. et al., "Nonsurgical Treatment of Splenic-Artery Aneurysms," *Radiology*, Jul.-Sep. 1978, pp. 619-623, vol. 128.
- Probst, P. et al., "Which Embolic Material is Best Suited for Which Embolization Procedure?" *Fortschr. Rontgenstr.*, 1978, pp. 447-454, vol. 129, No. 4.
- Quinn, S. F. et al., "Complications From 0.018-in. Floppy Platinum-Tip Guidewires," *AJR*, May 1990, pp. 1103-1104, vol. 154.
- Ralston, M. D. et al., "Effect of Increasing Current and Decreasing Blood Flow for Transcatheter Electrocoagulation (TCEC)," *Investigative Radiology*, Mar.-Apr. 1982, pp. 171-177, vol. 17, No. 2.
- Rao, V. R. et al., "Embolization of Large Saccular Aneurysms With Gianturco Coils," *Radiology*, 1990, pp. 407-410, vol. 175.
- "Reaction to the Inventive Step Arguments From the Groeneveld Report of Nov. 4, 2002 on EP-B-0 484 468, EP-B-0 800 790, EP-B-0 804 905 in the case EV3 et al. / The Regents & Boston," 11 pages.
- "Replication of the Thompson et al. Transcatheter Electrocoagulation Experimental Evaluation of the Anode Experiments," Apr. 30, 2003, 16 pages.
- Reul, J. et al., "Long-Term Angiographic and Histopathologic Findings in Experimental Aneurysms of the Carotid Bifurcation Embolized With Platinum and Tungsten Coils," *AJNR*, Jan. 1997, pp. 35-42, vol. 18.
- Rodriguez, F., "Principles of Polymer Systems," Second Edition, 1982, pp. 534-537.
- Rufenacht, D. et al., "Principles and Methodology of Intracranial Endovascular Access," *Interventional Neuroradiology*, May 1992, pp. 251-268, vol. 2, No. 2.
- Ruscalleda, J. et al., "Neuroradiological Features of Intracranial and Intraorbital Meningeal Haemangiopericytomas," *Neuroradiology*, 1994, pp. 440-445, vol. 36.
- Russell, E., "Highlights of The Scientific Exhibits of the 29th Annual Meeting of the American Society of Neuroradiology, Washington, D.C., Jun. 9-14, 1991," pp. 1251-1257.
- Sadato, A. et al., "Immediately Detachable Coil for Aneurysm Treatment," *AJNR*, Aug. 1995, pp. 1459-1462, vol. 16.
- Salazar, A. E., "Experimental Myocardial Infarction," *Circulation Research*, Nov. 1961, vol. IX.
- Samuelsson, L. et al., "Electrocoagulation," *Acta Radiologica Diagnosis*, 1982, pp. 459-462, vol. 23.
- Samuelsson L. et al., "Electrolytic Destruction of Tissue in the Normal Lung of the Pig," *Acta Radiologica Diagnosis*, 1981, pp. 9-14, vol. 22.
- Sawyer, P. N. et al., "Electrical Potential Differences Across the Normal Aorta and Aortic Grafts of Dogs," *Am. J. Physiol.*, Oct. 1953, pp. 113-117, vol. 175.
- Serbinenko, F. A., "Balloon Catheterization and Occlusion of Major Cerebral Vessels," *J. Neurosurg.*, Aug. 1974, vol. 41.
- Setton, A. et al., "Interventional Neuroradiology," *Current Opinion in Neurology and Neurosurgery*, 1992, pp. 870-880, vol. 5.
- Shah, P. M. et al. "Pseudoaneurysm of Anterior Tibial Artery After Occlusion From Blunt Trauma: Nonoperative Management," *The Journal of Trauma*, 1985, pp. 656-657, vol. 25, No. 7.
- Shimizu, S. et al., "Tissue Response of a Small Saccular Aneurysm After Incomplete Occlusion With a Guglielmi Detachable Coil," *AJNR*, Apr. 1999, pp. 546-548, vol. 20.
- Sorteberg, A. et al., "Effect of Guglielmi Detachable Coils on Intraaneurysmal Flow: Experimental Study in Canines," *AJNR*, Feb. 2002, pp. 288-294, vol. 23.
- Sosman, M. C. et al., "Aneurysms of the Internal Carotid Artery and the Circle of Willis, From a Roentgenological Viewpoint," *The American Journal of Roentgenology and Radium Therapy*, Jan.-Jun. 1926, vol. XV.
- Steiner, L., "Gamma Knife Radiosurgery in Arteriovenous Malformations of the Brain," 6 pages.
- Strother, C., "Electrothrombosis of Saccular Aneurysms Via Endovascular Approach Part 1 and Part 2," *AJNR*, May 2001, pp. 1010-1012, vol. 22.
- Taki, W. et al., "Balloon Embolization of a Giant Aneurysm Using a Newly Developed Catheter," *Surg. Neurol.*, Nov. 1979, pp. 363-365, vol. 12.
- Taki, W. et al., "Radiopaque Solidifying Liquids for Releasable Balloon Technique: A Technical Note," *Surg. Neurol.*, Feb. 1980, pp. 140-142, vol. 13.
- Terbrugge, K., "Duram AVMs of the Posterior Fossa: Clinical Presentation, Classification, Angiographic Evaluation and Treatment," 4 pages.
- "Third Amendment After Final in 10/170,897," Dec. 2, 2002, 4 pages.
- Thompson, W. M. et al., "Vessel Occlusion With Transcatheter Electrocoagulation," *Cardiovasc. Intervent. Radiol.*, 1980, pp. 244-255, vol. 3, No. 4.
- Thompson, W. M. et al., "Vessel Occlusion With Transcatheter Electrocoagulation: Initial Clinical Experience," *Radiology*, Oct.-Dec. 1979, pp. 335-340, vol. 133.
- Tragardh, Bengi et al., "Intravascular Electrically Induced Thrombosis in the Dog," *Radiology*, Oct.-Dec. 1976, pp. 55-56, vol. 121.
- Vinuela, F. et al., "Electrolytically Detachable Microcoils," *AJNR*, Mar./Apr. 1993, pp. 337-339, vol. 14.
- Vinuela, F. et al., "Embolization of Brain AVMs With Liquids," 4 pages.
- Wallace, S. et al., "Steel Coil Embolus and its Therapeutic Applications," *Abrams Angiography*, 1983, pp. 2151-2173, Third Edition, vol. III.
- Werner, S. C. et al., "Aneurysm of the Internal Carotid Artery Within the Skull," *The Journal of the American Medical Association*, Jan.-Jun. 1941, pp. 578-582, vol. 116.
- Wiebers, D. O. et al., "Impact of Unruptured Intracranial Aneurysms on Public Health in the United States," *Stroke*, Oct. 1992, pp. 1416-1419, vol. 23, No. 10.

- Wiebers, D. O. et al., "The Significance of Unruptured Intracranial Saccular Aneurysms," *J. Neurosurg.*, Jan. 1987, pp. 23-29, vol. 66.
- White Jr., R. I. et al., "Therapeutic Embolization With Long-Term Occluding Agents and Their Effects on Embolized Tissues," *Radiology*, Dec. 1977, pp. 677-687, vol. 125.
- Workman, M. et al., "Thrombus Formation at the Neck of Cerebral Aneurysms During Treatment With Guglielmi Detachable Coils," *Ajnr*, Oct. 2002, pp. 1568-1576, vol. 23.
- Yoneda, S. et al., "Electrothrombosis of Arteriovenous Malformation," *Neurologia Medico-Chirurgica*, 1997, pp. 19-28, vol. 17, Part I, No. 1.
- Yoneda, S. et al., "Treatment of Spontaneous Carotid-Cavernous Fistula," *Neurol. Med. Chir.*, 1979, pp. 141-147, vol. 10.
- Yoshida, K., "Experimental Studies on the Production and Treatment of the Carotid Thrombosis in Dogs," *Archiv fur Japanische Chirurgie*, May 1964, pp. 502-524, vol. 33, No. 3.
- Yuen, T. G. H. et al., "Tissue Response to Potential Neuroprosthetic Materials Implanted Subdurally," *Biomaterials*, Mar. 1987, pp. 138-140, vol. 8.
- Zollikofer, C. et al., "A Combination of Stainless Steel Coil and Compressed Ivalon: A New Technique for Embolization of Large Arteries and Arteriovenous Fistulas," *Radiology*, Jan.-Mar. 1981, pp. 229-231, vol. 138.
- U.S. Appl. No. 07/840,211, filed Feb. 24, 1992, Guglielmi et al.
- Alksne et al., "Stereotaxic Occlusion of 22 Consecutive Anterior Communicating Artery Aneurysms," *J. Neurosurg.*, 1980, pp. 790-793, vol. 52.
- Anderson et al., "Transcatheter Intravascular Coil Occlusion of Experimental Arteriovenous Fistulas," *Am. J. Roentgenology*, Oct./Nov. 1977, pp. 795-798, vol. 129.
- Araki et al., "Electrically Induced Thrombosis for the Treatment of Intracranial Aneurysms and Angiomas," Department of Neurosurgery, Kyoto University Medical School, Kyoto, Japan, pp. 651-654.
- ASNR Section, Highlights of the 28th Annual Meeting of the American Society of Neuroradiology, Los Angeles, CA, Mar. 19-23, pp. 1057-1069, 1990.
- Braun et al., "Use of Coils for Transcatheter Carotid Occlusion," *AJNR*, Dec. 1985, pp. 953-956, vol. 6.
- Byrne et al., "The Nature of Thrombosis Induced by Platinum and Tungsten Coils in Saccular Aneurysms," *AJNR*, 1997, pp. 29-33, vol. 18.
- Castaneda-Zuniga et al., "A New Device for the Safe Delivery of Stainless Steel Coils," *Radiology*, Jul. 1980, pp. 230-231, vol. 136.
- Claiborne Johnston et al., "Recommendations for the Endovascular Treatment of Intracranial Aneurysms," *Stroke*, 2002, pp. 2536-2544, vol. 33.
- Cook Catalog with Hilal-Coils, 1988, pp. 1-5.
- Cragg et al., "Nonsurgical Placement of Arterial Endoprostheses: A New Technique Using Nitinol Wire," *Radiology*, Apr. 1983, pp. 261-263, vol. 147.
- Debrun et al., "Detachable Balloon and Calibrated-leak balloon techniques in the treatment of cerebral vascular lesions," *J. Neurosurg.*, 1978, pp. 635-649, vol. 49.
- Donauer et al., "Intracranial Aneurysms: The surgical and Endovascular Approach," Dendron, 2002, Lanzer and Topol eds., Springer Verlag, pp. 1154-1216.
- Dovey et al., "Guglielmi Detachable Coiling for Intracranial Aneurysms," *Arch Neurol.*, 2001, pp. 559-564, vol. 58.
- Dowd et al., "Endovascular Coil Embolization of Unusual Posterior Inferior Cerebellar Artery Aneurysms," *Neurosurgery*, 1990, pp. 954-961, vol. 27.
- Gianturco et al., "Mechanical Devices for Arterial Occlusion," *Am. J. Roentgenology Radium Therapy and Nuclear Medicine (AJR)*, 1975, pp. 428-435, vol. 124.
- Graves et al., "Treatment of Carotid Artery Aneurysms With Platinum Coils: An Experimental Study In Dogs," *AJNR*, 1990, pp. 249-252, vol. 11.
- Guerrisi et al., "L'elettrotrombosi Intravasale Nelle Malformazioni Vascolari Sperimentalmente Provocate," Proceedings of the Bari Congress, Sep. 29/30, 1983, pp. 139-146, translation included.
- Guglielmi, G., "Historical Note," *AJNR*, 2002, p. 342, vol. 23.
- Guglielmi, G., "Embolization of Intracranial Aneurysms With Detachable Coils and Electrothrombosis," *Interventional Neuroradiology: Endovascular Therapy of the Central Nervous System*, Ed. F. Vinuela et al. Raven Press, New York, 1992, pp. 63-75.
- Guglielmi et al., "Electrothrombosis of Saccular Aneurysms Via Endovascular Approach, Part 1: Electrochemical Basis, Technique, and Experimental Results," *J. Neurosurg.*, 1991, pp. 1-7, vol. 75.
- Guglielmi et al., "Electrothrombosis of Saccular Aneurysms Via Endovascular Approach, Part 2: Preliminary Clinical Experience," *J. Neurosurg.*, 1991, pp. 8-14, vol. 75.
- Hanner et al., "Gianturco Coil Embolization of Vein of Galen Aneurysms: Technical Aspects," *Radiographics*, Sep. 1988, pp. 935-946, vol. 8, No. 5.
- Hawkins et al., "Retrievable Gianturco-Coil Introducer," *Radiology*, Jan. 1986, pp. 262-264.
- Higashida et al., "Interventional Neurovascular Treatment of a Giant Intracranial Aneurysm Using Platinum Microcoils," *Surg. Neurol.*, Jan. 1991, pp. 64-68, vol. 35, No. 1.
- Hilal et al., "Synthetic Fiber-Coated Platinum Coils Successfully Used for the Endovascular Treatment of Arteriovenous Malformations, Aneurysms and Direct Arteriovenous Fistulas of the CNS," 26th Annual Meeting, Session 10G, Paper 175, 1988.
- Hilal Coils in Cook Incorporated Catalog, 1988, 9 pages.
- Horowitz et al., "Does Electrothrombosis Occur Immediately After Embolization of an Aneurysm With Guglielmi Detachable Coils," *AJNR*, 1997, pp. 510-513, vol. 18.
- Hosobuchi, Y., "Electrothrombosis of Carotid-Cavernous Fistula," *J. Neurosurg.*, Jan. 1975, pp. 76-85, vol. 42.
- Hunner, G.L., "Aneurysm of the Aorta Treated by the Insertion of a Permanent Wire and Galvanism Moore-Corradi Method," *Bulletin of the Johns Hopkins Hospital*; 1900, pp. 263-279, vol. XI, No. 116.
- Ji et al., "Endovascular Electrocoagulation: Concept, Technique, and Experimental Results," *AJNR*, 1997, pp. 1669-1678, vol. 18.
- Konishi et al., "Congenital Fistula of the Dural Carotid-Cavernous Sinus: Case Report and Review of the Literature," *Neurosurgery*, 1990, pp. 120-125, vol. 27, No. 1.
- Lund et al., "Detachable Steel Spring Coils for Vessel Occlusion," *Radiology*, May 1985, p. 530, vol. 155.
- Lylyk et al., "Therapeutic Alternatives for Vein of Galen Vascular Malformations," *J. Neurosurg.*, Mar. 1993, pp. 438-445, vol. 78.
- Marsman et al., "A Safe Technique for the Delivery of 'Mini' Gianturco Stainless Steel Coils," *Diagnostic Imaging*, 1981, pp. 43-46, vol. 50.
- McAlister et al., "Occlusion of Acquired Renal Arteriovenous Fistula With Transcatheter Electrocoagulation," *Am. J. Roentgenol.*, Jun. 1979, pp. 998-1000, vol. 132.
- McAlister et al., "Transcatheter Electrocoagulation of the Pulmonary Artery: An Experimental Model in Dogs for Studying Pulmonary Thrombosis," *Invest Radiol.*, 1981, pp. 289-297, vol. 16.
- MDR Database, Brand Name Target Therapeutics, 1990, Access No. M183708.
- MDR Database, Brand Name Target Therapeutics Tracker 18 LF Catheter, 1990, Access No. M220254.
- MDR Database, Brand Name Target Therapeutics Tracker 18 Catheter, 1991, Access No. M235647.
- MDR Database, Brand Name Tracker 18 Dual Marker, Jan. 1992, Access No. M264109.
- MDR Database, Brand Name Target Therapeutics Coil Pusher 16, Jan. 1990, Access No. M183709.
- MDR Database, Brand Name Target Therapeutics Coil Pusher 16, Dec. 1989, Access No. M181514.
- MDR Database, Brand Name 10 Unibody Infusion Catheter, May 1991, Access No. M231556.
- MDR Database, Brand Name Target Therapeutics Tracker 18 Unibody Catheter, Oct. 1991, Access No. M246650.
- Miller et al., "Clinical Use of Transcatheter Electrocoagulation," *Radiol.*, 1978, pp. 211-214, vol. 129.
- Morse et al., "Platinum Microcoils for Therapeutic Embolization: Nonneuroradiologic Applications," *AJR*, 1990, pp. 401-403, vol. 155.
- Mullan et al., "Electrically Induced Thrombosis in Intracranial Aneurysms," *J. Neurosurg.*, Jan.-Jun. 1965, pp. 539-547, vol. 22.

- Mullan, S., "Experiences with Surgical Thrombosis of Intracranial Berry Aneurysms and Carotid Cavernous Fistulas," *J. Neurosurg.*, 1974, pp. 657-670, vol. 41.
- Mullan et al., "Stereotactic Copper electric Thrombosis of Intracranial Aneurysms," *Progr. Neurol. Surg.*, 1969, pp. 193-211, vol. 2.
- Ovitt et al., "Guide Wire Thrombogenicity and its Reduction," *Radiology*, 1974, pp. 43-46, vol. 111, No. 1.
- Phillips, J., "Transcatheter Electrocoagulation of Blood Vessels," *Invest Rad.*, 1973, pp. 295-304, vol. 8.
- Philpott et al., "The Mechanism of Transcatheter Electrocoagulation (TCEC)," *Investigative Radiology*, 1983, pp. 100-104, vol. 18.
- Piton et al., "Selective Vascular Thrombosis Induced by a Direct Electrical Current: animal experiments," *J. Neuroradiology*, 1978, pp. 139-152, vol. 5.
- Piton et al., "Vascular Thrombosis Induced by Direct Electrical Current," *Neuroradiology*, 1978, pp. 385-388, vol. 16.
- Piton et al., "Embolisation Par Courant Electrique Continu : ECEC," *J. Radiol.*, 1979, pp. 799-808, vol. 60, No. 12 (including English translation).
- Qureshi et al., "Endovascular Treatment of Intracranial Aneurysm by Using Guglielmi Detachable Coils in Awake Patients: Safety and Feasibility," *Neurosurg. Focus*, 2001, pp. 1-6, vol. 10, No. 5.
- Sadato et al., "Treatment of a Spontaneous Carotid Cavernous Fistula Using an Electrodetachable Microcoil," *AJNR*, 1993, pp. 334-336, vol. 14.
- Sawyer et al. "Bio-Electric Phenomena as an Etiological Factor in Intravascular Thrombosis," *Am. J. Physiol.*, 1953, pp. 103-107, vol. 175.
- Serbinenko, F., "Balloon Catheterization and Occlusion of Major Cerebral Vessels," *J. Neurosurg.*, 1974, pp. 125-145, vol. 41.
- Strother, C. ed., "Electrothrombosis of Saccular Aneurysms Via Endovascular Approach: Part 1 and Part 2", *AJNR*, 2002, pp. 1011-1012, vol. 22.
- Taki et al., "Selection and Combination of Various Endovascular Techniques in the Treatment of Giant Aneurysms," *J. Neurosurg.*, 1992, pp. 37-42, vol. 77.
- Taki et al., "Radiopaque Solidifying Liquids for Releasable Balloon Technique: A Technique Note," *Surg. Neurol.*, 1980, pp. 140-142, vol. 13.
- Target Therapeutics Catalogue 1993-95, 1997, 2003.
- Target Therapeutics, "History of the Guglielmi Detachable Coil," *History of the GDC*, Oct. 1995, pp. 1-6.
- Thompson et al., "Transcatheter Electrocoagulation: A Therapeutic Angiographic Technique for Vessel Occlusion," *Invest. Radiol.*, 1977, pp. 146-153, vol. 12.
- Thompson et al., "Transcatheter Electrocoagulation: Experimental Evaluation of the Anode," *Invest. Radiol.*, 1979, pp. 41-47, vol. 14.
- Thompson et al., "Vessel Occlusion With Transcatheter Electrocoagulation," *Cardio Vasc. Intervent. Radiol.*, 1980, pp. 244-253, vol. 3.
- Thompson et al., "Vessel Occlusion With Transcatheter Electrocoagulation: Initial Clinical Experience," *Radiol.*, 1979, pp. 335-340, vol. 133.
- Wallace et al., "Therapeutic Vascular Occlusion Utilizing Steel Coil Technique: Clinical Applications," *American J. Roentgenology*, 1976, pp. 381-387, vol. 127.
- Yang et al., "Platinum Wire: A New Transvascular Embolic Agent," *AJNR*, May/Jun. 1988, pp. 547-550, vol. 9.

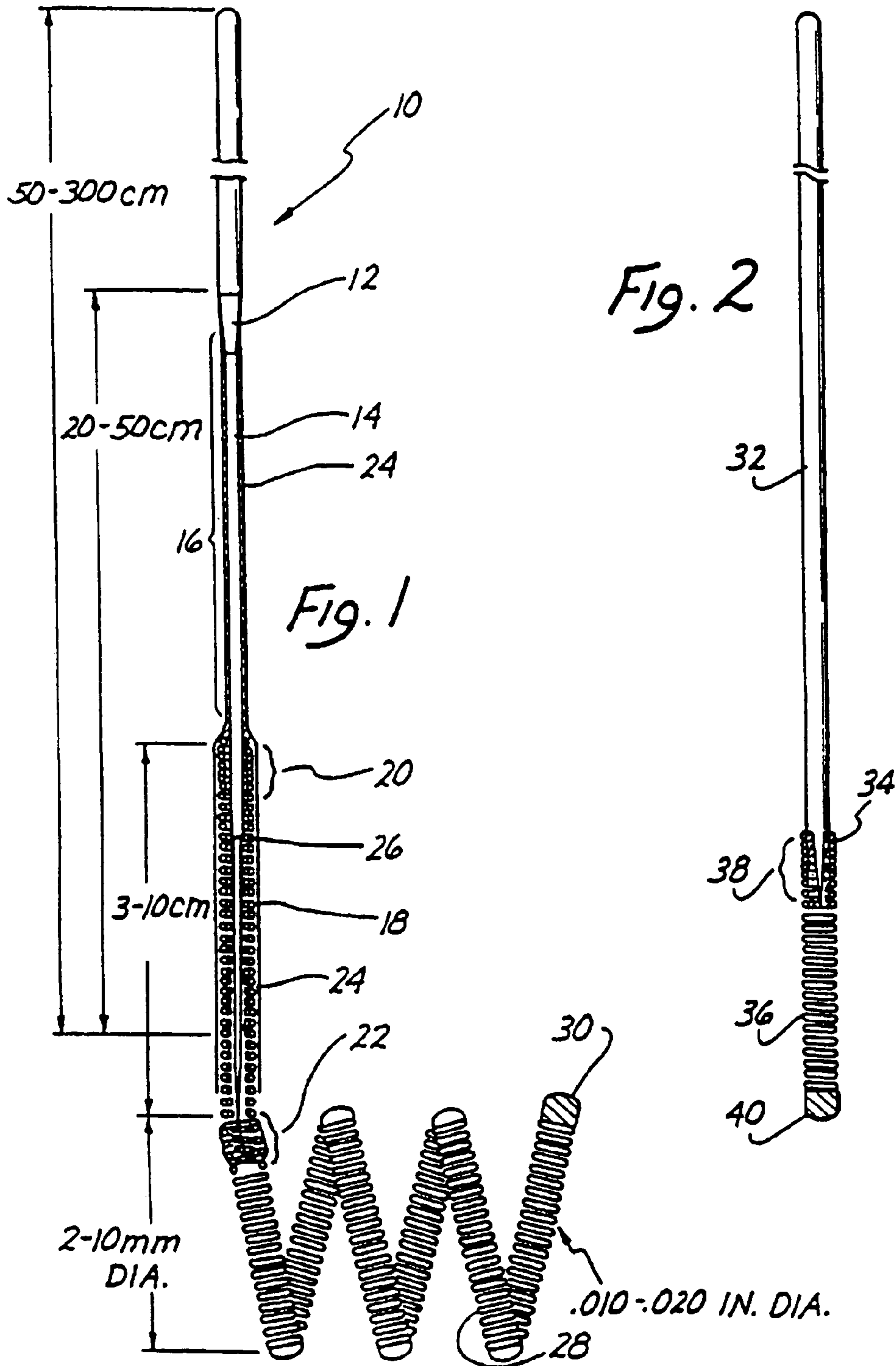

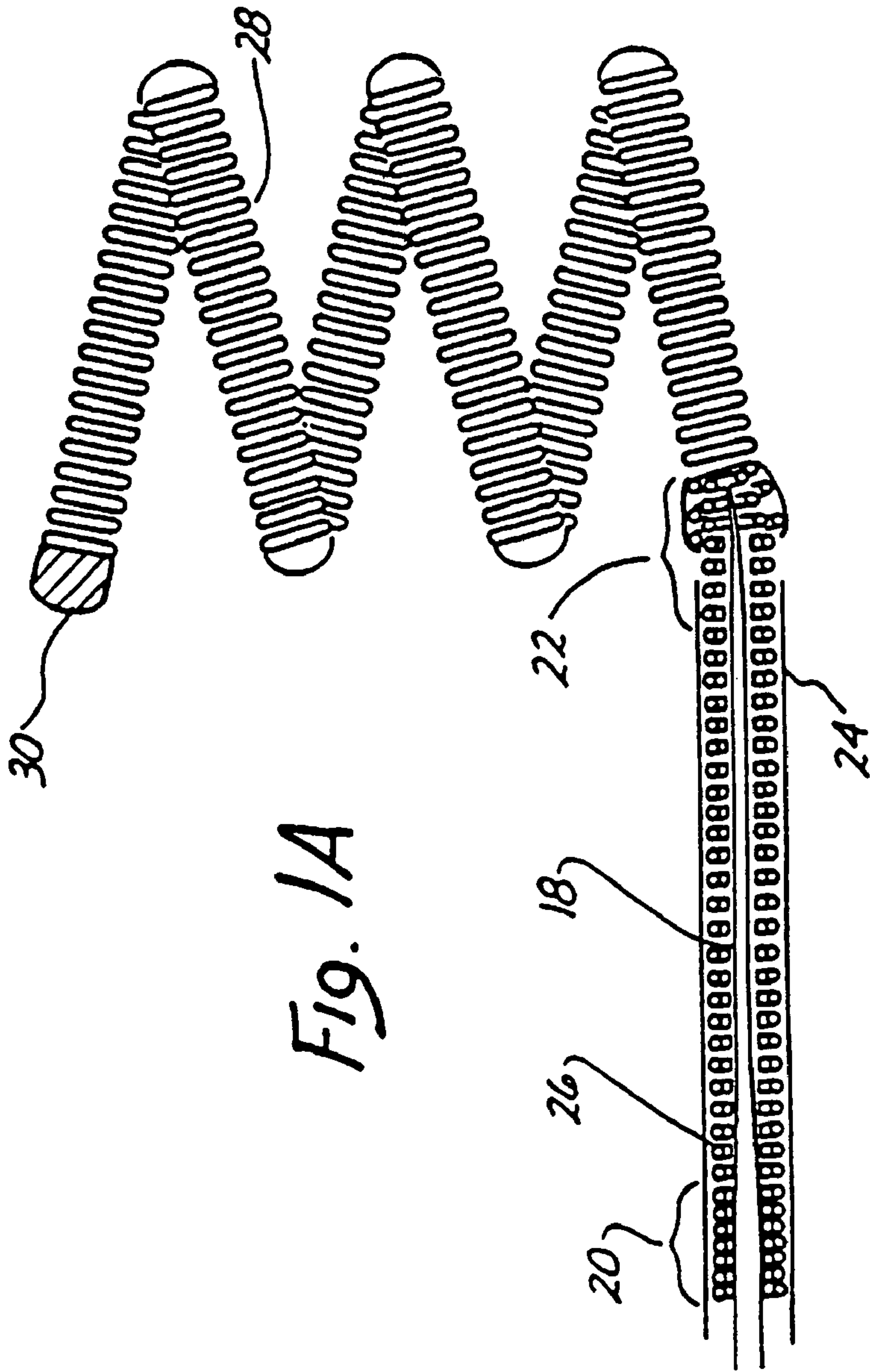

Fig. 1A

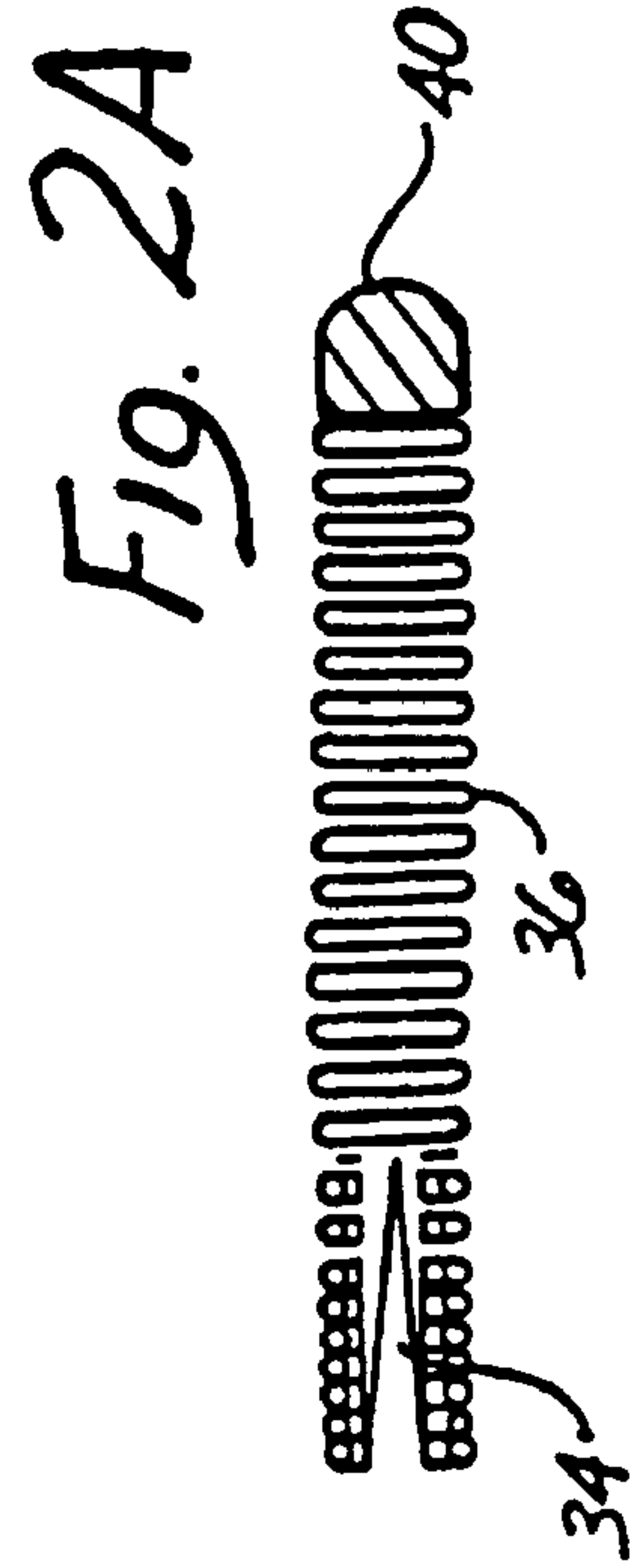

Fig. 2A

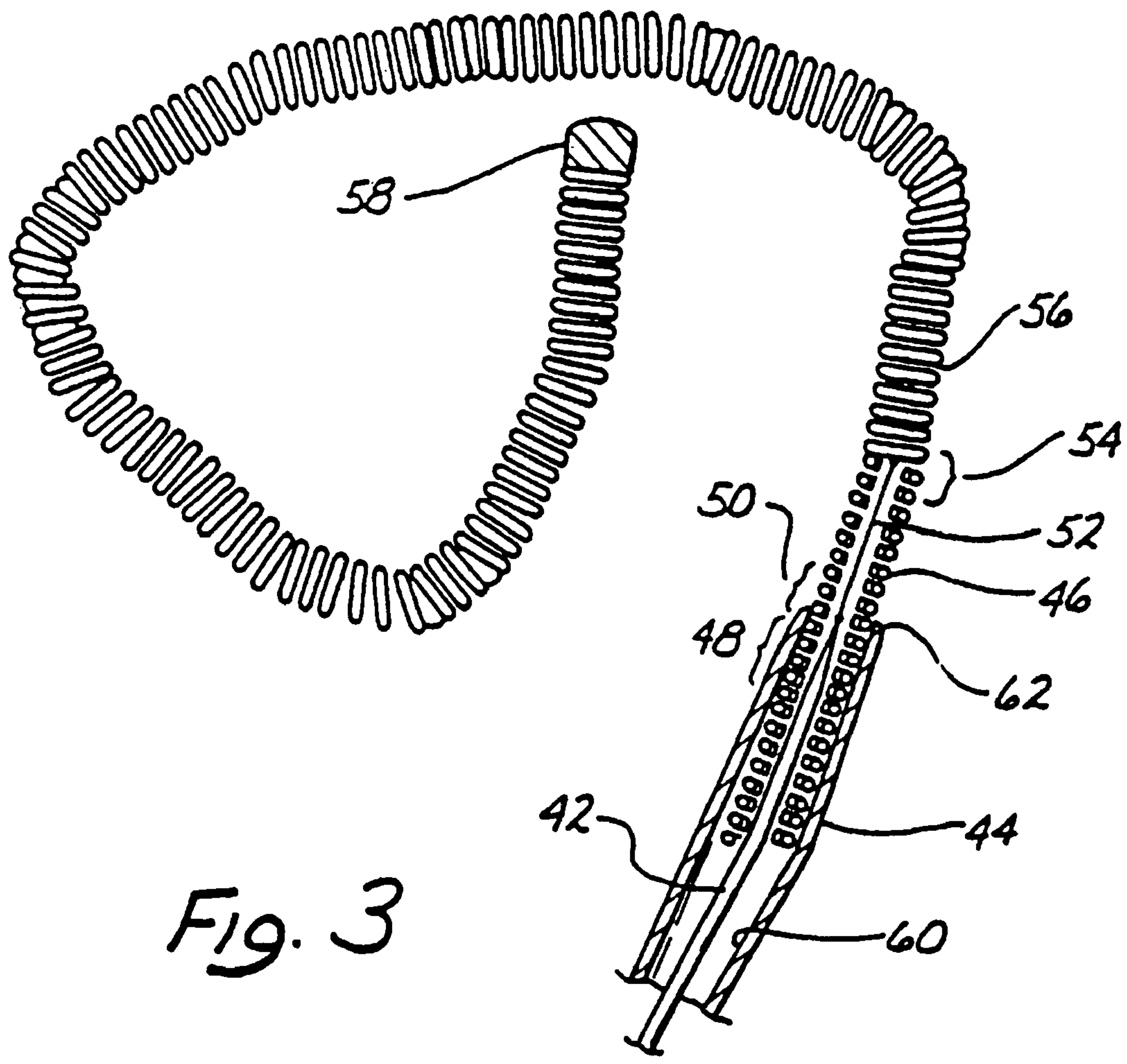
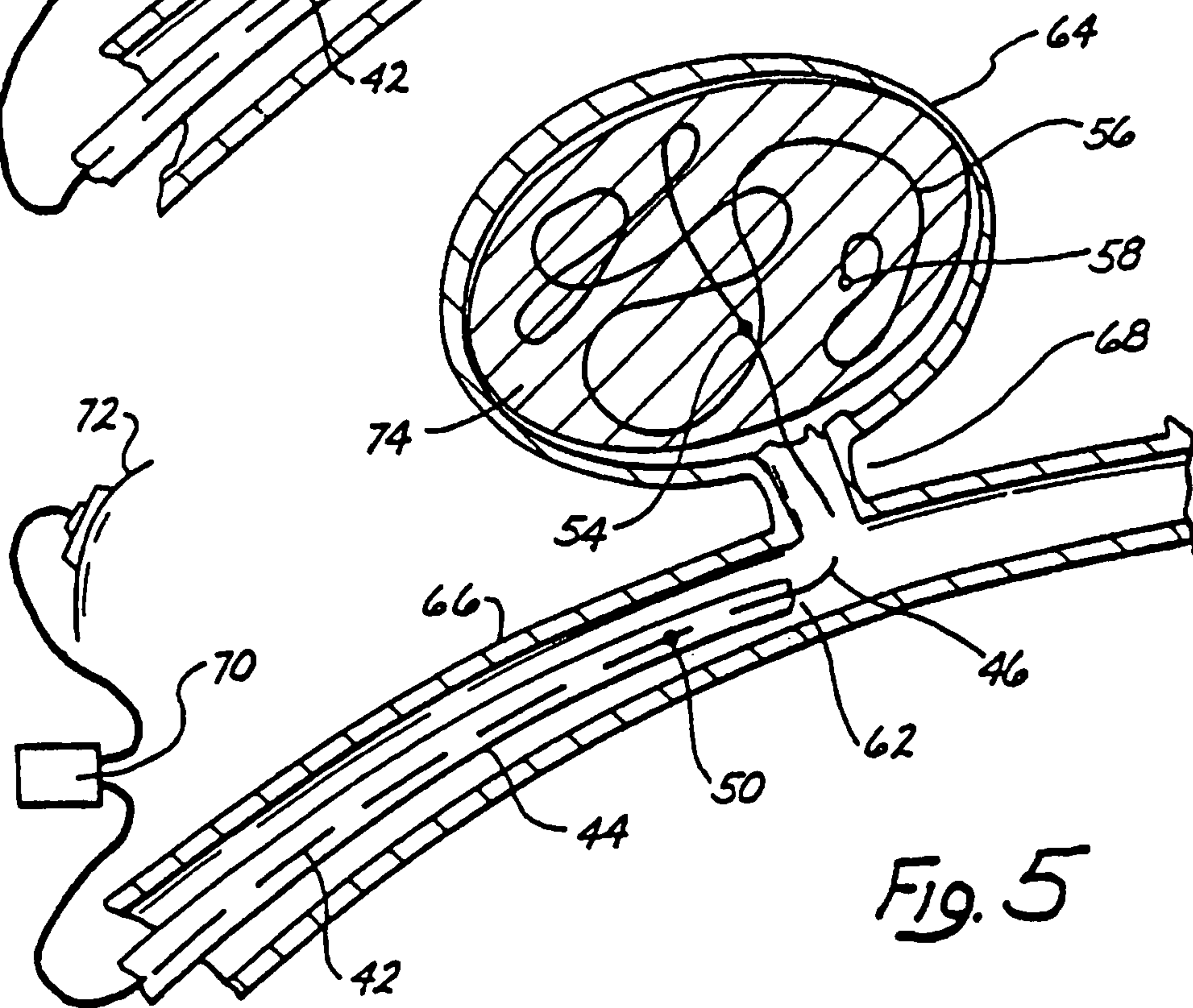
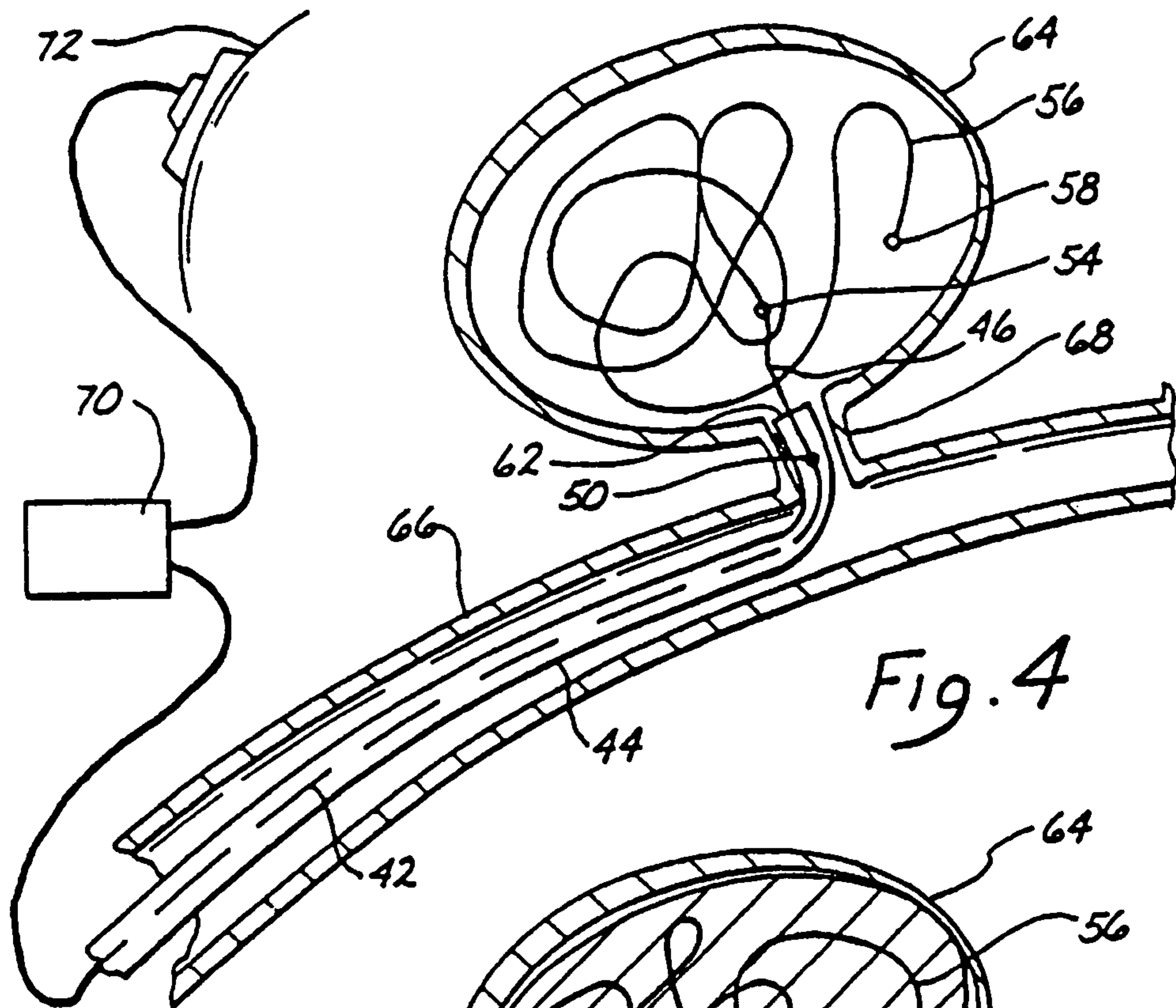

Fig. 3



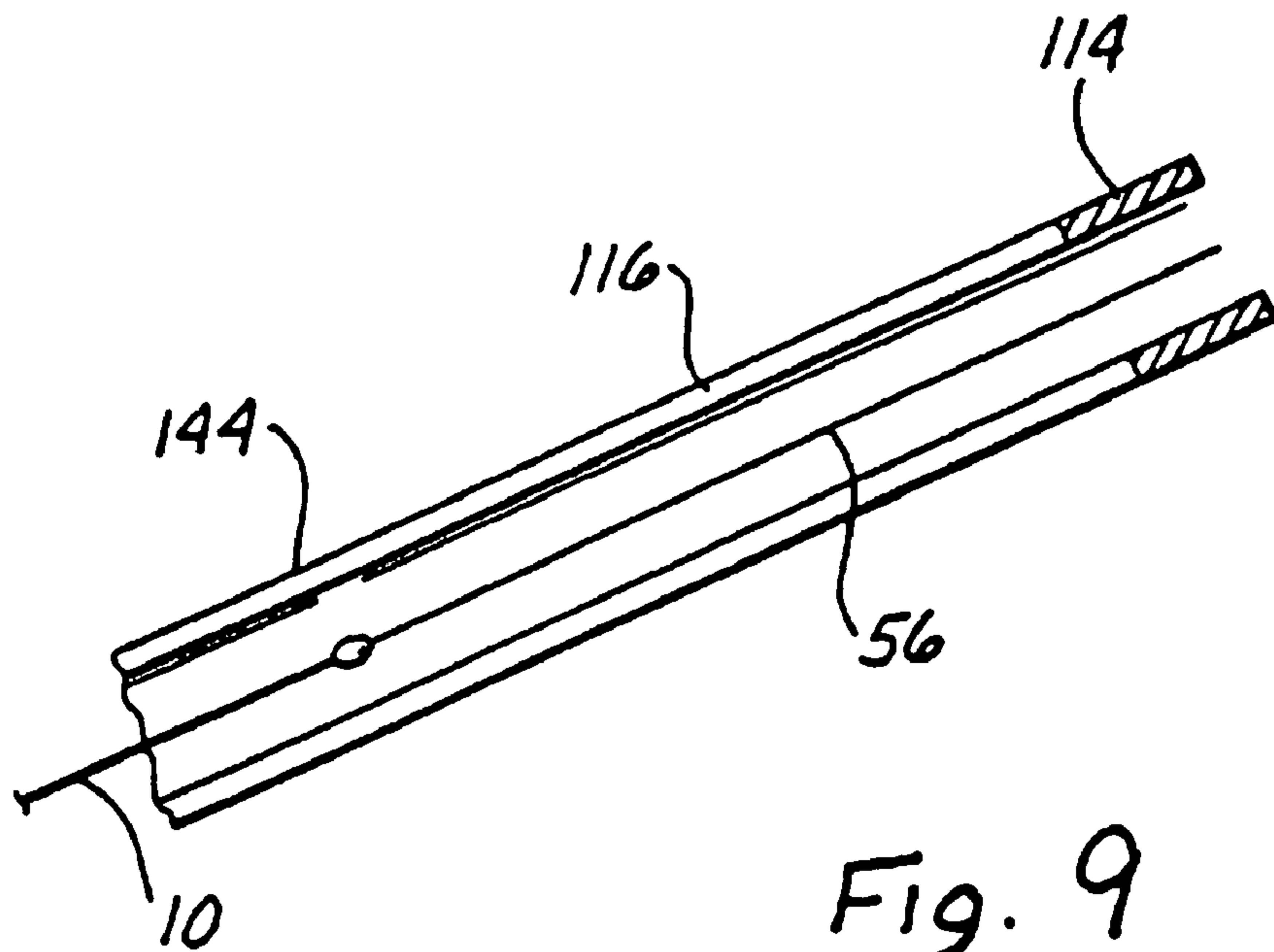
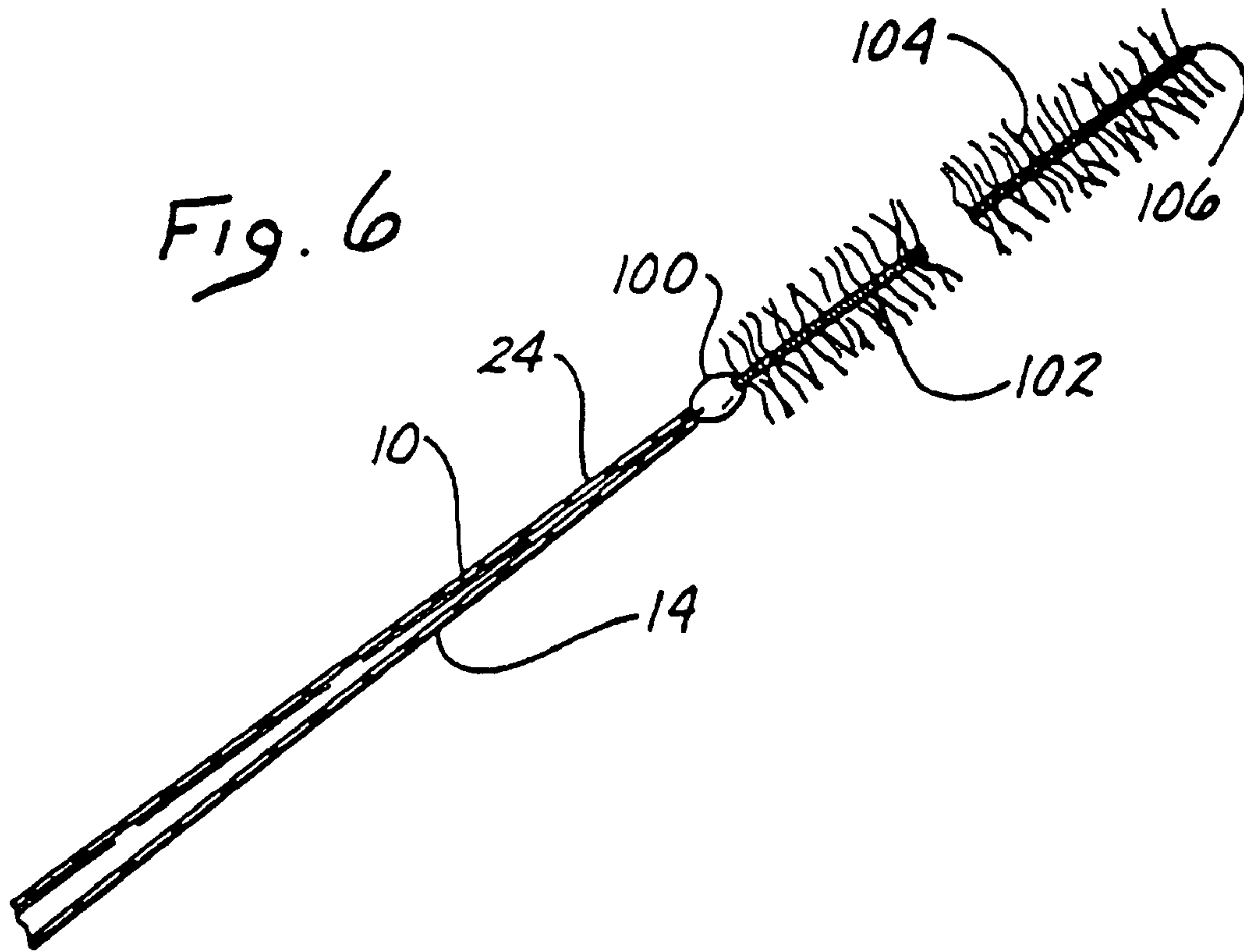
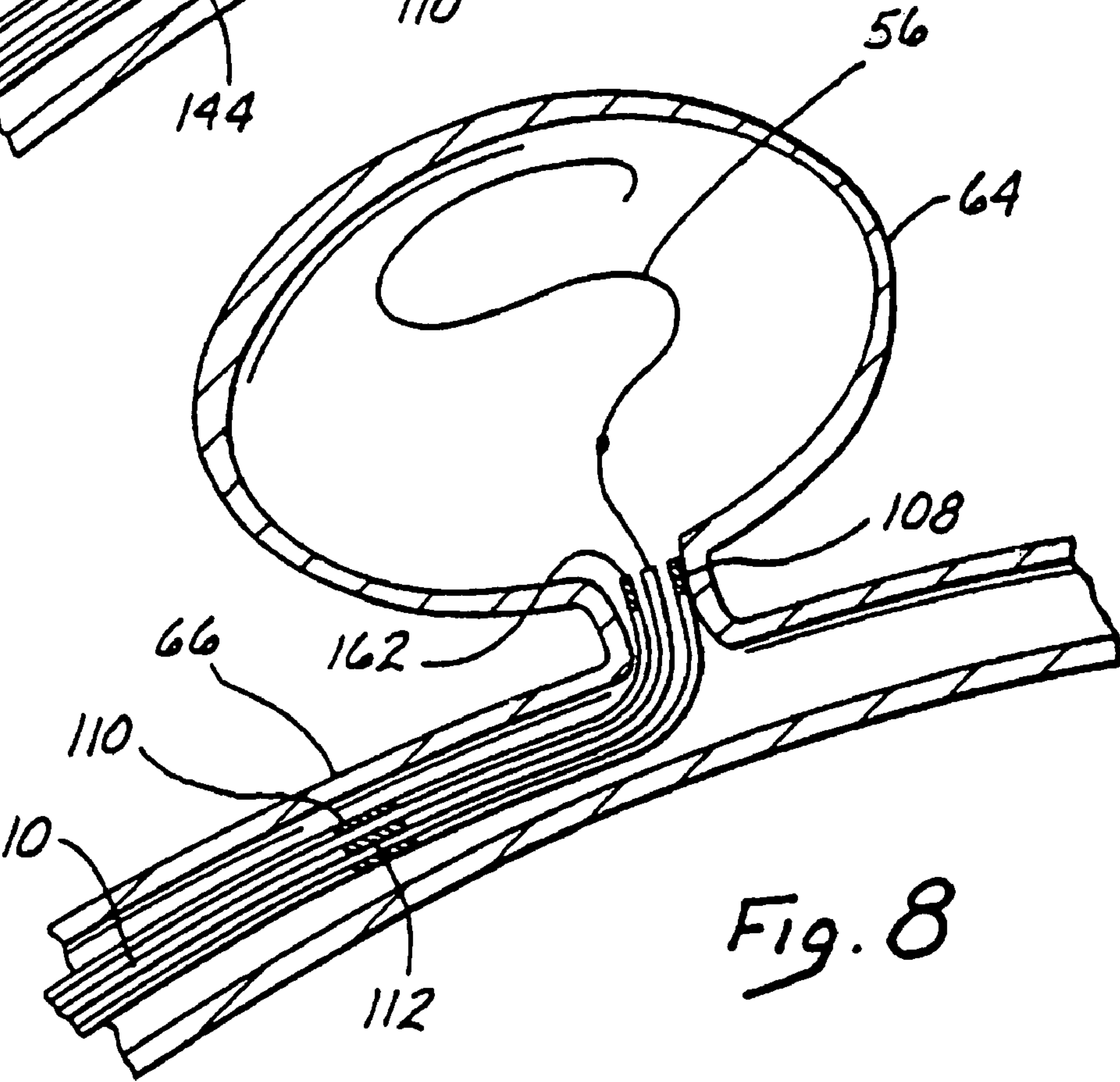
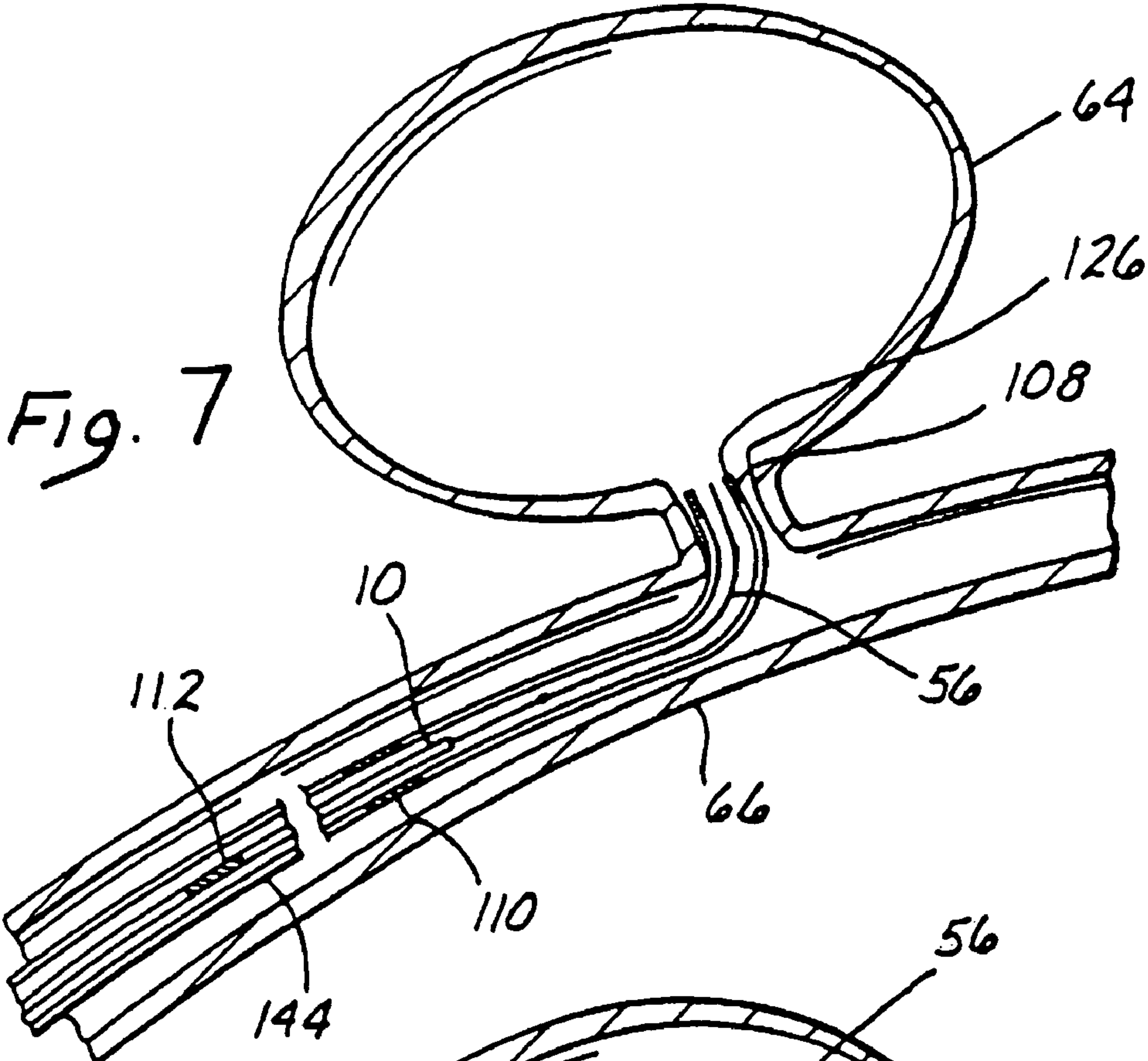

Fig. 9



**ENDOVASCULAR ELECTROLYTICALLY
DETACHABLE WIRE AND TIP FOR THE
FORMATION OF THROMBUS IN ARTERIES,
VEINS, ANEURYSMS, VASCULAR
MALFORMATIONS AND ARTERIOVENOUS
FISTULAS**

Matter enclosed in heavy brackets [] appears in the original patent but forms no part of this reissue specification; matter printed in italics indicates the additions made by reissue.

This application is a divisional of application Ser. No. 08/485,821 filed Jun. 6, 1995, now abandoned, *which is a divisional of application Ser. No. 08/311,508, filed on Sep. 23, 1994, issued as U.S. Pat. No. 5,540,680*, which in turn [was] is a continuation of application Ser. No. 07/840,211, filed on Feb. 24, 1992, now issued as U.S. Pat. No. 5,354,295, and which in its turn [was] is a continuation-in-part application of application Ser. No. 07/492,717, filed Mar. 13, 1990, issued as U.S. Pat. No. 5,122,136.

BACKGROUND OF THE INVENTION

1. Field of the Invention

The invention relates to a method and apparatus for endovascular electrothrombic formation of thrombi in arteries, veins, aneurysms, vascular malformations and arteriovenous fistulas.

2. Description of the Prior Art

Approximately 25,000 intracranial aneurysms rupture every year in North America. The primary purpose of treatment for ruptured intracranial aneurysm is to prevent rebleeding. At the present time, three general methods of treatment exist, namely an extravascular, endovascular and extra-endovascular approach.

The extravascular approach is comprised of surgery or microsurgery of the aneurysm or treatment site for the purpose of preserving the parent artery. This treatment is common with intracranial berry aneurysms. The methodology comprises the step of clipping the neck of the aneurysm, performing a sutureligation of the neck, or wrapping the entire aneurysm. Each of these surgical procedures is performed by intrusive invasion into the body and performed from outside the aneurysm or target site. General anesthesia, craniotomy, brain retraction and arachnoid dissection around the neck of the aneurysm and placement of a clip are typically required in these surgical procedures. Surgical treatment of vascular intracranial aneurysm can expect a mortality rate of 4-8% with a morbidity rate of 18-20%. Because of the mortality and morbidity rate expected, the surgical procedure is often delayed while waiting for the best surgical time with the result that an additional percentage of patients will die from the underlying disease or defect prior to surgery. For this reason the prior art has sought alternative means of treatment.

In the endovascular approach, the interior of the aneurysm is entered through the use of a microcatheter. Recently developed microcatheters, such as those shown by Engelson, "Catheter Guidewire", U.S. Pat. No. 4,884,579 and as described in Engelson, "Catheter for Guidewire Tracking", U.S. Pat. No. 4,739,768 (1988), allow navigation into the cerebral arteries and entry into a cranial aneurysm.

In such procedures a balloon is typically attached to the end of the microcatheter and it is possible to introduce the balloon into the aneurysm, inflate it, and detach it, leaving it to

occlude the sac and neck with preservation of the parent artery. While endovascular balloon embolization of berry aneurysms is an attractive method in situations where an extravascular surgical approach is difficult, inflation of a balloon into the aneurysm carries some risk of aneurysm rupture due to possible over-distention of portions of the sac and due to the traction produced while detaching the balloon.

While remedial procedures exist for treating a ruptured aneurysm during classical extravascular surgery, no satisfactory methodology exists if the aneurysm breaks during an endovascular balloon embolization.

Furthermore, an ideal embolizing agent should adapt itself to the irregular shape of the internal walls of the aneurysm. On the contrary, in a balloon embolization the aneurysmal wall must conform to the shape of the balloon. This may not lead to a satisfactory result and further increases the risk of rupture.

Still further, balloon embolization is not always possible. If the diameter of the deflated balloon is too great to enter the intracerebral arteries, especially in the cases where there is a vasospasm, complications with ruptured intracranial aneurysms may occur. The procedure then must be deferred until the spasm is resolved and this then incurs a risk of rebleeding.

In the extra-intravascular approach, an aneurysm is surgically exposed or stereotaxically reached with a probe. The wall of the aneurysm is then perforated from the outside and various techniques are used to occlude the interior in order to prevent it from rebleeding. These prior art techniques include electrothrombosis, isobutyl-cyanoacrylate embolization, hog-hair embolization and ferromagnetic thrombosis.

In the use of electrothrombosis for extra-intravascular treatment the tip of a positively charged electrode is inserted surgically into the interior of the aneurysm. An application of the positive charge attracts white blood cells, red blood cells, platelets and fibrinogen which are typically negatively charged at the normal pH of the blood. The thrombic mass is then formed in the aneurysm about the tip. Thereafter, the tip is removed. See Mullan, "Experiences with Surgical Thrombosis of Intracranial Berry Aneurysms and Carotid Cavernous Fistulas", J. Neurosurg., Vol. 41, December 1974; Hosobuchi, "Electrothrombosis Carotid-Cavernous Fistula", J. Neurosurg., Vol. 42, January 1975; Araki et al., "Electrically Induced Thrombosis for the Treatment of Intracranial Aneurysms and Angiomas", Excerpta Medica International Congress Series, Amsterdam 1965, Vol. 110, 651-654; Sawyer et al., "Bio-Electric Phenomena as an Etiological Factor in Intravascular Thrombosis", Am. J. Physiol., Vol. 175, 103-107 (1953); J. Piton et al., "Selective Vascular Thrombosis Induced by a Direct Electrical Current; Animal Experiments", J. Neuroradiology, Vol. 5, pages 139-152 (1978). However, each of these techniques involves some type of intrusive procedure to approach the aneurysm from the exterior of the body.

The prior art has also devised the use of a liquid adhesive, isobutylcyanoacrylate (IBCA) which polymerizes rapidly on contact with blood to form a firm mass. The liquid adhesive is injected into the aneurysm by puncturing the sac with a small needle. In order to avoid spillage into the parent artery during IBCA injection, blood flow through the parent artery must be momentarily reduced or interrupted. Alternatively, an inflated balloon may be placed in the artery at the level of the neck of the aneurysm for injection. In addition to the risks caused by temporary blockage of the parent artery, the risks of seepage of such a polymerizing adhesive into the parent artery exists, if it is not completely blocked with consequent occlusion of the artery.

Still further, the prior art has utilized an air gun to inject hog hair through the aneurysm wall to induce internal thrombosis. The success of this procedure involves exposing the aneurysm sufficiently to allow air gun injection and has not been convincingly shown as successful for thrombic formations.

Ferromagnetic thrombosis in the prior art in extraintravascular treatments comprises the stereotactic placement of a magnetic probe against the sac of the aneurysm followed by injection into the aneurysm by an injecting needle of iron microspheres. Aggregation of the microspheres through the extravascular magnet is followed by interneuysmatic thrombus. This treatment has not been entirely successful because of the risk of fragmentation of the metallic thrombus when the extravascular magnet is removed. Suspension of the iron powder in methyl methacrylate has been used to prevent fragmentation. The treatment has not been favored, because of the need to puncture the aneurysm, the risk of occlusion of the parent artery, the use of unusual and expensive equipment, the need for a craniectomy and general anesthesia, and the necessity to penetrate cerebral tissue to reach the aneurysm.

Endovascular coagulation of blood is also well known in the art and a device using laser optically generated heat is shown by O'Reilly, "Optical Fiber with Attachable Metallic Tip for Intravascular Laser Coagulation of Arteries, Veins, Aneurysms, Vascular Malformation and Arteriovenous Fistulas", U.S. Pat. No. 4,735,201 (1988). See also, O'Reilly et al., "Laser Induced Thermal Occlusion of Berry Aneurysms: Initial Experimental Results", *Radiology*, Vol. 171, No. 2, pages 471-74 (1989). O'Reilly places a tip into an aneurysm by means of an endovascular microcatheter. The tip is adhesively bonded to a optic fiber disposed through the microcatheter. Optical energy is transmitted along the optic fiber from a remote laser at the proximal end of the microcatheter. The optical energy heats the tip to cauterize the tissue surrounding the neck of the aneurysm or other vascular opening to be occluded. The catheter is provided with a balloon located on or adjacent to its distal end to cut off blood flow to the site to be cauterized and occluded. Normally, the blood flow would carry away the heat at the catheter tip, thereby preventing cauterization. The heat in the tip also serves to melt the adhesive used to secure the tip to the distal end of the optical fiber. If all goes well, the tip can be separated from the optical fiber and left in place in the neck of the aneurysm, provided that the cauterization is complete at the same time as the hot melt adhesive melts.

A thrombus is not formed from the heated tip. Instead, blood tissue surrounding the tip is coagulated. Coagulation is a denaturation of protein to form a connective-like tissue similar to that which occurs when the albumen of an egg is heated and coagulates from a clear running liquid to an opaque white solid. The tissue characteristics and composition of the coagulated tissue is therefore substantially distinct from the thrombosis which is formed by the thrombotic aggregation of white and red blood cells, platelets and fibrinogen. The coagulative tissue is substantially softer than a thrombic mass and can therefore more easily be dislodged.

O'Reilly's device depends at least in part upon the successful cauterization timed to occur no later than the detachment of the heat tip from the optic fiber. The heated tip must also be proportionally sized to the neck of the aneurysm in order to effectively coagulate the tissue surrounding it to form a blockage at the neck. It is believed that the tissue in the interior of the aneurysm remains substantially uncoagulated. In addition, the hot melt adhesive attaching the tip to the optic fiber melts and is dispersed into the adjacent blood tissue where it resolidifies to form free particles within the intrac-

ranial blood stream with much the same disadvantages which result from fragmentation of a ferromagnetic electrothrombosis.

Therefore, what is needed is an apparatus and methodology which avoids each of the shortcomings and limitations of the prior art discussed above.

BRIEF SUMMARY OF THE INVENTION

The invention is a method for forming an occlusion within a vascular cavity having blood disposed therein comprising the steps of endovascularly disposing a wire and/or tip near an endovascular opening into the vascular cavity. The wire may include a distinguishable structure at its distal end, which is termed a tip, in which case the remaining portion of the wire may be termed a guidewire. The term "wire" should be understood to collectively include both guidewires and tips and simply wires without distinct tip structures. However, the tip may also simply be the extension of the wire itself without substantial distinction in its nature. A distal tip of the wire is disposed into the vascular cavity to pack the cavity to mechanically form the occlusion within the vascular cavity about the distal tip. The distal tip is detached from the guidewire (or wire) to leave the distal tip within the vascular cavity. As a result, the vascular cavity is occluded by the distal tip, and by any thrombus formed by use of the tip.

In one embodiment, the step of detaching the distal tip from the guidewire (or wire) comprises the step of mechanically detaching the distal tip from the guidewire (or wire).

In another embodiment, the guidewire and tip (or wire) are used within a microcatheter and in the step of detaching the distal tip from the guidewire (or wire), the guidewire and tip (or wire) are longitudinally displaced within the microcatheter. The microcatheter has radio-opaque proximal and tip markers. The guidewire and tip (or wire) have collectively a single radio-opaque marker. The displacement of the guidewire and tip (or wire) moves the single radio-opaque marker to the proximity of the proximal marker on the microcatheter. At this point the tip will be fully deployed in the vascular cavity and tip separation may proceed. It is not necessary then in this embodiment to be able to see actual deployment of the tip before separation. The tip marker allows and enhances direct observation of the correct placement of the catheter tip into the opening of the vascular cavity.

In one embodiment the step of disposing the tip (or wire) into the vascular cavity to pack the cavity comprises the step of disposing a tip (or wire) having a plurality of filaments extending therefrom to pack the cavity.

In another embodiment the step of disposing the tip (or wire) into the vascular cavity to pack the cavity comprises the step of disposing a long flexible tip (or wire) folded upon itself a multiple number of times to pack the cavity.

The invention can also be characterized as a method for forming an occlusion within a vascular cavity having blood disposed therein comprising the steps of endovascularly disposing a wire within a microcatheter near an endovascular opening into the vascular cavity. The microcatheter has a distal tip electrode. The distal tip of the wire is disposed into the vascular cavity to pack the cavity to form the occlusion within the vascular cavity about the distal tip of the wire by applying a current between the distal tip electrode and the distal end of the wire packed into the cavity. The distal tip of the wire is detached from the wire to leave the distal tip of the wire within the vascular cavity. As a result, the vascular cavity is occluded by the distal tip, and by any thrombus formed by use of the tip.

5

The invention is also a wire for use in formation of an occlusion within a vascular cavity used in combination with a microcatheter comprising a core wire, and a detachable elongate tip portion extending the core wire for a predetermined lineal extent. The tip portion is adapted to be packed into the vascular cavity to form the occlusion in the vascular cavity and coupled to the distal portion of the core wire. As a result, endovascular occlusion of the vascular cavity can be performed.

In one embodiment, the elongate tip portion is a long and substantially pliable segment adapted to be multiply folded upon itself to substantially pack said vascular cavity.

In another embodiment, the elongate tip portion is a segment adapted to be disposed in said vascular cavity and having a plurality of filaments extending therefrom to substantially pack said vascular cavity when disposed therein.

In still another embodiment, the microcatheter has a pair of radioopaque markers disposed thereon and the core wire has a radioopaque marker disposed thereon. The marker on the core wire is positioned in the proximity of one of the pair of markers on the microcatheter when the core wire is fully deployed. The other marker on the core wire marks the position of the catheter tip.

The invention is still further characterized as a microcatheter system for use in formation of an occlusion within a vascular cavity comprising a microcatheter having a distal end adapted for disposition in the proximity of the vascular cavity. The distal end has an electrode disposed thereon. A conductive guidewire is disposed in the microcatheter and longitudinally displaceable therein. The guidewire comprises a core wire, and an elongate tip portion extending the core wire for a predetermined lineal extent. The tip portion is adapted to be packed into the vascular cavity to form the occlusion in the vascular cavity. The tip portion is coupled to the distal portion of the core wire. The occlusion is formed by means of applying a current between the tip portion and the electrode on the microcatheter when the tip portion is disposed into the vascular cavity. As a result, endovascular occlusion of the vascular cavity can be performed.

More generally speaking, the invention is a method for forming an occlusion within a vascular cavity having blood disposed therein comprising the steps of disposing a body into the cavity to substantially impede movement of blood in the cavity. The body is employed in the cavity to form the occlusion within the vascular cavity. As a result, the vascular cavity is occluded by the body.

The step of disposing the body in the vascular cavity comprises the step of packing the body to substantially obstruct the cavity.

In one embodiment the step of packing the cavity with the body comprises the step of obstructing the cavity with a detachable elongate wire tip multiply folded upon itself in the cavity.

The step of disposing the body into the vascular cavity comprises disposing in the vascular cavity means for slowing blood movement in the cavity to initiate formation of the occlusion in the cavity.

In another embodiment the step of packing the cavity with the body comprises the step of obstructing the cavity with a body having a compound filamentary shape.

The step of employing the body in the vascular cavity to form the occlusion comprises the step of applying an electrical current to the body or mechanically forming the occlusion in the body or both simultaneously.

The invention is also wire for use in formation of an occlusion within a vascular cavity used in combination with a microcatheter. The invention comprises a core wire and a

6

detachable elongate tip portion extending the core wire for a predetermined lineal extent. The core wire is adapted to being packed into the vascular cavity to form the occlusion in the vascular cavity and is coupled to the distal portion of the core wire. The tip portion includes a first segment for disposition into the cavity and a second segment for coupling the first portion to the core wire. The second segment is adapted to be electrolyzed upon application of current. An insulating coating is disposed on the first segment. The second segment is left exposed to permit selective electrolysis thereof. As a result, endovascular occlusion of the vascular cavity can be performed.

The invention can better be visualized by now turning to the following drawings wherein like elements are referenced by like numerals.

BRIEF DESCRIPTION OF THE DRAWINGS

FIGS. 1 and 1A are enlarged partially cross-sectioned side views of a first embodiment of the distal end of the guidewire and tip of the invention.

FIGS. 2 and 2A are enlarged longitudinal cross sections of a second embodiment of the guidewire and tip of the invention.

FIG. 3 is an enlarged side view of a third embodiment of the invention with a microcatheter portion cut away in a longitudinal cross-sectional view.

FIG. 4 is a simplified depiction of the wire of FIG. 3 shown disposed within a simple cranial aneurysm.

FIG. 5 is a depiction of the wire of FIG. 4 shown after electrolytic detachment of the tip.

FIG. 6 is a plan view of another embodiment of the guidewire and tip portion wherein the type is provided with a plurality of polyester filamentary hairs.

FIGS. 7 and 8 are a diagrammatic depictions of the use of the invention wherein position markers have been provided on the catheter and wire to assist in proper fluoroscopic manipulation.

FIG. 9 is a simplified cross-sectional view of the catheter and wire showing a ground electrode disposed on the distal tip of the catheter.

The invention and its various embodiments are best understood by now turning to the following detailed description.

DETAILED DESCRIPTION OF THE PREFERRED EMBODIMENTS

An artery, vein, aneurysm, vascular malformation or arterial fistula is occluded through endovascular occlusion by the endovascular insertion of a platinum tip into the vascular cavity. The vascular cavity is packed with the tip to obstruct blood flow or access of blood in the cavity such that the blood clots in the cavity and an occlusion is formed. The tip may be elongate and flexible so that it packs the cavity by being folded upon itself a multiple number of times, or may pack the cavity by virtue of a filamentary or fuzzy structure of the tip. The tip is then separated from the wire mechanically or by electrolytic separation of the tip from the wire. The wire and the microcatheter are thereafter removed leaving the tip embedded in the thrombus formed within the vascular cavity. Movement of wire in the microcatheter is more easily tracked by providing a radioopaque proximal marker on the microcatheter and a corresponding indicator marker on the wire. Electrothrombosis is facilitated by placing the ground electrode on the distal end of the microcatheter and flowing current between the microcatheter electrode and the tip.

When the tip is separated from the wire by electrolytic separation of the tip from the wire, a portion of the wire connected between the tip and the body of the wire is comprised of stainless steel and exposed to the bloodstream so that upon continued application of a positive current to the exposed portion, the exposed portion is corroded away at least at one location and the tip is separated from the body of the wire.

FIG. 1 is an enlarged side view of a first embodiment of the distal end of the wire and tip shown in partial cross-sectional view. A conventional Teflon laminated or similarly insulated stainless steel wire 10 is disposed within a protective microcatheter (not shown). Stainless steel wire 10 is approximately 0.010-0.020 inch (0.254-0.508 mm) in diameter. In the illustrated embodiment, wire 10 is tapered at its distal end to form a conical section 12 which joins a section 14 of reduced diameter which extends longitudinally along a length 16 of wire 10. Section 16 then narrows gradually down to a thin threadlike portion 18 beginning at a first bonding location 20 and ending at a second bonding location 22.

The stainless steel wire 10, comprised of that portion disposed within the microcatheter body, tapered section 12, reduced diameter section 16 and threadlike section 18, is collectively referred to as a core wire which typically is 50-300 cm. in length.

In the illustrated embodiment the portion of the core wire extending from tapered section 12 to second bonding location 22 is collectively referred to as the grinding length and may typically be between 20 and 50 cm. in length.

Reduced diameter portion 14 and at least part of sections 12 and first bonding location 20 may be covered with an insulating Teflon laminate 24 which encapsulates the underlying portion of wire 10 to prevent contact with the blood.

A stainless steel coil 26 is soldered to the proximate end of threadlike portion 18 of wire 10 at first bonding location 20. Stainless steel coil 26 is typically 3 to 10 cm. in length and like wire 10 has a diameter typically between 0.010 to 0.020 inch (0.254-0.508 mm).

The distal end of stainless steel coil 26 is soldered to the distal end of threadlike portion 18 of wire 10 and to the proximal end of a platinum secondary coil 28 at second bonding location 22. Secondary coil 28 itself forms a spiral or helix typically between 2 to 10 mm. in diameter. The helical envelope formed by secondary coil 28 may be cylindrical or conical. Like wire 10 and stainless steel coil 26, secondary coil 28 is between approximately 0.010 and 0.020 inch (0.254-0.508 mm) in diameter. The diameter of the wire itself forming stainless steel coil 26 and coil 28 is approximately between 0.001-0.005 inch.

The distal end of secondary coil 28 is provided with a platinum soldered tip 30 to form a rounded and smooth termination to avoid puncturing the aneurysm or tearing tissue.

Although prebiased to form a cylindrical or conical envelope, secondary coil 28 is extremely soft and its overall shape is easily deformed. When inserted within the microcatheter (not shown), secondary coil 28 is easily straightened to lie axially within the microcatheter. Once disposed out of the tip of the microcatheter, secondary coil 28 forms the shape shown in FIG. 1 and may similarly be loosely deformed to the interior shape of the aneurysm.

As will be described below in greater detail in connection with the third embodiment of FIG. 3, after placement of secondary coil 28 within the interior of the aneurysm a direct current is applied to wire 10 from a voltage source exterior to the body. The positive charge on secondary coil 28 within the cavity of the aneurysm causes a thrombus to form within the aneurysm by electrothrombosis. Detachment of the tip occurs

either: (1) by continued application of current for a predetermined time when the portion 18 is exposed to blood; or (2) by movement of the wire to expose portion 18 to blood followed by continued current application for a predetermined time. Ultimately, both threadlike portion and stainless steel coil 26 will be completely disintegrated at least at one point, thereby allowing wire 10 to be withdrawn from the vascular space while leaving secondary coil 28 embedded within the thrombus formed within the aneurysm.

FIG. 2 illustrates in enlarged partially cross-sectional view a second embodiment of the invention. Stainless steel core 32 terminates in a conical distal portion 34. Stainless steel coil 36, shown in cross-sectional view, is soldered to distal portion 34 of wire 32 at bonding location 38. The opposing end of the stainless steel coil 36 is provided with a soldered, rounded platinum tip 40. In the illustrated embodiment, stainless steel core wire 32 is approximately 0.010 inch in diameter with the length of stainless steel coil 36 being approximately 8 cm. with the longitudinal length of platinum tip 40 being between 3 and 10 mm. The total length of wire 32 from tip 40 to the proximate end is approximately 150 cm.

The embodiment of FIG. 2 is utilized in exactly the same manner as described above in connection with FIG. 1 to form a thrombic mass within an aneurysm or other vascular cavity. The embodiment of FIG. 2 is distinguished from that shown in FIG. 1 by the absence of the extension of stainless core 32 through coil 36 to tip 40. In the case of the embodiment of FIG. 2 no inner core or reinforcement is provided within stainless steel coil 36. Threadlike portion 18 is provided in the embodiment of FIG. 1 to allow increased tensile strength of the wire. However, a degree of flexibility of the wire is sacrificed by the inclusion even of threadlike tip 18, so that the embodiment of FIG. 2 provides a more flexible tip, at least for that portion of the micro-guidewire constituting the stainless steel coil 36.

It is expressly understood that the helical secondary coil tip of the embodiment of FIG. 1 could similarly be attached to stainless steel coil 36 of the embodiment of FIG. 2 without departing from the spirit and scope of the invention.

Thinned and threadlike portion guidewires disposed concentrically within coiled portions are well known and are shown in Antoshkiw, "Disposable Guidewire", U.S. Pat. No. 3,789,841 (1974); Sepetka et al., "Guidewire Device", U.S. Pat. No. 4,832,047 (1989); Engelson, "Catheter Guidewire", U.S. Pat. No. 4,884,579 (1989); Samson et al., "Guidewire for Catheters", U.S. Pat. No. 4,538,622 (1985); and Samson et al., "Catheter Guidewire with Short Spring Tip and Method of Using the Same", U.S. Pat. No. 4,554,929 (1985).

Turn now to the third embodiment of the invention as shown in FIG. 3. FIG. 3 shows an enlarged side view of a wire, generally denoted by reference numeral 42, disposed within a microcatheter 44 shown in cross-sectional view. Like the embodiment of FIG. 1, a stainless steel coil 46 is soldered to a conical portion 48 of wire 22 at a first bonding location 50. A thin threadlike extension 52 is then longitudinally disposed within stainless steel coil 46 to a second bonding location 54 where stainless steel wire 46 and threadlike portion 52 are soldered to a soft platinum coil 56. Platinum coil 56 is not prebiased, nor does it contain any internal reinforcement, but is a free and open coil similar in that respect to stainless steel coil 36 of the embodiment of FIG. 2.

However, platinum coil 56 is particularly distinguished by its length of approximately 1 to 50 cm. and by its flexibility. The platinum or platinum alloy used is particularly pliable and the diameter of the wire used to form platinum coil 56 is approximately 0.001-0.005 inch in diameter. The distal end of

platinum coil **56** is provided with a smooth and rounded platinum tip **58** similar in that respect to tips **30** and **40** of FIGS. **1** and **2**, respectively.

When coil **56** is disposed within microcatheter **44**, it lies along the longitudinal lumen **60** defined by microcatheter **44**. The distal end **62** of microcatheter **60** is then placed into the neck of the aneurysm and the wire **42** is advanced, thereby feeding tip **58** in platinum coil **56** into aneurysm **64** until bonding location **50** resides in the neck of the aneurysm as best depicted in the diagrammatic cross-sectional view of FIG. **4**.

FIG. **4** illustrates the insertion of the embodiment of FIG. **3** within a vessel **66** with distal tip of microcatheter **44** positioned near neck **68** of aneurysm **64**. Coil **56** is fed into aneurysm **64** until at least a portion of stainless steel coil **46** is exposed beyond the distal tip **62** of microcatheter **44**. A positive electric current of approximately 0.01 to 2 milliamps at 0.1-6 volts is applied to wire **42** to form the thrombus. Typically a thrombus will form within three to five minutes. The negative pole **72** of voltage source **70** is typically placed over and in contact with the skin.

After the thrombus has been formed and the aneurysm completely occluded, tip **58** and coil **56** are detached from wire **42** by electrolytic disintegration of at least one portion of stainless steel coil **46**. In the illustrated embodiment this is accomplished by continued application of current until the total time of current application is almost approximately four minutes.

At least one portion of stainless steel coil **46** will be completely dissolved through by electrolytic action within 3 to 10 minutes, usually about 4 minutes. After separation by electrolytic disintegration, wire **42**, microcatheter **44** and the remaining portion of coil **46** still attached to wire **42** are removed from vessel **66**, leaving aneurysm **64** completely occluded as diagrammatically depicted in FIG. **5** by thrombus **74**. It will be appreciated that the time of disintegration may be varied by altering the dimensions of the portions of the wire and/or the current.

The process is practiced under fluoroscopic control with local anesthesia at the groin. A transfemoral microcatheter is utilized to treat the cerebral aneurysm. The platinum is not affected by electrolysis and the remaining portions of the microcatheter are insulated either by a Teflon lamination directly on wire **42** and/or by microcatheter **44**. Only the exposed portion of the wire **46** is affected by the electrolysis.

It has further been discovered that thrombus **74** continues to form even after detachment from wire **42**. It is believed that a positive charge is retained on or near coil **56** which therefore continues to attract platelets, white blood cells, red blood cells and fibrinogen within aneurysm **64**.

Although the foregoing embodiment has been described as forming an occlusion within a blood-filled vascular cavity by means of electrothrombosis, the above disclosure must be read to expressly include formation of the occlusion by mechanical mechanisms without resort to the application of electrical current. A mechanical mechanism which can be safely disposed into the vascular cavity to impede, slow or otherwise initiate clotting of the blood or formation of the occlusion is within the scope of the invention. The insertion within the vascular cavity and maintenance therein of an object with an appropriate blood-clotting characteristics can and does in many cases cause the formation of an occlusion by itself. Depicted in FIG. **6** is an embodiment of the invention wherein such mechanical thrombosis can be achieved. Wire **10** has a tapering end portion **14** covered with a Teflon laminate **24** similar to that described in connection with the embodiment of FIG. **1**. Wire **10** is attached by means of a

mechanical coupling **100** to a platinum coil **102** which has a plurality of filaments or fine hairs **104** extending therefrom. In the illustrated embodiment, hairs **104** have a length as may be determined from the size of the vascular cavity in which coil **102** is to be used. For example, in a small vessel hair lengths of up to 1 mm are contemplated. An example of polyester filaments or hairs attached to a coil which was not used in electrothrombosis may be seen in the copending application entitled Vasoocclusion Coil with Attached Fibrous Elements, filed Oct. 2, 1991, Ser. No. 07/771,013.

Coil **102** has sufficient length and flexibility that it can be inserted or coiled loosely into the vascular cavity. The length of coil **102** need not be so long that the coil itself is capable of being multiply folded on itself and fill or substantially fill the vascular cavity. Hairs **104** extending from coil **102** serve to substantially pack, fill or at least impede blood flow or access in the vascular cavity. Hairs **104**, which are generally inclined backwardly away from extreme tip **106** when delivered, are thus easily able to slide forward with little friction through restrictions in the vessels and aneurysm. Additionally, hairs **104** do not have sufficient length, strength or sharpness to provide any substantial risk or potential for a puncture of the thin vascular wall. The plurality of hairs **104**, when coiled within the vascular cavity, provide an extremely large surface for attachment of blood constituents to encourage and enhance the formation of a mechanical occlusion within the vascular opening.

In the preferred embodiment, coil **102** is mechanically coupled to thin tapered portion **104** of wire **10** by means of a small drop of polyester **100**. Polyester may be substituted for the gold solder of the previously described embodiments in order to reduce concern or risk of toxic reactions in the body.

Tip portion **104** may also be mechanically separated from wire **10** by means other than electrolysis. One method is make the connection between tip **104** and wire **10** by means of a spring loaded mechanical clasp (not shown). The clasps are retained on tip **104** as long as the clasps remain inside of the catheter, but spring open and release tip **104** when extended from the catheter. The catheter and clasps may then be removed from the insertion site. This type of mechanical connection is described in the copending application entitled, "Detachable Pusher-Vasoocclusive Coil Assembly with Interlocking Coupling", filed Dec. 12, 1991 with Ser. No. 07/806,979 which is incorporated herein by reference and assigned to Target Therapeutics Inc. An alternative nonresilient mechanical ball and clasp capturing mechanism is described in the copending application entitled "Detachable Pusher-Vasoocclusive Coil Assembly with Interlocking Ball and Keyway Coupling", filed Dec. 12, 1991 with Ser. No. 07/806,912 which is also incorporated herein by reference and assigned to Target Therapeutics Inc.

In another embodiment wire **10** and tip portion **104** screw into each other and can be unscrewed from each other by rotation of the catheter or wire with respect to tip **104**. An extendable sheath (not shown) in the microcatheter is advanced to seize tip **104** to prevent its rotation with wire **10** during the unscrewing process. This type of mechanical connection is described in the copending application entitled "Detachable Pusher-Vasoocclusive Coil Assembly with Threaded Coupling", filed Dec. 12, 1991 with Ser. No. 07/806,898 which is incorporated herein by reference and assigned to Target Therapeutics Inc.

In any case the specific means disclosed here of mechanically detaching tip **104** from wire **10** forms no part of the present invention apart from its combination as a whole with other elements of the invention. Specific disclosure of the mechanical means of detachment have been set forth only for

the purposes of providing an enabling disclosure of the best mode presently known for practicing the claimed invention.

Even where the occlusion is not formed by electrothrombosis, separation of tip **104** may be effected by electrolysis. In such situations, the electrolysing current may be concentrated on the sacrificial stainless steel portion of tip **104** by disposition of an insulative coating on the remaining platinum portion. For example, tip **104** may be provided with a polyethylene coating save at least a portion of the stainless steel length. This has the effect of decreasing the time required to electrolytically sufficiently disintegrate the steel portion to allow detachment of the platinum tip, which is an advantageous feature in those cases where a large aneurysm must be treated and a multiple number of coils must be deployed within the aneurysm.

Notwithstanding the fact that wire **10** and platinum coil **102** in the embodiment FIG. **6** or wire **10** and platinum coil **28, 36** and **56** in the embodiments of FIGS. **1-5** are radiopaque, there is still some difficulty when manipulating the device under fluoroscopy to be able to determine the exact position or movement of the probe relative to the aneurysm. This is particularly true when a large number of coils are deployed and one coil then radiographically hides another. FIG. **7** illustrates an improvement of, for example, the embodiment of FIGS. **4** and **5**. Microcatheter **144** is positioned so that its distal end **162** within vessel **66** is positioned at the opening aneurysm **64**. Microcatheter **144** is provided with radiopaque marker **108** at distal tip **162**, a tip marker. Moving toward the proximal end of microcatheter **144** is a second radiopaque marker **110**, a proximal marker. Radiopaque markers **108** and **110** are, for example, in the form of radiopaque rings made of platinum, approximately 1-3 mm in longitudinal length along the axis of microcatheter **144**. Rings **110** and **108** are typically separated by about 3 cm on microcatheter **144**. Similarly, wire **10** has a radiopaque marker **112** defined on it such that marker **112** on wire **10** is approximately with aligned with marker **110** on microcatheter **14** when coil **56** is fully deployed into aneurysm **64**. Typically, full deployment will place the solder or connection point **54** of the order of 2-3 mm past opening **68** of aneurysm **64**. Distal marker **108** on microcatheter **144** is used to facilitate the location of the microcatheter tip, which can often be obscured by the coils which have been previously deployed. The coils are a varying lengths depending on the application or size of the aneurysm or vascular cavity being treated. Coil lengths of 4-40 cm are common. Therefore, even though the thinness of coil **56** may make it difficult to see under standard fluoroscopy and even though the fineness of wire **10** may similarly be obscured or partly obscured, radiopaque markers **108, 110** and **112** are clearly visible. Manipulation of wire **10** to proximal marker **110** can then easily be observed under conventional fluoroscopy even when there are some loss of resolution or fluoroscopic visual obstruction of the coil.

Further, in the previous embodiments, such as that shown in FIGS. **4** and **5**, when electrothrombosis is used to form the occlusion within vascular aneurysm **64**, coil **56** is used as the electrical anode while the cathode is a large skin electrode **72** typically conductively applied to the groin or scalp. FIG. **9** illustrates an alternative embodiment wherein microcatheter **144** is supplied with an end electrode **114** coupled to an electrical conductor **116** disposed along the length of microcatheter **144**. Wire **116** is ultimately led back to voltage source **70** so that ring electrode **114** is used as the cathode during

electrothrombosis instead of an exterior skin electrode **72**. With the embodiment of FIG. **9**, the electrical currents and electrical current paths which are set up during the electrothrombosis formation are local to the site of application which allows even smaller currents and voltages to be used to initiate electrothrombosis than in the situation when an exterior skin electrode must be utilized. The electrothrombotic current distributions are also better controlled and localized to the site of the thrombus formation. The possibility of stray thrombus formations occurring at unwanted sites or uncontrolled and possibly unwanted electrical current patterns being established elsewhere in the brain or body is therefore largely avoided.

Many alterations and modifications may be made by those having ordinary skill in the art without departing from the spirit and scope of the invention. Therefore, it must be understood that the shape of the tip or distal platinum coil used in combination with the wire according to the invention may be provided with a variety of shapes and envelopes. In addition thereto, the composition of the micro-guidewire tip may be made of elements other than platinum including stainless steel, beryllium, copper and various alloys of the same with or without platinum. Still further, the diameter of the wire, various of the wire described above and the stainless steel coil immediately proximal to the detachable tip may be provided with differing diameters or cross sections to vary the times and current magnitudes necessary in order to effectuate electrolytic detachment from the tip. Still further, the invention may include conventional electronics connected to the proximal end of the wire for determining the exact instant of detachment of the distal tip from the wire.

Therefore, the illustrated embodiment has been set forth only for the purposes of clarity and example and should not be taken as limiting the invention as defined by the following claims, which include all equivalent means whether now known or later devised.

We claim:

1. A wire for use in the formation of an occlusion within a vascular cavity in conjunction with a microcatheter having an interior lumen, said wire comprising:

a metal coil having a first shape which conforms to said microcatheter lumen when within the microcatheter, and said metal coil forming an unbiased, regular cylindrical or unbiased single regular conical envelope when disposed out of said microcatheter.

2. The wire of claim 1 wherein the wire comprises platinum.

3. The wire of claim 1 wherein the diameter of the coil is approximately 0.001-0.005 inch.

4. The wire of claim 1 wherein the diameter of the coil is approximately 0.010-0.020 inch.

5. The wire of claim 1 wherein the diameter of the envelope is approximately 2-10 mm.

6. The wire of claim 1 wherein the envelope is conical.

7. The wire of claim 1 wherein the envelope is cylindrical.

8. The wire of claim 1 further comprising a plurality of filaments extending from said first shape.

9. The wire of claim 8 wherein the filaments comprise polyester.

10. The wire of claim 2 wherein the coil is prebiased to form said cylindrical or conical envelope.

* * * * *