

US00RE42622E

(19) **United States**  
(12) **Reissued Patent**  
**Kurotaki**

(10) **Patent Number:** **US RE42,622 E**  
(45) **Date of Reissued Patent:** **Aug. 16, 2011**

(54) **DIGITAL BROADCAST RECORDING APPARATUS**

2005/0047596 A1 3/2005 Suzuki  
2005/0100321 A1 5/2005 Koudo et al.  
2006/0078296 A1 4/2006 Takao

(75) Inventor: **Mitsuru Kurotaki**, Lawrenceville, NJ (US)

**FOREIGN PATENT DOCUMENTS**

EP 0338866 10/1989  
EP 0543668 5/1993  
JP 10-215444 8/1998

(73) Assignee: **Panasonic Corporation**, Osaka (JP)

(21) Appl. No.: **12/907,479**

**OTHER PUBLICATIONS**

(22) Filed: **Oct. 19, 2010**

U.S. Appl. No. 11/285,165 to Takao, filed Nov. 23, 2005.

English language Abstract of JP 10-215444.

English language Abstract of JP 10-215444 dated Nov. 8, 1998.

**Related U.S. Patent Documents**

Reissue of:

(64) Patent No.: **7,558,470**  
Issued: **Jul. 7, 2009**  
Appl. No.: **11/295,651**  
Filed: **Dec. 7, 2005**

\* cited by examiner

*Primary Examiner* — Robert Chevalier

(74) *Attorney, Agent, or Firm* — Greenblum & Bernstein, P.L.C.

(30) **Foreign Application Priority Data**

Dec. 8, 2004 (JP) ..... 2004-355430

(57) **ABSTRACT**

(51) **Int. Cl.**  
*H04N 5/84* (2006.01)  
*H04N 5/92* (2006.01)  
*H04N 5/928* (2006.01)

(52) **U.S. Cl.** ..... **386/334; 386/326; 386/338**

(58) **Field of Classification Search** ..... **386/334, 386/326, 338, 328, 330**  
See application file for complete search history.

The present invention provides a digital broadcast recording apparatus which prevents an unnecessary recording in a situation where it is not possible to descramble a program or it is prohibited to record a scrambled program. The digital broadcast recording apparatus includes a descrambler that detects a channel where a descrambling-not-possible situation occurs. The apparatus also includes a service manager which terminates the recording and writes, into a management table, that a descrambling-not-possible situation has occurred during recording, when there is recording data showing that recording is being executed on the channel which is detected as having the descrambling-not-possible situation.

(56) **References Cited**

**U.S. PATENT DOCUMENTS**

5,111,444 A 5/1992 Fukushima et al.  
5,406,625 A 4/1995 Kotaka et al.  
5,799,081 A \* 8/1998 Kim et al. .... 380/203

**2 Claims, 37 Drawing Sheets**

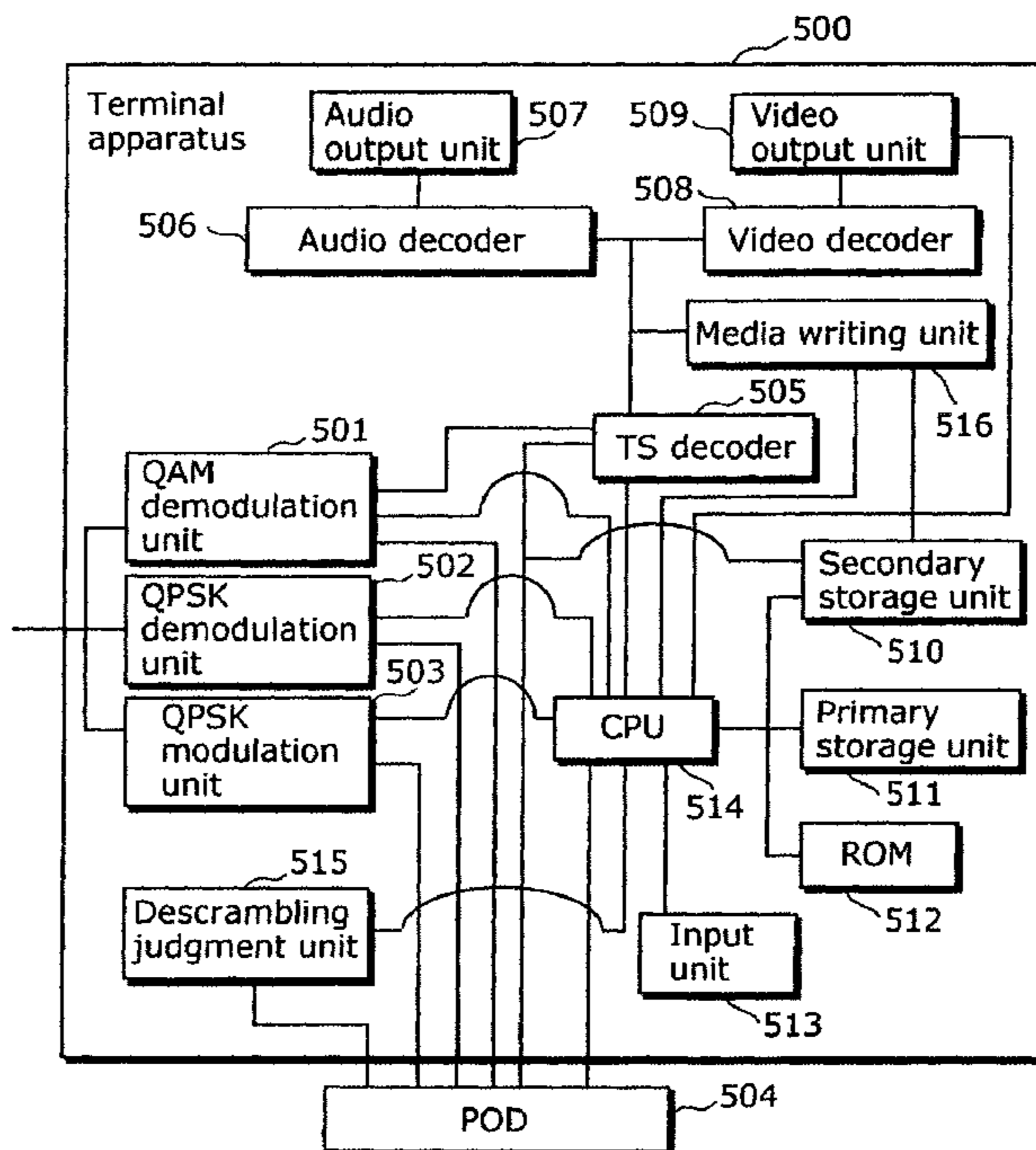

FIG. 1

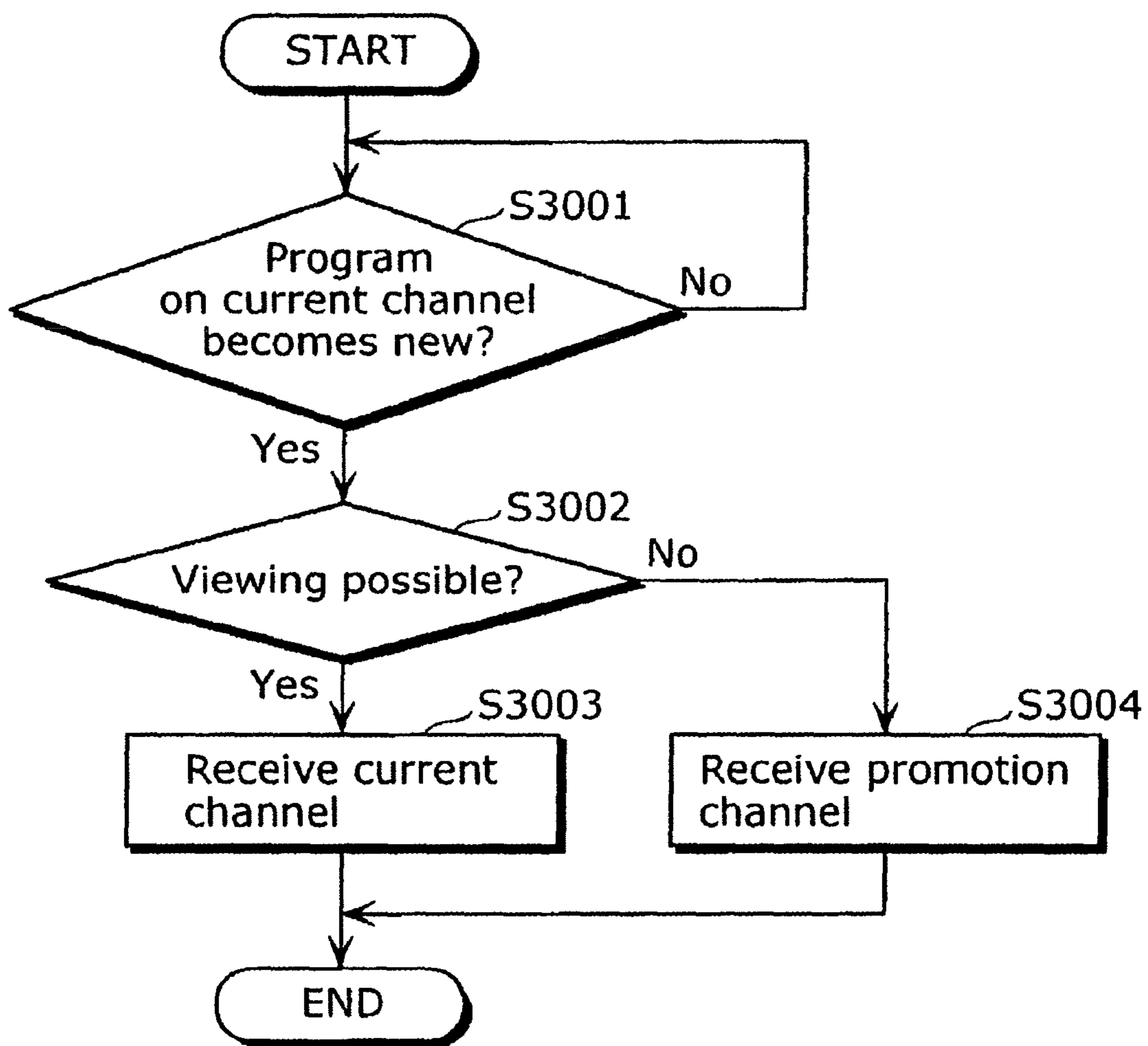

FIG. 2

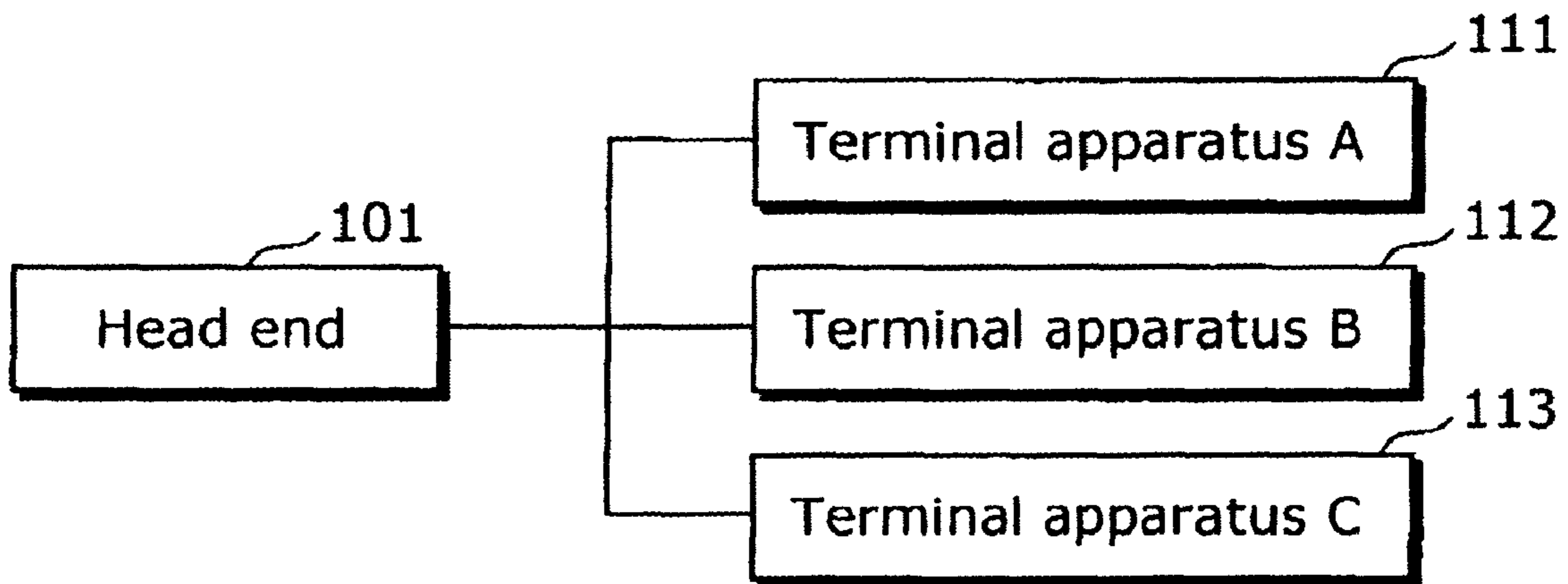

FIG. 3

Frequency band	Usage	Modulation technique
5~130MHz	Out Of Band (OOB) Data exchange between head end and terminals	QPSK
130~864MHz	In-band Ordinary television broadcasting including video and audio	QAM

FIG. 4

Frequency band	Usage
70~74MHz	Data transmission from head end 101 to terminal apparatuses
10.0~10.1MHz	Data transmission from terminal apparatus A111 to head end 101
10.1~10.2MHz	Data transmission from terminal apparatus B112 to head end 101
10.2~10.3MHz	Data transmission from terminal apparatus C113 to head end 101

FIG. 5

Frequency band	Usage
150~156MHz	Television channel 1
156~162MHz	Television channel 2
⋮	⋮
310~311MHz	Radio channel 1
⋮	⋮

FIG. 6

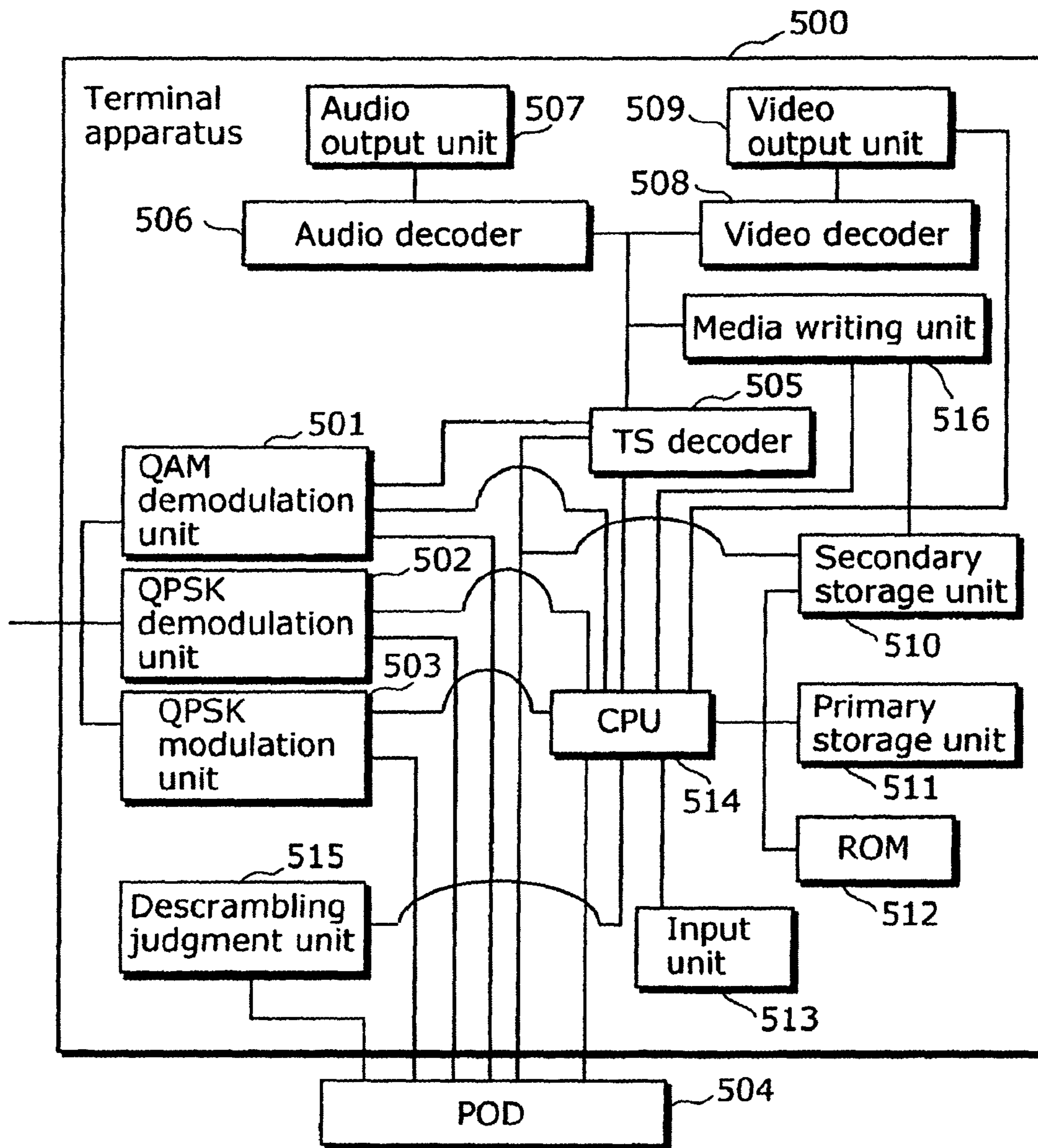

FIG. 7

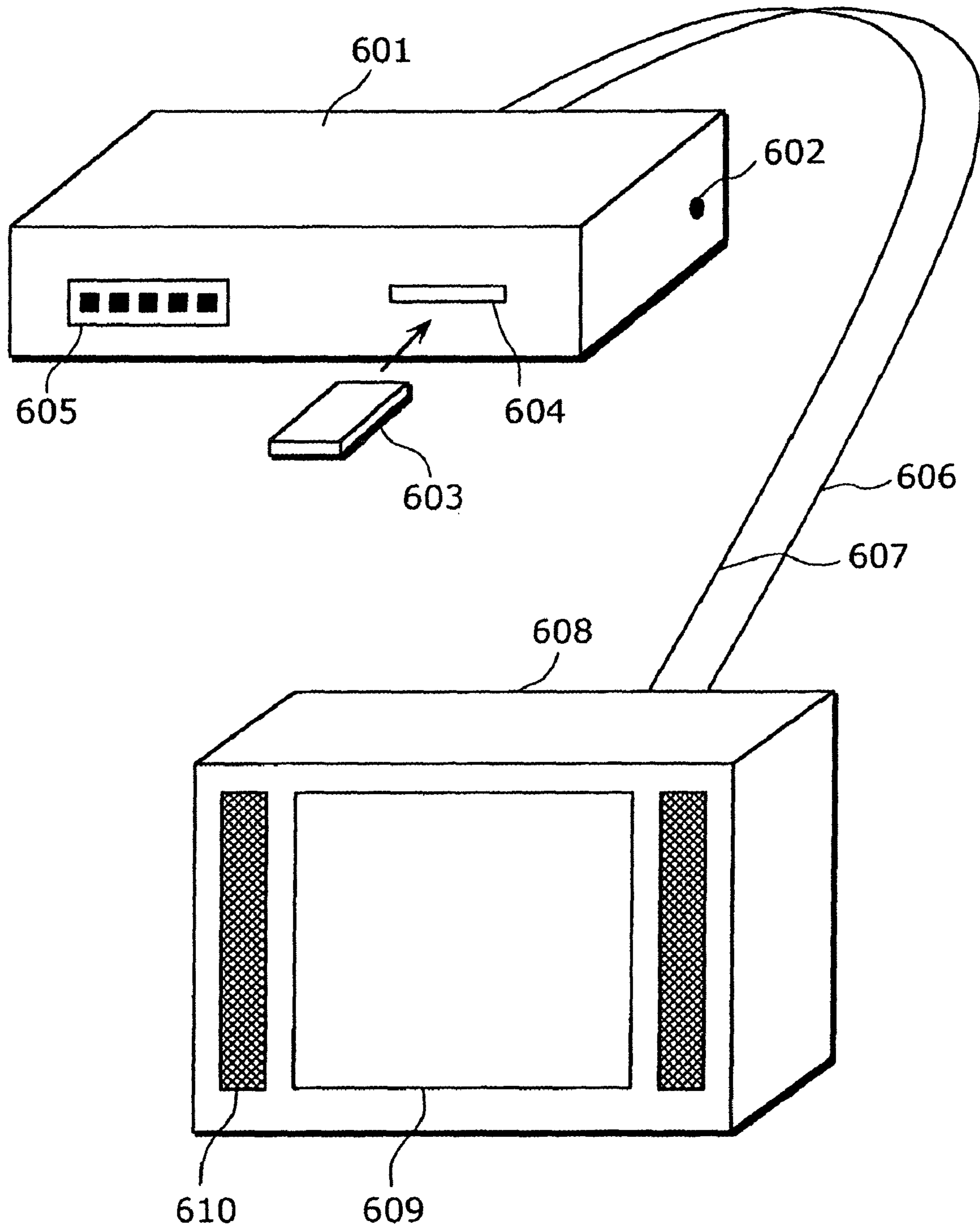

FIG. 8

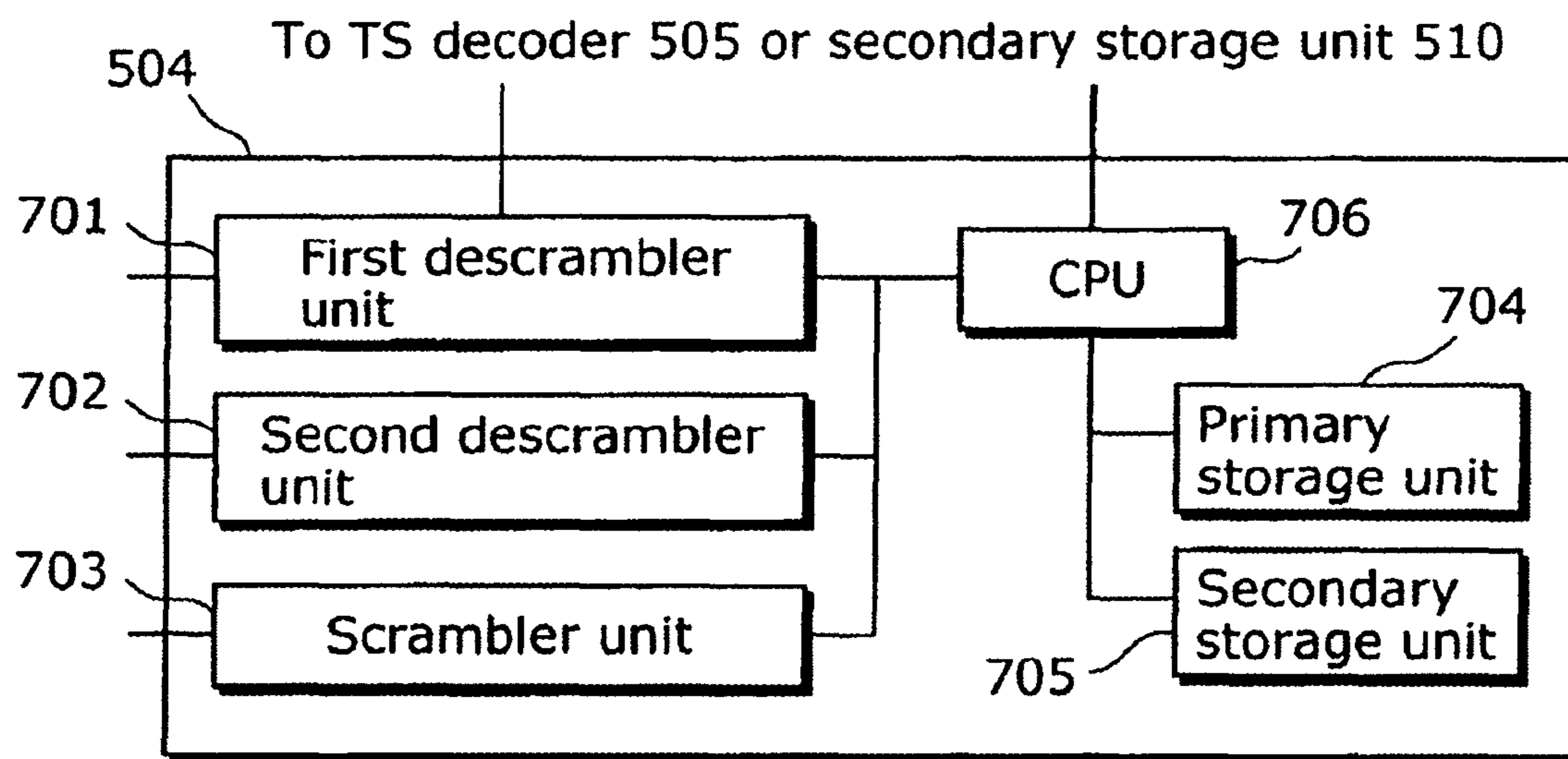



FIG. 9

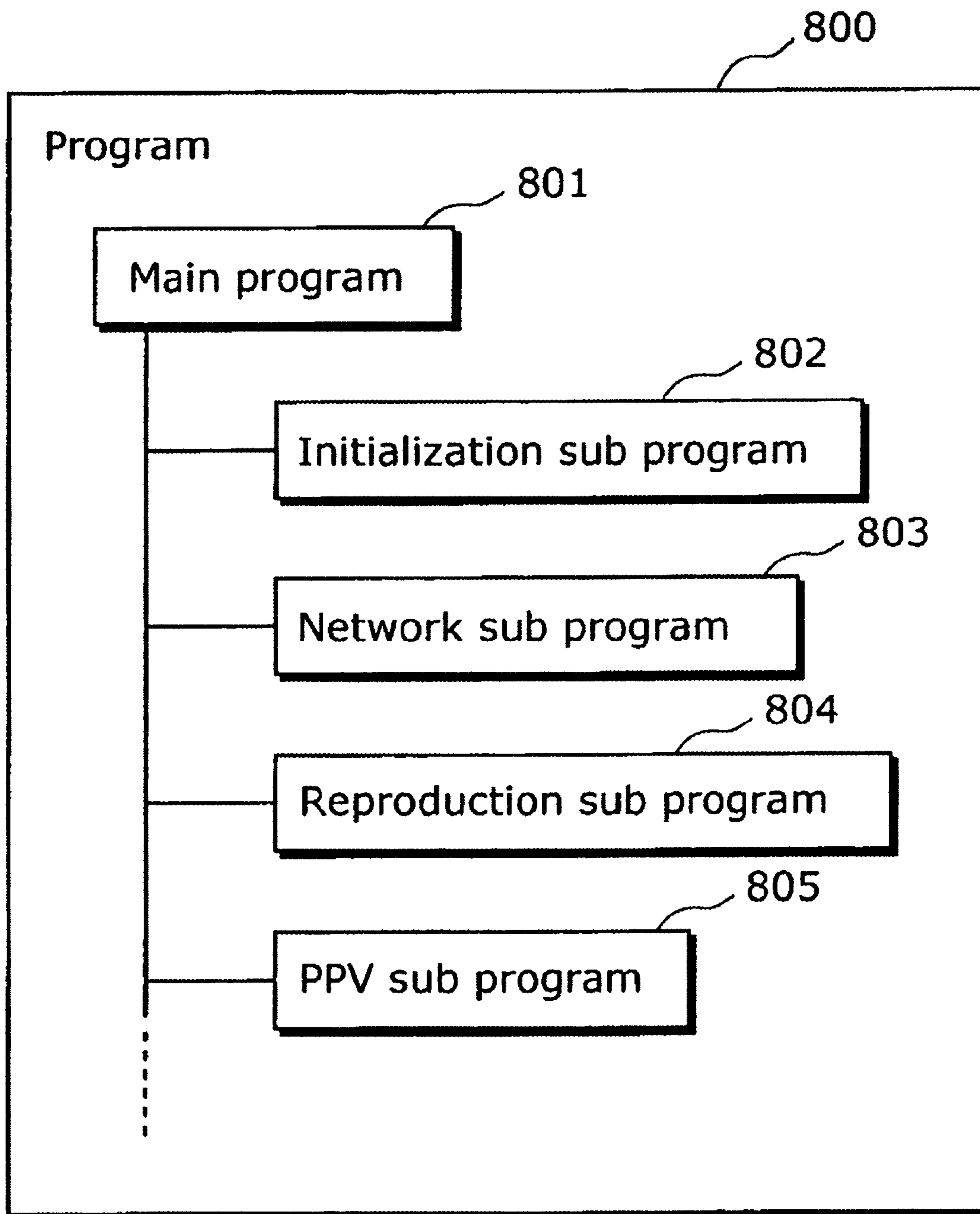

FIG. 10

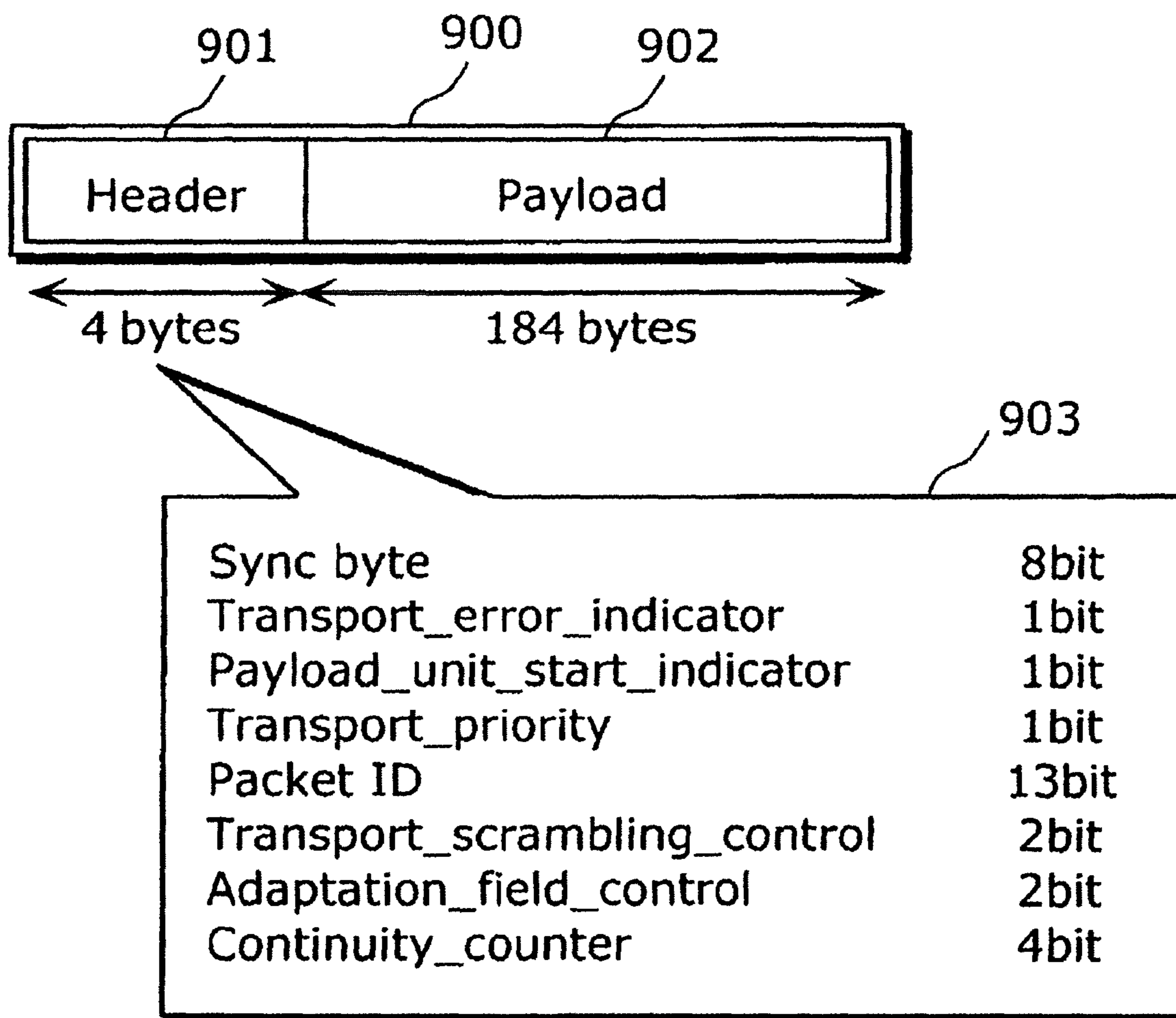

FIG. 11

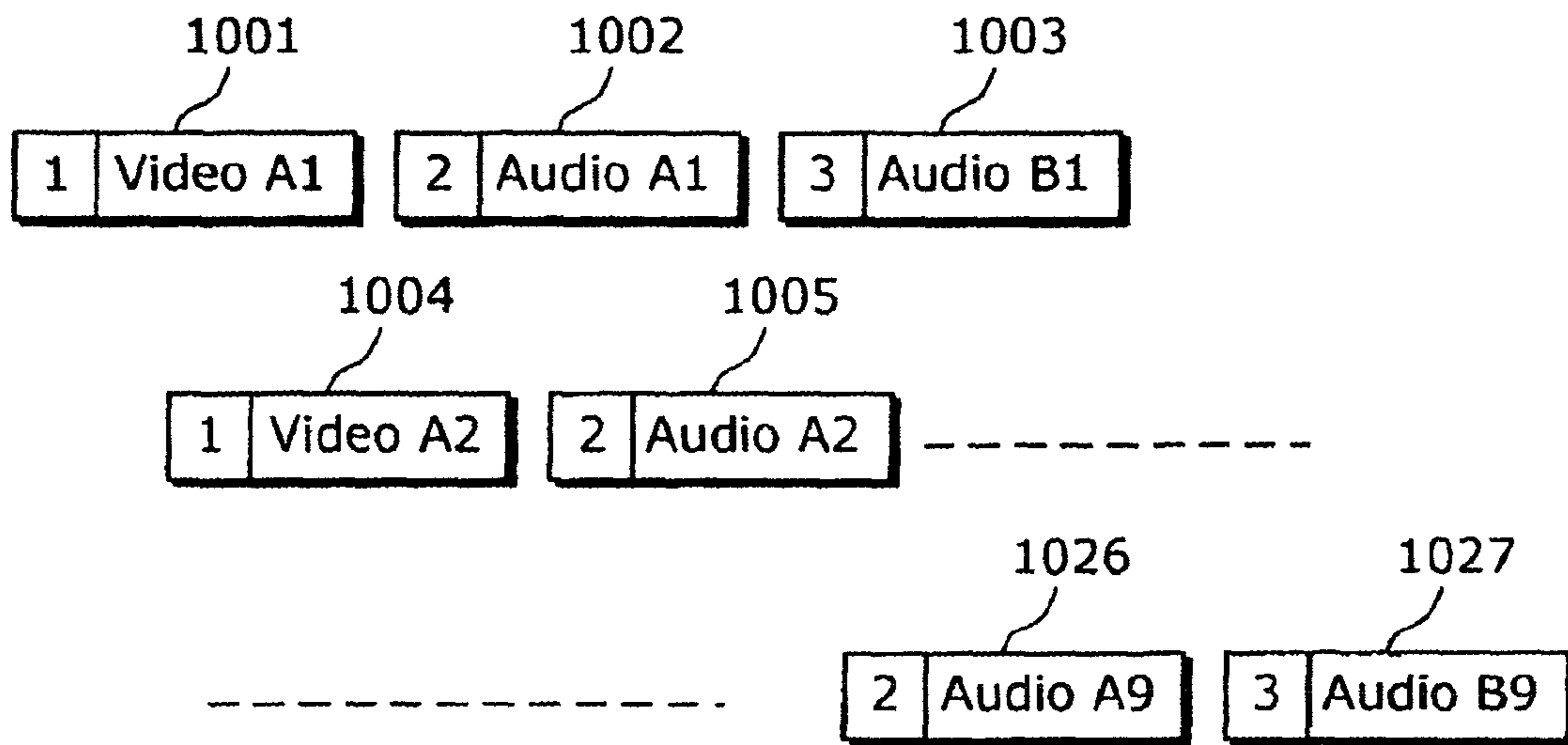

FIG. 12

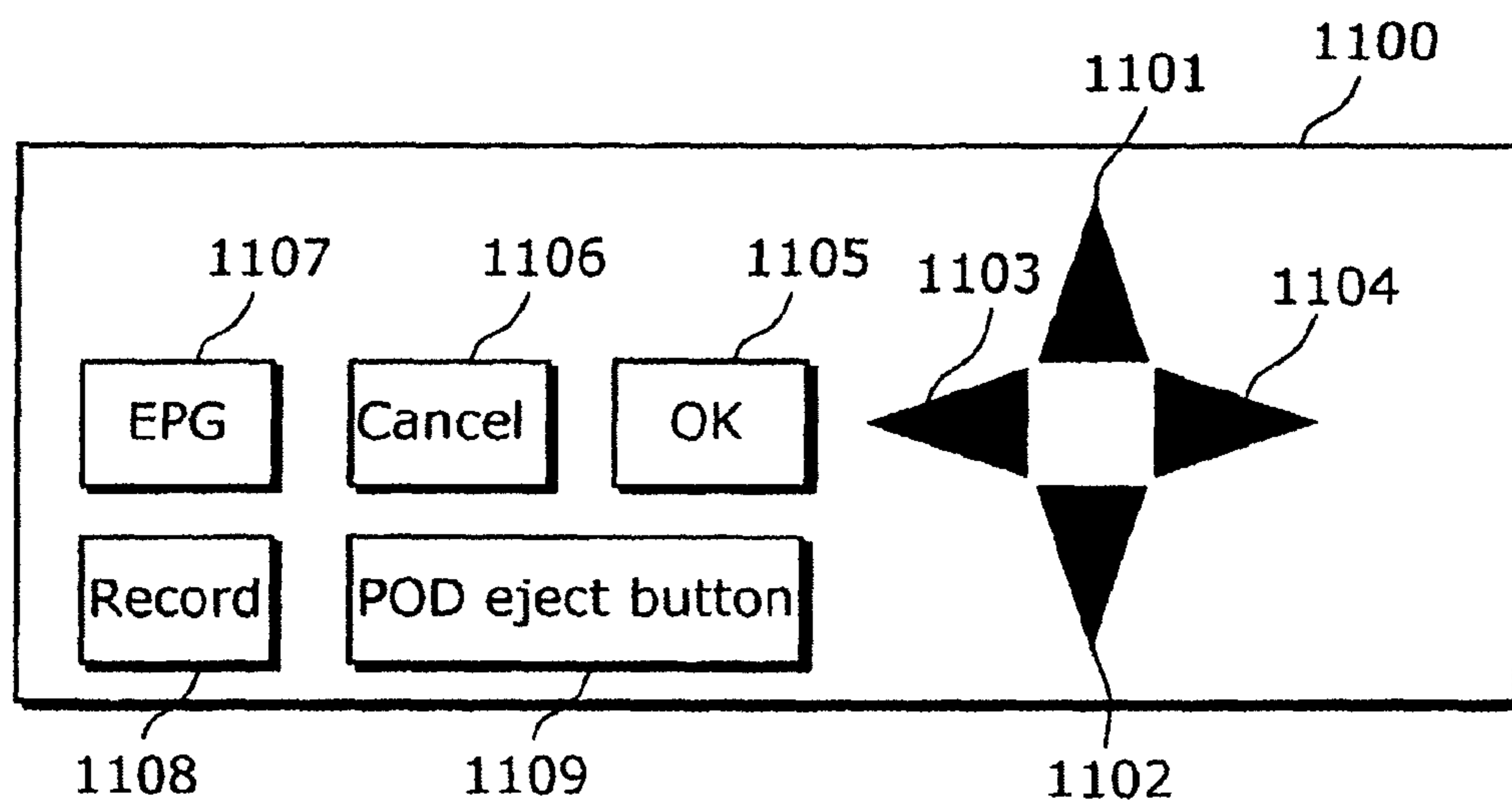

FIG. 13

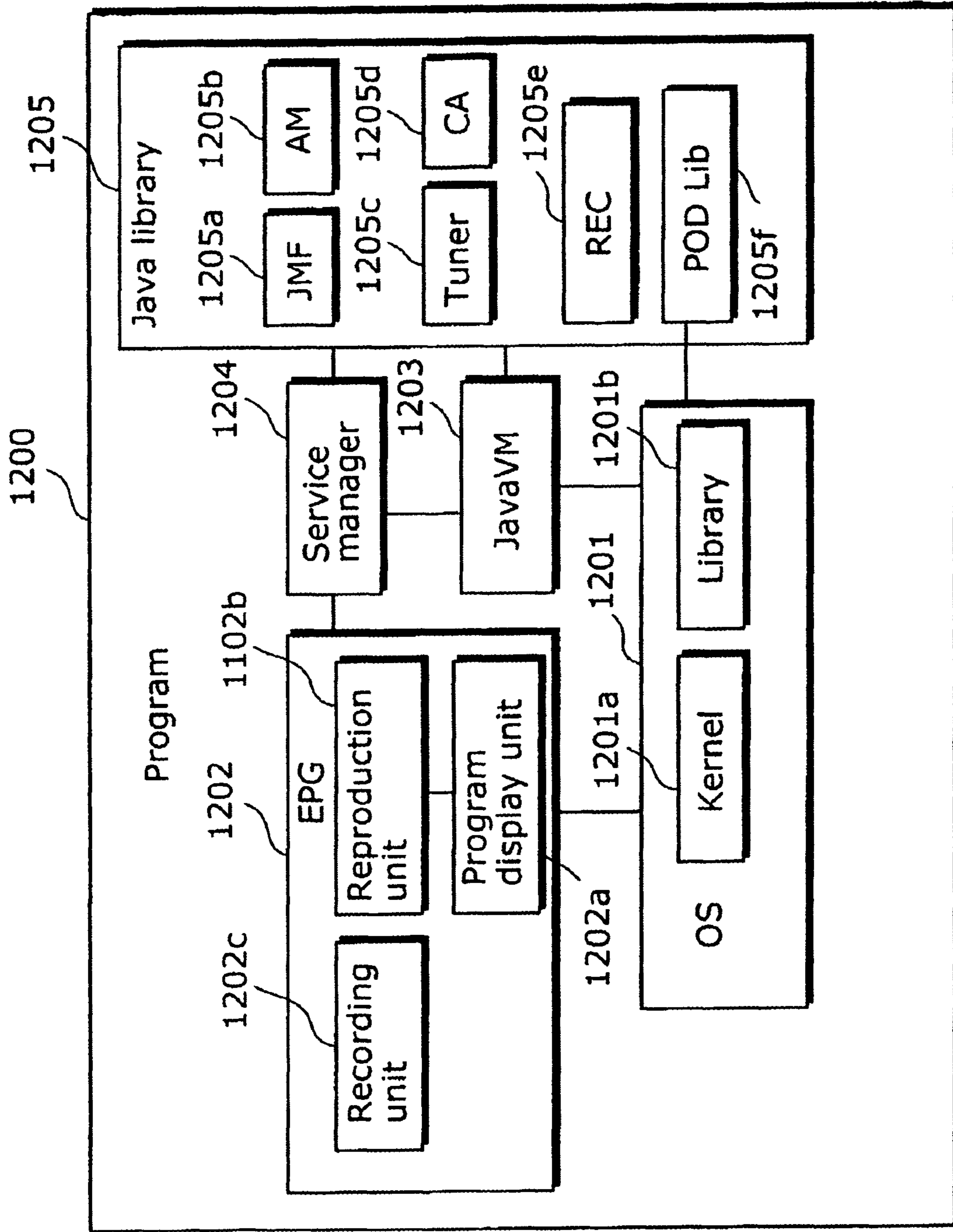

FIG. 14A

Time	Channel 1	Channel 2
9:00-10:00	News 9	Cinema BBB
10:00-11:00	Cinema AAA	Cinema BBB
11:00-12:00	Cinema AAA	News 11

FIG. 14B

Time	Channel 1	Channel 2
9:00-10:00	News 9	Cinema BBB
10:00-11:00	Cinema AAA	Cinema BBB
11:00-12:00	Cinema AAA	News 11

FIG. 15A

Time	Channel 1	Channel 2
9:00-10:00	News 9	Cinema BBB
10:00-11:00		
11:00-12:00	Cinema AAA	News 11

FIG. 15B

Time	Channel 1	Channel 2
9:00-10:00	News 9	Cinema BBB
10:00-11:00		
11:00-12:00	Cinema AAA	News 11

FIG. 16

The diagram shows a table with four rows and four columns, enclosed in a rounded rectangular frame. The table is labeled with reference numerals: 1501, 1502, 1503, and 1504 point to the columns; 1511, 1512, 1513, and 1514 point to the rows; and 609 points to the entire table structure.

1	Channel 1	150MHz,....	101
2	Channel 2	156MHz,....	102
3	TV3	216MHz,....	103
4	TV Japan	222MHz,....	104

FIG. 17A

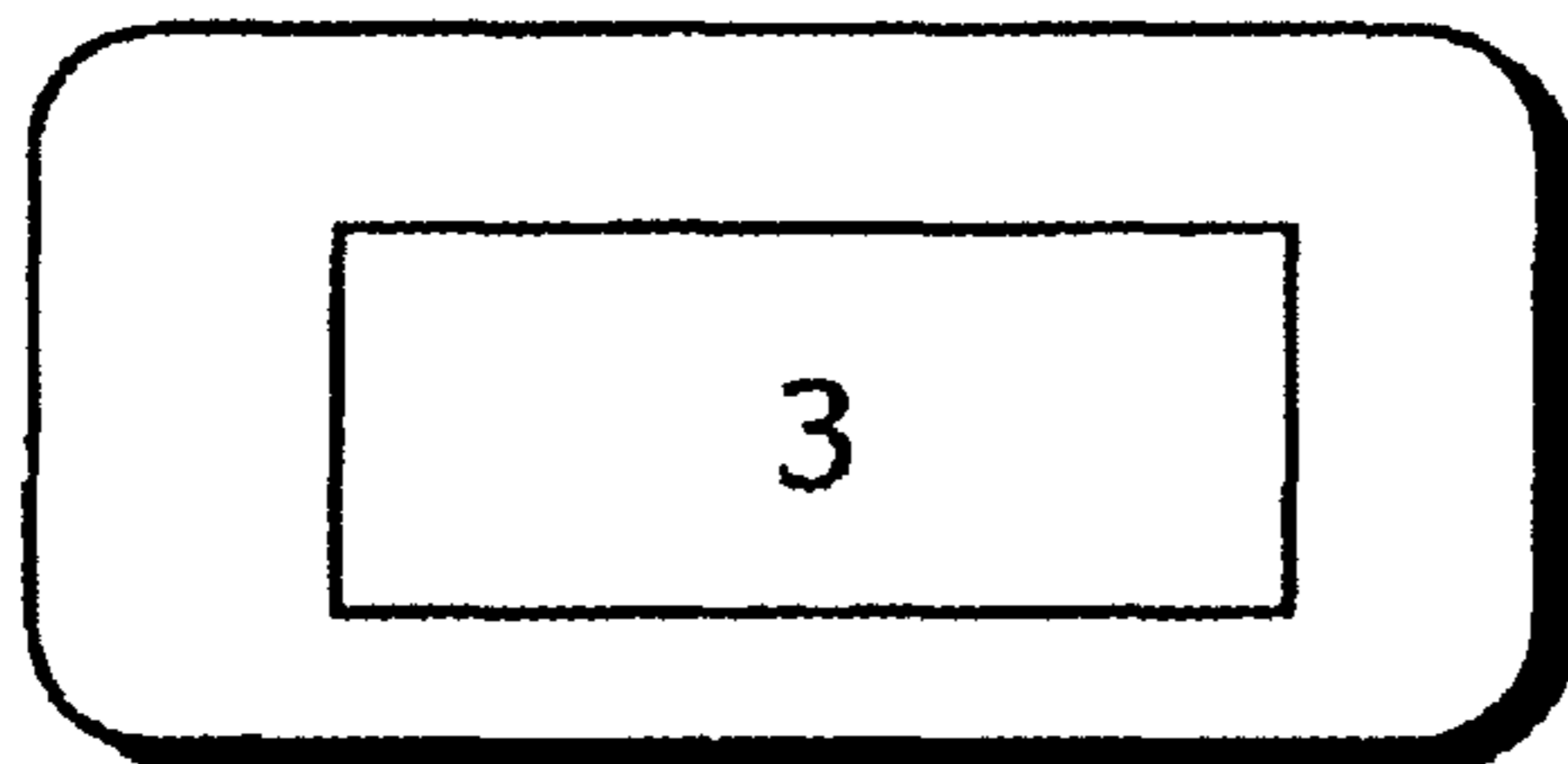

FIG. 17B

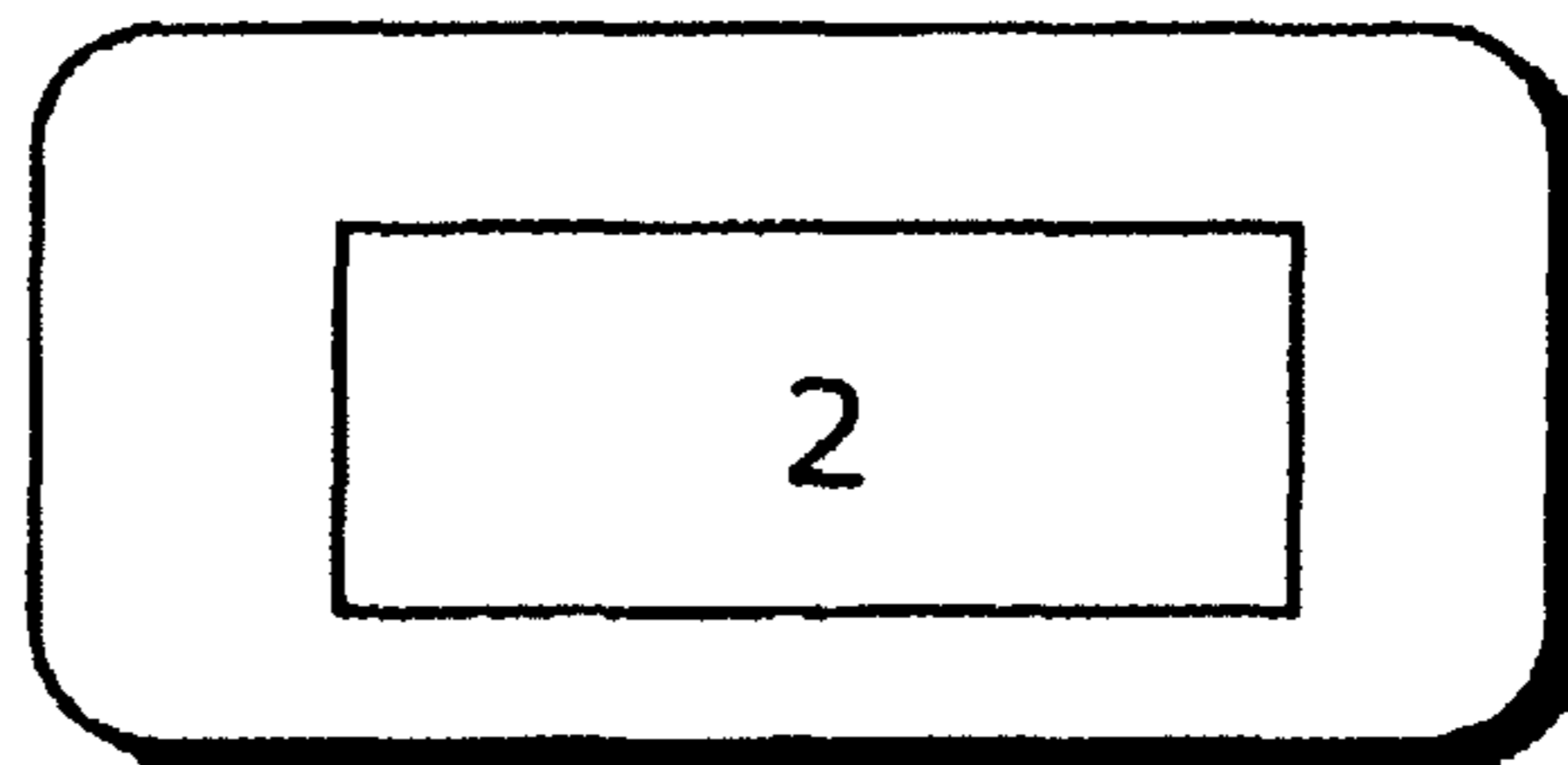

FIG. 17C

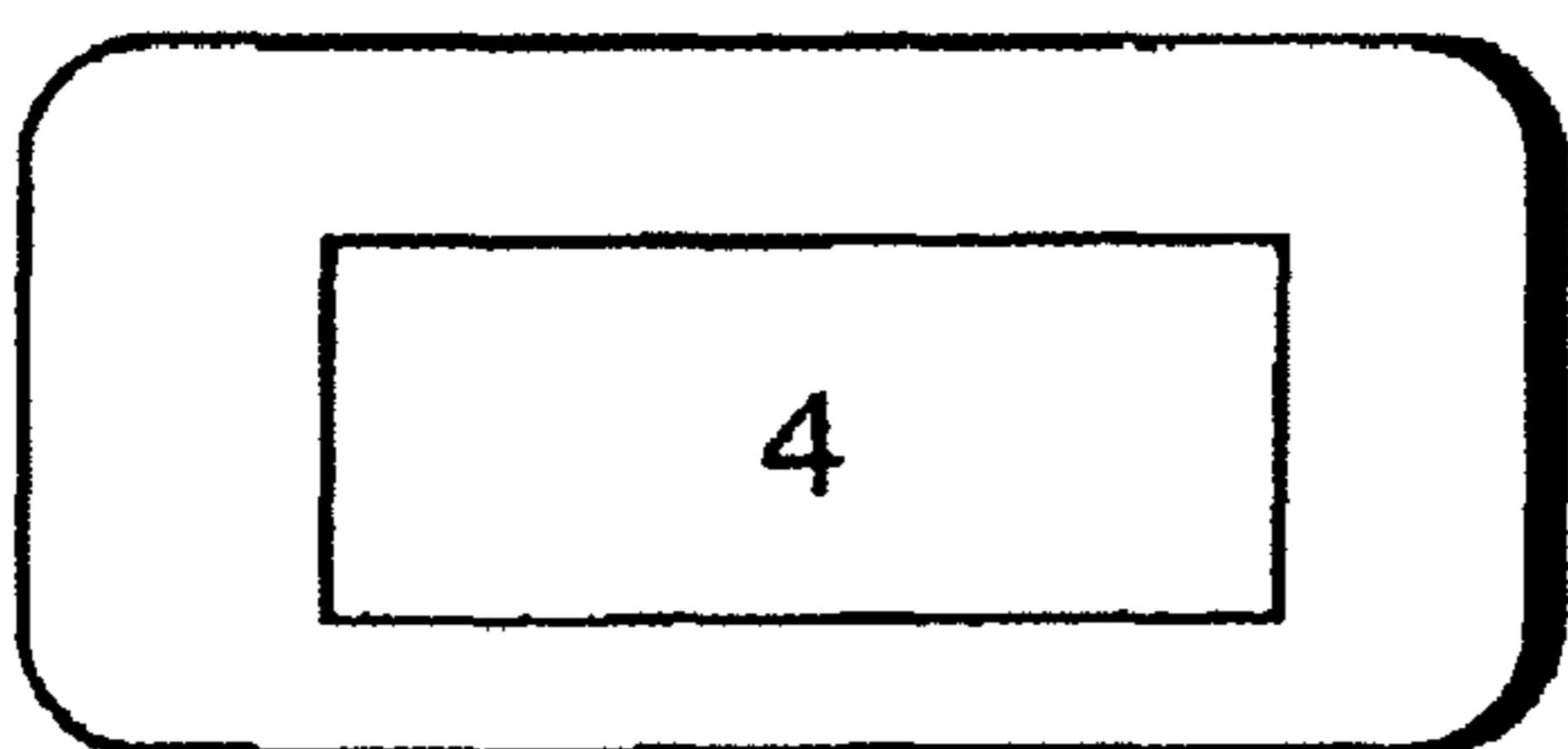

FIG. 18A

	1701	1702	1703	1704	1705	1706	1707
1708	Recording number	Channel	Recording start time	Recording end time	Execution status	Scramble	Problem during recording
1709	1	2	2004/3/10 9:00	2004/3/10 11:00	2	1	1
	2	2	2004/3/10 11:00	2004/3/10 12:00	0	1	0

FIG. 18B

	1701	1702	1703	1704	1705	1706	1707
1708	Recording number	Channel	Recording start time	Recording end time	Execution status	Scramble	Problem during recording
1709	1	2	2004/3/10 9:00	2004/3/10 11:00	2	1	1
	2	2	2004/3/10 11:00	2004/3/10 12:00	1	1	0



FIG. 19

	1801	1802
1811	101	501
1812	102	502
1813	103	503

FIG. 20

	1901	1902	1903
1911	Audio	5011	
1912	Video	5012	
1913	Data	5013	AIT
1914	Data	5014	DSMCC[1]

FIG. 21

	Java program identifier 2001	Control information 2002	DSMCC identifier 2003	Program name 2004
2011	0x301	autostart	1	/a/TopXlet
2012	0x302	present	1	/b/GameXlet

FIG. 22

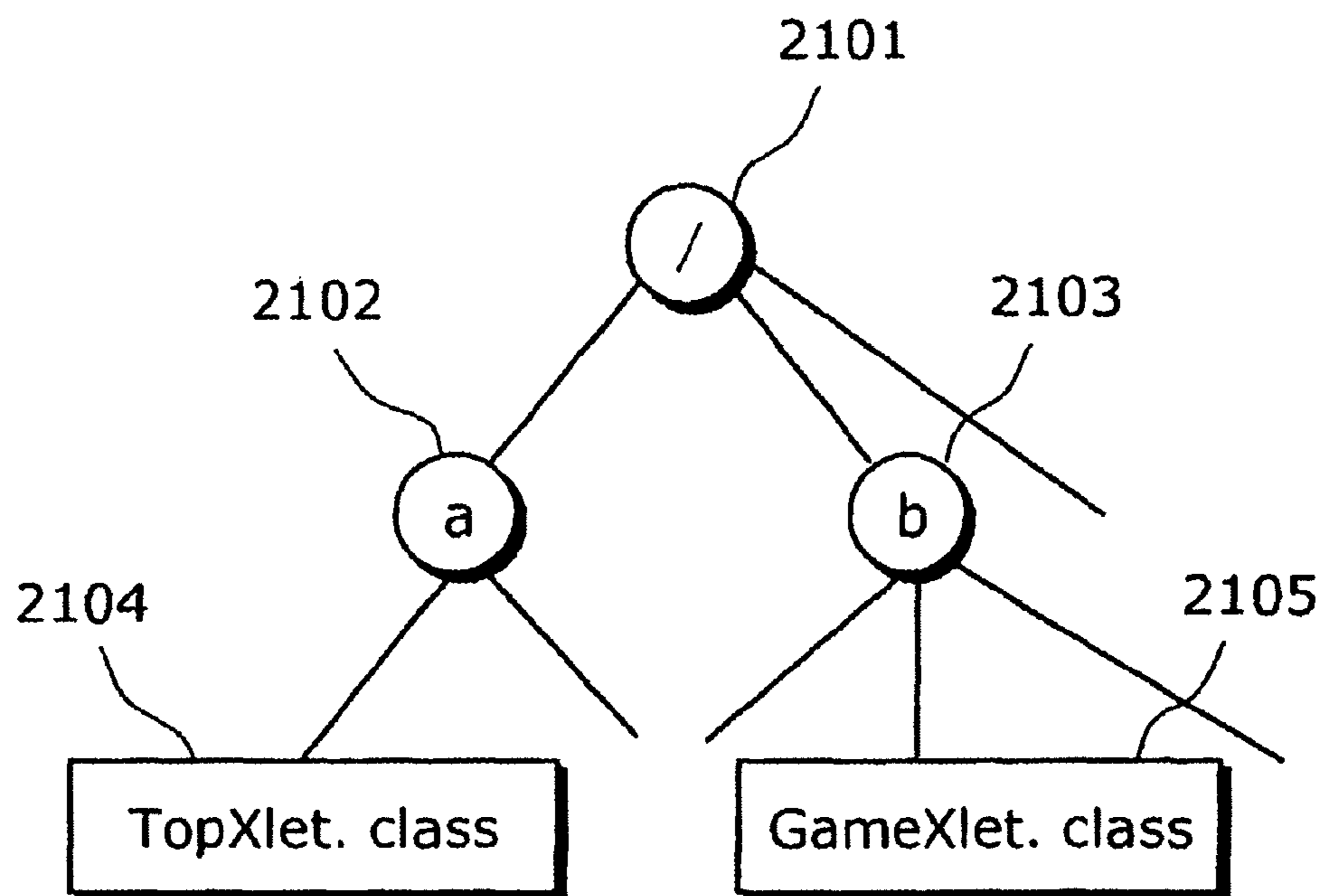

FIG. 23

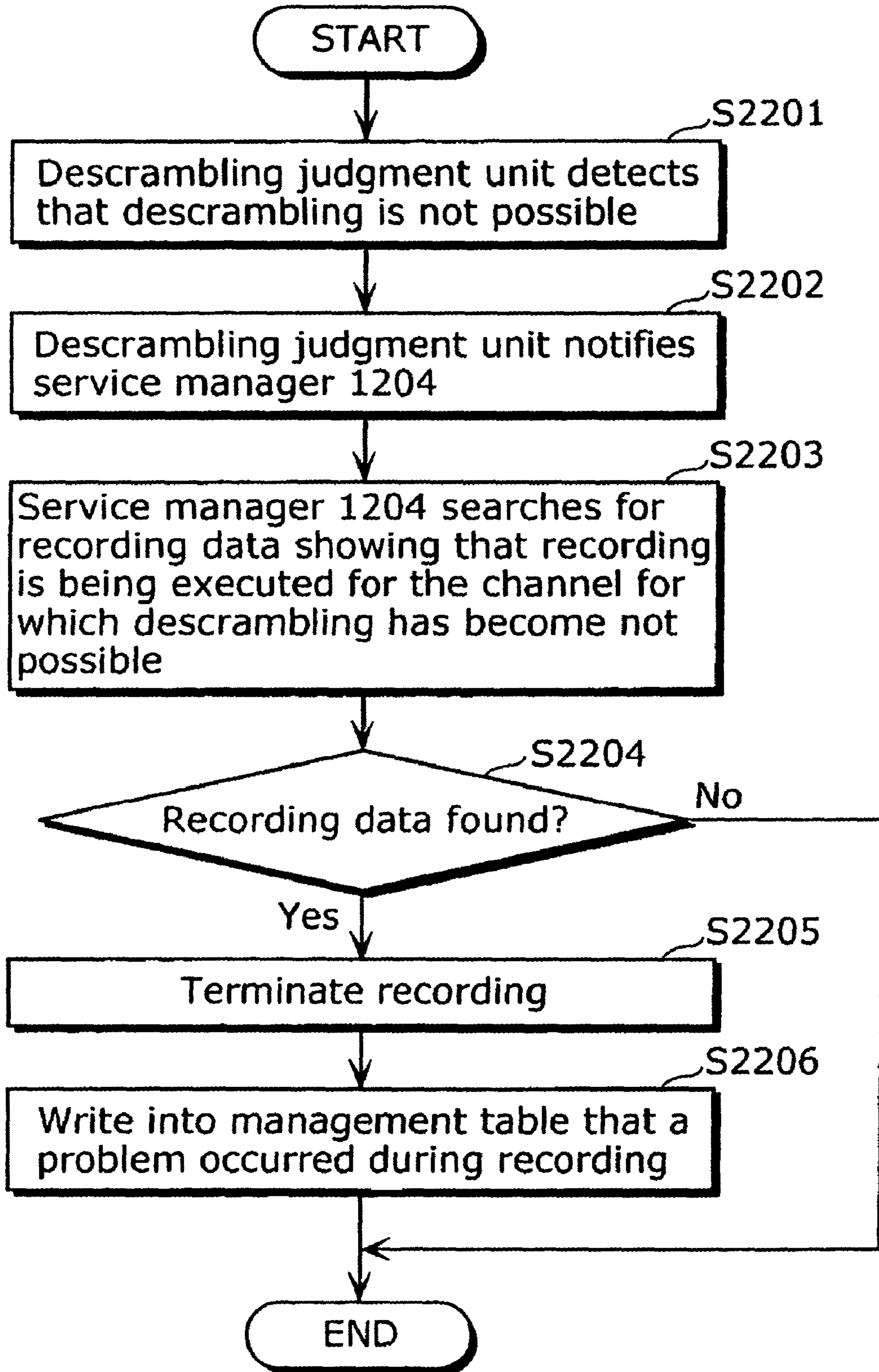

FIG. 24

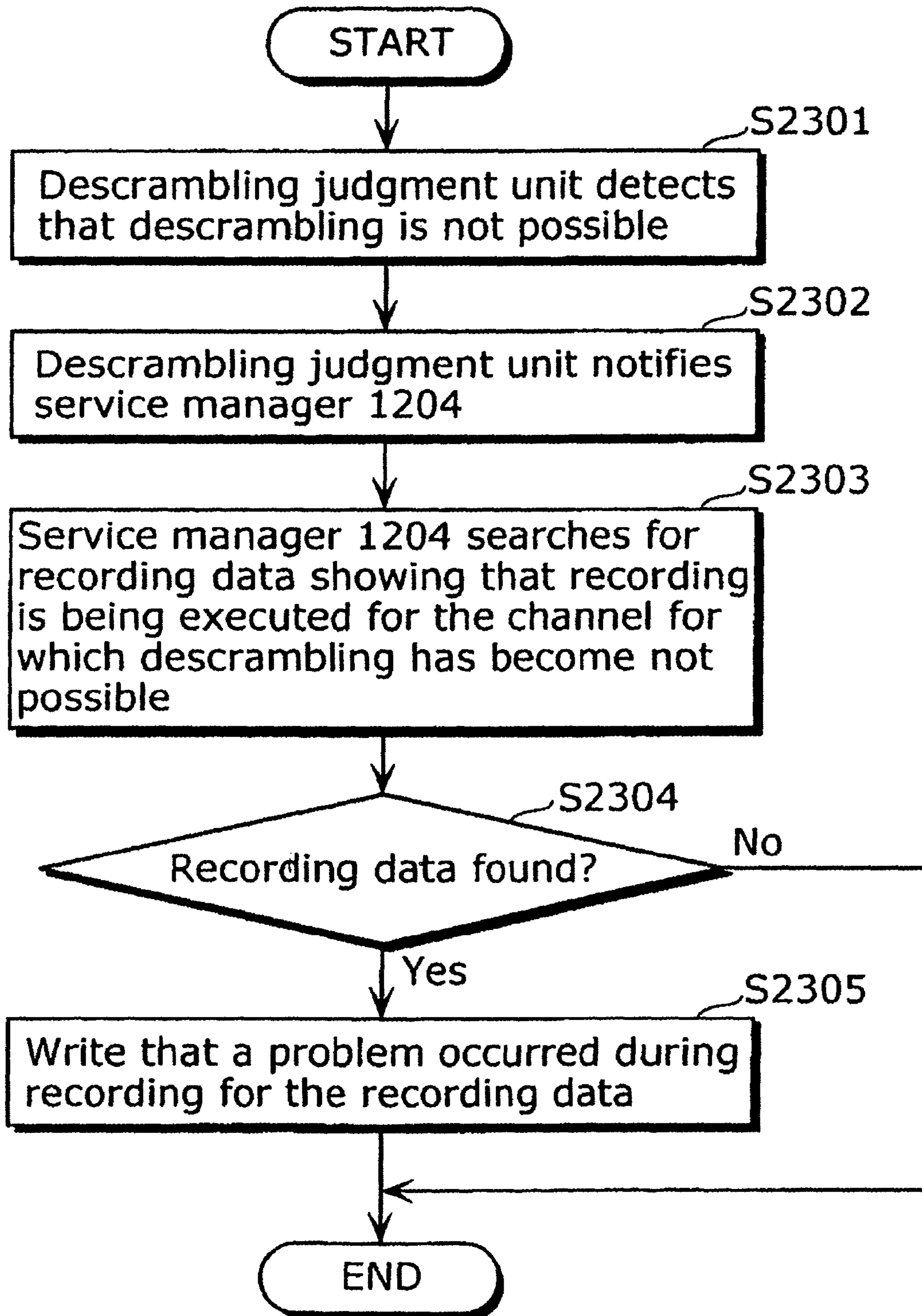

FIG. 25

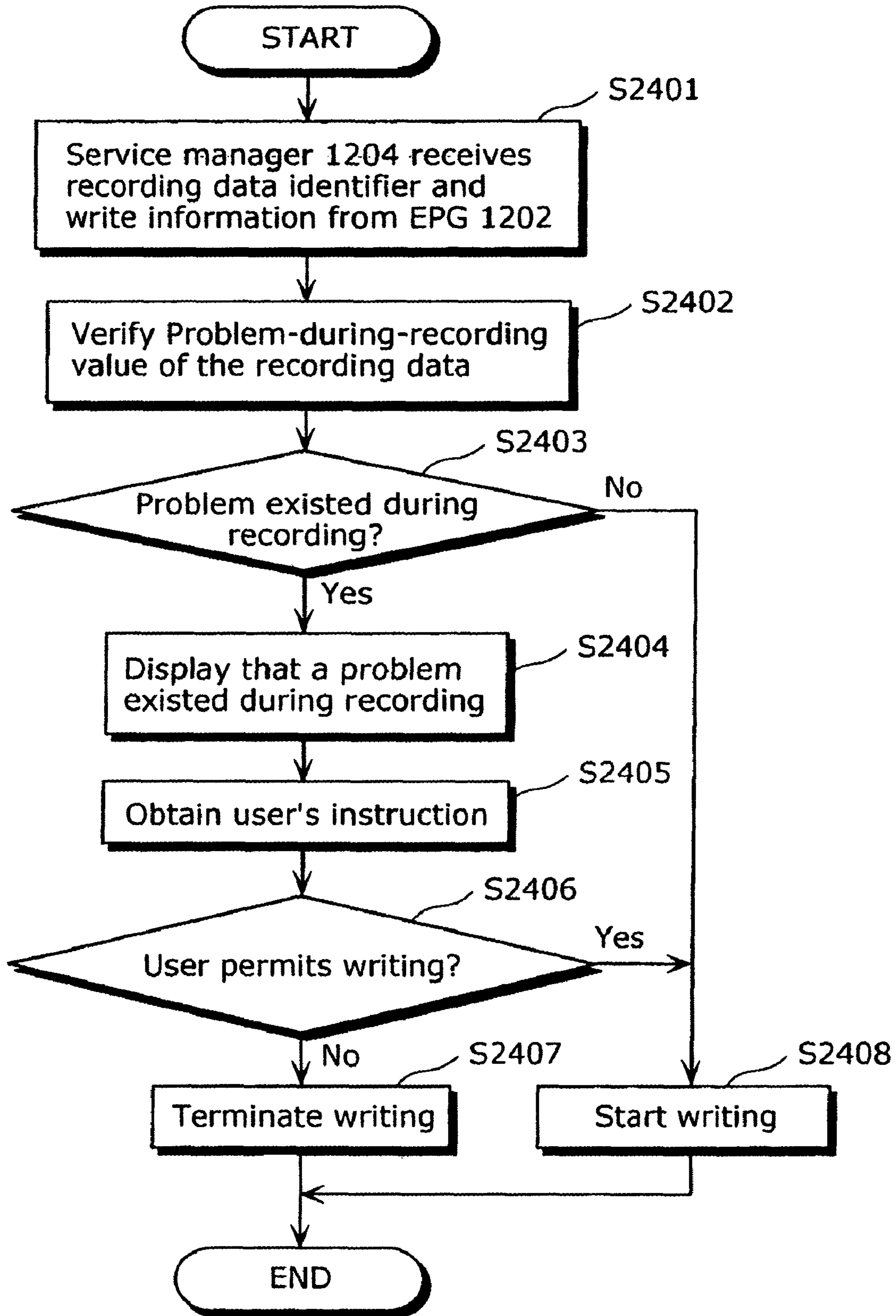

FIG. 26

The diagram shows a large rectangular container labeled 609. Inside this container is a table with two rows and three columns. The columns are labeled 2501, 2502, and 2503. The first row contains the headers 'Recording number', 'Program name', and 'Problem during recording'. The second row contains the values '1', 'Cinema BBB', and '1'. A label 2504 points to the entire table structure.

Recording number	Program name	Problem during recording
1	Cinema BBB	1

FIG. 27

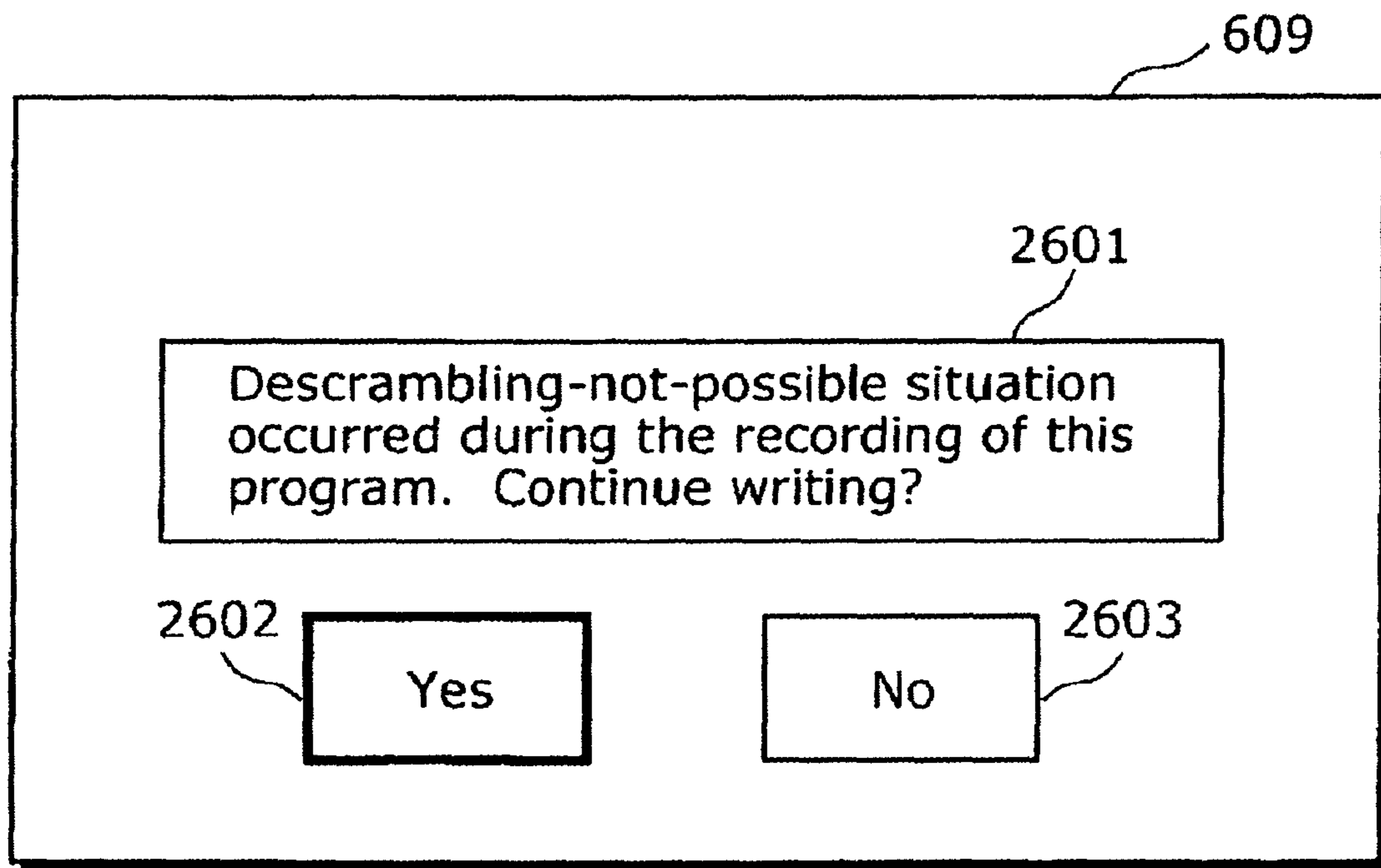

FIG. 28

	1701	1702	1703	1704	1705	1706	1707	1708	1709
	Recording number	Channel	Recording start time	Recording end time	Execution status	Scramble	Problem during recording	Problem period	Cause
1708	1	2	2004/3/10 9:00	2004/3/10 11:00	2	1	1	9:35~9:40	2
								10:10~10:30	1
								⋮	⋮
1709	2	2004/3/10 11:00	2004/3/10 12:00	0	1	0	—	—	
							—	—	



FIG. 29

609

2601

Descrambling-not-possible situation occurred during the recording of this program. Continue writing?

2801

Problem period: 15 minutes

2802

Cause of problem: Removal of POD card

2602

Yes

No

2603

The figure shows a rectangular window with a title bar (609) and a main content area (2601). The content area contains a text box with the question: "Descrambling-not-possible situation occurred during the recording of this program. Continue writing?". Below this is a text box (2801) containing "Problem period: 15 minutes". Below that is another text box (2802) containing "Cause of problem: Removal of POD card". At the bottom of the window are two buttons: "Yes" (2602) and "No" (2603).

FIG. 30A

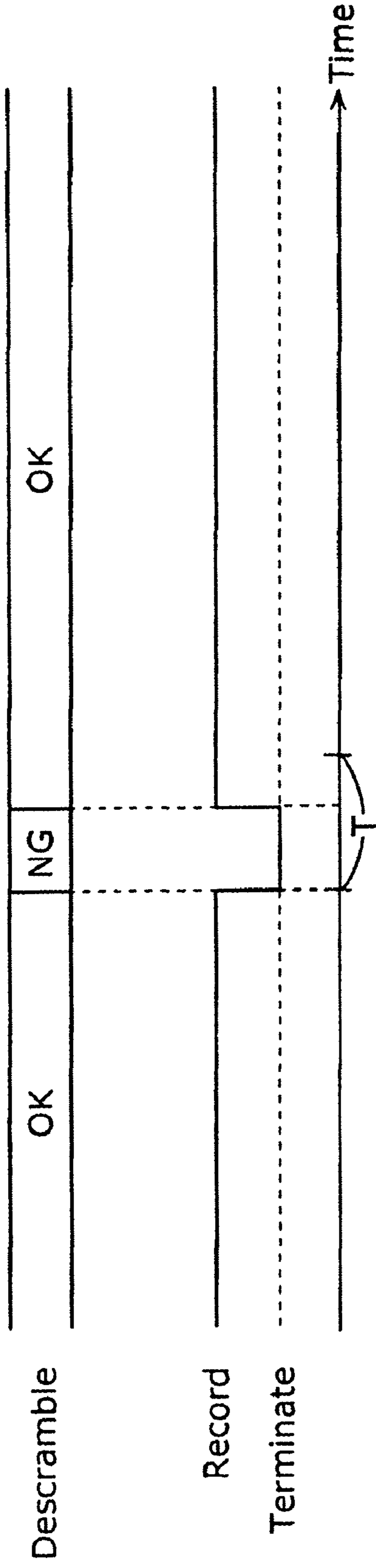

FIG. 30B

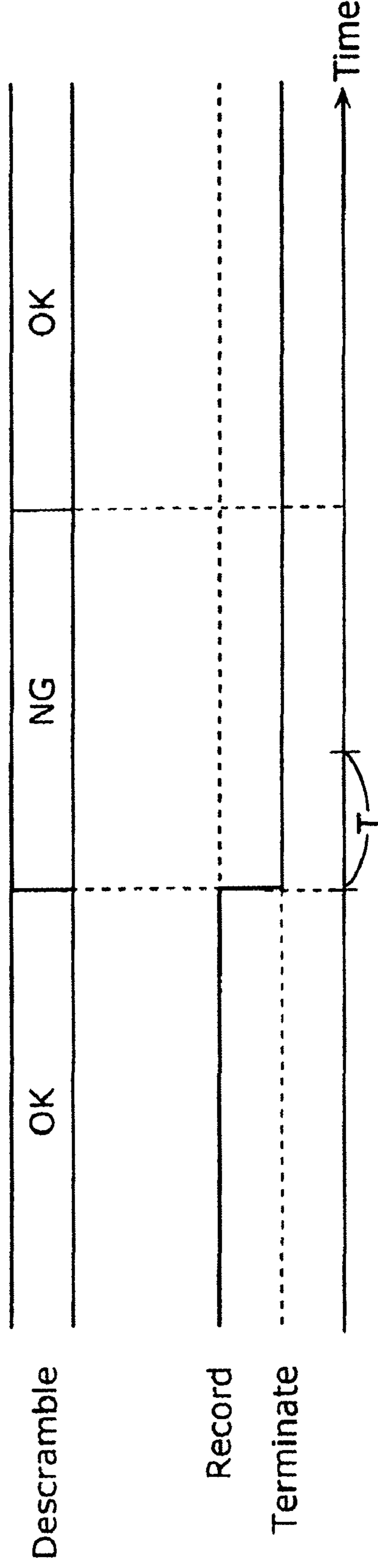

FIG. 31

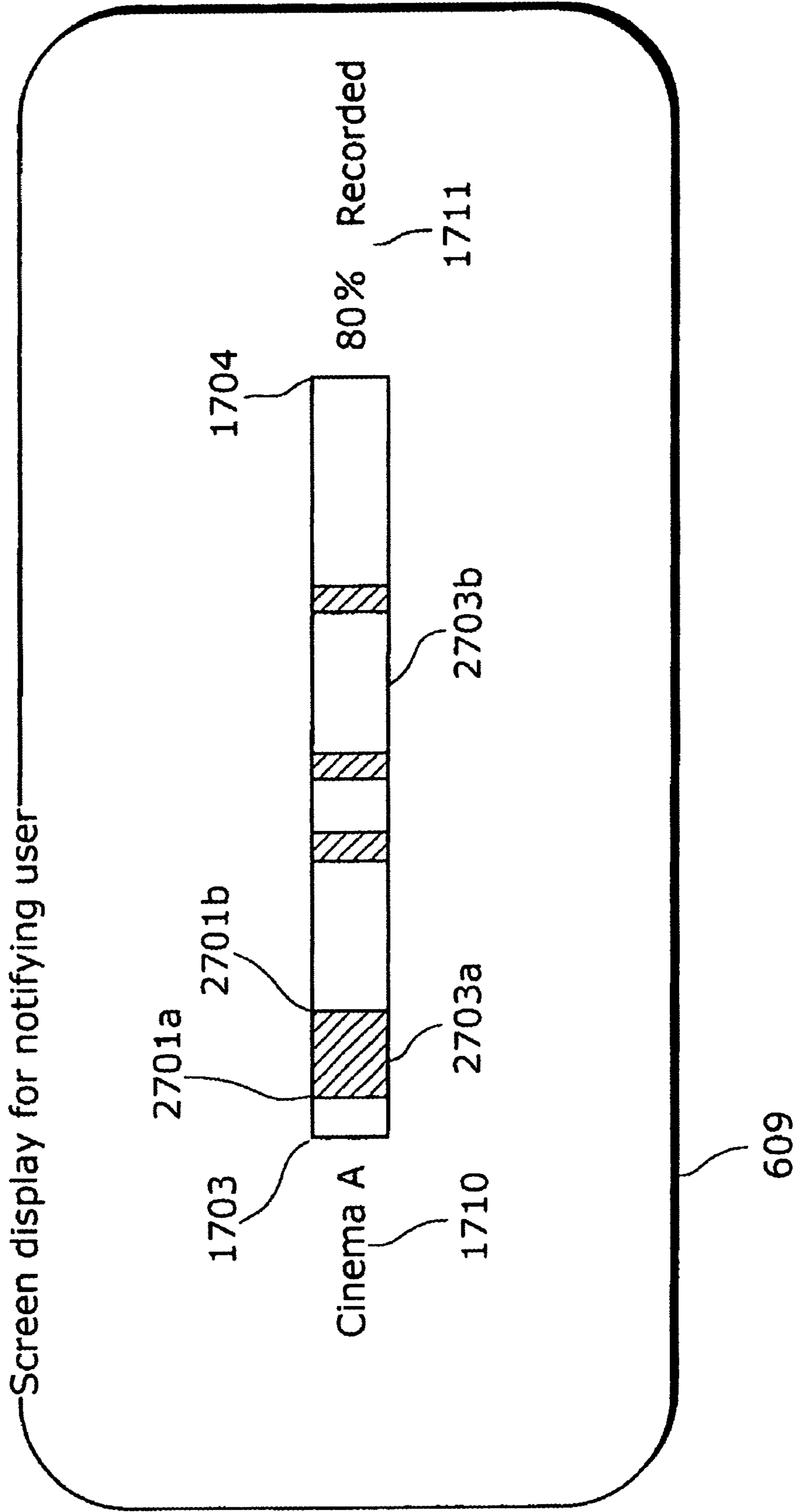

FIG. 32

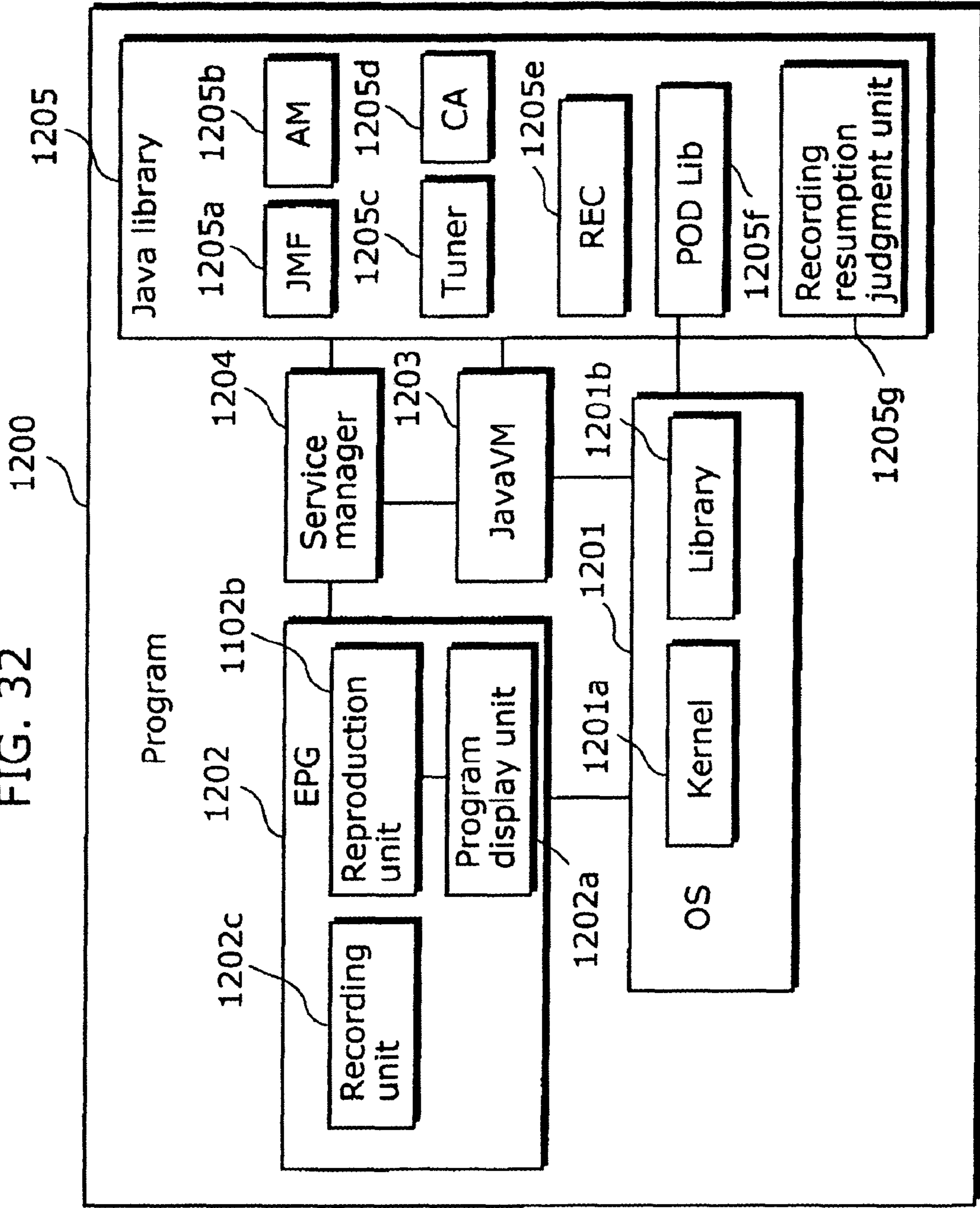

FIG. 33

1701	1702	1703	1704	1705	1706	1707	1708	1709
Recording number	Channel	Recording start time	Recording end time	Execution status	Scramble	Problem during recording	Problem period	Cause
1	2	2004/3/10 9:00	2004/3/10 11:00	3	1	1	9:35~9:40 10:10~10:30 ..... 10:40~	1
2	2	2004/3/10 11:00	2004/3/10 12:00	0	1	0		0

FIG. 34

1701	1702	1703	1704	1705	1706	1707	1708	1709	2701	2702
Recording number	Channel	Recording start time	Recording end time	Execution status	Scramble	Problem during recording	Problem period	Cause		
1	2	2004/3/10 9:00	2004/3/10 11:00	3	1	1	9:35~9:40 10:10~10:30 ..... 10:40~10:45	1		
2	2	2004/3/10 11:00	2004/3/10 12:00	1	1	0		0		

FIG. 35

1701	1702	1703	1704	1705	1706	1707	1708	1709
Recording number	Channel	Recording start time	Recording end time	Execution status	Scramble	Problem during recording	Problem period	Cause
1	2	2004/3/10 9:00	2004/3/10 11:00	4	1	1	9:35~9:40 10:10~10:30 ..... 10:40~10:45	1
2	2	2004/3/10 11:00	2004/3/10 12:00	1	1	0		0

FIG. 36

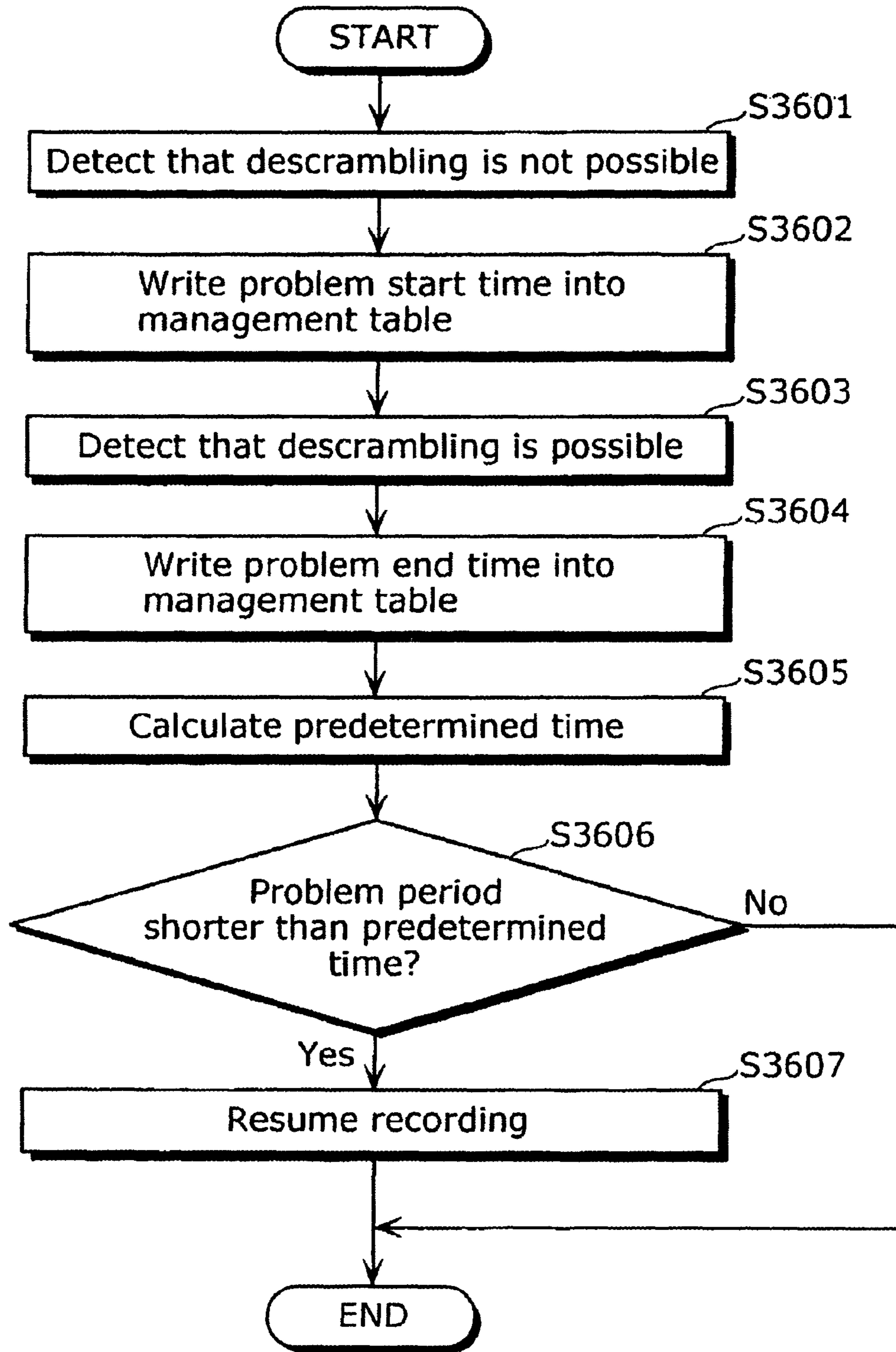



FIG. 37

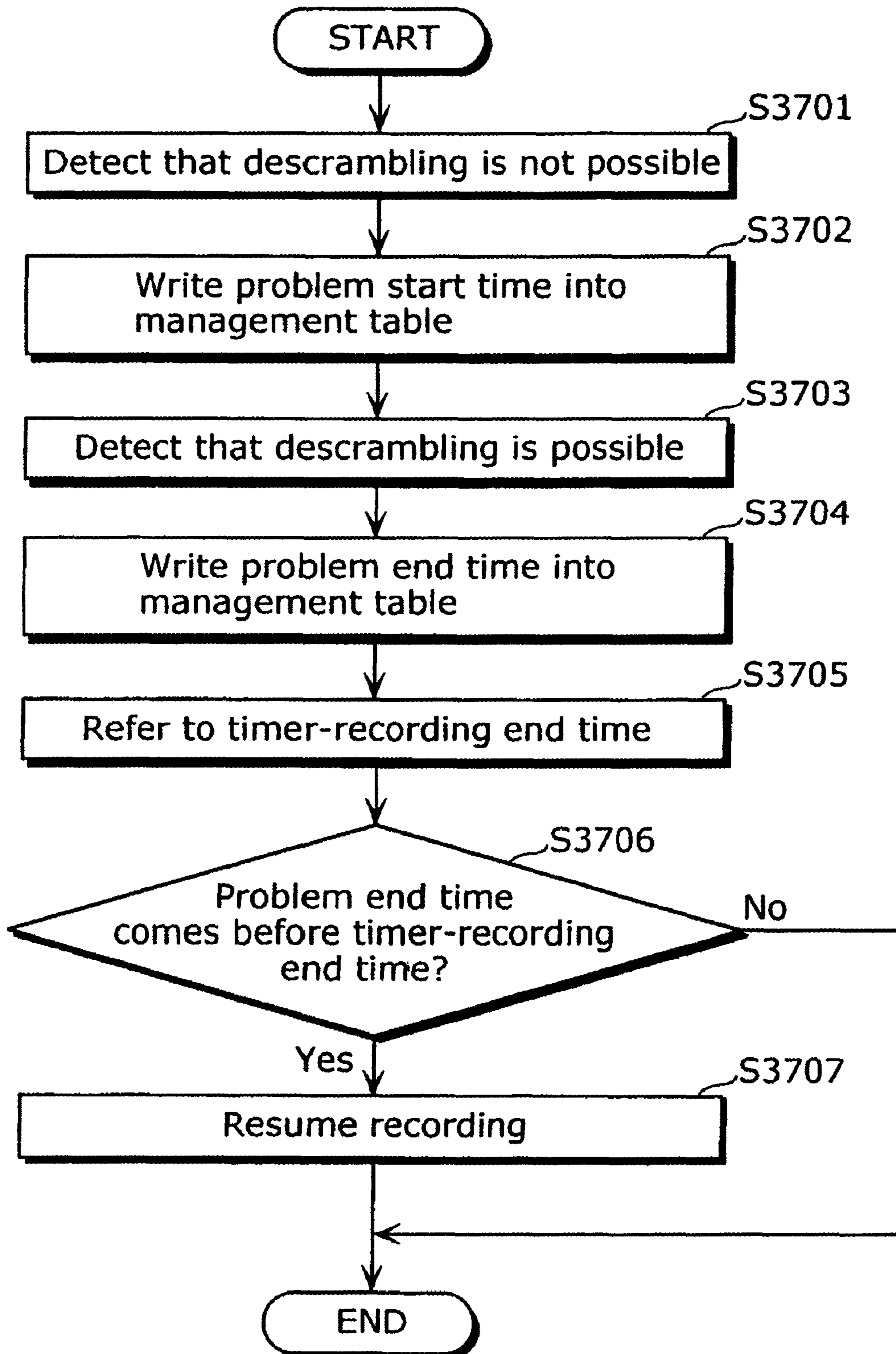

FIG. 38

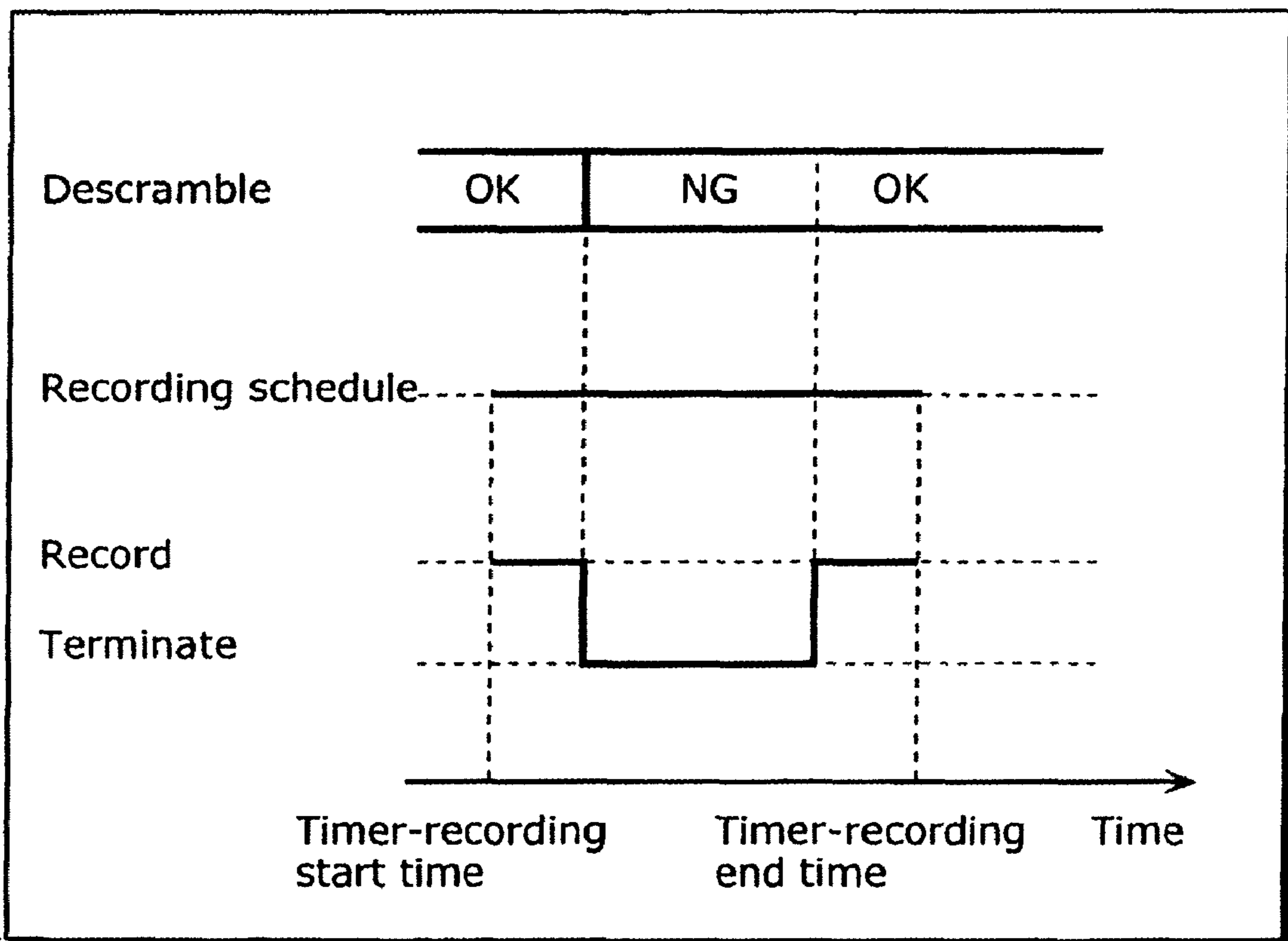

FIG. 39

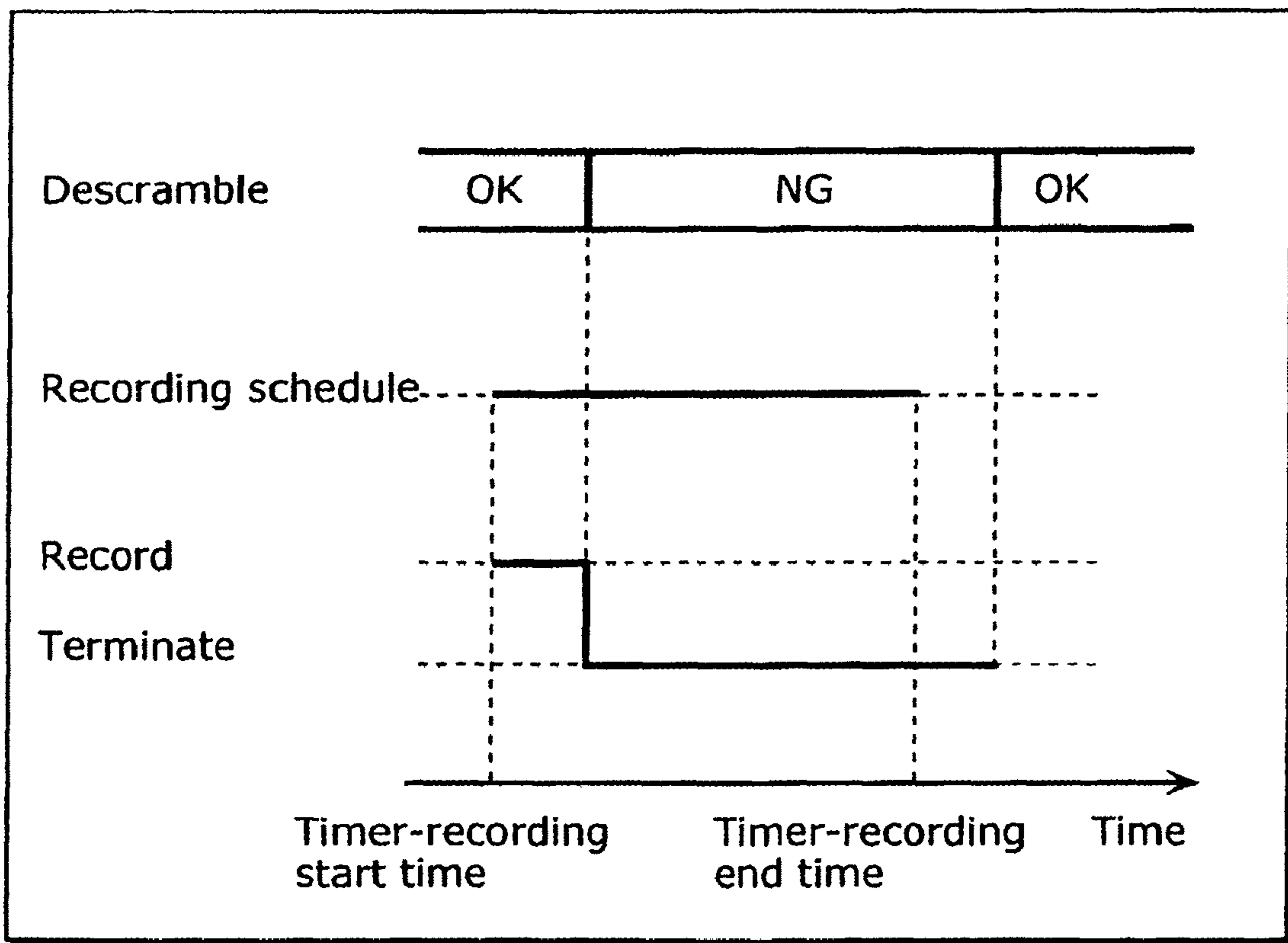

FIG. 40

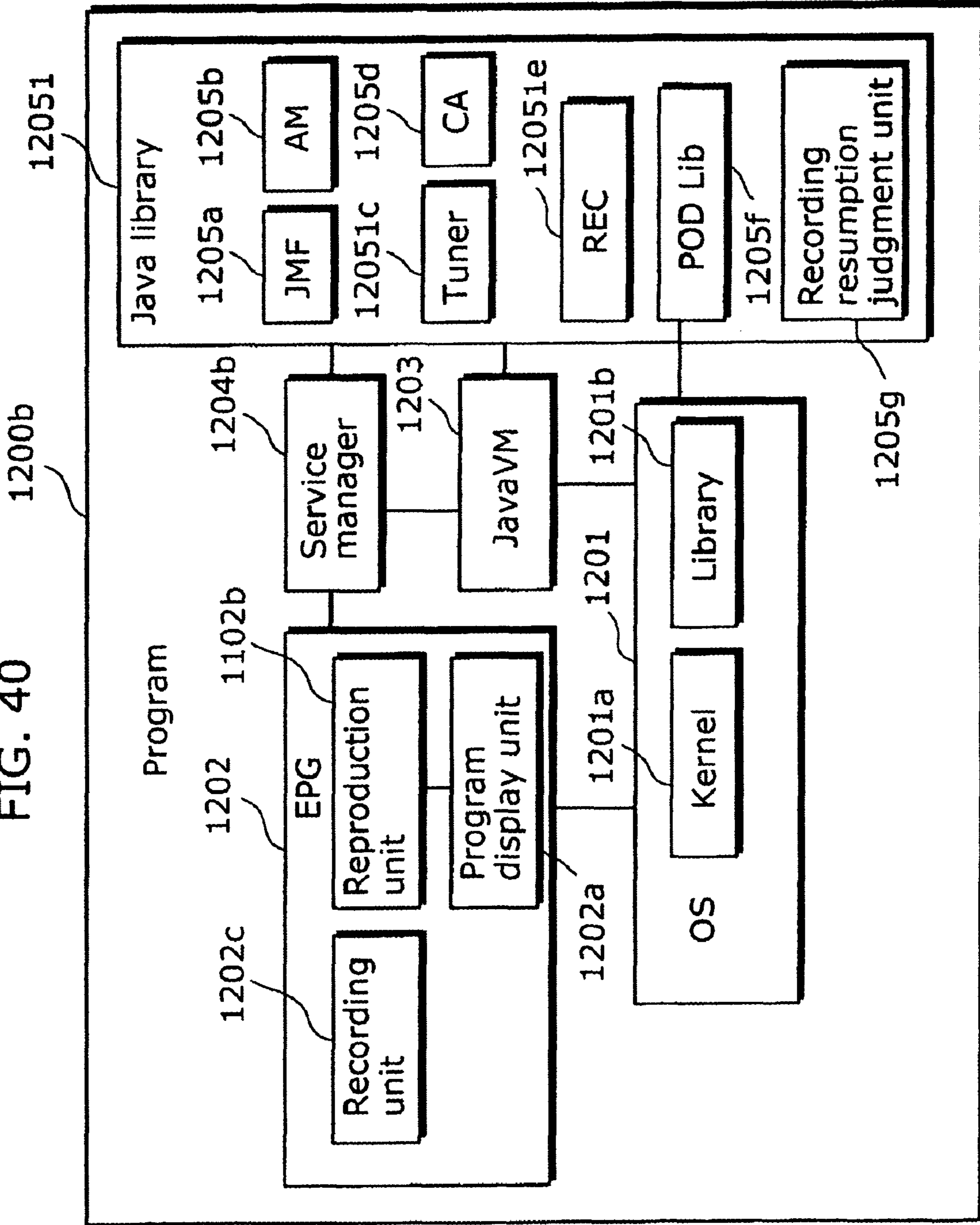

FIG. 41

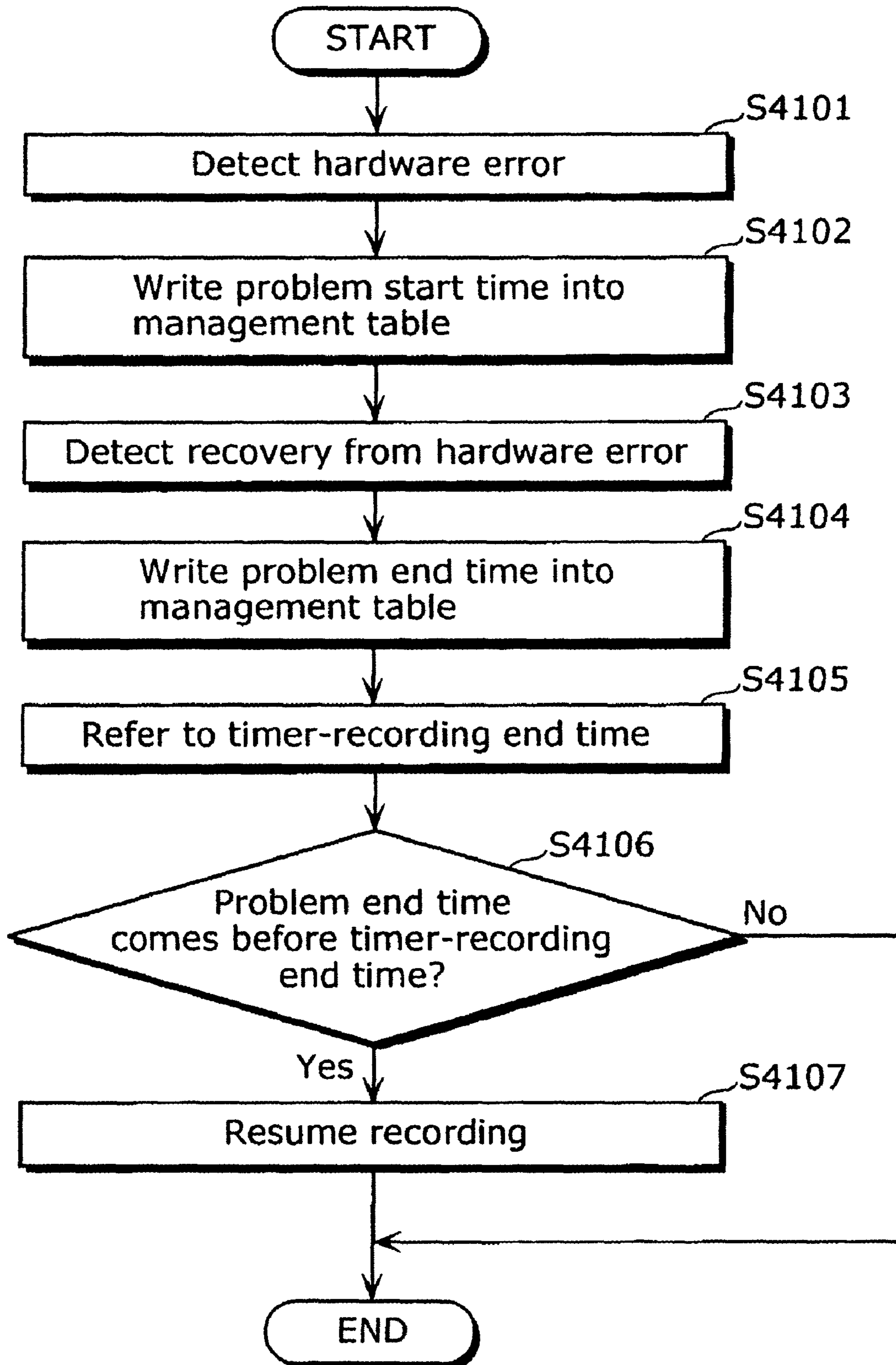
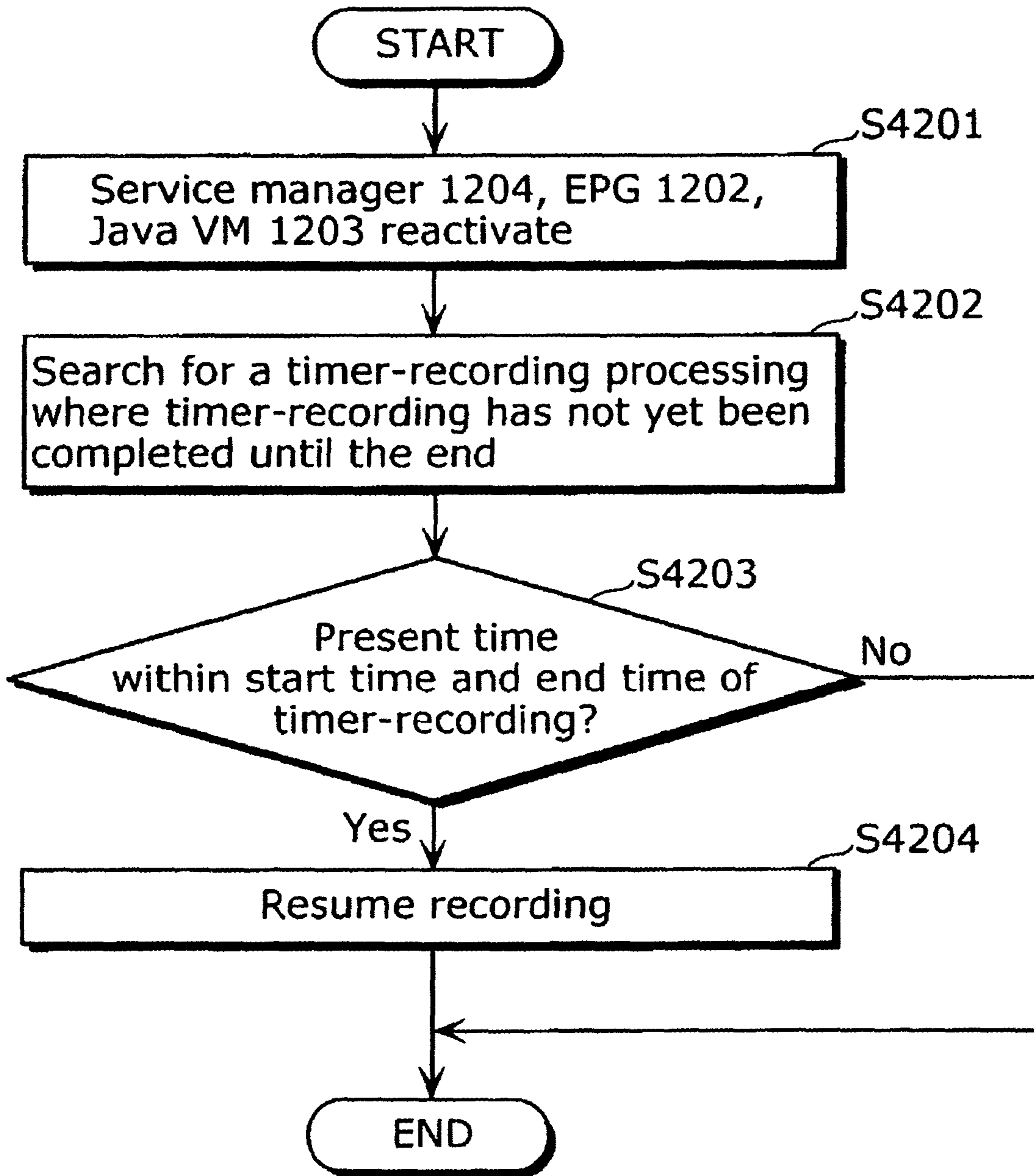

FIG. 42



## DIGITAL BROADCAST RECORDING APPARATUS

**Matter enclosed in heavy brackets [ ] appears in the original patent but forms no part of this reissue specification; matter printed in italics indicates the additions made by reissue.**

### BACKGROUND OF THE INVENTION

#### (1) Field of the Invention

The present invention relates to a digital broadcast recording apparatus which receives a scrambled digital broadcast, and particularly to a digital broadcast recording apparatus which performs recording processes such as timer-recording of a program and the like, or to a digital broadcast recording apparatus having a built-in reproduction function (also known as digital broadcast recording reproduction apparatus).

#### (2) Description of the Related Art

In a digital broadcast, a pay program is scrambled and distributed. The distributed program can only be descrambled and then viewed on a terminal of a user who has paid a viewing fee.

This descrambling function ceases to function on specific conditions. For example, when a contract term with a broadcast operator expires, or when an IC card or descrambling module which authenticates a contract-holder is removed from a receiving terminal. In these cases, as the receiving terminal outputs a scrambled video, the user is annoyed, and in the case where a program is being recorded, unneeded scrambled video is recorded.

In the conventional technology, when descrambling is not possible in the receiving terminal for scrambled broadcasts, problems are avoided by switching the video output of the receiving terminal (for example, see Japanese Laid-Open Patent Application No. 10-215444 Publication). As shown in FIG. 1, the conventional method for responding to when descrambling is prohibited or not possible mainly includes: a step of judging whether or not a program on a current channel has become new (S3001), a step of judging whether or not the new program can be viewed (S3002), a step of receiving the current channel when viewing is possible (S3003), and a step of receiving a promotional channel when viewing is not possible (S3004).

Thus in the conventional technology, in the case where descrambling becomes not possible, the outputting of scrambled video is prevented by changing the channel to be received to a channel that can be descrambled or a channel that is not scrambled, and outputting such received channel.

However, although, in the conventional technology, the recording of a scrambled video can be avoided when descrambling becomes not possible during the recording of a scrambled video, the change to a video which is different from the original program presents a problem in that the recording becomes intermittent.

For that reason, when storing on a recording medium (an HD (hard disk), a re-writable optical disc, a (once only) recordable disc, a memory, and so on), unneeded recording appears intermittently. As a result, the existence of useless recording is confirmed while the viewer is viewing the recorded program. Aside from being very annoying, it puts a strain on the available capacity of storage media through the storing of unneeded and useless information onto the recording medium. In addition, when the recording medium to be used for storing is a recording medium such as a CD-R (Com-

pact Disc Recordable) or a DVD-R (Digital Versatile Disc Recordable) which can only be written-on once, it is possible that, at worst, the recording medium itself becomes useless as, in the case where the above-mentioned situation occurs, the area on which unneeded information is stored into can no longer be overwritten.

### SUMMARY OF THE INVENTION

Consequently, the present invention is conceived to solve the aforementioned conventional problem and has as an objective to provide a terminal apparatus which can prevent recording which is not required by the viewer, and which can recognize problems in the contents of a recorded program without the details of the recorded program being viewed by the viewer, in the situation in which descrambling becomes prohibited or not possible during the recording of a descrambled video.

In order to achieve the aforementioned objective, the digital broadcast recording apparatus according to the present invention is a digital broadcast recording apparatus including: a first demodulation unit which demodulates received scrambled data using information including a designated frequency, and to output the demodulated scrambled data; a descrambler unit which descrambles the scrambled data demodulated by said first demodulation unit, and to output an MPEG-2 transport stream; a retrieving unit which retrieves, from the MPEG-2 transport stream outputted by said descrambler unit, AV data and a file system which makes up an application; an execution unit which executes the application made up by the file system; a recording control unit which receives a record request from the executed application, and which controls recording according to the received record request; a recording unit which records the retrieved AV data according to an instruction from said recording control unit; a holding unit which holds management information for managing the recorded data; and a detection unit which detects a problem which occurs in processing performed from after the demodulating of the scrambled data by said first demodulation unit until the retrieving of the AV data, wherein, in the case where said detection unit detects the problem during recording of data by said recording unit, said recording control unit writes, into the management information, the detected problem and a time at which the problem occurred.

Accordingly, in the case where a problem is detected during the recording of AV data, the detected problem and the time at which the problem occurred can be managed on a per AV data basis.

Here, said recording control unit may control said recording unit to terminate the recording, after said detection unit detects the problem.

Accordingly, as AV data for which a problem has been detected is not recorded, unneeded recording can be prevented.

Furthermore, in the case where, after the recording by said recording unit is terminated when said detection unit detects the problem, said detection unit can no longer detect the problem, said recording control unit may control resumption of the recording by said recording unit, according to a predetermined condition.

Accordingly, the storing of data can be resumed depending on the time (duration) for which descrambling was not possible.

Furthermore, the digital broadcast recording apparatus may further include a media writing unit which stores, onto a writeable medium, the AV data recorded by said recording unit.

Here, said media writing unit may refer to the management information when the recorded AV data is to be stored onto the medium, and may not store the AV data onto the medium in the case where the problem occurred during the recording of the AV data to be stored.

Accordingly, it is possible to prevent the recording of AV data for which a problem was detected during the recording of data.

Furthermore, the digital broadcast recording apparatus may further include a notification unit which refers to the management information when the recorded AV data is to be stored onto the medium, and, in the case where the problem occurred during the recording of the AV data to be stored, notifies a user of the occurrence of the problem during the recording.

Accordingly, as defects such as when a problem is detected during the recording of the data being stored can be recognized, even without the user verifying the details of the AV data beforehand, it is possible to accurately judge whether or not the data should be stored onto the medium.

Here, the digital broadcast recording apparatus may further include an instruction obtainment unit which obtains, from the user, an instruction which is based on the notification by said notification unit, wherein said media writing unit may store the data onto the medium in the case where the instruction obtained by said instruction obtainment unit is a write instruction.

Accordingly, not only is it possible for data for which a problem is detected during data recording, to be stored onto media according to the instruction of the user, it is possible to prevent the recording of unneeded data onto the medium (especially in media that can only be written on once).

Moreover, aside from being realized as the aforementioned digital broadcast recording apparatus, the present invention can also be realized as a digital broadcast recording method having the characteristic units included in such digital broadcast recording apparatus as steps, and as a program which causes a computer to execute such steps. Furthermore, it goes without saying that such a program can be distributed via a recording medium such as a CD-ROM, and a transmission medium such as the Internet.

As described in the aforementioned manner, according to the digital broadcast recording apparatus in the present invention, the occurrence of a descrambling-not-possible situation during the recording of the data can be managed on a per data basis. Furthermore, in the case where a situation in which descrambling is not possible occurs during the recording of data, the continued recording of unneeded data can be prevented and it is possible to conserve resources used in the storage of data. Accordingly, the practical value of the present invention in today's setting, where digital broadcast recording apparatus for receiving and storing scrambled data are widely used, is extremely high.

#### FURTHER INFORMATION ABOUT TECHNICAL BACKGROUND TO THIS APPLICATION

The disclosure of Japanese Patent Application No. 2004-355430 filed on Dec. 8, 2004 including specification, drawings and claims is incorporated herein by reference in its entirety.

#### BRIEF DESCRIPTION OF THE DRAWINGS

These and other objects, advantages and features of the invention will become apparent from the following descrip-

tion thereof taken in conjunction with the accompanying drawings that illustrate a specific embodiment of the invention. In the Drawings:

FIG. 1 is a structure diagram showing the structure of the conventional program execution apparatus.

FIG. 2 is a structure diagram of the first embodiment of the cable television system according to the present invention;

FIG. 3 shows an example of the usage of the frequency bands used in communication between the head end and the terminal apparatus in the cable television system according to the present invention;

FIG. 4 shows an example of the usage of the frequency bands used in communication between the head end and the terminal apparatus in the cable television system according to the present invention;

FIG. 5 shows an example of the usage of the frequency bands used in communication between the head end and the terminal apparatus in the cable television system according to the present invention;

FIG. 6 is a structure diagram of the terminal apparatus in the cable television system according to the present invention;

FIG. 7 shows an example of the external appearance of the terminal apparatus in the cable television system according to the present invention;

FIG. 8 is a structure diagram showing the hardware structure of the POD according to the present invention;

FIG. 9 is a structure diagram showing the program structure stored by the POD according to the present invention;

FIG. 10 is a structure diagram of the packet defined in the MPEG Specification;

FIG. 11 shows an example of an MPEG-2 transport stream;

FIG. 12 shows an example of the external appearance in the case where the input unit is structured as a front panel;

FIG. 13 is a structure diagram showing the program structure stored by the terminal apparatus according to the present invention;

FIG. 14A shows an example of a screen display of the display according to the present invention, FIG. 14B shows an example of a screen display of the display according to the present invention;

FIG. 15A shows an example of a screen display of the display according to the present invention, FIG. 15B shows an example of a screen display of the display according to the present invention;

FIG. 16 shows an example of information stored by the secondary storage unit according to the present invention;

FIG. 17 shows an example of information stored by the primary storage unit according to the present invention;

FIG. 18 shows an example of the management table stored in the secondary storage unit according to the present invention;

FIG. 19 is a schematic diagram representing the details of the PAT defined by the MPEG-2 Specification, according to the present invention;

FIG. 20 is a schematic diagram representing the details of the PMT defined by the MPEG-2 Specification, according to the present invention;

FIG. 21 is a schematic diagram representing the details of the AIT defined by the OCAP Specification, according to the present invention;

FIG. 22 is a diagram showing an example of a downloaded file system, in the first embodiment;

FIG. 23 is a flowchart indicating the operation when a descrambling-not-possible situation occurs during recording, in the first embodiment;



## 5

FIG. 24 is a flowchart indicating the operation when a descrambling-not-possible situation occurs during recording, in the second embodiment;

FIG. 25 is a flowchart indicating the operation in writing, onto a writable medium, a program which is the subject of recording;

FIG. 26 shows an example of a screen display of the display according to the present invention;

FIG. 27 shows an example of a screen display of the display according to the present invention;

FIG. 28 shows an example of the management table stored in the secondary storage unit according to the present invention;

FIG. 29 shows an example of a screen display of the display according to the present invention;

FIG. 30 is a diagram describing the resumption of recording depending on the duration for which descrambling was not possible, in the second embodiment;

FIG. 31 is a diagram showing an example of problem information notified to the user, in the third embodiment;

FIG. 32 is a diagram showing an example a structural diagram of the program in the fourth embodiment;

FIG. 33 shows an example of management table in the fourth embodiment;

FIG. 34 shows an example of management table in the fourth embodiment;

FIG. 35 shows an example of management table in the fourth embodiment;

FIG. 36 is a flowchart showing an example of the recording resumption in the fourth embodiment;

FIG. 37 is a flowchart showing an example of the recording resumption in the fifth embodiment;

FIG. 38 is a diagram for explaining the resumption of recording depending on the duration for which descramble was not possible, in the fifth embodiment;

FIG. 39 is a diagram for explaining the resumption of recording depending on the duration for which descramble was not possible, in the fifth embodiment;

FIG. 40 is a diagram showing an example of the structural diagram of the program in the sixth embodiment;

FIG. 41 is a flowchart showing an example of the recording resumption in the sixth embodiment; and

FIG. 42 is a flowchart showing an example of the starting of recording upon re-activation, in the sixth embodiment.

#### DESCRIPTION OF THE PREFERRED EMBODIMENT(S)

The embodiments of the present invention are described, hereinafter, with reference to the diagrams.

##### First Embodiment

The embodiment of the cable television system in the present invention is described with reference to the diagrams. FIG. 2 is a block diagram representing the relationship of apparatuses making up a cable system. The cable system includes a head end 101, and three terminal apparatuses, namely a terminal apparatus A111, a terminal apparatus B112, and a terminal apparatus C113. In the present embodiment, three terminal apparatuses are connected to one head end. However, the present invention can be carried out even with an arbitrary number of terminal apparatuses being connected to the head end.

The head end 101 transmits, to plural terminal apparatuses, broadcast signals such as video, audio and data, and receives data transmitted from the terminal apparatuses. In order to

## 6

realize this, frequency bands are divided for use in data transmission between the head end 101, and the terminal apparatus A111, the terminal apparatus B112, and the terminal apparatus C113. FIG. 3 is a table showing an example of divided frequency bands. There are roughly two types of frequency bands: Out of Band (to be abbreviated as OOB) and In-Band. A frequency band of 5~130 MHz is allocated to OOB to be mainly used for data exchange between the head end 101, and the terminal apparatus A111, the terminal apparatus B112, and the terminal apparatus C113. A frequency band of 130 MHz~864 MHz is allocated to In-Band to be mainly used for broadcast channels including video and audio. QPSK is employed for OOB, whereas QAM64 is employed for In-Band as modulation techniques. A detailed description of modulation techniques is omitted here, since they are publicly known techniques which are less related to the present invention. FIG. 4 shows a more specific example of how the OOB frequency band is used. A frequency band of 70 MHz~74 MHz is used to transmit data from the head end 101. In this case, all of the terminal apparatus A111, the terminal apparatus B112, and the terminal apparatus C113 receive the same data from the head end 101. Meanwhile, a frequency band of 10.0 MHz~10.1 MHz is used to transmit data from the terminal apparatus A111 to the head end 101. A frequency band of 10.1 MHz~10.2 MHz is used to transmit data from the terminal apparatus B112 to the head end 101. A frequency band of 10.2 MHz~10.3 MHz is used to transmit data from the terminal apparatus C113 to the head end 101. Accordingly, data which is unique to each terminal apparatus can be transmitted to the head end 101 from the terminal apparatus A111, the terminal apparatus B112, and the terminal apparatus C113. FIG. 5 shows an example use of the In-Band frequency band. Frequency bands of 150~156 MHz and 156~162 MHz are allocated respectively to a television channel 1 and a television channel 2, and the subsequent frequencies are allocated to television channels at 6 MHz intervals. 310 MHz and the subsequent frequencies are allocated to radio channels at 1 MHz intervals. Each of the above channels may be used either for analog broadcasting or digital broadcasting. In the case of digital broadcasting, data is transmitted in the transport packet format compliant with the MPEG-2 specification, in which case data intended for various data broadcasting systems can be transmitted, in addition to audio and video data.

The head end 101 is equipped with a QPSK modulation unit, a QAM modulation unit, and the like in order to transmit suitable broadcast signals to the respective frequency ranges. Moreover, the head end 101 is equipped with a QPSK demodulation unit for receiving data from the terminal apparatuses. Also, the head end 101 is assumed to be further equipped with various devices related to the above modulation units and demodulation unit. However, detailed descriptions for these are omitted here, since the present invention is mainly related to the terminal apparatuses.

The terminal apparatus A111, the terminal apparatus B112, and the terminal apparatus C113 receive and reproduce broadcast signals transmitted from the head end 101. Furthermore, the terminal apparatus A111, the terminal apparatus B112, and the terminal apparatus C113 transmit data unique to each terminal apparatus to the head end 101. In the present embodiment, these three terminal apparatuses have the same configuration.

FIG. 6 is a block diagram showing a hardware configuration of the terminal apparatus (digital broadcast recording apparatus). A terminal apparatus 500 includes a QAM demodulation unit 501, a QPSK demodulation unit 502, a QPSK modulation unit 503, a TS decoder 505, an audio decoder 506, an audio output unit 507, a video decoder 508, a

video output unit **509**, a secondary storage unit **510**, a primary storage unit **511**, a ROM **512**, an input unit **513**, a CPU **514**, a descrambling judgment unit **515**, and a media writing unit **516**. Furthermore, a POD **504** can be attached to/detached from the terminal apparatus **500**.

FIG. 7 shows a digital broadcast receiving terminal and a television which are an example of the external appearance of the terminal apparatus **500**.

A terminal apparatus **601** contains within its housing, all constituent elements of the terminal apparatus **500** except for the POD **504**.

A signal input terminal **602** is connected with a cable line in order to perform transmission/reception of signals to and from the head end **101**. In addition, the signal input terminal **602** is connected with the QAM demodulation unit **501**, the QPSK demodulation unit **502**, and the QPSK modulation unit **503** in FIG. 6.

A POD card **603** is a POD card corresponding to the POD **504** in FIG. 6. The POD **504** is embodied independently of the terminal apparatus **500** and can be attached to/detached from the terminal apparatus **500**, as in the case of the POD card **603** in FIG. 7. A detailed description of the POD **504** is given later.

An insertion slot **604** is an insertion slot into which the POD card **603** is inserted.

A front panel **605** is composed of plural buttons, and corresponds to the input unit **513** in FIG. 6. One button in the front panel **605** is an eject button which is pressed when ejecting the POD card **603**. By pressing the eject button, the POD **603** can be ejected.

A video cable **606** is a cable which conveys the video output from the terminal apparatus **601** to a television **608**. The video cable **606** is connected to the video output unit **509** in FIG. 6. The audio cable **607** is a cable which conveys the audio output from the terminal apparatus **601** to a television **608**. The audio cable **607** is connected to the audio output unit **507** in FIG. 6.

The television **608** includes a display **609** and a speaker **610** within its housing, and outputs via the display **609** and the speaker **610**, respectively, the video output and audio output from the terminal apparatus **601** which are received as data through the video cable **606** and the audio cable **607**.

Referring to FIG. 6, the QAM demodulation unit **501** demodulates a signal which has been QAM-modulated in and transmitted from the head end **101**, according to tuning information that includes a frequency specified by the CPU **514**, and passes the result to the POD **504** or the TS decoder **505** which is designated by the CPU.

The QPSK demodulation unit **502** demodulates a signal which has been QPSK-modulated in and transmitted from the head end **101**, according to tuning information that includes a frequency specified by the CPU **514**, and passes the result to the POD **504**.

The QPSK modulation unit **503** QPSK-demodulates the signal passed from the POD **504**, according to demodulation information that includes a frequency specified by the CPU **514**, and transmits the result to the head end **101**.

As shown in FIG. 7, the POD **504** is detachable from the main body of the terminal apparatus **500**. The definition of the connection interface between the main body of the terminal **500** and the POD **504** is given in the OpenCable (™) HOST-POD Interface Specification (OC-SP-HOSTPOD-IF-I12-030210) and specifications referred to by such specification. Here, a detailed description is omitted, and a description is given only for portions relevant to the present invention.

FIG. 8 is a block diagram showing an internal configuration of the POD **504**. The POD **504** is made up of a first descrambler unit **701**, a second descrambler unit **702**, a

scrambler unit **703**, a primary storage unit **704**, a secondary storage unit **705**, and a CPU **706**.

The first descrambler unit **701**, under instruction from the CPU **706**, receives a scrambled signal from the QAM demodulation unit **501** of the terminal apparatus **500** and descrambles such signal. Then, the first descrambler unit **701** transmits the descrambled signal to the TS decoder **505** and the secondary storage unit **510** of the terminal apparatus **500**. Information required for decoding such as a key is provided by the CPU **706** as necessary. More specifically, the head end **101** broadcasts several pay channels, and when the user purchases the right to view these pay channels, the first descrambler unit **701** receives required information such as a key from the CPU **706** and performs descrambling, and the user is able to view these pay channels. When required information such as a key is not provided, the first descrambler unit **701** passes the received signal directly to the TS decoder **505** and the secondary storage unit **510** without performing descrambling.

The second descrambler unit **702**, under instruction from the CPU **706**, receives a scrambled signal from the QPSK demodulation unit **502** of the terminal apparatus **500** and descrambles such signal. Then, the second descrambler unit **702** passes the descrambled data to the CPU **706**.

The scrambler unit **703**, under instruction from the CPU **706**, scrambles the data received from the CPU **706** and sends the result to the QPSK modulation unit **503** of the terminal apparatus **500**.

The primary storage unit **704**, specifically made up of a primary memory such as a RAM, is utilized for storing data temporarily when the CPU **706** performs processing.

The secondary storage unit **705**, specifically made up of a secondary storage memory such as a flash ROM, is utilized for storing a program to be executed by the CPU **706** as well as for storing data which should not be deleted even when the power is turned off.

The CPU **706** sends a descrambling-not-possible message to the descrambling judgment unit **515** in FIG. 6, when descrambling in the first descrambler unit **701** or the second descrambler unit **702** becomes not possible. More specifically, the case where keys (a first key and a second key) stored in the POD **504** become invalid due to the expiration of the user's contract term, and the case where a descrambling key (a fourth key: retrieved from data included in the Out Of Band, using the QPSK demodulation unit **502**, and stored within the POD **504**) used in descrambling and sent from the head end cannot be acquired due to communication problems such as communication noise, and descrambling in the first descrambler unit **701** or the second descrambler unit **702** is not carried out. In addition, the CPU **706** executes the program stored by the secondary storage unit **705**. The program is made up of plural subprograms. FIG. 9 shows an example of the program stored by the secondary storage unit **705**. In FIG. 9, a program **800** is made up of plural subprograms including a main program **801**, an initialization subprogram **802**, a network subprogram **803**, a reproduction subprogram **804**, and a PPV subprogram **805**.

Here, PPV, which is an abbreviation of Pay Per View, refers to a service that allows the user to view a certain program such as a movie, on a charge basis. When the user enters his personal identification number, the purchase of the right to view the program is notified to the head end **101**, scrambling is cancelled, and such program can be viewed by the user. With this viewing, the user is required to pay the purchase price at a later date.

The main program **801**, which is the subprogram activated first by the CPU **706** when the power is turned on, controls the other subprograms.

The initialization subprogram **802**, which is activated by the main program **801** when the power is turned on, performs information exchange with the terminal apparatus **500** and performs initialization. The details of this initialization is defined in detail in the OpenCable (™) HOST-POD Interface Specification (OC-SP-HOSTPOD-IF-I12-030210) and in specifications referred to by such specification. Furthermore, the initialization subprogram **802** also performs initialization not defined in these specifications. Here, a part of such initialization is introduced. When the power is turned on, the initialization subprogram **802** notifies the QPSK demodulation unit **502** of a first frequency stored in the secondary storage unit **705** via the CPU **514** of the terminal apparatus **500**. The QPSK demodulation unit **502** performs tuning using the provided first frequency, and transmits the resulting signal to the secondary scrambler unit **702**. Moreover, the initialization subprogram **802** provides the secondary descrambler unit **702** with descrambling information such as a first key stored in the secondary storage unit **705**. As a result, the secondary descrambler unit **702** performs descrambling and passes the result to the CPU **706** executing the initialization subprogram **802**. As such, the initialization subprogram **802** can receive the information. In the present embodiment, the initialization subprogram **802** receives information via the network subprogram **803**. A detailed description on this is given later.

Furthermore, the initialization subprogram **802** notifies the QPSK modulation unit **503** of a second frequency stored in the secondary storage unit **705** via the CPU **514** of the terminal apparatus **500**. The initialization subprogram **802** provides the scrambler unit **703** with scrambling information (for example, an algorithm, program or the like, necessary for scrambling) stored in the secondary storage unit **705**. When the initialization subprogram **802** provides, via the network subprogram **803**, the scrambler unit **703** with information required to be sent, the scrambler unit **703** scrambles the data using the provided scrambling information, and provides the scrambled data to the QPSK modulation unit **503**. The QPSK modulation unit **503** modulates the scrambled information which it received, and sends the modulated information to the head end **101**.

As a result, it becomes possible for the initialization subprogram **802** to carry out a two-way communication with the head end **101** via the terminal apparatus **500**, the secondary descrambler unit **702**, the scrambler unit **703**, and the network subprogram **803**.

The network subprogram **803**, which is used by plural subprograms such as the main program **801** and the initialization subprogram **802**, is a subprogram intended for carrying out a two-way communication with the head end **101**. More specifically, the network subprogram **803** behaves as if other subprograms using the network subprogram **803** were carrying out a two-way communication with the head end **101** in accordance with TCP/IP. A detailed description of TCP/IP is omitted here, since it is a publicly known technique for specifying the protocols to be used when exchanging information between plural terminals. When activated by the initialization subprogram **802** at power-on time, the network subprogram **803** notifies, via the terminal apparatus **500**, the head end **101** of an MAC address (an abbreviation of Media Access Control address) which is an identifier for identifying the POD **504** and which is stored in the secondary storage unit **705** beforehand, so as to request for the obtainment of an IP address. The head end **101** notifies the POD **504** of the IP

address via the terminal apparatus **500**, and the network subprogram **803** stores such IP address in the primary storage unit **704**. From here on, the head end **101** and the POD **504** communicate with each other using such IP address as the identifier of the POD **504**.

The reproduction subprogram **804** provides the first descrambler unit **701** with descrambling information such as a second key stored in the secondary storage unit **705** as well as descrambling information such as a third key provided by the terminal apparatus **500**, so as to allow descrambling to be performed. Furthermore, the reproduction subprogram **804** receives, via the network subprogram **803**, information indicating that the signal inputted in the first descrambler unit **701** is a PPV channel. On the notification that the signal is a PPV channel, the reproduction subprogram **804** activates the PPV subprogram **805**.

When activated, the PPV subprogram **805** displays, on the television **608** via the terminal apparatus **500**, a message that prompts the user to purchase the program, and accepts an input from the user. More specifically, when information intended to be displayed on the screen is sent to the CPU **514** of the terminal apparatus **500**, a program running on the CPU **514** of the terminal apparatus **500** sends video data for displaying the message, to the video output unit **509** of the terminal apparatus **500**, and displays the message on the display **609** of the television **608**. Then, when the user enters the personal identification number via the input unit **513** of the terminal apparatus **500**, the CPU **514** of the terminal apparatus **500** accepts it, and sends it to the PPV subprogram **805** running on the CPU **706** of the POD **504**. The PPV subprogram **805** sends, to the head end **101**, the accepted personal identification number via the network subprogram **803**. When such personal identification number is valid, the head end **101** notifies, via the network subprogram **803**, the PPV subprogram **805** of descrambling information required for descrambling such as a fourth key (in addition to the fourth key, it is also possible to include a descrambling algorithm or a descrambling program which use the fourth key). The PPV subprogram **805** provides the first descrambler unit **701** with the accepted descrambling information such as the fourth key, and then the first descrambler unit **701** descrambles the signal being inputted.

Referring to FIG. 6, the TS decoder **505** performs filtering on the signal accepted from the POD **504**, and passes necessary data to the audio decoder **506**, the video decoder **508**, and the CPU **514**. Here, the signal sent from the POD **504** is an MPEG-2 transport stream. A detailed description about an MPEG-2 transport stream is given in the MPEG specification ISO/IEC138181-1, and therefore detailed description is omitted in the present embodiment. An MPEG-2 transport stream is composed of plural fixed-length packets, and a packet ID is assigned to each packet. FIG. 10 is a diagram showing the structure of a packet. **900** is a packet structured by 188 bytes having fixed length. The top four bytes is a header **901** storing information for identifying the packet, and the remaining 184 bytes is a payload **902** which contains the information to be transmitted. **903** shows the breakdown of the header **901**. A packet ID is included in the 13 bits of the twelfth to twenty-fourth bits from the top. FIG. 11 is a schematic diagram illustrating plural packet strings to be transmitted. A packet **1001** carries a packet ID "1" in its header and includes the first information of video A in its payload. A packet **1002** carries a packet ID "2" in its header and includes the first information of audio A in its payload. A packet **1003** carries a packet ID "3" in its header and includes the first information of audio B in its payload.

## 11

A packet 1004 carries the packet ID "1" in its header and includes the second information of the video A in its payload, and is the continuation of the packet 1001. Similarly, packets 1005, 1026, and 1027 carry follow-on data of the other packets. By concatenating the contents of the payloads of packets with the same packet IDs in the above manner, it is possible to reproduce a continuing video and audio.

Referring to FIG. 11, when the CPU 514 indicates, to the TS decoder 505, the packet ID "1" as well as "the video decoder 508" as an output destination, the TS decoder 505 extracts packets with the packet ID "1" from the MPEG-2 transport stream received from the POD 504, and passes them to the video decoder 508. In FIG. 11, therefore, only the video data is passed over to the video decoder 508. At the same time, when the CPU 514 indicates, to the TS decoder 505, the packet ID "2" as well as "the audio decoder 506", the TS decoder 505 extracts packets with the packet ID "2" from the MPEG-2 transport stream received from the POD 504, and passes them to the audio decoder 506. In FIG. 11, only the audio data is passed over to the video decoder 508.

This process of extracting only necessary packets according to the packet IDs corresponds to the filtering performed by the TS decoder 505. The TS decoder 505 is capable of performing more than one filtering simultaneously, at the instruction of the CPU 514.

Referring to FIG. 6, the audio decoder 506 concatenates audio data embedded in the packets in the MPEG-2 transport stream provided by the TS decoder 505, performs digital-to-analog conversion on the concatenated data, and outputs the result to the audio output unit 507.

The audio output unit 507 outputs the signal provided by the audio decoder 506.

The video decoder 508 concatenates video data embedded in the packets in the MPEG-2 transport stream provided by the TS decoder 505, performs digital-to-analog conversion on the concatenated data, and outputs the result to the video output unit 509.

The video output unit 509 outputs the signal provided by the video decoder 508.

The secondary storage unit 510 is a re-writable storage unit, and is specifically made up of a flash memory or a hard disk and the like, stores and deletes data and programs specified by the CPU 514. Stored data and programs are referred to by the CPU 514. The stored data and programs are kept in storage even when power to the terminal apparatus 500 is cut off.

The primary storage unit 511, specifically made up of a RAM and the like, temporarily stores and deletes data and programs specified by the CPU 514. Stored data and programs are referred to by the CPU 514. The stored data and programs are deleted when power to the terminal apparatus 500 is cut off.

The ROM 512 is a read-only memory device, specifically made up of are a ROM, a CD-ROM, or a DVD, and the like. The ROM 512 stores a program to be executed by the CPU 514.

The input unit 513, specifically made up of a front panel or remote control, accepts an input from the user. FIG. 12 shows an example of the input unit 513 in the case where it is configured in the form of a front panel. 1100 is a front panel, which corresponds to the front panel unit 603 shown in FIG. 7. Such front panel 1100 includes nine buttons, namely, an up-cursor button 1101, a down-cursor button 1102, a left-cursor button 1103, a right-cursor button 1104, an OK button 1105, a cancel button 1106, an EPG button 1107, a record

## 12

button 1108, and a POD eject button 1109. When the user presses down a button, the identifier of such pressed button is notified to the CPU 514.

The CPU 514 executes the program stored in the ROM 512. Following the instructions from such program to be executed, the CPU 514 controls the QAM demodulation unit 501, the QPSK demodulation unit 502, the QPSK modulation unit 503, the POD 504, the TS decoder 505, the video output unit 509, the secondary storage unit 510, the primary storage unit 511, the ROM 512, the descrambling judgment unit 515, and the media writing unit 516.

The descrambling judgment unit 515 is an apparatus or a program for judging whether or not conditions for descrambling a channel designated by the CPU are satisfied. More specifically, it judges whether or not the POD 504 is physically inserted into the terminal 500, and judges the conditions for whether or not descrambling is possible according to the descrambling-not-possible message received from the CPU 706 of the POD 504.

The media writing unit 516 is a drive for re-writable media, which receives a write instruction from the CPU 514, and writes data stored in the secondary storage unit 510 onto a medium. More specifically, it is a drive for a flash memory such as a DVD-RAM, a DVD-R, a DVD-RW+, a DVD-RW-, a Blue-ray Disc, a CR-R, a USB flash memory, and a SD memory card.

Furthermore, although in FIG. 6, the media writing unit 516 is provided inside the terminal apparatus 500, the media writing unit 516 may also be provided outside the terminal apparatus 500 and connected to the terminal apparatus 500 via wiring, and the like. In this case, aside from the above-mentioned media located outside the terminal apparatus 500, it is possible for the media writing unit 516 to write the data stored in the secondary storage unit 510, into a hard disk which can be written into by the media writing unit 516.

FIG. 13 is a diagram showing an example of the structure of the program stored in the ROM 512 and executed by the CPU 514.

A program 1200 is made up of plural subprograms, and more specifically, is made up of an OS 1201, an EPG 1202, a Java (trademark) VM 1203, a service manager 1204, and a Java library 1205.

The OS 1201 is a subprogram activated by the CPU 514 when power to the terminal apparatus 500 is turned on. The OS 1201 stands for operating system, an example of which is Linux and the like. The OS 1201 is a generic name for publicly known technology made up of a kernel 1201a for executing a subprogram in parallel with another subprogram and of a library 1201b, and therefore a detailed description is omitted. In the present embodiment, the kernel 1201a of the OS 1201 executes the EPG 1202 and the Java VM 1203 as subprograms. Meanwhile, the library 1201b provides these subprograms with plural functions (for example, mathematical functions) required for controlling the constituent elements of the terminal apparatus 500.

As an example of such functions, tuning, recording, media writing, and time obtainment are described. In the tuning function, tuning information including a frequency is received from another subprogram and then passed over to the QAM demodulation unit 501. Accordingly, it is possible for the QAM demodulation unit 501 to perform demodulation based on the provided tuning information, and pass the demodulated data to the POD 504 and the TS decoder 505. As a result, the other subprograms can control the QAM demodulation unit via the library 1201b.

In the recording function, a record instruction or a terminate-recording instruction is received from another subpro-

## 13

gram and passed on to the CPU 514. In the case where the program which is the subject of recording (hereinafter referred to as a recording-subject-program) is not scrambled, the CPU 514 receiving the record instruction stores the data demodulated by the QAM demodulation unit 501 into the secondary storage unit 510. In the case where the recording-subject-program is scrambled, the data demodulated by the POD 504 is stored in the secondary storage unit 510. As a result, another subprogram can hold a designated program (television program) in the secondary storage unit, through the library 1201b. Upon receiving the terminate-recording instruction, the CPU 514 terminates the above-mentioned storing.

In the media writing function, recording information and writing information stored in the secondary storage unit 510 are received from another subprogram, and the recording-subject-program stored in the secondary storage unit 510 is sent to the media writing unit 516 for writing into a medium. As a result, it is possible for another subprogram to control the media writing unit 516, through the library 1201b, and write the recording-subject-program stored in the secondary storage unit 510 into a medium inserted in the media writing unit 516.

The time obtainment function is a function for obtaining the present time.

The EPG 1202 is made up of a program display unit 1202a for displaying a list of programs to the user as well as for accepting an input from the user, a reproduction unit 1202b for selecting channels, and a recording unit 1202c for recording. Here, EPG is an abbreviation of Electronic Program Guide. The EPG 1202 gets activated when power to the terminal apparatus 500 is turned on. In the activated EPG 1202, the program display unit 1202a waits for an input from the user via the input unit 513 of the terminal apparatus 500. Here, in the case where the input unit 513 takes the form of the front panel illustrated in FIG. 12, when the user presses down the EPG button 1107 on the input unit 513, the CPU 514 is notified of the identifier of such EPG button. The program display unit 1202a of the EPG 1202, which is a subprogram running on the CPU 514, accepts this identifier and displays program information on the display 609 via the video output unit 509. FIG. 14A and FIG. 14B show examples of a program table displayed on the display 609. Referring to FIG. 14A, the program information is displayed on the display 609 in a grid pattern. A column 1301 describes time information. A column 1302 describes a channel name "Channel 1" and programs to be broadcast during time periods corresponding to the respective times described in the column 1301. It is shown that a program "News 9" is broadcast from 9:00 to 10:30, and "Cinema AAA" is broadcast from 10:30 to 12:00 on "Channel 1". A column 1303 describes a channel name "Channel 2" and programs to be broadcast during time periods corresponding to the respective times described in the column 1301, as in the case of the column 1302. A program "Cinema BBB" is broadcast from 9:00 to 11:00, and "News 11" is broadcast from 11:00 to 12:00. 1330 is a cursor. The cursor 1330 moves at the press of the left-cursor 1103 or the right-cursor 1104 on the front panel 1100. When the right-cursor 1104 is pressed down in the state illustrated in FIG. 14A, the cursor 1330 moves towards the right as shown in FIG. 14B. Meanwhile, when the left-cursor 1103 is pressed down in the state illustrated in FIG. 14B, the cursor 1330 moves towards the left as shown in FIG. 14A.

When the OK button 1105 on the front panel 1100 is pressed down in the state shown in FIG. 14A, the program display unit 1202a notifies the reproduction unit 1202b of the identifier of "Channel 1". Meanwhile, when the OK button

## 14

1105 on the front panel 1100 is pressed down in the state shown in FIG. 14B, the program display unit 1202a notifies the reproduction unit 1202b of the identifier of "Channel 2". In addition, when the user presses down the record button 1108 on the input unit 513, the CPU 514 is notified of the identifier of the record button. The program display unit 1202a of the EPG 1202, which is a subprogram running on the CPU 514, accepts this identifier and displays program information on the display 609. FIG. 15A and FIG. 15B show examples of a program table displayed on the display 609. Referring to FIG. 15A, the program information is displayed on the display 609 in a grid pattern. A column 1401 describes time information. A column 1402 describes a channel name "Channel 1" and programs to be broadcast during time periods corresponding to the respective times described in the column 1401. It is shown that a program "News 9" is broadcast from 9:00 to 10:30, and "Cinema AAA" is broadcast from 10:30 to 12:00 on "Channel 1". A column 1403 describes a channel name "Channel 2" and programs to be broadcast during time periods corresponding to the respective times described in the column 1401, as in the case of the column 1402. A program "Cinema BBB" is broadcast from 9:00 to 11:00, and "News 11" is broadcast from 11:00 to 12:00. 1330 is a focus frame. The focus frame 1430 moves at the press of the up-cursor button 1101, the down-cursor button 1102, the left-cursor 1103 or the right-cursor 1104 on the front panel 1100. When the right-cursor 1104 is pressed down in the state illustrated in FIG. 15A, the focus frame 1430 moves towards the right as shown in FIG. 15B. Meanwhile, when the left-cursor 1103 is pressed down in the state illustrated in FIG. 15B, the focus frame 1330 moves towards the left as shown in FIG. 15A.

When the OK button 1105 on the front panel 1100 is pressed down in the state shown in FIG. 15A, the program display unit 1202a notifies the record unit 1202c of the identifier of "Channel 1" as well as the start time and end time for "News 9". Meanwhile, when the OK button 1105 on the front panel 1100 is pressed down in the state shown in FIG. 14B, the program display unit 1202a notifies the reproduction unit 1202b of the identifier of "Channel 2" as well as the start time and end time for "Cinema BBB".

Furthermore, the program display unit 1202a periodically stores program information to be displayed from the head end 101 into the primary storage unit 511 via the POD 504. Generally, it takes time to obtain program information from the head end. However, it becomes possible to quickly display a program table by displaying the program information that is pre-stored in the primary storage unit 511 at the press of the EPG button 1107 of the input unit 513.

The reproduction unit 1202b reproduces the channel using the received identifier of the channel. The relationship between channel identifiers and channels is pre-stored by the secondary storage unit 510 as channel information. FIG. 16 shows an example of the channel information stored in the secondary storage unit 510. The channel information is stored in tabular form. A column 1501 describes the identifiers of channels. A column 1502 describes channel names. A column 1503 describes tuning information. Here, the tuning information is represented by values to be provided to the QAM demodulation unit 501 such as frequency, transmission rate, and coding ratio. A column 1504 describes program numbers. Program numbers are numbers used to identify PMTs defined by the MPEG-2 standard. A description about PMT is given later. Each of lines 1511~1514 indicates a set of the identifier, channel name, and tuning information of each channel. The line 1511 describes a set that includes "1" as an identifier, "Channel 1" as a channel name, a frequency of "312 MHz" as

## 15

tuning information, and "101" as a program number. The reproduction unit 1202b passes the identifier and the reproduce instruction of the received channel to the service manager in order to reproduce the channel.

Moreover, when the user presses down the up-cursor 1101 and the down-cursor 1102 on the front panel 1100 while the reproduction is taking place, the reproduction unit 1202b receives a notification about such press by the user from the input unit 513 via the CPU 514, and switches the channel being reproduced to another one. First, the reproduction unit 1202b stores, in the primary storage unit 511, the identifier of the channel that is currently reproduced. FIGS. 17A, B and C show example identifiers of channels stored in the primary storage unit 511. FIG. 17A shows that an identifier "3" is stored, and it is shown by referring to FIG. 16 that a channel with the channel name "TV 3" is being reproduced. When the user presses down the up-cursor 1101 in a state illustrated in FIG. 17A, the reproduction unit 1202b refers to the channel information shown in FIG. 16, and passes the identifier "2" of a channel with the channel name of "Channel 2" to the service manager in order to newly reproduce a channel with the channel name of "Channel 2", which is the previous channel in the table. At the same time, the reproduction unit 1202b rewrites the identifier into the channel identifier "2" stored in the primary storage unit 511. FIG. 17B shows such rewritten channel identifier. Meanwhile, when the user presses down the down-cursor 1102 in the state illustrated in FIG. 17A, the reproduction unit 1202b refers to the channel information shown in FIG. 16, and passes the identifier "4" of a channel with the channel name of "TV Japan" to the service manager in order to newly reproduce a channel with the channel name of "TV Japan", which is the next channel in the table. At the same time, the reproduction unit 1202b rewrites the identifier into the channel identifier "4" stored in the primary storage unit 511. FIG. 17c shows such rewritten channel identifier.

The recording unit 1202c stores the received channel identifier, the start time and end time, into the secondary storage unit 510, as management information regarding recording data. The management information regarding recording data is stored, for example, in table form. FIGS. 18A and 18B are examples of management tables stored in the secondary storage unit 510. A column 1701 describes the recording data identifier (recording number) of recording data. A column 1702 describes channel identifiers. These channel identifiers correspond to the channel identifiers in column 1501 in FIG. 16. A column 1703 defines the start time for recording, and indicates the year, month, day, and time for the start of the recording. A column 1704 defines the end time for the recording, and indicates the year, month, day, and time for the end of the recording. A column 1705 defines values which indicate the recording status. In the present embodiment, a value of "0" is carried for pre-recording, "1" for currently-recording, and "2" for recording ended. A column 1706 describes values which indicate whether or not a program to be recorded is a scrambled broadcast. In the present embodiment, a value of "1" is carried in the case of a scrambled broadcast, and "2" for a non-scrambled broadcast. The recording unit 1202c obtains information on whether or not a program to be recorded is a scrambled broadcast via the library 1201b. A column 1707 describes values indicating whether or not a descrambling-not-possible situation was present during the recording of the scrambled broadcast. In the present embodiment, "1" is carried when present, and "2" when not present. Each of lines 1708 and 1709 describes management data regarding respective recording data, and indicates the set of the recording data identifier, channel identifier, recording start time, recording end time, execution status, the value indicating whether or not

## 16

a program is scrambled or not scrambled, and the value indicating whether or not a descrambling-not-possible situation has occurred.

Furthermore, when the current time reaches the start time in the recording data, the recording unit 1202c rewrites, to "1", the execution status of the management information corresponding to such recording data in the management table, and passes on the recording data identifier and the record instruction to the service manager 1204. For example, referring to FIG. 18A, in the case where the current time is 2004/3/10 11:00, the execution status in line 1709 is rewritten from "0" to "1" as the recording start time in line 1709 has been reached. FIG. 18B shows the recording data after rewriting. The execution status in line 1709 is rewritten as 1. Next, the recording unit 1202c passes on, to the service manager 1204, the recording data identifier and the record instruction of line 1709 which is recording data with a recording start time that has been reached.

The Java VM 1203 is a Java virtual machine that sequentially analyzes and executes programs written in the Java (™) language. Programs written in the Java language are compiled into intermediate codes known as byte codes which do not depend on hardware. The Java virtual machine is an interpreter that executes such byte codes. Some of the Java virtual machines translate the byte codes into an executable form which can be interpreted by the CPU 514 and pass the resultant to the CPU 514, which executes it. The Java VM 1203 gets activated, with a Java program to be executed being specified by the kernel 1201a. In the present embodiment, the kernel 1201a specifies the service manager 1204 as a Java program to be executed. A detailed commentary on the Java language is given in many books that include "Java Language Specification" (ISBN 0-201-63451-1). Therefore, a detailed description about it is omitted here. Also, a detailed commentary on the operation of the Java VM itself is given in many books that include "Java Virtual Machine Specification" (ISBN 0-201-63451-X). Therefore, a detailed description about it is omitted here.

The service manager 1204, which is a Java program written in the Java language, is executed by the Java VM 1203 sequentially. It is possible for the service manager 1204 to call and to be called by another subprogram not written in the Java language through the JNI (Java Native Interface). A commentary on the JNI is given in many books that include "Java Native Interface". Therefore, a detailed description about it is omitted here.

The service manager 1204 accepts the identifier of the channel from the reproduction unit 1202b through the JNI.

Upon accepting the identifier of the channel and the reproduce instruction from the reproduction unit 1202b, the service manager 1204 passes the identifier of the channel to a Tuner 1205c in the Java library 1205 so as to request for tuning. The Tuner 1205c refers to the channel information stored in the secondary storage unit 510 to obtain the tuning information. Assuming that the service manager 1204 passes the identifier "2" of the channel to the Tuner 1205c, the Tuner 1205c refers to the column 1512 shown in FIG. 16, and obtains the tuning information "156 MHz," corresponding to the channel. The Tuner 1205c passes the tuning information to the QAM demodulation unit 501 via the library 1201b of the OS 1201. The QAM demodulation unit 501 demodulates the signal sent from the head end 101 according to the tuning information given to the QAM demodulation unit 501. The resulting signal is passed by the QAM demodulation unit 501 to the POD 504 when the demodulated channel is a scrambled broadcast, and to the TS decoder 505 when it is not a scrambled program. Next, the service manager 1204 requests a CA 1205b inside

the Java library **1205** to perform descrambling. The CA **1205d** provides the POD **504** with information required for descrambling through the library **1201b** in the OS **1201**. On the basis of such provided information, the POD **504** descrambles the signal provided by the QAM demodulation unit **501**, and passes the resulting signal to the TS decoder **505**.

Next, the service manager **1204** provides a JMF **1205a** inside the Java library **1205** with the identifier of the channel, so as to request for the reproduction of the video and audio.

First, the JMF **1205a** obtains, from a PAT and a PMT, packet IDs used to specify the video and audio to be reproduced. PAT and PMT are tables defined by the MPEG-2 standard that show the program line-up included in an MPEG-2 transport stream. PAT and PMT are carried in the payloads in packets included in an MPEG-2 transport stream, together with audio and video. Refer to the specification for a detailed description of PAT and PMT. Here, only an overview of PAT and PMT is given. PAT, which is an abbreviation of Program Association Table, is carried in packets with the packet ID "0". In order to obtain the PAT, the JMF **1205a** indicates, to the TS decoder **505**, the packet ID "0" and the CPU **514** through the library **1201b** of the OS **1201**. Then, the TS decoder **505** performs filtering based on the packet ID "0", and passes the resultant to the CPU **514**. Accordingly, the JMF **1205a** can collect the PAT packets. FIG. **19** illustrates a table that schematically shows an example of the collected PAT information. A column **1801** describes program numbers. A column **1802** describes packet IDs. The packet IDs shown in the column **1802** are used to obtain the PAT. Each of lines **1811~1813** is a pair of the program number of a channel and a packet ID corresponding to it. Here, three channels are defined. The line **1811** defines a pair of the program number "101" and the packet ID "501". Assuming that the channel identifier provided to the JMF **1205a** is "2", the JMF **1205a** refers to the column **1512** in FIG. **16**, so as to obtain the program number "102" corresponding to such channel identifier, and then refers to the column **1812** in the PAT shown in FIG. **19**, so as to obtain the packet ID "502" corresponding to the program number "102". PMT, which is an abbreviation of Program Map Table, is carried in packets with the packet IDs specified in the PAT. In order to obtain the PMT, the JMF **1205a** indicates, to the TS decoder **505**, a packet ID and the CPU **514** through the library **1201b** of the OS **1201**. Here, a packet ID to be specified is "502". Then, the TS decoder **505** performs filtering based on the packet ID "502", and passes the resultant to the CPU **514**. Accordingly, the JMF **1205a** can collect the PMT packets. FIG. **20** illustrates a table that schematically shows an example of the collected PMT information. A column **1901** describes stream types. A column **1902** describes packet IDs. Information specified in the respective stream types is carried in the payloads of packets with the packet IDs specified in the column **1902**. A column **1903** describes additional information. Each of columns **1911~1914** is a pair of a packet ID and the type of information being transmitted, which is known as an elementary stream. The column **1911**, which is a pair of the stream type "audio" and the packet ID "5011", indicates that audio data is stored in the payload of the packet with the packet ID "5011". The JMF **1205a** obtains, from the PMT, the packet IDs of the video and audio to be reproduced. Referring to FIG. **20**, the JMF **1205a** obtains the audio packet ID "5011" from the line **1911**, and the video packet ID "5012" from the line **1912**.

Then, the JMF **1205a** provides the TS decoder **505** with pairs of the obtained audio packet ID and the audio decoder **506** as an output destination as well as the video packet ID and the video decoder **508** as an output destination, via the library

**1201b** of the OS **1201**. The TS decoder **505** performs filtering based on such provided packet IDs and the output destinations. Here, the packet with the packet ID "5011" is passed to the audio decoder **506** and the packet with the packet ID "5012" is passed to the video decoder **508**. The audio decoder **506** performs digital-to-analog conversion on the provided packet, and outputs the result to the audio output unit **507**. The video decoder **508** performs digital-to-analog conversion on the provided packet, and outputs the video to the video output unit **509**.

Finally, the service manager **1204** provides the channel identifier to an AM **1205b** in the Java library **1205**, so as to request for data broadcast reproduction. Here, data broadcast reproduction means to extract a Java program included in the MPEG-2 transport stream and cause the Java VM **1203** to execute it. As a technique for embedding a Java program into an MPEG-2 transport stream, a method known as DSMCC, which is described in the MPEG specification ISO/IEC138181-6, is used. A detailed explanation of DSMCC is omitted here. DSMCC specification defines a method of encoding a file system comprised of directories and files used by a computer, in packets within an MPEG-2 transport stream. Information about the Java program to be executed is carried in packets in the MPEG-2 transport stream in the form of AIT. AIT is an abbreviation of Application Information Table whose definition is given in the tenth chapter of the DVB-MHP standard (formally known as ETSI TS 101 812 DVB-MHP specification V1.0.2).

Furthermore, upon accepting the identifier of the recording data and the record instruction from the recording unit **1202c**, the service manager **1204** searches for a recording identifier that matches the accepted recording identifier from column **1701** of the recording data stored in the secondary storage unit **510**, and passes the channel identifier in the same line to the Tuner **1205c** in the Java library **1205** so as to request for tuning. The Tuner **1205c** refers to the channel information stored in the secondary storage unit **510** to obtain the tuning information. Now, assuming that the recording unit **1202c** passes the recording data identifier "2" and the record instruction to the service manager **1204**, the service manager searches for "2" from column **1701** in FIG. **18B** and identifies the line **1709** having the recording identifier "2". Next, assuming that the service manager **1204** passes the channel identifier "2" of the recording data line **1709** to the Tuner **1205c**, the Tuner **1205c** refers to the column **1512** shown in FIG. **16**, and obtains the corresponding tuning information "156 MHz". The Tuner **1205c** passes the tuning information to the QAM demodulation unit **501** via the library **1201b** of the OS **1201**. The QAM demodulation unit **501** demodulates the signal sent from the head end **101** according to the tuning information given to the QAM demodulation unit **501**. The resulting signal is passed by the QAM demodulation unit **501** to the POD **504** when the demodulated channel is a scrambled broadcast, and to the TS decoder when it is not a scrambled program. Next, the service manager **1204** requests the CA **1205b** inside the Java library **1205** to perform descrambling. The CA **1205d** provides the POD **504** with information required for descrambling through the library **1201b** in the OS **1201**. On the basis of such provided information, the POD **504** descrambles the signal provided by the QAM demodulation unit **501**, and passes the resulting signal to the TS decoder **505** and the secondary storage unit **510**. Next, the service manager **1204** requests a REC **1205e** inside the Java library **1205** to record. The REC **1205e** provides a record instruction to the secondary storage unit **510** through the library **1201b** in the OS **1201**. The secondary storage unit stores the data outputted by the POD **504**. Here, the data

stored by the secondary storage unit **510** may also be data outputted by the TS decoder **505**.

Although description is made with the secondary storage unit **510** being exemplified as a storage medium such as a hard disk existing inside a terminal apparatus, it is also possible to have the secondary storage unit **510** existing outside the terminal apparatus **500**, and connected via wiring and the like. Furthermore, the secondary storage unit **510** need not be limited to a hard disk, and may also be an optical disc which can be detached from an optical disc apparatus, as well as media such as a card media.

First, in order to obtain the AIT, the AM **1205b** obtains the PAT and PMT as in the case of the JMF **1205a**, so as to obtain the packet ID of the packet that stores the AIT. Assuming that "2" is the provided channel identifier and that the PAT shown in FIG. **19** and the PMT shown in FIG. **20** are being transmitted, the AM **1205b** obtains the PMT shown in FIG. **20** according to the same procedure followed by the JMF **1205a**. Subsequently, the AM **1205b** extracts, from the PMT, the packet ID of the elementary stream whose stream type is "Data" and which has "AIT" as additional information. As shown in FIG. **20**, the elementary stream in the line **1913** corresponds to such elementary stream, and therefore the AM **1205b** obtains the packet ID "5013" from it.

The AM **1205b** provides the TS decoder **505** with the packet ID of the AIT and the CPU **514** as an output destination through the library **1201b** of the OS **1201**. Then, the TS decoder **505** performs filtering based on such provided packet ID, and passes the resultant to the CPU **514**. Accordingly, the AM **1205b** can collect the packets of AIT. FIG. **21** is a table that schematically shows an example of the collected AIT information. A column **2001** describes identifiers of Java programs. A column **2002** describes control information for controlling the Java programs. The control information includes "autostart", "present", and "kill". "autostart" means that the terminal apparatus **500** automatically executes the program promptly. "present" means that the program is not executed automatically. "kill" means that the program is to be terminated. A column **2003** describes DSMCC identifiers used to extract packet IDs that include Java programs in the DSMCC format. A column **2004** describes program names of the Java programs. Each of columns **2011** and **2012** is a set of information about a Java program. The Java program defined in the column **2011** is a set of an identifier "301", control information "autostart", a DSMCC identifier "1", and a program name "a/TopXlet". The Java program defined in the column **2012** is a set of an identifier "302", control information "present", a DSMCC identifier "1", and a program name "b/GameXlet". Here, these two Java programs have the same DSMCC identifier. This indicates that two Java programs are included in the file system which has been encoded according to the same DSMCC method. Here, only four items of information are specified for the respective Java programs, but more items of information are specified in actuality. Refer to the DVB-MHP specification for detail.

The AM **1205b** finds the "autostart" Java program from the AIT, and extracts the corresponding DSMCC identifier and Java program name. Referring to FIG. **21**, the AM **1205b** extracts the Java program in the line **2011**, and obtains the DSMCC identifier "1" and the Java program name "a/TopXlet".

Next, the AM **1205b** obtains, from the PMT, the packet ID of packets that store Java programs in the DSMCC format, using the DSMCC identifier obtained from the AIT. More specifically, the AM **1205b** obtains, from the PMT, the packet

ID included in the elementary stream whose stream type is "Data" and whose DSMCC identifier in the additional information matches.

Here, assuming that such DSMCC identifier is "1" and the PMT is the one shown in FIG. **20**, the elementary stream in the line **1914** satisfies the above condition. Therefore, the packet ID "5014" is to be extracted.

The AM **1205b** indicates, to the TS decoder **505**, the packet ID of packets in which data is embedded in the DSMCC format as well as the CPU **514** as an output destination through the library **1201b** of the OS **1201**. Here, the packet ID "5014" is provided. Then, the TS decoder **505** performs filtering based on the provided packet ID, and passes the resultant to the CPU **514**. Accordingly, the AM **1205b** can collect the required packets. The AM **1205b** reconstructs the file system from the collected packets according to the DSMCC method, and stores the reconstructed file system into the primary storage unit **511**. The process for extracting data such as the file system from packets in the MPEG-2 transport and storing the extracted data into storage units such as the primary storage unit **511** is hereinafter called download.

FIG. **22** shows an example of the downloaded file system. In the diagram, circles represent directories and squares represent files, where **2101** is a root directory, **2102** is a directory "a", **2103** is a directory "b", **2104** is a file "TopXlet.class", and **2105** is a file "GameXlet.class".

Subsequently, the AM **1205b** passes, to the Java VM **1203**, a Java program to be executed out of the file system downloaded into the primary storage unit **511**. Here, assuming that the Java program name to be executed is "a/TopXlet", a file "a/TopXlet.class", resulting from the appendage of ".class" to the above Java program name, is a file to be executed. "/" is a delimiter between a directory and a file name, and as shown in FIG. **22**, the file **2104** is a Java program to be executed. Next, the AM **1205b** passes the file **2104** to the Java VM **1203**.

The Java VM **1203** executes such received Java program.

Upon the receipt of the identifier of another channel and reproduce instruction, the service manager **1204** terminates the reproduction of the video and audio as well as the execution of the Java program which are being carried out through each library included in the Java library **1205**, through each library included in the same Java library **1205**, and then performs the reproduction of the video and audio as well as the execution of a Java program based on the newly received channel identifier. Furthermore, upon receiving the identifier of another channel and a record instruction, the service manager **1204** does not perform the execution of the Java program. In the case of recording, as the execution of the Java program is not carried out, the amount of use for the CPU **514** and the primary storage unit **511** can be reduced. In addition, the service manager **1204** performs control so that during the recording of a scrambled video, the POD **603** is not ejected even when the POD eject button **1109** is pressed. At this time, before the ejection of the POD **603** is actually executed, a message which indicates that a descrambled video is currently being recorded may also be notified to the user.

The Java library **1205** is a collection of plural Java libraries stored in the ROM **512**. In the present embodiment, the Java library **1205** includes the JMF **1205a**, the AM **1205b**, the Tuner **1205c**, the CA **1205d**, the REC **1205e**, and a POD Lib **1205f**, and so on.

The REC **1205e** has a function for performing recording using the library **1201b**. The REC **1205e** receives, as an input, a record instruction as well as a terminate-recording instruction from the service manager **1204**. In the case where a record instruction is inputted, the REC **1205e** outputs the record instruction to the library **1201b**. In the case where



terminate-recording instruction is inputted, the REC 1205e outputs the terminate-recording instruction to the library 1201b.

Next, the recording automatic-termination function which is an important function of the present embodiment is described.

The service manager 1204 accepts the recording data identifier and the record instruction from the recording unit 1202c, and can store the program in the secondary storage unit 510, through the REC 1205e included in the Java library 1205.

The recording automatic-termination function, which is an important function of the present embodiment, automatically terminates the recording performed by the service manager 1204 in the case where a descrambling-not-possible situation occurs while recording is being executed.

FIG. 23 is a flowchart for the case where a descrambling-not-possible situation occurs during recording.

First, the descrambling judgment unit 515 detects the channel where the descrambling-not-possible situation has occurred (Step 2201). This is performed by detecting, at the terminal apparatus 500-side, the state of attachment/detachment of the POD 504 (for example: by detecting the pressing of an input button for detaching the POD 54; and by carrying out an exchange of signals between the POD 504 and the terminal apparatus 500 at fixed times, where the terminal apparatus detects when the signal from the POD 504 does not come at the fixed time), and by receiving a descrambling-not-possible message from the CPU 706 of the POD 504. Moreover, the POD 504 notifies the descrambling judgment unit 515 that descrambling has become not possible: when a key, per se, cannot be obtained; when an obtained key is different from the required key; when the key is invalid; when in the case where the POD 504 can descramble a plurality of scrambled data, the scrambled data to be recorded cannot be descrambled; and so on.

Next, the descrambling judgment unit 515 passes, to the service manager 1204, the channel identifier for which descrambling has become not possible (Step 2202).

Next, the service manager 1204 searches the management table stored in the secondary storage unit 510, for management information regarding the recording data showing that recording is being executed on the channel indicated by the channel identifier passed on from the descrambling judgment unit 515 and which is in the descrambling-not-possible situation (Step 2203). To be more specific, a search is performed for the line having a channel identifier in column 1702 in FIG. 18B which matches the received channel identifier and at the same time having a value of "1" for the column 1705 which indicates the execution status of recording. Here, assuming that the service manager 1204 receives, from the descrambling judgment unit 515, a message stating the descrambling-not-possible situation for channel identifier "2", line 1709 in the management table shown in FIG. 18B becomes the corresponding recording data.

Next, in the case where the recording data showing that recording is being executed on the channel for which descrambling has become not possible is found (Yes in Step 2204), the service manager 1204 outputs the terminate-recording instruction to the REC 1205e included in the Java library 1205. Upon receiving the inputted terminate-recording instruction, REC 1205e outputs the terminate-recording instruction to the library 1201b to have the recording terminated (Step 2205). In the case where none is found (No in Step 2204), nothing is done. Furthermore, it is possible to judge whether or not to terminate the recording by referring to a setting file which is set in advance by the user.

Next, the service manager 1204 writes into the management table stored in the secondary storage unit 510, the fact that a descrambling-not-possible situation has occurred during recording (Step 2206). To be more specific, the value in column 1707 in the management table shown in FIG. 18B is rewritten from "0" to "1".

Moreover, although in the present embodiment, the EPG 1202, the service manager 1204, and the Java library 1205 are described as software written in the Java language, such programs may be written in languages other than Java, such as C language and native language, and may be installed through hardware.

Moreover, in the present embodiment, in the case where recording data showing that recording is being executed on the channel for which descrambling has become not possible is found, the service manager 1204 terminates the recording, through the REC 1205e. However, it is also possible to notify the EPG 1202 (downloaded application) which issued the record request this time. In this manner, the EPG 1202 is able to know that a problem has occurred on the current recording for the record request it has issued, and processing which is different from that for normal recording data can be carried out on the recording data in which a problem has occurred (for example, performing processes such as: deleting the recording data in which a problem has occurred; notifying the user that a problem has occurred; re-setting the timer for timer-recording when the same program is to be re-aired).

The recording automatic-termination function in the present embodiment has thus been described up to this point. According to this function, it becomes possible to terminate unneeded recording in the case where a descrambling-not-possible situation occurs during recording. Therefore, the strain on the available capacity of the secondary storage unit 510 provided in the terminal apparatus and which records and stores recording data, is eliminated.

## Second Embodiment

In the first embodiment, recording is terminated in the case where a descrambling-not-possible situation occurs during recording. However, when the descrambling-not-possible situation only lasts a short period and scrambling becomes possible again right away, the period in which a program is recorded in the scrambled state is also short. Therefore, there are also cases where continuing the recording of the program is more advantageous for the user.

As such, in the present embodiment, recording is continued even when a descrambling-not-possible situation occurs during recording. However, in the case of writing the program, recorded in the secondary storage unit 510, into a medium inserted in the media writing unit 516, whether or not writing is to be carried out is confirmed with the user.

FIG. 24 is a flowchart for the recording function in the present embodiment, in the case where a descrambling-not-possible situation occurs during the recording of a program.

Step 2301 to step 2304 are the same procedures as step 2201 to step 2204 of the flowchart in FIG. 23.

In the case where recording data showing that recording is being executed on the channel for which descrambling has become not possible is found (Yes in Step 2304), the service manager 1204 writes into the management table stored in the secondary storage unit 510 that a descrambling-not-possible situation has occurred during recording (Step 2305). The process details of step 2305 are the same as in step 2206 in FIG. 23.

As described above, in the present embodiment, the recording into the secondary storage unit **510** is continued even when a descrambling-not-possible situation occurs.

Furthermore, the service manager **1204** instructs the media writing unit **516** to write the program stored in the secondary storage unit **510** into the medium inserted in the media writing unit **516**. At this time, in the case where there is a period in which a descrambling-not-possible situation has occurred during the recording of the recording-subject-program to be written, it is confirmed with the user whether or not the writing is to be carried out. When the user makes an input stating that writing is not to be carried out, the writing is terminated.

FIG. **25** is a flowchart for the writing of a recording-subject-program into a medium.

An EPG **1202** displays a list of programs recorded in the secondary storage unit **510**, on the display **609** through the video output unit **509**. FIG. **26** shows an example of the recording-subject-program list displayed by the EPG. A column **2501** describes the identifier of recording data. A column **2502** describes the name of a recorded program. A column **2503** describes a value which indicates whether or not a descrambling-not-possible situation has occurred during recording. A line **2504** indicates the set of the recording data identifier, the program name, and the value indicating whether or not descrambling became not-possible during recording. By using this display screen, the user can judge whether or not descrambling became not-possible during recording without viewing the details of the recorded program, and the program to be written into the medium can be selected without worry. The EPG receives, through the input unit **513**, the recording data identifier of the program selected by the user, and passes the recording data identifier and a write instruction to the service manager **1204**. The service manager **1204** receives, through the EPG, the identifier of the recording data to be recorded and the write instruction (Step **2401**).

Next, the service manager **1204** verifies whether or not a descrambling-not-possible situation has occurred during the recording of the recording-subject-program to be written (Step **2402**). To be more specific, a line with a matching recording identifier is searched from the management table shown in FIG. **18B**, and the column **1707** value of the found line is verified. When the value is "1", it is judged that a problem has occurred such as when descrambling becomes not possible during recording. It is judged that the problem has not occurred when the value is "0". In the case where the problem has not occurred (No in Step **2403**), a write instruction and the recording data identifier are passed on to the media writing unit **516**, and the media writing unit **516** writes, into the media, the recording-subject-program stored in the secondary storage unit **510** (Step **2408**). In the case where the problem has occurred (Yes in Step **2403**), a message to the user confirming whether or not the writing is to be carried out is outputted to the video output unit **509** (Step **2404**). FIG. **27** shows the display screen of the user confirmation outputted to the audio output unit **509**. A message **2601** is message stating, to the user, that a descrambling-not-possible situation has occurred during the recording of the program to be written into the media. A Yes-button **2602** is a button which is pressed when continuance of the writing is selected by the user, and a No-button **2603** is a button pressed when the user selects not to continue the writing. Next, the service manager **1204** obtains the instruction of the user (Step **2405**), and judges whether or not the user has permitted the writing (Step **2406**). In the case where the user has permitted the writing (Yes in Step **2406**), in other words, when the user has pressed the

Yes-button **2602**, the writing onto the medium is carried out (Step **2408**). On the other hand, in the case where the user does not permit the writing (No in Step **2406**), in other words, when the user has pressed the No-button **2603**, the instruction for the media writing unit **516** is not passed, and nothing is done (Step **2407**). Furthermore, it is also possible to automatically move the process from step **2402** to step **2405** or step **2406** without executing step **2402** and step **2404**.

Moreover, although in the present embodiment, the EPG **1202**, the service manager **1204**, and the Java library **1205** are described as software written in the Java language, such programs may be written in languages other than Java, such as C language and native language, and may be installed through hardware.

According to the aforementioned function, with regard to a program for which a descrambling-not-possible situation has occurred during program recording, the writing of unneeded recording data into a medium is prevented as it is possible to recognize, before writing into the medium, that there is a problem in the recording data due to the occurrence of a descrambling-not-possible situation.

Furthermore, although in the present embodiment, only the occurrence of a problem during recording is notified to the user, the present invention is not limited to this. For example, the time period for which descrambling was not possible can be measured, and in addition to the occurrence of the descrambling-not-possible situation, the time period for which descrambling was not possible may also be notified. In this case, as shown in FIG. **28**, the service manager **1204** writes the measured time period into the management table stored in the secondary storage unit **510**, as a problem period **2701**. Subsequently, when the writing into a medium is requested, a duration **2801** for which descrambling was not possible, as shown in FIG. **29**, is displayed, and the occurrence of a problem during recording is notified to the user. Accordingly, the user is able to know the duration for which the problem has occurred during recording, and can refer to such duration in deciding whether or not to continue with the writing into the medium. In addition, the cause for the occurrence of the problem may also be notified to the user. In this case, the descrambling judgment unit **515** judges whether or not the terminal apparatus **500** physically detects that the POD **504** has been detached, or whether or not the fact that a key required for descrambling can no longer be acquired, is received from the POD **504**. Furthermore, the service manager **1204** writes the result of the judgment by the descrambling judgment unit **515** into the management table as a problem occurrence cause **2702**, as shown in FIG. **28**. When the writing into the medium is requested, the cause **2802** for the descrambling becoming not possible is displayed as shown in FIG. **29**, and the occurrence of the problem during recording is notified to the user. Accordingly, the user is able to know the cause for the occurrence of the problem during recording.

In addition an interface (not shown) can be provided in the display screen in FIG. **29**, for accepting a request to display the recording data for the period before and after the occurrence of the problem. For example, by using the information of the problem period **2701** and displaying the recording data before and after the occurrence of the descrambling-not-possible situation when the input from such interface is received, it is possible to swiftly decide whether or not the recording data during the period for which descrambling was not possible is needed by the user. Therefore, the decision, by the user, as to whether or not to write into a recording medium can be carried out appropriately and swiftly.

Furthermore, when recording is currently being executed for the channel in which descrambling has become not possible, the recording for such channel is terminated in the aforementioned first embodiment, while the recording for such channel is continued in the above-mentioned second embodiment. However, the invention is not limited to such. For example, the duration for which descrambling was not possible can be measured and when descrambling becomes possible again, whether or not to resume the recording may be decided depending on the duration for which descrambling was not possible. In this case, as shown in FIG. 30A, when the duration for which descrambling was not possible (NG) is short and below a predetermined threshold, recording is resumed when descrambling becomes possible again. Furthermore, as shown in FIG. 30B, when the duration for which descrambling was not possible (NG) is long and equals or exceeds the predetermined threshold, recording is not resumed even when descrambling becomes possible again. With this, it is possible to control recording depending on the duration for which descrambling is not possible.

Moreover, in the aforementioned example, the EPG 1202 searches for management information corresponding to the requested recording-subject-program, refers to the recording start time 1703, recording end time 1704, and the problem period 2701 in the found management information, and creates the problem information found in FIG. 26. However, it is also possible that: the EPG 1202 requests the service manager 1204 to search for the management information corresponding to the requested recording-subject-program; the service manager 1204 performs the search according to the received request, using the necessary mathematical functions (or function, as in feature), and returns the search result (the recording start time 1703, recording end time 1704, and the problem period 2701 in the management information) to the EPG 1202; the EPG 1202 creates the problem information using the search result; and the display 609 displays the problem information.

#### Third Embodiment

In the aforementioned second embodiment, when recording data having a problem is written onto the recording medium, problem information is notified to the user. In the present embodiment, when recording data having a problem is reproduced, problem information is notified to the user. In this example, a terminal apparatus (digital broadcast recording apparatus) includes a reproduction unit (not shown in the diagrams) which reproduces a recording-subject-program stored in the secondary storage unit.

FIG. 31 is a diagram showing an example of the problem information which is notified to the user according to the present embodiment.

In FIG. 31, 609 represents the display 609 shown in FIG. 7. A display 1710 describes problem information created based on, for example, the management information corresponding to line 1708 indicated in FIG. 28. Here, description is carried out with "Cinema A" being the recording-subject-program corresponding to line 1708, as an example. Time 2701a indicates the time at which the problem included in the recorded program occurred. Time 2701b indicates the time at which the problem included in the recorded program ended. Segment 2703a indicates the segment throughout which the problem included in the recorded program occurred. Segment 2703b indicates a segment included in the recorded program, which was recorded normally. A display 1711 indicates the percentage occupied by the segment which was recorded normally, within the recording-subject-program. The length of segment

2703a changes depending on the length of time for the problem period 2701 indicated in FIG. 28. The position of segment 2703a changes depending on the start time and end time of the problem period 2701 shown in FIG. 28.

The process for displaying the problem information shown in FIG. 31 is described.

When there is a request, from the user, to reproduce a recording-subject-program, the EPG 1202 searches for management information corresponding to the recording-subject-program that has been requested. Next, the EPG 1202 refers to the recording start time 1703, the recording end time 1704, and the problem period 2701 of the management information obtained from the search, creates the problem information shown in FIG. 31, and shows this on the display 609.

Moreover, in the aforementioned example, the EPG 1202 searches for management information corresponding to the requested recording-subject-program, refers to the recording start time 1703, recording end time 1704 and the problem period 2701 in the found management information, and creates the problem information found in FIG. 31. However, it is also possible that: the EPG 1202 requests the service manager 1204 to search for the management information corresponding to the requested recording-subject-program; the service manager 1204 performs the search according to the received request, using the necessary mathematical functions (or function, as in feature), and returns the search result (the recording start time 1703, recording end time 1704 and the problem period 2701 in the management information) to the EPG 1202; the EPG 1202 creates the problem information using the search result; and the display 609 displays the problem information.

#### Fourth Embodiment

FIG. 32 is a diagram showing an example of a structure diagram of a program stored in the ROM 512 and executed by the CPU 514, in the present embodiment.

Note that units in FIG. 32 having reference numbers that are the same as those in FIG. 13 are the same as, or correspond to, such units in FIG. 13.

Furthermore, as the hardware structure in the present embodiment is approximately the same as that shown in FIG. 6, detailed description is omitted.

In the case where recording is currently being executed for the channel in which descrambling becomes not possible, the recording for such channel is terminated in the aforementioned first embodiment, and the recording for such channel is continued in the aforementioned second embodiment. The present embodiment is characterized by the provision of a recording resumption judgment unit 1205g which terminates the recording when the channel falls into a descrambling-not-possible situation, and then measures the duration for which descrambling was not possible when descrambling becomes possible again, and decides whether or not to resume the recording depending on the measured duration.

To be more specific, description is made for the example where the Java library 1205 includes the recording resumption judgment unit 1205g as a component element. Furthermore, as an additional function is given to the service manager 1204 shown in FIG. 13, the reference number 1204a is assumed here for the service manager 1204.

In addition, it is assumed that aside from having its aforementioned function, the descrambling judgment unit 515 has a function for outputting, to the service manager 1204a, the identifier of the channel for which descrambling has become possible again, in the case where the descrambling becomes possible again after a descrambling-not-possible situation.

As the other areas are the same as in the second embodiment, description in the present embodiment shall be limited to the process of recording resumption.

Here, description is made regarding the operation, for a recording number "1", in which a descrambling-not-possible situation occurs from 10:40, and recording is resumed at 10:45.

First, as previously described, the descrambling judgment unit 515 outputs, to the service manager 1204, the identifier of the channel which is in the descrambling-not-possible situation.

Upon receiving, from the descrambling judgment unit 515, the identifier of the channel for which descrambling has become not possible, the service manager 1204a searches the management table for the recording number being recorded with the inputted channel identifier. Next, the execution status 1705 of the found recording number is rewritten with "3" indicating a status of recording terminated due to a problem. Next, the present time is written as the start time of the problem period for the found recording number. To be more specific, after obtaining 10:40 which is the present time information using, for example, the time obtainment function of the library 1201b within the OS 1201, the service manager 1204a rewrites 10:40 as the start time of the problem period in the management table (see FIG. 33).

The service manager 1204a outputs a terminate-recording instruction to the REC 1205e. Upon receiving the terminate-recording instruction, the REC 1205e terminates the program recording according to the details of the instruction. At this time, the REC 1205e carries out the termination of the recording using a function of the library 1201b within the OS 1201, necessary for recording termination.

Next, in the case where it is judged that descrambling is possible again after it was judged that descrambling was not possible, the descrambling judgment unit 515 outputs, to the service manager 1204a, the identifier of the channel for which descrambling has become possible again.

Upon receiving, from the descrambling judgment unit 515, the identifier of the channel for which descrambling has become possible again, the service manager 1204a searches the management table for the recording number corresponding to the inputted channel identifier. Next, the present time is written as the end time of the problem period for the found recording number. To be more specific, after obtaining 10:45 which is the present time information using, for example, the time obtainment function of the library 1201b within the OS 1201, the service manager 1204a rewrites 10:45 as the end time of the problem period 2701 in the management table (see FIG. 34). Then, the service manager 1204a outputs, to the recording resumption judgment unit 1205g, a judge-resumption instruction and the found recording number.

Next, the recording resumption judgment unit 1205g judges whether or not recording can be resumed for the recording-subject-program corresponding to the received recording number, and outputs the judgment result to the service manager 1204a. The specific operation of the recording resumption judgment unit 1205g will be described later.

Next, the service manager 1204a receives, from the recording resumption judgment unit 1205g, the judgment result for the resumption of recording, and operates according to the judgment result. For example, when the judgment result indicates the resumption of recording, service manager 1204a outputs a record instruction to the REC 1205e, and rewrites the value of the column 1705 corresponding to the recording number to "4" which indicates the resumption of recording from the status of recording terminated due to a problem (see FIG. 35). Upon receiving the record instruction, the REC

1205e carries out the recording using a function of the library 1201b within the OS 1201, necessary for recording.

Furthermore, when the judgment result indicates the non-resumption of recording, the service manager 1204a does not output the record instruction to the REC 1205e. Here, the management table is left as it is in FIG. 34.

Next, the specific operation of the recording resumption judgment unit 1205g is described.

The recording resumption judgment unit 1205g has a function for comparing the problem period during the recording of the program and a predetermined period, and deciding whether or not to resume recording.

Upon receiving the judge-recording resumption instruction and the program number from the service manager 1204a, the recording resumption judgment unit 1205g obtains the problem period for the received recording number by referring to the management table. In the case where a plurality of problem periods exists in the management table for the received recording number, the most recent problem period is referred to and retrieved. For example, assuming the management table is that in FIG. 34, in the case where the recording number "1" is received, the recording resumption judgment unit 1205g refers to the management table and obtains "10:40 to 10:45" which is the most recent problem period among the plurality of problem periods. The recording resumption judgment unit 1205g calculates the predetermined period to be compared to the acquired problem period. For example, referring to the management table, the recording resumption judgment unit 1205g assumes, as the predetermined number, a value (in other words, a time interval) resulting from the subtraction, from the timer-recording end time indicated in column 1704 of the inputted recording number, of the problem start time, indicated in column 2701, at which the descrambling-not-possible situation occurred. The recording resumption judgment unit 1205g compares the acquired problem period (in this example, 5 minutes) and the calculated predetermined number (in this example, 20 minutes), and judges not to resume recording when the problem period is longer. When the problem period is shorter than the predetermined period, recording resumption judgment unit 1205g judges that recording is to be resumed. The recording resumption judgment unit 1205g outputs, to the service manager 1204a, the judgment result of whether or not to resume recording. In this manner, the resumption of recording beyond the recording end time is eliminated.

Next, the recording resumption in the present embodiment is described using flowcharts.

FIG. 36 is a flowchart showing an example of the recording resumption in the present embodiment. First, the descrambling judgment unit 515 detects the descrambling-not-possible situation, and outputs, to the service manager 1204a, the identifier of the channel for which descrambling has become not possible (Step 3601).

Next, upon receiving the identifier of the channel for which descrambling has become not possible from the descrambling judgment unit 515, the service manager 1204a causes the recording to be terminated by writing the problem start time for the problem period 2701 of the corresponding recording number in the management table, and outputting a terminate-recording instruction to the REC 1205e (Step 3602).

Next, the descrambling judgment unit 515 detects a descrambling-possible situation, and outputs, to the service manager 1204a, the identifier of the channel for which descrambling has become possible (Step 3603).

Next, upon receiving the identifier of the channel for which descrambling has become possible from the descrambling judgment unit 515, the service manager 1204a writes the

problem end time for the problem period **2701** of the corresponding recording number in the management table (Step **3604**).

Next, the recording resumption judgment unit **1205g** refers to the problem period corresponding to the recording number of the corresponding channel identifier in the management table, then calculates the predetermined period (Step **3605**), and compares the problem period and the predetermined period (Step **3606**). In the case where, as a result of the comparison, the problem period is shorter (Yes in Step **3606**), the recording resumption judgment unit **1205g** judges that the recording is to be resumed, and outputs the judgment result to the service manager **1204a**. The service manager **1204a** causes the resumption of the terminated recording by outputting a record instruction to the REC **1205e** (Step **3607**).

Furthermore, in the case where, according to the comparison, it is judged that recording is not to be resumed (No in Step **3606**), the service manager **1204a** does not output the record instruction to the REC **1205e**. In this case, the management table is left as it is in FIG. **34**.

The flowchart for the recording resumption in the present embodiment is thus described above.

Moreover, instead of calculating the predetermined period, the recording resumption judgment unit **1205g** may previously store a predetermined period in the secondary storage unit **510**, then compare the stored predetermined period and the problem period **2701**, and judge the resumption of recording based on the comparison result.

In this case, when the duration for which descrambling was not possible (NG) is short and below a predetermined threshold T, as in FIG. **30A**, recording is resumed at the point where descrambling becomes possible again. Furthermore, when the duration for which descrambling was not possible (NG) is long and equals or exceeds the predetermined threshold T as in FIG. **30B**, recording is not resumed even when descrambling becomes possible again. With this, it is possible to control the recording depending on the duration for which descrambling is not possible.

Furthermore, the problem period obtained by the recording resumption judgment unit **1205g** by referring to the management table may be the total of the problem periods for an inputted recording number. For example, in the case where the recording number "1" is inputted, the total of the problem periods is, with reference to FIG. **35**, the total period indicated by the 5 minutes for the problem period "9:35 to 9:40", the 20 minutes for the problem period "10:10 to 10:30", . . . , and the 5 minutes for the problem period "10:40 to 10:45".

#### Fifth Embodiment

In the present embodiment, when recording is currently being executed for the channel for which descrambling has become not possible, the recording for that channel is terminated, and when descrambling becomes possible again, the time at which descrambling became possible and the timer-recording schedule are compared and the resumption of the recording is decided depending on the comparison result.

In the present embodiment, the judgment function of the recording resumption judgment unit **1205g** has a different function to that in the fourth embodiment. As the other areas are the same as in the fourth embodiment, description is omitted here.

The specific operation of the recording resumption judgment unit **1205g** in the present embodiment is described.

The recording resumption judgment unit **1205g** compares the end time of the problem period during program recording

and the end time of the timer-recording, and decides whether or not to resume the recording.

Upon receiving the judge-recording resumption instruction and the program number from the service manager **1204a**, the recording resumption judgment unit **1205g** obtains the problem end time of problem period for the received recording number by referring to the management table. In the case where a plurality of problem periods exists in the management table for the received recording number, the end time of the most recent problem period is referred to. For example, assuming that the management table is that in FIG. **34**, in the case where the recording number "1" is received, the recording resumption judgment unit **1205g** refers to the management table and refers to "10:40 to 10:45" which is the most recent problem period among the plurality of problem periods, and obtains the problem end time of 10:45.

Next, the recording resumption judgment unit **1205g** compares the obtained problem end time and the timer-recording end time. For example, recording resumption judgment unit **1205g** refers to the management table and compares the timer-recording end time **1704** for the received recording number and the problem end time indicated by the problem period **2701**.

The recording resumption judgment unit **1205g** compares the referred problem end time (in this example, 10:45) and the timer-recording end time (in this example, 11:00), and judges not to resume recording in the case where the problem end time comes after the timer-recording end time. When the problem end time comes before the timer-recording end time, it is judged that recording is to be resumed. The recording resumption judgment unit **1205g** outputs the judgment result for whether or not recording is to be resumed. In this manner, the resumption of recording beyond the recording end time is eliminated.

Next, the recording resumption in the present embodiment is described using flowcharts.

FIG. **37** is a flowchart showing an example of the recording resumption in the present embodiment. First, the descrambling judgment unit **515** detects the descrambling-not-possible situation, and outputs, to the service manager **1204a**, the identifier of the channel for which descrambling has become not possible (Step **3701**).

Next, upon receiving the identifier of the channel for which descrambling has become not possible from the descrambling judgment unit **515**, the service manager **1204a** causes the recording to be terminated by writing the problem start time for the problem period **2701** of the corresponding recording number in the management table, and outputting a terminate-recording instruction to the REC **1205e** (Step **3702**).

Next, the descrambling judgment unit **515** detects a descrambling-possible situation, and outputs, to the service manager **1204a**, the identifier of the channel for which descrambling has become possible (Step **3703**).

Next, upon receiving the identifier of the channel for which descrambling has become possible from the descrambling judgment unit **515**, the service manager **1204a** writes the problem end time for the problem period **2701** of the corresponding recording number in the management table (Step **3704**).

Next, the recording resumption judgment unit **1205g** refers to and obtains the problem end time of the problem period for the received recording number, and the timer-recording end time of the recording number (Step **3705**).

Next, recording resumption judgment unit **1205g** compares the problem end time of the problem period for the

received recording number, and the recording end time of the timer-recording of the recording number (Step 3706).

In the case where, as a result of the comparison, the problem end time comes before the timer-recording end time (Yes in Step 3706), the recording resumption judgment unit 1205g judges that the recording is to be resumed, and outputs the judgment result to the service manager 1204a. The service manager 1204a causes the resumption of the terminated recording by outputting a record instruction to the REC 1205e (Step 3707).

Furthermore, in the case where, according to the comparison, it is judged that recording is not to be resumed (No in Step 3706), the service manager 1204a does not output the record instruction to the REC 1205e. In this case, the management table is left as it is in FIG. 34.

The flowchart for the recording resumption in the present embodiment is thus described above.

According to the present embodiment, it is possible to control the recording depending on the time at which descrambling becomes possible after the occurrence of the problem. In this case, as shown in FIG. 38, when the time at which recovery is made, from the descrambling-not-possible situation to a descrambling-possible (OK) again, is within the span of the timer-recording schedule, recording is resumed at the point where descrambling becomes possible again. Furthermore, as shown in FIG. 39, when the time at which descrambling becomes possible again is outside the span of the timer-recording schedule, recording is not resumed even when descrambling becomes possible again.

#### Sixth Embodiment

In the aforementioned first to fifth embodiments, the descrambling-not-possible and descrambling-possible situations are assumed as the condition for recording termination and recording resumption. In the present embodiment, problem situations originating from hardware such as an IO bandwidth deficiency (performance concerning the amount of data transferred between hardware), and the condition of tuning influenced by noise, are also assumed as conditions for recording termination and recording resumption. The IO bandwidth deficiency described here indicates the insufficiency of the bandwidth between the TS decoder 505 and the secondary storage unit 510 in comparison to the amount of data transferred from the TS decoder 505 and the secondary storage unit 510. Furthermore, in the present embodiment, the re-activation of the service manager 1204, the EPG 1202, and the Java VM 1203, caused by a fatal error brought about by a program operating on the OS 1201, is also assumed as a condition for recording resumption.

In the present embodiment, in order to execute the recording termination and recording resumption due to hardware-caused problem situations, the functions of the REC 1205e and the Tuner 1205c of the Java library 1205, and the functions of the service manager 1204a are different from those in the first to fifth embodiments. As the other areas are the same as in the first to fifth embodiments, description in the present embodiment shall be limited to recording termination and recording resumption due to hardware problems.

Furthermore, as the hardware structure in the present embodiment is approximately the same as that shown in FIG. 6, detailed description shall be omitted here.

In addition to the functions of the CPU 514 described in the aforementioned embodiments, the CPU 514 detects data input/output-related errors, and notifies the error occurrence to the REC 1205e through the library 1201b. In addition, the CPU 514 outputs, to the secondary storage unit 510, a store

instruction and input destination of data to be stored. The CPU 514 detects a data input/output-related error occurring during the outputting, to the secondary storage unit 510, of the store instruction and input destination of the data to be stored.

The data input/output-related error may be, for example, an error caused by an IO bandwidth deficiency occurring in the case where the bandwidth between the TS decoder 505 and the secondary storage unit 510 is insufficient in comparison to the amount of data transferred from the TS decoder 505 and the secondary storage unit 510. Furthermore, it may also be a storage capacity deficiency error occurring in the case of attempting to store data which exceeds the storage capacity of the secondary storage unit 510. In addition, the CPU 514 detects the recovery from the aforementioned IO bandwidth deficiency-caused error and storage capacity deficiency error.

The QAM demodulation unit 501 detects a tuning-related error and outputs the detection result to the Tuner 1205c through the library 1201b. The tuning-related error may be, for example, a tuning-failure error occurring when noise intrudes into data sent from the head end 101 and correct data is not inputted to the QAM demodulation unit 501, and when demodulation cannot be carried out due to cable disconnection. Furthermore, after the occurrence of a tuning-related error, the QAM demodulation unit 501 notifies the tuner 1205c, through the library 1201b, of the recovery from the error and that normal processing can be carried out.

The description of the terminal apparatus 500 in the present embodiment is made up to this point.

Next, the program stored in the ROM 512 and executed by the CPU 514, in the present embodiment, is described using FIG. 40. As new functions are added, in the present embodiment, to the Tuner 1205c, the REC 1205e, and the service manager 1204 in the first to fifth embodiments, they are made to assume reference numbers as Tuner 12051c, REC 12051e, and service manager 1204b. Aside from these, everything else is the same as in the first to fifth embodiments.

The Tuner 12051c receives the tuning error occurring in the QAM demodulation unit 501, through the library 1201b. After receiving the error, the Tuner 12051c outputs, to the service manager 1204b, the identifier of the channel in which the tuning error occurred. Furthermore, in the case where the Tuner 12051c receives, from the QAM demodulation unit 501, notification of the recovery from the tuning-related error, the Tuner 12051c outputs, to the service manager 1204b, the identifier of the channel which has recovered from the error.

The REC 12051e receives, through the library 1201b, notification of an IO bandwidth deficiency-cause error, a storage capacity deficiency error, and the like, detected by the CPU 514 during recording. After receiving notification of the error, the REC 12051e notifies the service manager 1204b of the occurrence of the IO bandwidth deficiency-caused error, the storage capacity deficiency error, and the like. Furthermore, when the CPU 514 detects the recovery from the IO bandwidth deficiency-caused error and the storage capacity deficiency error, the REC 12051e receives, through the library 1201b, notification of the recovery from the error. After receiving notification of the recovery from the error, the REC 12051e notifies the service manager 1204b of the recovery from the error.

Upon receiving, from the Tuner 12051c, the identifier of the channel in which a tuning error occurred, the service manager 1204b searches the management table for the recording number being recorded for the inputted channel identifier. Next, the execution status 1705 of the found recording number is rewritten with "3" indicating a status of recording terminated due to a problem. Next, the present time is written as the start time of the problem period for the found

recording number. To be more specific, after obtaining 10:40 which is the present time information using, for example, the time obtainment function of the library 1201b within the OS 1201, the service manager 1204b rewrites 10:40 as the start time of the problem period 2701 in the management table (see FIG. 33).

The service manager 1204b outputs a terminate-recording instruction to the REC 12051e. Upon receiving the terminate-recording instruction, the REC 12051e terminates the program recording according to the details of the instruction. At this time, the REC 12051e carries out the termination of the recording using a function of the library 1201b within the OS 1201, necessary for recording termination.

Next, in the case where the Tuner 12051c receives, from the QAM demodulation unit 501, notification of the recovery from the tuning-related error, the Tuner 12051c outputs, to the service manager 1204b, the identifier of the channel that has recovered from the error.

Upon receiving, from the Tuner 12051c, the identifier of the channel which has recovered from the error, the service manager 1204b searches the management table for the recording number corresponding to the inputted channel identifier. Next, the present time is written as the end time of the problem period for the found recording number. To be more specific, after obtaining 10:45 which is the present time information using, for example, the time obtainment function of the library 1201b within the OS 1201, the service manager 1204a rewrites 10:45 as the end time of the problem period in the management table (see FIG. 34). Then, the service manager 1204a outputs, to the recording resumption judgment unit 1205g, a judge-resumption instruction and the found recording number.

Next, the recording resumption judgment unit 1205g judges whether or not recording can be resumed for the recording-subject-program corresponding to the received recording number, and outputs the judgment result to the service manager 1204b. As the specific operation of the recording resumption judgment unit 1205g is already described in the fourth and fifth embodiments, description shall be omitted here (this example exemplifies that in the fifth embodiment).

Next, the service manager 1204b receives, from the recording resumption judgment unit 1205g, the judgment result for the resumption of recording, and operates according to the judgment result. For example, when the judgment result indicates the resumption of recording, service manager 1204b outputs a record instruction to the REC 12051e, and rewrites the value of the column 1705 corresponding to the recording number to "4" which indicates the resumption of recording from the status of recording terminated due to a problem (see FIG. 35). Upon receiving the record instruction, the REC 12051e carries out the recording using a function of the library 1201b within the OS 1201, necessary for recording.

On the other hand, when the judgment result indicates the non-resumption of recording, the service manager 1204b does not output the record instruction to the REC 12051e. Here, the management table is left as it is in FIG. 34.

Furthermore, upon receiving, from the REC 12051e, notification of the IO bandwidth deficiency-caused error and the storage capacity deficiency error, the service manager 1204b searches the management table for the recording number that is being recorded by the REC 12051e. Next, the execution status 1705 of the found recording number is rewritten with "3" indicating a status of recording terminated due to a problem. Next, the present time is written as the start time of the problem period for the found recording number. To be more specific, after obtaining 10:40 which is the present time infor-

mation using, for example, the time obtainment function of the library 1201b within the OS 1201, the service manager 1204b rewrites 10:40 as the start time of the problem period 2701 in the management table (see FIG. 33).

The service manager 1204b outputs a terminate-recording instruction to the REC 12051e. Upon receiving the terminate-recording instruction, the REC 12051e terminates the program recording according to the details of the instruction. At this time, the REC 12051e carries out the termination of the recording using a function of the library 1201b within the OS 1201, necessary for recording termination.

Next, in the case where the REC 12051e receives, from the CPU 514, notification of the recovery from the IO bandwidth deficiency-caused error and the storage capacity deficiency error, the REC 12051e notifies the service manager 1204b of the recovery from the error.

Upon receiving, from the REC 12051e, notification of the recovery from the IO bandwidth deficiency-caused error and the storage capacity deficiency error, the service manager 1204b searches the management table for the recording number corresponding to the terminated recording. Next, the present time is written as the end time of the problem period for the found recording number. To be more specific, after obtaining 10:45 which is the present time information using, for example, the time obtainment function of the library 1201b within the OS 1201, the service manager 1204a rewrites 10:45 as the end time of the problem period in the management table (see FIG. 34). Then, the service manager 1204a outputs, to the recording resumption judgment unit 1205g, a judge-resumption instruction and the found recording number.

Next, the recording resumption judgment unit 1205g judges whether or not recording can be resumed for the recording-subject-program corresponding to the received recording number, and outputs the judgment result to the service manager 1204b. As the specific operation of the recording resumption judgment unit 1205g is already described in the fourth and fifth embodiments, description shall be omitted here (this example exemplifies that in the fifth embodiment).

Next, the service manager 1204b receives, from the recording resumption judgment unit 1205g, the judgment result for the resumption of recording, and operates according to the judgment result. For example, when the judgment result indicates the resumption of recording, service manager 1204a outputs a record instruction to the REC 12051e, and rewrites the value of the column 1705 corresponding to the recording number to "4" which indicates the resumption of recording from the status of recording terminated due to a problem (see FIG. 35). Upon receiving the record instruction, the REC 12051e carries out the recording using a function of the library 1201b within the OS 1201, necessary for recording.

Furthermore, when the judgment result indicates the non-resumption of recording, the service manager 1204b does not output the record instruction to the REC 12051e. Here, the management table is left as it is in FIG. 34.

Furthermore, after the re-activation of the service manager 1204b, the EPG 1202, and the Java VM 1203, caused by a fatal error brought about by a program operating on the OS 1201, the service manager 1204b in the present embodiment searches the management table for the recording number with an execution status 1705 bearing a value other than "2" which indicates recording ended. In other words, it searches for a timer-recording process in which the timer-recording is not yet completed until the end. Next the service manager 1204b

outputs, to the recording resumption judgment unit **1205g**, the found recording number and a judge-recording resumption instruction.

Upon receiving the found recording number and a judge-recording resumption instruction from service manager **1204b**, the recording resumption judgment unit **1205g** refers to the recording start time and recording end time for the received recording number, in the management table, and judges that the recording is to be resumed when the present time is within such span. When the present time is not within such span, it is judged that recording is not to be resumed. The recording resumption judgment unit **1205g** outputs the judgment result to the service manager **1204b**.

Next, the service manager **1204b** receives, from the recording resumption judgment unit **1205g**, the judgment result for the resumption of recording, and operates according to the judgment result. For example, when the judgment result indicates the resumption of recording, service manager **1204a** outputs a record instruction to the REC **12051e**, and rewrites the value of the column **1705** corresponding to the recording number to "4" which indicates the resumption of recording from the status of recording terminated due to a problem (see FIG. **35**). Upon receiving the record instruction, the REC **12051e** carries out the recording using a function of the library **1201b** within the OS **1201**, necessary for recording.

Furthermore, when the judgment result indicates the non-resumption of recording, the service manager **1204b** does not output the record instruction to the REC **12051e**. Here, the management table is left as it is in FIG. **34**.

Next, the recording resumption in the present embodiment is described using flowcharts.

FIG. **41** is a flowchart showing an example of the recording resumption in the present embodiment. First, in the case where an IO bandwidth deficiency-caused error and a storage capacity deficiency error occur, the REC **12051e** receives, from the CPU **514**, notification of the IO bandwidth deficiency-caused error and the storage capacity deficiency error, and notifies the service manager **1204b** of the error occurrence. Furthermore, in the case where the QAM demodulation unit **501** detects a tuning error, the Tuner **12051c** receives notification of the tuning error from the QAM demodulation unit **501**, and then outputs, to the service manager **1204b**, the identifier of the channel in which the tuning error occurred (Step **4101**).

Next, upon receiving the error notification from the REC **12051e**, or receiving, from the Tuner **12051c**, the identifier of the channel in which the tuning error occurred, the service manager **1204b** causes the recording to be terminated by writing the problem start time for the problem period **2701** of the corresponding recording number in the management table, and outputting a terminate-recording instruction to the REC **12051e** (Step **4102**).

Next, in the case where the CPU **514** detects a recovery from the IO bandwidth deficiency-caused error and the storage capacity deficiency error, the REC **12051e** receives, from the CPU **514**, notification of the recovery from the error, and then notifies the service manager **1204b** of the recovery from the error. Furthermore, in the case where the QAM demodulation unit **501** detects, after the occurrence of the tuning-related error, a recovery from the error and that normal processing can be carried out, the Tuner **12051c** receives, from the QAM demodulation unit **501**, notification of the recovery from the error, and outputs, to the service manager **1204b**, the identifier of the channel which has recovered from the error (Step **4103**).

Next, the service manager **1204b** writes the problem end time for the problem period **2701** of the corresponding

recording number in the management table, based on the information received in Step **4103** (Step **4104**).

Next, the recording resumption judgment unit **1205g** refers to and obtains the problem end time of the problem period for the received recording number, and the timer-recording end time for the recording number (Step **4105**).

Next, recording resumption judgment unit **1205g** compares the problem end time of the problem period for the received recording number, and the timer-recording end time for the recording number (Step **4106**).

In the case where, as a result of the comparison, the problem end time comes before the timer-recording end time (Yes in Step **4106**), the recording resumption judgment unit **1205g** judges that the recording is to be resumed, and outputs the judgment result to the service manager **1204b**. The service manager **1204b** causes the resumption of the terminated recording by outputting a record instruction to the REC **12051e** (Step **4107**).

Furthermore, in the case where, according to the comparison, it is judged that recording is not to be resumed (No in Step **4106**), the service manager **1204b** does not output the record instruction to the REC **12051e**. In this case, the management table is left as it is in FIG. **34**.

The flowchart for the recording resumption in the present embodiment is thus described above.

Next, description is made regarding the flow of the automatic recording re-starting upon re-activation of the service manager **1204b**, the EPG **1202**, and the Java VM **1203**. FIG. **42** is a flowchart showing an example of the starting of recording upon re-activation, in the sixth embodiment.

First, the service manager **1204**, the EPG **1202**, and the Java VM **1203** are re-activated due to a fatal error brought about by a program operating on the OS **1201** (Step **4201**).

Next the service manager **1204b** searches the management table for the recording number with an execution status **1705** bearing a value other than "2" which indicates recording ended, and outputs, to the recording resumption judgment unit **1205g**, the found recording number and a judge-recording resumption instruction (Step **4202**).

Next, the recording resumption judgment unit **1205g** judges whether or not the present time is in between the recording start time and the recording end time (Step **4203**).

When the present time is in between the recording start time and the recording end time (Yes in Step **4203**), the recording resumption judgment unit **1205g** judges that the recording is to be started, and outputs the judgment result for starting recording to the service manager **1204b**. Upon being inputted with the judgment result for starting recording, the service manager **1204b** outputs a record instruction to the REC **12051e** (Step **4204**). When the present time is not in between the recording start time and the recording end time (No in Step **4203**), the service manager **1204b** concludes the process without outputting the record instruction to the REC **12051e**.

Accordingly, even in the case where the re-activation of the service manager **1204b**, the EPG **1202**, and the Java VM **1203** occurs during the recording of a program, as long as the time after the re-activation is within the timer-recording schedule, recording is automatically resumed. Accordingly, there is an effect that it becomes unnecessary for the EPG **1202**, which is a downloaded Java application, to verify timer-recordings that need to be started, after the re-activation of the service manager **1204b**, the EPG **1202**, and the Java VM **1203**.

The digital broadcast recording apparatus according to the present invention is useful as it can reduce the waste of storage capacity by preventing the unintended recording of defective program video onto a recording medium such as a CD-R



and a DVD-R and, in the case of unintended recording of defective program video, allows the user to know about the recorded defective video before it is reproduced, thereby eliminating any annoyance that the user may feel in finding out about the recorded defective program video while it is already being reproduced. The digital broadcast recording apparatus according to the present invention is useful in an apparatus which stores scrambled data such as a DVD recorder, a digital television, a personal computer, and a mobile phone.

Although only some exemplary embodiments of this invention have been described in detail above, those skilled in the art will readily appreciate that many modifications are possible in the exemplary embodiments without materially departing from the novel teachings and advantages of this invention. Accordingly, all such modifications are intended to be included within the scope of this invention.

What is claimed is:

- [1.** A digital broadcast recording apparatus, comprising:  
 a first demodulator operable to demodulate received scrambled data using information including a designated frequency, and to output the demodulated scrambled data;  
 a descrambler operable to descramble the scrambled data demodulated by said first demodulator, and to output an MPEG-2 transport stream;  
 a retriever operable to retrieve, from the MPEG-2 transport stream outputted by said descrambler, AV data and a file system which makes up an application;  
 an executioner operable to execute the application made up by the file system;  
 a recording controller operable to receive a record request from the executed application, and to control recording according to the received record request;  
 a recorder operable to record the retrieved AV data according to an instruction from said recording controller;  
 a holder operable to hold management information for managing the recorded data; and  
 a detector operable to detect a problem which occurs in processing performed from after the demodulating of the scrambled data by said first demodulator until the retrieving of the AV data,  
 wherein, in the case where said detector detects the problem during recording of data by said recorder, said recording controller is operable to write, into the management information, the detected problem and a time at which the problem occurred.]
- [2.** The digital broadcast recording apparatus of claim 1, wherein, in the case where said detector detects the problem, said recording controller is operable to notify the detection of the problem to the application issuing the record request.]
- [3.** The digital broadcast recording apparatus of claim 1, wherein said detection is operable to judge whether or not descrambling by said descrambler is possible, and to detect the problem in the case where descrambling is not possible.]
- [4.** The digital broadcast recording apparatus of claim 3, wherein said detector is operable to detect the problem in the case where key information becomes invalid, the key information corresponding to a time limit for using said descrambler.]
- [5.** The digital broadcast recording apparatus of claim 3, further comprising:  
 a second demodulator operable to demodulate key information used in descrambling, the key information being

included in a frequency band that is different from a frequency band of the scrambled data,  
 wherein said descrambler stores, inside said descrambler, the key information used in descrambling, which is demodulated by said second demodulator, and  
 said detector is operable to detect the problem in one of the cases where: the key information used in descrambling stored within said descrambler is invalid; and the key information used in descrambling cannot be demodulated by said demodulator.]

**[6.** The digital broadcast recording apparatus of claim 3, wherein said descrambler is detachable from said digital broadcast recording apparatus, and  
 said detector is operable to detect the problem in the case where said descrambler is detached from said digital broadcast recording apparatus.]

**[7.** The digital broadcast recording apparatus of claim 1, where said descrambler is detachable from said digital broadcast recording apparatus, and  
 said digital broadcast recording apparatus further comprises a detachment controller operable to prohibit detachment of said descrambler from said digital broadcast recording apparatus while data is being stored.]

**[8.** The digital broadcast recording apparatus of claim 1, wherein said recording controller is operable to control said recording unit to terminate the recording, after said detector detects the problem.]

**[9.** The digital broadcast recording apparatus of claim 1, wherein said recording controller is operable to control said recorder to continue the recording in the case where said detector detects the problem.]

**[10.** The digital broadcast recording apparatus of claim 1, wherein, in the case where, after the recording by said recorder is terminated when said detector detects the problem, said detector can no longer detect the problem, said recording controller is operable to control resumption of the recording by said recorder, according to a predetermined condition.]

**[11.** The digital broadcast recording apparatus of claim 10, further comprising:

a measurer operable to measure, in the case where said detector detects the problem during the recording of the AV data, a time period from the detection of the problem to recovery from the problem,  
 wherein said recording controller is operable to write the measure time period into the management information.]

**[12.** The digital broadcast recording apparatus of claim 11, wherein the predetermined condition is that when the time period measured by said measurer is equal to or shorter than a predetermined time period, the recording by said recorder is to be resumed.]

**[13.** The digital broadcast recording apparatus of claim 1, wherein, in the case where said detector detects the problem, said recording controller is operable to identify a cause of the problem, and to write the identified cause into the management information.]

**[14.** The digital broadcast recording apparatus of claim 3, where said descrambler is operable to simultaneously descramble a plurality of scrambled data, and  
 said detector is operable to judge whether or not descrambling for each of the plurality of scrambled data is possible, and to detect the problem in the case where descrambling is not possible for scrambled data, among the plurality of scrambled data, corresponding to the AV data being recorded by said recorder.]

39

**[15.** The digital broadcast recording apparatus of claim 1, further comprising:

a media writer operable to store, onto a writable medium, the AV data recorded by said recorder.]

**[16.** The digital broadcast recording apparatus of claim 15, wherein said media writer is operable to refer to the management information when the recorded AV data is to be stored onto the medium, and to not store the AV data onto the medium in the case where the problem occurred during the recording of the AV data to be stored.]

**[17.** The digital broadcast recording apparatus of claim 15, further comprising:

a notifier operable to refer to the management information when the recorded AV data is to be stored onto the medium, and, in the case where the problem occurred during the recording of the AV data to be stored, to notify a user of the occurrence of the problem during the recording.]

**[18.** The digital broadcast recording apparatus of claim 17, further comprising:

an instruction obtainer operable to obtain, from the user, an instruction which is based on the notification by said notifier,

wherein said media writer is operable to store the data onto the medium in the case where the instruction obtained by said instruction obtainer is a write instruction.]

**[19.** The digital broadcast recording apparatus of claim 1, further comprising:

a reproducer operable to reproduce the recorded AV data; and

a notifier operable to refer to the management information when the recorded AV data is to be reproduced by said reproducer, and, in the case where the problem occurred during the recording of the AV data to be reproduced, to notify a user of the occurrence of the problem during the recording.]

**[20.** A digital broadcast recording method, comprising: demodulating received scrambled data using information including a designated frequency, and outputting the demodulated scrambled data;

descrambling the scrambled data demodulated in said demodulating, and outputting an MPEG-2 transport stream;

retrieving, from the MPEG-2 transport stream outputted in said descrambling, AV data and a file system which make up an application;

executing the application made up by the file system;

controlling recording according to a record request received from the executed application;

recording the retrieved AV data according to an instruction given in said controlling; and

detecting a problem which occurs in processing performed from after the demodulation of the scrambled data in said demodulating until said retrieving of the AV data,

wherein, in said controlling, the detected problem and a time at which the problem occurred are written into management information for managing the recorded data, in the case where, in said detecting, the problem is detected during the recording of data in said recording.]

40

21. A digital broadcast recording apparatus comprising: a first demodulator operable to demodulate received scrambled data using information including a designated frequency, and to output the demodulated scrambled data;

a descrambler operable to descramble the scrambled data demodulated by said first demodulator, and to output an MPEG-2 transport stream;

a retriever operable to retrieve, from the MPEG-2 transport stream outputted by said descrambler, AV data and a file system which makes up an application;

an executioner operable to execute the application made up by the file system;

a recording controller operable to receive a record request from the executed application, and to control recording according to the received record request;

a recorder operable to record the retrieved AV data according to an instruction from said recording controller;

a holder operable to hold management information for managing the recorded data; and

a detector operable to detect a problem which occurs in processing performed from after the demodulating of the scrambled data by said first demodulator until the retrieving of the AV data,

wherein, in the case where said detector detects the problem during recording of data by said recorder, said recording controller is operable to identify a cause of the problem that has been detected, and to write, into the management information, identified cause, a time at which the recording is started, and a time at which the problem occurred.

22. A digital broadcast recording method comprising: demodulating received scrambled data using information including a designated frequency, and outputting the demodulated scrambled data;

descrambling the scrambled data demodulated in said demodulating, and outputting an MPEG-2 transport stream;

retrieving, from the MPEG-2 transport stream outputted in said descrambling, AV data and a file system which makes up an application;

executing the application made up by the file system;

controlling recording according to a record request received from the executed application;

recording the retrieved AV data according to an instruction given in said controlling; and

detecting a problem which occurs in processing performed from after the demodulation of the scrambled data in said demodulating until said retrieving of the AV data,

wherein, in said controlling, cause of the problem that has been detected is identified, and the identified cause, a time at which the recording of data in said recording is started, and a time at which the problem occurred are

written into management information for managing the recorded data, in the case where, in said detecting, the problem is detected during the recording of data in said recording.

\* \* \* \* \*