

US00RE42567E

(19) **United States**
(12) **Reissued Patent**
Hodges et al.

(10) **Patent Number:** **US RE42,567 E**
(45) **Date of Reissued Patent:** **Jul. 26, 2011**

(54) **ELECTROCHEMICAL CELL**

(75) Inventors: **Alastair M. Hodges**, Blackburn South (AU); **Thomas W. Beck**, North Richmond (AU); **Oddvar Johansen**, Somerville (AU); **Ian Andrew Maxwell**, Five Dock (AU)

(73) Assignee: **LifeScan, Inc.**, Milpitas, CA (US)

(21) Appl. No.: **12/899,342**

(22) Filed: **Oct. 6, 2010**

Related U.S. Patent Documents

Reissue of:

(64) Patent No.: **7,431,814**
Issued: **Oct. 7, 2008**
Appl. No.: **10/843,956**
Filed: **May 12, 2004**

U.S. Applications:

(63) Continuation of application No. 09/840,624, filed on Apr. 23, 2001, now Pat. No. 6,863,801, which is a continuation of application No. 09/709,968, filed on Nov. 10, 2000, now Pat. No. 6,521,110, which is a continuation of application No. 09/314,251, filed on May 18, 1999, now Pat. No. 6,174,420, which is a continuation-in-part of application No. 09/068,828, filed on Mar. 15, 1999, now Pat. No. 6,179,979, and a continuation-in-part of application No. 08/852,804, filed on May 7, 1997, now Pat. No. 5,942,102.

(30) **Foreign Application Priority Data**

Nov. 16, 1995 (AU) PN6619
Nov. 15, 1996 (AU) PCT/AU96/00724

(51) **Int. Cl.**
G01N 27/327 (2006.01)

(52) **U.S. Cl.** **204/403.02; 204/403.04**

(58) **Field of Classification Search** 204/403.01-403.15; 205/777.5, 205/778, 792; 422/401; 439/59-62; 200/511, 200/512, 514
See application file for complete search history.

(56) **References Cited**

U.S. PATENT DOCUMENTS

4,053,381 A 10/1977 Hamblen et al.
4,076,596 A 2/1978 Connery et al.
(Continued)

FOREIGN PATENT DOCUMENTS

AU A 54873/94 2/1993
(Continued)

OTHER PUBLICATIONS

JPO computer generated English language translation of Japanese Patent Application Publication 2001-281219, downloaded on Feb. 28, 2011.*

(Continued)

Primary Examiner — Alex Noguerola

(74) *Attorney, Agent, or Firm* — Nutter McClennen & Fish LLP

(57) **ABSTRACT**

A biosensor for use in determining a concentration of a component in an aqueous liquid sample is provided including: an electrochemical cell having a first electrically resistive substrate having a thin layer of electrically conductive material, a second electrically resistive substrate having a thin layer of electrically conductive material, the substrates being disposed with the electrically conductive materials facing each other and being separated by a sheet including an aperture, the wall of which aperture defines a cell wall and a sample introduction aperture whereby the aqueous liquid sample may be introduced into the cell; and a measuring circuit.

14 Claims, 3 Drawing Sheets

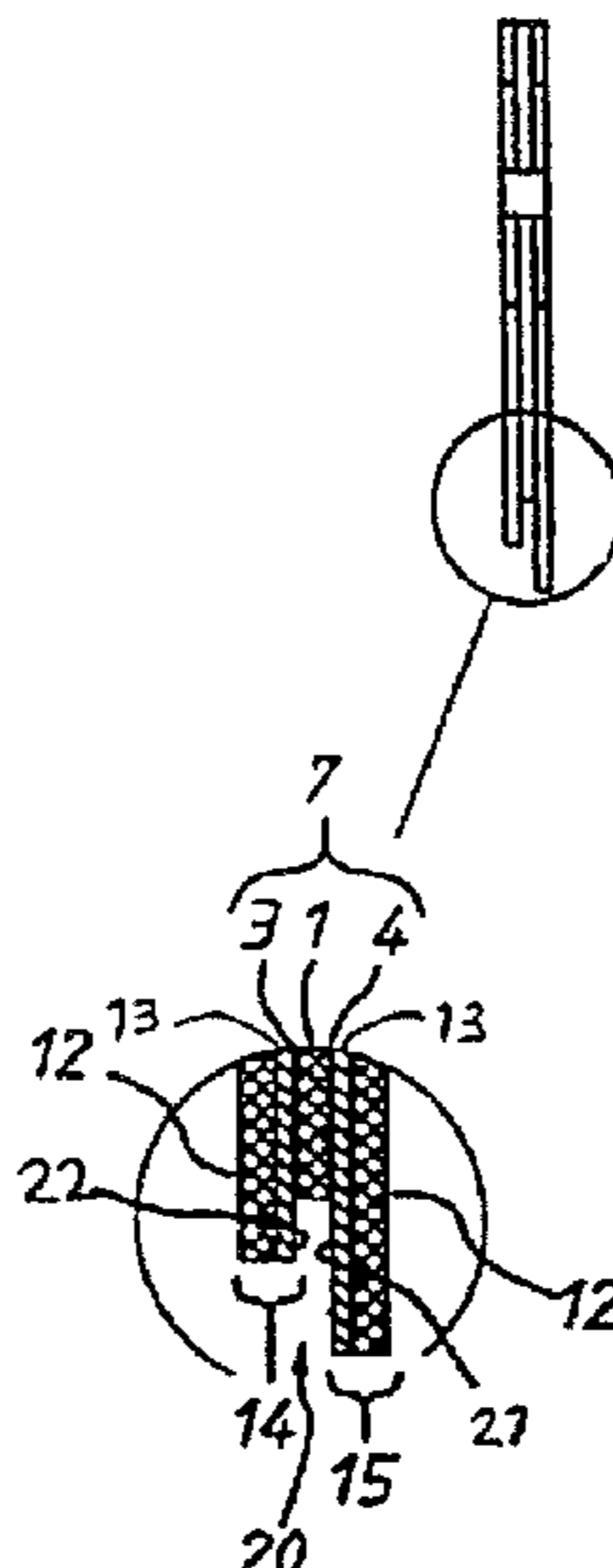

US RE42,567 E

Page 2

U.S. PATENT DOCUMENTS					
4,088,448	A	5/1978 Lilja et al.	5,496,453	A	3/1996 Uenoyama et al.
4,224,125	A	9/1980 Nakamura et al.	5,508,171	A	4/1996 Walling et al.
4,233,029	A	11/1980 Columbus	5,509,410	A	4/1996 Hill et al.
4,254,083	A	3/1981 Columbus	5,512,159	A	4/1996 Yoshioka et al.
4,254,546	A	3/1981 Ullery, Jr.	5,517,313	A	5/1996 Colvin, Jr.
4,259,165	A	3/1981 Miyake	5,518,590	A	5/1996 Fang
4,301,412	A	11/1981 Hill et al.	5,520,787	A	5/1996 Hanagan et al.
4,301,414	A	11/1981 Hill et al.	5,527,446	A	6/1996 Kosek et al.
4,303,887	A	12/1981 Hill et al.	5,567,302	A	10/1996 Song et al.
4,307,188	A	12/1981 White	5,575,895	A	11/1996 Ikeda et al.
4,319,969	A	3/1982 Oda et al.	5,607,565	A	3/1997 Azarnia et al.
4,374,013	A	2/1983 Enfors	5,611,908	A	3/1997 Matthiessen et al.
4,404,065	A	9/1983 Matson	5,620,579	A	4/1997 Genshaw et al.
4,404,066	A	9/1983 Johnson	5,628,890	A	5/1997 Carter et al.
4,431,004	A	2/1984 Bessman et al.	5,645,709	A	7/1997 Birch et al.
4,431,507	A	2/1984 Nankai et al.	5,651,869	A	7/1997 Yoshioka et al.
4,508,613	A	4/1985 Busta et al.	5,682,884	A	11/1997 Hill et al.
4,511,659	A	4/1985 Matson	5,695,947	A	12/1997 Guo et al.
4,517,287	A	5/1985 Scheibe et al.	5,707,502	A	1/1998 McCaffrey et al.
4,517,291	A	5/1985 Seago	5,726,565	A	3/1998 Uchiyama et al.
4,533,440	A	8/1985 Kim	5,727,548	A	3/1998 Hill et al.
4,545,382	A	10/1985 Higgins et al.	5,762,770	A	6/1998 Pritchard et al.
4,552,840	A	11/1985 Riffer	5,849,174	A	12/1998 Sanghera et al.
4,554,064	A	11/1985 McClintock et al.	5,858,188	A	1/1999 Soane et al.
4,591,550	A	5/1986 Hafeman et al.	5,863,400	A	1/1999 Drummond et al.
4,629,563	A	12/1986 Wrasidlo	5,909,114	A	6/1999 Uchiyama et al.
4,654,197	A	3/1987 Lilja et al.	5,942,102	A	8/1999 Hodges et al.
4,664,119	A	5/1987 Bessman et al.	5,997,817	A	12/1999 Crismore et al.
4,711,245	A	12/1987 Higgins et al.	6,071,391	A	6/2000 Gotoh et al.
4,774,039	A	9/1988 Wrasidlo	6,117,289	A	9/2000 Yamamoto et al.
4,782,265	A	11/1988 Schaper et al.	6,153,069	A	11/2000 Pottgen et al.
4,790,925	A	12/1988 Miller et al.	6,174,420	B1	1/2001 Hodges et al.
4,897,173	A	1/1990 Nankai et al.	6,179,979	B1	1/2001 Hodges et al.
4,900,424	A	2/1990 Birth et al.	6,193,873	B1	2/2001 Ohara et al.
4,911,794	A	3/1990 Parce et al.	6,214,205	B1	4/2001 Willner et al.
4,919,770	A	4/1990 Preidel et al.	6,218,134	B1	4/2001 Yamauchi et al.
4,963,815	A	10/1990 Hafeman	6,251,260	B1	6/2001 Heller et al.
4,988,429	A	1/1991 Matthiessen et al.	6,270,637	B1	8/2001 Crismore et al.
4,989,452	A	2/1991 Toon et al.	6,284,125	B1	9/2001 Hodges et al.
5,059,908	A	10/1991 Mina	6,325,973	B1	12/2001 Leland et al.
5,064,516	A	11/1991 Rupich	6,413,395	B1	7/2002 Bhullar et al.
5,089,112	A	2/1992 Skotheim et al.	6,413,410	B1	7/2002 Hodges et al.
5,089,320	A	2/1992 Straus et al.	6,461,496	B1	10/2002 Feldman et al.
5,095,407	A	3/1992 Kanazawa et al.	6,503,381	B1	1/2003 Gotoh et al.
5,108,564	A	4/1992 Szuminsky et al.	6,521,110	B1	2/2003 Hodges et al.
5,120,420	A	6/1992 Nankai et al.	6,521,260	B1	2/2003 Staniforth
5,122,244	A	6/1992 Hoenes et al.	6,544,212	B2	4/2003 Galley et al.
5,126,034	A	6/1992 Carter et al.	6,780,756	B1	8/2004 Farber et al.
5,128,015	A	7/1992 Szuminsky et al.	6,863,801	B2	3/2005 Hodges et al.
5,141,868	A	8/1992 Shanks et al.	7,431,814	B2	10/2008 Hodges et al.
5,151,166	A	9/1992 Harral et al.	7,604,722	B2	10/2009 Hodges et al.
5,156,972	A	10/1992 Issachar et al.	7,608,175	B2	10/2009 Hodges et al.
5,171,689	A	12/1992 Kawaguri et al.	2002/0012943	A1	1/2002 Fowlkes et al.
5,192,415	A	3/1993 Yoshioka et al.			
5,194,133	A	3/1993 Clark et al.			
5,229,282	A	7/1993 Yoshioka et al.			
5,243,516	A	9/1993 White			
5,243,526	A	9/1993 Ito et al.			
5,269,903	A	12/1993 Ikariyama et al.			
5,272,087	A	12/1993 El Murr et al.			
5,282,950	A	2/1994 Dietze et al.			
5,288,636	A	2/1994 Pollmann et al.			
5,312,590	A	5/1994 Gunasingham			
5,314,605	A	5/1994 Matthiessen et al.			
5,320,732	A	6/1994 Nankai et al.			
5,354,447	A	10/1994 Uenoyama et al.			
5,366,609	A	11/1994 White et al.			
5,382,346	A	1/1995 Uenoyama et al.			
5,384,028	A	1/1995 Ito			
5,385,846	A	1/1995 Kuhn et al.			
5,388,163	A	2/1995 Elko et al.			
5,393,399	A	2/1995 Van den Berg et al.			
5,395,504	A	3/1995 Saurer et al.			
5,399,256	A	3/1995 Bohs et al.			
5,405,511	A	4/1995 White et al.			
5,413,690	A	5/1995 Kost et al.			
5,437,999	A	8/1995 Diebold et al.			
5,443,710	A	8/1995 Broderick			

FOREIGN PATENT DOCUMENTS

AU	3104293	A	7/1993
AU	A 31042/93		7/1993
AU	5487394	A	8/1994
CN	1325908		12/2001
DE	3103 464		8/1982
DE	3103464	A1	8/1982
DE	29709141		8/1997
EM	0127958	A2	12/1984
EP	0125137		11/1984
EP	0125137	A2	11/1984
EP	0 170 375		2/1986
EP	0170375	A2	2/1986
EP	0170375	B1	2/1986
EP	0251915	A2	1/1988
EP	0255291	A1	2/1988
EP	0 266 204	A2	4/1988
EP	0266204	A2	5/1988
EP	0278647	A2	8/1988
EP	0290770		11/1988
EP	0290770	A2	11/1988
EP	0299779	A2	1/1989
EP	0359 831	A1	10/1989
EP	0351516	A2	1/1990
EP	0351891	A2	1/1990

US RE42,567 E

Page 3

EP	0351892	A2	1/1990
EP	0359831	A1	3/1990
EP	0 171 375	A1	5/1990
EP	0367432		5/1990
EP	0367432	A1	5/1990
EP	0 400 918	A1	12/1990
EP	0400918		12/1990
EP	0406304	A1	1/1991
EP	0406304	B1	1/1991
EP	0418404	A1	3/1991
EP	0 422 708		4/1991
EP	0451981	A2	10/1991
EP	0 127 958 (A2)		3/1992
EP	0560336	A1	9/1993
EP	0593096		4/1994
EP	593096	A2	4/1994
EP	0603954		6/1994
EP	0603954	A	6/1994
EP	0609760	A1	8/1994
EP	0359831		8/1995
EP	0735303		10/1996
EP	0735303	A1	10/1996
EP	0741186		11/1996
EP	0764469		3/1997
EP	0964059		12/1999
EP	0 585 933		12/2005
GB	2020424	A	11/1979
GB	2154735	A	9/1985
GB	2194112		2/1988
GB	2 201248		8/1988
GB	2201248	A	8/1988
GB	2215846		9/1989
GB	2215846	A	9/1989
GB	2 235 050	A	2/1991
GB	2235050	A	2/1991
JP	54006595		1/1979
JP	59003345	A	1/1984
JP	60017344		1/1985
JP	60-250246		12/1985
JP	60244853		12/1985
JP	60250246		12/1985
JP	61-002060		1/1986
JP	61002060		1/1986
JP	62228274		10/1987
JP	63139246		6/1988
JP	63317097	A	12/1988
JP	01-253648		10/1989
JP	1253648	A	10/1989
JP	01-294453		11/1989
JP	1294453		11/1989
JP	3107747	A	5/1991
JP	3-167464		7/1991
JP	3167464	A	7/1991
JP	4062463	A	2/1992
JP	4-66112		3/1992
JP	4066112		3/1992
JP	4340453	A	11/1992
JP	04343065		11/1992
JP	04343065	A	11/1992
JP	05002007		1/1993
JP	5002007	A	1/1993
JP	05-80018		3/1993
JP	5080018		3/1993
JP	5256812	A	10/1993
JP	5312760	A	11/1993
JP	5312761	A	11/1993
JP	H5-312761		11/1993
JP	6150262	A	5/1994
JP	6222874		8/1994
JP	6224140	A	8/1994
JP	06-310746		11/1994
JP	6310746		11/1994
JP	08062179		3/1996
JP	8062179	A	3/1996
JP	8304340		11/1996
JP	08304340		11/1996
JP	09-222408		8/1997
JP	9222408		8/1997
JP	09-236570		9/1997

JP	09-243588		9/1997
JP	9236570		9/1997
JP	9243588		9/1997
JP	2001281219	A	10/2001
JP	2007225619		9/2007
RU	2 046 361	C1	10/1995
SU	1351627		11/1987
SU	1351627A	A2	11/1987
SU	1806187		3/1993
WO	WO89/08713		9/1989
WO	WO-8908713	A1	9/1989
WO	9005910		5/1990
WO	WO-900591	A1	5/1990
WO	9109139		6/1991
WO	WO-9109139	A1	6/1991
WO	WO-92/15701		9/1992
WO	WO-9215701	A1	9/1992
WO	WO-94/02842		2/1994
WO	WO-9402842	A1	2/1994
WO	WO-94/29731		12/1994
WO	WO-9429731	A1	12/1994
WO	WO-95/16198		6/1995
WO	WO-9516198	A1	6/1995
WO	WO-9521934		8/1995
WO	WO95/28634		10/1995
WO	WO-9528634	A1	10/1995
WO	WO97/00441		1/1997
WO	WO-9700441	A1	1/1997
WO	WO-97/18464		5/1997
WO	WO-97/18464	A1	5/1997
WO	WO-97/18465		5/1997
WO	WO-9718465	A1	5/1997
WO	WO-9811426		3/1998
WO	WO-98/11426		9/1998
WO	WO-98/43073		10/1998
WO	WO-98/43074		10/1998
WO	WO-98/43074	A1	10/1998
WO	WO-9946585		9/1999
WO	WO-0020626	A1	4/2000
WO	WO-0208763		1/2002

OTHER PUBLICATIONS

Patent family history and equivalent filings for WO 97/00441 A1 downloaded from Derwent on Mar. 4, 2011.*

Chinese Office Action (Application No. CN200610100717.9) dated Dec. 5, 2008.

Japanese Office Action (Application No. 102675/2007) dated Jan. 8, 2010.

Japanese Office Action for Japanese Application No. 2003-535271 dated Jun. 29, 2010 (3 pages).

Japanese Office Action (Application No. 2003-535271) dated Jul. 28, 2008, 7 pages.

Anderson, et al., *Diagnostic Criteria for the Study of Chemical and Physical Processes by Twin-Electrode Thin-Layer Electrochemistry*, *J. Electroanalytical Chemistry*; vol. 12, 1966, pp. 477-494.

Anderson, et al., *Thin-Layer Electrochemistry: Steady-State Methods of Studying Rate Processes*, *J. Electroanalytical Chemistry*; vol. 10, 1965, pp. 295-305.

Cassidy, et al.; *Novel Electrochemical Device for the Detection of Cholesterol or Glucose*, *Analyst*, vol. 118; Apr. 1993; pp. 415-418.

Chidsey, et al., *Micrometer-Spaced Platinum Interdigitated Array Electrode: Fabrication, Theory, and Initial Use*, *Analytical Chemistry*, vol. 58, No. 3, Mar. 1986, pp. 801-807.

Christensen, et al. *Chronopotentiometry in Thin Layer of Solution*, *Analytical Chemistry*, vol. 35, No. 2, 1963, pp. 205-209.

Daruhazi, et al., "Cyclic Voltammetry for Reversible Redox-Electrode Reaction in Thin Layer Cells with Closely Separated Working and Auxiliary Electrodes of the Same Size", in *J. Electroanal. Chem.* 264; 77-89 (1989).

Denuault, et al., *Direct Determination of Diffusion-Coefficients by Chronoamperometry at Microdisk Electrodes*, *Journal of Electroanalytical Chemistry*, vol. 308, No. 1-2, 1991, pp. 27-38.

Enthone—*Imaging Technologies Update Jun. 2001/No. 3.*

European Search Report for App. No. 96 93 7919 apparently published Jan. 24, 2001.

- European Search Report for App. No. 99 20 2305 apparently published May 23, 2001.
- European Search Report for App. No. 03 00 7604 dated May 19, 2003.
- Hall, E., *Biosensors*, Chapter 5: "Amperometric Assay Techniques", 1990.
- Hubbard, et al., *New Electrodes for Chronopotentiometry in Thin Layers of Solution*, *Analytical Chemistry*, vol. 36, No. 4, Apr. 1964, pp. 723-728.
- Hubbard, et al., *The Theory and Practice of Electrochemistry with Thin Layer Cells*, in *Electroanalytical Chemistry*, (Bard, Ed.), Marcel Dekker, New York, 1970, vol. 4 (pp. 129-214).
- Hubbard, *Study of the Kinetics of Electrochemical Reactions by Thin-Layer Voltammetry*, *J. Electroanalytical Chemistry*, vol. 22, 1969, pp. 165-174.
- International Search Report PCT/US02/31289 dated Jul. 18, 2003.
- Jung, et al., *Simultaneous Determination of Diffusion Coefficient and Concentration by Chronoamperometry at a Microdisk Electrode*, *Bull Korean Chem. Soc.*; 1004, V. 15, No. 3, pp. 209-213 1994.
- McDuffie, et al., *Twin electrode thin-Layer Electrochemistry*, *Analytical Chemistry*, vol. 38, No. 7, Jun. 1966; pp. 883-890.
- Morris, et al., *Electrochemistry at Pt Band Electrodes of Width Approaching Molecular Dimensions, Breakdown of Transport Equations at Very Small Electrodes*, *J. of Physical Chemistry*, vol. 91, No. 13, 1987, pp. 3559-3564.
- Nicholson, et al., *Theory of Stationary Electrode Polarography*, *Analytical Chemistry*; vol. 36, No. 4, Apr. 1964, pp. 706-723.
- Niwa, et al., *Electrochemical Behavior of Reversible Redox Species at Interdigitated Array Electrodes with Different Geometries: Consideration of Redox Cycling and Collection Efficiency*, *Analytical Chemistry*; Mar. 1990, vol. 62, No. 5, pp. 447-452.
- Niwa, et al., *Highly Selective electrochemical Detection of Dopamine Using Interdigitated Array of Electrodes Modified with Nafion/Polyester Ionomer Layered Film*, *Electroanalysis*, vol. 6, No. 3, Mar. 1994, pp. 237-243, XP000943528.
- Oglesby, et al., *Thin Layer Electrochemical Studies Using Controlled Potential or Controlled Current*, *Analytical Chemistry*, vol. 37, No. 11, Oct. 1965, pp. 1312-1316.
- Paeschke, et al., *Dynamic Redox Recycling of Cytochrome C*, *Journal of Electroanalytical Chemistry*; vol. 393, No. 1/02, 1995, pp. 131-135.
- Paeschke, et al., *Properties of Interdigital Electrode Arrays With Different Geometries*, *Analytical Chimica Acta*; vol. 305, No. 1/03, 1995, pp. 126-136.
- Yaoita, M. et al., *"Pulse Chronoamperometric Technique of Enzyme Embodied Electrode Applied to Glucose Measurement in Whole Serum"*, *Extended Abstracts, US Electrochemical Society*, Princeton, NJ; vol. 93/1, 1993, p. 2801.
- Hall, E., *Biosensors*, Chapter 5: "Amperometric Assay Techniques", 1990.
- Denuault, G. et al., *"Direct Determination of Diffusion-Coefficients by Chronoamperometry at Microdisk Electrodes"*, *Journal of Electroanalytical Chemistry*, vol. 308, No. 1-2, 1991, pp. 27-38.
- Seddon, B. J., et al., *"Preparation and Amperometric Response of Carbon and Platinum Dual Cylinder Microelectrodes"*, *Electrochimica Acta*, vol. 40, No. 4, Mar. 1, 1995, pp. 455-465.
- Derwent Abstracts Accession No. 92 119462/15, Class S03, JP, A, 04-62463 (Tokyo Yogyo K.K.) Feb. 27, 1992. Patent Abstracts of Japan.
- Patent Abstracts of Japan, p.-269, p. 168, JP, A, 59-3345, (Hitachi Seisakusho K.K.) Jan. 10, 1994.
- Laszlo Daruhazi et al., *"Cyclic Voltammetry for Reversible Redox-Electrode Reaction in Thin Layer Cells with Closely Separated Working and Auxiliary Electrodes of the Same Size"*, in *J. Electroanal. Chem.* 264: 77-89 (1989).
- (Abstract Only) Kobayashi Yoshiaki et al., *Biosensor*; JP 61002060, A; Jan. 3, 1986.
- European Search Report, Application No. 96937919.
- European Search Report, Application No. EP 99202305.
- JPO Patent Abstract of JP-04-56112-A.
- Patent Abstract of Japan, Publication No. 60250246, published Dec. 10, 1985.
- Abstract for JP 6310746 A; To: Miyahara et al.
- Hubbard, et al., *The Theory and Practice of Electrochemistry with Thin Layer Cells*, *Electroanalytical Chemistry*, (Bard, Ed.), Marcel Dekker, New York, 1970, vol. 4., pp. 129-214.
- Specification sheet from Adhesives Research, Inc. Arclad® 8314 (May 2, 1997) (1 pg.).
- Specification sheet for Adhesives Research, Inc., ARCare® 7148, double-sided adhesive coated polyester film (Mar. 30, 1995) (2 pages).
- Trojanek, et al., *Data processing in reaction rate measurements*, *Collect. Czech. Chem Commun.*, 38(9):2572-2580, 1973.
- Uchiyama, et al., *Measurement Of Homogeneous Reaction Rate By Concentration-Step, Controlled Potential Electrolysis*, *J. Electroanal. Chem Interfacial Electrochem.*, 91(3):301-308, 1978.
- Vidal, et al., *A chronoamperometric sensor for hydrogen peroxide based on electro transfer between immobilized horseradish peroxidase on a glossy carbon electrode and a diffusing ferrocene mediator*, *Sensors and Actuators, B, Ch*, Elsevier Sequoia S.A., Lausanne, vol. 21, No. 2 (Aug. 1, 1994), pp. 135-141.
- Yaoita, et al., *Pulse Chronoamperometric Technique of Enzyme Embodied Electrode Applied to Glucose Measurement in Whole Serum*, *Extended Abstracts, US Electrochemical Society*, Princeton, NJ; vol. 93/1, 1993, p. 2801.
- Oglesby et al. *Anal. Chem.* vol. 37, No. 11, Oct. 1965, pp. 1312-1316.*
- (Abstract Only) Miyawaki Akiyoshi et al, *Measurement Using Biosensor*; JP60250246, Dec. 10, 1985.
- John F. Cassidy et al., *"Novel Electrochemical Device for the Detection of Cholesterol or Glucose"* in *Analyst Apr.* 1993, vol. 118, p. 415-418.
- Derwent Abstract Accession No. 93-140898/17, JP, A., 05080018 (Rikagaku Kenkyusho) Mar. 30, 1993.
- Derwent Abstract Accession No. 95-026336/04, JP, A., 06310746 (Hitachi Ltd) Nov. 4, 1994.
- Simultaneous Determination of Diffusion Coefficient and Concentration by Chronoamperometry at a Microdisk Electrode*; Jung et al.; *Bull. Korean Chem. Soc.*, 1994, vol. 15, No. 3, 209-213.
- Diagnostic Criteria For The Study of Chemical And Physical Processes By Twin-Electrode Thin-Layer Electrochemistry*; Anderson et al., *J. Electroanal. Chem.* 12(996)477-494.
- Paeschke, M. et al., *"Dynamic Redox Recycling of Cytochrome C"*, *Journal of Electroanalytical Chemistry*, vol. 393, No. 1/02, 1995, pp. 131-135.
- Paeschke, M. et al., *"Properties of Interdigital Electrode Arrays With Different Geometries"*, *Analytica Chimica Acta*; vol. 305, No. 1/03, 1995, pp. 126-136.
- Yaoita, M. et al., *"Pulse Chronoamperometric Technique of Enzyme Embodied Electrode Applied to Glucose Measurement in Whole Serum"*, *Extended Abstracts, US Electrochemical Society*, Princeton, NJ; vol. 93/1, 1993, p. 2801.
- Hall, E., *Biosensors*, Chapter 5: "Amperometric Assay Techniques", 1990.
- Denuault, G. et al., *"Direct Determination of Diffusion-Coefficients by Chronoamperometry at Microdisk Electrodes"*, *Journal of Electroanalytical Chemistry*, vol. 308, No. 1-2, 1991, pp. 27-38.
- Seddon, B. J., et al., *"Preparation and Amperometric Response of Carbon and Platinum Dual Cylinder Microelectrodes"*, *Electrochimica Acta*, vol. 40, No. 4, Mar. 1, 1995, pp. 455-465.
- Derwent Abstracts Accession No. 92 119462/15, Class S03, JP, A, 04-62463 (Tokyo Yogyo K.K.) Feb. 27, 1992. Patent Abstracts of Japan.
- Patent Abstracts of Japan, p.-269, p. 168, JP, A, 59-3345, (Hitachi Seisakusho K.K.) Jan. 10, 1994.
- Laszlo Daruhazi et al., *"Cyclic Voltammetry for Reversible Redox-Electrode Reaction in Thin Layer Cells with Closely Separated Working and Auxiliary Electrodes of the Same Size"*, in *J. Electroanal. Chem.* 264: 77-89 (1989).
- (Abstract Only) Kobayashi Yoshiaki et al., *Biosensor*; JP 61002060, A; Jan. 3, 1986.
- European Search Report, Application No. 96937919.
- European Search Report, Application No. EP 99202305.
- JPO Patent Abstract of JP-04-56112-A.
- Patent Abstract of Japan, Publication No. 60250246, published Dec. 10, 1985.
- Abstract for JP 6310746 A; To: Miyahara et al.
- Hubbard, et al., *The Theory and Practice of Electrochemistry with Thin Layer Cells*, *Electroanalytical Chemistry*, (Bard, Ed.), Marcel Dekker, New York, 1970, vol. 4., pp. 129-214.
- Specification sheet from Adhesives Research, Inc. Arclad® 8314 (May 2, 1997).
- Niwa, O., et al., *"Electrochemical Behavior of Reversible Redox Species at Interdigitated Array Electrodes with Different Geometries: Consideration of Redox Cycling and Collection"*; *Analytical Chemistry*, Mar. 1990, vol. 62, No. 5.
- Data Sheet for ARcae 7148 double-side adhesive coated polyester film, (Mar. 30, 1995) (2 pp.).
- Reilly, Charles: *"Electrochemistry Using Thin-Layer Cells"*, *Rev. Pure and Appl. Chem.* vol. 18.
- Christensen & Anson; *"Chronopotentiometry in Thin Layers of Solution"*; *Analytical Chemistry*; vol. 35; No. 2, 1963.
- Hubbard & Anson; *"New Electrodes for Chronopotentiometry in Thin Layers of Solutions"*; *Analytical Chemistry*; vol. 36, No. 4, Apr. 1964.
- McDuffie, Anderson, & Reilly; *"Twin Electrode Thin-Layer Electrochemistry"*; *Analytical Chemistry*; vol. 38, No. 7; pp. 883-890, Jun. 1966.

- Morris, Franta and White; "Electrochemistry at Pt Band Electrodes of Width Approaching Molecular Dimensions. Breakdown of Transport Equations at Very Small Electrodes"; *The Journal of Physical Chemistry*; vol. 91, No. 13; 1987.
- Nicholson and Shain; "Theory of Stationary Electrode Polarography"; *Analytical Chemistry*; vol. 36, No. 4, Apr. 1964.
- Pickup Lutner, Leidner, and Murray; "Redox Conduction in Single and bilayer Films of Redox Polymer"; *American Chemical Society*; vol. 106; No. 7; 1984.
- Chidsey, Feldman, Lundgren, and Murray; "Micrometer-Spaced Platinum Interdigitated Array Electrode: Fabrication, Theory, and Initial Use"; *Analytical Chemistry*; vol. 58, No. 3; Mar. 1986.
- Hubbard; "Study of the Kinetics of Electrochemical Reactions by Thin-Layer Voltammetry"; *Journal of Electroanalytical Chemistry*; vol. 22; 1969.
- Anderson and Reilly; "Thin-Layer Electrochemistry: Search-State Methods of Studying Rate Processes"; *J. Electroanal. Chem.*, vol. 10; 1965.
- Abstracts of Jpan; Title: "Electrolyte Analyzer"; Publication No. 08062179A; Mar. 8, 1996.
- Uchiyama et al., Measurement Of Homogeneous Reaction Rate By Concentration-Step, Controlled Potential Electrolysis.; *J. Electroanal. Chem Interfacial Electrochem.*, 91(3):301-308, 1978.
- Trojanek et al., "Data processing in reaction rate measurements," *Collect. Czechoslov. Chem Commun.*, 38(9):2572-2580, 1973.
- O. Niwa, M. Morita, H. Tabei, "Highly Selective Electrochemical Detection of Dopamine Using Interdigital Array of Electrodes Modified with Nafion/Polyester Ionomer Layered Film", *Electroanalysis*, vol. 6, No. 3, Mar. 1994, pp. 237-243, XP000943528.
- J. Salbeck, "Spectrochemical Thin-Layer Cell for Nonaqueous Solvent Systems," *Anal. Chem.*, 1993, vol. 65, pp. 2165-2173.
- Anderson, McDuffie and Reilly; "Diagnostic Criteria for the Study of Chemical and Physical Processes by Twin-Electrode Thin-Layer Electrochemistry"; *Electroanalytical Chemistry*; vol. 12, 1966, pp. 477-494.
- European Search Report No. EP 03007604 dated May 19, 2003.
- Patent Abstracts of Japan, JP A 04-62463.
- Patent Abstracts of Japan JP63-139246 A2 (Jun. 1988).
- Enthone—Imaging Technologies Update Jun. 2001/No. 3) Enplate DSR 3241.
- Vidal, J. C. et al., "A Chronoamperometric Sensor for Hydrogen Peroxide Based on Electron Transfer Between Immobilized Horseradish Peroxidase on a Glassy Carbon Electrode and a Diffusing Ferrocene Mediator", *Sensors and Actuators B:Chemical*, vol. 21, Issue 2, Aug. 1994, pp. 135-141.

* cited by examiner

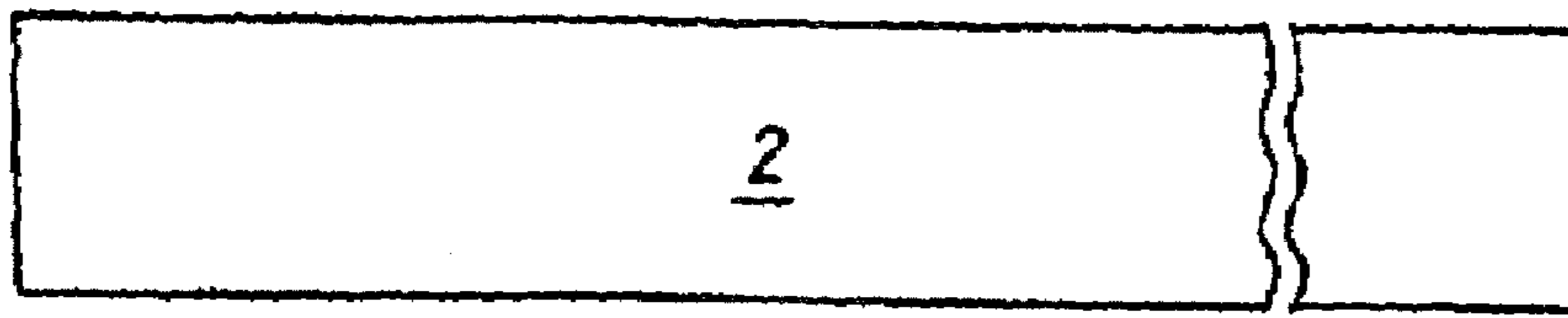

FIG. 1

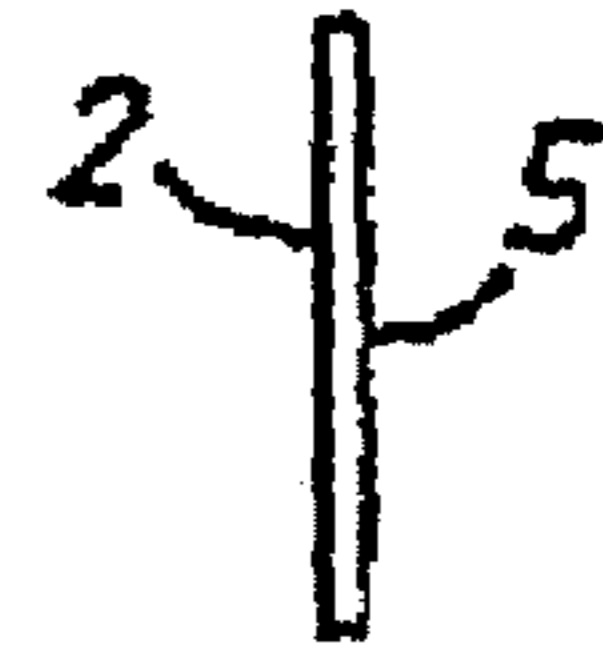

FIG. 3



FIG. 2

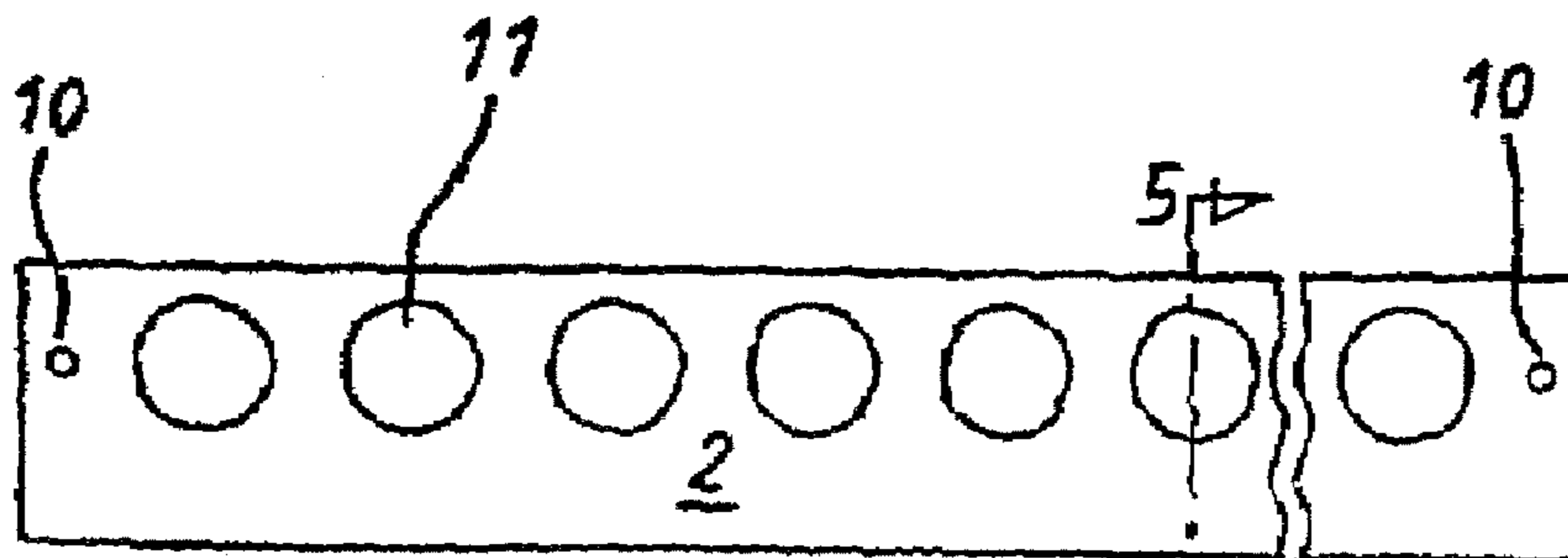
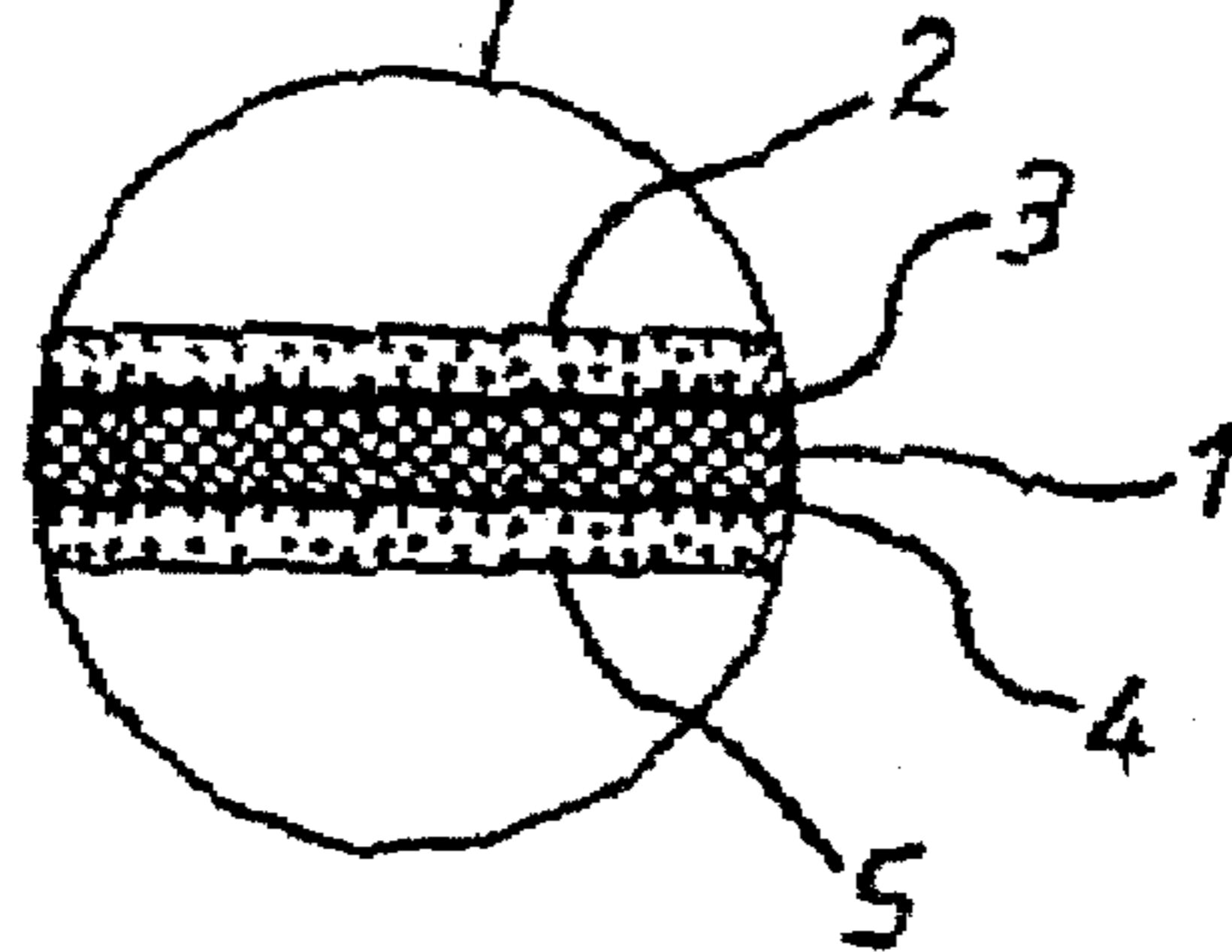

FIG. 4

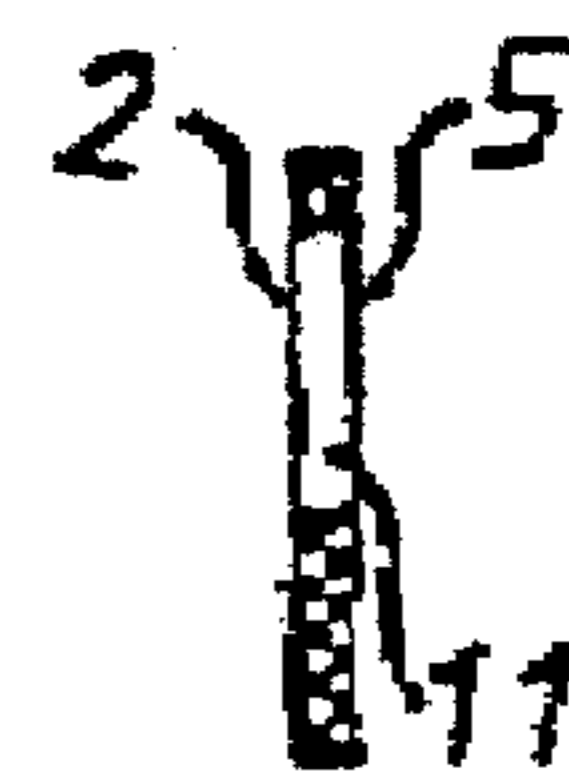

FIG. 5

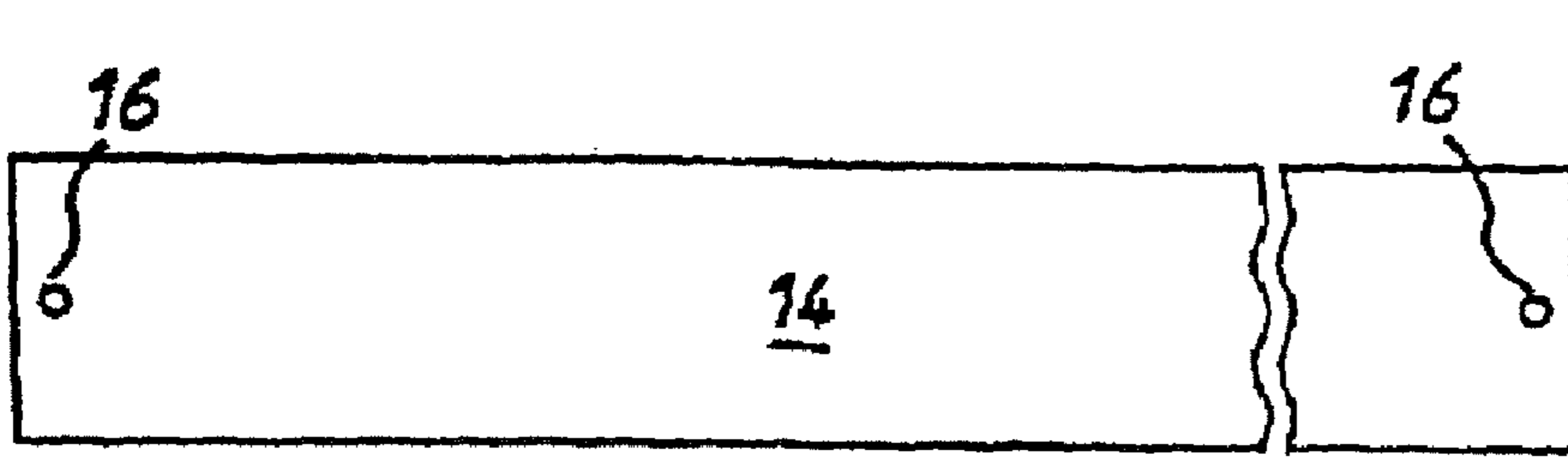

FIG. 6

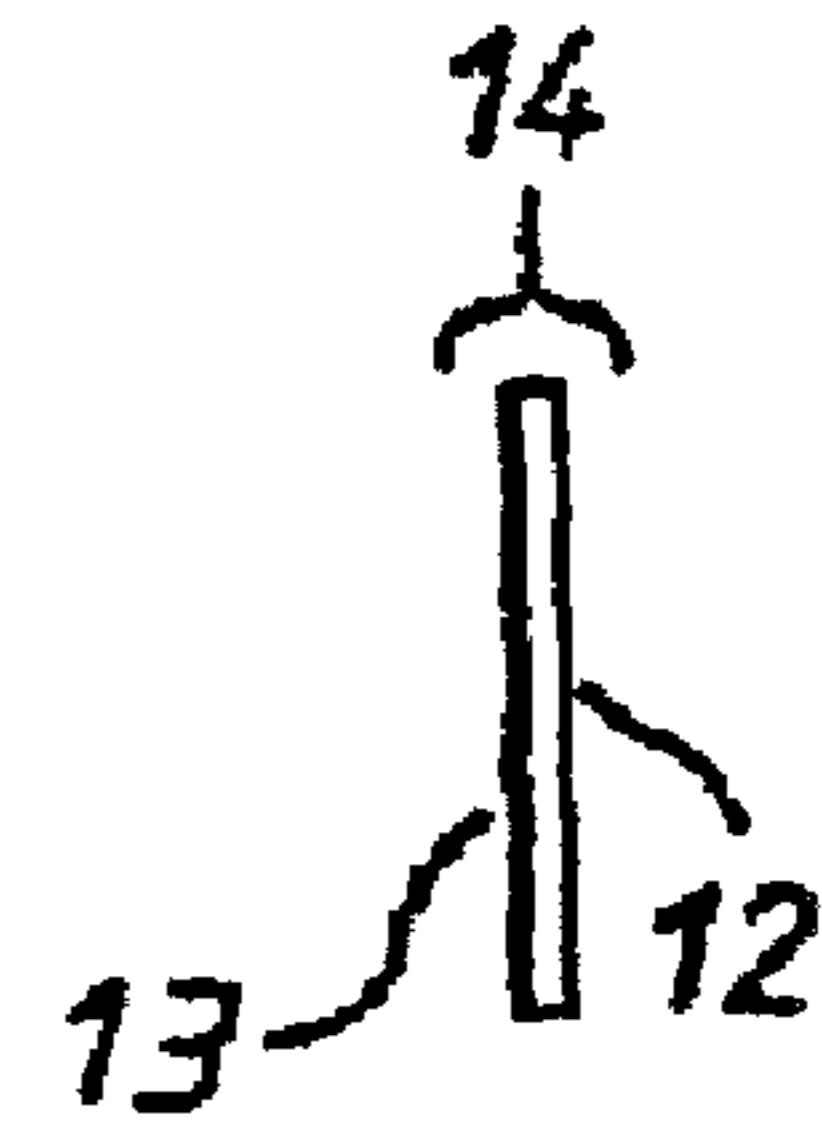

FIG. 8



FIG. 7

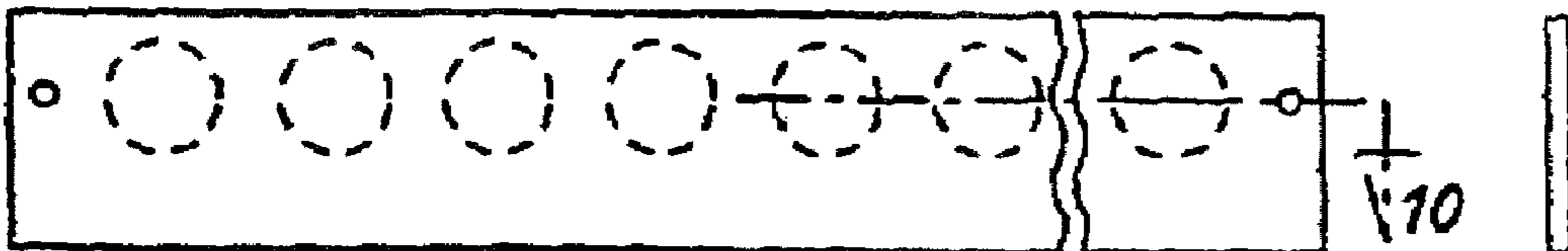
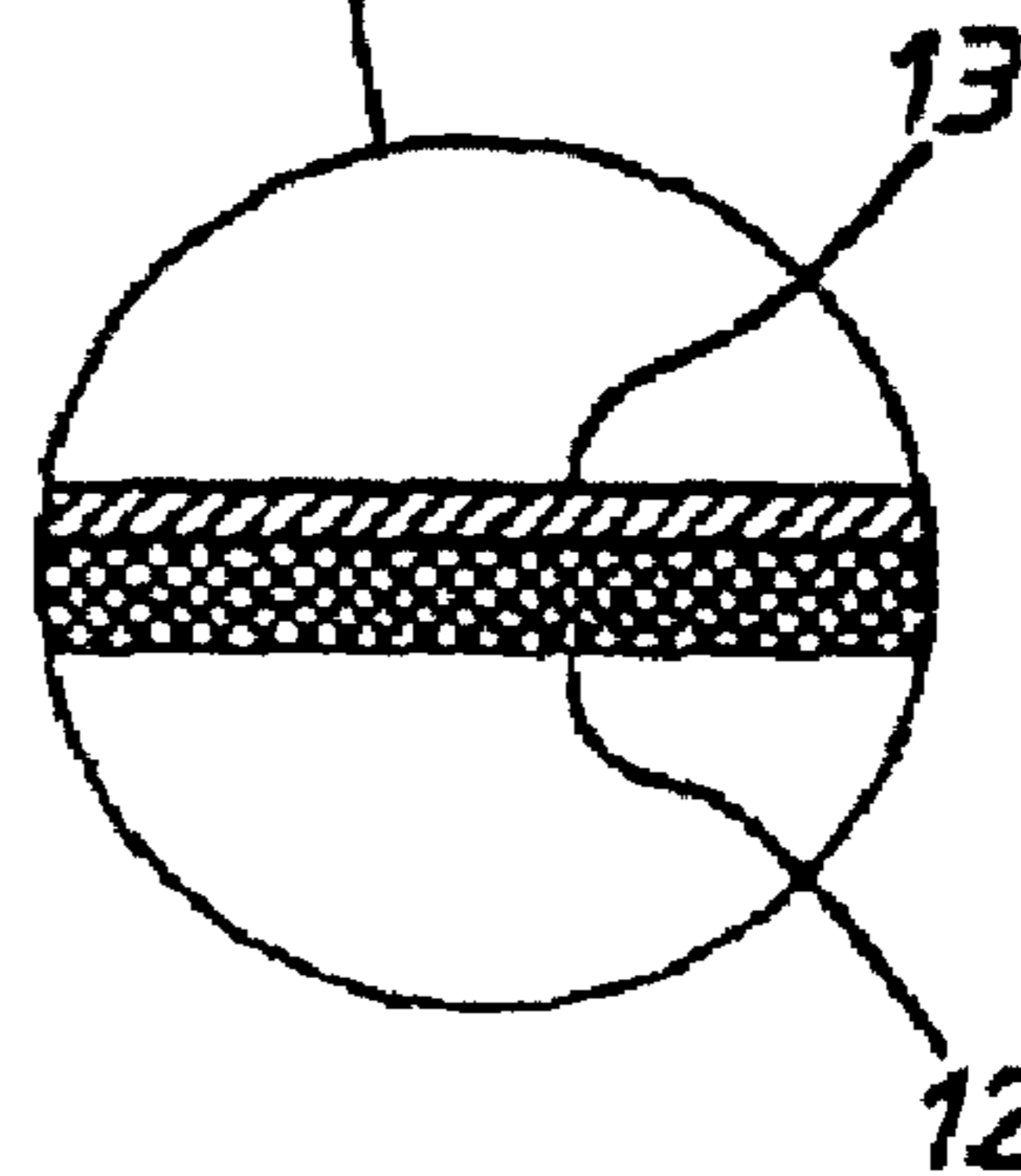
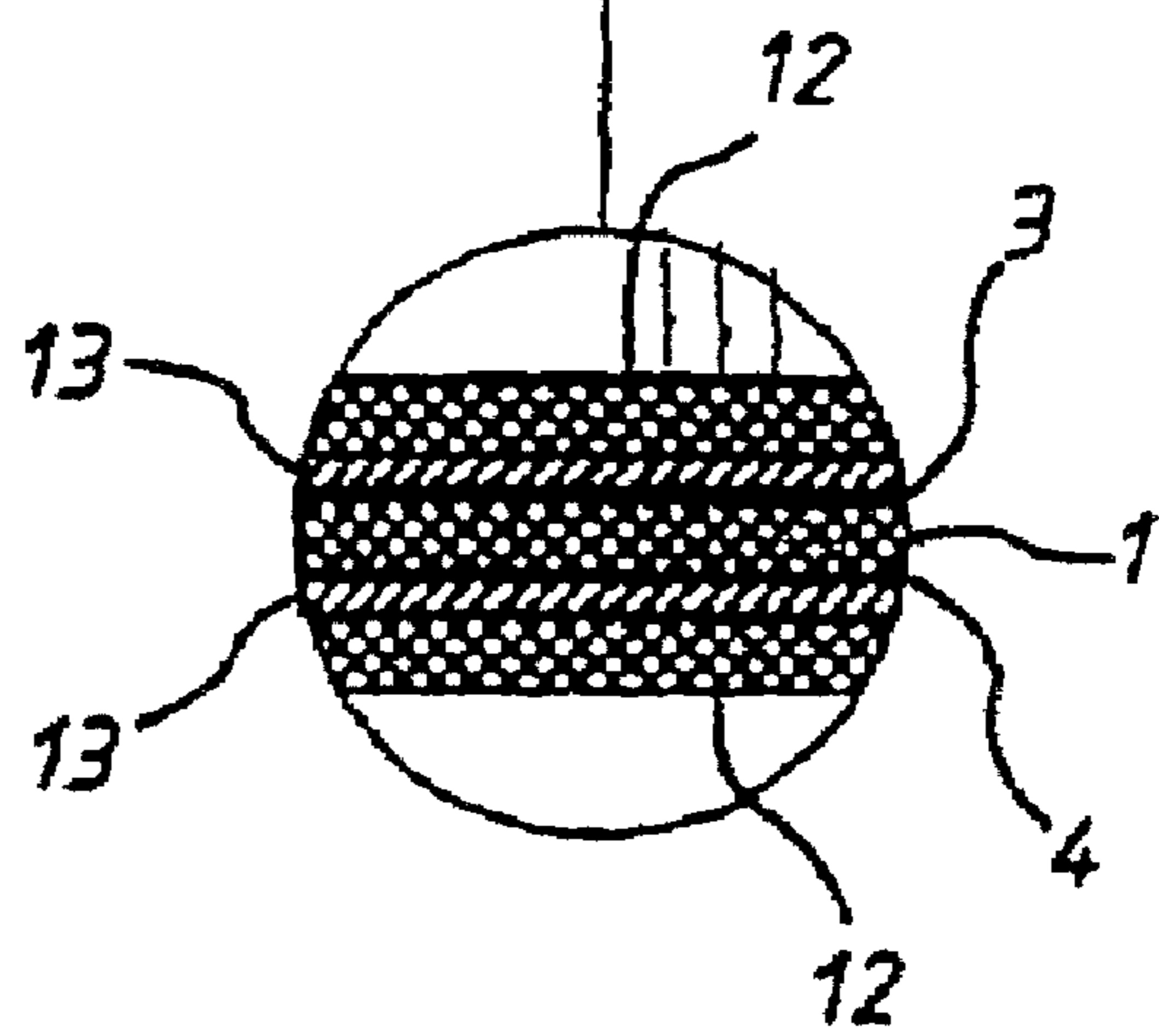

FIG. 9

FIG. 11



FIG. 10



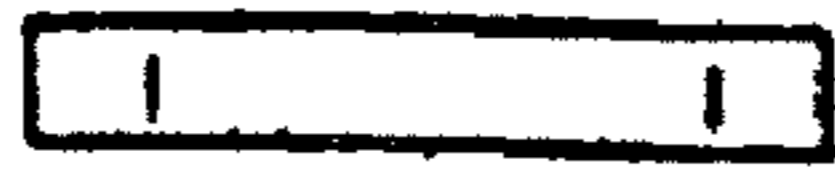

FIG. 13

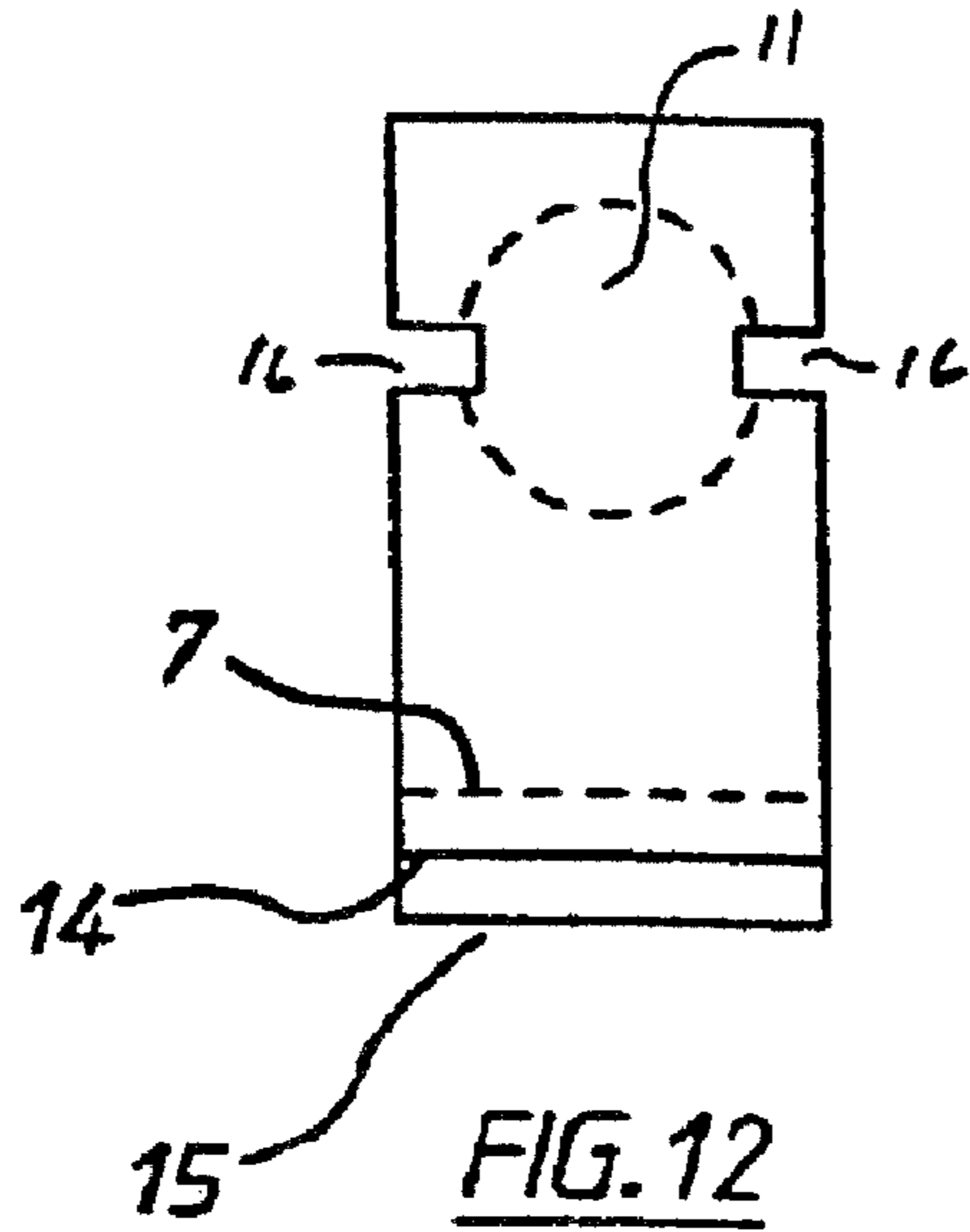

FIG. 12

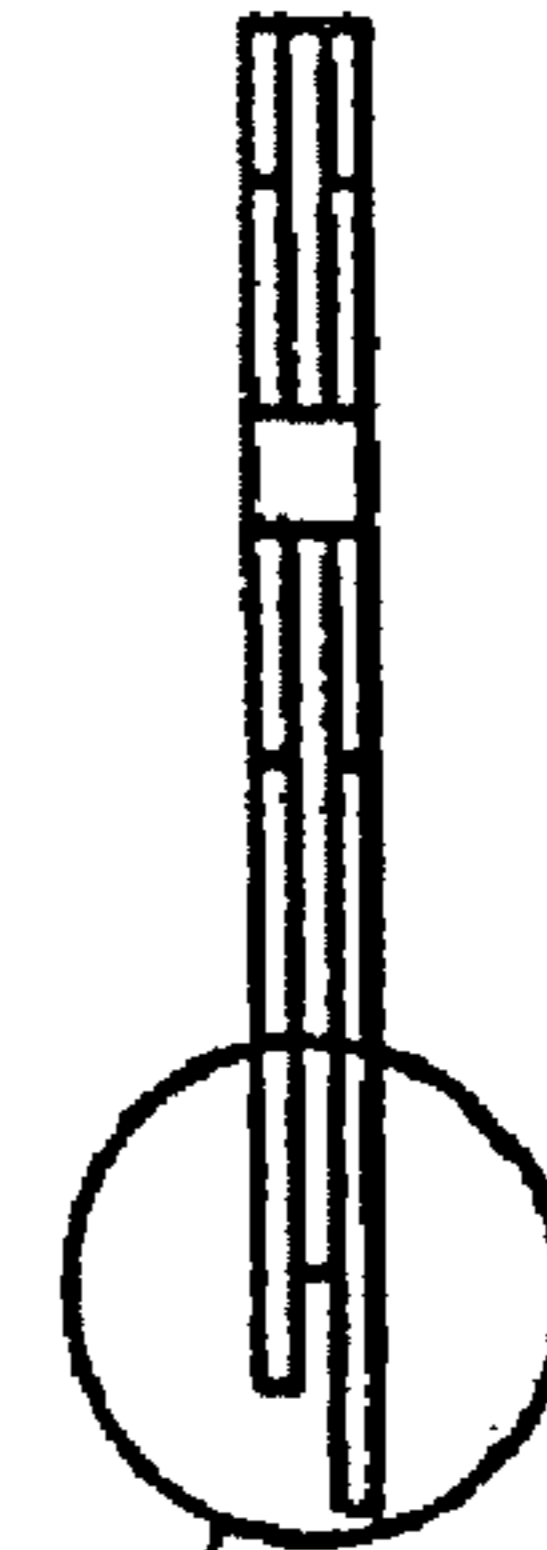

FIG. 14

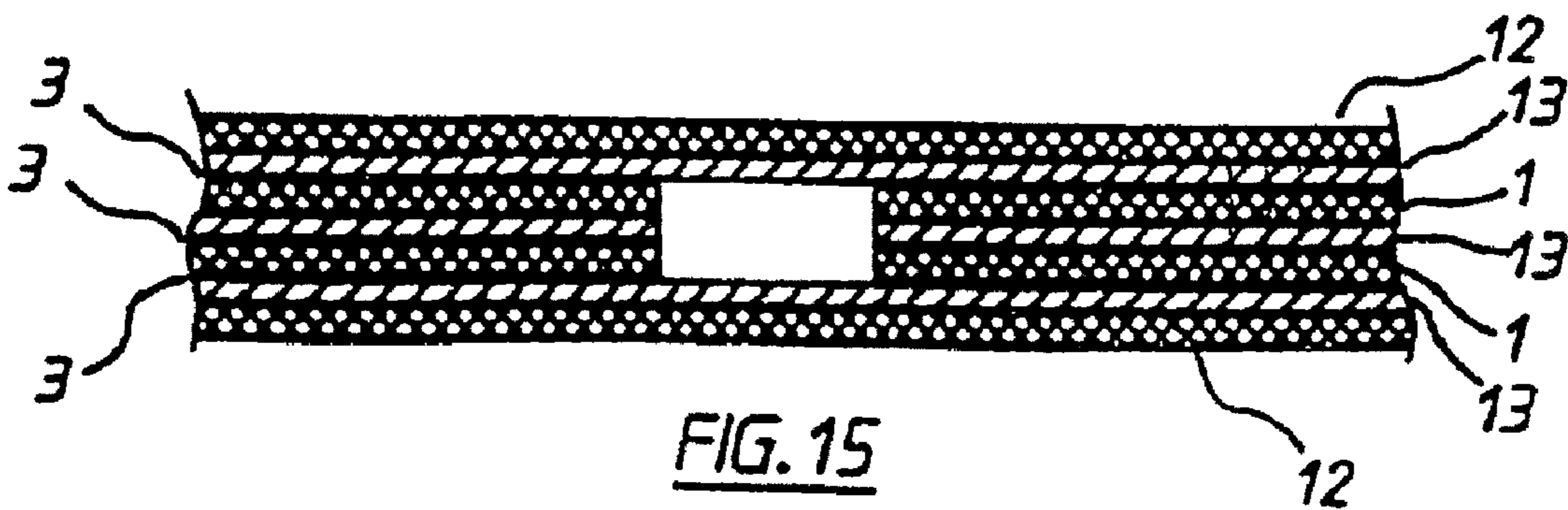
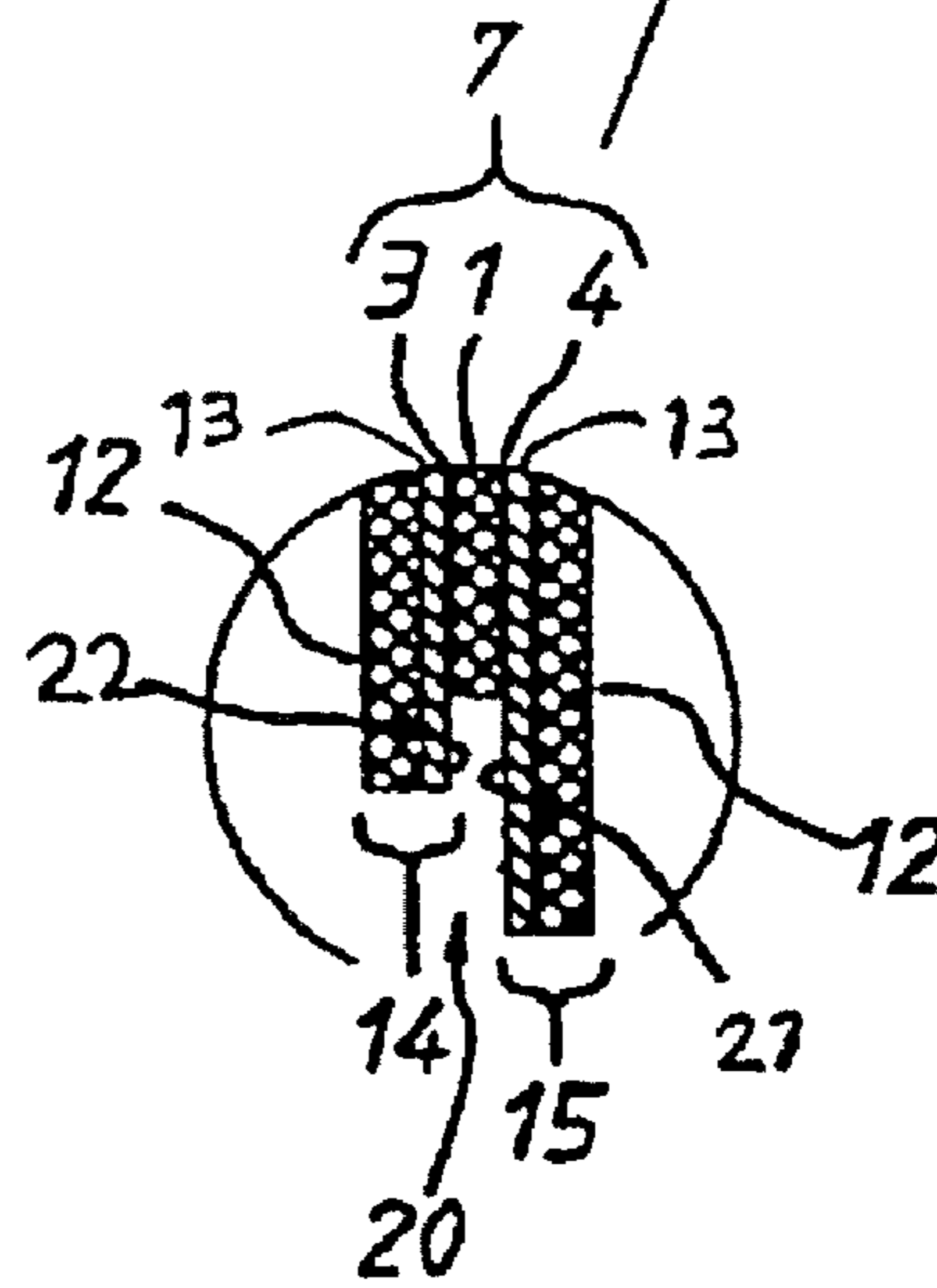

FIG. 15

ELECTROCHEMICAL CELL

Matter enclosed in heavy brackets [] appears in the original patent but forms no part of this reissue specification; matter printed in italics indicates the additions made by reissue.

RELATED APPLICATIONS

This application is a continuation of U.S. patent application Ser. No. 09/840,624 filed on Apr. 23, 2001, which issued as U.S. Pat. No. 6,863,801 on Mar. 8, 2005, which is a continuation of U.S. application Ser. No. 09/709,968, filed Nov. 10, 2000, which issued as U.S. Pat. No. 6,521,110 on Feb. 18, 2003, which is a continuation of U.S. application Ser. No. 09/314,251, filed May 18, 1999, which issued as U.S. Pat. No. 6,174,420 on Jan. 16, 2001, which is a continuation-in-part of U.S. application Ser. No. 09/068,828, filed on Mar. 15, 1999, which issued as U.S. Pat. No. 6,179,979 on Jan. 30, 2001, and is also a continuation-in-part of U.S. application Ser. No. 08/852,804, filed on May 7, 1997, which issued as U.S. Pat. No. 5,942,102 on Aug. 24, 1999, the contents of which are incorporated herein by reference in their entirety.

FIELD OF THE INVENTION

This invention relates to an electrochemical cell for determining the concentration of an analyte in a carrier.

BACKGROUND OF THE INVENTION

The invention herein described is an improvement in or modification of the invention described in our co-pending U.S. application Ser. No. 08/981,385, entitled ELECTROCHEMICAL CELL, filed on Dec. 18, 1997, the contents of which are incorporated herein by reference in its entirety.

The invention will herein be described with particular reference to a biosensor adapted to measure the concentration of glucose in blood, but it will be understood not to be limited to that particular use and is applicable to other analytic determinations.

It is known to measure the concentration of a component to be analysed in an aqueous liquid sample by placing the sample into a reaction zone in an electrochemical cell comprising two electrodes having an impedance which renders them suitable for amperometric measurement. The component to be analysed is allowed to react directly or indirectly with a redox reagent whereby to form an oxidisable (or reducible) substance in an amount corresponding to the concentration of the component to be analysed. The quantity of the oxidisable (or reducible) substance present is then estimated electrochemically. Generally this method requires sufficient separation of the electrodes so that electrolysis products at one electrode cannot reach the other electrode and interfere with the processes at the other electrode during the period of measurement.

In our co-pending application we described a novel method for determining the concentration of the reduced (or oxidised) form of a redox species in an electrochemical cell of the kind comprising a working electrode and a counter (or counter/reference) electrode spaced from the working electrode by a predetermined distance. The method involves applying an electric potential difference between the electrodes and selecting the potential of the working electrode such that the rate of electro-oxidation of the reduced form of the species (or of electro-reduction of the oxidised form) is diffusion con-

trolled. The spacing between the working electrode and the counter electrode is selected so that reaction products from the counter electrode arrive at the working electrode. By determining the current as a function of time after application of the potential and prior to achievement of a steady state current and then estimating the magnitude of the steady state current, the method previously described allows the diffusion coefficient and/or the concentration of the reduced (or oxidised) form of the species to be estimated.

Our co-pending application exemplifies this method with reference to use of a "thin layer electrochemical cell" employing a GOD/Ferrocyanide system. As herein used, the term "thin layer electrochemical cell" refers to a cell having closely spaced electrodes such that reaction product from the counter electrode arrives at the working electrode. In practice, the separation of electrodes in such a cell for measuring glucose in blood will be less than 500 microns, and preferably less than 200 microns.

The chemistry used in the exemplified electrochemical cell is as follows:

reaction 3

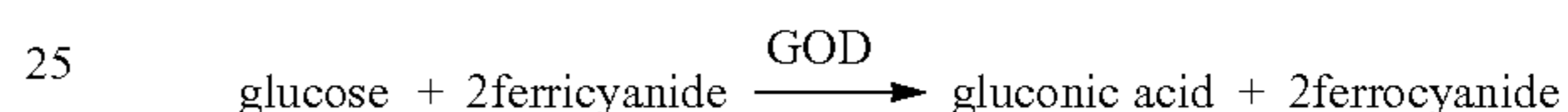

where GOD is the enzyme glucose oxidase, and GOD* is the 'activated' enzyme. Ferricyanide ($[\text{Fe}(\text{CN})_6]^{3-}$) is the 'mediator' which returns the GOD* to its catalytic state. GOD, an enzyme catalyst, is not consumed during the reaction so long as excess mediator is present. Ferrocyanide ($[\text{Fe}(\text{CN})_6]^{4-}$) is the product of the total reaction. Ideally there is initially no ferrocyanide, although in practice there is often a small quantity. After reaction is complete the concentration of ferrocyanide (measured electrochemically) indicates the initial concentration of glucose. The total reaction is the sum of reactions 1 and 2:

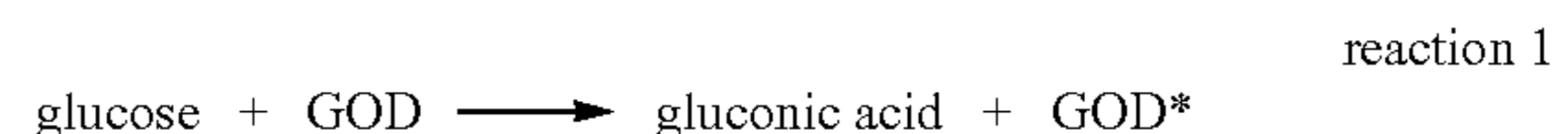

reaction 1

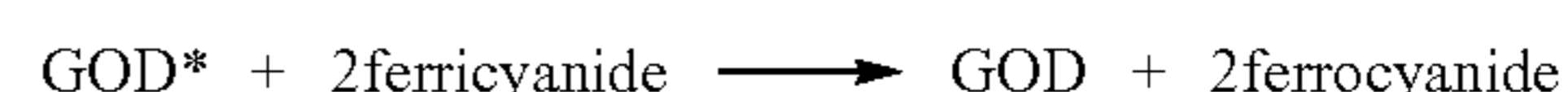

reaction 2

"Glucose" refers specifically to β -D-glucose.

The prior art suffers from a number of disadvantages. Firstly, sample size required is greater than desirable. It would be generally preferable to be able to make measurements on samples of reduced volume since this in turn enables use of less invasive methods to obtain samples.

Secondly, it would be generally desirable to improve the accuracy of measurement and to eliminate or reduce variations due, for example, to cell asymmetry or other factors introduced during mass production of microcells. Likewise, it would be desirable to reduce electrode "edge" effects.

Thirdly, since the cells are disposable after use, it is desirable that they be capable of mass production at relatively low cost.

SUMMARY OF THE INVENTION

In a first embodiment of the present invention, a biosensor for use in determining a concentration of a component in an aqueous liquid sample is provided, the biosensor including: (a) an electrochemical cell, the electrochemical cell including

3

a first electrically resistive substrate having a first thin layer of a first electrically conductive material on a first face, a second electrically resistive substrate having a second thin layer of a second electrically conductive material on a second face, the substrates being disposed with the first electrically conductive material facing the second electrically conductive material and being separated by a sheet including an aperture, the wall of which aperture cooperates with the electrically conductive materials to define a cell wall, and wherein the aperture defines a working electrode area in the cell, the cell further including a sample introduction aperture whereby the aqueous liquid sample may be introduced into the cell; and (b) a measuring circuit.

In one aspect of the first embodiment, the electrochemical cell further includes a socket region having a first contact area in electrical communication with the first thin layer of the first electrically conductive material and a second contact area in electrical communication with the second thin layer of the second electrically conductive material, whereby the electrochemical cell may be electrically connected with the measuring circuit.

In another aspect of the first embodiment, the measuring circuit includes a tongue plug.

In a further aspect of the first embodiment, at least one of the first electrically conductive material and the second electrically conductive material includes a metal. The metal may further include a sputter coated metal.

In still other aspects of the first embodiment, the aqueous liquid sample includes blood, and the component includes glucose.

In yet another aspect of the first embodiment, the measuring circuit includes an automated instrument for detecting an electrical signal from the electrochemical cell and relating the electrical signal to the concentration of the component in the aqueous liquid sample.

In a further aspect of the first embodiment, the electrochemical cell includes a substantially flat strip having a thickness, the strip having at least two lateral edges, and wherein the sample introduction aperture includes a notch through the entire thickness of the strip in at least one of the lateral edges thereof.

In a second embodiment of the present invention, a biosensor for use in determining a concentration of a component in an aqueous liquid sample is provided, the biosensor including: (a) a thin layer electrochemical cell, the cell including: (i) an electrically resistive sheet including an aperture wherein the aperture defines a working electrode area in the cell; (ii) a first electrode layer covering the aperture on a first side of the sheet; (iii) a second electrode layer covering the aperture on a second side of the sheet; and (iv) a passage for admission into the aperture of the aqueous liquid sample; and (b) a measuring circuit.

In one aspect of the second embodiment, the electrochemical cell further includes a socket region having a first contact area in electrical communication with the first electrode layer and a second contact area in electrical communication with the second electrode layer, whereby the electrochemical cell may be electrically connected with the measuring circuit.

In another aspect of the second embodiment, the measuring circuit includes a tongue plug.

In still other aspects of the second embodiment, the aqueous liquid sample includes blood, and the component includes glucose.

In a further aspect of the second embodiment, the measuring circuit includes an automated instrument for detecting an

4

electrical signal from the electrochemical cell and relating the electrical signal to the concentration of the component in the aqueous liquid sample.

In yet another aspect of the second embodiment, the cell includes a substantially flat strip having a thickness, the strip having at least two lateral edges, and wherein the passage for admission into the aperture includes a notch through the entire thickness of the strip in at least one of the lateral edges thereof.

In a third embodiment of the present invention, an apparatus for determining a concentration of a reduced form or an oxidized form of a redox species in a liquid sample is provided, the apparatus including: (a) a hollow electrochemical cell having a working electrode and a counter or counter/reference electrode wherein the working electrode is spaced from the counter or counter/reference electrode by less than 500 μm ; (b) means for applying an electric potential difference between the electrodes; and (c) means for electrochemically determining the concentration of the reduced form or the oxidized form of the redox species in the liquid sample.

In one aspect of the third embodiment, means for electrochemically determining the concentration of the reduced form or the oxidized form of the redox species includes: (i) means for determining a change in current with time after application of the electric potential difference and prior to achievement of a steady state current; (ii) means for estimating a magnitude of the steady state current; and (iii) means for obtaining from the change in current with time and the magnitude of the steady state current, a value indicative of the concentration of the reduced form or the oxidized form of the redox species.

In another aspect of the third embodiment, the cell further includes a socket region having a first contact area in electrical communication with the working electrode and a second contact area in electrical communication with the counter or counter/reference electrode, whereby the cell may be electrically connected with at least one of the means for applying an electric potential difference between the electrodes and the means for electrochemically-determining the concentration of the reduced form or the oxidized form of the redox species in the liquid sample.

In a further aspect of the third embodiment, at least one of the means for applying an electric potential difference between the electrodes and the means for electrochemically determining the concentration of the reduced form or the oxidized form of the redox species in the liquid sample includes a tongue plug.

In yet another aspect of the third embodiment, at least one of the means for applying an electric potential difference between the electrodes and the means for electrochemically determining the concentration of the reduced form or the oxidized form of the redox species in the liquid sample includes an automated instrument for detecting an electrical signal from the electrochemical cell and relating the electrical signal to the concentration of the reduced form or the oxidized form of the redox species in the liquid sample.

In a further aspect of the third embodiment, the cell includes a substantially flat strip having a thickness, the strip having at least two lateral edges, and wherein a notch extends through a wall of the electrochemical cell and through the entire thickness of the strip in at least one of the lateral edges thereof, whereby the liquid sample may be introduced into the cell.

In still other aspects of the third embodiment, the liquid sample includes blood, and the redox species includes glucose.

5

In a fourth embodiment of the present invention, a method for determining a concentration of a reduced form or an oxidized form of a redox species in a liquid sample is provided, the method including: (a) providing a hollow electrochemical cell having a working electrode and a counter or counter/reference electrode wherein the working electrode is spaced from the counter or counter/reference electrode by less than 500 μm ; (b) applying an electric potential difference between the electrodes; and (c) electrochemically determining the concentration of the reduced form or the oxidized form of the redox species in the liquid sample.

In one aspect of the fourth embodiment, step (c) includes: (i) determining a change in current with time after application of the electric potential difference and prior to achievement of a steady state current; (ii) estimating a magnitude of the steady state current; and (iii) obtaining from the change in current with time and the magnitude of the steady state current, a value indicative of the concentration of the reduced form or the oxidized form of the redox species.

In another aspect of the fourth embodiment, the cell further includes a socket region having a first contact area in electrical communication with the working electrode and a second contact area in electrical communication with the counter or counter/reference electrode.

In a further aspect of the fourth embodiment, step (b) further includes the step of: providing an automated instrument for applying an electric potential difference between the electrodes.

In yet another aspect of the fourth embodiment, step (c) includes the steps of: (i) providing an automated instrument for detecting an electrical signal from the electrochemical cell; and (ii) relating the electrical signal to the concentration of the reduced form or the oxidized form of the redox species in the liquid sample.

In a further aspect of the fourth embodiment, the cell includes a substantially flat strip having a thickness, the strip having at least two lateral edges, and wherein a notch extends through a wall of the electrochemical cell and through the entire thickness of the strip in at least one of the lateral edges thereof, whereby the liquid sample may be introduced into the cell.

In still other aspects of the fourth embodiment, the liquid sample includes blood and the redox species includes glucose.

BRIEF DESCRIPTION OF THE DRAWINGS

The invention will now be particularly described by way of example only with reference to the accompanying schematic drawings wherein:

FIG. 1 shows the product of manufacturing step 2 in plan.

FIG. 2 shows the product of FIG. 1 in side elevation.

FIG. 3 shows the product of FIG. 1 in end elevation.

FIG. 4 shows the product of manufacturing step 3 in plan.

FIG. 5 shows the product of FIG. 4 in cross-section on line 5-5 of FIG. 4.

FIG. 6 shows the product of manufacturing step 5 in plan.

FIG. 7 shows the product of FIG. 6 in side elevation.

FIG. 8 shows the product of FIG. 6 in end elevation.

FIG. 9 shows the product of manufacturing step 7 in plan.

FIG. 10 is a cross-section of FIG. 9 on line 10-10.

FIG. 11 shows the product of FIG. 9 in end elevation.

FIG. 12 shows a cell according to the invention in plan.

FIG. 13 shows the call of FIG. 12 in side elevation.

FIG. 14 shows the cell of FIG. 12 in end elevation.

6

FIG. 15 shows a scrap portion of a second embodiment of the invention in enlarged section.

DETAILED DESCRIPTION OF THE PREFERRED EMBODIMENT

The construction of a thin layer electrochemical cell will now be described by way of example of the improved method of manufacture.

Step 1: A sheet 1 of Melinex® (a chemically inert, and electrically resistive Polyethylene Terephthalate ["PET"]) approximately 13 cm \times 30 cm and 100 micron thick was laid flat on a sheet of release paper 2 and coated using a Number 2 MYAR bar to a thickness of 12 microns wet (approximately 2-5 microns dry) with a water-based heat activated adhesive 3 (ICI Novacoat system using catalyst:adhesive). The water was then evaporated by means of a hot air dryer leaving a contact adhesive surface. The sheet was then turned over on a release paper and the reverse side was similarly coated with the same adhesive 4, dried, and a protective release paper 5 applied to the exposed adhesive surface. The edges were trimmed to obtain a sheet uniformly coated on both sides with tacky contact adhesive protected by release paper.

Step 2: The sheet with protective release papers was cut into strips 7, each about 18 mm \times 210 mm (FIGS. 1-3).

Step 3: A strip 7 of adhesive-coated PET from step 2 with release paper 2, 5 on respective sides, was placed in a die assembly (not shown) and clamped. The die assembly was adapted to punch the strip with a locating hole 10 at each end and with for example 37 circular holes 11 each of 3.4 mm diameter at 5 mm centres equi-spaced along a line between locating holes 10. The area of each hole 11 is approximately 9 square mm.

Step 4: A sheet 12 of Mylar® PET approximately 21 cm square and 135 microns thick was placed in a sputter coating chamber for palladium coating 13. The sputter coating took place under a vacuum of between 4 and 6 millibars and in an atmosphere of argon gas. Palladium was coated on the PET to a thickness of 100-1000 angstroms. There is thus formed a sheet 14 having a palladium sputter coating 13.

Step 5: The palladium coated PET sheet 14 from Step 4 was then cut into strips 14 and 15 and a die was used to punch two location holes 16 in each strip, at one end (FIGS. 6, 7 and 8). Strips 14 and 15 differ only in dimension strips 14 being 25 mm \times 210 mm and strips 15 being 23 mm \times 210 mm.

Step 6: A spacer strip 7 prepared as in step 3 was then placed in a jig (not shown) having two locating pins (one corresponding to each locating hole 10 of strip 7) and the upper release paper 2 was removed. A strip 14 of palladium coated PET prepared as in step 5 was then laid over the adhesive layer, palladium surface downwards, using the jig pins to align the locating holes 16 with the underlying PET strip 7. This combination was then passed through a laminator comprising a set of pinch rollers, one of which was adapted to heat the side bearing a palladium coated PET strip 14. The roller on the opposite side of the strip 7 was cooled. By this means, only the adhesive between the palladium of strip 14 and PET strip 7 was activated.

Step 7: PET strip 7 was then turned over and located in the jig with the release coating uppermost. The release coating was peeled off and second palladium coated strip 15 was placed palladium side down on the exposed adhesive surface using the locating pins to align the strips. This assembly was now passed again through the laminator of step 6, this time with the hot roll adjacent the palladium coated Mylar® added in step 7 so as to activate the intervening adhesive (FIGS. 9, 10 and 11).

Step 8: The assembly from step 7 was returned to the die assembly and notches 17 punched in locations so as to extend between the circular holes 11 previously punched in the Melinex® PET and the strip edge 17. Notches 16 extend so as to intercept the circumference of each circular cell. The strip was then guillotined to give 37 individual "sensor strips", each strip being about 5 mm wide and each having one thin layer cavity cell (FIGS. 12, 13 and 14).

There is thus produced a cell as shown in FIG. 12, 13 or 14. The cell comprises a first electrode consisting of PET layer 12, a palladium layer 13, an adhesive layer 3, a PET sheet 1, a second adhesive layer 4, a second electrode comprising palladium layer 13, and a PET layer 12. Sheet 1 defines a cylindrical cell 11 having a thickness in the cell axial direction corresponding to the thickness of the Melinex® PET sheet layer 1 together with the thickness of adhesive layers 3 and 4. The cell has circular palladium end walls. Access to the cell is provided at the side edge of the cell where notches 16 intersect cell 11.

In preferred embodiments of the invention, a sample to be analysed is introduced to the cell by capillary action. The sample is placed on contact with notch 16 and is spontaneously drawn by capillary action into the cell, displaced air from the cell venting from the opposite notch 16. A surfactant may be included in the capillary space to assist in drawing in the sample.

The sensors are provided with connection means for example edge connectors whereby the sensors may be placed into a measuring circuit. In a preferred embodiment this is achieved by making spacer 1 shorter than palladium supporting sheets 14, 15 and by making one sheet 15 of shorter length than the other 14. This forms a socket region 20 having contact areas 21, 22 electrically connected with the working and counter electrodes respectively. A simple tongue plug having corresponding engaging conduct surfaces can then be used for electrical connection. Connectors of other form may be devised.

Chemicals for use in the cell may be supported on the cell electrodes or walls, may be supported on an independent support contained within the cell or may be self-supporting.

In one embodiment, chemicals for use in the cell are printed onto the palladium surface of the electrode immediately after step 1 at which stage the freshly-deposited palladium is more hydrophilic. For example, a solution containing 0.2 molar potassium ferricyanide and 1% by weight of glucose oxidase dehydrogenase may be printed on to the palladium surface. Desirably, the chemicals are printed only in the areas which will form a wall of the cell and for preference the chemicals are printed on the surface by means of an ink jet printer. In this manner, the deposition of chemicals may be precisely controlled. If desired, chemicals which are desirably separated until required for use may be printed respectively on the first and second electrodes. For example, a GOD/ferricyanide composition can be printed on one electrode and a buffer on the other. Although it is highly preferred to apply the chemicals to the electrodes prior to assembly into a cell, chemicals may also be introduced into the cell as a solution after step 6 or step 8 by pipette in the traditional manner and the solvent subsequently is removed by evaporation or drying. Chemicals need not be printed on the cell wall or the electrodes and may instead be impregnated into a gauze, membrane, non-woven fabric or the like contained within, or filling, the cavity (eg inserted in cell 11 prior to steps 6 or 7). In another embodiment the chemicals are formed into a porous mass which may be introduced into the cell as a pellet or granules. Alternatively, the chemicals may be introduced as a gel.

In a second embodiment of the invention a laminate 21 is first made from a strip 14 as obtained in step 5 adhesively sandwiched between two strips 7 as obtained from step 3. Laminate 20 is substituted for sheet 1 in step 5 and assembled with electrodes as in steps 6 and 7.

There is thus obtained a cell as shown in FIG. 15 which differs from that of FIGS. 9 to 11 in that the cell has an annular electrode disposed between the first and second electrode. This electrode can for example be used as a reference electrode.

It will be understood that in mass production of the cell, the parts may be assembled as a laminate on a continuous line. For example, a continuous sheet 1 of PET could be first punched and then adhesive could be applied continuously by printing on the remaining sheet. Electrodes (pre-printed with chemical solution and dried) could be fed directly as a laminate onto the adhesive coated side. Adhesive could then be applied to the other side of the punched core sheet and then the electrode could be fed as a laminate onto the second side.

The adhesive could be applied as a hot melt interleaving film. Alternatively, the core sheet could first be adhesive coated and then punched.

By drying chemicals on each electrode prior to the gluing step the electrode surface is protected from contamination.

Although the cell has been described with reference to Mylar® and Melinex® PET, other chemically inert and electrically resistive materials may be utilised and other dimensions chosen. The materials used for spacer sheet 1 and-for supporting the reference and counter electrodes may be the same or may differ one from the other. Although the invention has been described with reference to palladium electrodes, other metals such as platinum, silver, gold, copper or the like may be used and silver may be reacted with a chloride to form a silver/silver chloride electrode or with other halides. The electrodes need not be of the same metal.

Although the use of heat activated adhesives has been described, the parts may be assembled by use of hot melt adhesives, fusible laminates and other methods.

The dimensions of the sensor may readily be varied according to requirements.

While it is greatly preferred that the electrodes cover the cell end openings, in other embodiments (not illustrated) the electrodes do not entirely cover the cell end openings. In that case it is desirable that the electrodes be in substantial overlying registration.

Preferred forms of the invention in which the electrodes cover the apertures of cell 11 have the advantages that the electrode area is precisely defined simply by punching hole 11. Furthermore the electrodes so provided are parallel, overlying, of substantially the same area, and are substantially or entirely devoid of "edge" effects.

Although in the embodiments described each sensor has one cell cavity, sensors may be provided with two or more cavities. For example, a second cavity may be provided with a predetermined quantity of the analyte and may function as a reference cell.

As will be apparent to those skilled in the art from the teaching herein contained, a feature of one embodiment herein described may be combined with features of other embodiments herein described or with other embodiments described in our co-pending application. Although the sensor has been described with reference to palladium electrodes and a GOD/ferricyanide chemistry, it will be apparent to those skilled in the art that other chemistries, and other materials of construction may be employed without departing from the principles herein taught.

What is claimed is:

1. [A biosensor] *An apparatus* for use in determining a concentration of a component in an aqueous liquid sample, the [biosensor] *apparatus* comprising:

- (a) an electrochemical cell, the electrochemical cell comprising a first electrically resistive substrate having a first thin layer of a first electrically conductive material on a first face, a second electrically resistive substrate having a second thin layer of a second electrically conductive material on a second face, the substrates being disposed with the first electrically conductive material facing the second electrically conductive material and being separated by a sheet comprising an aperture, the wall of which aperture cooperates with the electrically conductive materials to define a cell wall, and wherein the aperture defines a working electrode area in the cell, the cell further comprising a sample introduction aperture whereby the aqueous liquid sample may be introduced into the cell,
- (b) a socket region having a first contact area in electrical communication with the first thin layer of the first electrically conductive material on the first electrically resistive substrate and a second contact area in electrical communication with the second thin layer of the second electrically conductive material on the second electrically resistive substrate, wherein the socket region extends the full width of *at least one of* the first and second electrically resistive substrates, and the first and second electrically resistive substrates have lengths that are different from one another in the socket region; and
- (c) a measuring circuit, the measuring circuit being electrically connectable with the electrochemical cell by engaging with the socket region.

2. The [biosensor] *apparatus* of claim 1, wherein the measuring circuit comprises a tongue plug having conductive surfaces that correspond to a shape of the first and second electrically resistive substrates in the socket region such that the tongue plug can be electrically connected to the socket region.

3. The [biosensor] *apparatus* of claim 1, wherein at least one of the first electrically conductive material and the second electrically conductive material comprises a metal.

4. The [biosensor] *apparatus* of claim 3, wherein the metal comprises a sputter coated metal.

5. The [biosensor] *apparatus* of claim 1, wherein the aqueous liquid sample comprises blood.

6. The [biosensor] *apparatus* of claim 1, wherein the component comprises glucose.

7. The [biosensor] *apparatus* of claim 1, wherein the measuring circuit comprises an automated instrument for detect-

ing an electrical signal from the electrochemical cell and relating the electrical signal to the concentration of the component in the aqueous liquid sample.

8. [A biosensor] *An apparatus* for use in determining a concentration of a component in an aqueous liquid sample, the [biosensor] *apparatus* comprising:

- (a) a thin layer electrochemical cell, the cell comprising:
- (i) an electrically resistive sheet comprising an aperture wherein the aperture defines a working electrode area in the cell;
- (ii) a first electrode layer covering the aperture on a first side of the sheet;
- (iii) a second electrode layer covering the aperture on a second side of the sheet;
- (iv) a passage for admission into the aperture of the aqueous liquid sample; and
- (v) a socket region [for receiving a tongue plug], the socket region having a first contact area in electrical communication with the first electrode layer and a second contact area in electrical communication with the second electrode layer, wherein the socket region extends the full width of *at least one of* the first and second electrode layers and the first and second electrode layers have lengths that are different from one another in the socket region; and
- (b) a measuring circuit.

9. The [biosensor] *apparatus* of claim 8, wherein the electrochemical cell is adapted to electrically connect with the measuring circuit.

10. The [biosensor] *apparatus* of claim 8, wherein the measuring circuit comprises a tongue plug having conductive surfaces that correspond to a shape of the first and second electrode layers in the socket region such that the tongue plug can be electrically connected to the socket region.

11. The [biosensor] *apparatus* of claim 8, wherein the aqueous liquid sample comprises blood.

12. The [biosensor] *apparatus* of claim 8, wherein the component comprises glucose.

13. The [biosensor] *apparatus* of claim 8, wherein the measuring circuit comprises an automated instrument for detecting an electrical signal from the electrochemical cell and relating the electrical signal to the concentration of the component in the aqueous liquid sample.

14. The [biosensor] *apparatus* of claim 8, wherein the cell comprises a substantially flat strip having a thickness, the strip having at least two lateral edges, and wherein the passage for admission into the aperture comprises a notch through the entire thickness of the strip in at least one of the lateral edges thereof.

* * * * *