

US00RE42525E

(19) **United States**  
(12) **Reissued Patent**  
**Simonson**

(10) **Patent Number:** **US RE42,525 E**  
(45) **Date of Reissued Patent:** **Jul. 5, 2011**

(54) **CANNULA AND SIZING INSERTION METHOD**

4,481,947 A 11/1984 Chester  
4,545,374 A 10/1985 Jacobson  
4,573,448 A 3/1986 Kambin  
4,617,922 A 10/1986 Griggs

(75) Inventor: **Robert E. Simonson**, Boca Raton, FL (US)

(Continued)

(73) Assignee: **DePuy Spine, Inc.**, Raynham, MA (US)

**FOREIGN PATENT DOCUMENTS**

(21) Appl. No.: **10/165,991**

WO WO 00/18306 A1 4/2000  
WO WO 02/060330 A1 8/2002

(22) Filed: **Jun. 10, 2002**

**OTHER PUBLICATIONS**

**Related U.S. Patent Documents**

Reissue of:

(64) Patent No.: **6,159,179**  
Issued: **Dec. 12, 2000**  
Appl. No.: **09/266,984**  
Filed: **Mar. 12, 1999**

U.S. Appl. No. 10/899,707, filed Jul. 26, 2004, Robert E. Simonson.

Wolfhard Caspar, *Technique of Microsurgery*, in *Microsurgery of the Lumbar Spine: Principles and Techniques in Spine Surgery 105-122* (Aspen Publications, 1990).

Web page, <http://brainlab.com>, Apr. 2, 2002.

(Continued)

(51) **Int. Cl.**  
**A61M 5/00** (2006.01)

*Primary Examiner*—Theodore J Stigell

(52) **U.S. Cl.** ..... **604/117; 604/164.01; 604/500; 606/108**

(74) *Attorney, Agent, or Firm*—Nutter McClennen & Fish LLP

(58) **Field of Classification Search** ..... **604/117, 604/158, 164.01, 164.1, 164.04, 164.06, 604/164.09-164.11, 264, 272, 500, 506, 604/510, 104; 606/108, 191, 198, 184, 185, 606/61**

(57) **ABSTRACT**

See application file for complete search history.

A relatively inexpensive cannula is sized by including indicia on a cannulated dilator that is used to measure the depth of a body cavity, and in one embodiment with the use of a cuttable fixture inserted into an initially enlarged dilator retractor made from a cuttable material the excess of the dilator retractor is snipped by a commercial cutter. A tool engaging the end of the cannulated dilator provides leverage on the cannulated dilator for rotation as it is forced into the body cavity, a pusher tool provides leverage on the dilator retractor for inserting the dilator retractor into the body cavity. A clamp that fits the top of the dilator retractor serves to support the dilator retractor through an arm to a rigid structure. In an alternate embodiment one of a series of sized dilator retractors are selected commensurate with the measurement attained by the scaled cannulated dilator.

(56) **References Cited**

**U.S. PATENT DOCUMENTS**

569,839 A 10/1896 Roeloffs  
1,633,703 A 6/1927 Kaji  
2,922,420 A \* 1/1960 Cheng ..... 604/272  
3,470,872 A 10/1969 Grieshaber  
3,875,595 A 4/1975 Froning  
4,232,660 A 11/1980 Coles  
4,440,168 A 4/1984 Warren  
4,449,532 A 5/1984 Storz

**27 Claims, 4 Drawing Sheets**

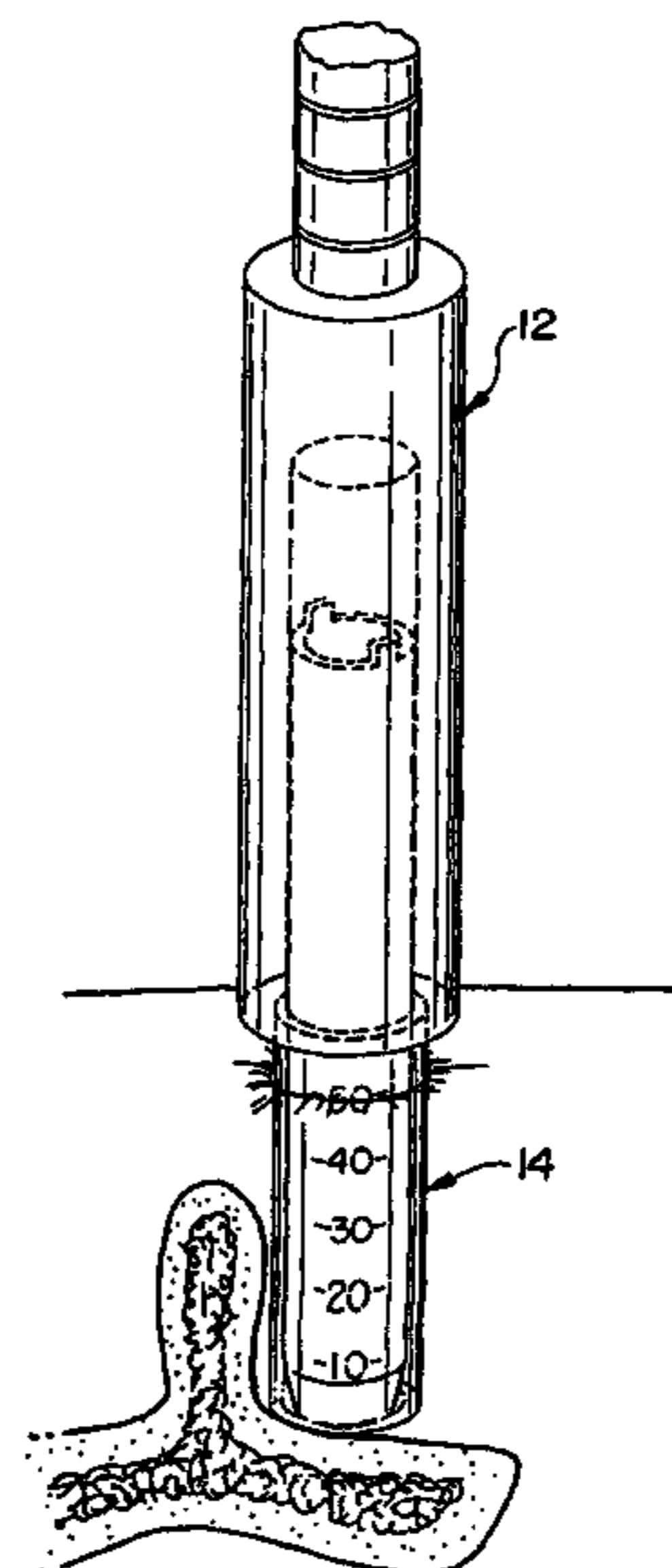

# US RE42,525 E

Page 2

U.S. PATENT DOCUMENTS							
			5,954,635	A *	9/1999	Foley et al. ....	600/114
			5,954,671	A	9/1999	O'Neill	
4,620,460	A	11/1986	5,967,970	A *	10/1999	Cowan et al. ....	600/207
4,686,972	A	8/1987	5,971,920	A	10/1999	Nagel	
4,736,738	A	4/1988	5,976,146	A	11/1999	Ogawa	
4,747,394	A	5/1988	5,996,447	A	12/1999	Bayouth	
4,798,111	A	1/1989	6,007,487	A	12/1999	Foley	
4,803,976	A	2/1989	6,010,520	A	1/2000	Pattison	
4,808,157	A *	2/1989	6,033,406	A	3/2000	Mathews	
4,817,587	A	4/1989	6,063,088	A	5/2000	Winslow	
4,862,891	A *	9/1989	6,080,155	A	6/2000	Michelson	
4,863,423	A *	9/1989	6,081,741	A	6/2000	Hollis	
4,872,451	A	10/1989	6,083,225	A	7/2000	Winslow	
4,882,958	A	11/1989	6,113,602	A	9/2000	Sand	
4,952,214	A	8/1990	6,120,434	A	9/2000	Kimura	
4,969,888	A	11/1990	6,120,506	A	9/2000	Kohrs	
5,035,232	A	7/1991	D433,296	S	11/2000	Yamakawa	
5,048,379	A	9/1991	6,152,871	A	11/2000	Foley	
5,052,373	A	10/1991	6,156,006	A *	12/2000	Brosens et al. ....	604/104
5,084,043	A	1/1992	6,159,179	A	12/2000	Simonson	
5,098,435	A	3/1992	6,162,170	A	12/2000	Foley	
5,106,376	A *	4/1992	6,162,236	A	12/2000	Osada	
5,133,720	A	7/1992	D436,513	S	1/2001	Yamakawa	
5,135,525	A	8/1992	6,176,823	B1	1/2001	Foley	
5,148,724	A	9/1992	D438,074	S	2/2001	Marr	
5,158,543	A *	10/1992	6,197,002	B1	3/2001	Peterson	
5,171,279	A	12/1992	6,206,822	B1	3/2001	Foley	
5,195,541	A	3/1993	6,206,826	B1	3/2001	Mathews	
5,242,443	A	9/1993	6,206,885	B1	3/2001	Ghahremani	
5,275,611	A	1/1994	6,214,004	B1	4/2001	Coker	
5,279,567	A *	1/1994	6,217,509	B1	4/2001	Foley	
5,292,309	A *	3/1994	6,224,597	B1	5/2001	Coker	
5,303,694	A	4/1994	6,224,608	B1 *	5/2001	Ciccolella et al. ....	606/108
5,312,360	A	5/1994	6,245,072	B1	6/2001	Zdeblick	
5,342,384	A	8/1994	6,258,097	B1	7/2001	Cook	
5,356,413	A	10/1994	6,267,763	B1	7/2001	Castro	
5,363,841	A	11/1994	6,270,498	B1	8/2001	Michaelson	
5,403,264	A *	4/1995	6,273,896	B1	8/2001	Franck et al.	
5,431,639	A *	7/1995	6,283,966	B1	9/2001	Houfburg	
5,431,651	A	7/1995	6,287,313	B1	9/2001	Sasso	
D361,381	S	8/1995	6,296,609	B1	10/2001	Brau	
5,439,464	A	8/1995	6,312,432	B1	11/2001	Leppelmeier	
5,472,426	A *	12/1995	6,342,057	B1	1/2002	Brace	
5,489,274	A *	2/1996	6,348,058	B1	2/2002	Melkent	
5,512,038	A	4/1996	6,354,176	B1	3/2002	Nordlin	
5,562,677	A	10/1996	6,371,959	B1	4/2002	Trice	
5,569,248	A	10/1996	6,371,968	B1	4/2002	Kogasaka	
5,601,550	A	2/1997	6,395,007	B1	5/2002	Bhatnagar et al.	
5,611,778	A *	3/1997	6,418,821	B1	7/2002	Yamakawa	
5,687,739	A *	11/1997	6,428,472	B1	8/2002	Haas	
5,716,415	A	2/1998	6,461,330	B1	10/2002	Miyagi	
5,728,097	A	3/1998	D466,766	S	12/2002	Marty	
5,743,853	A	4/1998	6,520,907	B1	2/2003	Foley	
5,746,720	A	5/1998	6,524,238	B2	2/2003	Velikaris et al.	
5,746,720	A	5/1998	6,530,926	B1	3/2003	Davison	
5,766,221	A	6/1998	6,530,929	B1	3/2003	Justis et al.	
5,792,044	A *	8/1998	6,540,756	B1	4/2003	Vaughan	
D399,955	S	10/1998	6,558,386	B1	5/2003	Cragg	
5,816,257	A	10/1998	6,607,530	B1	8/2003	Carl dt al.	
RE36,020	E	12/1998	6,692,434	B2	2/2004	Ritland	
5,851,207	A	12/1998	6,793,656	B1	9/2004	Mathews	
5,882,344	A	3/1999	6,921,403	B2	7/2005	Cragg et al.	
5,885,299	A	3/1999	6,929,606	B2	8/2005	Titland	
5,885,300	A	3/1999	7,008,424	B2	3/2006	Teitelbaum	
5,891,147	A	4/1999	7,008,431	B2	3/2006	Simonson	
5,895,352	A	4/1999	7,435,219	B2	10/2008	Kim	
5,895,390	A	4/1999	7,476,240	B2	1/2009	Raymond et al.	
5,897,593	A	4/1999	7,648,506	B2	1/2010	McCord et al.	
5,899,901	A	5/1999	7,648,507	B2	1/2010	Techiera et al.	
5,902,231	A	5/1999	2001/0012942	A1	8/2001	Estes	
5,913,818	A	6/1999	2001/0027320	A1	10/2001	Sasso	
5,928,139	A	7/1999					
5,944,658	A	8/1999					

2002/0011135	A1	1/2002	Hall
2002/0016592	A1	2/2002	Branch
2002/0022764	A1	2/2002	Smith
2002/0045904	A1	4/2002	Fuss et al.
2002/0049368	A1	4/2002	Ritland
2002/0058948	A1	5/2002	Arlettaz
2002/0077632	A1	6/2002	Tsou
2002/0082695	A1	6/2002	Neumann
2002/0088695	A1	7/2002	Migimatsu et al.
2002/0123668	A1	9/2002	Ritland
2002/0143235	A1	10/2002	Pagliuca
2003/0083688	A1	5/2003	Simonson
2003/0083689	A1	5/2003	Simonson
2003/0187431	A1	10/2003	Simonson
2003/0220689	A1	11/2003	Ritland
2003/0236447	A1	12/2003	Ritland
2004/0106997	A1	6/2004	Lieberson
2005/0004593	A1	1/2005	Simonson
2005/0080418	A1	4/2005	Simonson et al.
2005/0085813	A1	4/2005	Spitler et al.
2005/0131421	A1	6/2005	Anderson et al.
2005/0136085	A1	6/2005	Bellamy
2005/0137461	A1	6/2005	Marchek et al.
2005/0203490	A1	9/2005	Simonson
2005/0216002	A1	9/2005	Simonson
2007/0134175	A1	6/2007	Bellamy
2010/0222824	A1	9/2010	Simonson

OTHER PUBLICATIONS

Kambin, Parviz, "Arthroscopic Microdiscectomy: Minimal Intervention in Spinal Surgery", National Library of Medicine, 1991, p. 67-100, Urban & Schwarzenberg.

Schaffer, Johnathan et al., "Percutaneous Posterolateral Lumbar Discectomy and decompression with a 6.9 Millimeter Cannula", The Journal of Bone and Joint Surgery, 1991, pp. 822-831.

Savitz, Martin, "Same-Day Microsurgical Arthroscopic Lateral-Approach Laser-Assisted (SMALL) Fluoroscopic Discectomy", Journal of Neurosurgery; Jun. 1994, pp. 1039-1045.

Kambin, Parviz, "Percutaneous Posterolateral Discectomy", Clinical Orthopaedics and Related Research, Section II, pp. 145-154.

Sofamor Danek Video Systems Brochure.

Hilton, Donald et al., "Medtronic Sofamor Danek METRX Microdiscectomy Surgical Technique Brochure", 2001.

Wiltse, "New Uses and Refinements of the Paraspinal Approach to the Lumbar Spine", Spine, vol. 13 No. 6 1988, p. 696-706.

Sofamor Danek, "MED MicroEndoscopic Discectomy System" (1997).

Schreiber, et al., "Does Percutaneous Nucleotomy with Discoscopy Replace Conventional Discectomy?", Clinical Orthopaedics and Related Research, No. 238, Jan. 1989.

Hsu, Ken et al., "Internal Fixation With Pedicle Screws," Lumbar Spine Surgery, Techniques and Complications, The C. V. Mosby Company pp. 322-338 (1987).

Kambin, Parviz, "Posterolateral Percutaneous Lumbar Interbody Fusion," Arthroscopic Microdiscectomy: Minimal Intervention In Spinal Surgery, pp. 117-121 (1991).

Kambin, Parviz, "Arthroscopic Lumbar Intervertebral Fusion," The Adult Spine: Principles and Practice, ch. 95, pps. 2037-2046 (1997).

Kambin, Parviz, "Arthroscopic Techniques for Spinal Surgery," Operative Arthroscopy, ch. 89, pp. 1215-1225 (1996).

Kambin, Parviz and Schaffer, Jonathan, "Arthroscopic Fusion of the Lumbosacral Spine," Lumbosacral and Spinopelvic Fixation, ch. 44, pp. 565-577 (1996).

Leu, Hans-Jorg and Schreiber, Adam, "Percutaneous Lumbar Restabilization," Arthroscopic Microdiscectomy: Minimal Intervention in Spinal Surgery, pp. 123-125 (1990).

Leu, Hansjoerg Franz, et al., "Lumber Percutaneous Endoscopic Interbody Fusion," Clinical Orthopaedics And Related Research, No. 337, pp. 58-63 (1997).

Leu, Hans-Jorg and Schreiber, Adam, "La Nucleotomie Percutanees Avec Discoscopie: Experiences Depuis 1979 Et Possibilities Actuelles," Revue Medicale De La Suisse Romande, vol. 109, pp. 477-482 (1989).

Schettrumpf, Jr., "Combined Retractor and Sucker with Built-in Clearing Device for Spinal Surgery," Injury, 1973, pp. 352-3, vol. 4(4).

Ozer, "A New Retractor for the Anterior Cervical Approach," Br J Neurosurg, 1994, pp. 469-70, vol. 8(4).

Styf, "The Effects of External Compression by Three Different Retractors on Pressure in the Erector Spine Muscles During and After Posterior Lumbar Spine Surgery in Humans," Spine, 1998, pp. 354-8, vol. 23(3), Lippincott-Raven Publishers.

Frank, "Endoscopic Dural Retractor for Spinal Stenosis Surgery," Minim Invasive Neurosurg, 2002, pp. 136-8, vol. 45(3).

Barone, "An Improved Retractor for the Anterior Approach in the Surgical Management of Vertebral Fractures," Am J Orthop, 1998, pp. 703-04, vol. 27(10).

Board of Patent Appeals and Interferences Decision in U.S. Appl. No. 10/899,707 dated Dec. 2, 2010.

Reply Brief in U.S. Appl. No. 10/899,707 dated Feb. 7, 2007.

Examiner's Answer in U.S. Appl. No. 10/899,707 dated Dec. 13, 2006

Appeal Brief in U.S. Appl. No. 10/899,707 dated May 31, 2006.

Advisory Action in U.S. Appl. No. 10/899,707 dated Mar. 29, 2006.

Amendment in U.S. Appl. No. 10/899,707 dated Mar. 13, 2006.

Office Action in U.S. Appl. No. 10/899,707 dated Feb. 7, 2006.

Amendment in U.S. Appl. No. 10/899,707 dated Nov. 16, 2005.

Office Action in U.S. Appl. No. 10/899,707 dated Aug. 16, 2005.

Amendment in U.S. Appl. No. 10/899,707 dated Jul. 5, 2005.

Office Action in U.S. Appl. No. 10/899,707 dated Mar. 31, 2005.

Amendment in U.S. Appl. No. 10/899,707 dated Feb. 5, 2005.

Office Action in U.S. Appl. No. 10/899,707 dated Dec. 8, 2004.

Schettrumpf, Jr., "Combined Retractor and Sucker with Built-in Clearing Device for Spinal Surgery," Injury, 1973, pp. 352-3, vol. 4(4).

Ozer, "A New Retractor For The Anterior Cervical Approach," *Br J Neurosurg*, 1994, pp. 469-70, vol. 8(4).

Styf, "The Effects of External Compression by Three Different Retractors on Pressure in the Erector Spine Muscles During and After Posterior Lumbar Spine Surgery in Humans," *Spine*, 1998, pp. 354-8, vol. 23(3), Lippincott-Raven Publishers.

Frank, "Endoscopic Dural Retractor for Spinal Stenosis Surgery," *Minim Invasive Neurosurg*, 2002, pp. 136-8, vol. 45(3).

Barone, "An Improved Retractor for the Anterior Approach in the Surgical Management of Vertebral Fractures," *Am J Orthop*, 1998, pp. 703-04, vol. 27(10).

\* cited by examiner

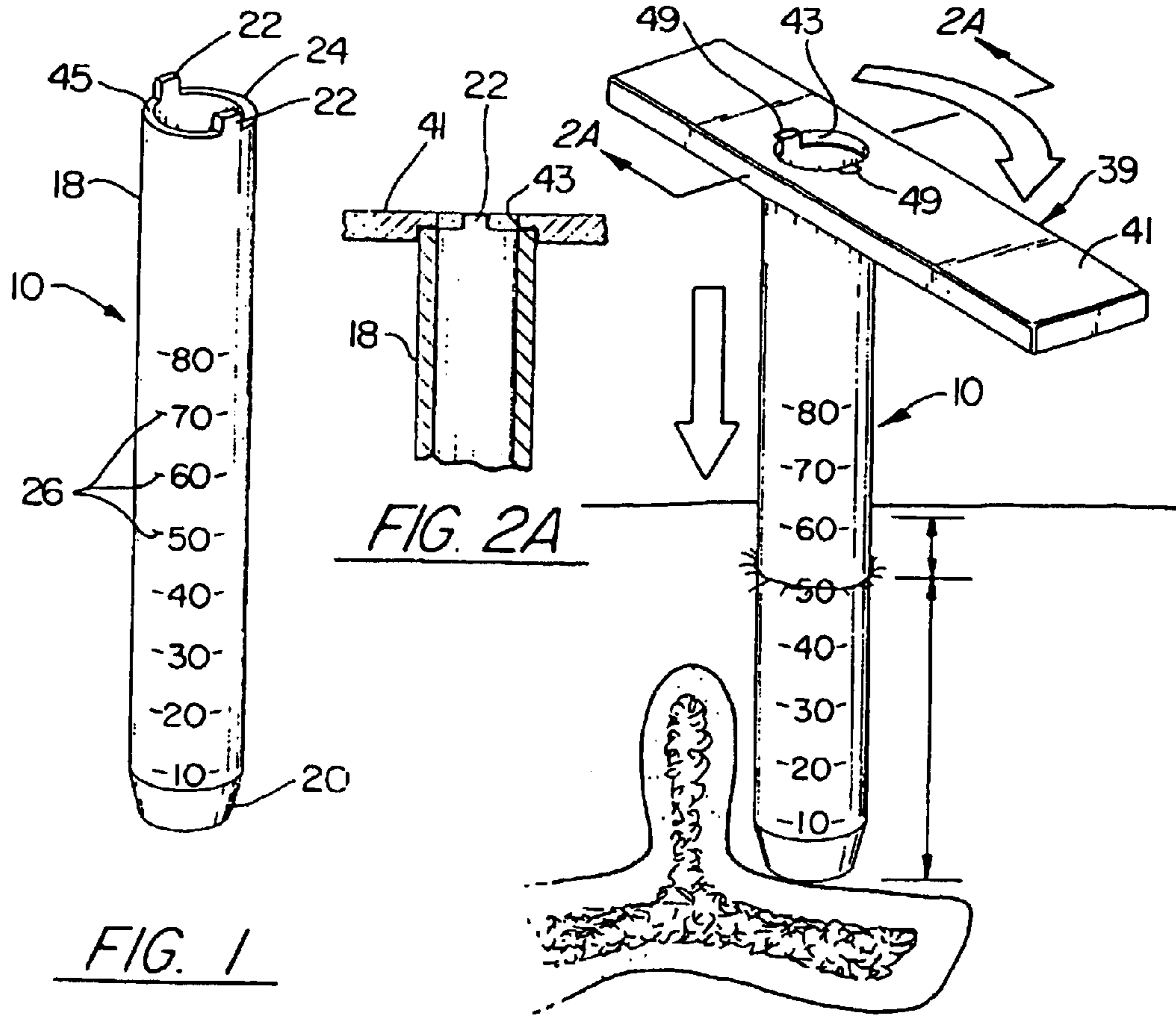

FIG. 1

FIG. 2

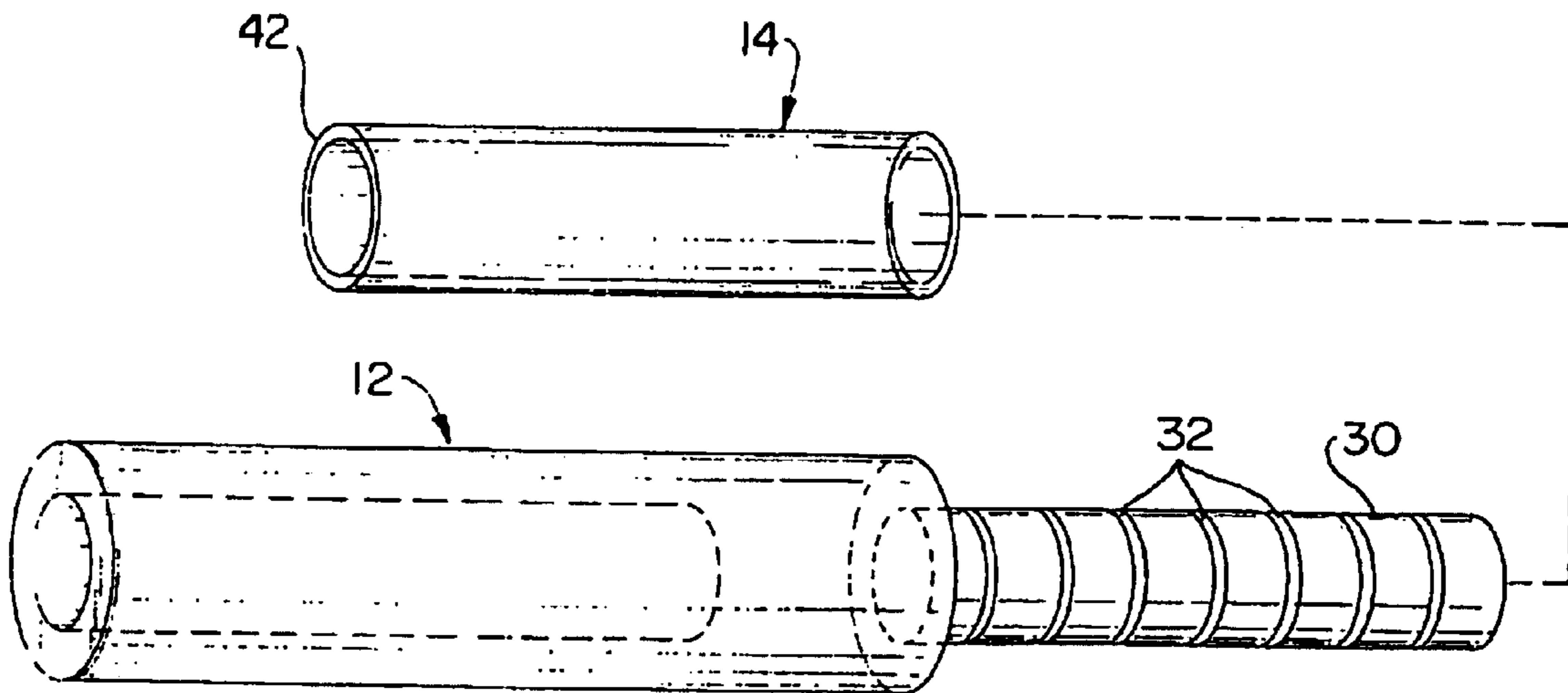

FIG. 3

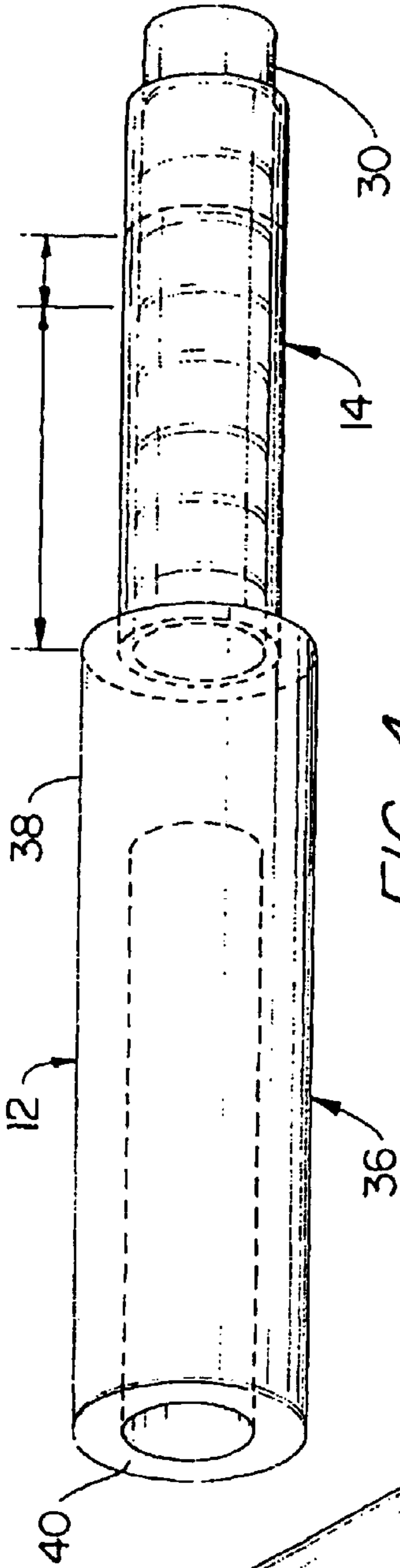

FIG. 4

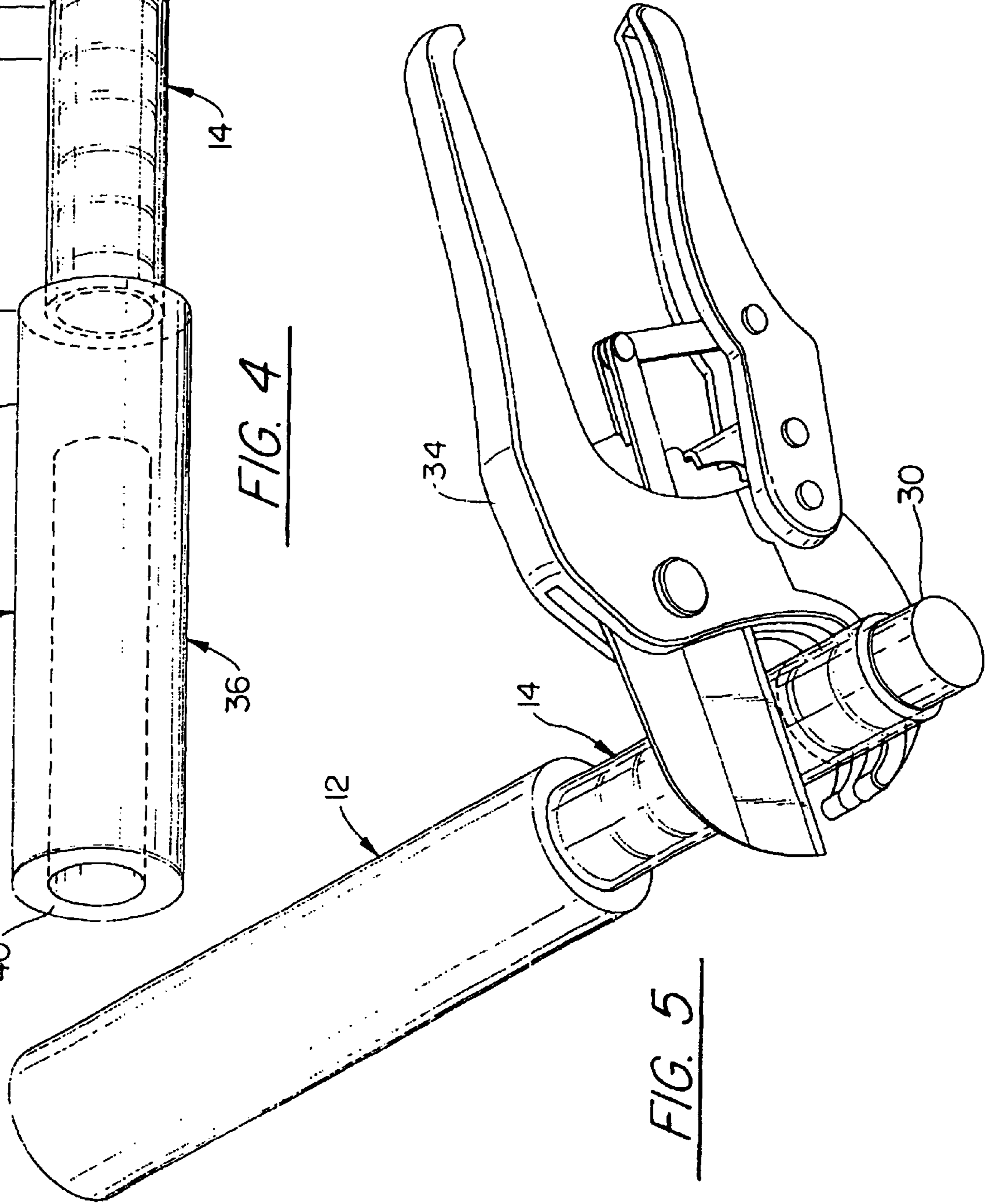
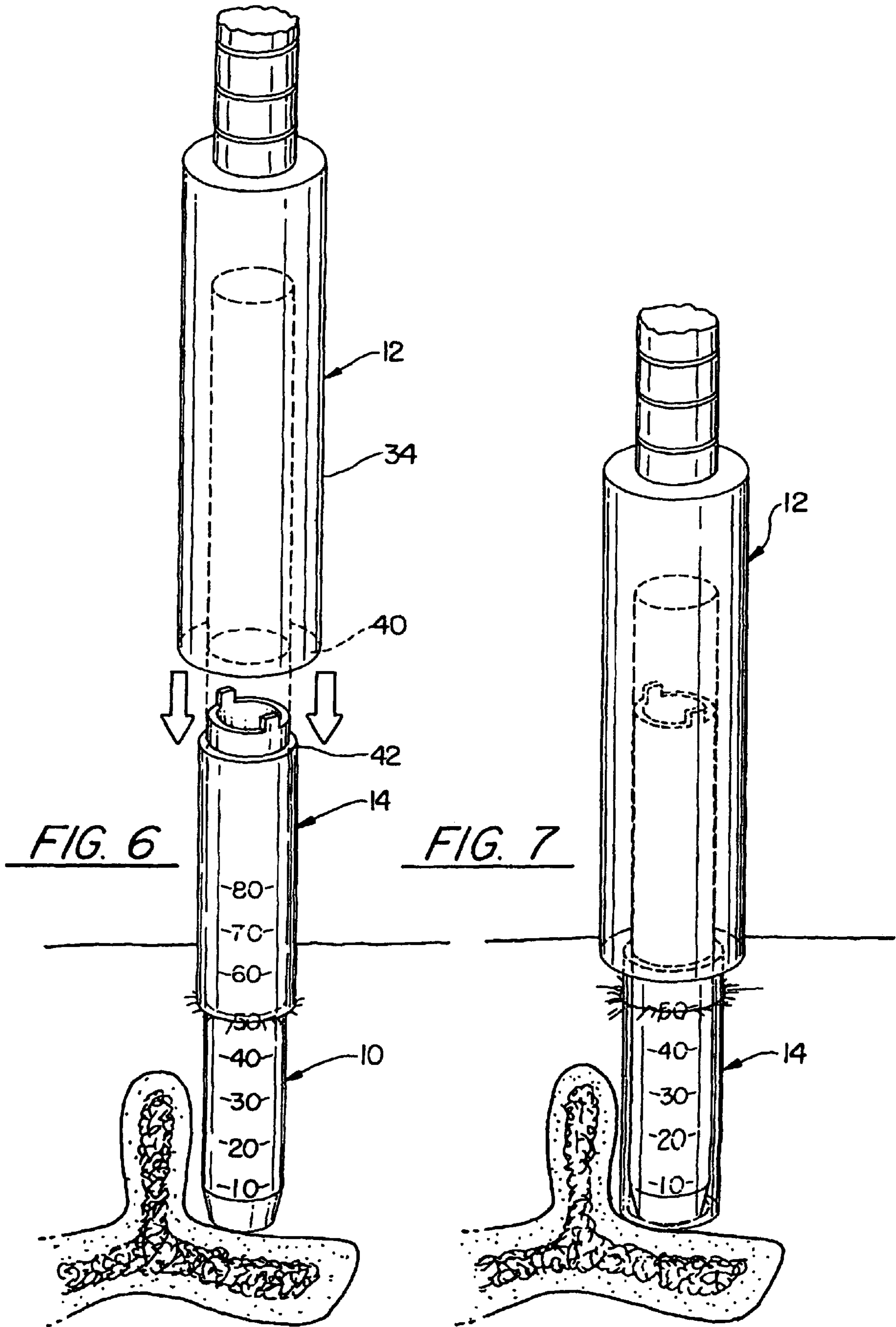
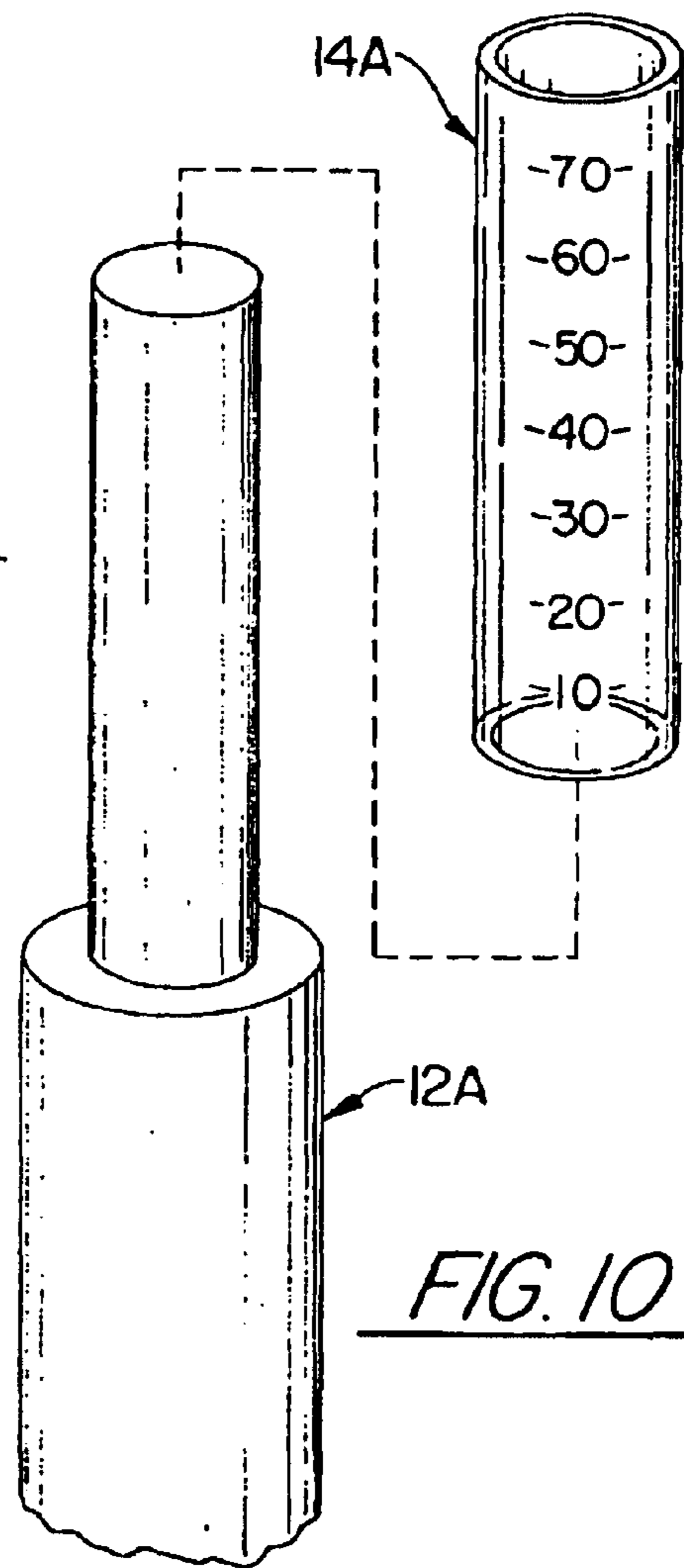
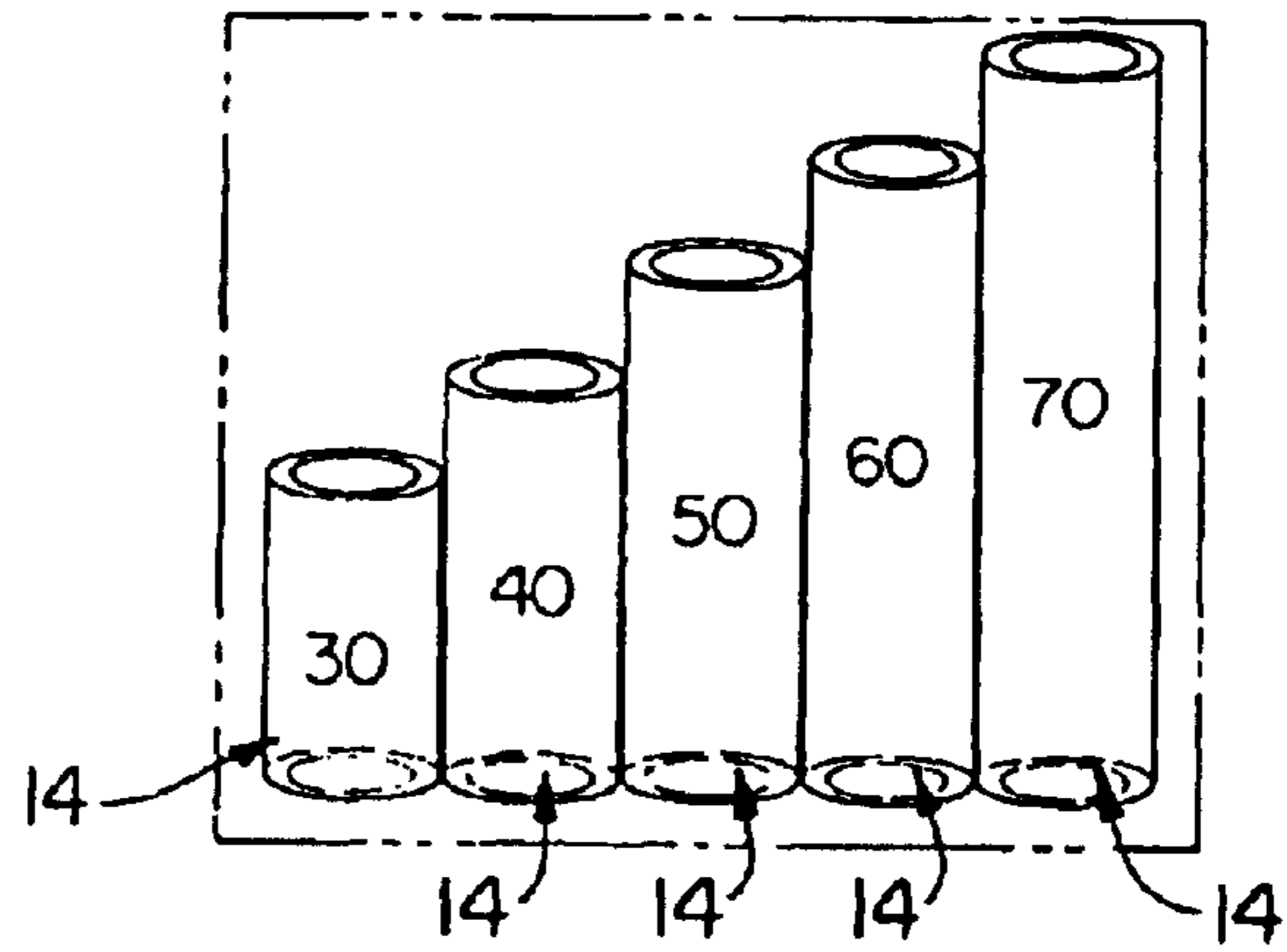
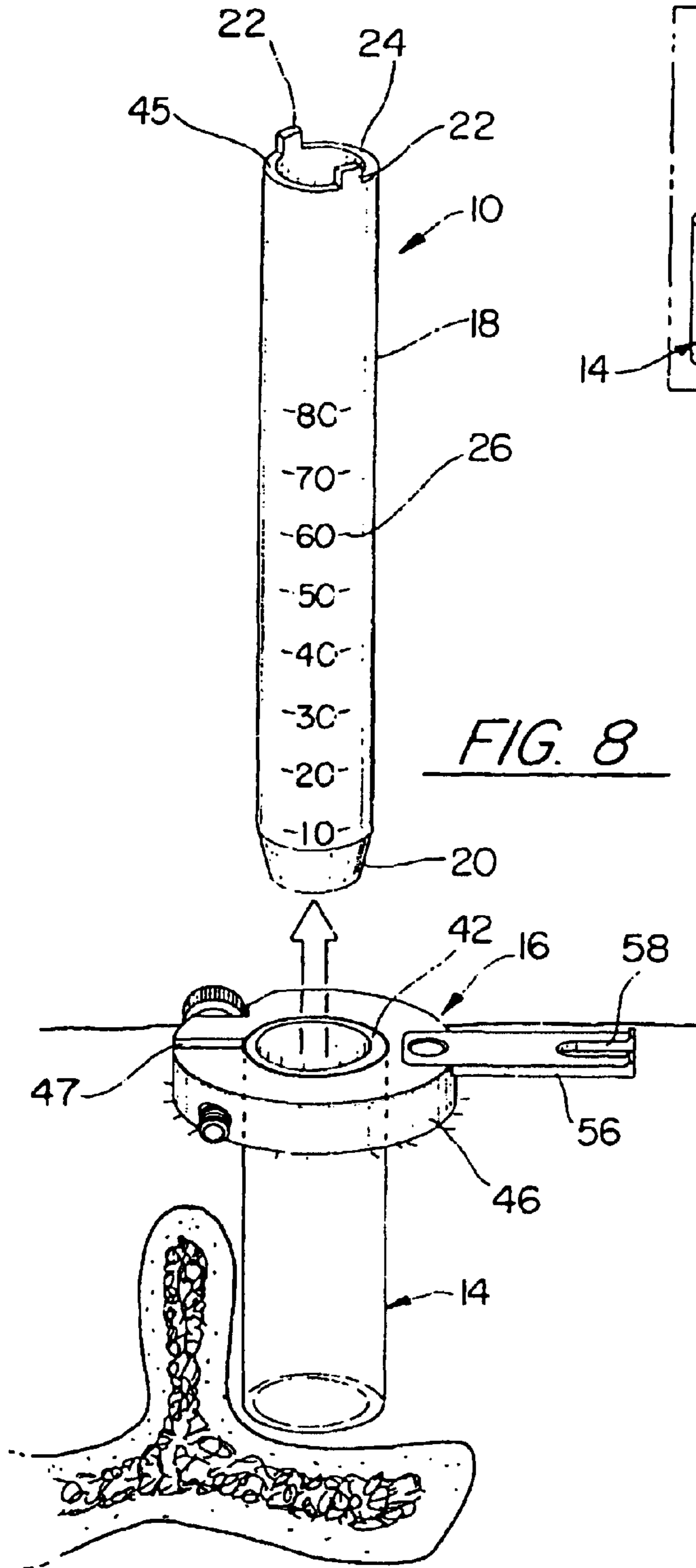

FIG. 5







## CANNULA AND SIZING INSERTION METHOD

**Matter enclosed in heavy brackets [ ] appears in the original patent but forms no part of this reissue specification; matter printed in italics indicates the additions made by reissue.**

### TECHNICAL FIELD

This invention relates to a cannula and cannulated dilator and more particularly to a cannula intended to be utilized in surgery on a patient which cannula is sized by the measurement obtained from the cannulated dilator for obtaining a desired length of the cannula inserted into the body cavity of the patient for ease of the surgical procedure being performed by the surgeon and the apparatus for insertion of the cannulated dilator and the dilator retractor into the body cavity.

### BACKGROUND OF THE INVENTION

As is known in the medical field, the cannula is utilized for creating a passage extending from the exterior into a cavity in the patient to a particular location where the surgical procedure is to be performed. For example, in current day practices lumbar discectomy whose objective is to decompress the affected nerve root, endoscopic and micro endoscopic techniques are often used. These techniques are becoming popular inasmuch as the patient benefits from the small incision, limited tissue disruption, better visualization and illumination all of which shortens the hospital stay and hastens recovery. One of the techniques for performing the lumbar discectomy is the use of tubular retractor (a specific cannula) which allows for laminotomy, deical facetectomy, foraminotomy, nerve root retraction and discectomy. A typical procedure is to advance a guidewire through a small incision which is advanced to the inferior edge of the superior lamina. A small incision is then made that extends either cranially or caudally. A [cannulated] *cannulated* dilator is then inserted over the guidewire. Larger diameter cannulated dilators are sequentially inserted over each other to increase the opening into the body cavity. Typically the guide wire is removed after the first cannulated dilators installed and eventually the cannulated dilators are all removed after the, tubular retractor has been inserted over the largest of the cannulated dilators. Once these procedures are accomplished, the tubular retractor is locked into position by a retractor clamp that is clamped to a retractor clamping arm which is fixed to a rigid member such as the operating table. This provides an unencumbered zone where the surgeon can perform the medical procedure that was intended to be performed.

As is well known in this field of technology, the cannulated dilators and tubular retractors are made from surgical metal material and are sized for the largest depth that is anticipated in the surgical procedure. Hence, whether the depth is 10 millimeters (mm), 20 mm, 30 mm, etc. Measured from the exterior of the cavity to the most interior position in the cavity (inferior edge of the superior lamina) the tubular retractor that may be available for use in the surgical procedure could be 100 mm or larger. The additional or excess length of the dilator retractor is not only cumbersome to use, it is unnecessary and undesirable.

This invention obviates this problem by providing the necessary elements that allow the dilator retractor (cannula) to be cut to size once the incision and diameter of the cavity has been established. Hence, in the surgical procedure

described above the last cannulated dilator in the procedure in accordance with this invention includes indicia of a graduated vertical scale on the tubular wall, preferably in millimeters that is viewed by the user. A cannula or dilator retractor, which basically is a cylindrical tube made from a plastic or synthetic material in one preferred embodiment or surgical metal in another embodiment which is easy to cut and which is transparent in one embodiment and opaque in another is provided in the largest length contemplated in this particular procedure or alternatively is pre-sized in a series of sized cannulas. A template that has a diameter that is slightly smaller than the diameter of the dilator retractor made from a soft plastic material such as Teflon material that may include graduated annular grooves that are graduated vertically in scale that is commensurate with the indicia scale on the cannulated dilator. Or alternatively, the dilator retractor may also include on the wall indicia corresponding to the indicia on the cannulated dilator. Hence, the surgeon or user merely has to count the annular grooves or the indicia on the wall of the dilator retractor to match the depth of the cavity and with a cutter, cut through the dilator retractor which will provide a cannula that is acceptable to the surgeon without the unnecessary length that has heretofore presented a problem.

An annular retractor clamp is provided to fit over the top of the dilator retractor which obviously is sized to accommodate the width of the retractor clamp which, in turn, is utilized to mate with a rigid holder that is clamped to a rigid member such as the operating table or other convenient member to secure the cannula in place.

This invention also contemplates a tool for insertion of the cannulated dilator and a tool for the insertion of the dilator retractor into the body cavity. The tool for insertion of the cannulated dilator is a rectangular shaped planar member that removably fits the cannulated dilator and serves to provide leverage for the surgeon to turn the dilator retractor while it is being inserted into the body cavity to reach its ultimate destination. A tool for insertion of the dilator retractor is generally a pusher which may be made integral with the template includes an inner bore that is slightly larger than the outer diameter of the cannulated dilator and includes a flat bottom surface that overlies the top end wall surface of the dilator retractor so that the pusher provides leverage for the surgeon to slide the dilator retractor over the scaled cannulated dilator until it reaches the final destination in the body cavity.

As an alternate to the use of the cutter and template, it is contemplated within the scope of this invention, that a series of different length dilator retractors will be made available so that the surgeon after making the measurement of the depth of body cavity with the cannulated dilator will select the dilator retractor that most closely matches the size desired.

### SUMMARY OF THE INVENTION

An object of this invention is to provide a dilator retractor that is sized to fit the patient for use in a surgical procedure.

A feature of this invention is to provide indicia of a vertical scale on the cannulated dilator to ascertain the depth of the cavity in the body in which a medical procedure is to be performed. In one embodiment a template made from a relatively soft plastic material fits into the dilator retractor having a scale commensurate with the scale on the cannulated dilator for supporting the dilator retractor as it is cut to the desired length. In another embodiment the dilator retractor includes indicia on the outer surface that correlates to the indicia on the cannulated dilator. In one embodiment the

dilator retractor is transparent, in another embodiment it is opaque, and it can be made from either plastic or metallic material when in the opaque embodiments.

Another feature of this invention is the provision of a tool that is adapted to fit the cannulated dilator to allow the surgeon to turn the cannulated dilator as the surgeon pushes the cannulated dilator into the body cavity against the resistance of the body tissue. In one embodiment the tool includes concentric bores that define a shoulder that engages the end of the cannulated dilator and recesses that engage tabs axially extending from the proximate end of the cannulated dilator.

An alternative to the cutting procedure is the provision of predetermined different length dilator retractors that permit the surgeon to select the desired length commensurate with the depth of the body cavity.

Another feature of this invention is an annular retractor clamp that is slidable over the outer surface of the dilator retractor that is locked into place and adaptable to fit onto a flexible arm that is rigidly connected to a static structure such as the operating table.

The foregoing and other features of the present invention will become more apparent from the following description and accompanying drawings.

#### BRIEF DESCRIPTION OF THE DRAWINGS

FIG. 1 is a perspective view in elevation showing the details of the cannulated dilator of this invention;

FIG. 2 is a perspective view in elevation and section of the cannulated dilator inserted into the cavity of a body and extending to the inferior edge of the superior lamina and a turning tool adapted to retractor clamp onto the tabs extending from the proximate end of the cannulated dilator;

FIG. 2A is a partial view in cross section taken along the lines 2A—2A of FIG. 2;

FIG. 3 is an exploded view in perspective illustrating the dilator retractor being fitted onto the graduated template and pusher prior to being cut to the desired length;

FIG. 4 is a view in perspective illustrating the dilator retractor fitted onto the template;

FIG. 5 is a view in perspective illustrating the dilator retractor being cut by a commercially available cutting tool;

FIG. 6 is a view in perspective illustrating the pusher for pushing the dilator retractor into the body cavity;

FIG. 7 is a view in perspective illustrating the pusher and dilator retractor of FIG. 6 when pushed to the destination;

FIG. 8 is a view in perspective of the dilator retractor and the retractor clamp and the cannulated dilator of this invention;

FIG. 9 is a view in perspective of a series of pre-sized dilator retractors made from an inexpensive material that as an alternative embodiment to the cut in situ dilator retractor; and

FIG. 10 is a perspective exploded view similar to FIG. 3 showing another embodiment with the grooves in the template removed and the dilator retractor having indicia on the outer surface.

#### DETAILED DESCRIPTION OF THE INVENTION

While in the preferred embodiment this invention is being described in connection with a particular surgical procedure, namely, a lumbar disectomy, it is to be understood that this invention has utility in other types of procedures and as one skilled in this art can appreciate, the invention has particular

utility where it is desirable to provide a length of the cannula that is commensurate with the depth of the body cavity. As used in this patent application the term “cannulated dilator” means a surgical instrument that is utilized to widen the body cavity and the term “dilator retractor” is a cannula intended to fit into the body cavity. As used throughout this disclosure the term “body cavity” unless indicated otherwise refers to an access hole formed in the body of the patient in order to reach the target where the medical procedure is being performed and the term cannula or dilator retractor serves to define a working cavity or chamber that the surgeon uses to perform a medical procedure. While in the preferred embodiment, it is preferred that the dilator retractor is made from a plastic material and is transparent as will be appreciated and as will be described herein below this invention contemplates a dilator retractor made from metallic material and in certain embodiments the material is opaque.

To best understand this invention reference is being made to FIGS. 1 through 8 which shows the cannulated dilator generally illustrated by reference numeral 10 (FIGS. 1, 2, 6, 8), the template and pusher tool instrument combination generally illustrated by reference numeral 12 (FIGS. 3–6), the dilator retractor generally illustrated by reference numeral 14 (FIGS. 3, 6, 7, 8) and the retractor clamp generally illustrated by reference numeral 16 (FIG. 8). As best seen in FIG. 1 the cannulated dilator 10 comprises a hollow tubular body 18 typically made from surgical metal such as surgical stainless steel, having a beveled end 20 at the distal end of the tubular body 18 and a pair of circumferentially spaced tabs 22 extending from the proximate end surface 24 of the tubular body 18. The beveled at the distal end 20 serves to help the insertion of the cannulated retractor 10 entering the body of the patient and the tabs 22 serve to fit into a tool that the surgeon utilizes to insert the cannulated dilator 10 as it progresses into the body until it reaches the inferior edge of the superior lamina as will be described in more detail hereinbelow. It is contemplated within the scope of this invention that other techniques for attaching the tool to the cannulated dilator 10 could be utilized, as for example a poly-sided recesses or reversal of the tabs by affixing them to the tool rather than the cannulated dilator and affixing complementary recesses in the cannulated dilator and other such techniques could be employed. What is contemplated by the tool is that it provides leverage to the user so that it allows the cannulated dilator to be turned while it is being pushed into the body cavity against the resistance of the body's tissues.

In accordance with this invention, indicia 26 is placed on the exterior of the body 18 and is a graduated scale in millimeters (although any other unit of measurement can be utilized) that serves to indicate the depth of the body cavity and is used to determine the length of the dilator retractor 14 as will be described in more detail herein below. The dilator retractor 14 in one embodiment is made from a plastic material that is transparent and is sufficiently strong that exhibits hoop integrity that is capable of withstanding the forces of the tissue tending to exert a lateral force. This provides a relatively inexpensive member that is capable of being cut while the patient is in the operating room. In one embodiment the dilator retractor is fitted onto the fixture—and the fixture includes spaced grooves that are correlated to the measurement of the depth of the body cavity that is determined by the indicia of the cannulated dilator 10.

As mentioned above, once the depth of the body cavity as measured by the indicia on the cannulated dilator 10, the dilator retractor 14 is fitted on the scaled end of the template portion 30 which includes a series of annular grooves that

5

are axially spaced a predetermined distance, say at 10 mm, so that the dilator retractor **14** being transparent in this instance, once fitted onto the template can be sized. Hence, the user merely counts the number of grooves that is commensurate with the measurement taken from the indicia of the cannulated dilator and the desired length is then cut to the desired length. Obviously, it is important that the dilator retractor **14** is initially oversized so that the length will be longer than any of the depths of the body cavity contemplated. Hence, in this manner the cannula is made to fit each individual patient. The technique for making the measurement and cutting to size is described as follows. If the depth of the body cavity measurement taken from the cannulated dilator was 30 mm the user would count 3 annular grooves which are spaced 10 mm apart to determine the length of the dilator retractor desired and would add an addition amount to compensate for the attachment dimension of the annular retractor clamp **[18]** **16**. Hence, if the width of the clamp **[18]** **16** is 10 mm and the depth of cavity is 30 mm, the user would select 40 mm as the juncture where the dilator retractor is cut to size.

Once the length of the depth of the body cavity as calculated by the cannulated dilator **10** is determined and while the dilator retractor **14** is mounted on the fixture portion **30**, and after the user determines the number of annular grooves on the fixture portion that will match the depth of the body cavity as measured by the indicia on the cannulated dilator and the amount necessary to hold the retractor clamp **[18]** **16**, the user with the use of the commercially available cutters **34** snips off the end of the retractor dilator **14**. The fixture will also be cut and this system for cutting assures that the dilator retractor **14** will have a clean, smooth cut. A suitable cutter **34** is one that is available in many hardware stores such as Home Depot and is under the name "Orbit". This cutter was tested and has proven to work satisfactory. However, any type of cutter is contemplated for use with this invention, such as commercially available knives and pipe cutters, being other examples.

Once the dilator retractor **14** has been cut to size the dilator retractor **14** is then fitted over the cannula dilator **10** and is forced into the body cavity with a suitable pusher tool of the type shown in FIG. **4**. Pusher tool portion **36** which in this instance is integral with the member **12** is formed on one end and includes the enlarged diameter portion **38** having a central axial bore that complements the outer diameter of the cannulated dilator **10**. The bottom annular face **40** is formed with a flat surface that bears against the end **42** of the dilator retractor **14**. This serves to provide leverage for the surgeon to push the dilator retractor **14** into the body cavity.

Also in accordance with this invention the end clamp **16** comprises an annular body **46** being split at **47** and including a threaded lateral bore that accommodates the tightening screw **50**. The central opening is dimensioned to fit over the end of the dilator retractor **14** and slide thereon. Once in position the screw is tightened to secure the clamp to the dilator retractor **14**. A bracket **56** having a bifurcated slot **58** serves to engage a flexible arm that is clamped to a rigid member. This serves to support the dilator retractor **14** while the surgeon is performing the surgical procedure.

FIG. **9** exemplifies another embodiment of this invention where the dilator retractors **14** come in a series of different sizes so that the surgeon after determining the size of the depth of the body cavity as ascertained by the graduated scale on the cannulated dilator **10**, the surgeon merely selects the size to match the body cavity depth taking into consideration the extra length needed to accommodate the clamp **16**.

6

The cannulated retractor tool **39** is a relatively rectangular flat member **41** having a central bore **43** that is made from two spaced diameters. The most inner diameter on the bottom face of the tool **39** is slightly larger than the outer diameter of the cannula dilator **10** and the outer diameter on the top face of the tool **39** is equivalent to the inner diameter of the cannulated dilator **10** to provide a shoulder for bearing on the annular top surface **45** of the cannulated dilator **10**. A pair of concentrically spaced recesses **49** are formed in the top surface extending through the upper portion of tool **40** to accommodate and complement the tabs **22**. Thus tool **39** serves to provide a leverage tool that helps the surgeon for forcing the cannulated dilator **10** into the body cavity and against the resistance created by the body tissue adjacent thereto.

FIG. **10** exemplifies another embodiment of this invention where the fixture **12a** which is identical to fixture **12** does not include the spaced annular grooves and the cannula **14a** which is identical to the cannula **14** includes indicia on the outer wall that corresponds to the indicia on the cannulated dilator **10**. As is apparent from the foregoing the user merely has to size the cannula **14a** by making a measurement of the body cavity with the cannulated dilator **10** and select the measurement corresponding thereto from the indicia on the cannula **14a**, and after the cannula is inserted onto the fixture **12a**, the user cuts the cannula **14a** and fixture **12a** so that the cannula **14a** is sized to fit the body cavity. Obviously, the cannula **14a** in this instance need not be transparent and can be opaque.

What has been described by this invention is a cannula that is sized to fit the individual patient. A cannulated dilator includes indicia of a scale for measuring the depth of the individual patient. With that measurement, the cannula in one embodiment may be made from a plastic, transparent material fits onto a fixture that is cuttable and contains a visible predetermined scale to cut the cannula to the particular length. In another embodiment the cannula includes indicia of a scale corresponding to the scale on the cannulated dilator and is similarly cut. The invention teaches a tool is provided to insert the cannulated dilator into the cavity and another tool to insert the cannula into the body cavity. In another embodiment a series of pre-sized cannulas are provided so that the user can select from this series the size that corresponds to the measurement obtained with the cannulated dilator.

Although this invention has been shown and described with respect to detailed embodiments thereof, it will be appreciated and understood by those skilled in the art that various changes in form and detail thereof may be made without departing from the spirit and scope of the claimed invention.

I claim:

**[1.** A cannulated dilator having an outer surface, said cannulated dilator for insertion into an access hole formed in a patient for stretching the tissue adjacent to the access hole so as to enlarge the same, said cannulated dilator having an elongated tubular body, a beveled portion at the distal end thereof, the improvement comprising indicia on the side outer surface of the cannulated dilator for measuring the depth of the access hole, said cannulated dilator having a proximal end and a tool engagement portion formed thereon, in combination with a tool having an engagement portion complementing the tool engagement portion of the cannulated dilator adapted to fit thereon for rotation and applying leverage on said cannulated dilator for insertion thereof into the access hole and a cannula for fitting into said access hole for permitting the performance of a medical procedure after the cannulated dilator has been removed.]

2. A cannulated dilator having an outer surface, said cannulated dilator for insertion into an access hole formed in the body of a patient for stretching the tissue adjacent the access hole and for enlarging the same, said cannulated dilator having an elongated tubular body, a beveled portion at the distal end thereof, the improvement comprising indicia on the side outer surface of the cannulated dilator for measuring the depth of the access hole, said cannulated dilator having a pair of circumferentially spaced tabs extending radially from the proximal end, in combination with a tool having a rectangularly shaped planar body, a central bore formed intermediate the ends thereof, an enlarged diameter recess extending from one face into said planar body and being concentric with said central bore but spaced from the opposite face thereof to define a shoulder, said tabs complementing recesses formed in said planar body adjacent to said enlarged diameter recess, whereby the cannulated dilator fits into said tool and said cannulated dilator engages said shoulder to permit the user to insert said cannulated dilator into said access hole and rotate same as it progresses into said access hole and a cannula for insertion into said access hole to permit a surgical procedure after the cannulated dilator has been removed.

[3. The combination of a cannulated dilator and a dilator retractor wherein said cannulated dilator includes indicia for measuring the depth of an access hole formed in a patient for medical procedure and said dilator retractor being made from a cuttable material and being dimensioned larger in length than is anticipated of any depth of said access hole of the body of any patient that is anticipated in the medical procedure, the dilator retractor being cuttable commensurate with the depth of said access hole as measured by said cannulated dilator for sizing said dilator retractor to a length that is shorter than the original length of the dilator retractor prior to being inserted into the access hole so as to be utilized for performing the medical procedure whereby said dilator retractor is sized for the anatomy of the patient.]

[4. The combination of a cannulated dilator and a dilator retractor as claimed in claim 3 wherein said dilator retractor is made from a plastic material.]

[5. The combination of a cannulated dilator and a dilator retractor as claimed in claim 4 wherein said dilator retractor is made from a transparent material.]

[6. The combination of a cannulated dilator and dilator retractor as claimed in claim 3 including an annular clamp, said clamp being dimensioned to fit said dilator retractor and means including a bracket extending from said annular clamp adapted to support the dilator retractor to a rigid member.]

[7. The combination of a cannulated dilator and dilator retractor as claimed in claim 6 wherein said clamp is split through a portion thereof to define a gap between the ends adjacent the split, an adjustment for enlarging or decreasing said gap and the inner diameter portion surrounding the dilator retractor for securing said annular clamp to the dilator retractor and including means adapted to support the dilator retractor to a rigid member.]

[8. The combination of a cannulated dilator and dilator retractor as claimed in claim 6 including an elongated fixture having a circular cross section and made from a cuttable plastic material, and means to cut said dilator retractor an amount commensurate with the measurement attained by said cannulated retractor and the width of said annular clamp.]

9. [The combination of a cannulated dilator and dilator retractor as claimed in claim 8] *The combination of a cannulated dilator and a dilator retractor wherein said cannulated*

*dilator includes indicia for measuring the depth of an access hole formed in a patient for medical procedure and said dilator retractor being made from a cuttable material and being dimensioned larger in length than is anticipated of any depth of said access hole of the body of any patient that is anticipated in the medical procedure, the dilator retractor being cuttable commensurate with the depth of said access hole as measured by said cannulated dilator for sizing said dilator retractor to a length that is shorter than the original length of the dilator retractor prior to being inserted into the access hole so as to be utilized for performing the medical procedure whereby said dilator retractor is sized for the anatomy of the patient,*

*including an annular clamp, said clamp being dimensioned to fit said dilator retractor and means including a bracket extending from said annular clamp adapted to support the dilator retractor to a rigid member,*

*including an elongated fixture having a circular cross section and made from a cuttable plastic material, and means to cut said dilator retractor an amount commensurate with the measurement attained by said cannulated retractor and the width of said annular clamp,*

wherein said elongated fixture includes a series of axially spaced grooves spaced a predetermined amount, said dilator retractor being transparent and fitting over said elongated fixture for the spaced grooves to be visible wherein the selection of said annular grooves determines the length of the dilator retractor to be cut.

10. [The combination of a cannulated dilator and dilator retractor as claimed in claim 3] *The combination of a cannulated dilator and a dilator retractor wherein said cannulated dilator includes indicia for measuring the depth of an access hole formed in a patient for medical procedure and said dilator retractor being made from a cuttable material and being dimensioned larger in length than is anticipated of any depth of said access hole of the body of any patient that is anticipated in the medical procedure, the dilator retractor being cuttable commensurate with the depth of said access hole as measured by said cannulated dilator for sizing said dilator retractor to a length that is shorter than the original length of the dilator retractor prior to being inserted into the access hole so as to be utilized for performing the medical procedure whereby said dilator retractor is sized for the anatomy of the patient,*

*including a pusher tool having an elongated circular body, a central bore having a dimension to complement the outer diameter of said cannulated dilator, and a bottom surface overlying the end of said dilator retractor so that when said pusher tool is pushed into the body cavity the dilator retractor is forced into the body cavity and the central bore slides over said cannulated dilator.*

11. The combination of a cannulated dilator and dilator retractor as claimed in claim 10 wherein said pusher tool is integral with said elongated [fixture] *circular body.*

12. The combination of a cannulated dilator and dilator retractor, said cannulated dilator being [in the] *last in a series of [the last] cannulated [dilator] dilators* for enlarging the access hole in the body of a patient, at least one of said cannulated dilators having an elongated body, indicia on said elongated body indicative of a measurement of depth for measuring the depth of the access hole, said dilator retractor including a series of dilator retractors each having different lengths, whereby the dilator retractor for use in the access hole is selected from said series of dilator retractors that is commensurate with the measurement of said [cannula(d)] *cannulated dilator* as obtained from said indicia when inserted into said access hole for defining a working space

for performing a medical procedure when the cannulated dilator has been removed.

13. The method of sizing the length of a cannula to fit the depth of an access hole formed in the body of a patient including the steps of:

- i. providing a cannula that is oversized in length;
- ii. providing a cannulated dilator that is [in the] last [of] in a series of cannulated dilators used for enlarging the access hole with indicia of a scale for measuring a length;
- iii. measuring the depth of the access hole by inserting the cannulated dilator obtained in the step of providing a cannulated dilator into the access hole to ascertain the depth;
- iv. cutting the cannula to the size obtained in the step of measuring before being inserted into the access hole; and
- v. inserting the cannula obtained in the step of cutting into the access hole over the cannulated dilator and removing the cannulated dilator to define a working space to perform a medical procedure.

14. The method as claimed in claim 13 including the step of providing a template made from a cuttable material that is dimensioned to fit into the cannula;

- i. inserting the template into the cannula;
- ii. cutting the cannula and template at the length commensurate with the access hole.

15. The method as claimed in claim 14 including the provision of including markings on said template graduated to a scale commensurate with the scale of the indicia on the cannulated dilator; and the cannula being transparent so that the scale on the fixture is visible.

16. The method as claimed in claim 14 including a clamp to fit the end of the cannula; cutting in the step of cutting the cannula to a length that includes the width of the clamp.

17. The method as claimed in claim 14 including the step of providing a tool for engaging the proximal end of the cannulated dilator and inserting the cannulated dilator by pushing and turning the tool.

18. The method as claimed in claim 14 including the step of providing a tool for engaging said cannula for pushing said cannula into the access hole.

19. The method of sizing the length of a cannula to fit the depth of an access hole formed in the body of a patient including the steps of:

- i. providing a series of different length cannulas;
- ii. providing a cannulated dilator with indicia of a scale for measuring a length;
- iii. measuring the depth of the access hole by inserting the cannulated dilator into the access hole to ascertain the depth;
- iv. selecting from said different length cannulas obtained in the step of providing a series of different length cannulas the length correlating to the length obtained in the step of measuring before inserting said selected cannula; and
- v. inserting said the cannula obtained in the step of selecting from said different length cannulas into said access hole for defining a working chamber for performing the medical procedure.

20. The combination of a cannulated dilator and dilator retractor as claimed in claim 12 including an annular clamp, said clamp being dimensioned to fit any of said dilator retractor from said series of said dilator retractors and a bracket extending from said annular clamp adapted to support the dilator retractor to a rigid member.

21. The combination of a cannulated dilator and dilator retractor as claimed in claim 12 wherein each of said cannulated dilator has a proximal end and a tool engagement portion formed thereon, a tool having an engagement portion complementing the tool engagement portion of the cannulated dilator adapted to fit thereon for rotation and applying leverage on said cannulated dilator for insertion thereof into the body cavity.

22. The combination of a cannulated dilator and dilator retractor, said cannulated dilator having an elongated body, said cannulated dilator for obtaining the measurement of depth of an access hole formed in a body, said dilator retractor including a series of dilator retractors having different lengths, whereby the dilator retractor for use in the access hole is selected from said series of dilator retractors that is commensurate with the measurement obtained from said cannulated dilator when extended into said access hole.]

23. The combination of a cannulated dilator and dilator retractor as claimed in claim 12 wherein said dilator retractor is made [form] from a plastic material.

24. The combination of a cannulated dilator and dilator retractor as claimed in claim 23 wherein said dilator [retractor] retractor is made [form] from a transparent material.

25. *The method of sizing the length of a cannula to fit the depth of an access hole formed in the body of a patient including the steps of:*

- i. providing a series of different length cannulas;
- ii. providing a measurement instrument for measuring a length;
- iii. measuring the depth of the access hole by the instrument obtained in the previous step ii;
- iv. selecting from said different length cannulas obtained in the step of providing a series of different length cannulas the length correlating to the length obtained in the step of measuring before inserting said selected cannula; and
- v. inserting said the cannula obtained in the step of selecting from said different length cannulas into said access hole for defining a working chamber for performing the medical procedure.

26. *A method of surgically creating a working channel in a patient through which to conduct a surgical procedure, comprising:*

- sequentially inserting a series of dilators into a patient to form an access hole, at least one of the dilators having indicia formed thereon for measuring a depth of the access hole;*
- inserting a cannula over the dilators, the cannula having a length that is commensurate with the measured depth of the access hole; and*
- removing the dilators from the cannula to provide a working channel through the cannula.*

27. *The method of claim 26, wherein the access hole extends to vertebral disc space.*

28. *The method of claim 26, wherein the dilators are cannulated and they are inserted over a guidewire.*

29. *The method of claim 26, wherein, prior to the step of inserting a cannula over the dilators, the cannula is cut to have a length that is commensurate with the measured depth of the access hole.*

30. *The method of claim 26, wherein the cannula is selected from a series of cannulas having different lengths.*

31. *A method of surgically creating a working channel in a patient through which to conduct a surgical procedure, comprising:*

## 11

*forming an access hole in a patient using a series of dilators;*

*measuring a depth of the access hole using one of the dilators:*

*inserting a cannula over the dilators, the cannula having a length that is commensurate with the measured depth of the access hole; and*

*removing the dilators from the cannula to provide a working channel through the cannula.*

32. *The method of claim 31, wherein the step of forming an access hole in a patient using a series of dilators comprises inserting a guide wire into the patient and sequentially inserted a series of cannulated dilators over the guidewire to create an access hole.*

33. *The method of claim 31, wherein, prior to the step of inserting a cannula over the dilators, the cannula is cut to have a length that is commensurate with the measured depth of the access hole.*

## 12

34. *The method of claim 31, wherein the cannula is selected from a series of cannulas having different lengths.*

35. *A method of surgically creating a working channel in a patient through which to conduct a surgical procedure, comprising:*

*inserting a first dilator into a patient;*

*inserting one or more cannulated dilators over the first dilator to form an access hole in the patient;*

*measuring a depth of the access hole using one of the dilators;*

*inserting a cannula over the dilators, the cannula having a length that is commensurate with the measured depth of the access hole; and*

*removing the dilators from the cannula to provide a working channel through the cannula.*

\* \* \* \* \*

UNITED STATES PATENT AND TRADEMARK OFFICE  
**CERTIFICATE OF CORRECTION**

PATENT NO. : RE42,525 E  
APPLICATION NO. : 10/165991  
DATED : July 5, 2011  
INVENTOR(S) : Simonson

Page 1 of 1

It is certified that error appears in the above-identified patent and that said Letters Patent is hereby corrected as shown below:

Column 1, Line 8, above the heading, "TECHNICAL FIELD" insert: -- Notice: More than one reissue application has been filed for the reissue of U.S. Patent No. 6,159,179. The reissue applications are U.S. Reissue Patent Application Serial No. 14/715,285, filed on May 18, 2015, which is a continuation reissue application of U.S. Reissue Patent Application Serial No. 12/971,929, filed on December 17, 2010, now U.S. Reissue Patent No. RE45,571 E, which is a continuation reissue application of U.S. Reissue Patent Application Serial No. 10/165,991 (the present application), filed on June 10, 2002, now U.S. Reissue Patent No. RE42,525 E. --.

Signed and Sealed this  
Twenty-ninth Day of May, 2018

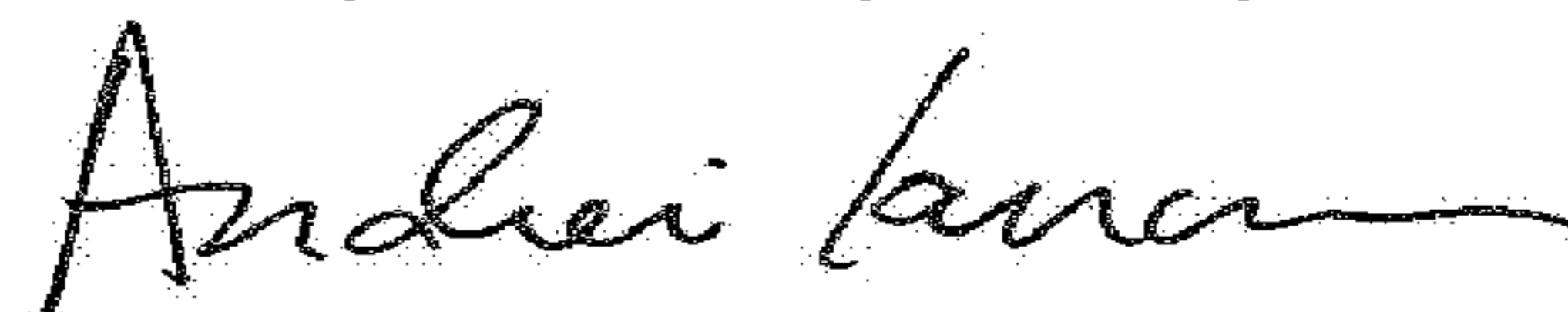

Andrei Iancu  
*Director of the United States Patent and Trademark Office*