

US00RE42480E

(19) **United States**  
(12) **Reissued Patent**  
**Bryan et al.**

(10) **Patent Number:** **US RE42,480 E**  
(45) **Date of Reissued Patent:** **Jun. 21, 2011**

(54) **HUMAN SPINAL DISC PROTHESIS WITH HINGES**  
(75) Inventors: **Vincent Bryan**, Quincy, WA (US); **Alex Kunzler**, La Quinta, CA (US)  
(73) Assignee: **Warsaw Orthopedic, Inc.**, Warsaw, IN (US)

3,875,595 A 4/1975 Froning  
3,876,728 A 4/1975 Stubstad  
4,023,572 A 5/1977 Weigand et al.  
4,116,200 A 9/1978 Braun et al.  
4,179,810 A 12/1979 Kirsch  
4,309,777 A \* 1/1982 Patil ..... 623/17.13  
(Continued)

(\*) Notice: This patent is subject to a terminal disclaimer.

DE 2 263 842 \* 7/1974  
(Continued)

(21) Appl. No.: **10/017,611**

**OTHER PUBLICATIONS**

(22) Filed: **Dec. 14, 2001**

“The Occurrence of Optic Neuritis in Lesions of the Spinal Cord, Injury, Tumor, Melitis;” Taylor, Collier, Brain: A Journal of Neurology; vol. 24; MacMillan & Co. Ltd., 1901; pp. 532-550.\*

**Related U.S. Patent Documents**

Reissue of:

(64) Patent No.: **6,001,130**  
Issued: **Dec. 14, 1999**  
Appl. No.: **08/944,378**  
Filed: **Oct. 6, 1997**

(Continued)

U.S. Applications:

(63) Continuation-in-part of application No. 08/681,230, filed on Jul. 22, 1996, now Pat. No. 5,674,296, which is a continuation-in-part of application No. 08/339,490, filed on Nov. 14, 1994, now abandoned.

*Primary Examiner* — David H Willse  
*Assistant Examiner* — Javier G Blanco

(51) **Int. Cl.**  
**A61F 2/44** (2006.01)

(52) **U.S. Cl.** ..... **623/17.16; 623/17.11; 623/17.13; 606/247**

(58) **Field of Classification Search** ..... **623/17.11, 623/17.12, 17.13, 17.14, 17.15, 17.16; 606/60, 606/61, 70, 71, 72, 73**

See application file for complete search history.

(57) **ABSTRACT**

The invention relates to a spinal disc endoprosthesis. The endoprosthesis has a resilient body formed of one or more materials which may vary in stiffness from a relatively stiff exterior annular gasket portion to a relatively supple central nucleus portion. Concaval-convex elements at least partly surround that nucleus portion so as to retain the nucleus portion and gasket between adjacent vertebral bodies in a patient's spine. Assemblies of endoprosthetic discs, endoprosthetic vertebral bodies, and endoprosthetic longitudinal ligaments may be constructed. To implant this endoprosthesis assembly, information is obtained regarding the size, shape, and nature of a patient's damaged spine. Thereafter, one or more prosthetic vertebral bodies and disc units are constructed in conformity with that information. Finally, the completed and conformed vertebral body and disc assembly is implanted in the patient's spine.

(56) **References Cited**

**U.S. PATENT DOCUMENTS**

2,677,369 A \* 5/1954 Knowles ..... 606/61  
3,486,505 A 12/1969 Morrison

**22 Claims, 10 Drawing Sheets**

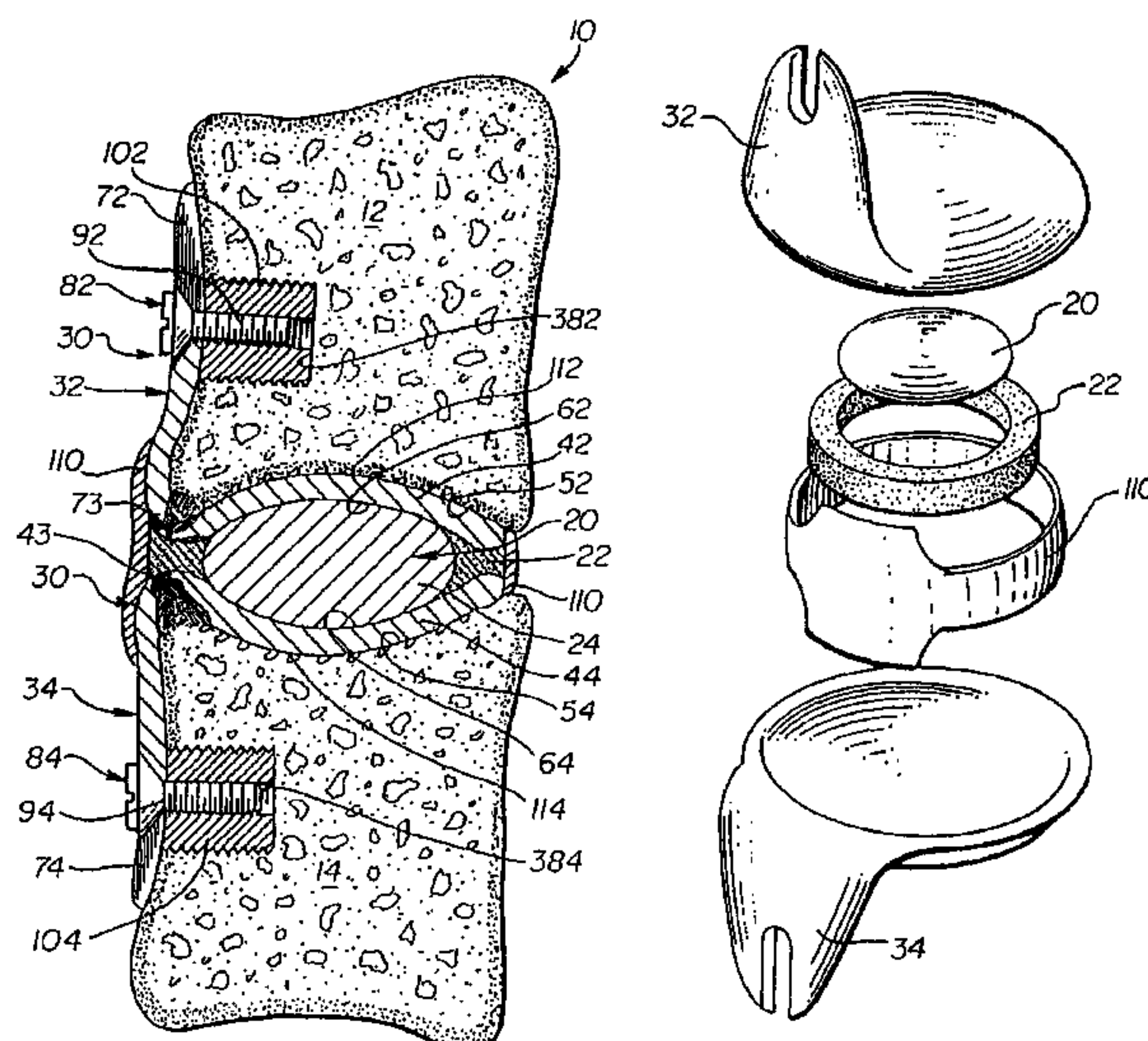



# US RE42,480 E

Page 2

## U.S. PATENT DOCUMENTS

4,349,921 A 9/1982 Kuntz  
 4,599,086 A \* 7/1986 Doty ..... 606/61  
 4,645,507 A 2/1987 Engelbrecht et al.  
 4,714,469 A 12/1987 Kenna  
 4,743,256 A 5/1988 Brantigan  
 4,757,983 A 7/1988 Ray et al.  
 4,759,766 A \* 7/1988 Buettner-Janz et al. ... 623/17.15  
 4,759,769 A \* 7/1988 Hedman et al. .... 623/17.13  
 4,766,328 A 8/1988 Yang  
 4,777,942 A 10/1988 Frey et al.  
 4,800,639 A 1/1989 Frey et al.  
 4,834,757 A 5/1989 Brantigan  
 4,863,476 A 9/1989 Shepperd  
 4,863,477 A 9/1989 Monson  
 4,874,389 A 10/1989 Downey  
 4,878,915 A 11/1989 Brantigan  
 4,887,595 A 12/1989 Heinig et al.  
 4,904,260 A 2/1990 Ray et al.  
 4,904,261 A 2/1990 Dove et al.  
 4,908,032 A 3/1990 Keller  
 4,908,036 A 3/1990 Link et al.  
 4,911,718 A \* 3/1990 Lee et al. .... 623/17.15  
 4,917,704 A \* 4/1990 Frey et al. .... 623/17.16  
 4,932,969 A \* 6/1990 Frey et al. .... 623/17.12  
 4,932,975 A 6/1990 Main et al.  
 4,946,378 A 8/1990 Hirayama et al.  
 4,955,908 A \* 9/1990 Frey et al. .... 623/17.16  
 4,978,355 A 12/1990 Frey et al.  
 4,997,432 A \* 3/1991 Keller ..... 606/61  
 5,002,576 A \* 3/1991 Fuhrmann et al. .... 623/17.15  
 5,015,247 A 5/1991 Michelson  
 5,035,716 A 7/1991 Downey  
 5,047,055 A 9/1991 Bao et al.  
 5,059,193 A 10/1991 Kuslich  
 5,059,194 A 10/1991 Michelson  
 5,062,845 A 11/1991 Kuslich et al.  
 5,071,437 A \* 12/1991 Steffee ..... 623/17.16  
 5,080,662 A 1/1992 Paul  
 5,084,048 A 1/1992 Jacob et al.  
 5,108,438 A 4/1992 Stone  
 5,122,130 A \* 6/1992 Keller ..... 606/61  
 5,123,926 A 6/1992 Pisharodi  
 5,171,280 A 12/1992 Baumgartner  
 5,171,281 A \* 12/1992 Parsons et al. .... 623/17.15  
 5,176,708 A 1/1993 Frey et al.  
 5,192,326 A \* 3/1993 Bao et al. .... 623/17.12  
 5,192,327 A 3/1993 Brantigan  
 5,234,431 A \* 8/1993 Keller ..... 606/70  
 5,236,460 A 8/1993 Barber  
 5,258,031 A \* 11/1993 Salib et al. .... 623/17.15  
 5,261,911 A \* 11/1993 Carl ..... 606/61  
 5,261,913 A 11/1993 Marnay  
 5,306,307 A \* 4/1994 Senter et al. .... 623/17.16  
 5,306,308 A \* 4/1994 Gross et al. .... 623/17.16  
 5,314,477 A \* 5/1994 Marnay ..... 623/17.15  
 5,314,478 A 5/1994 Oka et al.  
 5,320,644 A 6/1994 Baumgartner  
 5,370,697 A \* 12/1994 Baumgartner ..... 623/17.15  
 5,383,933 A 1/1995 Keller  
 5,401,269 A \* 3/1995 Buttner-Janz et al. .... 623/17.15  
 5,403,314 A 4/1995 Currier  
 5,425,772 A 6/1995 Brantigan  
 5,425,773 A 6/1995 Boyd et al.  
 5,443,514 A 8/1995 Steffee  
 5,456,719 A 10/1995 Keller  
 5,458,638 A 10/1995 Kuslich et al.  
 5,458,642 A \* 10/1995 Beer et al. .... 623/17.13  
 5,484,437 A 1/1996 Michelson  
 5,489,307 A 2/1996 Kuslich et al.  
 5,489,308 A 2/1996 Kuslich et al.  
 5,496,318 A 3/1996 Howland et al.  
 5,507,816 A 4/1996 Bullivant  
 5,514,180 A 5/1996 Heggeness et al.  
 5,527,315 A 6/1996 Jeanson et al.  
 5,534,028 A 7/1996 Bao et al.  
 5,534,029 A \* 7/1996 Shima ..... 623/17.15  
 5,545,229 A 8/1996 Parsons et al.  
 5,556,431 A \* 9/1996 Buttner-Janz ..... 623/17.15

5,562,738 A 10/1996 Boyd et al.  
 5,575,815 A \* 11/1996 Slepian et al. .... 600/36  
 5,593,409 A 1/1997 Michelson  
 5,609,636 A 3/1997 Kohrs et al.  
 5,645,598 A 7/1997 Brosnahan  
 5,649,926 A 7/1997 Howland  
 5,658,285 A 8/1997 Marnay et al.  
 5,662,158 A 9/1997 Caldarise  
 5,674,294 A \* 10/1997 Bainville et al. .... 623/17.16  
 5,674,295 A 10/1997 Ray et al.  
 5,674,296 A \* 10/1997 Bryan et al. .... 623/17.16  
 5,683,464 A 11/1997 Wagner et al.  
 5,702,450 A 12/1997 Bisserie  
 5,713,899 A 2/1998 Marnay et al.  
 5,716,415 A 2/1998 Steffee  
 5,720,748 A 2/1998 Kuslich et al.  
 5,722,977 A 3/1998 Wilhelmy  
 5,723,013 A 3/1998 Jeanson et al.  
 5,741,253 A 4/1998 Michelson  
 5,782,830 A 7/1998 Farris  
 5,782,832 A 7/1998 Larsen et al.  
 5,797,909 A 8/1998 Michelson  
 5,824,093 A 10/1998 Ray et al.  
 5,824,094 A 10/1998 Serhan et al.  
 5,865,846 A 2/1999 Bryan et al.  
 5,865,848 A 2/1999 Baker  
 5,885,300 A 3/1999 Tokuhashi et al.  
 5,888,197 A 3/1999 Mulac et al.  
 5,888,226 A 3/1999 Rogozinski  
 5,897,087 A 4/1999 Farley  
 5,899,942 A \* 5/1999 Berman ..... 623/22.17  
 5,902,233 A 5/1999 Farley et al.  
 5,928,284 A 7/1999 Mehdizadeh  
 5,947,971 A 9/1999 Kuslich et al.  
 5,976,187 A 11/1999 Richelsoph  
 5,984,865 A 11/1999 Farley et al.  
 5,989,291 A 11/1999 Ralph et al.  
 6,001,130 A 12/1999 Bryan et al.  
 6,017,008 A 1/2000 Farley  
 6,022,376 A 2/2000 Assell  
 6,033,363 A 3/2000 Farley et al.  
 6,059,790 A 5/2000 Sand et al.  
 6,059,829 A 5/2000 Schlapfer et al.  
 6,063,121 A 5/2000 Xavier et al.  
 6,066,174 A 5/2000 Farris  
 6,080,155 A 6/2000 Michelson  
 6,083,228 A 7/2000 Michelson  
 6,086,595 A 7/2000 Yonemura et al.  
 6,096,038 A 8/2000 Michelson  
 6,139,579 A 10/2000 Steffee et al.  
 6,156,067 A 12/2000 Bryan et al.  
 6,162,252 A 12/2000 Kuras et al.  
 6,179,874 B1 1/2001 Cauthen  
 6,228,022 B1 5/2001 Friesem et al.  
 6,228,026 B1 5/2001 Rullo et al.  
 6,231,609 B1 5/2001 Mehdizadeh

## FOREIGN PATENT DOCUMENTS

DE 2804936 8/1979  
 DE 3 023 353 \* 4/1981  
 DE 37 41 493 A1 6/1989  
 DE 90 00 094.3 4/1990  
 EP 0176728 \* 4/1986  
 EP 000560140 A1 \* 9/1993  
 RU 1560184 A1 \* 4/1990  
 RU 895433 \* 1/1992  
 WO WO 00/04839 2/2000  
 WO WO 00/04851 3/2000  
 WO WO 00/13619 3/2000  
 WO WO 00/13620 3/2000

## OTHER PUBLICATIONS

“The Results of Anterior Interbody Fusion of the Cervical Spine;”  
 Robinson et al; The Journal of Bone & Joint Surgery; vol. 44-A, No.  
 8, Dec. 1962; pp. 1569-1587.\*  
 “Natural History & Prognosis of Cervical Spondylosis;” Lees et al.;  
 British Medical Journal; Dec. 28, 1963; British Medical Association,  
 London, England; Copyright 1963; pp. 1607-1610.\*

“The Neurological Manifestations of Cervical Spondylosis;” Brain et al; Brain, Journal of Neurology; vol. 75; MacMillan & Co.; 1952; pp. 187-225.\*

“Cervical Disc Disease;” Simeone and Rothman; Pennsylvania Hospital & University of Pennsylvania; 1975; pp. 387-433.\*

“Failed Back Surgery Syndrome;” Long; Neurosurgery Clinics of North America; vol. 2, No. 4; Oct. 1991; pp. 899-919.\*

“Far Lateral Lumbar Disc Herniations;” Hodd; Neurosurgery Clinics of North America; vol. 4, No. 1; Jan. 1993; pp. 117-124.\*

“Artificial Disc Replacement;” Enker et al; Spine; vol. 18; No. 8; 1993; pp. 1061-1070.\*

“Design of an Intervertebral Disc Prothesis;” Hedman et al; Spine; vol. 17; No. 6; 1991; pp. S256-S260.\*

“Wear Studies for Development of an Intervertebral Disc Prosthesis;” Hellier et al; Spine; vol. 17; No. 6; 1989; pp. S86-S96.\*

“Biomechanics of the SB Charite Lumbar Intervertebral Disc Endoprosthesis;” Buttner-Janz et al; International Orthopaedics; vol. 13; 1989; pp. 173-176.\*

“Finite-Element Modeling of the Synthetic Intervertebral Disc;” Langrana et al; Spine; vol. 16; No. 6; 1991; pp. S245-S252.\*

“Development of a Prosthetic Intervertebral Disc;” Lee et al; Spine; vol. 16; No. 6; 1991; pp. S253-S255.\*

“Lumbar Intervertebral Disc Prosthesis;” Tie-sheng et al; Chinese Medical Journal, 104-(5); 1991; pp. 381-386.\*

“Protesi Somatica Cervicale;” Solini et al; Ingegneria Ricostruttiva D’Avanguardia; Howmedica International; Pfizer; Italy.\*

“Metal Cementless Prosthesis for Vertebral Body Replacement of Metastatic Malignant Disease of the Cervical Spine;” Solini et al; Journal of Spinal Disorders; vol. 2; No. 4; 1989; pp. 254-262.\*

Wear Studies for Development of an Intervertebral Disc Prosthesis; Hellier et al; Spine; vol. 17; No. 6 Supplement; 1992; pp. S86-S96.\*

“Some Additional Suggestions for an Intervertebral Disc Prosthesis;” Edeland; Dept. of Occupational Health; Vdvo PV AB; S40508; Goteborg; Sweden; 1985 Butterworth & Co. Publishers Ltd.\*

“Shear Stability of an Elastomeric Disc Spacer Within an Intervertebral Joint: A Parametric Study;” Hawkins et al; Journal of Biomechanical Engineering Technical Briefs; vol. 114; Aug. 1992; pp. 414-415.\*

“The Artificial Disc—Introduction, History and Socioeconomics;” Ray; Clinical Efficacy and Outcome in the Diagnosis and Treatment of Low Back Pain; Raven Press, Ltd.; NY; 1992; pp. 205-280.\*

Artificial Disc, Market Potential and Technology Update, Viscogliosi Bros., LLC, Feb. 2000, pp. 1-65.

Boning-Up, The Musculoskeletal Healthcare Industry, Industry Commentary & Review of 1999, Viscogliosi Bros., LLC, Mar. 10, 2000, pp. 1-33.

Bryan Total Cervical Disc Prosthesis, Single Level Surgical Technique Manual, SPINALdynamics Corporation, 2000, 01080-004, pp. 29.

Morphology of the Human Skeleton, pp. 268270; 283-291; 315-331; 489-495.

Spine Industry Dynamics, Viscogliosi Bros., LLC, Mar. 10, 2000, pp. 1-4.

International Search Report—PCT/US01/24791.

\* cited by examiner



FIG. 1

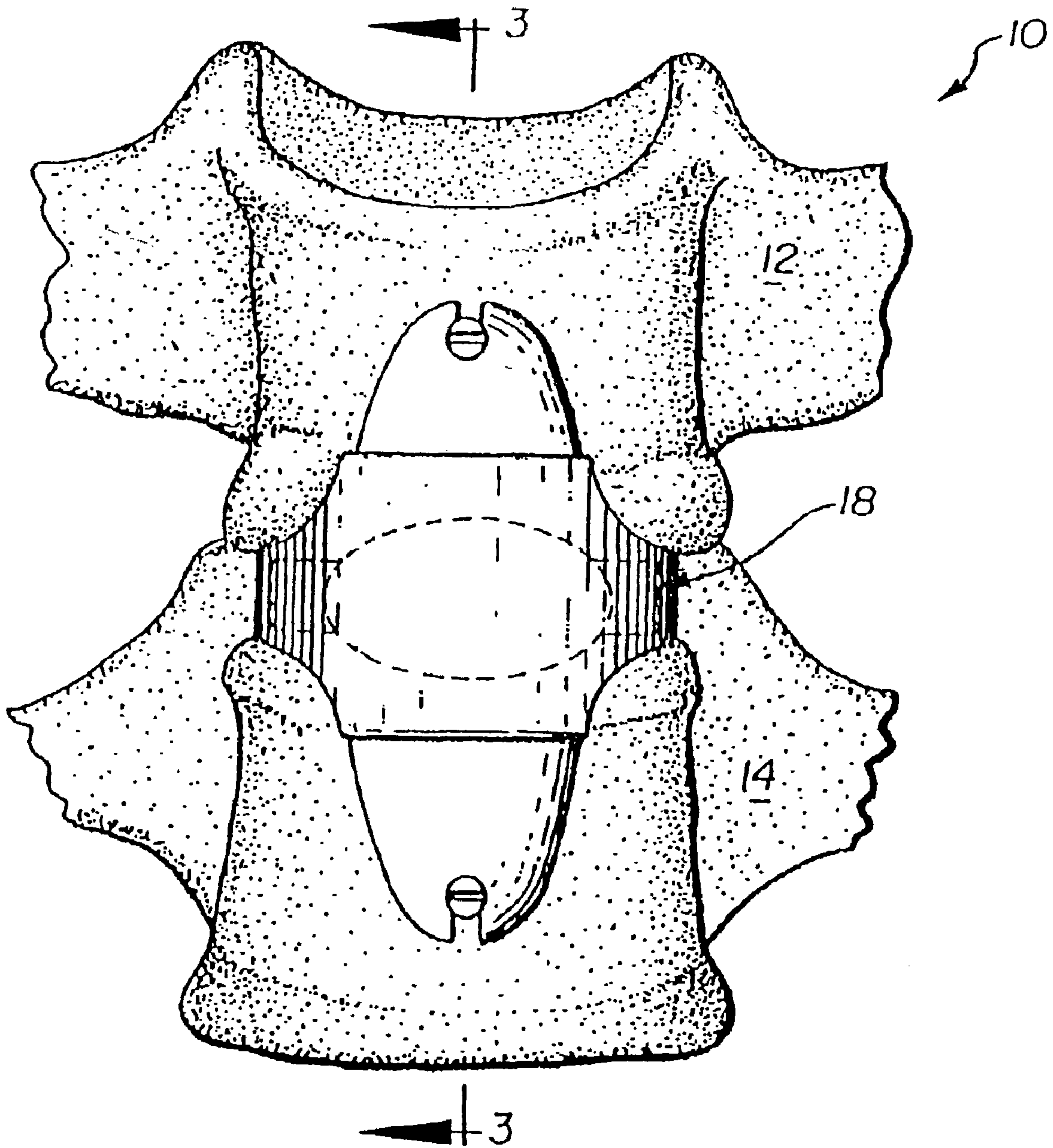

FIG. 2

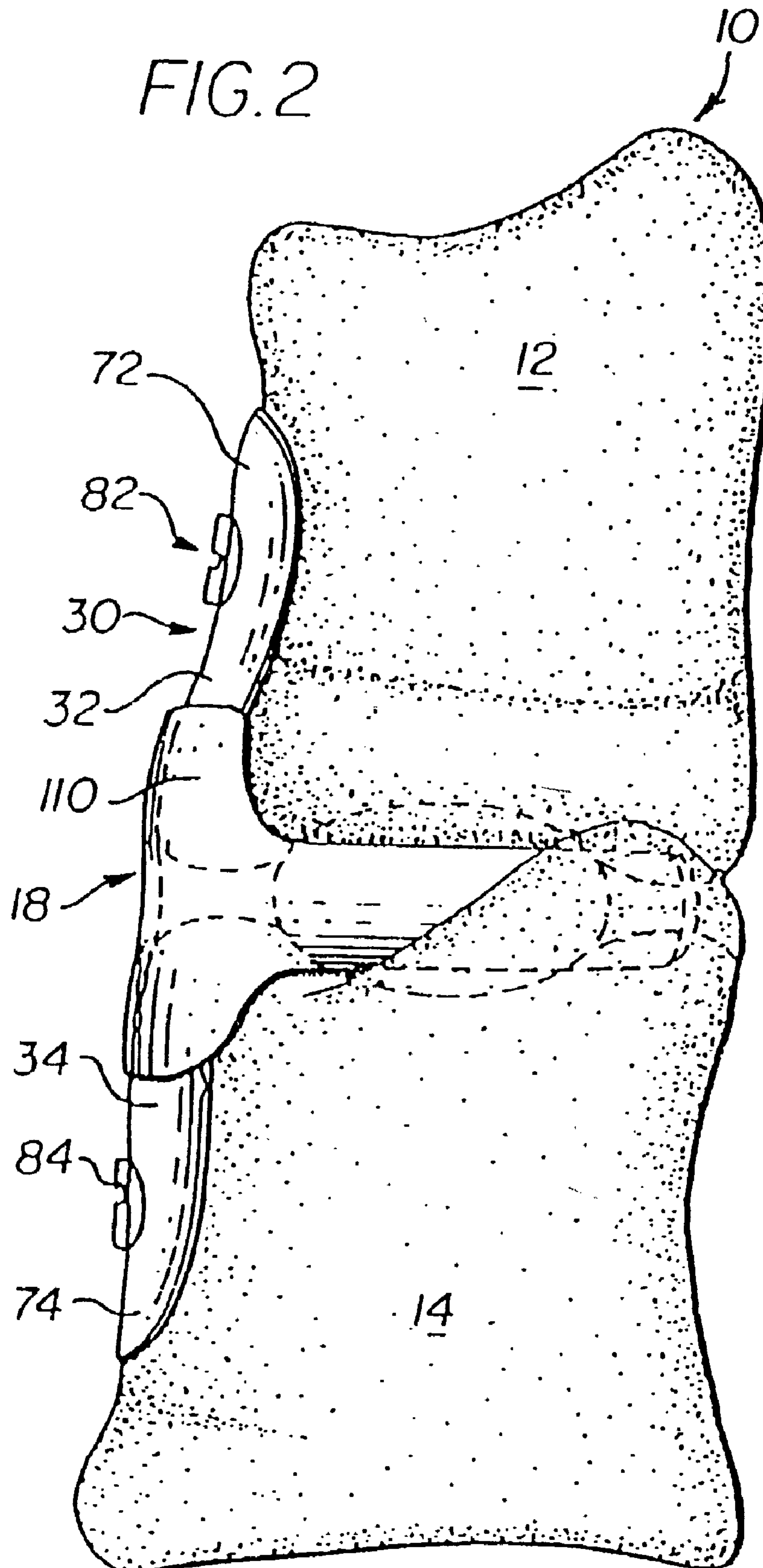

FIG. 3

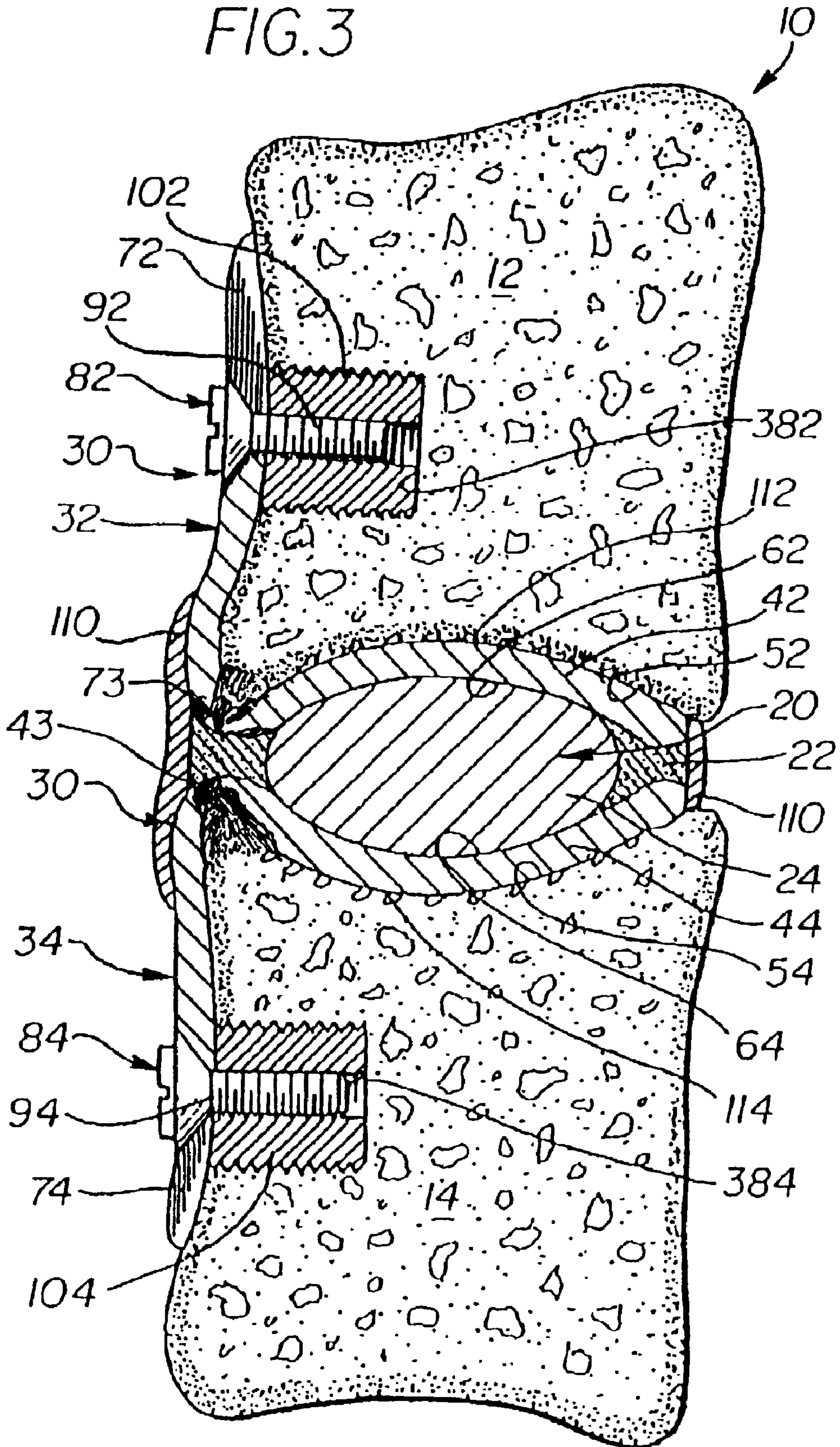

FIG. 4

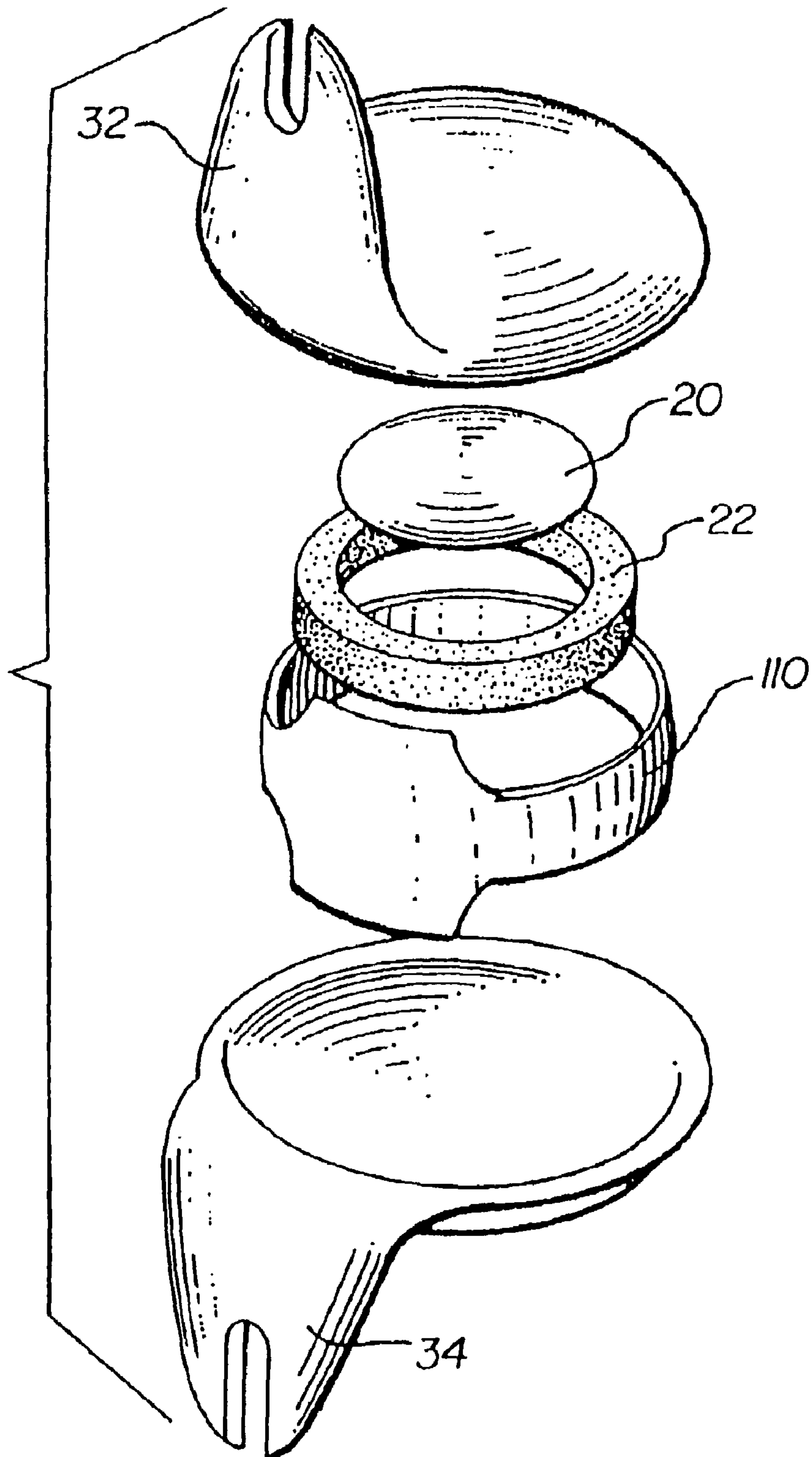



FIG. 5

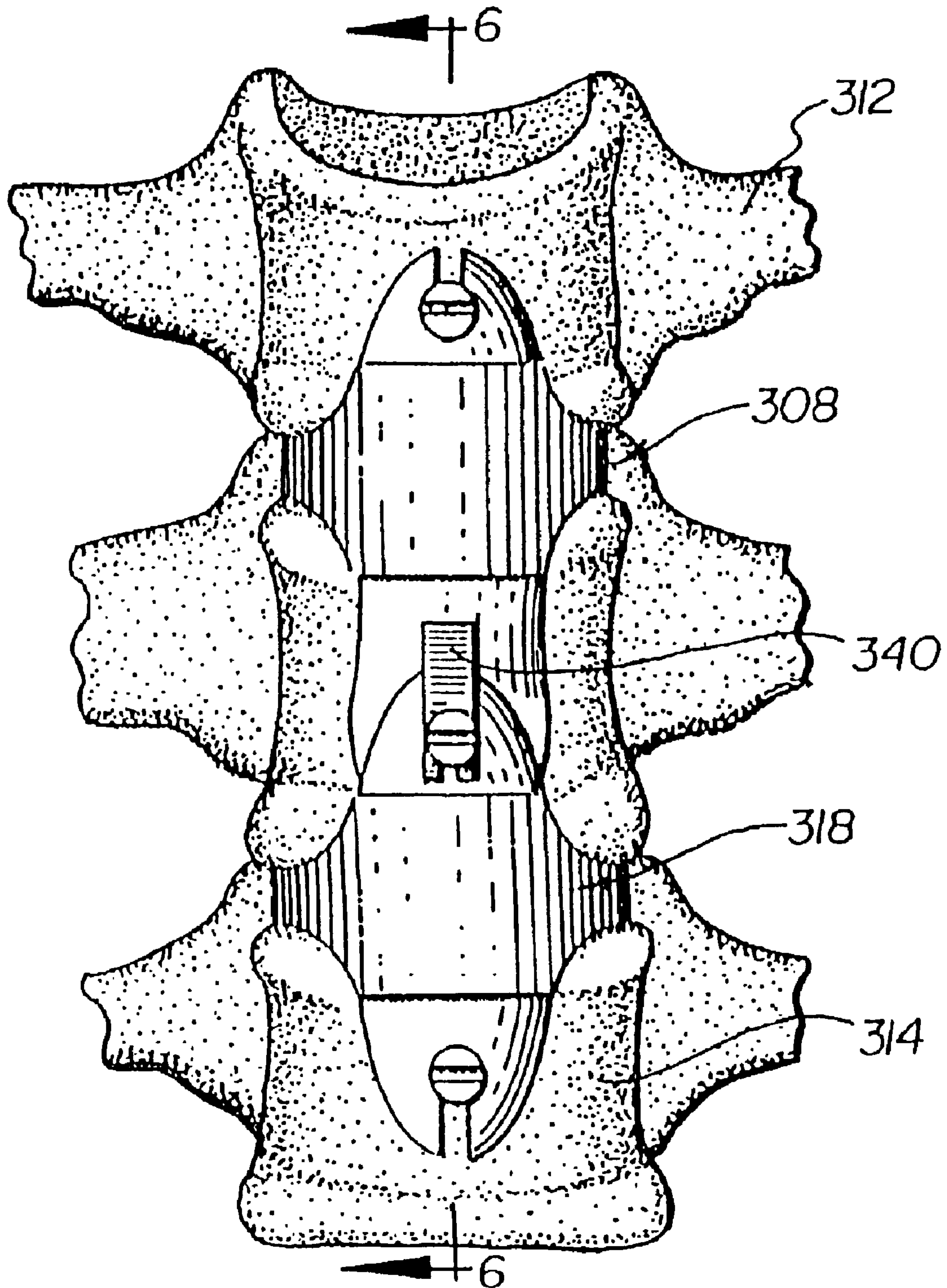



FIG. 6

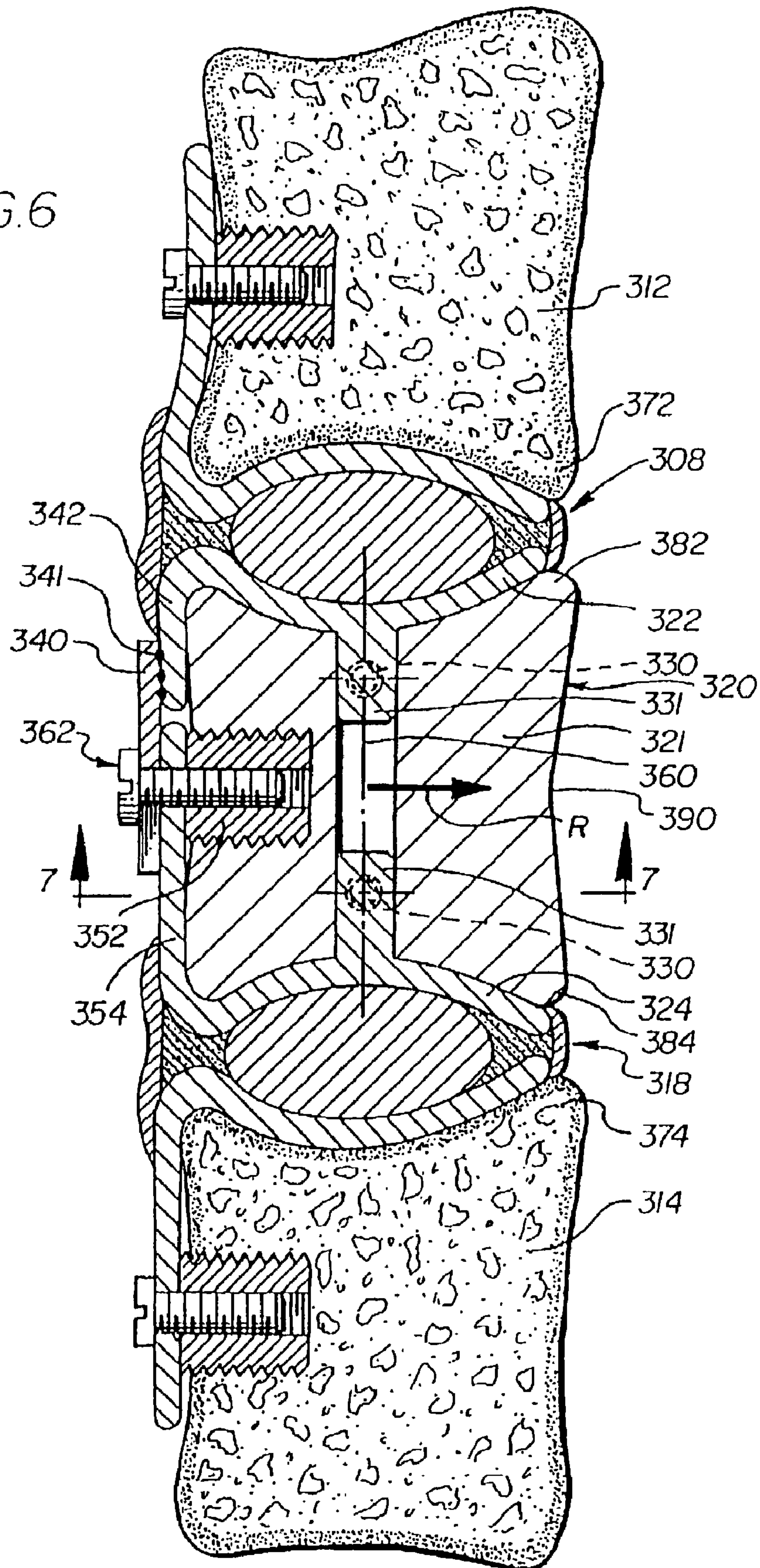

FIG. 7

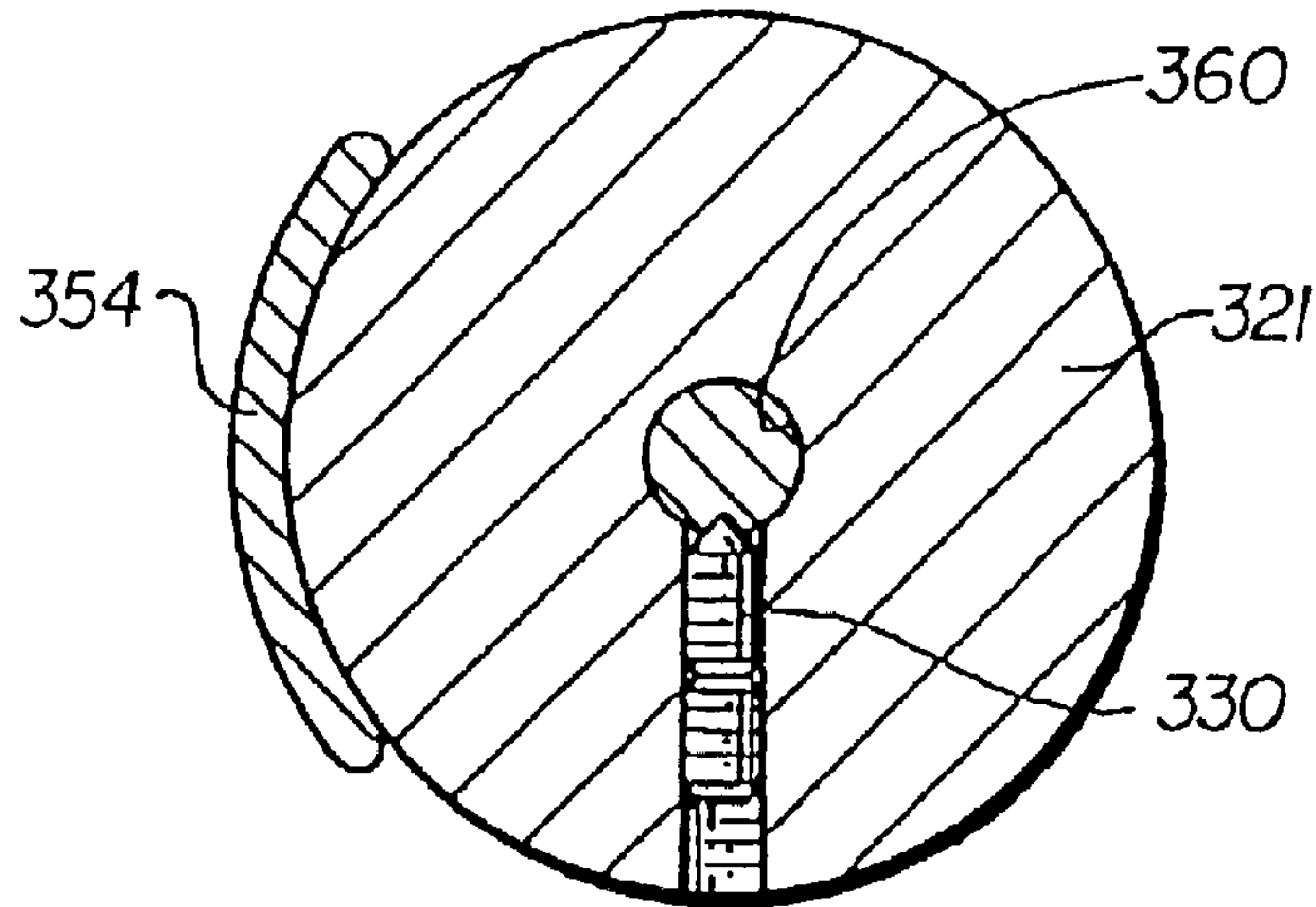

FIG. 8

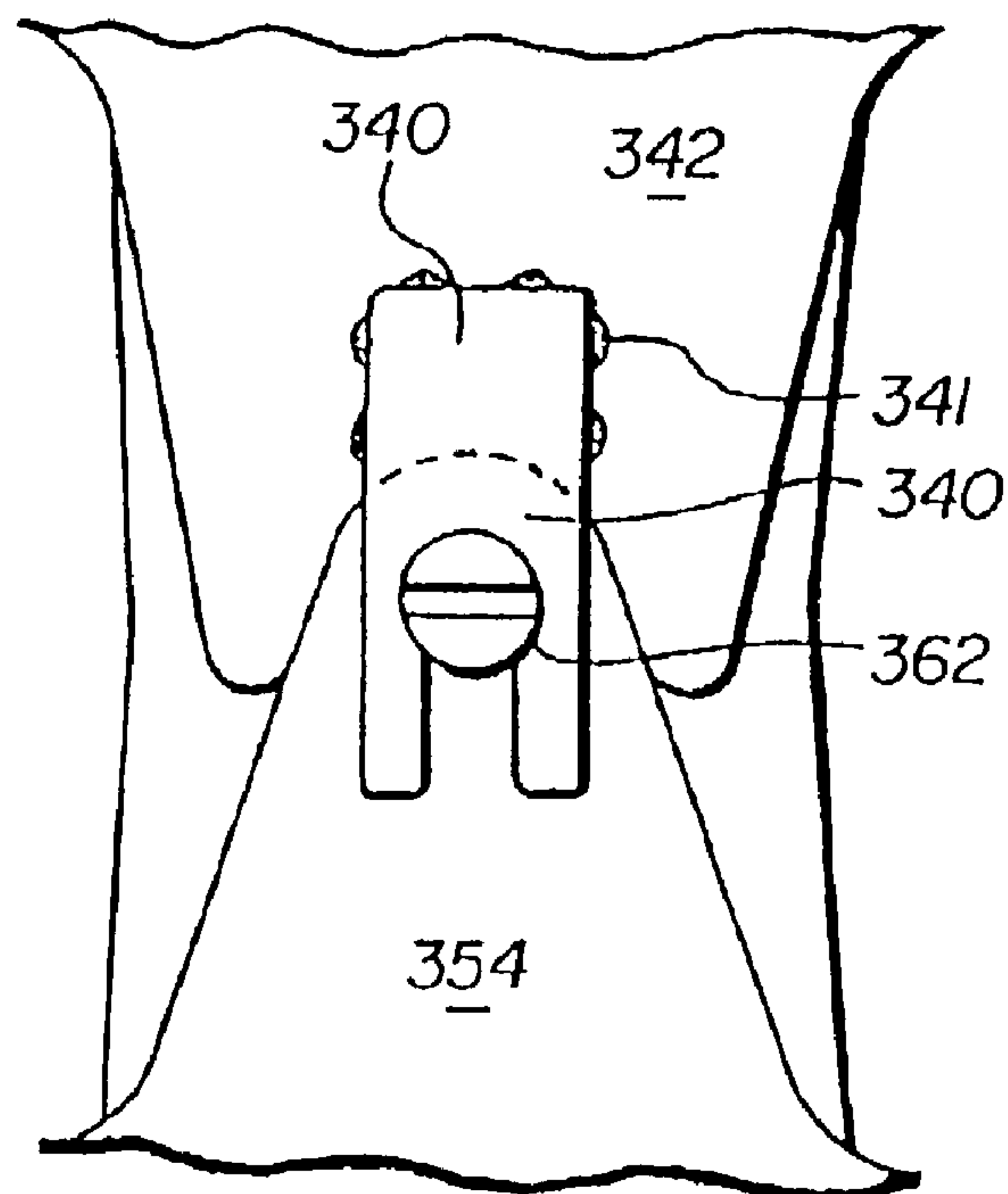

FIG. 9

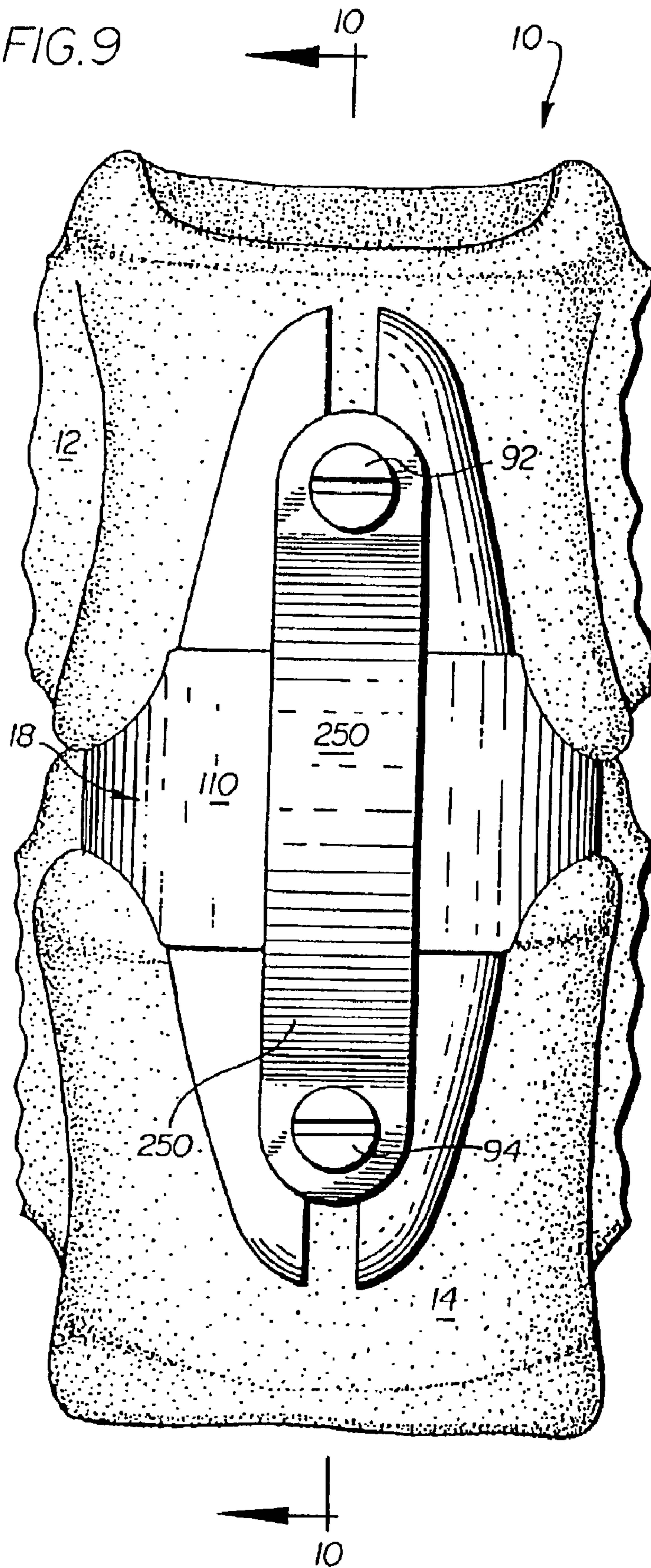



FIG. 10

10

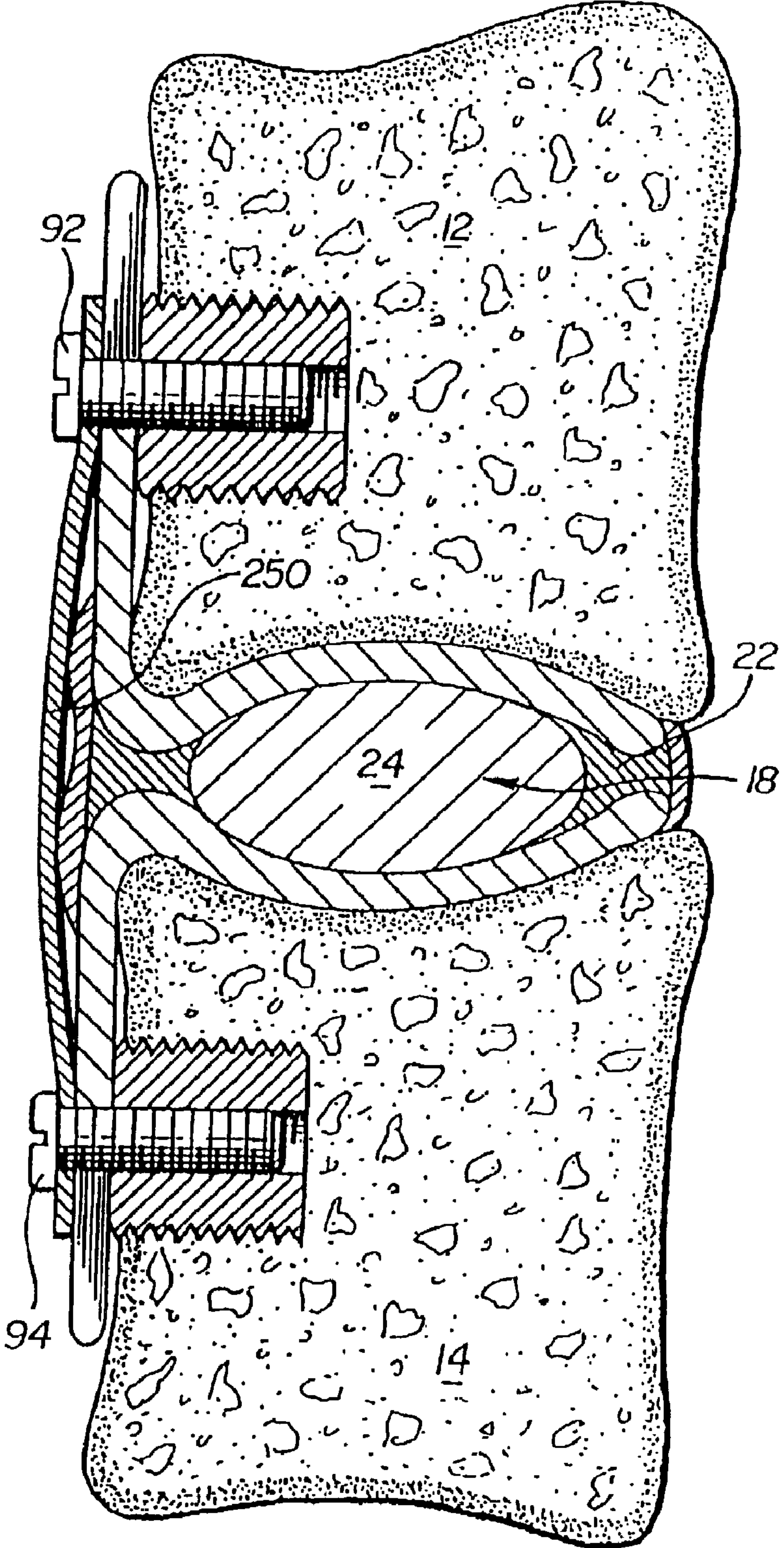

FIG. 11

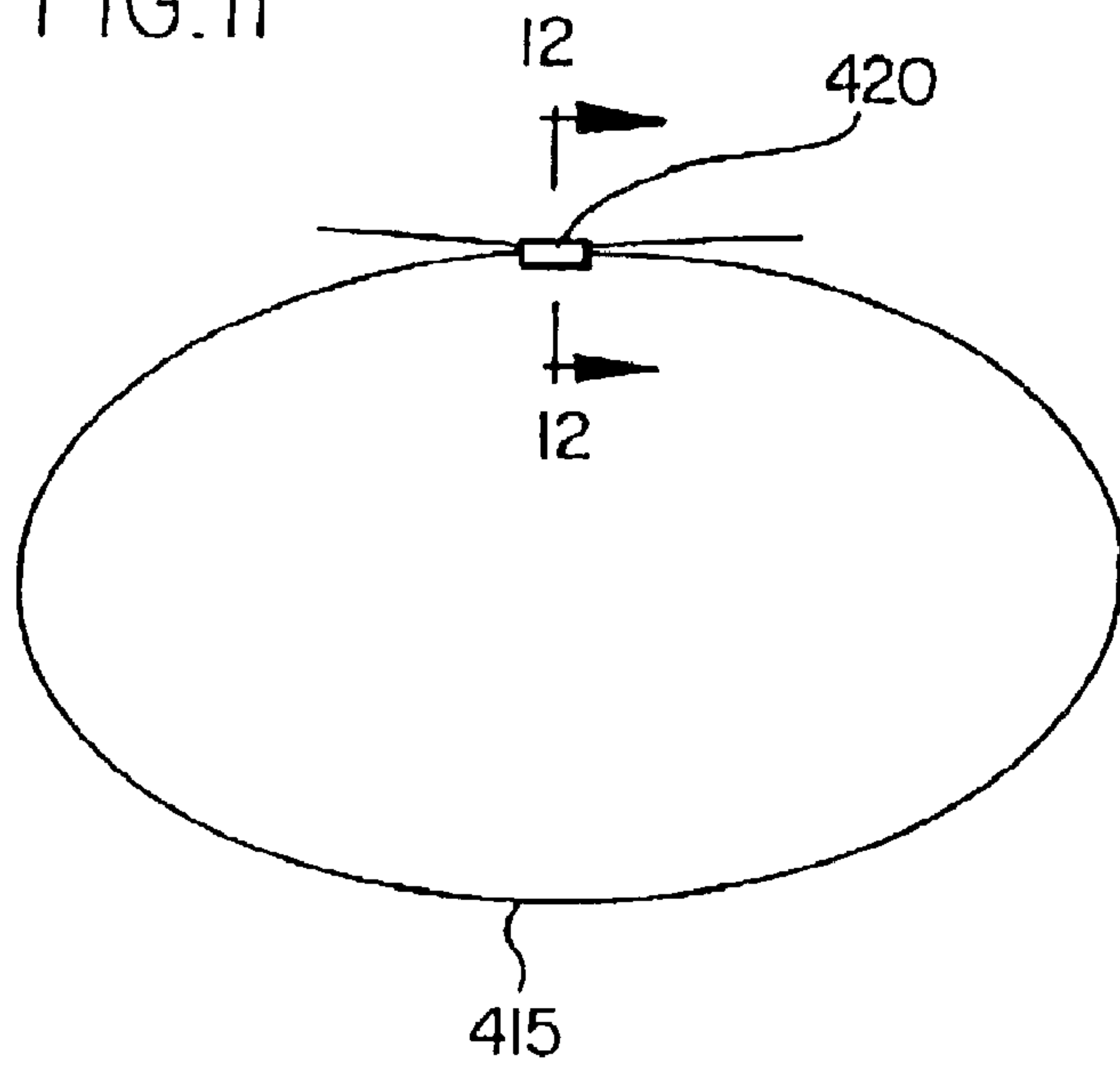

FIG. 12

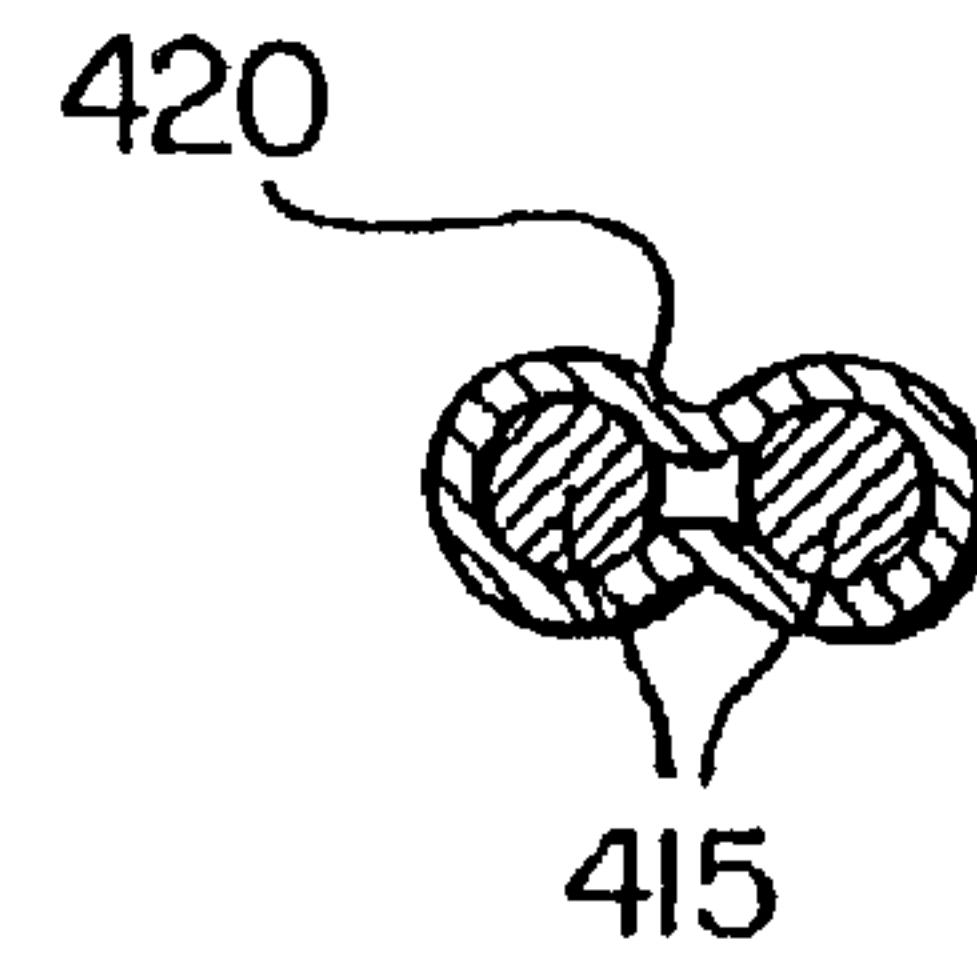

FIG. 13

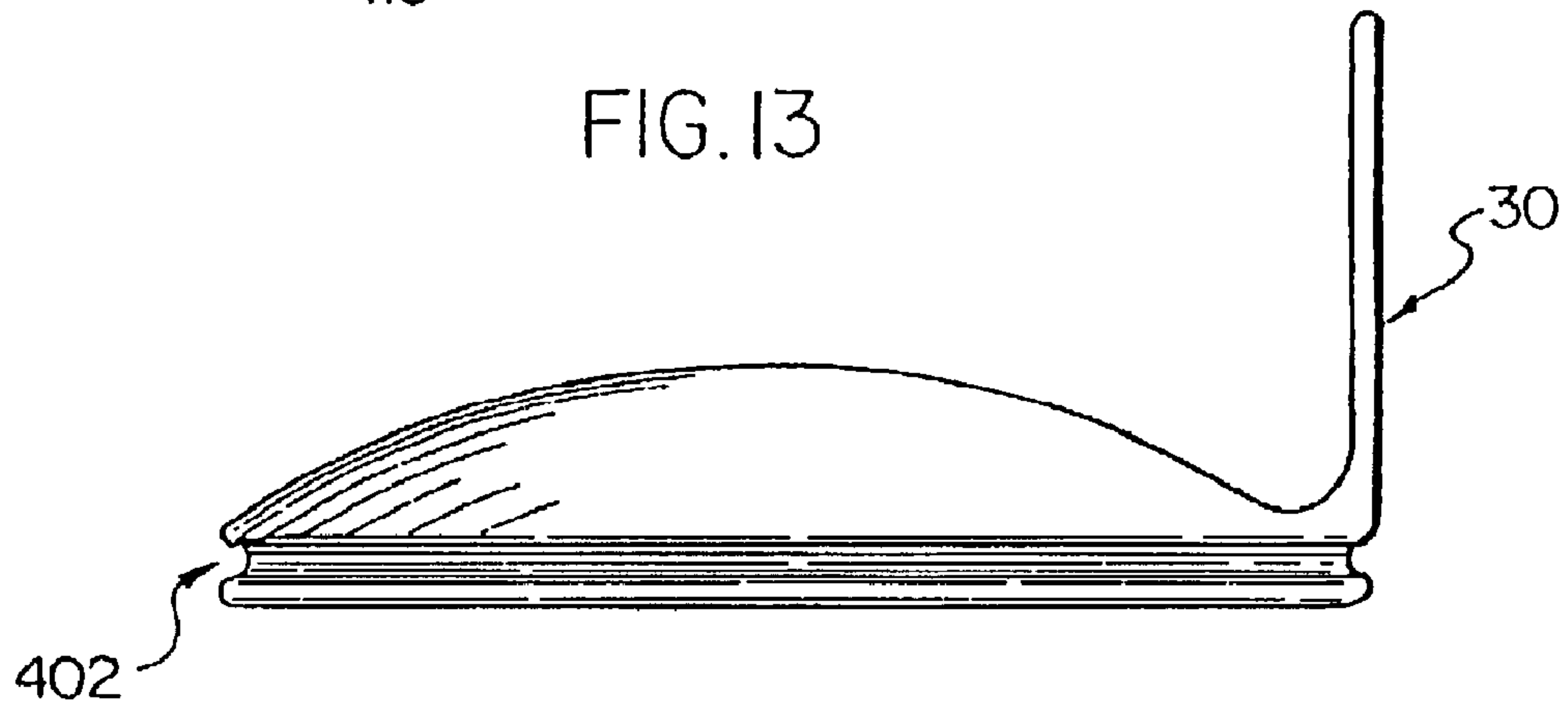
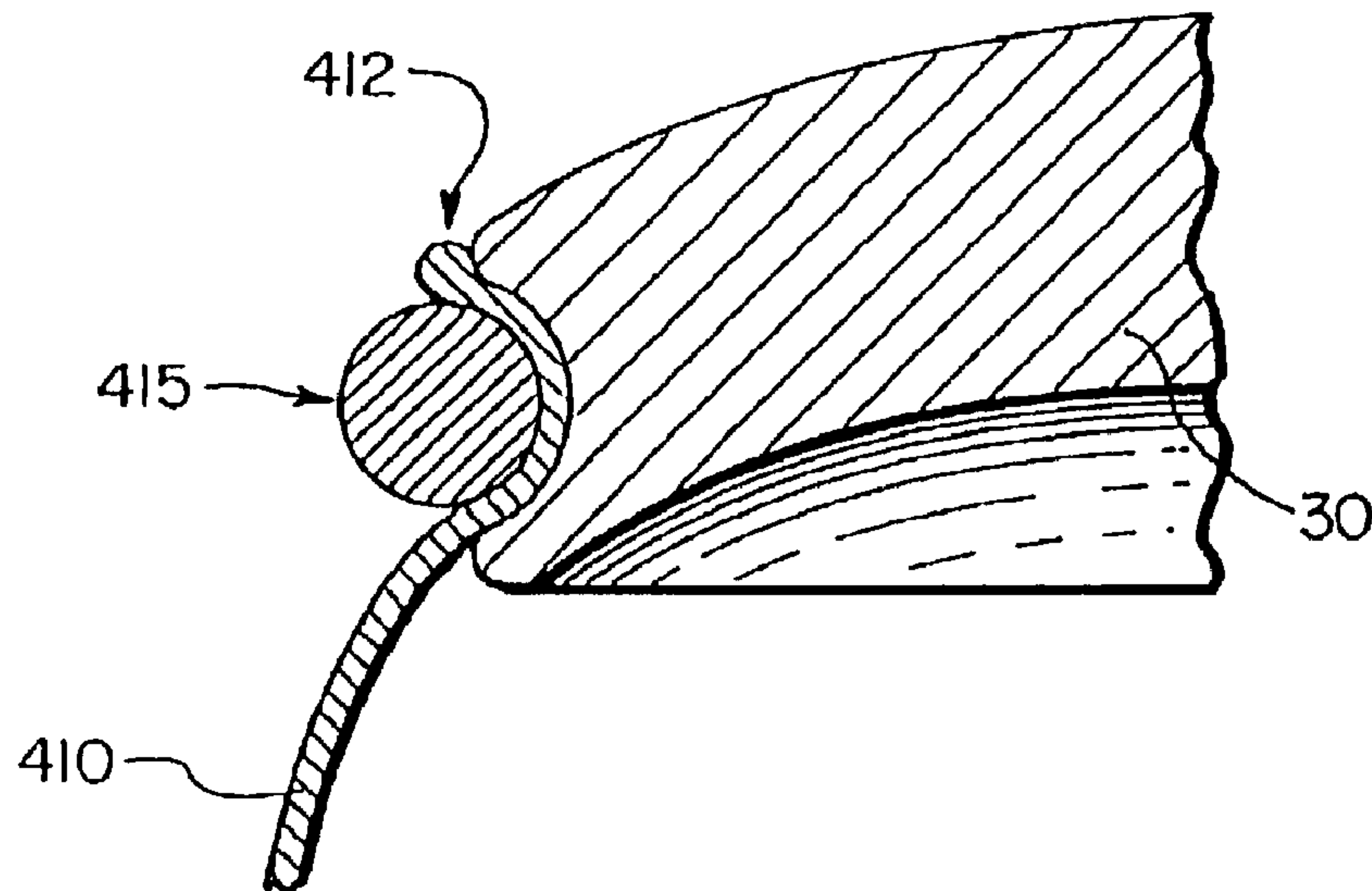

FIG. 14





## HUMAN SPINAL DISC PROTHESIS WITH HINGES

**Matter enclosed in heavy brackets [ ] appears in the original patent but forms no part of this reissue specification; matter printed in italics indicates the additions made by reissue.**

This is a continuation-in-part of U.S. patent application Ser. No. 08/681,230, filed Jul. 22, 1996, now U.S. Pat. No. 5,674,296 and which is a continuation-in-part of U.S. patent application Ser. No. 08/339,490, filed Nov. 14, 1994, which is abandoned.

### BACKGROUND OF THE INVENTION

This invention relates generally to human prostheses, and especially to spinal column [vertebral] *intervertebral* disc prostheses. The invention also relates to surgical procedures for preparing the patient to receive [a vertebral] *an intervertebral* disc endoprosthesis, and for implanting that endoprosthesis in the patient's spine.

The herniation of a spinal disc and the often resultant symptoms of intractable pain, weakness, sensory loss, incontinence and progressive arthritis are among the most common of debilitating processes affecting mankind. If a patient's condition does not improve after conservative treatment, and if clear physical evidence of nerve root or spinal cord compression is apparent, and if correlating radiographic studies (i.e., MRI or CT imaging or myelography) confirm the condition, surgical removal of the herniated disc may be indicated. The process of discectomy—as the name implies— involves the simple removal of the disc without attempt to replace or repair the malfunctioning unit. In the United States in 1985, over 250,000 such operations were performed in the lumbar spine and in the cervical spine.

Statistics suggest that present surgical techniques are likely to result in short-term relief, but will not prevent the progressive deterioration of the patient's condition in the long run. Through better pre-operative procedures and diagnostic studies, long-term patient results have improved somewhat. But it has become clear that unless the removed disc is replaced or the spine is otherwise properly supported, further degeneration of the patient's condition will almost certainly occur.

In the mid-1950's and 60's, Cloward and Smith & Robinson popularized anterior surgical approaches to the cervical spine for the treatment of cervical degenerative disc disease and related disorders of the vertebrae, spinal cord and nerve root; these surgeries involved disc removal followed by interbody fusion with a bone graft. It was noted by Robinson (Robinson, R. A.: *The Results of Anterior Interbody Fusion of the Cervical Spine*, J. Bone Joint Surg., 440A: 1569-1586, 1962) that after surgical fusion, osteophyte (bone spur) reabsorption at the fused segment might take place. However, it has become increasingly apparent that unfused vertebral segments at the levels above and below the fused segment degenerate at accelerated rates as a direct result of this fusion. This has led some surgeons to perform discectomy alone, without fusion, by a posterior approach in the neck of some patients. However, as has occurred in surgeries involving the lower back where discectomy without fusion is more common as the initial treatment for disc herniation syndromes, progressive degeneration at the level of disc excision is the rule rather than the exception. Premature degenerative disc disease at the level above and below the excised disc can and does occur.

Spine surgery occasionally involves fusion of the spine segments. In addition to the problems created by disc herniation, traumatic, malignant, infectious and degenerative syndromes of the spine can be treated by fusion. Other procedures can include bone grafts and heavy duty metallic rods, hooks, plates and screws being appended to the patient's anatomy; often they are rigidly and internally fixed. None provide for a patient's return to near-normal functioning. Though these procedures may solve a short-term problem, they can cause other, longer term, problems.

A number of attempts have been made to solve some of the problems described above by providing a patient with spinal disc prostheses, or artificial discs of one sort or another. For example, Steffee, U.S. Pat. No. 5,031,437, describes a spinal disc prosthesis having upper and lower rigid flat plates and a flat elastomeric core sandwiched between the plates. Frey et al., U.S. Pat. Nos. 4,917,704 and 4,955,908, disclose intervertebral prostheses, but the prostheses are described as solid bodies.

U.S. Pat. Nos. 4,911,718 and 5,171,281 disclose resilient disc spacers, but no inter-connective or containing planes or like elements are suggested, and sealing the entire unit is not taught.

It is the primary aim of the present invention to provide [a vertebral] *an intervertebral* disc endoprosthesis which will perform effectively and efficiently within a patient's spine over a long period of time, and which will not encourage degeneration of or cause damage to adjacent natural disc parts.

It is a related objective to provide a new [vertebral] *intervertebral* disc endoprosthesis surgical procedure which will decrease post-operative recovery time and inhibit post-operative disc, vertebral body and spinal joint degeneration.

It is yet another object to provide a method of installing the endoprosthesis so as to accurately mate the endoprosthesis with an adjacent specifically formed bone surface. An associated object is to provide an endoprosthesis which will encourage bone attachment to, and growth upon, adjacent outer surfaces of the endoprosthesis.

Yet another object is to provide a vertebral endoprosthesis in which the parts are non-oncogenic.

Still another object is to provide [a vertebral] *an intervertebral* disc endoprosthesis having a resilient element to accommodate shocks and other forces applied to the spine.

Another object is to provide a highly effective vertebral endoprosthesis which includes several disc endoprostheses and one or more prosthetic vertebral bodies. A related object is to provide these elements in a pre-assembled array for implantation in a patient.

### SUMMARY OF THE INVENTION

To accomplish these objects, the invention comprises a resilient body formed of a material varying in stiffness from a relatively stiff exterior portion to a relatively supple central portion. A concave-convex means at least partly surrounds that resilient body so as to retain the resilient body between adjacent vertebral bodies of a patient's spine. If medical considerations so indicate, several disc endoprostheses can be combined with one or more endoprosthetic vertebral bodies in an entire assembly.

To implant this endoprosthesis assembly, information is obtained regarding the size, shape, and nature of a patient's damaged natural spinal discs. If one or more of the patient's vertebral bodies also require replacement, information about those bodies is also obtained. Thereafter, one or more prosthetic disc units and interposed prosthetic vertebral body



3

units are constructed and preassembled in conformity with that information. Finally, the completed and conformed prosthetic disc and vertebral body assembly is implanted in the patient's spine.

Other objects and advantages of the invention will become apparent upon reading the following detailed description and upon reference to the drawings. Throughout the drawings, like reference numerals refer to like parts.

#### BRIEF DESCRIPTION OF THE DRAWINGS

FIG. 1 is a fragmentary vertical view of a portion of a human spine in which is installed a novel vertebral disc endoprosthesis embodying the present invention;

FIG. 2 is a fragmentary side elevational view similar to FIG. 1 showing the elements of a patient's spine and having a novel vertebral disc endoprosthesis embodying the present invention installed therein;

FIG. 3 is a sectional view taken substantially in the plane of line 3-3 in FIG. 1;

FIG. 4 is an exploded view of the novel vertebral disc endoprosthesis;

FIG. 5 is a vertical fragmentary view of a patient's spine similar to FIG. 1, but showing a series of novel disc endoprosthesis units installed in the spine and interconnected to one another;

FIG. 6 is a fragmentary sectional view of a patient's spine similar to FIG. 3 and taken along line 6-6 in FIG. 5, but showing a natural upper vertebral body, and upper endoprosthetic disc; an adjacent endoprosthetic vertebral body; a second or lower endoprosthetic disc; and a second or lower natural vertebral body;

FIG. 7 is a sectional view taken substantially in the plane of line 7-7 of FIG. 6;

FIG. 8 is a fragmentary side elevational view of the assembly shown in FIG. 6; and

FIG. 9 is a fragment vertical view, similar to FIG. 1, of a portion of a human spine in which is installed a variant form of the novel vertebral disc endoprosthesis the variant form having a prosthetic longitudinal ligament;

FIG. 10 is a sectional view taken substantially in the plane of line 10-10 in FIG. 9;

FIG. 11 is a top view of a retainer means for use with a vertebral disc endoprosthesis;

FIG. 12 is a sectional view taken substantially in the plane of line 12-12 of FIG. 11;

FIG. 13 is a side view of a vertebral disc endoprosthesis having a groove for receiving the retainer means; and

FIG. 14 is a cross-sectional view of the retainer means in use.

#### DETAILED DESCRIPTION

While the invention will be described in connection with a preferred embodiment and procedure, it will be understood that it is not intended to limit the invention to this embodiment or procedure. On the contrary, it is intended to cover all alternatives, modifications, and equivalents as may be included within the spirit and scope of the invention as defined by the appended claims.

Turning more specifically to FIGS. 1-3, a portion of a human spine 10 is shown. The illustrated spine 10 has been subjected to a discectomy surgical process. To discourage degeneration of or damage to the natural vertebral bodies 12 and 14 and their respective facet joints, in accordance with the invention, [a vertebral] *an intervertebral* disc endoprosthesis 18 is affixed between the adjacent natural vertebral bodies 12

4

and 14. Here this [vertebral] *intervertebral* disc endoprosthesis 18 comprises a resilient disc body 20 having a relatively stiff annular gasket exterior portion 22 and a relatively supple nuclear central portion 24. The annular gasket 22 can be formed from a suitable biocompatible elastomer in the range of approximately 70-90 durometer hardness and the nuclear central portion 24 can be formed from a softer biocompatible elastomeric polymer of approximately 30 durometer hardness. In an alternate embodiment, the gasket 22 can extend over and under the nuclear central portion 24 so as to fully enclose it within a thin layer. In a further embodiment, the nuclear central portion, the gasket, and the thin layer extension are molded together to form one piece having different durometer hardnesses.

Concaval-convex means 30 surround the resilient body 20 to retain the resilient body 20 between the adjacent natural vertebral bodies 12, 14 in a patient's spine 10. To this end, as shown in FIG. 3, the concaval-convex means 30 comprise two generally L-shaped supports 32 and 34. The supports 32, 34 each have confronting first concaval-convex legs 42, 44, each leg being of relatively constant cross-sectional thickness. Each leg 42, 44 has an outer convex surface 52, 54 for engaging the adjacent bone of the natural vertebral bodies 12, 14. Corresponding inner concave surfaces 62, 64 in confronting array retain the resilient body 20 in its illustrated compressive force shock-absorbing position. These supports 32 and 34 can undergo principle movement away from one another, but only limited secondary translational, rotational and distractive motion will occur. Each support 32, 34 has a second wing or leg 72, 74 extending generally perpendicularly to the first legs 42, 44 respectively, and adapted for affixation to the adjacent bone structure. To carry out aspects of the invention described below, this affixation is effectively accomplished by cannulated screw devices 82, 84 which may be of a biodegradable type manufactured by Zimmer of Largo, Fla. Each device 82, 84 comprises a screw 92, 94; and a screw anchor 102, 104 adapted to threadably receive the screw extends radially into and seats within the bone structure 12, 14 as especially shown in FIG. 3. The screws 92, 94 may terminate in the anchor or alternately proceed through an open ended anchor and terminate in the bone of the vertebral body 12, 14 directly. The anchors 102, 104 may be close-ended, open ended, or of the expansion type.

To discourage and prohibit migration of fluids between the endoprosthesis 18 and adjacent parts of the anatomy, a seal member 110 is attached to the supports 32, 34 so as to surround the resilient body 20 which is comprised of the gasket 22 and nucleus 24, in accordance with another aspect of the invention. Here, this seal member 110 comprises a flexible sheet material having a multiplicity of pores. Preferably, the pores are from about 5 microns to about 60 microns in size. A flexible, strong polymer sheet material from which this seal is formed can be a Kevlar-like material, or it can be Goretex-like material, expanded PTFE, or other appropriate biocompatible material, such as polyether, polyurethane, or polycarbonate urethane membranes, can be used. Kevlar material is offered by the E. I. DuPont de Nemours Company of Wilmington, Del. and Goretex material is offered by the W. T. Gore Company of Flagstaff and Phoenix, Ariz. The seal material may be lined on its interior surface, its exterior surface, or both surfaces with silicone or any suitable sealing material so as to render the flexible sheet material substantially impervious to the passage of any fluid. A watertight seal is perfected when the seal 110 is glued or otherwise affixed to the legs 42, 44 and mediate portions of the legs 72, 74 as suggested in FIGS. 1-3.

In the space beneath the seal member 110 and between the disc body 20 and the concave surfaces of legs 42, 44, a



lubricant may be used. The lubricant used may be saline or an appropriate liquid or particulate material lubricant.

In an alternative embodiment, the watertight seal between the endoprosthesis **18** and adjacent parts of the anatomy can be provided by developing a groove **402** completely encircling the periphery of each of the legs **42, 44**. In this embodiment, the legs **72, 74** may be attached to the circumferential groove member **402** by laser-welding or other suitable means. If the legs **72, 74** are of polymeric material, they may be attached by mechanical or adhesive techniques. Only one of the grooves is shown in FIG. **13**. In this embodiment, the seal member **410** is provided with a beaded edge **412** for each groove. Additionally, a retaining band **415** is provided for each groove to retain the seal member **410** in groove **402**. The retaining bands **415** can be in the form of a biocompatible monofilament wire of, for example, stainless steel or titanium, a synthetic polymer cable or a braided wire cable. As shown in FIG. **11**, each retaining band is crimped anteriorly by a crimping sleeve **420**. Of course, more than one crimping sleeve may be used, if necessary. Alternately, the retaining band is fastened by laser-welding. Although one sealing arrangement consisting of the groove, beaded edge and retaining band is shown in FIG. **14**, it should be understood that the sealing arrangement on the concaval-convex leg of the other support is identical in design and function.

In use, the seal member **410** is placed about the concaval-convex means **30**. The retaining bands **415** are then placed adjacent to the respective groove **402** and crimped anteriorly, thereby fitting the bands into the grooves. Each beaded edge **412** prevents the slipping of the seal member underneath the retaining band. Thus, the retaining band, the groove and the beaded edge all cooperate to provide a water-tight seal to prevent the migration of fluids between the endoprosthesis **18** and adjacent parts of the anatomy. Glue can also be used to affix the seal member to the concaval-convex means **30** as a supplemental means for perfecting the seal.

In a first embodiment, the first legs **42, 44** are formed as an integral piece with the respective second wings or legs **72, 74**. In the alternate embodiment of FIG. **3**, however, the first legs **42, 44** are hingedly attached to the respective second legs **72, 74**. A hinge **43, 73** is provided at the point from which the second leg **72, 74** extends generally perpendicularly to the first leg **42, 44**. The hinge is not intended to function as such after being installed, but only during installation so as to allow better alignment of the endoprosthesis with the biologically variable anterior surface of the respective vertebral body. Once the endoprosthesis is installed and affixed via the screw devices, the hinge will no longer move.

These hinges **43, 73** may take any of the several known forms. Each hinge can be a rod and socket hinge, a pin type hinge, or a slip joint fitting, or it can be a web or a membrane type hinge of metal or plastic.

The second wings or legs **72, 74** may be made of a suitable metal such as titanium or a polymeric material. Alternately, each leg **72, 74** including its associated hinge element, can be made of a biodegradable polymeric material. When the legs **72, 74** are made of biodegradable material, the screws **92, 94** used for affixing the legs to the adjacent bone structure may be of the standard shoulder screw type in order to maintain firm fixation to the screw anchors **102, 104** after biodegradation of the legs **72, 74**.

Legs **72, 74** can be of a thin construction that allows some degree of flexibility so as to promote a better mating of the legs to the anterior aspect of the vertebral body **12, 14**.

The legs can have a central closed oblong slot to accommodate a screw or other fixation device. Should a second endoprosthesis device be placed at an adjoining level, the leg

**72, 74** would be placed on top of the corresponding leg from the adjacent device. The screw **92, 94** or other fixation device would then pass through the closed oblong slot of the overlapping legs **72, 74**.

In accordance with another aspect of the invention, the supports **32, 34** are formed of a biocompatible metal which may contain chromium cobalt or titanium. Surface roughening or titanium beading **112, 114** on the exterior surfaces **52, 54** of legs **42, 44** encourages positive bonding between the adjacent bone and the convex surfaces **52, 54**. Over time, bone fuses or grows into the surface roughening, thereby adhering to the legs **42, 44** in a rigid and strong manner.

As suggested in FIGS. **9** and **10**, a prosthetic longitudinal ligament **250** can be connected between the screws **92, 94** to limit motions between elements of the spine **10** in the area where the endoprosthesis **18** is implanted. This strap **250** may be made of the Kevlar-like material or the Goretex-like material described above, or it may be made of any other strong biocompatible material. The ligament **250** may also be considered a spacer or cover for providing some degree of separation between overlying soft tissues in the body and the anterior-most surfaces of the device. However, it is not designed for restricting or preventing motion in the disc body. A biodegradable washer can be provided around the screws **92, 94** at a point between the strap **250** and the respective wing or leg **72, 74**. When biodegradable washers are used, the screws **92, 94** used for affixing the legs to the adjacent bone structure may be of the standard shoulder screw type in order to maintain firm fixation to the screw anchors **102, 104** after biodegradation of the washers.

When a ligament is used in the embodiment of the device having hinged legs **92, 94**, the prosthetic longitudinal ligament structure can comprise several parallel bands of material separated by approximately 10 mm.

In accordance with another aspect of the invention, multiple endoprosthetic disc units can be placed in series with a straddling interlock appendage providing stability and fixation as shown in FIG. **5**. Entire portions of a patient's spine can be replaced by a series of interconnected endoprosthetic vertebral bodies and endoprosthetic disc units. FIGS. **6-8** show an upper natural vertebral body unit **312** to which an upper endoprosthetic body **308** has been attached. A lower natural vertebral body **314** has attached, at its upper end, an endoprosthetic disc unit **318**. Between these endoprosthetic disc units **308** and **318** is an endoprosthetic vertebral body **320**. As suggested by FIG. **7**, the endoprosthetic vertebral body **320** need not be irregularly shaped in cross sectional aspect; rather, manufacturing processes may suggest that it have a circular cross-sectional shape. As shown in FIGS. **6** and **8**, this endoprosthetic vertebral body **320** comprises a titanium element **321**, to which are attached the preformed upper and lower endoprosthetic vertebral body upper and lower concaval-convex elements **322, 324**. Each concaval-convex element **322, 324** is attached to the prosthetic vertebral body **320**, as shown in FIG. **7**, by extending set screws **330** through the titanium vertebral body **321** into a stem-like projection **331** extending from each of the concaval-convex elements **322, 324**. A hole **360** in the body **320** accommodates the stem-like projections **331** of the concaval-convex elements **322** and **324**. The stem-like projection **331** of the concaval-convex elements **322** and **324** is used only in conjunction with a prosthetic vertebral body implant construction **320**.

An ear **340** is affixed, as by weldments **341**, to a leg **342** extending from a concaval-convex element **322** as illustrated in FIGS. **6** and **8**. An anchor **352** can be threaded into the endoprosthetic vertebral body **320**, and a screw **362** can be



turned into the anchor 352 so as to rigidly assemble the leg 342 to a leg 354 extending from the lower endoprosthesis disc unit 318.

In an alternate embodiment, ear 340 could be replaced with a biodegradable washer around each of the screws 92, 94 at a point located between the strap 250 and the respective leg 72, 74. (FIG. 10.) The washer could be of a size to overlie and fix in place the interlocking wing leg from the adjacent intervertebral disc space. Alternately, ear 340 (FIG. 8.) may be eliminated in favor of screws 92, 94 having a head of increased diameter so that the screw head engages and fixes both the slotted leg 72, 74 and the interlocking tongue leg.

The upper disc endoprosthesis 308, the endoprosthesis vertebral body 320, and the lower disc endoprosthesis 318 can all be assembled and interconnected as a unit before implantation in a patient's body when indicated.

As also suggested in FIG. 6, the annular corners 372, 374 of natural vertebral bodies 312, 314 each can extend irregularly radially outwardly of the adjacent disc endoprosthesis 308, 318. However, the corners 382B, 384B of the prosthetic vertebral body 320 do not generally extend significantly outside those disc units 308, 318, thus discouraging vertebral body engagement with and consequent abrasion or other damage to adjacent portions of the patient's natural anatomy. Preferably the endoprosthesis vertebral body 320 is not exactly right cylindrical in shape, but is rather slightly biconical; that is, the endoprosthesis vertebral body 320 has a waist 390 of minimum radius R at an axial medial point as suggested in FIG. 6.

According to yet another aspect of the invention, novel surgical procedures permit effective and permanent installation of the endoprosthesis vertebral body 320 and associated parts. First, a surgeon or medical technician develops information about the size, shape and nature of a patient's damaged vertebral body or bodies from radiographs, CT and/or MRI scans, noting specifically the anterior-posterior and lateral dimensions of the end plate of each involved vertebral body and the vertical height of the anterior aspect of each involved vertebral and/or proximate vertebral body and vertical height of the mid portion of involved and proximate relatively normal intervertebral disc spaces. This information is transmitted by telephone, computer datalink or documentary transport to a specialized laboratory. That laboratory constructs one or more prosthetic assemblies of the sort shown in FIG. 6 in conformity with the received information and this disclosure. Each of the assemblies can include a prosthetic vertebral body 321, and at each body end is a prosthetic disc 308, 318. Each prosthetic disc unit comprises, in turn, the concaval-convex elements 30; the resilient body 20 interposed between the concaval-convex elements; and the seal unit 110 secured around the interior legs and resilient body. Thereafter, the completed and conformed assembly is implanted in the patient's spine 10.

When the unit or units have been received and the patient properly prepared, the damaged natural spinal disc or discs and vertebral body or bodies are removed and the adjacent spinal bone surfaces are milled or otherwise formed to provide concave surfaces to receive the confronting convex surfaces 52, 54. Thereafter, the disc units and vertebral body are installed in the patient's spine.

To accurately locate the concaval-convex surfaces in the patient's spine, holes 382A, 384A (FIG. 3) are precisely located and then formed in the bone structure using a measuring instrument centered in the evacuated natural [intravertebral] intervertebral disc space. These holes are then tapped to form female threads therein. When the threads have been formed, the anchors 102, 104 are implanted in the respective tapped holes, thereby creating an imaginary platform of ref-

erence points located precisely with respect to the patient's spine. After the holes have been formed and the anchors 102, 104 implanted, a bone surface milling jig (not shown) is affixed to the anchors 102, 104 and the desired concave surfaces of predetermined shape are formed on the inferior and superior surfaces of the opposing vertebral bodies using one of a selection of predetermined milling head or bit sizes. Thereafter, the bone milling jig is removed and the concaval-convex elements 52, 54 identical in shape to the milled surfaces 112, 114 are inserted between the distracted milled vertebral bodies 12, 14. The distraction device is then moved. The concaval-convex structures are then attached by the same anchors 102, 104 to the bone, thus insuring a precise and stable mate between the bone surfaces and the convex surfaces 52, 54.

If necessary, a damaged implanted nucleus and/or gasket 24 can be removed and replaced. This can be accomplished by slitting the seal 110; removing the annular gasket 24 and damaged nucleus 22, and replacing them with new, undamaged elements. Thereafter, the seal 110 can be re-established by suturing or gluing closed the slit seal.

We claim:

1. [A vertebral] *An intervertebral* disc endoprosthesis, comprising a resilient body formed of materials varying in stiffness from a relatively stiff exterior portion to a relatively supple central portion; and concaval-convex elements at least partly surrounding the resilient body for retaining said resilient body in a position between the concaval-convex elements, and wherein said concaval-convex elements each comprise generally L-shaped supports, each support having a first concaval-convex leg, the first leg having an outer convex surface for engaging adjacent bone and a corresponding inner concave surface for retaining the resilient body, each support further having a second leg extending generally perpendicularly to the first leg [and adapted for affixation to adjacent bone structures].

2. [A vertebral] *An intervertebral* disc endoprosthesis according to claim 1 wherein said resilient body comprises an annular gasket and a nuclear central portion.

3. [A vertebral] *An intervertebral* disc endoprosthesis according to claim 2 wherein the gasket extends about the nuclear central portion [to enclose it within a thin layer].

4. [A vertebral] *An intervertebral* disc endoprosthesis according to claim 3 wherein the gasket[,] and the nuclear central portion[, and the thin layer] are molded together as one piece.

5. [A vertebral] *An intervertebral* disc endoprosthesis according to claim 1 further comprising cannulated screw means for attaching the concaval-convex element supports to adjacent bone structure.

6. [A vertebral] *An intervertebral* disc endoprosthesis according to claim 5 wherein said cannulated screw means comprises a screw, and a screw anchor seatable within bone structure and adapted to threadably receive the screw.

7. [A vertebral] *An intervertebral* disc endoprosthesis according to claim 6 wherein the screws terminate in the anchor.

8. [A vertebral] *An intervertebral* disc endoprosthesis according to claim 6 wherein the anchor has an open end and the screw proceeds through the open end of the anchor and terminates in the bone of the vertebral body.

9. [A vertebral] *An intervertebral* disc endoprosthesis according to claim 1 further comprising a seal member attached to the concaval-convex elements and surrounding said resilient body.

10. [A vertebral] *An intervertebral* disc endoprosthesis according to claim 9 wherein said seal member comprises a



flexible sheet material having a multiplicity of pores, the pores being from about 5 microns to about 60 microns in size.

11. [A vertebral] *An intervertebral disc endoprosthesis according to claim 10 further including sealing means applied to said flexible sheet material to render said flexible sheet material substantially impervious to the passage of any fluid.*

12. [A vertebral] *An intervertebral disc endoprosthesis according to claim 11 wherein the sealing means is silicone.*

13. [A vertebral] *An intervertebral disc endoprosthesis according to claim 9 wherein said concaval-convex elements and said seal member collectively surround said resilient body with a watertight seal.*

14. [A vertebral] *An intervertebral disc endoprosthesis according to claim 2 wherein said annular gasket is relatively stiff and said nuclear central portion is relatively supple.*

15. [A vertebral] *An intervertebral disc endoprosthesis according to claim 1 wherein at least one of the second legs is hingedly attached to the respective first concaval-convex leg.*

16. [A vertebral] *An intervertebral disc endoprosthesis, comprising a resilient body formed of materials varying in stiffness from a relatively stiff exterior portion to a relatively supple central portion; and concaval-convex elements at least partly surrounding the resilient body between adjacent vertebral bodies for retaining the resilient body between adjacent vertebral bodies in a patient's spine, and wherein said concaval-convex elements each comprise generally L-shaped supports, each support having a first concaval-convex leg, the first leg having an outer convex surface for engaging adjacent bone and a corresponding inner concave surface for retaining the resilient body, each support further having a second leg extending generally perpendicularly to the first leg and adapted for affixation to adjacent bone structure, wherein at least the second leg is constructed of titanium.*

17. [A vertebral] *An intervertebral disc endoprosthesis comprising a resilient nucleus, first and second rigid concaval-convex elements at least partly surrounding the nucleus, first and second legs formed, respectively, with the*

first and second rigid concaval-convex elements, first and second means for affixing the respective legs to vertebral bodies adjacent the concaval-convex elements and nucleus, longitudinal ligament prosthesis means extending between the legs of the first and second concaval-convex elements to inhibit undesirable motion of the vertebral bodies relative to one another, and biodegradable washers positioned between the ligament prosthesis means and the respective legs.

18. [A vertebral] *An intervertebral disc endoprosthesis comprising a rounded, resilient nucleus body convex on all surfaces and concaval-convex elements, each concaval-convex element being of relatively constant cross-sectional thickness and having an outer convex surface for engaging adjacent bone structure which has been milled to mate with the concaval-convex element outer convex surface, and a corresponding inner concave surface for engaging the rounded resilient body, wherein lubricant is provided between the nucleus body and the concaval-convex elements.*

19. [A vertebral] *An intervertebral endoprosthesis comprising an integral disc unit, said unit including a pair of confronting L-shaped supports having concaval-convex shapes in given legs, a resilient body interposed between the supports, and a flexible seal extending from one support to the other and sealing the resilient body within the supports inside a substantially watertight compartment, further comprising a plurality of said integral disc units.*

20. The [vertebral] intervertebral disc endoprosthesis according to claim 19 wherein each support includes a groove about its circumference.

21. *The intervertebral disc endoprosthesis according to claim 13, wherein the seal member comprises a flexible sheet secured to each of the concaval-convex elements.*

22. *The intervertebral disc endoprosthesis according to claim 19, further comprising a plurality of said integral disc units.*

\* \* \* \* \*