

US00RE42449E

(19) **United States**
(12) **Reissued Patent**
Forster

(10) **Patent Number:** **US RE42,449 E**
(45) **Date of Reissued Patent:** **Jun. 14, 2011**

(54) **PIEZO-ELECTRIC TAG**

(56) **References Cited**

(75) Inventor: **Ian James Forster**, Chelmsford (GB)

U.S. PATENT DOCUMENTS

(73) Assignee: **Mineral Lassen LLC**, Las Vegas, NV
(US)

1,863,345 A 6/1932 Nicolson
4,476,459 A * 10/1984 Cooper et al. 340/572.4
4,870,700 A 9/1989 Ormanns
4,951,057 A 8/1990 Nagel

(Continued)

(21) Appl. No.: **11/804,715**

FOREIGN PATENT DOCUMENTS

(22) PCT Filed: **Jul. 31, 2000**
(Under 37 CFR 1.47)

CN 2296042 Y 10/1998

(Continued)

(86) PCT No.: **PCT/GB00/02944**

OTHER PUBLICATIONS

§ 371 (c)(1),
(2), (4) Date: **May 30, 2002**

Chinese Office Action dated May 8, 2009, from Application No. CN 200610101348.5, filed Jul. 31, 2000.

(Continued)

(87) PCT Pub. No.: **WO01/09640**

PCT Pub. Date: **Feb. 8, 2001**

Primary Examiner — John A Tweel, Jr.

(74) *Attorney, Agent, or Firm* — Christensen O'Connor Johnson Kindness PLLC

Related U.S. Patent Documents

Reissue of:

(64) Patent No.: **6,894,616**
Issued: **May 17, 2005**
Appl. No.: **10/048,108**
Filed: **May 30, 2002**

(57) **ABSTRACT**

A piezo-electric tag in the form of a card has a first dipole antenna, a first rectification circuit, a piezo-electric transformer, a second rectification circuit, and a transponder circuit. In operation, the antenna receives incoming radiation and generates a corresponding signal which propagates to the first circuit which demodulates and filters it to generate a signal which is applied to the transformer to excite it. The transformer increases the voltage amplitude of the signal by generating a relatively higher voltage amplitude signal which is used in the tag to generate a signal for supplying power to the transponder. The transformer provides voltage magnitude enhancement to generate potentials suitable for operating active electronic circuits incorporated into the tag. The tag can be personnel wearable and even adapted for permanent inclusion into biological systems.

(30) **Foreign Application Priority Data**

Jul. 29, 1999 (GB) 9917856

(51) **Int. Cl.**
G08B 13/14 (2006.01)

(52) **U.S. Cl.** **340/572.1; 330/171; 310/310**

(58) **Field of Classification Search** 340/572.1,
340/10.34; 330/79, 165–171, 188, 190, 195;
342/30; 235/491, 492; 310/310, 311, 313 R

See application file for complete search history.

93 Claims, 6 Drawing Sheets

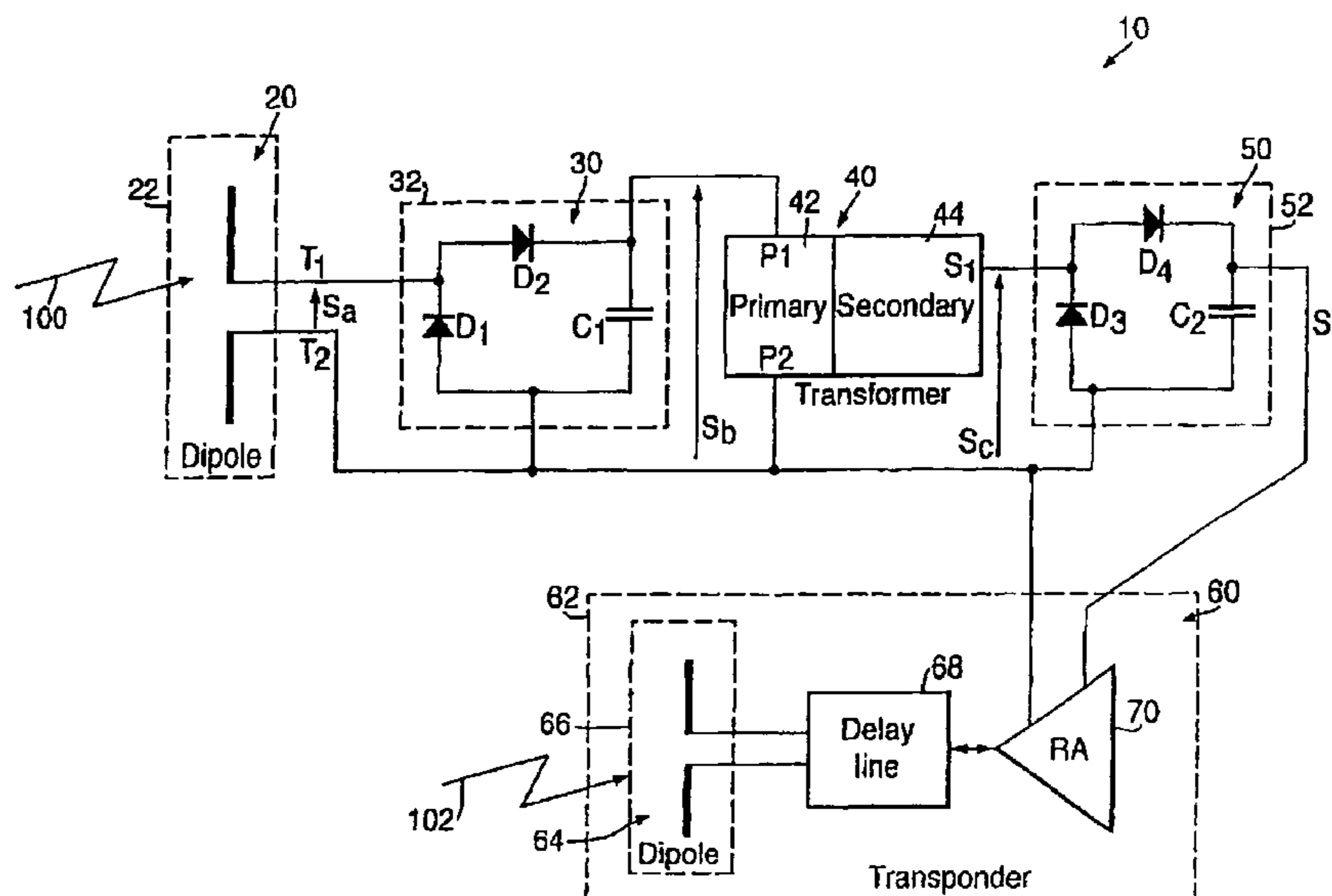

US RE42,449 E

Page 2

U.S. PATENT DOCUMENTS

5,132,665	A	7/1992	Hutchisson	
5,389,852	A	2/1995	Toda	
5,408,168	A	4/1995	Pfandler	
5,457,447	A	10/1995	Ghaem	
5,491,468	A	2/1996	Everett	
5,749,909	A	5/1998	Schroepfel	
5,828,160	A	10/1998	Sugishita	
5,866,969	A	2/1999	Shimada	
5,886,514	A	3/1999	Iguchi	
5,942,858	A	8/1999	Sokolov	
5,952,922	A *	9/1999	Shober	340/572.4
5,969,462	A	10/1999	Huang	
6,011,488	A *	1/2000	Busser	340/10.34
6,040,654	A *	3/2000	Le Letty	310/366
6,049,745	A *	4/2000	Douglas et al.	701/23
6,111,765	A	8/2000	Ganser	
6,121,892	A *	9/2000	Reindl et al.	340/571
6,639,872	B1	10/2003	Rein	
6,894,616	B1	5/2005	Forster	

FOREIGN PATENT DOCUMENTS

DE	19608515	C1	6/1997
DE	19755893	A1	6/1999
EP	0 827 105	A2	7/1997
EP	0827105	A2	3/1998
EP	0898313	A1	2/1999
EP	1206709	B1	5/2002
GB	2232027	A	11/1990
GB	2303767	A	2/1997
GB	2306081	A	4/1997
JP	61125179	A2	6/1986

JP	5135224	A	6/1993
JP	7198843	A	8/1995
JP	9074744	A	3/1997
JP	9090028	A	4/1997
JP	10065231	A	3/1998
JP	10127057	A	5/1998
JP	11145874	A	5/1999
WO	8800769	A1	1/1988
WO	97/44675	A1	11/1997
WO	9835276	A1	8/1998
WO	99/35276	A1	8/1998
WO	0109640	A1	2/2001

OTHER PUBLICATIONS

“Designing Detectors for RF/ID Tags,” Hewlett Packard Application Note 1089, 1997, pp. 1-12.

“Designing the Virtual Battery,” Hewlett Packard Application Note 1088, 1997, pp. 1-8.

“Surface Mount Microwave Schottky Detector Diodes,” Hewlett Packard Technical Data Bulletin, HSMS-2850/2860 Series, pp. 3-42-3-47.

International Search Report dated Dec. 4, 2000, issued in corresponding Application PCT/GB00/02944, filed Jul. 31, 2000.

Japanese Office Action mailed Jan. 7, 2010, issued in corresponding Japanese Patent Application No. 2001-514598, filed Jul. 31, 2000, 3 pages.

Japanese Office Action mailed Apr. 22, 2010, issued in corresponding Japanese Patent Application No. 2001-514598, filed Jul. 31, 2000, 2 pages.

* cited by examiner

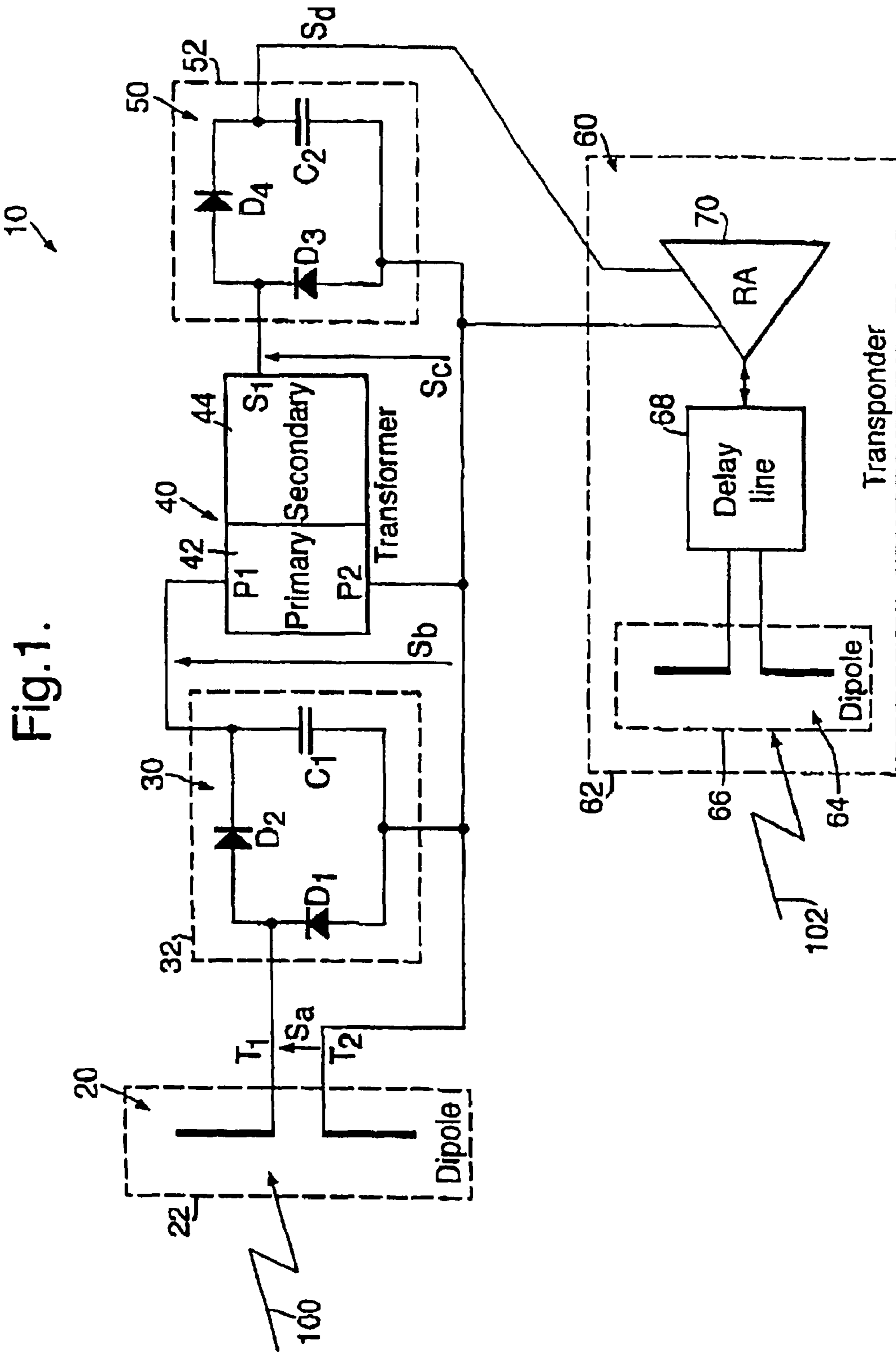
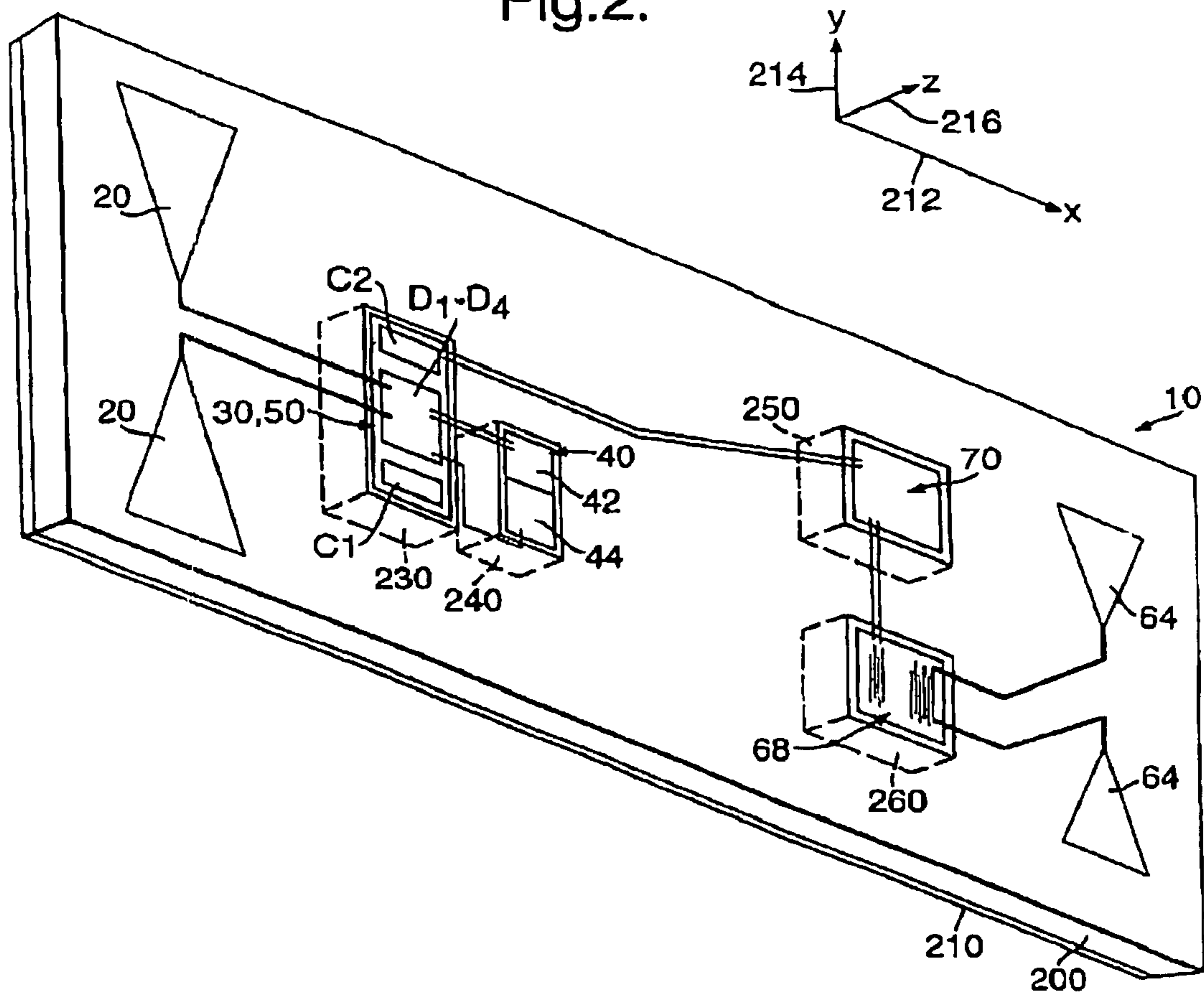

Fig.2.



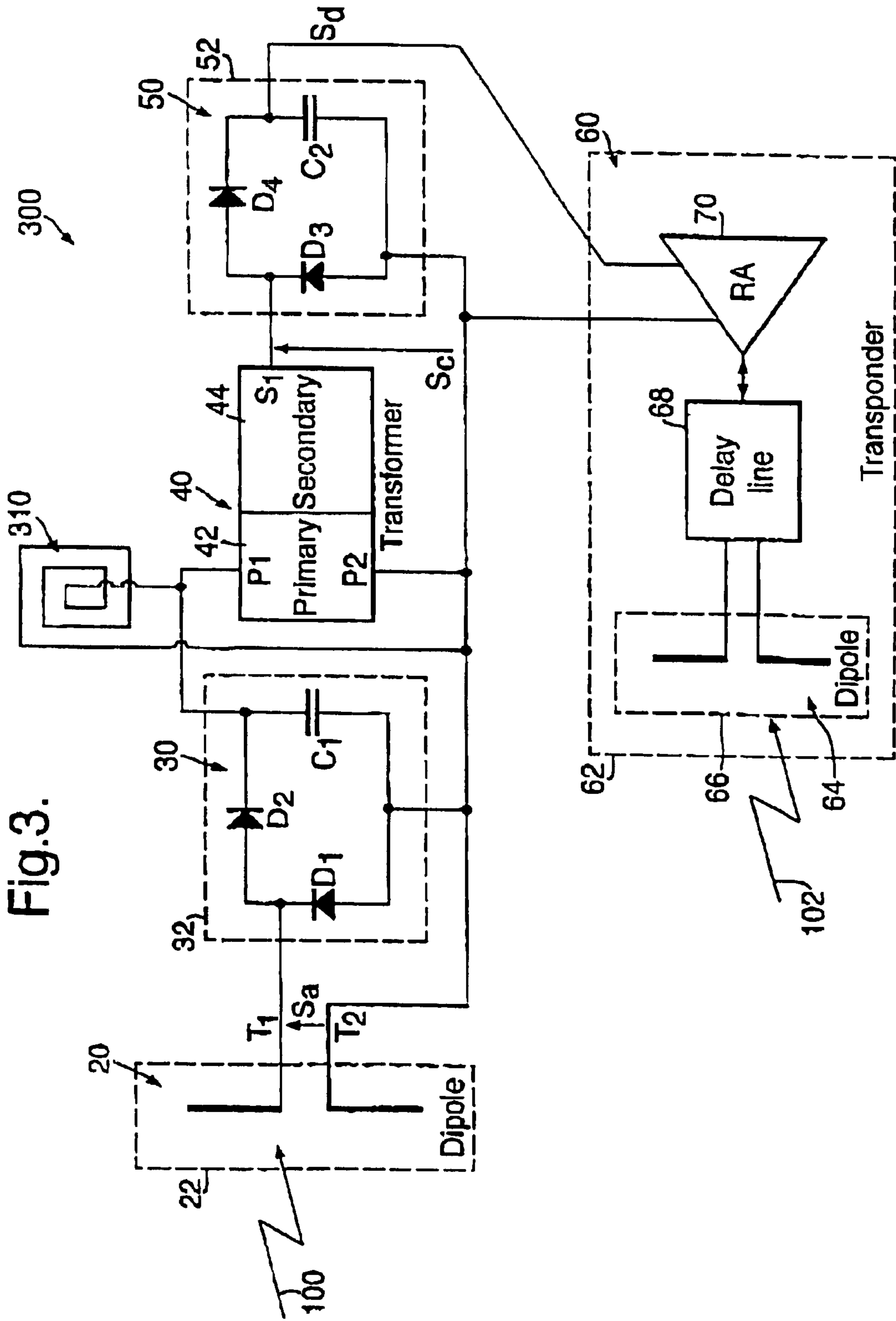
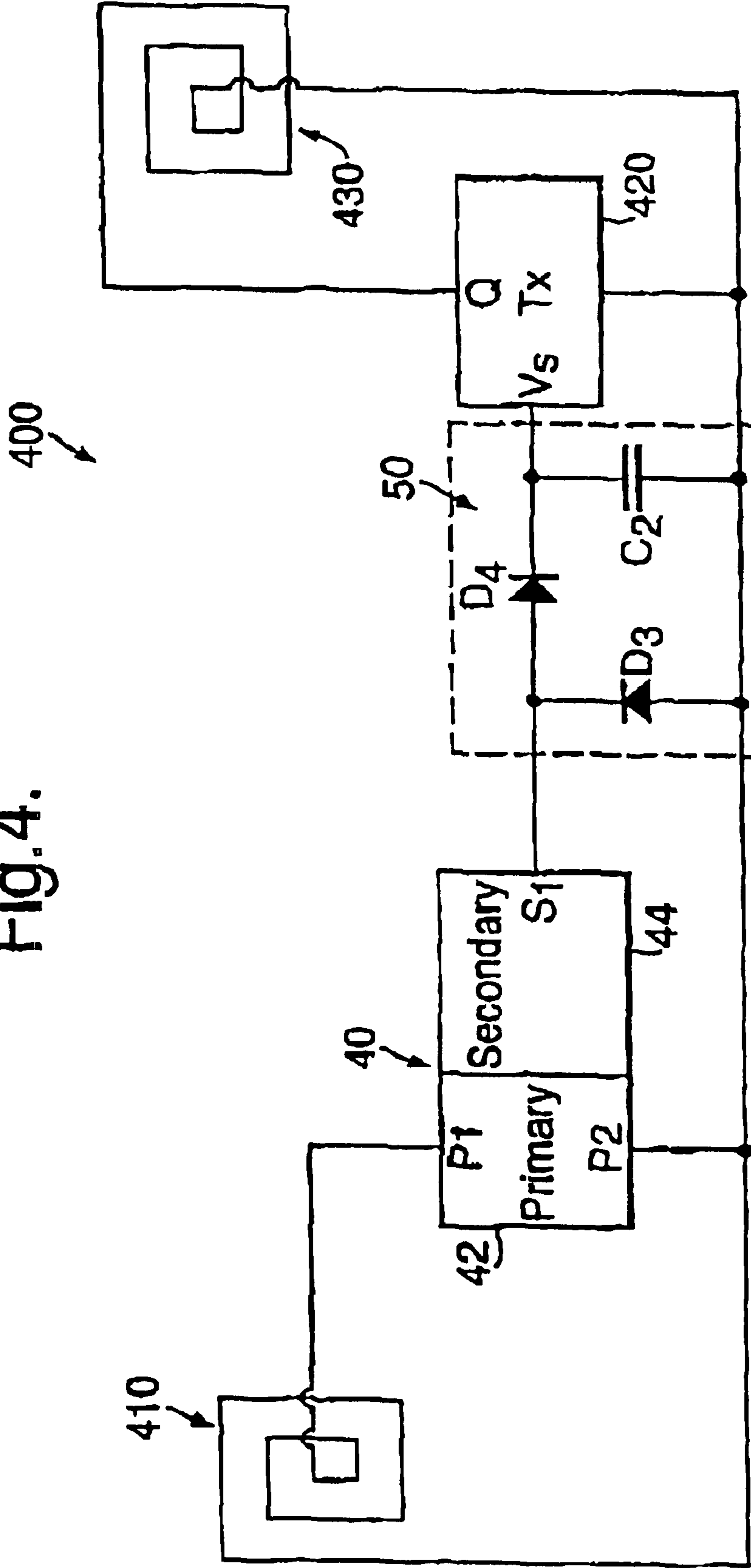

Fig. 4.



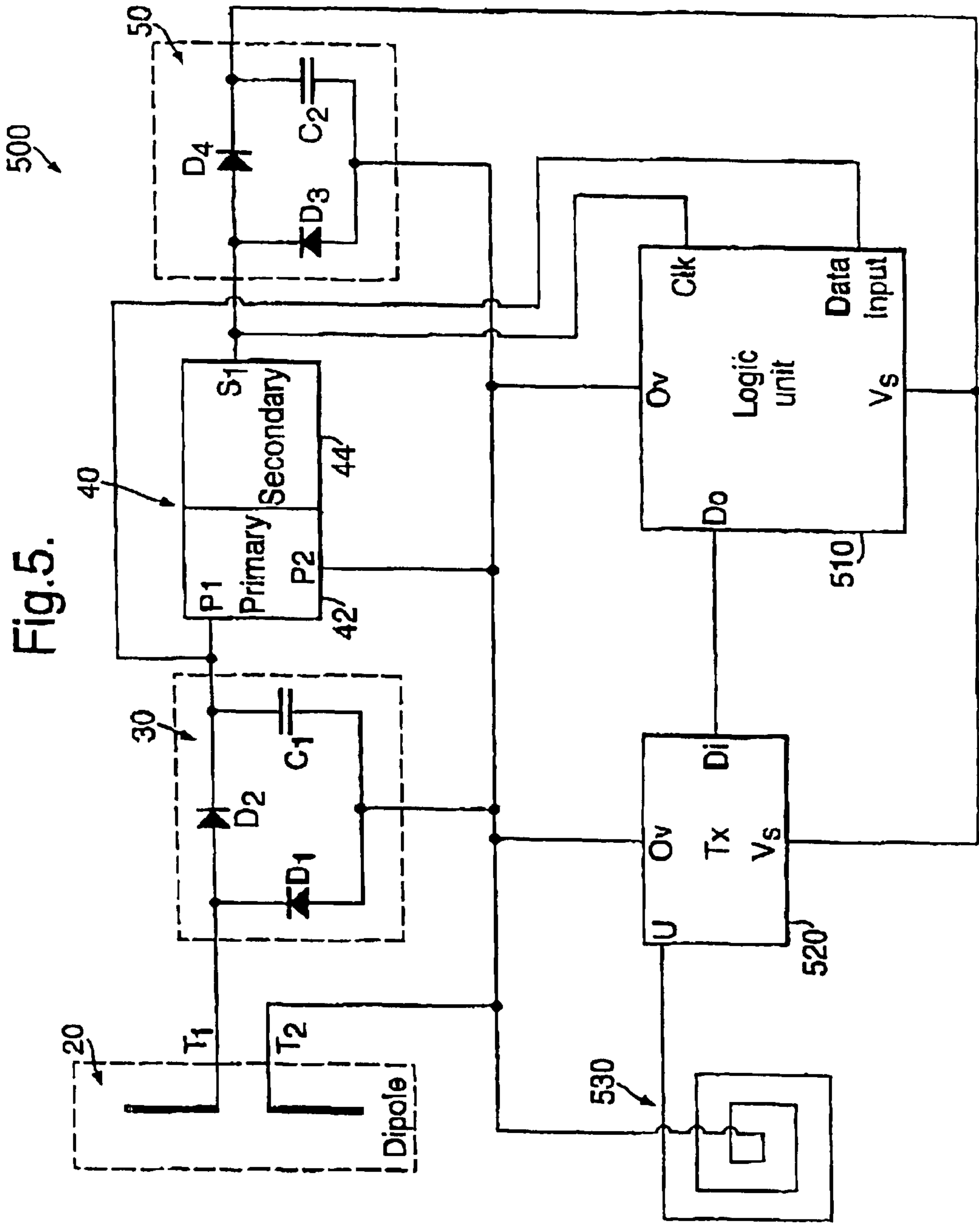
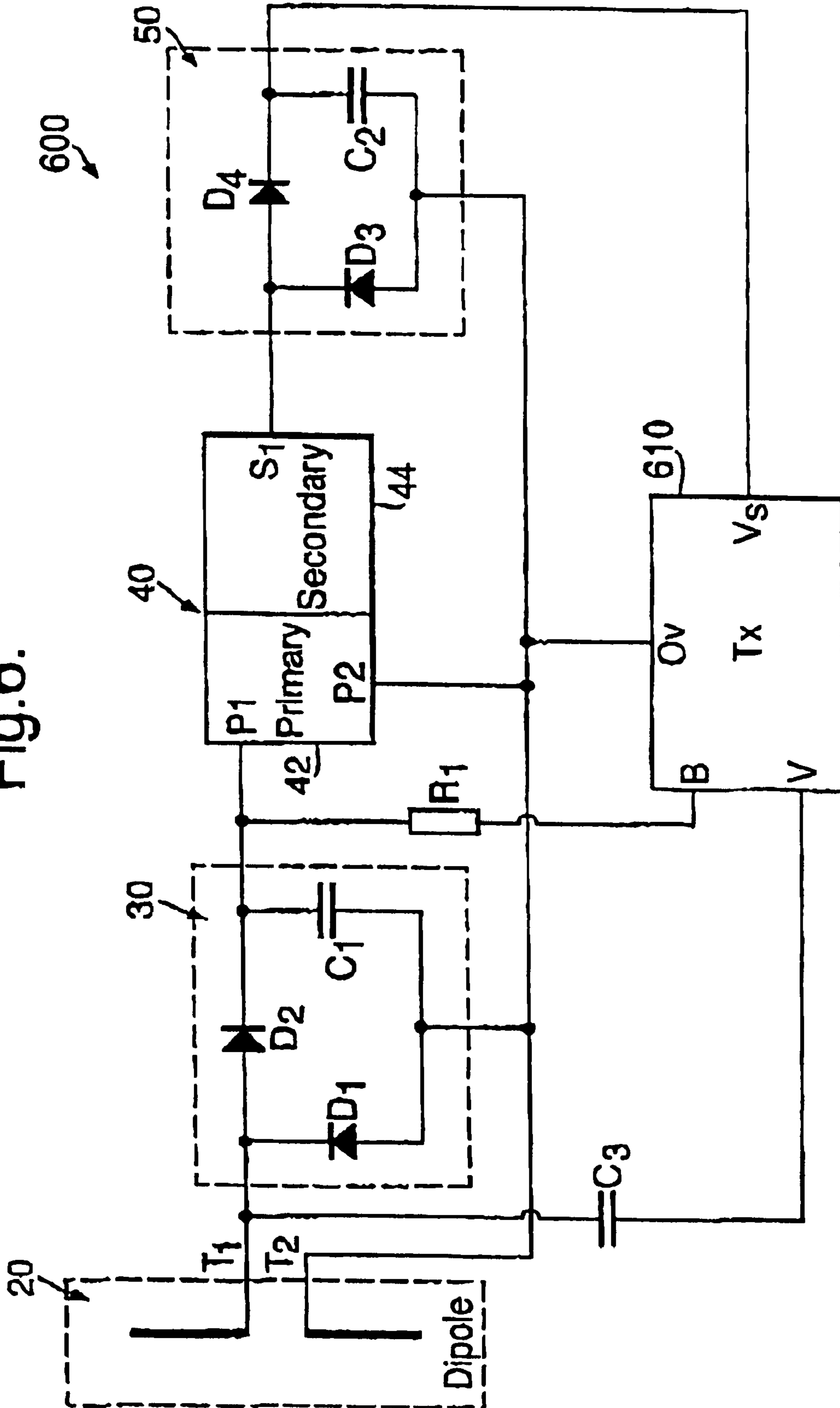

Fig. 5.

Fig. 6.



PIEZO-ELECTRIC TAG

Matter enclosed in heavy brackets [] appears in the original patent but forms no part of this reissue specification; matter printed in italics indicates the additions made by reissue.

This application is a 371 national stage entry of PCT/GB00/02944 dated Jul. 31, 2000, which claims priority to United Kingdom application 9917856.8 dated Jul. 29, 1999.

The present invention relates to a piezo-electric tag.

BACKGROUND OF THE INVENTION

Tags are portable devices which are capable of being attached to items or personnel wearable. They can be used, for example, for remotely identifying the items or receiving information therefrom. In many applications, the tags must be compact and be capable of responding after long periods of inactivity, for example where the tags are incorporated into items placed into storage for periods of several years.

Conventionally, tags can be passive devices which modify and reflect interrogating radiation directed thereto from associated interrogating sources. Because the tags do not provide power gain, their operating range from the sources is often limited to a few meters.

Active tags are known which incorporate onboard power sources such as a miniature electrical cell. Such power sources have a limited operating lifetime, especially if they are required to power their associated tags continuously. Moreover, the sources can make the tags unacceptably bulky for some applications, for example where tags are implemented as film strips for incorporating into spines of library books.

Although it is feasible to power tags from radiation incident thereupon, for example using solar cells incorporated into the tags or by inductively coupling energy from associated interrogating sources to the tags, it is not practicable in some circumstances to do this for safety reasons, for reasons of restricted operating range or for reasons of obscurity in the case of solar cells.

The use of received radio radiation for powering electronic tags is known in the art, for example as disclosed in a published patent application no. GB 2 306 081A. In the application, there is described a passive electrical power supply for providing electrical power to an electronic tag, the supply comprising an antenna for converting received radio frequency radiation into a first electrical signal, and a transformer including wire-wound coils for transforming the first signal into a second signal capable of altering the impedance of a field effect transistor (FET). In operation, the FET provides at its drain electrode a quasi half-wave rectified representation of the second signal which is converted to a unipolar signal by a capacitor connected to the drain electrode, the unipolar signal providing a power supply potential for operating the tag. The supply is operable to convert the received radiation into the unipolar signal such that the transformer operates at the frequency of the received radiation received at the antenna. The transformer can optionally be an autotransformer comprising a single wire-wound coil.

A power supply for a transponder is also disclosed in a published patent application no. GB 2 303 767 A. The supply described provides power to a response circuit of the transponder, the supply generating direct current (d.c.) from received electromagnetic energy. The supply comprises a

capacitor charged from a rectifier diode, the diode having a characteristic such that its reverse resistance against a reverse current directed at its n region to its p region is lower than its forward resistance against a reverse current directed from its p region to its n region. The diode is thus connected reversely compared to a conventional diode, its anode being connected to a positive plate of the capacitor. The arrangement allows the transponder to remain functional even when the received electromagnetic energy is relatively weak. The required characteristic for the diode can be implemented by the avalanche or tunnel effect. Moreover, a voltage multiplier may be provided by using a plurality of the diodes with associated capacitors for generating higher supply potentials. The supply does not employ any form of transformer for increasing the potential of signals generated in response to receiving the electromagnetic energy.

Piezo-electric transformers capable of stepping up potentials are also known in the art, for example as described in U.S. Pat. No. 5,828,160 and U.S. Pat. No. 5,389,852. Such transformers are operable to resonate at a frequency typically in a range of several tens of kHz to 300 kHz when stepping up potentials. This range of frequencies is considerably less than that used for electromagnetic radiation conventionally employed to interrogate electronic tags, for example 10 MHz to 30 GHz. Although piezoelectric transformers operating at frequencies above 300 kHz can be fabricated, for example 600 kHz, their cost and difficulty of fabrication renders them unattractive for items such as electronic tags.

Non-contact energy coupling schemes employing piezoelectric devices are known in other technical fields, for example as disclosed in a U.S. Pat. No. 5,749,909 concerning medically implanted devices. In the patent, there is described an energy transmission system for transmitting energy non-invasively from an external unit to an implanted medical device to recharge a battery in the medical device. An alternating magnetic field is generated by the external unit and a piezo-electric device in the implanted medical device vibrates in response to the magnetic flux to generate a voltage. The voltage is rectified and regulated to provide charging current to a rechargeable battery in the medical device. In the arrangement, the piezoelectric device is stimulated by the magnetic flux at a resonant frequency of the device, namely in the order of tens of kHz.

The inventor has appreciated that a principal problem associated with tags operated from radiation incident thereupon is that it is difficult to generate potentials on the tags of sufficient magnitude to operate semiconductor integrated circuits incorporated therein. Such circuits frequently require a supply potential of several volts to function.

SUMMARY OF THE INVENTION

The inventor has devised a tag which addresses this principal problem and which is operable, for example, from moderate levels of incident radiation thereupon in the order of 10 μ W. Such moderate levels of radiation rarely represent any health and safety risk.

According to a first aspect of the present invention, there is provided a piezoelectric tag including receiving means for receiving input radiation and generating a corresponding received signal, piezo-electric vibrating means for increasing voltage magnitude of the received signal to generate a supply potential and electronic circuit means powerable by the supply potential.

The invention provides the advantage that the vibrating means is capable of providing voltage magnification, thereby enabling the tag to be powered from radiation incident thereupon.

For the purpose of describing the invention, "microwave frequencies" means frequencies substantially in a range of 1 GHz to 30 GHz.

Advantageously, the vibrating means comprises a piezo-electric transformer incorporating mutually vibrationally coupled primary and secondary regions, the transformer operable to be excited into vibration by the received signal at the primary region and to generate a corresponding output signal at the secondary region for use in generating the supply potential.

The piezo-electric transformer provides the advantage that it is capable of being compact, inexpensive and providing a considerable increase in signal voltage amplitude from its primary region to its secondary region, the increase approaching 100 times or more.

Alternatively, the vibrating means comprises a piezoelectric bi-morph operable to be excited into vibration by the received signal and to generate a corresponding output signal for use in generating the supply potential.

As a further alternative, the vibrating means conveniently comprises a silicon micromachined device comprising an array of one or more resonant elements, each element incorporating an associated piezo-electric transducer operable to generate an element signal in response to vibration of its associated element, the transducers connected in series to add their element signals to provide an overall output from which the supply potential is generated, and driving means operable to be driven by the received signal for stimulating the one or more elements into vibration and thereby generating the supply potential.

The silicon device provides the advantage that it is capable of being mass-produced and being highly compact, for example 2 mm wide by 2 mm long by 0.6 mm thick.

Advantageously, the resonant elements in the silicon device are operable at resonance to generate the supply potential. Operation at resonance provides the benefit that voltage magnification in the device is greater than off-resonance.

Moreover, to obtain even greater voltage magnification, the resonant elements are housed in an evacuated environment. Operation in the evacuated environment increases Q-factor of the resonant elements, thereby increasing voltage magnification provided by the silicon device.

Conveniently, the receiving means in the tag incorporates demodulating means for demodulating modulation components present in the received radiation to generate the received signal. Inclusion of the demodulating means provides the benefit of signal frequency transformation, thereby enabling the tag to receive radiation providing power thereto at a different carrier frequency to the frequency of vibration required for exciting the vibrating means.

Advantageously, the demodulating means incorporates zero-bias Schottky diodes for demodulating the received radiation to generate the received signal. The zero-bias Schottky diodes provide the advantage of exhibiting a smaller forward conduction voltage drop compared to p-n silicon junction diodes, thereby enabling the tag to function with lower levels of received radiation power, for example 10 μ W.

Conveniently, the receiving means incorporates one or more conductive metallic film dipole antennas for one or more of receiving and emitting radiation. Such dipoles provide the advantage of being potentially compact and inexpensive to mass-produce.

The tag beneficially incorporates two antennas, one antenna for use in generating the received signal and the other incorporated into the responding means for at least one of emitting and receiving radiation. Incorporating two antennas provides the advantage that each antenna can be optimized to function at its respective radiation frequency. Conveniently, the antennas are conductive metallic film dipole antennas for reasons of increased compactness and reduced manufacturing cost. Alternatively, the antennas can also be patch antennas or loop antennas.

In some practical applications of the tag, it is advantageous that the tag is implemented in the form of a block, for example a cuboid block. This form provides the tag with enhanced mechanical robustness and thereby increases its reliability.

When the tag is personnel wearable or attachable to items of merchandise, it is convenient that the tag is in the form of a planar card. This form provides the advantage that the tag can be of similar size to existing planar cards, for example debit cards, thereby providing a degree of potential compatibility with existing card reading equipment.

When the tag is implemented in a planar card form, it conveniently incorporates recesses for accommodating the receiving means, the vibrating means and the responding means. Such recesses provide protection for the receiving means and the responding means, thereby making the tag more robust.

In the tag, the circuit means can comprise responding means for emitting output radiation from the tag, the responding means powerable by the supply potential. Incorporation of the responding means enables the tag to be remotely identified when interrogated.

Conveniently, the responding means is a transponder operable to receive input radiation to the tag and emit output radiation in response from the tag. Incorporation of the transponder enables the tag to be selectively responsive to interrogating radiation in an environment which is flood illuminated with radiation for exciting the vibrating means.

Advantageously, the transponder is operable to modulate the output radiation with a signature code by which the tag can be individually identified. The code enables the tag to be individually recognised which is highly advantageous where the tag is personnel wearable and used to identify its wearer, for example as in personal identification tags worn by employees in a commercial establishment.

When operating with high frequency radiation, for example at UHF frequencies from 300 MHz to 1 GHz and from microwave frequencies from 1 GHz to 30 GHz, the tag advantageously has the transponder incorporating a reflection amplifier for amplifying the input radiation to generate the output radiation. The reflection amplifier provides the advantage that it is capable of providing a high gain, for example in a range of +10 dB to +30 dB, for relatively low current consumption, for example in the order of a few microamperes.

Advantageously, especially when the transponder provides considerable gain, the transponder is operable in a pseudo-continuous mode and incorporates a delay line for delaying the output radiation relative to the input radiation, thereby counteracting spontaneous oscillation from arising within the transponder from feedback therein.

Conveniently, the tag is arranged such that the receiving means incorporates first and second antennas for generating the received signal for exciting the vibrating means, the first antenna adapted to respond to microwave radiation and the second antenna adapted to respond to radiation having a carrier frequency corresponding to a resonant frequency of the vibrating means. Incorporation of two antennas for gen-

5

erating the received signal provides the advantage that the tag is powerable from radiation having a number of possible carrier frequencies.

In a second aspect of the invention, there is provided a method of guiding a vehicle along a path to a destination, the method comprising the steps of:

- (a) distributing a plurality of tags according to the first aspect along the path and providing the vehicle with a direction sensitive interrogating source adapted to transpond with the tags;
- (b) interrogating the tags from the source by emitting radiation to the tags and receiving radiation therefrom, thereby determining direction of the tags relative to the source and hence determining the path;
- (c) moving the vehicle along the path; and
- (d) repeating steps (b) and (c) until the vehicle reaches the destination.

BRIEF DESCRIPTION OF THE DRAWINGS

Embodiments of the invention will now be described, by way of example only, with reference to the following diagrams in which:

FIG. 1 is a schematic of a first embodiment of the invention;

FIG. 2 is an exterior perspective view of the first embodiment shown in FIG. 1;

FIG. 3 is an illustration of a second embodiment of the invention;

FIG. 4 is an illustration of a third embodiment of the invention incorporating a simplified circuit utilising loop antennas;

FIG. 5 is an illustration of a fourth embodiment of the invention adapted for operating with Manchester encoded signals; and

FIG. 6 is an illustration of a fifth embodiment of the invention incorporating a single antenna for use in emitting and receiving radiation.

DETAILED DESCRIPTION OF THE PREFERRED EMBODIMENTS

Referring to FIG. 1, there is shown a piezo-electric tag according to a first embodiment of the invention indicated by 10. The tag 10 incorporates a number of sections, namely a first dipole antenna indicated by 20 and included within a dotted line 22, a first rectification circuit indicated by 30 and included within a dotted line 32, a piezoelectric transformer indicated by 40 incorporating a primary region 42 and a secondary region 44, a second rectification circuit indicated by 50 and included within a dotted line 52, and a transponder circuit indicated by 60 and included within a dotted line 62. The sections are incorporated into a plastic card having external dimensions of 55 mm width, 85 mm length and 1 mm thickness; this will be further described later with reference to FIG. 2.

The transponder 60 incorporates a dipole antenna indicated by 64 and included within a dotted line 66, a bi-directional surface acoustic wave (SAW) delay line 68 and a reflection amplifier 70.

The first dipole antenna 20 is connected to an input of the first rectification circuit 30. The circuit 30 includes an output which is connected to the primary region 42 of the transformer 40. The secondary region 44 thereof is connected to an input of the second rectification circuit 50. The second circuit 50 incorporates an output which is connected to a power supply input to the transponder 60.

6

Operation of the tag 10 will now be described in broad overview after which its sections will be described in further detail.

The antenna 20 receives incoming radiation 100 from an interrogating source (not shown). The radiation 100 has a carrier frequency of 1 GHz which is amplitude modulated to a modulation depth in a range of 50% to 100% by a modulating signal which has a frequency of 300 kHz. Moreover, the radiation 100 has a power density of 5 mW/m² at the antenna 20. The radiation 100 couples to the antenna 20 and generates a corresponding signal S_a across output terminals T_1, T_2 of the antenna 20; the signal S_a has a frequency of 1 GHz and an amplitude in the order of 80 mV. The signal S_a propagates to the first circuit 30 which demodulates it and then filters it to substantially remove signal components above 1 MHz to generate a unipolar modulated signal S_b having signal components at 300 kHz. The transformer 40 receives the signal S_b across its primary region terminals P_1, P_2 . The signal S_b stimulates the primary and secondary regions 42, 44 to resonate at 300 kHz in their longitudinal mode of vibration. At resonance, the transformer 40 magnifies the signal S_b received at its primary region 42 to generate a bipolar alternating signal S_c at a secondary region terminal S_1 , the signal S_c having an amplitude in the order of 3 volts. The second circuit 50 receives the signal S_c and demodulates and filters it to generate a substantially smoothed unipolar signal S_d at an output terminal of the circuit 50. The transponder 60 receives the signal S_d and uses it as a supply potential to power active circuits incorporated therein.

The transformer 40 provides the advantage of performing a step-up voltage conversion function from its primary region 42 to its secondary region 44 at resonance, thereby providing the signal S_d of sufficient magnitude of several volts to power active electronic devices incorporated into the transponder 60, namely the reflection amplifier 70. Although the transformer 40 cannot provide power gain, it is effective to provide an impedance conversion for matching an input impedance presented by the second circuit 50 to an output impedance presented by the first circuit 30; the signal S_d of relatively lower voltage amplitude from the antenna 20 which is unsuitable for powering circuits is thereby converted into the signal S_d of relatively high voltage, namely several volts, which is suitable for powering circuits.

The transponder 60 receives incoming continuous-wave radiation 102 from the interrogating source. The radiation 102 has a carrier frequency of 1.5 GHz. In response to receiving the radiation 102, the antenna 64 generates a corresponding signal S_e at its terminals which passes to the delay line 68 and propagates therethrough whilst being delayed therein to provide a signal S_f at an input to the reflection amplifier 70. The amplifier 70 presents a modulated negative resistance at its input/output terminal and thereby reflectively amplifies the signal S_f to generate a corresponding modulated amplified signal S_g . The signal S_g propagates back through the delay line 68 whilst being delayed therein to the antenna 64 from where it is emitted as return radiation. The interrogating source receives the return radiation and determines that it is modulated, thereby detecting the presence of the tag 10.

The tag 10 provides the benefit that it is capable of providing the modulated return radiation without there being a need for the tag 10 to incorporate limited lifetime power sources such as batteries for powering its active circuits. Avoidance of the need for batteries provides the tag 10 with a potentially useable lifetime of several decades or more. Thus, the tag 10 is thereby suitable for attachment to products which are to be stored for lengthy periods of time, for example several years.

Sections of the tag 10 will now be described in more detail.

The antenna **20** is a thin film dipole formed by conductive tracks on a major surface of the card. The terminal T_2 of the antenna **20** is connected to a signal ground on the card, and the terminal T_1 is connected to the first circuit **30**.

The circuit **30** incorporates two zero-bias Schottky diodes D_1, D_2 and a filter capacitor C_1 . The diode D_2 is connected by its anode to the diode D_1 at its cathode to form an input terminal; the terminal is connected to the terminal T_1 of the antenna **20**. The diode D_2 is connected at its cathode to a first terminal of the capacitor C_1 . The capacitor C_1 incorporates a second terminal which is connected to the signal ground. The diode D_1 incorporates an anode which is also connected to the signal ground.

The diodes D_1, D_2 are operable to provide signal rectification at microwave frequencies, for example 1 GHz, and be responsive to signal amplitudes in the order of mV. They incorporate metal-semiconductor junctions for performing rectification. Ordinary p-n silicon junction diodes are not as desirable for use in substitution for the diodes D_1, D_2 because of their relatively greater voltage drop when operating under forward bias. The capacitor C_1 is operable to shunt signal components at microwave frequencies to the signal ground. An output from the circuit **30** is extracted from across the capacitor C_1 , namely from the first terminal of the capacitor C_1 relative to the signal ground.

The transformer **40** is fabricated from a hard piezoelectric lead zirconate titanate (PZT) material whose dielectric loss coefficient is less than 0.02; the dielectric loss coefficient is defined as a ratio of energy dissipated per cycle to energy stored per cycle. It has exterior dimensions of 3 mm width, 6 mm length and 1 mm thickness and is therefore of an elongate form having an elongate axis. In operation, it is designed to periodically vibrate in a longitudinal manner along the elongate axis at a resonant frequency of approximately 300 kHz. The primary region **42** comprises a multilayer stack of piezoelectric elements, each element having exterior dimensions of 3 mm length, 3 mm width and 0.1 mm thickness and polarised in its thickness direction. The secondary region **44** comprises a single element having exterior dimensions of 3 mm width, 3 mm length and 1 mm thickness; the region **44** is polarised in a direction parallel to the elongate axis when assembled in the transformer **40**. The elements of the primary region **42** and the second region **44** are mutually joined by sintering them together or using an epoxy resin of comparable rigidity to the PZT material.

In operation, the transformer **40** exhibits a longitudinal resonance mode at 300 kHz frequency having an associated Q-factor in the order of 100. It functions at its resonance to magnify the voltage amplitude of signals applied to its primary region **42** by generating corresponding signals at its secondary region **44** of relatively greater voltage amplitude. This magnification arises at the expense of reduced signal current at the secondary region **44** compared to the primary region **42**; in other words, the transformer **40** provides an impedance match but does not impart power gain.

The circuit **50** employs an identical configuration to the circuit **30**. The capacitor C_1 and the diodes D_1, D_2 in the circuit **30** correspond to a capacitor C_2 and diodes D_3, D_4 in the circuit **50** respectively.

The reflection amplifier **70** of the transponder **60** is connected at its power supply connections to the signal ground and to the first terminal of the capacitor C_2 which is not connected to the signal ground. Electrical power is thereby supplied to the amplifier **70** in operation.

The reflection amplifier **70** incorporates a switching oscillator which periodically switches reflective gain provided by the amplifier **70** between a high gain state and a low gain state.

The oscillator is operable to switch the amplifier **70** in a cyclical manner between the high gain state for a period of 2τ and the low gain state for a period of 2τ . In the low gain state, the amplifier **70** is incapable of sustaining spontaneous oscillation within the transponder **60**. The period of 2τ corresponds to twice a time duration for signals to propagate in one direction through the delay line **68**. Periodic switching of gain provided by the amplifier **70** counteracts the formation of spontaneous oscillation within the transponder **60** because amplified signals from the amplifier **70** are reflected from the antenna **64** and return to the amplifier **70** when it is switched to its low gain state. In its high gain state, the amplifier **70** provides +23 dB gain which could result in the formation of spontaneous oscillation if the amplifier **70** were not periodically gain switched to the lower gain state as described above.

Referring now to FIG. 2, there is provided an exterior perspective illustration of the tag **10**. The tag **10** incorporates a non-conducting plastic substrate layer **200** having first and second major faces. Onto the first major face is bonded a conductive earth-plane layer **210** of aluminum material in a range of 30 μm to 100 μm thick. The layers **200, 210** have a length of 85 mm in an x-direction indicated by an arrow **212**, and a width of 55 mm in a y-direction indicated by an arrow **214**. The layer **200, 210** have a combined thickness of 1 mm in a z-direction indicated by an arrow **216**.

The substrate layer **200** incorporates recesses **230, 240, 250, 260** moulded there into to accommodate the circuits **30, 50**, the transformer **40**, the amplifier **70** and the delay line **68** respectively. Being elongate, the tag **10** has an elongate axis in the x-direction. At first and second elongate ends of the tag **10**, there are formed the antennas **20, 64** respectively. The antennas **20, 64** are both bow-tie dipole antennas incorporating deposited metallic regions formed onto the second major face of the layer **200**. Connecting conductive tracks are also formed on the second major face to connect the antennas **20, 64** to the circuits **30, 50** and the delay line **68** respectively. Further tracks are included to connect the circuits **30, 50** to the transformer **40** and the amplifier **70**, and the delay line **68** to the amplifier **70**. Wire bonding techniques are employed for bonding from the tracks to the recesses **230, 240, 250, 260**.

When fabricated, a 100 μm thick protective plastic layer (not shown) is added onto the second major face to protect the antennas **20, 64**, the tracking, the circuits **30, 50**, the transformer **40**, the amplifier **70** and the delay line **68**. Graphical information for example optically readable bar codes or a photographic image, can be optionally printed onto the protective layer. The photographic image is particularly relevant when the tag **10** is personnel wearable and used as a remotely interrogatable identity tag.

Referring now to FIG. 3, there is shown a piezoelectric tag according to a second embodiment of the invention indicated by **300**. The tag **300** is identical to the tag **10** except that it additionally includes a planar coil **310** in parallel connection with the capacitor C_1 .

The earth plane layer **210** can be selectively absent in a vicinity of the coil **310** so as not to excessively screen the coil **310**. The coil **310** is formed onto the second major face of the layer **200** shown in FIG. 2 adjacent to the circuits **30, 50** and the transformer **40**. The capacitor C_1 , in parallel with an electrical capacitance presented by the transformer **40** between its terminals P_1, P_2 , and the coil **310** are operable to parallel resonate at the resonant frequency of the transformer **40**, namely 300 kHz. Inclusion of the coil **310** enables the tag **300** to be powered not only from 1 GHz radiation received at the antenna **20** but also from inductively coupled magnetic fields at 300 kHz coupling to the coil **310**. The tag **300** can thereby be powered in two different modes so that it can be

used in environments where radiation at either or both frequencies, 300 kHz and 1 GHz, are present; for example, in environments where microwave radiation cannot be tolerated for safety reasons.

As an alternative to using the diodes D1 to D4 in the tags 10, 300, FETs functioning as asynchronous detectors may be employed. FETS operating in this mode exhibit a voltage drop thereacross in the order of microvolts.

Moreover, the antennas 20, 64 may be substituted by a single patch antenna or a single loop antenna operable to receive and emit radiation and convey signals to the circuit 30, and to and from the delay line 68. Although the tags 10, 300 are described as being receptive and emissive at radiation frequencies of 1 GHz and 1.5 GHz, they can be operated at other microwave frequencies by modifying dimensions of features of the antennas 20, 64 and the delay line 68. At microwave frequencies in excess of 10 GHz, the delay line 68 is advantageously replaced by a magnetostatic wave delay line (MWDL), for example a delay line incorporating a film of yttrium iron garnet (YIG) providing a signal propagation path in the delay line.

Furthermore, the tags 10, 300 can be modified by replacing the transponder 60 with, for example, a simple oscillator emitting through its antenna encoded radiation unique to the oscillator, thereby enabling the tags 10, 300 when modified to be uniquely identified from the radiation emitted therefrom. Additionally, the transponder 60 can be operable to emit radiation during a first period and be inactive during a second period, the transponder arranged to switch cyclically between the first and second period; this provides the advantage that the transponder 60 can respond by emitting bursts of relatively more powerful radiation during the first period and conserve energy during the second period.

FIG. 4 illustrates a piezoelectric tag indicated by 400 which incorporates a simplified circuit utilising a first loop antenna 410 for receiving radiation, a transmitter module (TX) 420 and a second loop antenna 430 for emitting radiation. The tag 400 further comprises the transformer 40 and the second rectification circuit 50. In a similar manner to the tags 10, 300, the tag 400 is powered from radiation incident thereupon.

The antenna 410 includes first and second connections, the first connection connected to a signal earth plane of the tag 400 and the second connection connected to the terminal P₁ of the transformer 40. The terminal P₂ of the transformer 40 is connected to the signal earth plane. The terminal S₁ of the transformer 40 is connected to the circuit 50, and the output from the circuit 50 is connected to a V_S power input of a pulsed transmitter 420. The transmitter 420 is also connected to the signal earth plane. Moreover, the transmitter 420 includes an output Q which is connected to a first connection of the antenna 430. A second connection of the antenna 430 is connected to the signal earth plane.

The antenna 410 provides an inductance at its connections which is arranged to electrically resonate with a capacitance exhibited by the transformer 40 across its terminals P₁, P₂ at a frequency corresponding to input radiation to the tag 400 and also to a vibrational mode of the transformer 40 when functioning to increasing signal voltage from its primary region to its secondary region. The transmitter 420 incorporates a transistor biased into class C mode of operation such that it only conducts for part of a signal cycle when functional when an output from the circuit 50 to the transmitter 420 exceeds a threshold value. When the output from the circuit 50 is less than the threshold value, the transistor is non-conducting, thereby conserving power and providing the circuit 50 with maximum opportunity to develop a potential.

Operation of the tag 400 will now be described with reference to FIG. 4. The antenna 410 receives radiation incident on the tag 400 at a frequency of 300 kHz and provides a 300 kHz signal across the terminals P₁, P₂ which excites the transformer 40 into resonance. The transformer 40 provides a voltage stepped-up signal at a frequency of 300 kHz at its secondary terminal S₁. The signal passes to the circuit 50 which rectifies it to provide a d.c. potential across the capacitor C₂. This potential is supplied to the transmitter 420 at its V_S power input. When the potential exceeds a value of 2 volts relative to the signal earth, the transmitter 420 becomes active and generates at its output Q an output signal in the form of bursts of signal, each burst comprising a sequence of 500 kHz pulses, each burst having a duration of 50 μsec and the bursts having a repetition rate of 2 Hz. The output signal couples from the transmitter 420 to the antenna 430 from where it is emitted as radiation.

The tag 400 provides the advantage that it is simpler and potentially cheaper to manufacture than the tags 10, 300. When the tag 400 is manufactured in volume, the transmitter 420 of each tag 400 can be customized to generate bursts of 500 kHz radiation at a repetition rate unique to the tag 420, thereby distinguishing it from other tags of identical design. Class C operation provides the advantage that the transistor does not consume power until radiation above a threshold amplitude is received at the tag 400 which causes the transistor to be driven into an active region of its characteristics.

Modifications can be made to the tag 400 without departing from the scope of the invention. For example, the transformer 40 can be replaced by a piezoelectric vibrating bi-morph or a silicon micromachined vibrating structure capable of providing an increased signal voltage at its secondary region relative to its primary region.

Referring now to FIG. 5, there is shown a tag indicated by 500 for operating with Manchester bi-phase encoded signals. The tag 500 comprises the antenna 20, the circuits 30, 50, and the transformer 40. It further comprises a logic unit 510 and a transmitter 520 linked to a loop antenna 530. The antenna 20 is connected to the circuit 30 which is in turn connected to the transformer 40 and then to the circuit 50 in an identical manner to the tag 10. An output from the circuit 50 generated across the capacitor C₂ is connected to the logic unit 510 and the transmitter 520. Inputs Clk and "Data input" of the unit 510 are connected to the terminals S₁ and P₁ of the transformer 40 respectively.

The unit 510 incorporates an output D_o which is connected to an input D_i of the transmitter 520. The transmitter 520 includes an output U which is connected to one connection of the antenna 530; another connection of the antenna 530 is connected to a signal earth of the tag 500.

A Manchester bi-phase encoded signal M will now be described. A digital data signal D has two states corresponding to logic 0 and logic 1. The signal D switches between these two states to convey a stream of data comprising 0's and 1's. The signal D remains in either of the two states for periods of not less than 2τ where τ is a time constant. The signal D is then exclusive-ORed with a clock signal K having a frequency of 1/2τ to generate the signal M. The advantage of the Manchester bi-phase signal is that it is constantly changing even when the signal is in a constant 0 or 1 state.

Operation of the tag 500 will now be described decoding the signal M. Radiation having a carrier frequency of 1 GHz and modulated by the signal M is received at the antenna 20 which generates a corresponding 1 GHz modulated signal. The circuit 30 demodulates the 1 GHz signal to generate the signal M at the terminal P₁ of the transformer 40. The clock signal K is arranged to have a principal frequency component

corresponding to a resonance mode of the transformer **40** at which it provides voltage increase from its primary region **42** to its secondary region **44**. Because the transformer **40** exhibits a relatively narrow resonance peak, it is effective at stripping out the signal D from the signal M to output predominantly the signal K at the terminal S_1 . The signal at the terminal S_1 then passes to the circuit **50** which rectifies it to generate a d.c. potential across the capacitor C_2 . The potential passes to power supply inputs V_S of the unit **510** and the transmitter **520** to apply power thereto. The signal M present at the terminal P1 and the signal K present at the terminal S_1 are also conveyed to the inputs Clk and "Data input" respectively of the unit **510** which performs an exclusive-OR function to recover the signal D which is then output at the output D_o . The signal D propagates from the unit **510** to the transmitter **520** which is controlled by data conveyed in the signal D. The transmitter **520** responds to the data by emitting modulated 1 MHz radiation from the antenna **530**.

The tag **500** provides the advantage that the transformer **40** performs a dual function, namely to generate a supply potential to power the tag **500** and also to provide signal filtration.

In order to reduce manufacturing cost and increase compactness, the inventor has appreciated that it is desirable that a tag should only incorporate a single antenna for both receiving and emitting radiation. In FIG. 6, there is shown a tag indicated by **600** incorporating the antenna **20** and operable to both emit radiation therefrom and receive radiation thereat. The tag **600** further comprises the circuits **30**, **50**, the transformer **40** and a transmitter (TX) **610**. The terminals T_1 , T_2 of the antenna **20** are connected to an input to the circuit **30** and to a signal earth respectively. An output from the circuit **30** is connected to the terminal P_1 of the transformer **40**. The terminal P_2 of the transformer **40** is connected to the signal earth. An output B of the transmitter **610** is connected through a resistor R_1 to the terminal P_1 of the transformer **40**. The secondary terminal S_1 of the transformer **40** is connected to the circuit **50** in a similar manner to the tag **10**. Moreover, the transmitter **610** further comprises an output V which is coupled through a capacitor C_3 to the terminal T_1 of the antenna **20**.

Operation of the tag **600** will now be described with reference to FIG. 6. Initially, the transmitter **610** is not energised such that its output B is at a potential of the signal earth. Radiation having a carrier frequency of 1 GHz and modulated with a signal of 300 kHz is received at the antenna **20** which generates a corresponding signal across its terminals T_1 , T_2 . The signal is rectified to generate a 300 kHz signal across the capacitor C_1 which then passes to the primary region **42** of the transformer **40** to excite it into resonance. The transformer **40** generates a voltage-enhanced output signal at a frequency of 300 kHz at the terminal S_1 which is subsequently demodulated by the circuit **50** to provide a potential for operating the transmitter **610**.

The transmitter **610** functions to generate 100 μ sec duration bursts of 1 GHz signal at a repetition rate of 2 Hz at its output V. When the transmitter **610** is about to emit a burst of 1 GHz radiation from the antenna **20**, it firstly switches its output B to a potential approaching that supplied by the circuit **50** which reverse biases the diodes D_1 , D_2 thereby disabling the circuit **30**. The transmitter then outputs a burst signal through the capacitor C_3 to the antenna **20** from whence it is radiated as radiation. At the end of the burst signal, the transmitter switches its output B back to a potential of the signal earth so that the circuit **30** can continue to function to keep the capacitor C_2 charged until a next burst of radiation is to be emitted.

The tag **600** provides a further advantage that, because only one antenna **20** is required, the antenna **20** can, if required, be enlarged to occupy a majority of a major surface area of the tag **600**. Such enlargement is not possible to achieve when two or more antennas are incorporated into a tag, each antenna requiring more than 50% of the major surface area of the tag **600**.

It will be appreciated by one skilled in the art that modifications can be made to the tags **10**, **300**, **400**, **500**, **600** without departing from the scope of the invention.

For example, the tags **10**, **300**, **400**, **500**, **600** can be moulded into a plastic block rather than being implemented in card-like form as illustrated in FIG. 2. The block is a more robust shape compared to a card, thereby enabling the tags **10**, **300**, **400**, **500**, **600** in block form to be deployed in rugged environments, such as for marking out a path in a smoke-filled burning building. A block is distinguishable from a card in that the ratio of the block's length, width and thickness dimensions are less than 1:3. A block form also includes a cuboid form, a pyramidal form and a near-spherical or spherical form.

As an alternative to using the diodes D1 to D4 in the tags **10**, **300**, **400**, **500**, **600**, FETs functioning as asynchronous detectors may be employed. FETs operating in this mode exhibit a voltage drop thereacross in the order of microvolts which is less than a forward bias voltage drop associated with diodes.

The tags **10**, **300**, **400**, **500**, **600** can be used as personnel wearable identity tags. They may be attached to items of merchandise and used in conjunction with an associated interrogating source to provide a merchandise anti-theft system.

The tags **10**, **300**, **400**, **500**, **600** can be used in a similar manner to "magic eye" reflectors used to delineate lanes on motorways; a plurality of the tags **10**, **300**, **400**, **500**, **600** can be employed as interrogatable markers for marking out a path. Such use is potentially valuable, for example, for defining routes for automatically guided robotic vehicles around manufacturing and storage sites. The guided vehicles can be equipped with interrogating sources which are sensitive to direction of radiation emitted from the tags **10**, **300**, **400**, **500**, **600** thereby defining direction of the tags **10**, **300**, **400**, **500**, **600** relative to the vehicles. Each tag **10**, **300**, **400**, **500**, **600** can be provided with its own unique signature code, thereby enabling the vehicle to determine its position along the path from the signature codes. Such a method of vehicle guidance is preferable to wire guided vehicle systems where greater installation cost can arise when installing guiding wires compared to distributing tags.

In the tags **10**, **300**, **400**, **500**, **600**, the transformer **40** can be replaced by an alternative piezo-electric device operable to increase voltage. One example of an alternative piezo-electric device is a ceramic bi-morph in the form of an elongate member supported at one of its ends and free to vibrate at its other end; such a bi-morph is capable of exhibiting a higher Q-factor than the transformer **40**, thereby providing an enhanced voltage increase. Another example of an alternative piezo-electric device is a micromachined silicon device comprising an array of one or more suspended silicon cantilevers, each cantilever incorporating a deposited film piezo-electric transducer operable to generate a signal in response to vibration of the cantilever. The transducers are connected in series to add their signal voltages together to provide an overall output for the circuit **50**. An excitation transducer operable to be driven by a drive signal from the circuit **30** is also incorporated for mechanically exciting the one or more cantilevers into vibration, preferably at resonance of the cantilevers. Sili-

13

con cantilevers are capable of exhibiting high resonance Q-factors approaching several million when operating in a miniature evacuated housing, thereby providing a considerable increase in signal voltage amplitude at the overall output compared to the drive signal. Silicon micromachining is a well known mass production process and involves fabrication of mechanical structures in silicon material using batch lithographic, deposition and etching techniques.

The tags **10, 300, 400, 500, 600** can be modified to include other types of electronic circuits, for example memory circuits and environmental sensors, for example radiation and chemical sensors. Such electronic circuits enable the tags to function as miniature personal data loggers which are personnel wearable and useable for monitoring the safety of personnel in working environments, for example in chemical laboratories where hazardous chemicals are handled.

The tags **10, 300, 400, 500, 600** can be further miniaturised and adapted for inclusion within biological systems, for example for use as remotely controlled insulin dispensers, as heart-stimulating pace-makers or as artificial retinas. Use of piezo-transformers powered from received modulated radiation avoids the need for batteries in the tags and thereby enables the tags to be implanted permanently within biological systems without needing to be periodically removed.

What is claimed is:

1. A piezo-electric tag, comprising:

[a] receiving means for receiving input radiation and generating a corresponding received signal;

[b] piezo-electric vibrating means for increasing voltage magnitude of the received signal to *continuously* generate a supply potential *while the input radiation is being received*; and

[c] electronic circuit means powerable by the supply potential, *wherein the electronic circuit means is continuously coupled to the piezo-electric vibrating means to receive the supply potential*.

2. The tag according to claim 1, wherein the vibrating means comprises a piezo-electric transformer incorporating mutually vibrationally coupled primary and secondary regions, the transformer being operable to be excited into vibration by the received signal at the primary region and to generate a corresponding output signal at the secondary region for use in generating the supply potential.

3. A tag according to claim 1, wherein the vibrating means comprises a piezo-electric bi-morph operable to be excited into vibration by the received signal and to generate a corresponding output signal for use in generating the supply potential.

4. The tag according to claim 1, wherein the vibrating means comprises a silicon micromachined device comprising an array of resonant elements, each element incorporating an associated piezo-electric transducer operable to generate an element signal in response to vibration of its associated element, the transducers being connected in series to add their element signals to provide an overall output from which the supply potential is generated, and driving means operable to be driven by the received signal for stimulating the elements into vibration and thereby generating the supply potential.

5. The tag according to claim 4, wherein the resonant elements are operable at resonance to generate the supply potential.

6. The tag according to claim 4, wherein the resonant elements are housed in an evacuated environment for increasing their resonance Q factor.

14

7. The tag according to claim 1, wherein the receiving means incorporates demodulating means for demodulating modulation components present in the received radiation to generate the received signal.

8. The tag according to claim 7, wherein the demodulating means incorporates zero-bias Schottky diodes for demodulating the received radiation to generate the received signal.

9. The tag according to claim 7, wherein the demodulating means incorporates transistors operable as synchronous demodulators for demodulating the received radiation to generate the received signal.

10. The tag according to claim 1, wherein the circuit means is operable to function in a class C mode for reducing tag power consumption.

11. The tag according to claim 1, wherein the receiving means incorporates first and second antennas for generating the received signal for exciting the vibrating means, the first antenna being adapted to respond to microwave radiation, and the second antenna being adapted to respond to radiation having a carrier frequency corresponding to a resonant frequency of the vibrating means.

12. The tag according to claim 1, wherein the receiving means incorporates at least one of a metallic film dipole antenna, a loop antenna and a patch antenna for at least one of receiving and emitting radiation.

13. The tag according to claim 1, wherein the circuit means comprises responding means for emitting output radiation from the tag, the responding means being powerable by the supply potential.

14. The tag according to claim 13, wherein the vibrating means is operable to recover a clock component of Manchester bi-phase encoded radiation received at the tag, and wherein the responding means is operable to use the clock component to demodulate the encoded radiation to generate corresponding demodulated data for use in the tag.

15. The tag according to claim 13, wherein the tag incorporates two antennas, one antenna for use in generating the received signal, and the other antenna incorporated into the responding means for at least one of emitting and receiving radiation.

16. The tag according to claim 13, wherein the antennas are conductive metallic film dipole antennas.

17. The tag according to claim 1, the tag having a form of a block.

18. The tag according to claim 1, the tag having a form of a planar card.

19. The tag according to claim 18, wherein the card incorporates recesses for accommodating the receiving means, the vibrating means and the responding means.

20. The tag according to claim 13, wherein the responding means is a transponder operable to receive input radiation to the tag and emit output radiation in response from the tag.

21. The tag according to claim 20, wherein the transponder is operable to modulate the output radiation with a signature code by which the tag is individually identified.

22. The tag according to claim 20, wherein the transponder incorporates a reflection amplifier for amplifying the input radiation to generate the output radiation.

23. The tag according to claim 20, wherein the transponder is operable in a pseudo-continuous mode and incorporates a delay line for delaying the output radiation relative to the input radiation, thereby counteracting spontaneous oscillation from arising within the transponder from feedback therein.

24. The tag according to claim 1, and a metallic earthing plane for providing a common signal earth for the tag.

25. The tag according to claim 1, and means for implantation into a biological system and operable for at least one of monitoring and stimulating the biological system.

26. *A wireless communication device, comprising:*
a receiver circuit configured to receive input radiation and to generate, from the input radiation, a signal having a voltage magnitude; and

a piezo-electric transformer configured to increase the voltage magnitude of the signal to continuously generate a power supply signal capable of powering an electronic circuit while the input radiation is being received, wherein the piezo-electric transformer is continuously coupled to the electronic circuit that is powered by the power supply signal.

27. *The wireless communication device according to claim 26, wherein the receiver circuit includes an antenna arrangement configured to receive electromagnetic radiation and generate the signal therefrom, and wherein the electronic circuit includes a transponder that is operable using the power supply signal to generate an output signal that is transmitted by the antenna arrangement.*

28. *The wireless communication device according to claim 27, wherein the transponder is an oscillator configured to generate and transmit through the antenna arrangement the output signal in the form of encoded radiation that identifies the wireless communication device.*

29. *The wireless communication device according to claim 28, wherein the encoded radiation is unique to the oscillator.*

30. *The wireless communication device according to claim 27, wherein the transponder is operable to switch cyclically between a first period and a second period, the transponder generating the output signal during the first period and not generating the output signal during the second period.*

31. *The wireless communication device according to claim 27, wherein the transponder includes a pulsed transmitter in communication with the antenna arrangement, the pulsed transmitter generating the output signal in the form of bursts of signal that are emitted as radiation from the antenna arrangement.*

32. *The wireless communication device according to claim 31, wherein the bursts of signal are repeated at a rate that is unique to the wireless communication device.*

33. *The wireless communication device according to claim 27, wherein the transponder is configured to generate and transmit the output signal only when the power supply signal exceeds a threshold.*

34. *The wireless communication device according to claim 33, wherein the transponder is configured to prevent electrical flow of the power supply signal when the power supply signal is less than the threshold.*

35. *The wireless communication device according to claim 34, wherein the transponder includes a transistor configured to conduct the power supply signal for only part of a signal cycle when the power supply signal exceeds the threshold.*

36. *The wireless communication device according to claim 27, wherein the antenna arrangement includes a loop antenna coupled to the piezo-electric transformer, the loop antenna having an inductance that, in combination with a capacitance of the transformer, electrically resonates at an input radiation frequency corresponding with a vibrational mode of the transformer.*

37. *The wireless communication device according to claim 27, wherein the antenna arrangement is comprised of a single antenna, the device further comprising a rectifier circuit coupled to the antenna for generating the input signal, the transponder having a transmitter with a first transmitter output coupled to the output of the rectifier circuit and a second*

transmitter output coupled to the antenna, wherein during transmission of the output signal, the transmitter is configured to deliver a signal via the first transmitter output to reverse bias the rectifier circuit and then deliver the output signal via the second transmitter output to the antenna.

38. *The wireless communication device according to claim 37, wherein the power supply signal generated by the piezo-electric transformer is demodulated by a demodulator circuit and provided to the transmitter.*

39. *The wireless communication device according to claim 37, wherein the wireless communication device has a major surface and the antenna is sized to occupy a majority of the major surface of the device.*

40. *The wireless communication device according to claim 37, wherein the output signal delivered from the transmitter to the antenna is comprised of bursts of signal.*

41. *The wireless communication device according to claim 26, wherein the piezo-electric transformer is comprised of a ceramic bi-morph in the form of an elongate member supported at one end and free for vibration at an another end.*

42. *The wireless communication device according to claim 26, wherein the piezo-electric transformer is comprised of an array of one or more suspended silicon cantilevers, each cantilever incorporating a deposited film piezo-electric transducer operable to generate a signal in response to vibration of the cantilever, wherein the transducers are connected in series to add their signal voltages to provide the power supply signal.*

43. *The wireless communication device according to claim 42, further comprising an excitation transducer operable to be driven by a drive signal derived from the electromagnetic radiation received by the antenna arrangement for mechanically exciting the one or more cantilevers into vibration.*

44. *The wireless communication device according to claim 43, wherein the vibration is at a resonant frequency of the one or more cantilevers.*

45. *The wireless communication device according to claim 26, wherein the device is configured to attach to an item of merchandise and is operable in association with an interrogating source to provide a merchandise anti-theft system.*

46. *The wireless communication device according to claim 26, wherein the device is configured to attach to a person and provide a wearable identification device.*

47. *The wireless communication device according to claim 26, wherein the device is configured to attach to a person and provide a wearable data logger, wherein the wireless communication device further comprises a sensor and a memory coupled to the sensor for recording data sensed by the sensor.*

48. *The wireless communication device according to claim 47, wherein the electronic circuit includes a transponder that is configured to modulate an output signal to transmit data sensed by the sensor in response to received radiation.*

49. *The wireless communication device according to claim 48, wherein the sensor is an environmental sensor and the data logger is usable to monitor safety of an environment of a person wearing the data logger.*

50. *The wireless communication device according to claim 26 arranged in a system that further comprises an interrogator configured to emit the radiation received by the receiver circuit and receive an output signal transmitted by the wireless communication device.*

51. *The wireless communication device according to claim 26, wherein the receiver circuit incorporates first and second antennas for generating the signal having a voltage magnitude, the first antenna being adapted to respond to microwave radiation and the second antenna being adapted to respond to*

radiation having a carrier frequency corresponding to a resonant frequency of the piezo-electric transformer.

52. The wireless communication device according to claim 26, wherein the piezo-electric transformer comprises a silicon micromachined device having an array of resonant elements, each element incorporating an associated piezo-electric transducer operable to generate an element signal in response to vibration of its associated element, the transducers being connected in series to add their element signals to provide the output signal, and a driver operable to be driven by the input signal to stimulate the elements into vibration and thereby generate the power supply signal.

53. A method of wireless communication, comprising:
generating an interrogating signal in the form of electromagnetic radiation;

transmitting the interrogating signal to a wireless communication device that includes a receiver circuit, a piezo-electric transformer, and a transponder that is continuously coupled to the piezo-electric transformer, wherein the receiver circuit is configured to receive the radiation and generate a signal therefrom, wherein the piezo-electric transformer is configured to increase an electrical magnitude of the generated signal to continuously generate a power supply signal capable of powering the transponder while the radiation is being received, and wherein the transponder is operable to transmit an output signal;

receiving an output signal transmitted by the wireless communication device; and
processing the received output signal.

54. The method according to claim 53, wherein the piezo-electric transformer is comprised of an array of resonant elements connected in series, the method further comprising:
using the interrogating signal to vibrate a resonant element, wherein the vibrating resonant element produces a first output signal that causes the next resonant element in the series to vibrate and produce a second output signal having an electrical magnitude greater than the first output signal; and

generating the power supply signal from the output signal of the last resonant element in the series.

55. The method according to claim 53, further comprising:
distributing a plurality of the wireless communication devices along a path to a destination;

providing a vehicle with a direction sensitive interrogating source capable of generating the interrogating signal received by the receiver circuit of a wireless communication device;

interrogating the wireless communication devices from a source by emitting interrogating radiation to the wireless communication devices and receiving radiation therefrom, wherein the received radiation indicates a direction of the devices relative to the source;

determining a direction of the wireless communication devices relative to the source and hence determining the path;

moving the vehicle along the path; and

repeating the interrogating, determining, and moving the vehicle until the vehicle reaches the destination.

56. The method according to claim 53, further comprising attaching the wireless communication device to an item of merchandise and operating an interrogating source in association with the wireless communication device to provide a merchandise anti-theft system.

57. The method according to claim 53, further comprising attaching the wireless communication device to a person to provide a wearable identification device.

58. The method according to claim 53, further comprising attaching the wireless communication device to a person to provide a wearable data logger, wherein the method further comprises sensing environmental data with a sensor in the wireless communication device and recording the data sensed by the sensor in a memory coupled to the sensor.

59. The method according to claim 58, further comprising, in response to received radiation, modulating the output signal to transmit data sensed by the sensor.

60. The method according to claim 58, wherein the sensor is an environmental sensor, the method further comprising using the data logger to monitor safety of an environment of a person wearing the data logger.

61. The method according to claim 53, further comprising:
placing a plurality of the wireless communication devices at points along a lane;

emitting radiation from a vehicle to power the wireless communication devices and cause the devices to emit output signals;

receiving the output signal transmitted by the wireless communication devices; and

adjusting a direction of movement of the vehicle according to the received output signal.

62. A piezo-electric tag, comprising:

a receiver circuit configured to receive input radiation and generate a corresponding received signal;

a piezo-electric device configured to increase a voltage magnitude of the received signal to continuously generate a supply potential while the input radiation is being received; and

an electronic circuit powerable by the supply potential, wherein the electronic circuit is continuously coupled to the piezo-electric device to receive the supply potential.

63. The tag according to claim 62, wherein the piezo-electric device comprises a piezo-electric transformer incorporating mutually vibrationally coupled primary and secondary regions, the transformer being operable to be excited into vibration by the received signal at the primary region and to generate a corresponding output signal at the secondary region for use in generating the supply potential.

64. A tag according to claim 62, wherein the piezo-electric device comprises a piezo-electric bi-morph operable to be excited into vibration by the received signal and to generate a corresponding output signal for use in generating the supply potential.

65. The tag according to claim 62, wherein the piezo-electric device comprises a silicon micromachined device comprising an array of resonant elements, each element incorporating an associated piezo-electric transducer operable to generate an element signal in response to vibration of its associated element, the transducers being connected in series to add their element signals to provide an overall output from which the supply potential is generated, and a driver operable to be driven by the received signal for stimulating the elements into vibration and thereby generating the supply potential.

66. The tag according to claim 65, wherein the resonant elements are operable at resonance to generate the supply potential.

67. The tag according to claim 65, wherein the resonant elements are housed in an evacuated environment for increasing their resonance Q factor.

68. The tag according to claim 62, wherein the receiver circuit incorporates a demodulator for demodulating modulation components present in the received radiation to generate the received signal.

69. The tag according to claim 68, wherein the demodulator incorporates zero-bias Schottky diodes for demodulating the received radiation to generate the received signal.

70. The tag according to claim 68, wherein the demodulator incorporates transistors operable as synchronous demodulators for demodulating the received radiation to generate the received signal.

71. The tag according to claim 62, wherein the electronic circuit is operable to function in a class C mode for reducing tag power consumption.

72. The tag according to claim 62, wherein the receiver circuit incorporates first and second antennas for generating the received signal for exciting the vibrating means, the first antenna being adapted to respond to microwave radiation, and the second antenna being adapted to respond to radiation having a carrier frequency corresponding to a resonant frequency of the vibrating means.

73. The tag according to claim 62, wherein the receiver circuit incorporates at least one of a metallic film dipole antenna, a loop antenna and a patch antenna for at least one of receiving and emitting radiation.

74. The tag according to claim 62, wherein the electronic circuit comprises a transponder configured to emit output radiation from the tag, and wherein the supply potential that is continuously generated by the piezo-electric device is sufficient for the transponder to emit the output radiation.

75. The tag according to claim 74, wherein the piezo-electric device is operable to recover a clock component of Manchester bi-phase encoded radiation received at the tag, and wherein the transponder is operable to use the clock component to demodulate the encoded radiation to generate corresponding demodulated data for use in the tag.

76. The tag according to claim 74, wherein the tag incorporates two antennas, one antenna for use in generating the received signal, and the other antenna incorporated into the transponder for at least one of emitting and receiving radiation.

77. The tag according to claim 76, wherein the antennas are conductive metallic film dipole antennas.

78. The tag according to claim 62, the tag having a form of a block.

79. The tag according to claim 62, the tag having a form of a planar card.

80. The tag according to claim 79, wherein the card incorporates recesses for accommodating the receiver circuit, the piezo-electric device and the electronic circuit.

81. The tag according to claim 74, wherein the transponder is operable to receive input radiation to the tag and emit output radiation in response from the tag.

82. The tag according to claim 81, wherein the transponder is operable to modulate the output radiation with a signature code by which the tag is individually identified.

83. The tag according to claim 81, wherein the transponder incorporates a reflection amplifier for amplifying the input radiation to generate the output radiation.

84. The tag according to claim 81, wherein the transponder is operable in a pseudo-continuous mode and incorporates a delay line for delaying the output radiation relative to the input radiation, thereby counteracting spontaneous oscillation from arising within the transponder from feedback therein.

85. The tag according to claim 62, further comprising a metallic earthing plane for providing a common signal earth for the tag.

86. The tag according to claim 62, wherein the tag is configured for implantation into a biological system and is operable for at least one of monitoring and stimulating the biological system.

87. A wireless communication device, comprising:
a receiver circuit configured to receive input radiation and to generate a corresponding received signal; and
a piezo-electric transformer coupled to the receiver circuit, wherein the piezo-electric transformer is configured to increase a voltage magnitude of the received signal to generate a supply potential capable of powering an electronic circuit;
wherein the receiver circuit includes first and second antennas configured to generate the received signal, and wherein the first antenna is configured to respond to microwave radiation and the second antenna is configured to respond to radiation having a carrier frequency corresponding to a resonant frequency of the piezo-electric transformer.

88. The wireless communication device according to claim 87, wherein the piezo-electric transformer comprises primary and secondary regions that are mutually vibrationally coupled, wherein the primary region is configured to be excited into vibration by the received signal and the secondary region is configured to generate a corresponding output signal for generating the supply potential.

89. The wireless communication device according to claim 87, wherein the first antenna is coupled to a rectifier circuit having an output that is coupled to the primary region of the piezo-electric transformer, and wherein the second antenna is coupled to the primary region of the piezo-electric transformer.

90. The wireless communication device according to claim 88, wherein the second antenna is a coil antenna configured to resonate in conjunction with electrical capacitance of the piezo-electric transformer at the resonant frequency of the piezo-electric transformer.

91. A wireless communication device according to claim 87, wherein the piezo-electric transformer comprises a piezo-electric bi-morph configured to be excited into vibration by the received signal and to generate a corresponding output signal for generating the supply potential.

92. A wireless communication device according to claim 87, wherein the piezo-electric transformer comprises a silicon micromachined device that includes:

an array of one or more resonant elements, wherein each resonant element comprises an associated piezo-electric transducer configured to generate an element signal in response to vibration of the resonant element, and wherein the piezo-electric transducers of the one or more resonant elements are connected in series such that their element signals combine to provide an overall output from which the supply potential is generated; and
an excitation transducer configured to be driven by the received signal to stimulate the one or more resonant elements into vibration and thereby generate the supply potential.

93. A wireless communication device according to claim 87, wherein the electronic circuit comprises a transponder powerable by the supply potential and configured to emit output radiation.

UNITED STATES PATENT AND TRADEMARK OFFICE
CERTIFICATE OF CORRECTION

PATENT NO. : RE42,449 E
APPLICATION NO. : 11/804715
DATED : June 14, 2011
INVENTOR(S) : Forster

Page 1 of 1

It is certified that error appears in the above-identified patent and that said Letters Patent is hereby corrected as shown below:

Column 1, lines 10-13, delete “This application is a 371 national stage entry of PCT/GB00/02944 dated Jul. 31, 2000, which claims priority to United Kingdom application 9917856.8 dated Jul. 29, 1999.” and insert

-- PRIORITY DATA

This application is a 371 national stage entry of PCT/GB00/02944 dated Jul. 31, 2000, which claims priority to United Kingdom application 9917856.8 dated Jul. 29, 1999. --.

Signed and Sealed this
Eleventh Day of October, 2011



David J. Kappos
Director of the United States Patent and Trademark Office