



US00RE42272E

(19) **United States**  
(12) **Reissued Patent**  
**Zakhor et al.**

(10) **Patent Number:** **US RE42,272 E**  
(45) **Date of Reissued Patent:** **Apr. 5, 2011**

(54) **DICTIONARY GENERATION METHOD FOR VIDEO AND IMAGE COMPRESSION**

(75) Inventors: **Avideh Zakhor**, Berkeley, CA (US);  
**Phillippe Schmid**, Chexbres (CH)

(73) Assignee: **Videopression LLC**, Wilmington, DE (US)

(21) Appl. No.: **12/034,912**

(22) Filed: **Feb. 21, 2008**

**Related U.S. Patent Documents**

Reissue of:

(64) Patent No.: **7,003,039**  
Issued: **Feb. 21, 2006**  
Appl. No.: **09/909,140**  
Filed: **Jul. 18, 2001**

(51) **Int. Cl.**  
**H04N 7/12** (2006.01)  
**H04N 11/02** (2006.01)

(52) **U.S. Cl.** ..... **375/240.22; 375/240.16**

(58) **Field of Classification Search** ..... **375/240.01–240.06, 240.12–240.16, 240.22, 240.26**  
See application file for complete search history.

(56) **References Cited**

**U.S. PATENT DOCUMENTS**

5,255,342	A	10/1993	Nitta	
5,444,488	A	8/1995	Goubault	
5,457,495	A *	10/1995	Hartung	375/240.14
5,699,121	A *	12/1997	Zakhor et al.	375/240.17
5,764,921	A	6/1998	Banham	
5,859,932	A *	1/1999	Etoh	382/253
6,754,624	B2	6/2004	Choy	
2001/0028683	A1	10/2001	Bottreau et al.	

**OTHER PUBLICATIONS**

R. Neff et al.; “Very Low Bit Rate coding Using Matching Pursuit”; Visual communications and Image Processing 1994; A.K. Katsaggelos, Ed., Proceedings of the SPIE vol. 2308, 1994, pp. 47–60.

R. Neff et al.; “Matching Pursuit Video coding at Very Low Bit Rates”; Proceeding of the IEEE Data Compression Conference; 1995, pp. 411–420.

R. Neff et al.; “Very Low Bit-Rate Video coding Based on Matching Pursuits”; IEEE Transactions on Circuits and Systems for Video Technology, vol. 7(1); 1997; pp. 158–171.

O. Al-Shaykh et al.; “Video compression Using Matching Pursuits”; IEEE Transactions on Circuits and Systems for Video Technology vol. 9(1); 1999; pp. 123–143.

R. Neff et al.; “Dictionary Approximation for Matching Pursuit Video Coding”; Proceedings of the International Conference on Image Processing (ICIP) 2000; pp. 828–831.

Y. Linde et al.; “An Algorithm for Vector Quantizer Design”; IEEE Transactions on Communications vol. 28(1);1980; pp. 85–95.

(Continued)

\* cited by examiner

*Primary Examiner*—David Czekaj

(74) *Attorney, Agent, or Firm*—Stolowitz Ford Cowger LLP

(57) **ABSTRACT**

This invention relates to the creation of dictionary functions for the encoding of video signals using matching pursuit compression techniques. After an initial set of reference dictionary images is chosen, training video sequences are selected, and motion residuals are calculated. High energy portions of the residual images are extracted and stored when they match selection criteria with the reference dictionary. An energy threshold is used to limit the number of video signal “atoms” encoded for each frame, thus avoiding the encoding of noise. A new dictionary is then synthesized from the stored portions of the image residuals and the original reference dictionary. The process can then be repeated using the synthesized dictionary as the new reference dictionary. This achieves low bit rate signals with a higher signal-to-noise ratio than have been previously achieved.

**20 Claims, 8 Drawing Sheets**

## OTHER PUBLICATIONS

K. Zegar et al.; "Globally Optimal Vector Quantizer Design by Stochastic Relaxation"; IEEE Transactions on Signal Processing vol. 40(2); 1992; pp. 310–322.

K. Rose et al.; "Vector Quantization by Deterministic Annealing"; IEEE Transactions on Information Theory vol. 38(4); 1992; pp. 1249–1257.

S. Mallat et al.; "Matching Pursuits with Time–Frequency Dictionaries"; IEEE Transactions on Signal Processing vol. 41(12); 1995; pp. 3397–3415.

O. Al-Shaykh et al.; "Video Sequence Compression"; Chapter in the Digital Signal Processing Handbook, edited by V.K. Madisetti and D.B. Williams; CRC/IEEE Press. 1998; pp. 55–1–55–19.

N.B. Karayiannis et al.; "Fuzzy Algorithms for Learning Vector Quantization"; IEEE transactions on Neural Networks; vol. 7(5); 1996; pp. 1196–1211.

B.A. Olshausen et al.; Emergence of simple Cell Receptive Field Properties by Learning a Sparse Code for natural Images; Nature vol. 381; 1996; pp. 607–609 UK.

D. Redmill et al.; "Video Coding Using a Fast Non–Separable Matching Pursuits Algorithm"; Proceedings of the ICIP vol. 1; 1998; pp. 669–773.

C. De Vleeschouwer et al.; "New Dictionaries for Matching Pursuits video Coding"; Proceedings of the ICIP vol. 1; 1998; pp. 764–768.

Y.T. Chou et al.; "Very Low Bit Video Coding Based on Gain Shape VQ and Matching Pursuits"; Proceedings of the ICIP; 1999; pp. 76–80.

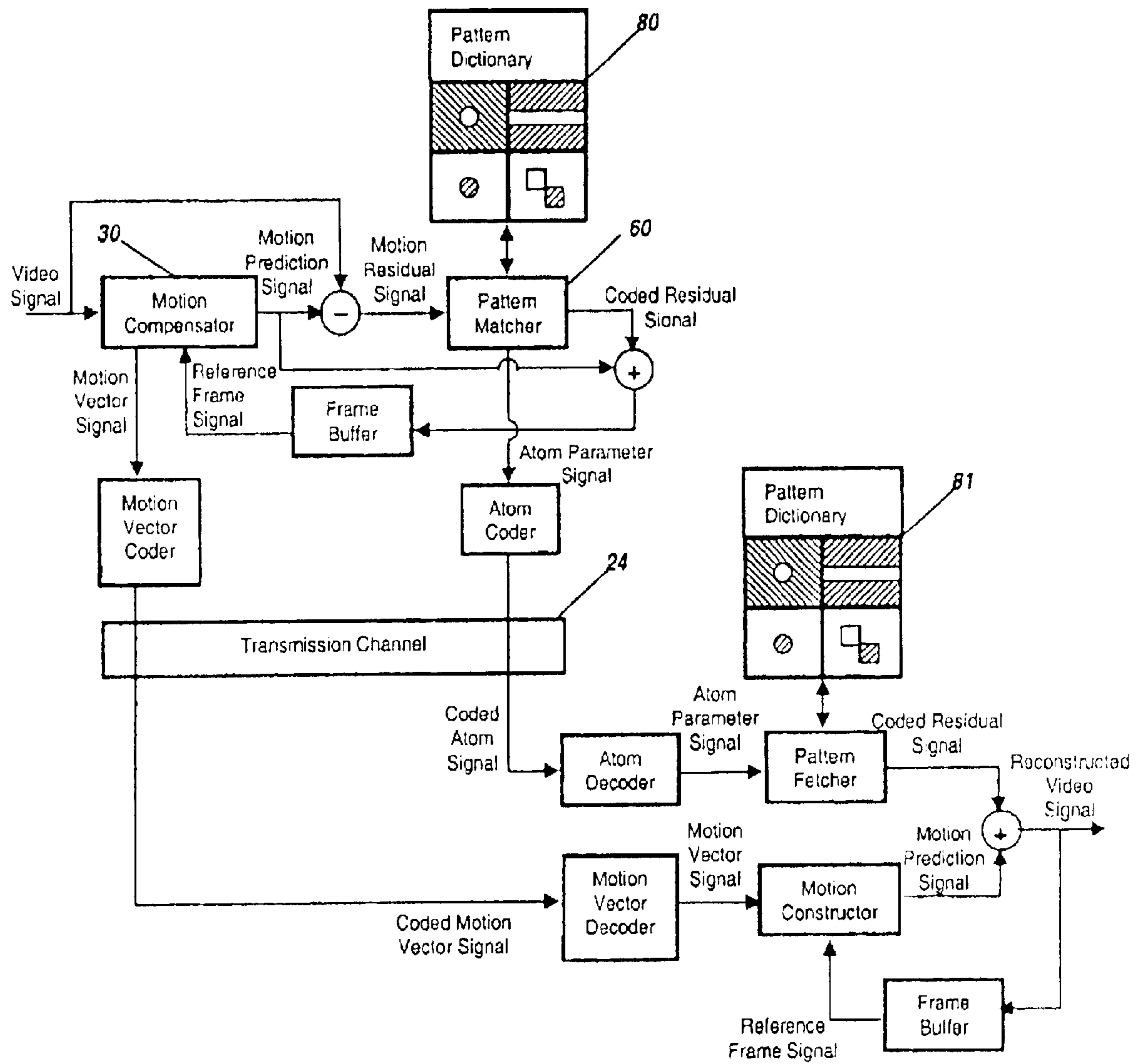

Figure 1

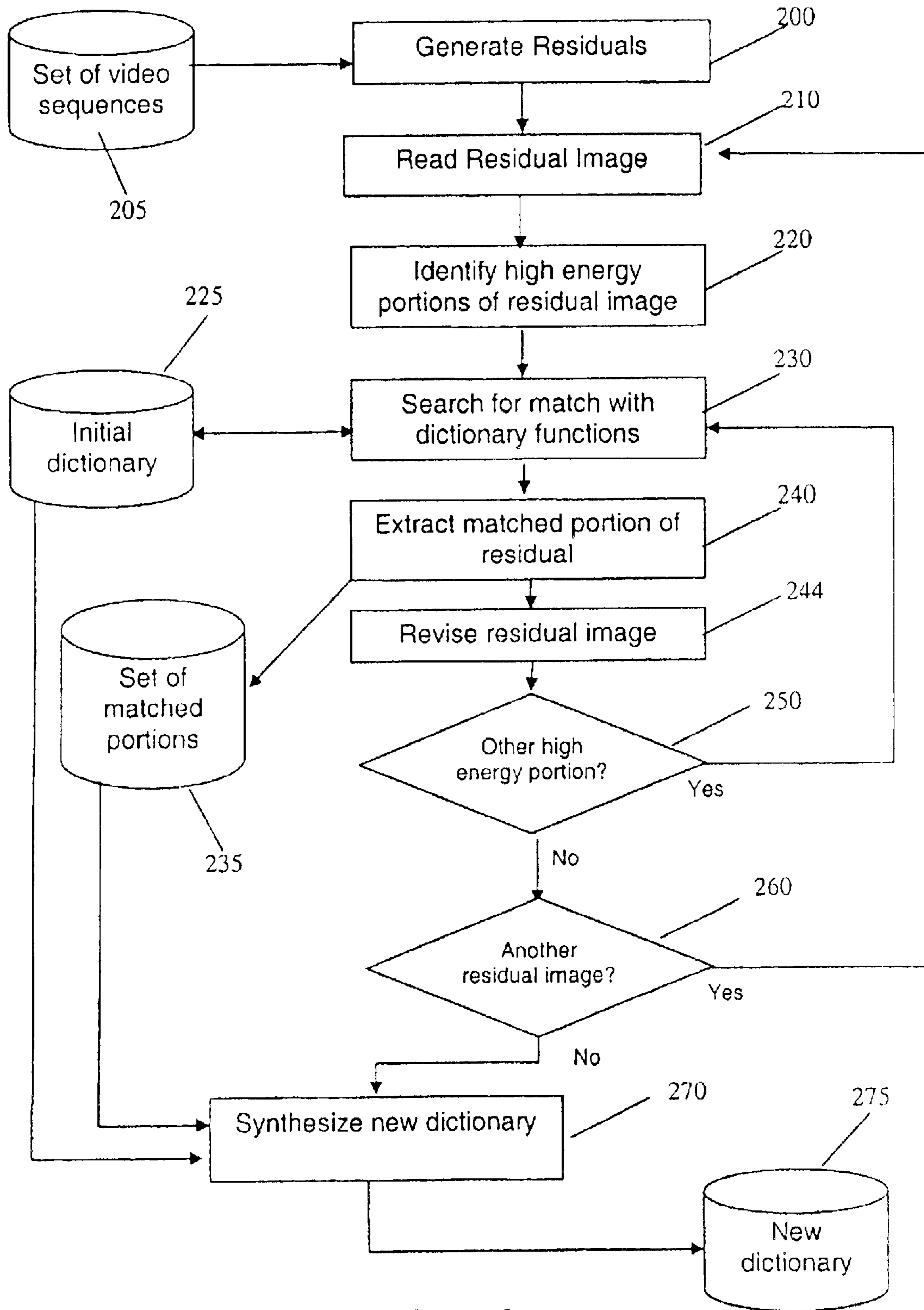

Figure 2



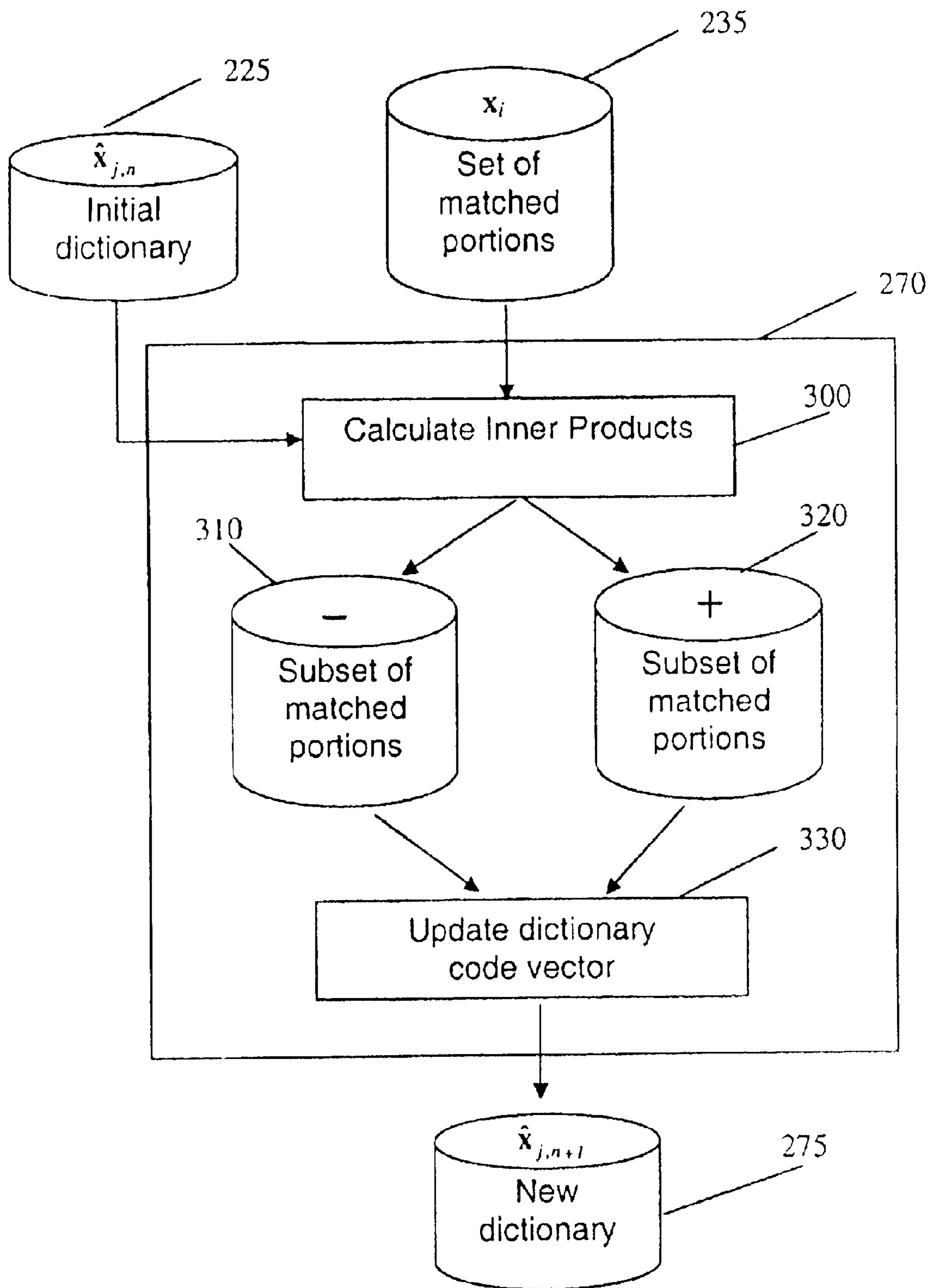

Figure 3

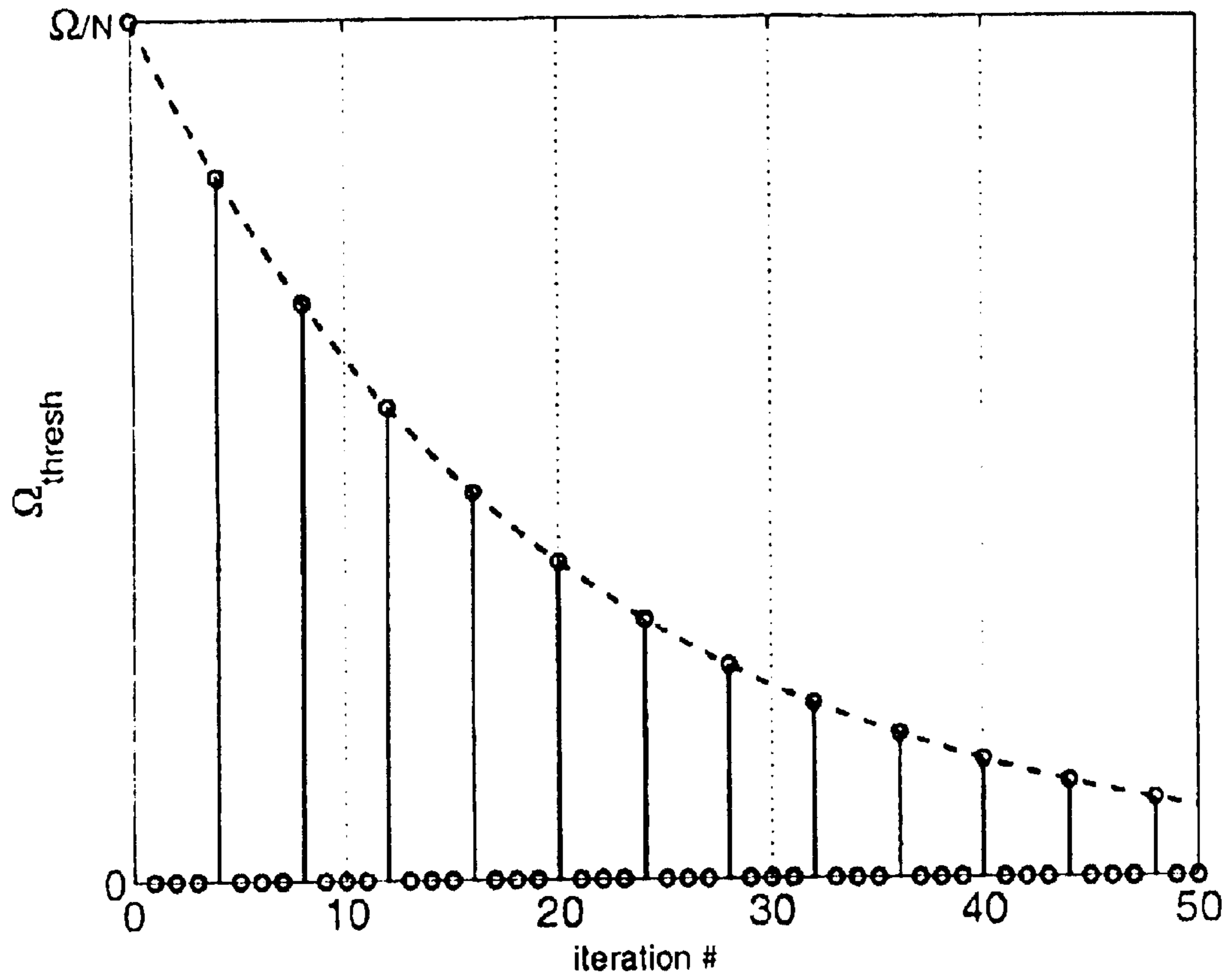

Figure 4

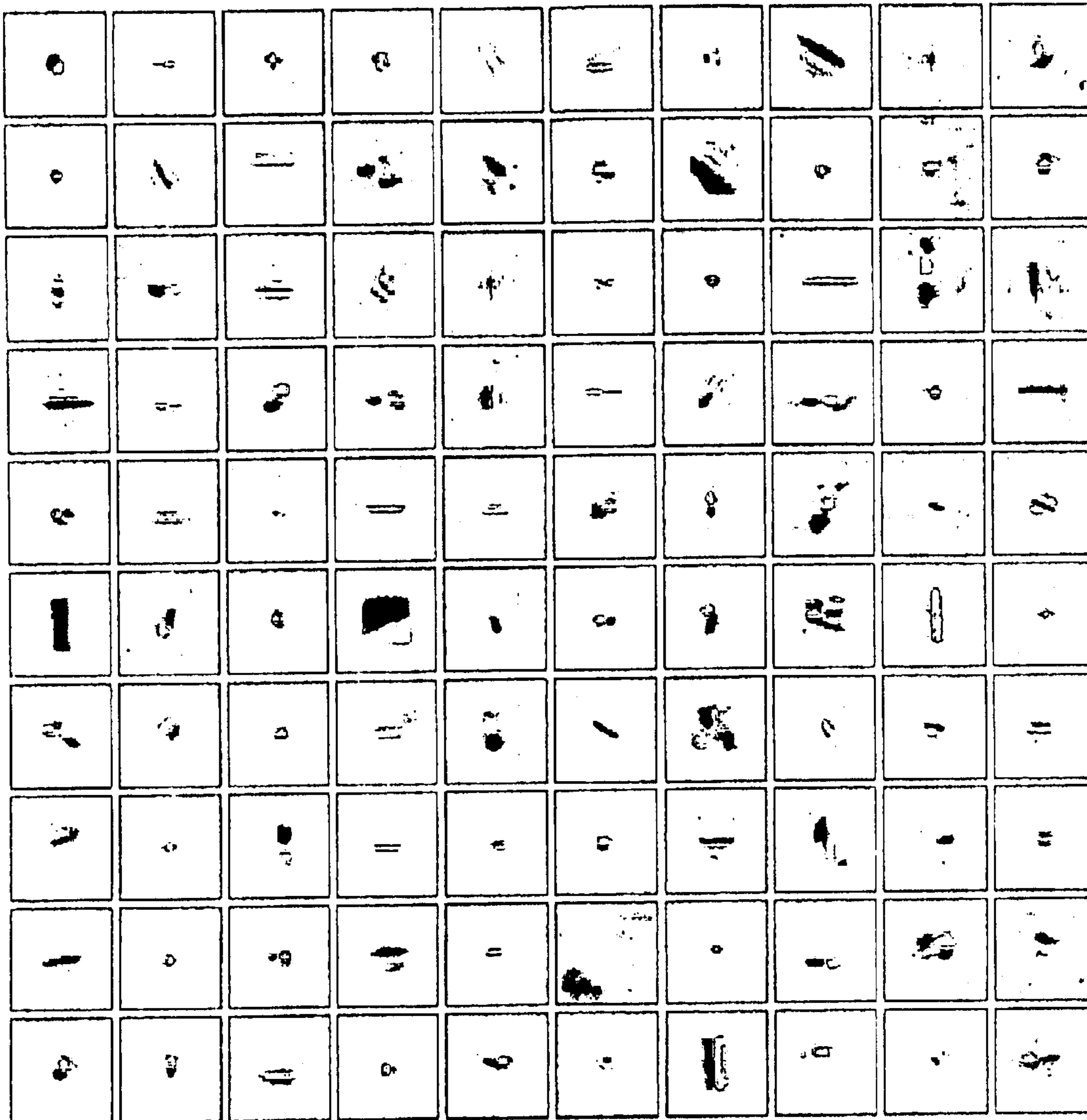

Figure 5

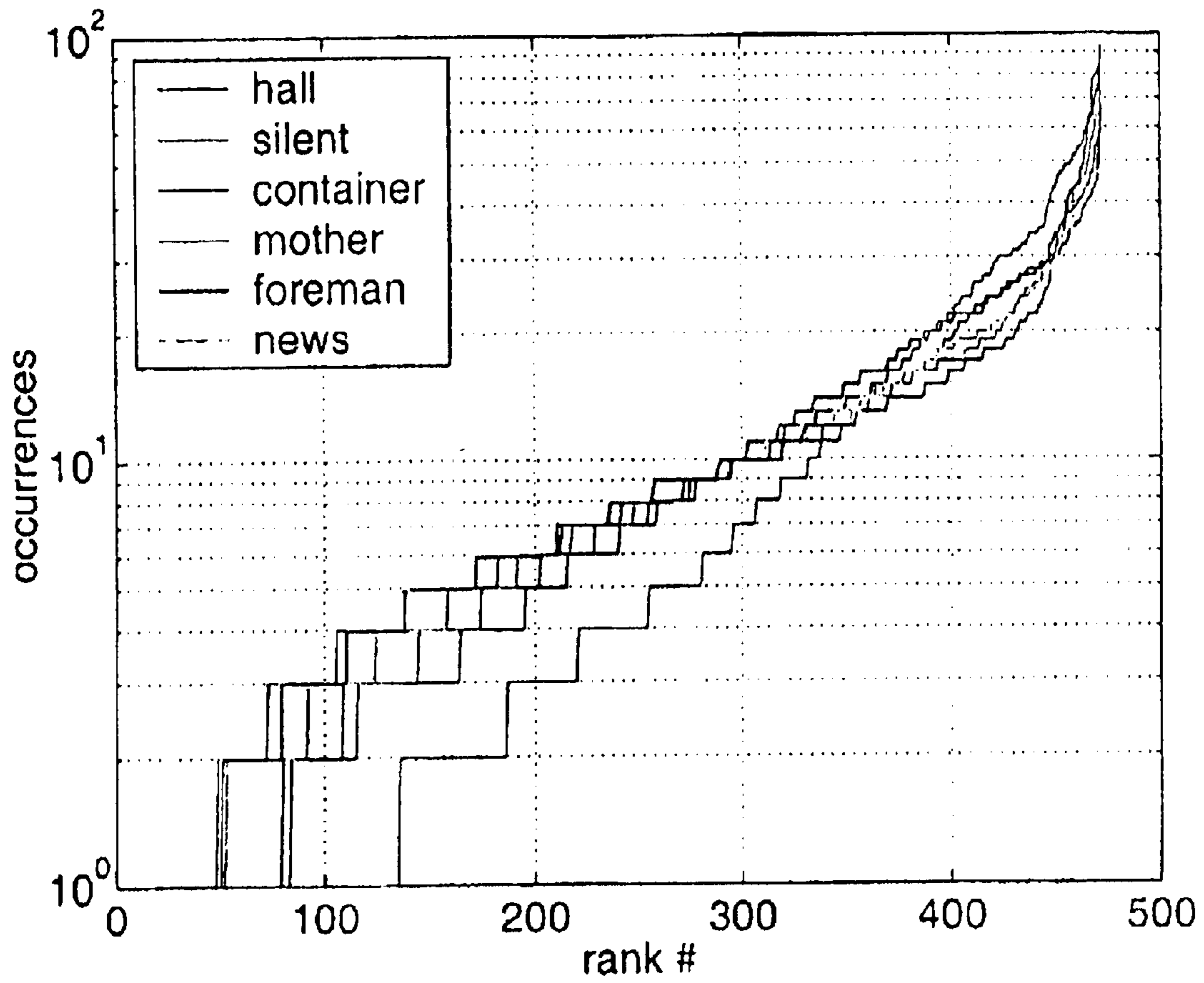

Figure 6



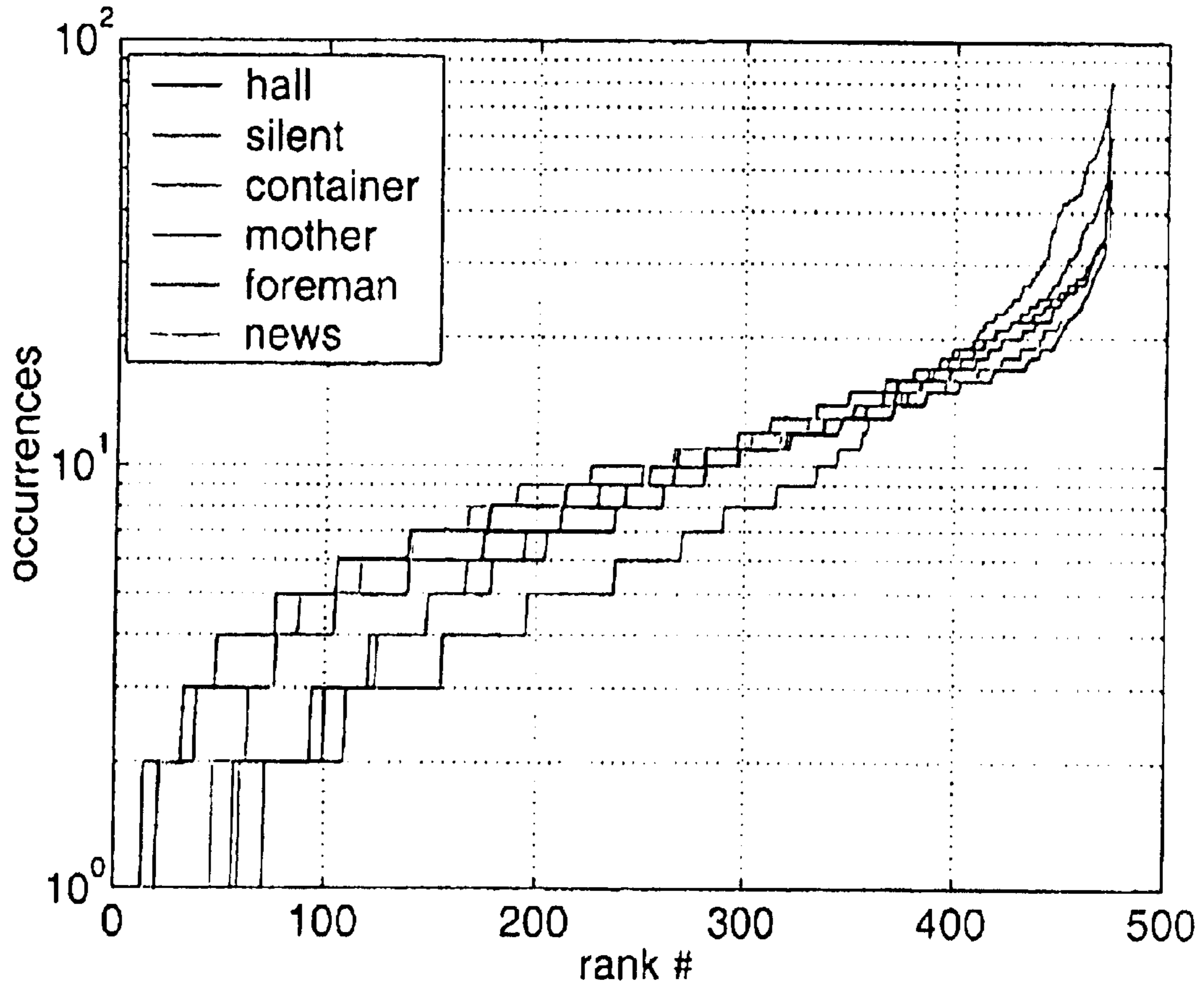

Figure 7

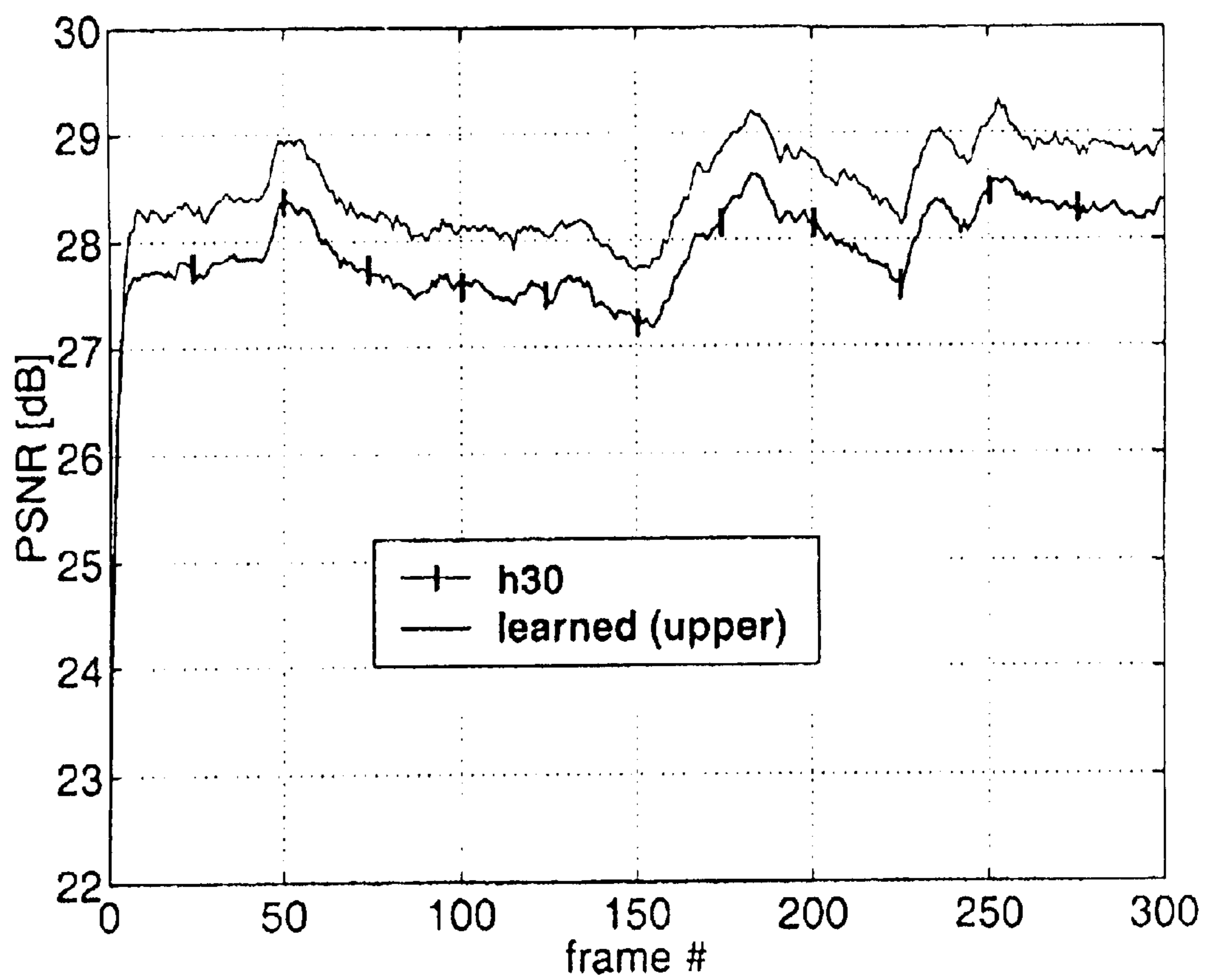

Figure 8



## DICTIONARY GENERATION METHOD FOR VIDEO AND IMAGE COMPRESSION

**Matter enclosed in heavy brackets [ ] appears in the original patent but forms no part of this reissue specification; matter printed in italics indicates the additions made by reissue.**

### FIELD OF THE INVENTION

This invention relates to the creation of dictionary functions for the encoding of video sequences in matching pursuit video compression systems. More particularly, this invention presents a method for generating a dictionary for encoding video sequences from a set of patterns extracted, or learned from training input video sequences. When the learned dictionary is used to encode video sequences, it produces low bit rate signals with a higher signal-to-noise ratio.

### BACKGROUND OF THE INVENTION

Recent developments in computer networks, and the demand for the transmission of video information over the Internet, have inspired many innovations in video signal encoding for compressed transmission. Of the highest priority is the ability to produce a signal at the destination which is the best match to the original as possible, i.e. the one with the largest signal-to-noise ratio and represented by the smallest number of bits.

To this end, several decomposition techniques have been developed and will be known to those skilled in the art. In these techniques, once a particular frame has already been transmitted, the information required to transmit the succeeding frame can be minimized if the new frame is divided into a motion vector signal, characterizing how a set of pixels will translate intact from the first frame to the succeeding frame, and a residual signal, which describes the remaining difference between the two frames. By transmitting only the motion vector and the residual, a certain amount of data compression is achieved.

The residual itself can be transmitted even more efficiently if both ends of the transmission line contain pattern dictionaries, also called libraries, of primitive image elements, or functions. By matching the residual (or portions thereof) to patterns in the dictionary, the receiver (which also contains a copy of the dictionary) can look up the required element when only the identifying code for the dictionary element is transmitted, further reducing the amount of data that needs to be transmitted to reconstruct the image. This is a technique called Matching Pursuit (MP). This was originally applied to the compression of still images, as has been discussed by S. Mallet and Z. Zhang, "Matching pursuits with time-frequency dictionaries", in IEEE Transactions on Signal Processing Vol. 41(12), pp. 3397-3415 (1995), and has been applied to video processing as well, as described by R. Neff, A. Zakhor, and M. Vetterli, "Very low bit rate video coding using matching pursuit", in Proceedings of the SPIE Vol. 2308, pp 47-60 (1994), and A. Zakhor and R. Neff, in U.S. Pat. No. 5,669,121 "Method and Apparatus for Compression of Low Bit Rate Video Signals".

The creation of dictionary functions which are well matched to describe practical video residuals is therefore of paramount importance for high fidelity video transmission. Simple sets, such as Gabor functions, can be used with good results. However, there is a need to provide the best possible image fidelity with the most efficient dictionary, and there is therefore a need to improve on the compression efficiency achieved using the Gabor functions.

## SUMMARY OF THE INVENTION

In this invention, we provide a method for creating a dictionary for matching pursuit video encoding not from an abstract set of patterns, but derived (or learned) from a set of training video sequences. In particular, an algorithm similar to those used in vector quantization (VQ) is used to adapt and update an initial trial dictionary to best match the residuals found in the set of training images. We have found that using standard video benchmarks as training signals to synthesize a new dictionary can lead to a general improvement in video signal-to-noise ratios of 0.2-0.7 dB when compared to the results from a simple Gabor set.

Vector quantization is basically a two step iterative procedure where a dictionary of vectors is learned from input vectors by splitting them into partitions according to a minimum distortion measure, and re-computing the dictionary vectors (also called code vectors) as the centroids of the different partitions. This is not a new topic, as can be seen in Y. Linde, A. Buzo, and R. M. Gray, "An algorithm for vector quantizer design", in IEEE Transactions on Communications Vol. 28(1), pp 84-95 (January, 1980).

However, to apply these algorithms to the problem of video compression, the basic algorithms must be adapted. Vector quantization typically divides an image into tiles of fixed pixel sizes, and looks for the best match in the dictionary for each of the tiles. Previously published variations have included stochastic relaxation methods (K. Zegar, J. Vaisey, and A. Gersho, "Globally optimal vector quantizer design by stochastic relaxation", in IEEE Transactions on Signal Processing Vol 40(2), pp 310-322 (1992)), the use of a deterministic annealing approach (K. Rose, E. Gurewitz, and G. C. Fox, "Vector quantization by deterministic annealing", in IEEE Transactions on Information Theory Vol. 38(4) pp 1249-1257, (1992)), and fuzzy sets (N. B. Karayiannis and P. I. Pai, "Fuzzy algorithms for learning vector quantization", in IEEE Transactions on Neural Networks Vol 7(5) pp 1196-1211 (1996)). All have been functional to some degree, but are time consuming and have high computational overhead.

In our invention, we do not use a fixed tiling for coding of residual image pixels, but instead identify sets of pixels for comparison to the dictionary in which both the center of the set of pixels and the dimension can vary. The selection of the portions of the image to be evaluated are based on the measure "energy", present in the image pixels. Our modification to vector quantization also introduces a time-decreasing threshold to decide which partitions should stay in the learning process, and which should be replaced. New partitions are obtained by splitting large partitions into two subsets. We have found this approach to be fast, and leads to near optimal results.

Although we have applied this method to encoding video sequences, the techniques of our invention can also be applied to the compression of still images, and to other compression techniques that use dictionaries but that are not classically defined as matching pursuit compression schemes.

### BRIEF DESCRIPTION OF THE DRAWINGS

FIG. 1 shows a block diagram of a matching pursuit video system.

FIG. 2 shows a flow chart of dictionary creation according to the method of the present invention.

FIG. 3 shows a flow chart of dictionary synthesis according to the method of the present invention.



FIG. 4 illustrates variation in the partition size relaxation function used in one embodiment of the invention.

FIG. 5 shows a representation of a portion of the functions in the learned dictionary generated according to one embodiment of the invention.

FIG. 6 illustrates the ranked usage of the Gabor functions in matching pursuit video encoding.

FIG. 7 illustrates the ranked usage of the learned dictionaries of one embodiment of this invention in matching pursuit video encoding.

FIG. 8 illustrates the signal to noise ratio for encoding the test sequence Mobile for a learned dictionary according to one embodiment of the invention and for the use of a Gabor set.

### DETAILED DESCRIPTION OF THE INVENTION

This invention relates to the creation of dictionaries for compressing video, and in particular matching pursuit (MP) video encoding systems. An illustration of an MP video compression scheme is shown in FIG. 1. Motion compensation is identified and encoded by the motion compensator 30, and the residual signal is then "matched" by a pattern matcher 60 to one of several functions in the pattern dictionary 80. This residual signal is then coded as an "atom" and sent to the receiver, along with the motion vector, through the transmission channel 24. Upon receipt, the "atom" is decoded and the matched pattern is retrieved from a local copy of the pattern library 81. The final video signal is recreated by recombining the decoded motion vector and the retrieved library pattern.

An example of a dictionary for this kind of video compression system is the set of Gabor functions. These have been described by C. DeVleeschouwer and B. Macq, "New Dictionaries for matching pursuits video coding", in Proceedings of the ICIP '98 (1998) and by R. Neff and A. Zakhor, "Dictionary approximation for patching pursuit video coding", Proceedings of the ICIP 2000 (2000). There are a number of drawbacks to the Gabor functions, however, notably that the heuristics are not systematic, and atoms from Gabor functions tend to introduce small oscillations in the reconstructed signal.

In this invention, we develop a method to generate a dictionary using motion compensated residuals obtained from a set of training sequences, and adapt the learning scheme to the characteristics of matching pursuit. The initial dictionary can be a set of Gabor functions, or other functions derived from other sources.

The overall sequence of operations is illustrated in FIG. 2. After an initial reference dictionary 225 and a set of training images 205 have been selected, a residual for one of the images is generated in step 200. Step 210 loads the residual image. The high energy portions (i.e. portions where the changes are greater than a predetermined threshold) are identified in step 220. Regions of varying dimension, centered around the high energy portions of the residual are compared to elements in the reference dictionary 225 for the best match in step 230. When a match is found, the next step 240 extracts the matched portion of the residual and a copy of that portion of the residual, called a pattern, is stored as an element in a set of collected patterns 235.

If the extraction process has not automatically removed the high energy residual, step 244 explicitly does so. The remaining portion of the residual is then evaluated in step 250 for other high energy portions, and these again compared to the reference dictionary by repeating steps 230-250 until all high energy portions are matched. Once the selected residual has been exhausted, step 260 tests whether there are other residual images in the training sequence to examine, and if there are steps 210 through 260 are repeated.

Then, the new dictionary 275 is synthesized in step 270 from the initial dictionary 225 and the set of collected patterns 235 using mathematical algorithms updating dictionary code vectors. The process can then be repeated again for further refinement with the new, synthesized dictionary 275 replacing the original reference dictionary 225.

Details from the synthesizing step are illustrated in FIG. 3. A set of inner products between the collected patterns 235 and the elements of the initial dictionary 225 are calculated in step 300, and the elements of the collected pattern set 235 are divided into two sets, 310 and 320, depending on whether the sign of the inner product is positive or negative. An updated code vector for the new dictionary is then calculated from these two subsets in step 330 using a calculation weighted by the energy of the pattern. The updated code vector is typically normalized and then entered into the new dictionary 275.

In more detail, this learning scheme is similar to algorithms developed for vector quantization (VQ). VQ is an iterative algorithm that learns a given number of vectors, called hereafter code-vectors, from a set of input vectors, also called patterns, according to a pre-defined distortion measure.

Each iteration has two fundamental processing steps:

1. Partition the set of patterns.
2. Update the code-vectors in order to minimize the total distortion in each partition.

The algorithm ends when a predefined stopping criterion, such as a maximum allowed overall distortion, is met.

MP uses the inner product to match the different dictionary functions to the residuals and to select the different atoms used to encode the original signal. We have therefore chosen to use an inner product based distortion measure in our invention, since this metric will later define how well a learned dictionary function matches a residual. Let  $S \subset R^k$  be a set of  $M$  normalized training patterns of dimension  $k$ ,  $X = \{1, \dots, N\}$  the set of all code-vector indices, and  $n$  the iteration number. The energy  $\omega_i$  of the  $i^{\text{th}}$  pattern is computed before normalization for later use during the code-vector updating step.

We define the following distortion measure between a normalized pattern  $x_i \in S$  and the  $j^{\text{th}}$  normalized code-vector  $\hat{x}_{j,n}$ :

$$d_{\langle \cdot, \cdot \rangle}(x_i, \hat{x}_{j,n}) = 1 - |\langle x_i, \hat{x}_{j,n} \rangle| \quad [1]$$

where  $\langle \cdot, \cdot \rangle$  is the inner product. The distortion is equal to 1 when  $x_i$  and  $\hat{x}_{j,n}$  are orthogonal and equal to 0 when they are identical.

A partition  $S_{j,n}$  is a set of patterns having minimum distortion with respect to a given code-vector  $\hat{x}_{j,n}$ :

$$S_{j,n} = \{x_i \in S \mid d_{\langle \cdot, \cdot \rangle}(x_i, \hat{x}_{j,n}) \leq d_{\langle \cdot, \cdot \rangle}(x_i, \hat{x}_{l,n}), \forall l \in X\} \quad [2]$$

and

$$S = \bigcup_{j \in X} S_{j,n} \quad [3]$$

$$S_{j,n} \cap S_{l,n} = \emptyset \quad [4]$$

$\forall j \neq l$  and with  $j, l \in X$



## 5

The updated code-vector  $\hat{x}_{j,n} \in \mathbb{R}^k$  is obtained by minimizing the total distortion  $\delta_{j,n}$  in  $S_{j,n}$ :

$$\delta_{j,n} \equiv \sum_{x_i \in S_{j,n}} d_{\langle \cdot, \cdot \rangle}(x_i, \hat{x}_{j,n}) \leq \sum_{x_i \in S_{j,n}} d_{\langle \cdot, \cdot \rangle}(x_i, x) \forall x \in \mathbb{R}^k \quad [5]$$

Since both  $x_i$  and  $\hat{x}_{j,n}$  are normalized, the following  $L_2$ -norm distortion measure can be used instead of Equation [1]:

$$\begin{aligned} d_{L_2}(x_i, \hat{x}_{j,n}) &= \|\hat{x}_{j,n} - x_i\|^2 \\ &= (\hat{x}_{j,n} - x_i) \cdot (\hat{x}_{j,n} - x_i)^T \\ &= 2 - 2\hat{x}_{j,n} \cdot x_i^T \\ &= 2(1 - \langle x_i, \hat{x}_{j,n} \rangle) \end{aligned} \quad [6]$$

provided all inner products are positive.

To achieve this, we let each pattern have two equivalent versions: the original and its negative, i.e.  $x_i$  and  $-x_i$ . This is possible because Equation [1] uses the absolute value of the inner product. We then define  $S_{j,n}^{(+)}$  and  $S_{j,n}^{(-)}$  as sets of patterns in  $S_{j,n}$  having respectively positive and negative inner product with  $\hat{x}_{j,n}$ :

$$S_{j,n}^{(+)} \cup S_{j,n}^{(-)} = S_{j,n} \quad [7]$$

$$S_{j,n}^{(+)} \cap S_{j,n}^{(-)} = \emptyset \quad [8]$$

Once both subsets are computed, we can use equation [6] instead of [1] by taking the negative value of the inner product for each pattern in  $S_{j,n}^{(-)}$ . Those skilled in the art will realize that Lagrange multipliers can be used for the minimization of equation [5] with the distortion measure defined in Equation [6], and this leads to the following weighted average update equation:

$$\hat{x}_{j,n+1} = \frac{\sum_{x_i \in S_{j,n}^{(+)}} \omega_i x_i}{\sum_{x_i \in S_{j,n}^{(+)}} \omega_i} - \frac{\sum_{x_i \in S_{j,n}^{(-)}} \omega_i x_i}{\sum_{x_i \in S_{j,n}^{(-)}} \omega_i} \quad [9]$$

This is the algorithm used in the synthesizing step 330 of FIG. 3. More weight is given to high energy patterns in Equation [9] since it is essential to first encode high energy structures present in the motion compensated error. The code-vectors are normalized after being updated.

The algorithm described so far usually converges to a local minimum. In our invention, we put a constraint on the partition size according to a monotonically decreasing function of the iteration number. Partitions smaller than the value given by this function are eliminated. In order to keep the same number of centroids, a randomly selected partition is split into two, with larger partitions being more likely to be selected than smaller ones. The following exponential threshold function is used in our simulations:

$$\Omega_{\text{thresh}} = \frac{\Omega}{N} \exp\left\{-\frac{M}{M_0}\right\} \quad [10]$$

where  $M$  is the iteration number,  $M_0$  is a constant scalar that controls the time necessary to converge to the final solution,  $N$  is the number of code-vectors, and

## 6

$$\Omega = \sum_{i=1}^n \omega_i \quad [11]$$

is the weighted size of the pattern space.

In this invention,  $\Omega$  need not be used in every iteration, and it can be beneficial to set the value of  $\Omega$  to 0 for many of the iteration steps. We have typically used the total number of iterations  $M$  to be 20, and use a non zero value for  $\Omega$  in every fourth iteration. This is illustrated in FIG. 4. While this approach is of low complexity, it has shown to be robust, and to lead to near-optimal results.

The extraction of training patterns from the motion residuals is an important aspect of the invention. The entire residual cannot be learned by our system since the high energy content is sparsely distributed. Only regions in the residual where one or several dictionary functions are matched are taken into account. These regions are typically designated to be square with varying dimensions that encompass the entire high energy region, but other dimensions could be used as well. The patterns used to learn new functions are extracted from a set of training sequences encoded with an initial reference dictionary. One example of a set that can be used for the reference dictionary is the set of Gabor functions. Each time a high energy portion of a residual image is matched to a dictionary function, the underlying pattern is extracted. A square window with a fixed size, centered on the matched region, can be used, although windows of other geometries will be apparent to those skilled in the art. Using this approach, only high energy regions of the residual are separated to become patterns used for the training.

Finally, once a new dictionary has been learned, the training sequences are encoded with this new dictionary in order to produce usage statistics. These statistics are then used to compute the Huffman codes necessary to encode the atom parameters for the test sequences.

## DESCRIPTION OF A REDUCTION TO PRACTICE

We have implemented software written in ANSI C on a Silicon Graphics Onyx computer to test and demonstrate the capabilities of this invention. To begin, a dictionary must be chosen as an initial reference dictionary. We chose the dictionary h30, as previously described by R. Neff and A. Zakhor, in "Dictionary approximation for matching pursuits video coding", published in the Proceedings of the ICIP 2000. This dictionary contains 400 separable Gabor functions and 72 non-separable Gabor functions. The number of functions learned in our simulations is therefore always 472.

Three dictionaries are learned, each one supporting a different number of pixels. The regions of support in this case were chosen to be  $9 \times 9$ ,  $17 \times 17$ , and  $35 \times 35$ . In order to obtain a large training set, we collected 17 high motion video sequences of 30 frames each from outside the standard MPEG sequences. Many short sequences were used to allow as many different sequences as possible to be part of the training set while maintaining the total number of training patterns at a reasonable level, in our case around 120,000. The MPEG sequences are kept for the test phase, because they can be easily compared to other techniques for which simulation results are available in the literature.

We also apply a threshold to the energy of the residual to control the bit-rate during learning. The threshold is set empirically, in order to match as precisely as possible the



bit-rates suggested for the different MPEG sequences and avoid encoding noise for low energy regions. Finally, usage statistics are used to reduce the size of the learned dictionary from  $3 \times 472 = 1416$  down to 472, the number of patterns in the initial dictionary.

A subset of the learned dictionary is shown in FIG. 5. After statistical pruning, it contains 116 functions from the  $35 \times 35$  dictionary (24.47%), 169 functions from the  $17 \times 17$  dictionary (35.65%), and 189 functions from the  $9 \times 9$  dictionary (39.88%). Most of these functions have therefore a small region of support. In general, they are well centered, oriented, limited in size, and modulated. We therefore expect that the learned functions can be easily and efficiently approximated with functions of low complexity for fast implementation. The fact that the learned functions have a coherent structure is a very good result, given that learning schemes providing functions of such a "quality" are difficult to establish, in computer vision applications in general.

The ranked usage statistics of all functions in h30 and in the learned dictionary are plotted in FIG. 6 and FIG. 7. These distributions show that the learned dictionary gives almost equal importance to all functions. In that sense, our learning scheme is very efficient.

The learned dictionary is evaluated with 6 QCIF test sequences: Foreman, Coast, Table tennis, Container, Mobile, and Stefan. In all simulations, in order to guarantee similar bit-rate between h30 and our newly designed dictionary, we use the bit trace corresponding to h30 runs to control the bit-rate of our designed dictionary, even though this could potentially lower its performance. A PSNR plot for the sequence Mobile is shown in FIG. 8, and the performance results are summarized in TABLE I. These results show that learning new dictionaries improves PSNR performances especially at higher bit-rates, since at low bit-rates most of the bit budget is spent on the motion vectors.

TABLE I

Signal to noise ratios for 6 test sequences, using h30 and dictionaries according to the present invention. In all cases, and improved SNR is achieved.					
Sequence	kbps	fps	PSNR with h30 [dB]	PSNR with new dictionary [dB]	Gain [dB]
Foreman	112.6	30	33.05	33.49	0.44
Foreman	62.5	10	32.89	33.07	0.18
Coast	156.0	30	32.11	32.59	0.48
Coast	81.5	10	31.94	32.19	0.25
Table tennis	59.5	30	33.28	33.55	0.27
Table tennis	47.6	10	22.16	33.27	0.11
Container	35.2	30	33.38	33.8	0.42
Container	17.3	10	33.22	33.46	0.24
Mobile	313.3	30	27.87	28.53	0.66
Stefan	313.3	30	29.74	30.3	0.56

The time required to run a complete set of learning simulations is around 4 days on a Silicon Graphics Onyx computer. The reasons are (a) the large number of patterns extracted from the training sequences for the learning phase, i.e. around 120,000 patterns of size  $35 \times 35$ , (b) the successive training cycles necessary to prune the original dictionary from 1416 to 472 functions, and (c) the computation of the Huffman codes for the different atom parameters, such as position, amplitude, and label. The test phase requires additional computation time as well. It is expected that these run times can be reduced by further tuning of the algorithms and optimization of the software.

This presents one of many examples of a reduction to practice for the invention, but its presentation here is not

meant to imply that this is the only or even the optimal result that can be eventually achieved using this invention. Possible variations would be to design dictionaries for different classes of video sequences such as animations, high motion sports, head and shoulders, and so forth, using sequences from those individual classes. We expect that improvements can be made in the approximation of the dictionary functions that leads to an efficient implementation as well.

The previous descriptions of the invention and specific embodiments are presented for illustration purposes only, and are not intended to be limiting. Modifications and changes may be apparent and obvious to those skilled in the art, and it is intended that this invention be limited only by the scope of the appended claims.

We claim:

1. A method for creating a dictionary for video compression, comprising:

[(a)] designating an initial reference dictionary of functions [.] stored in a memory;

[(b)] designating a set of video sequences to be used as training sequences[.];

[(c)] calculating [the] a motion residual image for at least one of the frames of a video sequence from the set of video sequences[.];

[(d)] determining an energy threshold for evaluating the residual image[.];

[(e)] evaluating the residual image for portions above the energy threshold;

[(f)] comparing a first high energy portion of the residual image to at least one function in the reference dictionary[.];

[(g)] extracting the first high energy portion of the residual image[.];

[(i)] storing the extracted high energy portion of the residual image [.] in the memory; and

[(j)] synthesizing, using a processing device, the dictionary from the stored high energy portion of the residual image[.], in which the step of synthesizing comprises] by dividing the extracted high energy portions into at least two subsets based on an inner product calculation, and calculating an updated dictionary pattern from the elements in the two subsets.

2. The method of claim 1, [in which the step of] wherein the calculating further comprises:

$$\hat{x}_{j,n+1} = \frac{\sum_{x_i \in S_{j,n}^{(+)}} \omega_i x_i}{\sum_{x_i \in S_{j,n}^{(+)}} \omega_i} - \frac{\sum_{x_i \in S_{j,n}^{(-)}} \omega_i x_i}{\sum_{x_i \in S_{j,n}^{(-)}} \omega_i}.$$

3. The method of claim 1, further comprising [the steps of]:

[(k)] revising the residual image[.]; and

[(l)] repeating [steps (f)–(i)] the comparing, extracting, and storing for at least a second high energy portion of the residual image, after [said] the first high energy portion has been extracted.

4. A dictionary for use in video compression, [said] the dictionary having been generated by:

[(a)] designating an initial reference dictionary of functions[.];

[(b)] designating a set of video sequences to be used as training sequences[.];



- [(c)] calculating the motion residual image for at least one of the frames of a video sequence from the set of video sequences[.];
- [(d)] determining an energy threshold for evaluating the residual image[.];
- [(e)] evaluating the residual image for portions above the energy threshold;
- [(f)] comparing a first high energy portion of the residual image to at least one function in the reference dictionary[.];
- [(g)] extracting the first high energy portion of the residual image[.];
- [(i)] storing the extracted high energy portion of the residual image[.];
- [(j) synthesis] *synthesizing* from the stored high energy portion of the residual image, [in which] *wherein* the [step of synthesis] *synthesizing* comprises dividing the extracted high energy portions into at least two subsets based on an inner product calculation, and calculating an updated dictionary pattern from the elements in the two subsets.
5. The [method] *dictionary* of claim 4, [in which the step of] *wherein* the calculating *further* comprises:

$$\hat{x}_{j,n+1} = \frac{\sum_{x_i \in S_{j,n}^{(+)}} \omega_i x_i}{\sum_{x_i \in S_{j,n}^{(+)}} \omega_i} - \frac{\sum_{x_i \in S_{j,n}^{(-)}} \omega_i x_i}{\sum_{x_i \in S_{j,n}^{(-)}} \omega_i}.$$

6. The [method] *dictionary* of claim 4, *wherein* the *generating* further [comprising the steps of] *comprises*:

- [(k)] revising the residual image[.]; and
- [(l)] repeating [steps (f)-(i)] *the comparing, extracting, and storing* for at least a second high energy portion of the residual image, after [said] *the* first high energy portion has been extracted.
7. A video encoding system [containing] *comprising* a dictionary generated by:
- [(a)] designating an initial reference dictionary of functions[.];
- [(b)] designating a set of video sequences to be used as training sequences[.];
- [(c)] calculating the motion residual image for at least one of the frames of a video sequence from the set of video sequences[.];
- [(d)] determining an energy threshold for evaluating the residual image[.];
- [(e)] evaluating the residual image for portions above the energy threshold;
- [(f)] comparing a first high energy portion of the residual image to at least one function in the reference dictionary[.];
- [(g)] extracting the first high energy portion of the residual image[.];
- [(i)] storing the extracted high energy portion of the residual image[.]; *and*
- [(j) synthesis] *synthesizing* from the stored high energy portion of the residual image, [in which the step of synthesis] *wherein* the *synthesizing* comprises dividing the extracted high energy portions into at least two subsets based on an inner product calculation, and calculating an updated dictionary pattern from the elements in the two subsets.

8. The [method] *video encoding system* of claim 7, [in which the step of] *wherein* the calculating comprises:

$$\hat{x}_{j,n+1} = \frac{\sum_{x_i \in S_{j,n}^{(+)}} \omega_i x_i}{\sum_{x_i \in S_{j,n}^{(+)}} \omega_i} - \frac{\sum_{x_i \in S_{j,n}^{(-)}} \omega_i x_i}{\sum_{x_i \in S_{j,n}^{(-)}} \omega_i}.$$

9. The [method] *video encoding system* of claim 7, [further comprising the steps of] *wherein* the *dictionary* is *further generated* by:

- [(k)] revising the residual image[.]; and

- [(l)] repeating [steps (f)-(i)] *the comparing, extracting, and storing* for at least a second high energy portion of the residual image, after [said] *the* first high energy portion has been extracted.

10. A machine readable medium [upon which are stored] *having* instructions [to generate a dictionary for video compression according to the method comprising steps of] *stored thereon that are executed by a processing device causing the processing device to perform operations comprising*:

- [(a)] designating an initial reference dictionary of functions[.];

- [(b)] designating a set of video sequences to be used as training sequences[.];

- [(c)] calculating the motion residual image for at least one of the frames of a video sequence from the set of video sequences[.];

- [(d)] determining an energy threshold for evaluating the residual image[.];

- [(e)] evaluating the residual image for portions above the energy threshold;

- [(f)] comparing a first high energy portion of the residual image to at least one function in the reference dictionary[.];

- [(g)] extracting the first high energy portion of the residual image[.];

- [(i)] storing the extracted high energy portion of the residual image[.]; *and*

- [(j) synthesis] *synthesizing* from the stored high energy portion of the residual image, [in which the step of synthesis] *wherein* the *synthesizing* comprises dividing the extracted high energy portions into at least two subsets based on an inner product calculation, and calculating an updated dictionary pattern from the elements in the two subsets.

11. The [method] *machine readable medium* of claim 10, [in which the step of] *wherein* the calculating comprises:

$$\hat{x}_{j,n+1} = \frac{\sum_{x_i \in S_{j,n}^{(+)}} \omega_i x_i}{\sum_{x_i \in S_{j,n}^{(+)}} \omega_i} - \frac{\sum_{x_i \in S_{j,n}^{(-)}} \omega_i x_i}{\sum_{x_i \in S_{j,n}^{(-)}} \omega_i}.$$

12. The [method] *machine readable medium* of claim 10, further comprising [the steps of]:

- [(k)] revising the residual image[.]; and

- [(l)] repeating [steps (f)-(i)] *the comparing, extracting, and storing* for at least a second high energy portion of the residual image, after [said] *the* first high energy portion has been extracted.



## 11

13. A video system comprising:  
 a memory;  
 a processor configured to:  
 calculate a residual image from at least one frame in a  
 video sequence; 5  
 identify a high energy portion of the residual image  
 above a predetermined threshold;  
 match regions of varying dimension centered about the  
 high energy portion of the residual image with ele-  
 ments in an initial dictionary; 10  
 extract the matched region from the residual image;  
 store the matched region in the memory as a pattern;  
 repeat the calculate, identify, match, extract, and store  
 for other residual images in other frames of the video  
 sequence until all high energy portions in the other  
 residual images are matched; 15  
 synthesize an updated dictionary according to the ini-  
 tial dictionary and the stored patterns;  
 calculate a set of inner products between the stored  
 patterns and elements in the initial dictionary;  
 divide the stored patterns in at least two sets of patterns 20  
 and the elements in the initial dictionary into at least  
 two sets of elements responsive to a sign of a corre-  
 sponding one of the inner products; and  
 calculate code vectors for the updated dictionary  
 according to the at least two sets of patterns and the 25  
 at least two sets of elements.
14. The video system of claim 13 wherein the processor is  
 further configured to:  
 replace the initial dictionary with the updated dictionary. 30
15. The video system of claim 13 wherein the processor is  
 further configured to:  
 update code vectors of the updated dictionary; and  
 replace the initial dictionary with the updated dictionary  
 after the update. 35
16. The video system of claim 13 wherein the processor is  
 further configured to:  
 calculate the code vectors for the updated dictionary  
 according to an energy of at least one of the stored  
 patterns. 40
17. A video system comprising:  
 a storage means;  
 a processing means configured to:

## 12

- calculate a residual image from at least one frame in a  
 video sequence;  
 identify a high energy portion of the residual image  
 above a predetermined threshold;  
 match regions of varying dimension centered about the  
 high energy portion of the residual image with ele-  
 ments in an initial dictionary;  
 extract the matched region from the residual image;  
 store the matched region in the storage means as a  
 pattern;  
 repeat the calculating, identifying, matching,  
 extracting, and storing for other residual images in  
 other frames of the video sequence until all high  
 energy portions in the other residual images are  
 matched;  
 synthesize an updated dictionary responsive to calcu-  
 lating at least one metric between the stored patterns  
 and elements in the initial dictionary;  
 calculate a set of inner products between the stored  
 patterns and elements in the initial dictionary;  
 divide the stored patterns in at least two sets of patterns  
 and the elements in the initial dictionary into at least  
 two sets of elements responsive to a sign of corre-  
 sponding one of the inner products; and  
 calculate code vectors for the updated dictionary  
 according to the at least two sets of patterns and the  
 at least two sets of elements.
18. The video system of claim 17 wherein the processing  
 means is further configured to:  
 replace the initial dictionary with the updated dictionary. 30
19. The video system of claim 17 wherein the processing  
 means is further configured to:  
 update code vectors of the updated dictionary; and  
 replace the initial dictionary with the updated dictionary  
 after the updating. 35
20. The video system of claim 17 wherein the processing  
 means is further configured to:  
 calculate the code vectors for the updated dictionary  
 according to an energy of at least one of the stored  
 patterns. 40

\* \* \* \* \*