

US00RE42258E

(19) **United States**
(12) **Reissued Patent**
Thompson et al.

(10) **Patent Number:** **US RE42,258 E**
(45) **Date of Reissued Patent:** **Mar. 29, 2011**

(54) **OUTSIDE PLANT FIBER DISTRIBUTION APPARATUS AND METHOD**

4,652,072 A 3/1987 Arasi, Jr.
4,669,802 A 6/1987 Schaffer
4,717,231 A 1/1988 Dewez et al.
4,785,376 A 11/1988 Dively
4,805,979 A 2/1989 Bossard et al.

(75) Inventors: **Patrick Thompson**, Roseville, MN (US); **Brian L. Johnson**, Maple Grove, MN (US); **Anthony L. Tischler**, Hastings, MN (US)

(Continued)

FOREIGN PATENT DOCUMENTS

(73) Assignee: **ADC Telecommunications, Inc.**, Eden Prairie, MN (US)

DE 1 430 906 9/1969

(Continued)

(21) Appl. No.: **12/218,240**

OTHER PUBLICATIONS

(22) Filed: **Jul. 11, 2008**

(Under 37 CFR 1.47)

ADC Telecommunications, Fiber Pedestal Termination Box Installation Instructions, ADCP-93-074, pp. 1-14 Issue 4 (Mar. 1999).

(Continued)

Related U.S. Patent Documents

Reissue of:

(64) Patent No.: **6,363,200**
Issued: **Mar. 26, 2002**
Appl. No.: **09/689,989**
Filed: **Oct. 13, 2000**

Primary Examiner—Michelle R Connelly Cushwa
(74) *Attorney, Agent, or Firm*—Merchant & Gould P.C.

(57) **ABSTRACT**

U.S. Applications:

(60) Continuation of application No. 11/397,885, filed on Apr. 4, 2006, which is a division of application No. 09/122,947, filed on Jul. 27, 1998, now Pat. No. 6,160,946.

An outside plant fiber distribution apparatus includes a frame member and a plurality of fiber optic modules mounted to the frame member. The frame member includes upper and lower module mounting brackets. Each module includes a front and two mounting flanges, each mountable to one of the upper and lower module mounting brackets. At least one of the modules is configured as a connection module including a plurality of connection locations disposed along the front of the module. A rear of the module includes a cable notch region for receipt of a cable. At least one of the modules defines a storage module including first and second spools. In an interconnect system, the storage module includes a cable clamp for holding a second cable, the cables are connected through the connection locations of the connection module. In a cross-connect system, two connection modules are provided, and patch cords are used to connect the fronts of the connection modules. The modules may also house splices, and/or optical couplers, such as splitters and wave division multiplexers.

(51) **Int. Cl.**
G02B 6/00 (2006.01)
G02B 6/46 (2006.01)
H05K 7/00 (2006.01)

(52) **U.S. Cl.** **385/135; 385/136; 361/728; 174/50**

(58) **Field of Classification Search** **385/135**
See application file for complete search history.

(56) **References Cited**

U.S. PATENT DOCUMENTS

2,853,775 A 9/1958 Drake
3,348,642 A 10/1967 Kosche
4,213,018 A 7/1980 Piston
4,273,413 A 6/1981 Bendiksen et al.

50 Claims, 21 Drawing Sheets

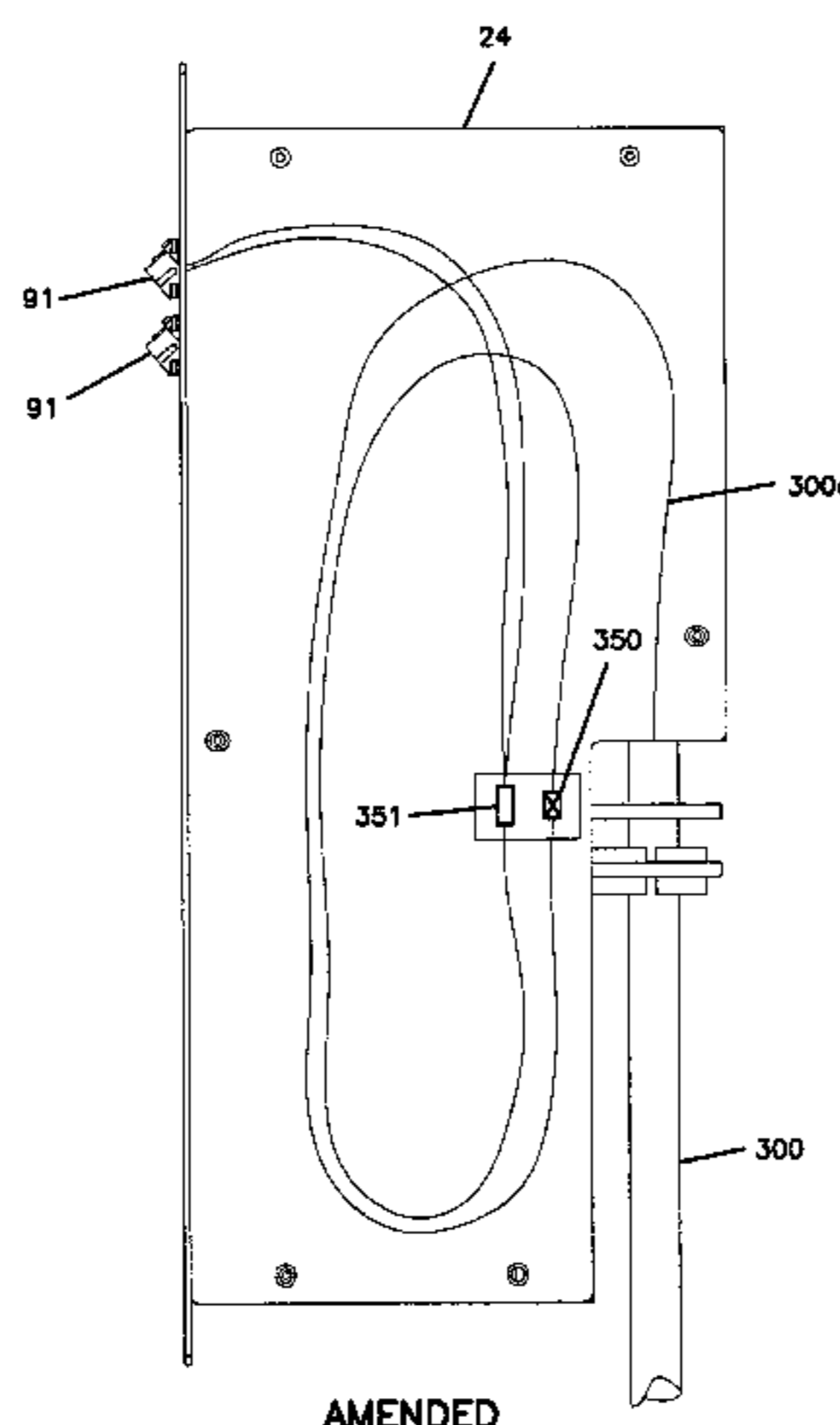

AMENDED

U.S. PATENT DOCUMENTS

4,932,742 A 6/1990 Tohme
 4,958,903 A 9/1990 Cobb et al.
 4,960,317 A 10/1990 Briggs et al.
 4,986,762 A 1/1991 Keith
 4,989,939 A 2/1991 Cox et al.
 4,995,688 A 2/1991 Anton et al.
 5,029,958 A 7/1991 Hodge et al.
 5,031,984 A 7/1991 Eide et al.
 5,046,811 A 9/1991 Jung et al.
 5,077,815 A 12/1991 Yoshizawa et al.
 5,093,885 A 3/1992 Anton
 5,097,529 A 3/1992 Cobb et al.
 5,122,069 A 6/1992 Brownlie et al.
 5,127,082 A * 6/1992 Below et al. 385/135
 5,129,030 A 7/1992 Petrunia
 5,133,038 A 7/1992 Zipper
 5,133,039 A 7/1992 Dixit
 5,179,618 A 1/1993 Anton
 5,204,929 A 4/1993 Machall et al.
 5,212,761 A * 5/1993 Petrunia 385/135
 5,214,735 A 5/1993 Henneberger et al.
 5,231,687 A 7/1993 Handley
 5,235,665 A 8/1993 Marchesi et al.
 5,267,122 A 11/1993 Glover et al.
 5,363,465 A 11/1994 Korkowski et al.
 5,367,598 A 11/1994 Devenish, III et al.
 RE34,955 E 5/1995 Anton et al.
 5,432,875 A 7/1995 Korkowski et al.
 5,446,822 A 8/1995 Keith
 5,446,823 A 8/1995 Bingham et al.
 5,495,549 A 2/1996 Schneider et al.
 5,509,099 A 4/1996 Hermsen et al.
 5,633,973 A 5/1997 Vincent et al.
 5,645,449 A 7/1997 Sabo
 5,659,650 A 8/1997 Arnett
 5,689,607 A 11/1997 Vincent et al.
 5,701,380 A 12/1997 Larson et al.
 5,708,742 A 1/1998 Beun et al.
 5,732,180 A 3/1998 Kaplan
 5,734,776 A 3/1998 Puetz
 5,741,158 A 4/1998 Reed et al.
 5,745,633 A 4/1998 Giebel et al.
 5,758,003 A 5/1998 Wheeler et al.
 5,778,122 A 7/1998 Giebel et al.
 5,781,678 A 7/1998 Sano et al.
 5,828,807 A 10/1998 Tucker et al.
 5,887,106 A * 3/1999 Cheeseman et al. 385/135
 5,892,870 A 4/1999 Fingler et al.
 5,894,540 A 4/1999 Drowing
 5,903,698 A 5/1999 Porembe et al.
 5,907,653 A 5/1999 Burek et al.
 5,917,648 A 6/1999 Harker
 5,956,449 A 9/1999 Otani et al.
 5,975,769 A 11/1999 Larson et al.
 RE36,592 E 2/2000 Giebel et al.
 6,160,946 A 12/2000 Thompson et al.
 6,167,183 A 12/2000 Swain
 6,198,866 B1 3/2001 Nikolaevich
 6,208,796 B1 3/2001 Williams Vigliaturo
 6,215,939 B1 4/2001 Cloud
 6,259,024 B1 7/2001 Daoud
 6,292,614 B1 9/2001 Smith et al.
 6,300,562 B1 10/2001 Daoud
 6,363,200 B1 3/2002 Thompson et al.
 6,439,779 B1 8/2002 Hafer
 6,453,106 B1 9/2002 Glaser et al.
 6,535,682 B1 3/2003 Puetz et al.
 6,621,975 B2 9/2003 Laporte et al.
 6,760,531 B1 7/2004 Solheid et al.
 6,766,094 B2 7/2004 Smith et al.

6,880,986 B2 4/2005 Mynatt et al.
 6,926,449 B1 8/2005 Keenum et al.
 7,013,074 B2 3/2006 Battey et al.
 7,120,347 B2 10/2006 Blackwell, Jr. et al.
 RE40,358 E 6/2008 Thompson et al.
 7,397,997 B2 7/2008 Ferris et al.
 2003/0077041 A1 4/2003 Belaidi et al.
 2003/0103750 A1 6/2003 Laporte et al.
 2004/0062508 A1 4/2004 Blankenship et al.
 2004/0211774 A1 10/2004 Daoud et al.
 2005/0094959 A1 5/2005 Sibley et al.
 2005/0129375 A1 6/2005 Elkins, II et al.
 2005/0145522 A1 7/2005 Bloodworth et al.
 2005/0163448 A1 7/2005 Blackwell, Jr. et al.
 2005/0175307 A1 8/2005 Battey et al.
 2005/0175308 A1 8/2005 Elkins, II et al.
 2005/0185895 A1 8/2005 Keenum et al.
 2005/0213921 A1 9/2005 Mertesdorf et al.
 2005/0220421 A1 10/2005 Keenum et al.
 2006/0153517 A1 7/2006 Reagan et al.
 2006/0193588 A1 8/2006 Mertesdorf et al.
 2007/0140642 A1 6/2007 Mertesdorf et al.

FOREIGN PATENT DOCUMENTS

DE 39 00 021 A1 10/1990
 EP 0 511 147 A1 10/1992
 EP 0 805 536 A1 11/1997
 EP 0 844 504 A2 5/1998
 EP 0 851 257 A1 7/1998
 FR 2 667 955 A1 4/1992
 FR 2 853 775 2/2004
 JP 58105114 6/1983
 JP 60169813 9/1985
 JP 61-2603 1/1986
 JP 61-9387 1/1986
 JP 62-181903 8/1987
 JP 63-130317 6/1988
 JP 63-188607 8/1988
 JP 63-200105 8/1988
 JP 63-257701 10/1988
 JP 1-177709 7/1989
 JP 1-225240 9/1989
 JP 1-265211 10/1989
 JP 4-309906 11/1992
 JP 5-84902 11/1993
 JP 6-181861 7/1994
 JP 6-337317 12/1994
 JP 8-114724 5/1996
 JP 9-15426 1/1997
 JP 10-133033 5/1998
 JP 11-508760 7/1999
 WO WO 95/07478 3/1995
 WO WO 02/06879 A1 1/2002

OTHER PUBLICATIONS

ADC Telecommunications, *Front-Facing Fiber Distribution Frame User Manual*, ADCP-90-177, 3rd Edition, Issue 2, 76 pages (May 1997).
 ADC Telecommunications, *FiberSeal® Terminal Enclosure Above Ground Application Installation Instructions*, ADCP-93-026, Issue 3, pp. 1-18 (May 1997).
 ADC Telecommunications, *Outside Plant FiberSeal® Terminal Enclosure Below Ground Application Installation Guide*, ADCP-93-019, 1st Edition, Issue 4, 24 pages (Oct. 1997).
 ADC Telecommunications, *Fiber Storage Panel Rack Mount User Manual*, ADCP-90-144, Issue 2, pp. 1-20 (May 1997).

- ADC Telecommunications, Termination Splice Module (TSM) Installation Instructions, ADCP-93-050, Issue 3, pp. 1-8 (Mar. 1999).
- ADC Telecommunications, FL1000 Installation and Operation Guide, ADCP-90-545, Issue 1, pp. 1-37 (Sep. 1998).
- ADC Telecommunications, Sliding 6-Pack 12-Fiber Wall Box User Manual, ADCP-90-537, Issue 1, pp. 1-17 (Jul. 1997).
- ADC Telecommunications, Fiber Bulkhead Drawer User Manual, ADCP-90-208, Issue 5, pp. 1-11 (Jun. 1998).
- Cobb, G.S. et al., "Fiber-to-the-Home Update: Drop Installation Flexibility," *International Wire & Cable Symposium Proceedings*, pp. 149-153 (1989).
- Siecor, AS2 Modified Shelf Kit and Preconnectorized Cable Installation in ADC Housing, SRP-003-488, Issue 1, 5 pages (Jul. 1998).
- Siecor, AS2 Shelf Kit and Preconnectorized Cable Installation in ADC Housing, SRP-003-381, Issue 4, 5 pages (Jul. 1998).
- Siecor, Bell Canada Multidwelling Service Entrance Enclosure (CAC®-HMD-008 and CAC-HMD-016), SRP-205-363, Issue 2, 4 pages (Apr. 1998).
- Siecor, Outside Plant Connector Panel for 2 Type Closure (PSI-BKT), SRP-003-331, Issue 2, 9 pages (May 1998).
- Siecor, New Product Information Pedestal Network Interface, SRP-206-218, Issue 2, 2 pages (Oct. 1998).
- Siecor, Outdoor Demarcation Cabinet, SRP-003-539, Issue 1, pp. 1-5 (Sep. 1999).
- Office Action from related U.S. Appl. No. 11/397,885, dated Apr. 1, 2008, 8 pages.
- Office Action from related U.S. Appl. No. 11/397,885, dated Oct. 29, 2008, 5 pages.
- Office Action from related U.S. Appl. No. 11/397,885, dated Aug. 12, 2009, 7 pages.
- Office Action from related U.S. Appl. No. 12/218,241; dated Apr. 29, 2009, 7 pages.
- ADC Telecommunications; "Above Ground Cross-Connect (AGX) Fiber Panel (AGX-1000HD) User Manual," ADCP-93-010, Issue 2, Jul. 1997, 26 pages.
- ADC Telecommunications; FL2000 Products; 6 pages; Nov. 1996.
- ADC Telecommunications; Fiber Panel Products Second Edition; 16 pages; Jul. 1996.
- ADC Telecommunications; Fiber Cable Management Products Third Edition; 22 pages; Jun. 1998.
- ADC Telecommunications; Value-Added Module System; 8 pages; Jun. 1998.
- ADC Telecommunications; FL2000™ Wall Mount Box Installation Instructions; 18 pages; ADCP-90-210 Issue 4; Jan. 1998.
- ADC Telecommunications; FTUA 4- and 12-Fiber Wall Box User Manual; 14 pages; ADCP-90-249 Issue 2; Mar. 1997.
- ADC Telecommunications; Wall Mount Box 12/24/36 Fiber User Manual; 16 pages; ADCP-90-149 Issue 3; Jul. 1997.
- ADC Telecommunications; FL1000 Wall-Mount Box Installation and Operation Guide; 28 pages; ADCP-90-334 Issue 1; Nov. 2004.
- ADC Telecommunications; FTDI 36-Fiber Wall Box User Manual; 15 pages; ADCP-90-250 Issue 1; Nov. 1996.
- ADC Telecommunications; Six-Fiber In-Building Wall Box Installation Instructions; 8 pages; ADCP-90-167 Issue 3; Nov. 1997.
- Office Action from related U.S. Appl. No. 11/397,885, dated Jan. 28, 2010, 11 pages.

* cited by examiner

FIG. 1

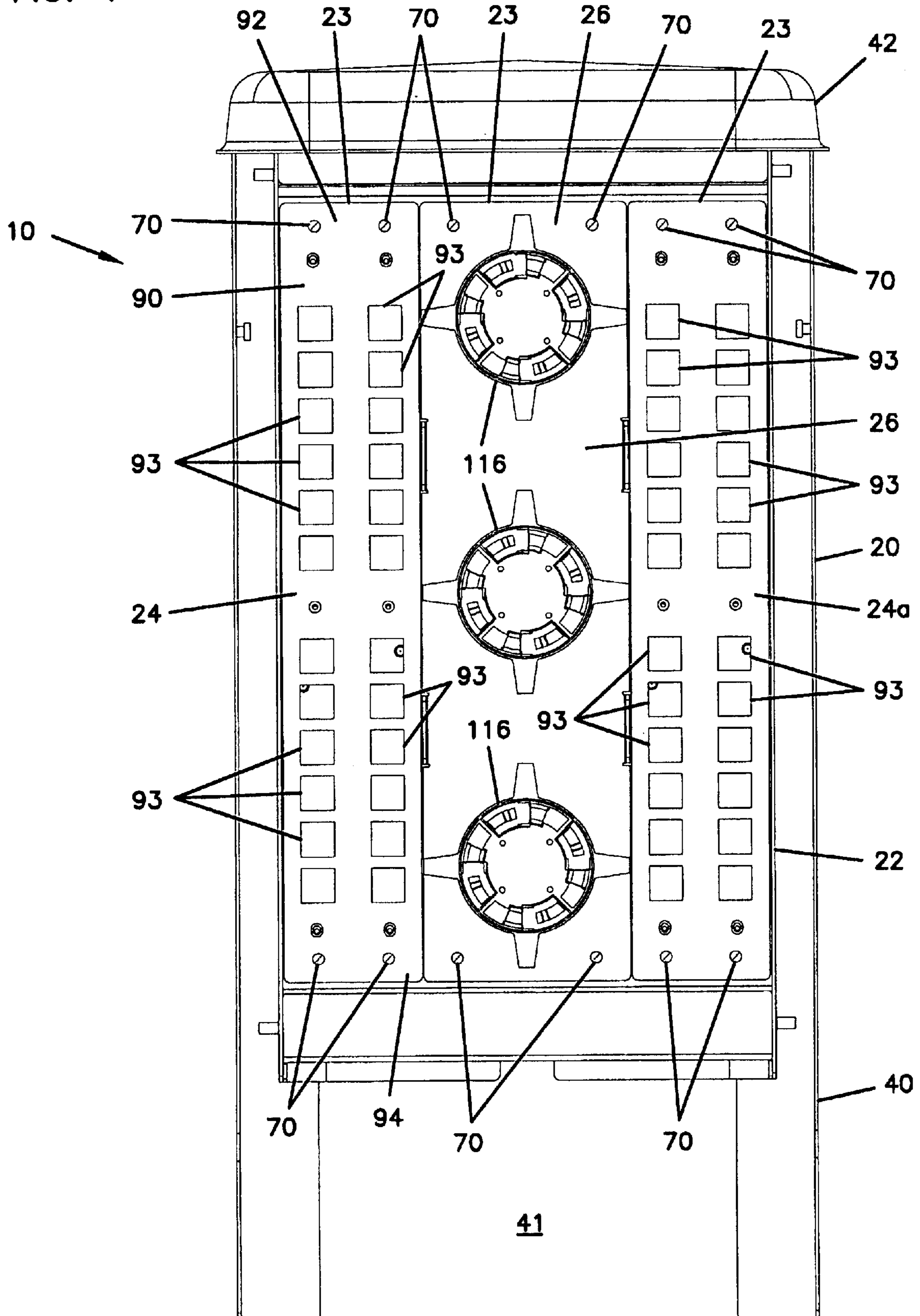

AMENDED

FIG. 2

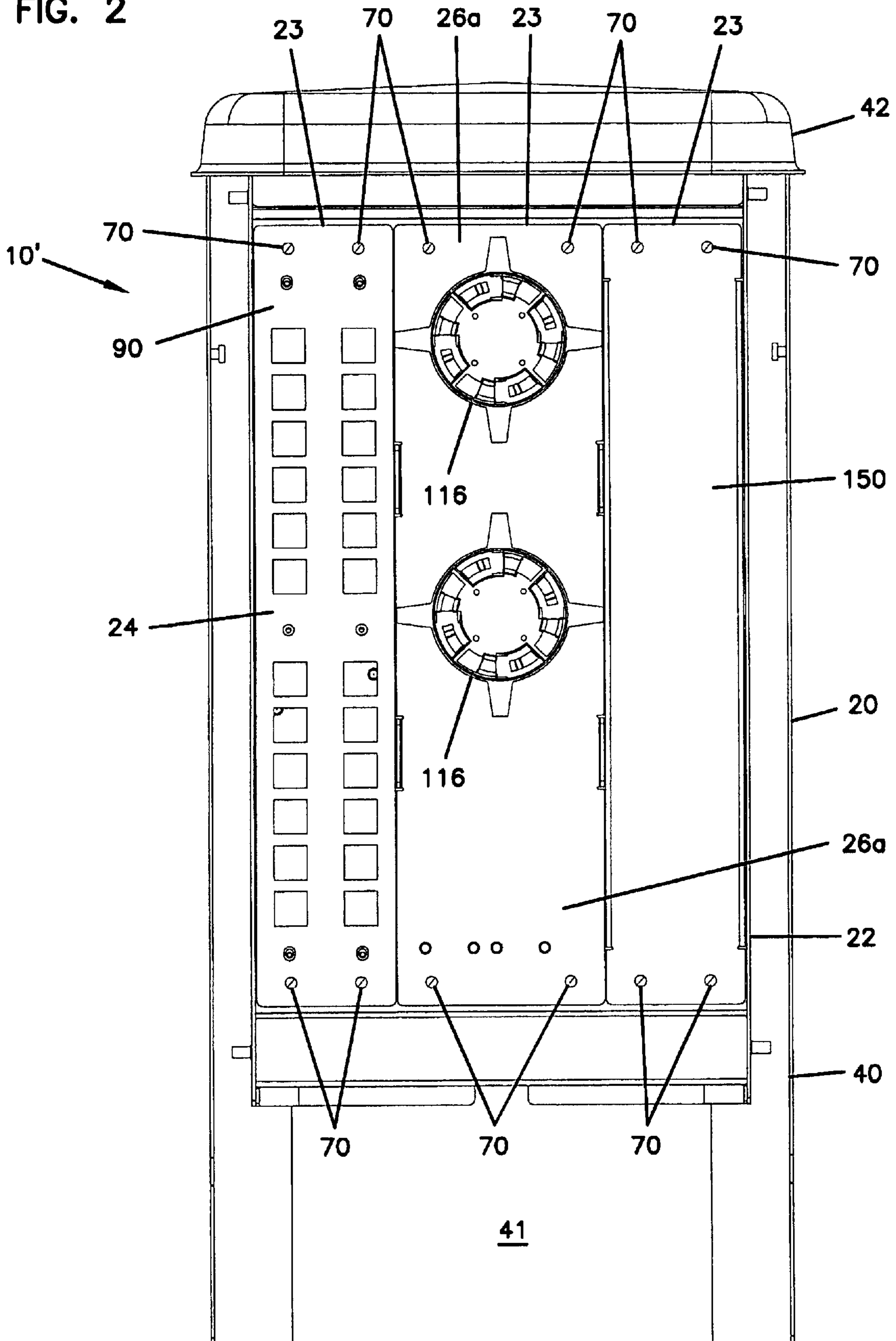

AMENDED

FIG. 3

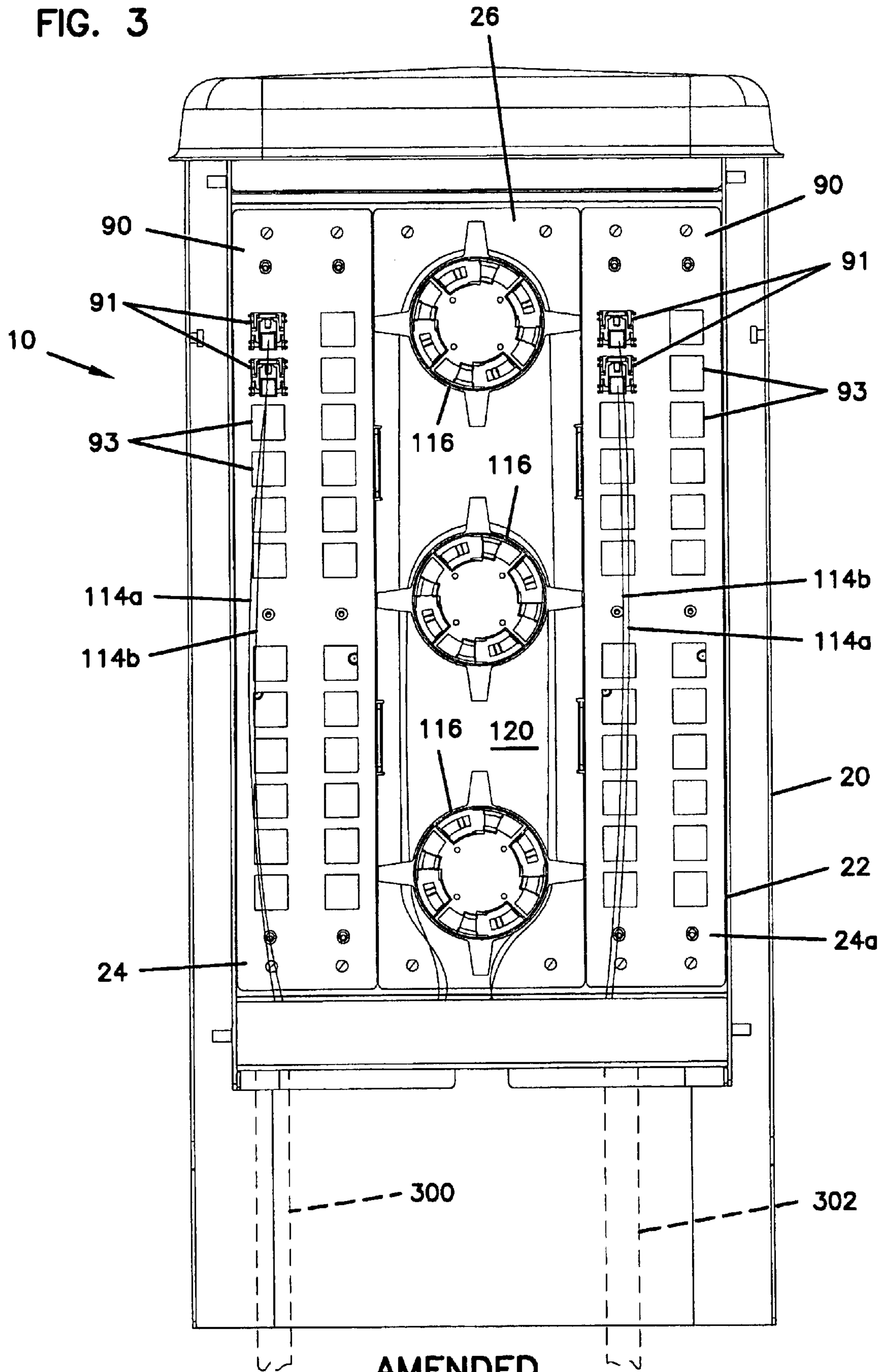

AMENDED

FIG. 4

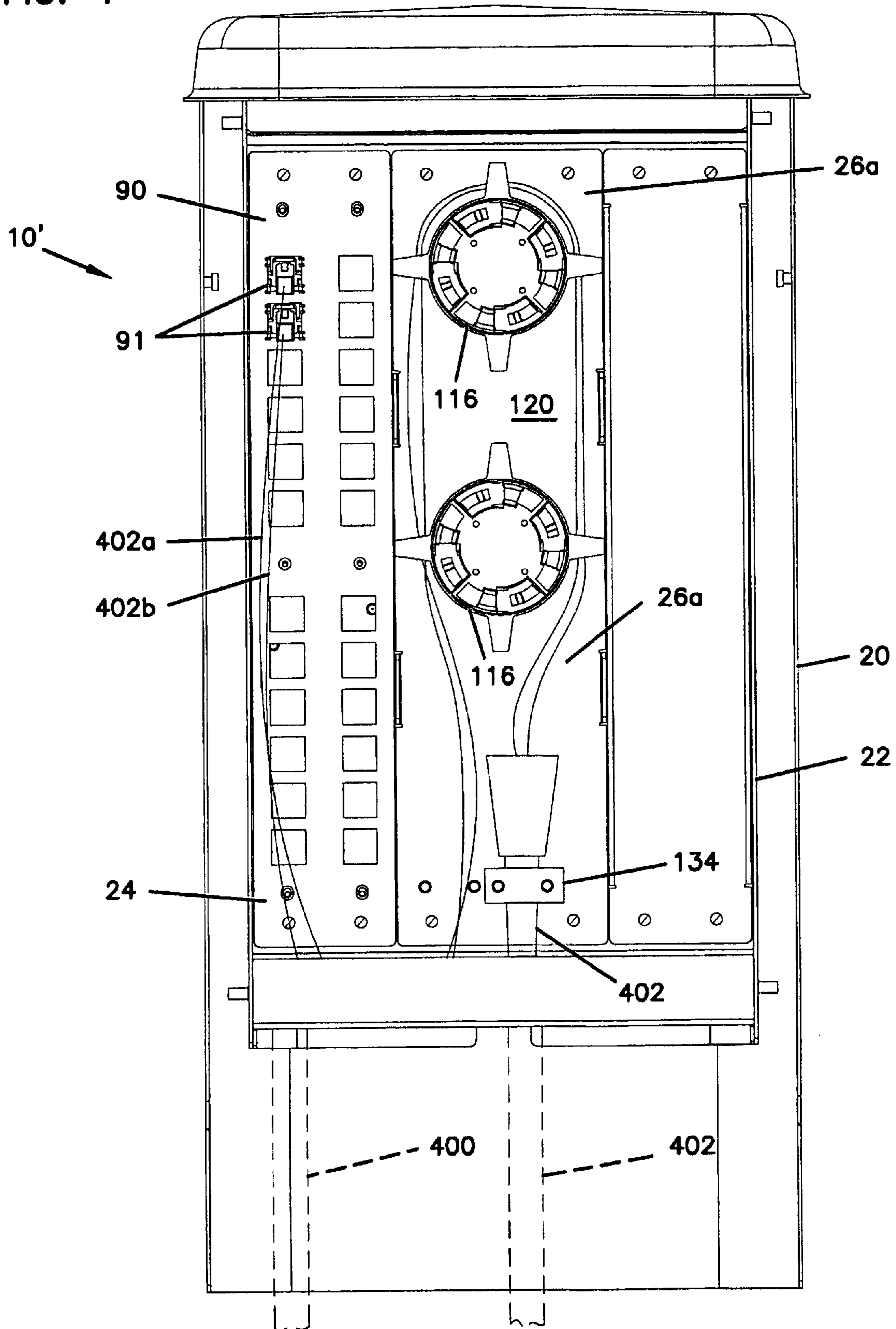

AMENDED

FIG. 5

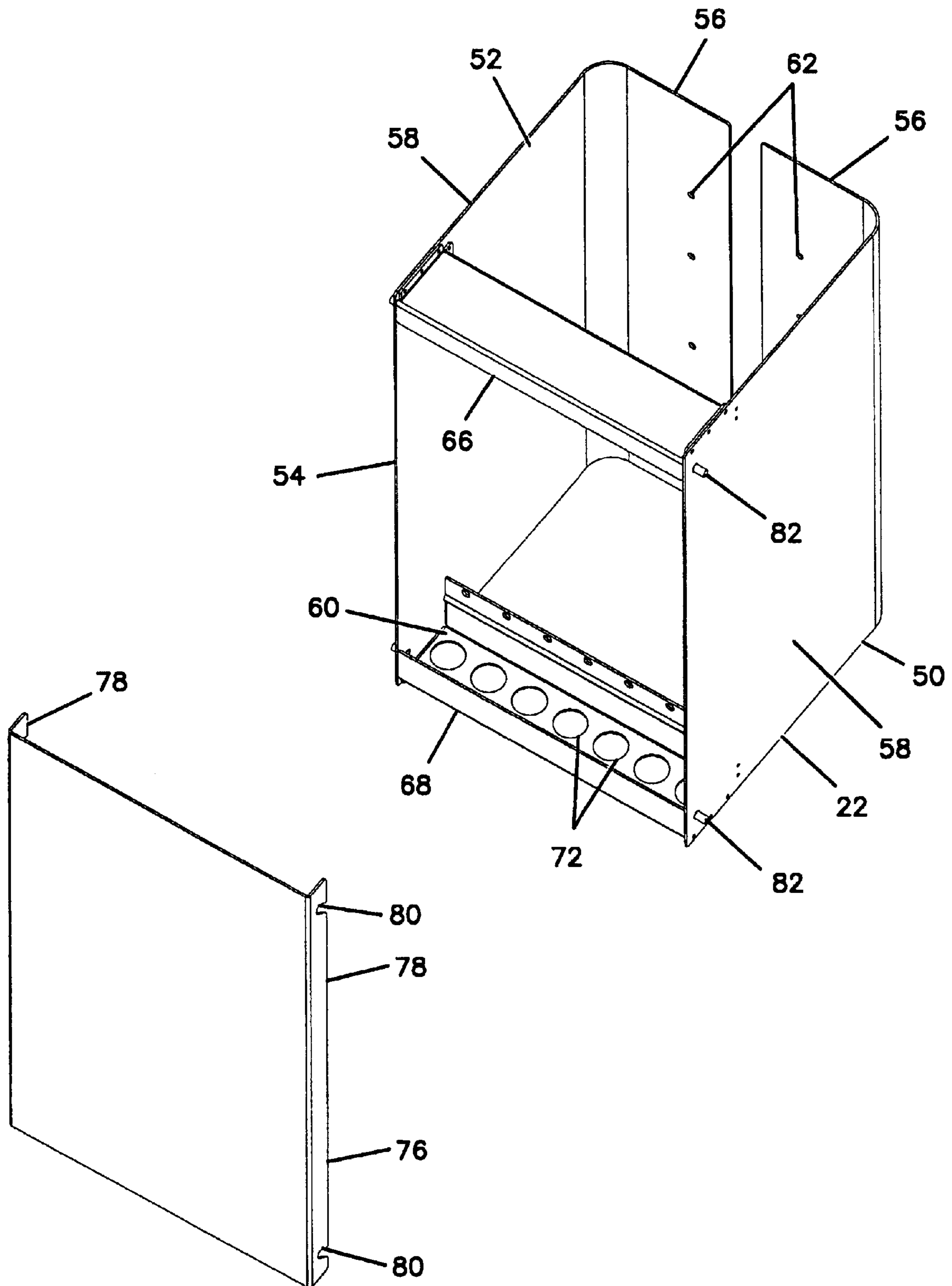

AMENDED

FIG. 6

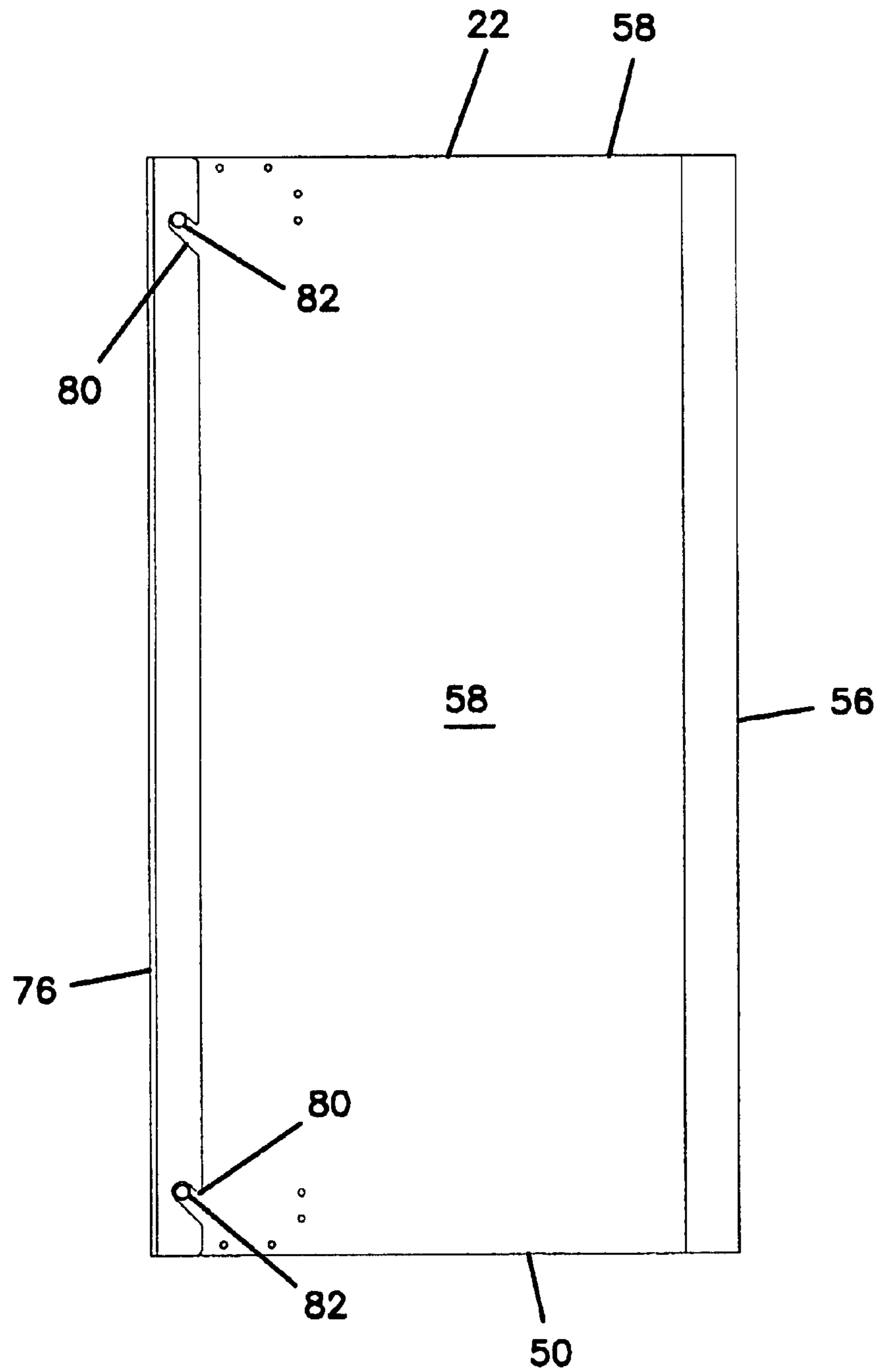

AMENDED

FIG. 7

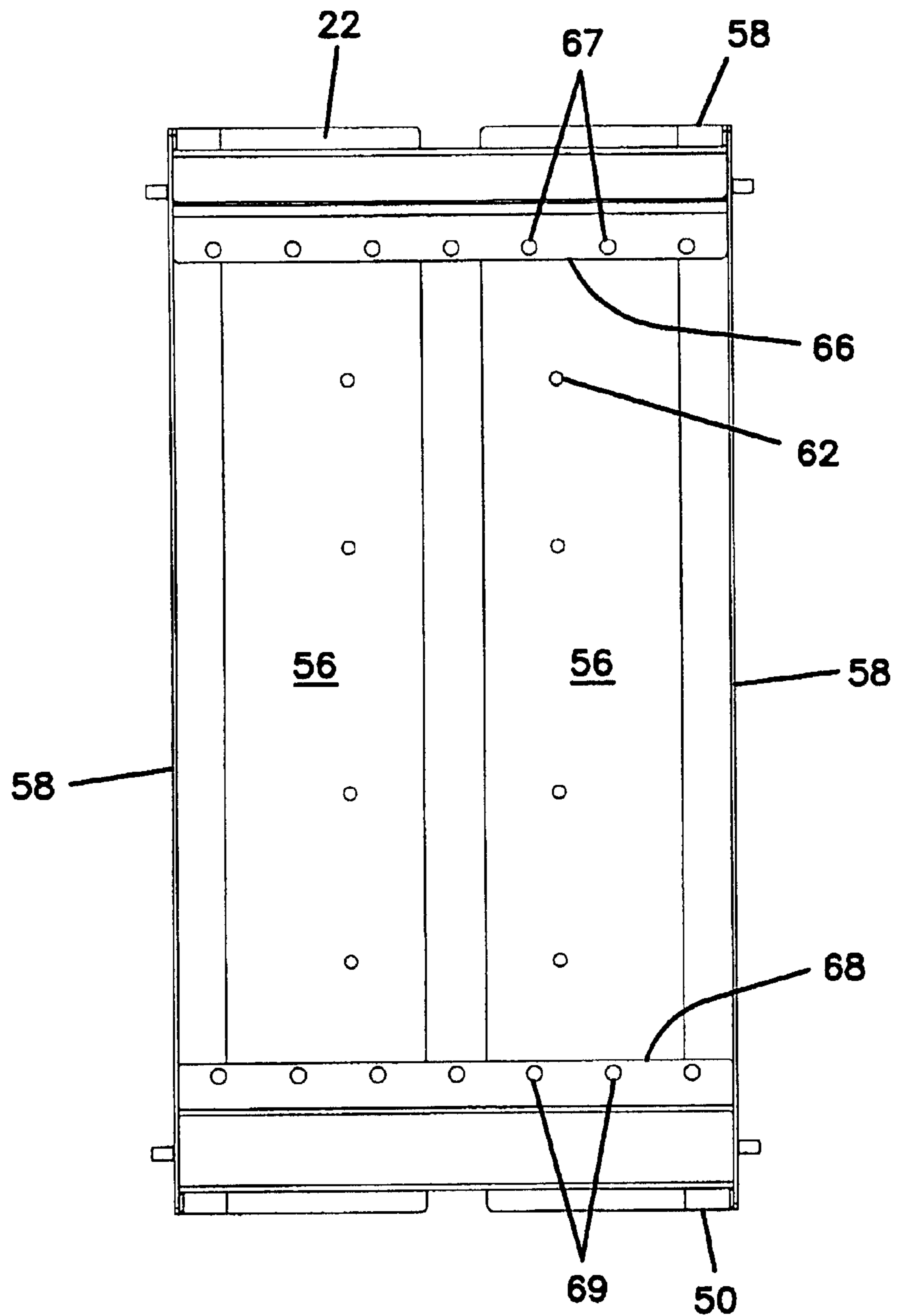

AMENDED

FIG. 8

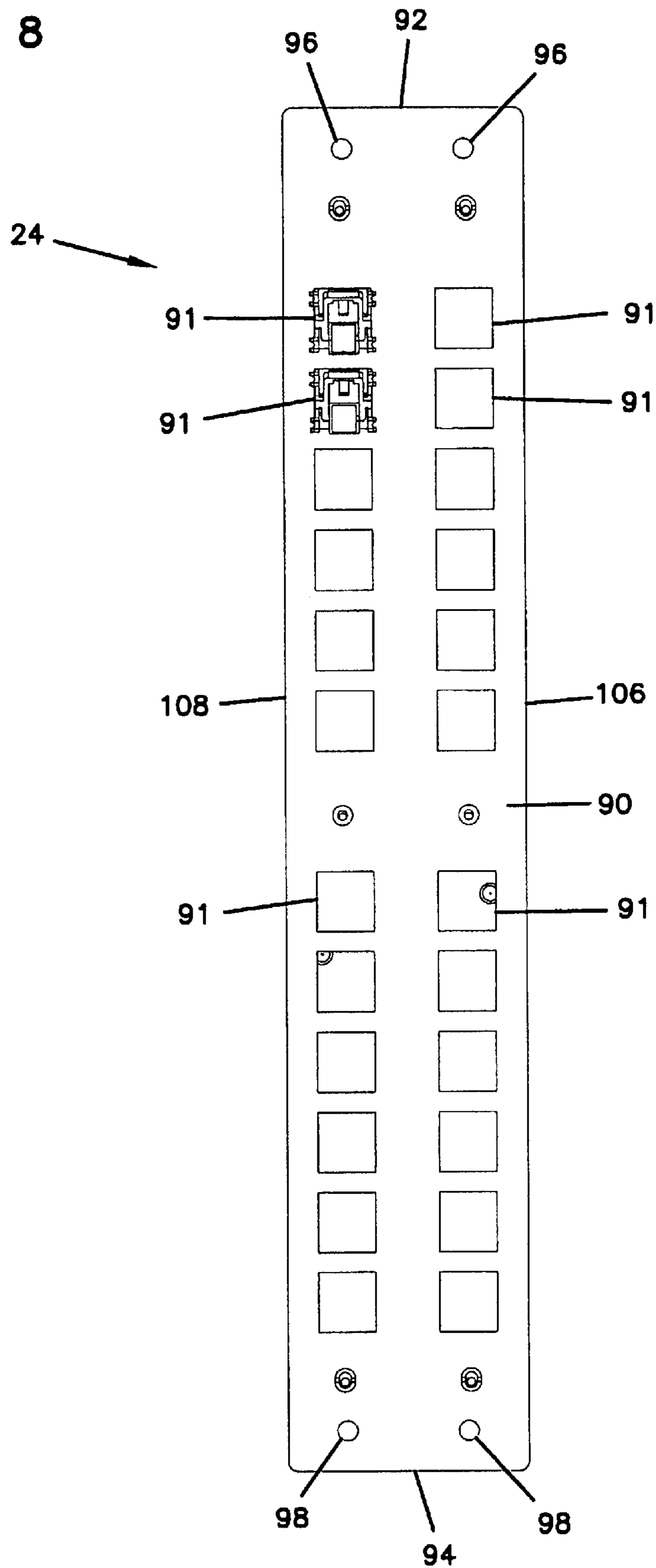

AMENDED

FIG. 9

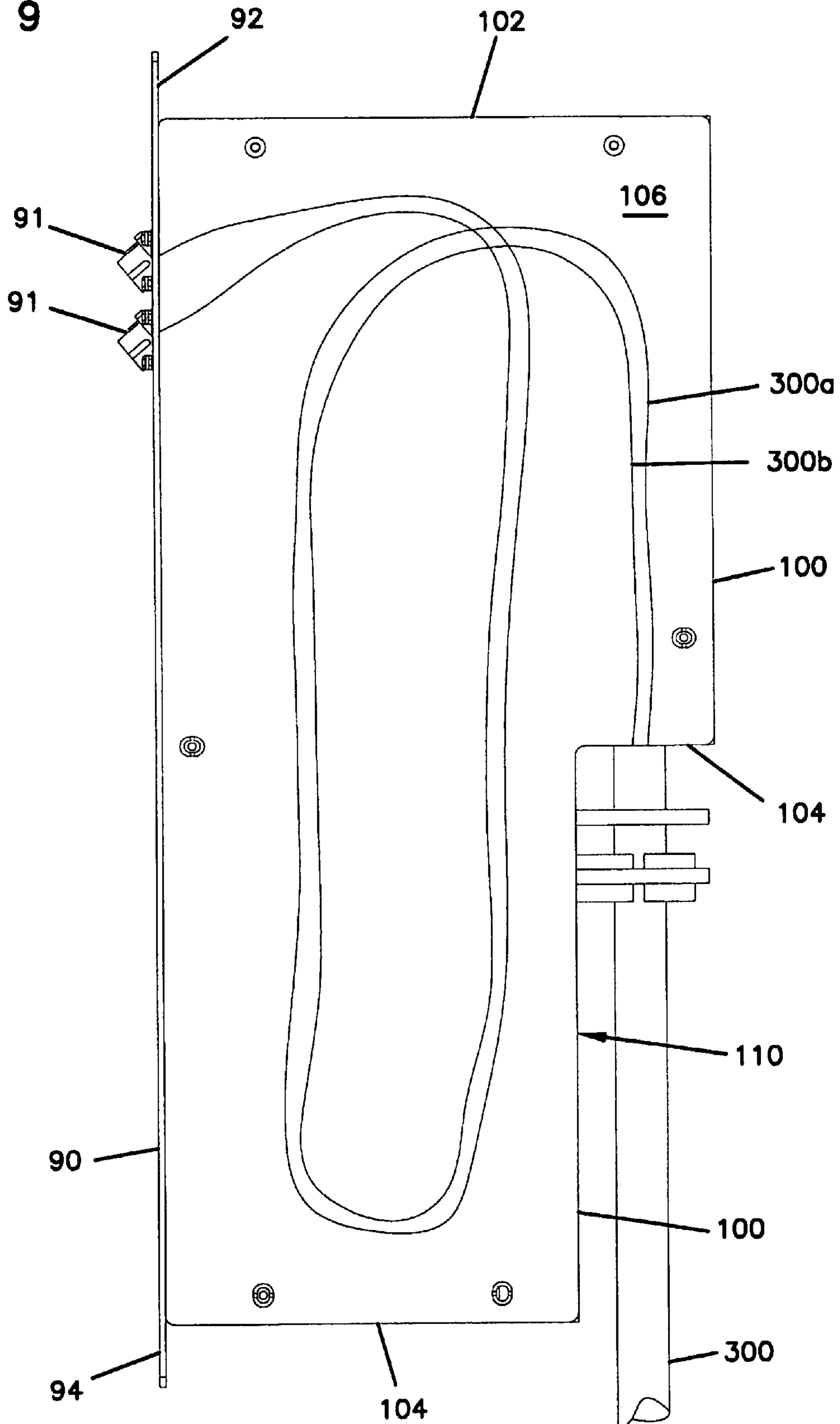

AMENDED

FIG. 10

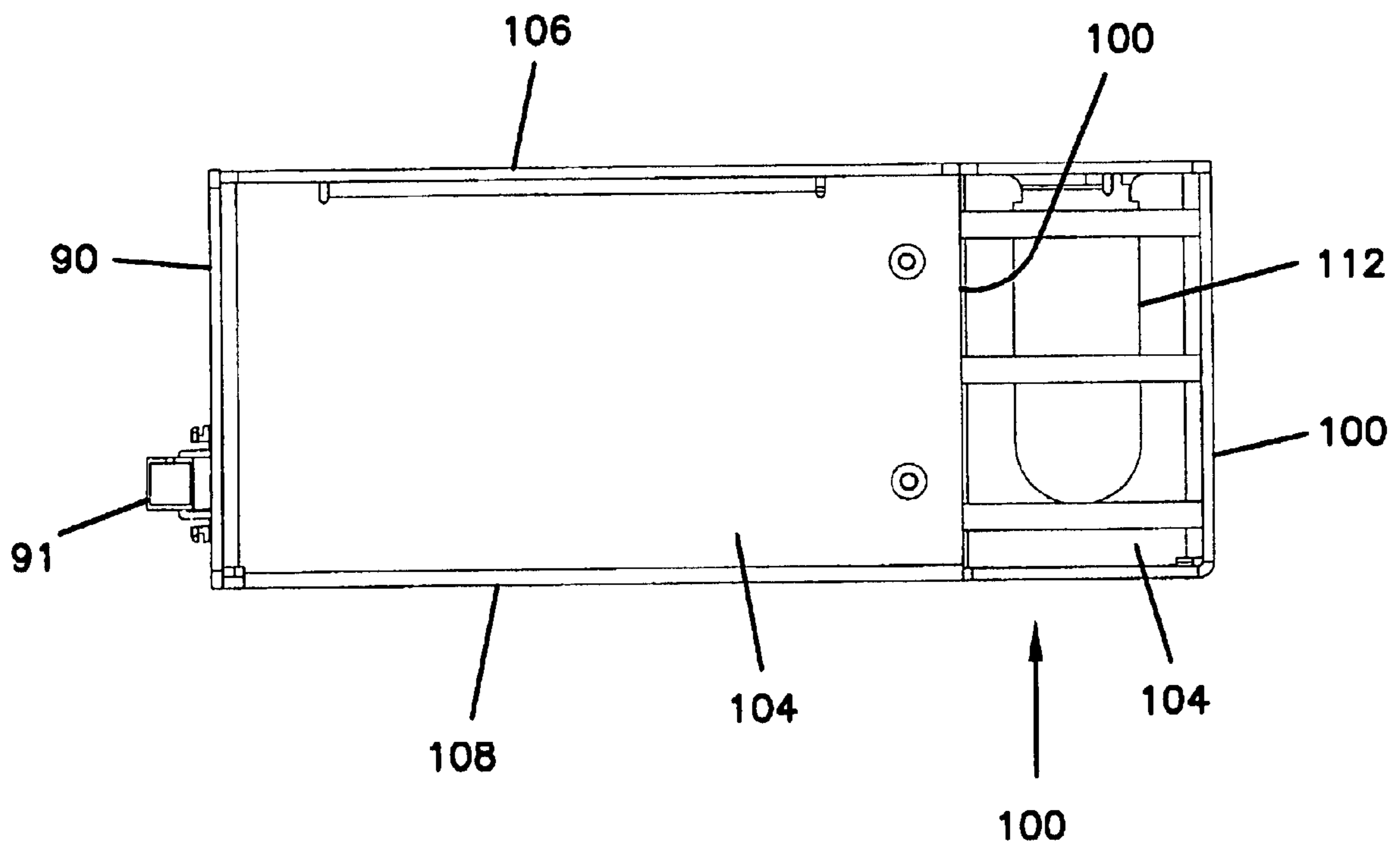

AMENDED

FIG. 11

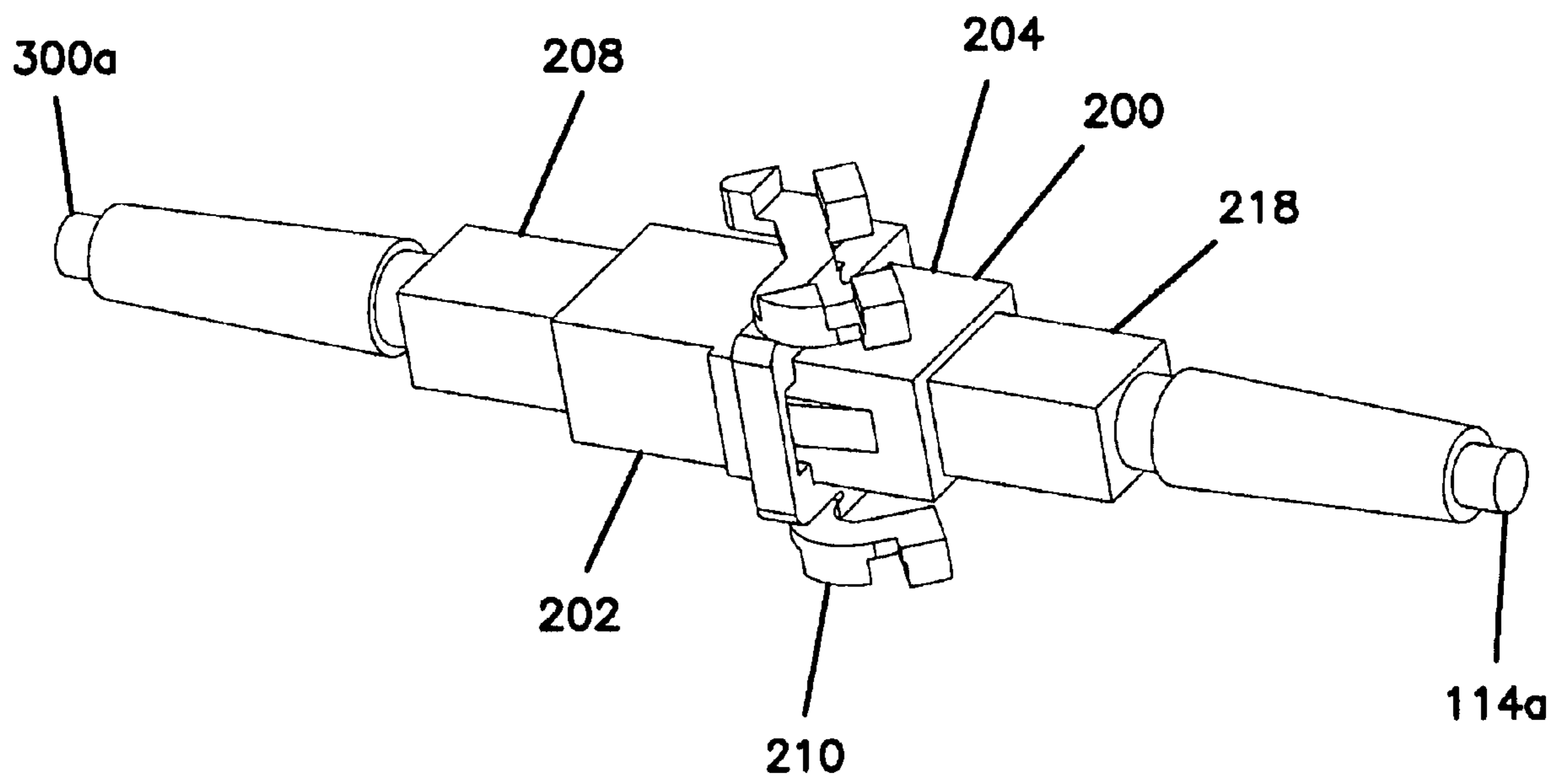

AMENDED

FIG. 12

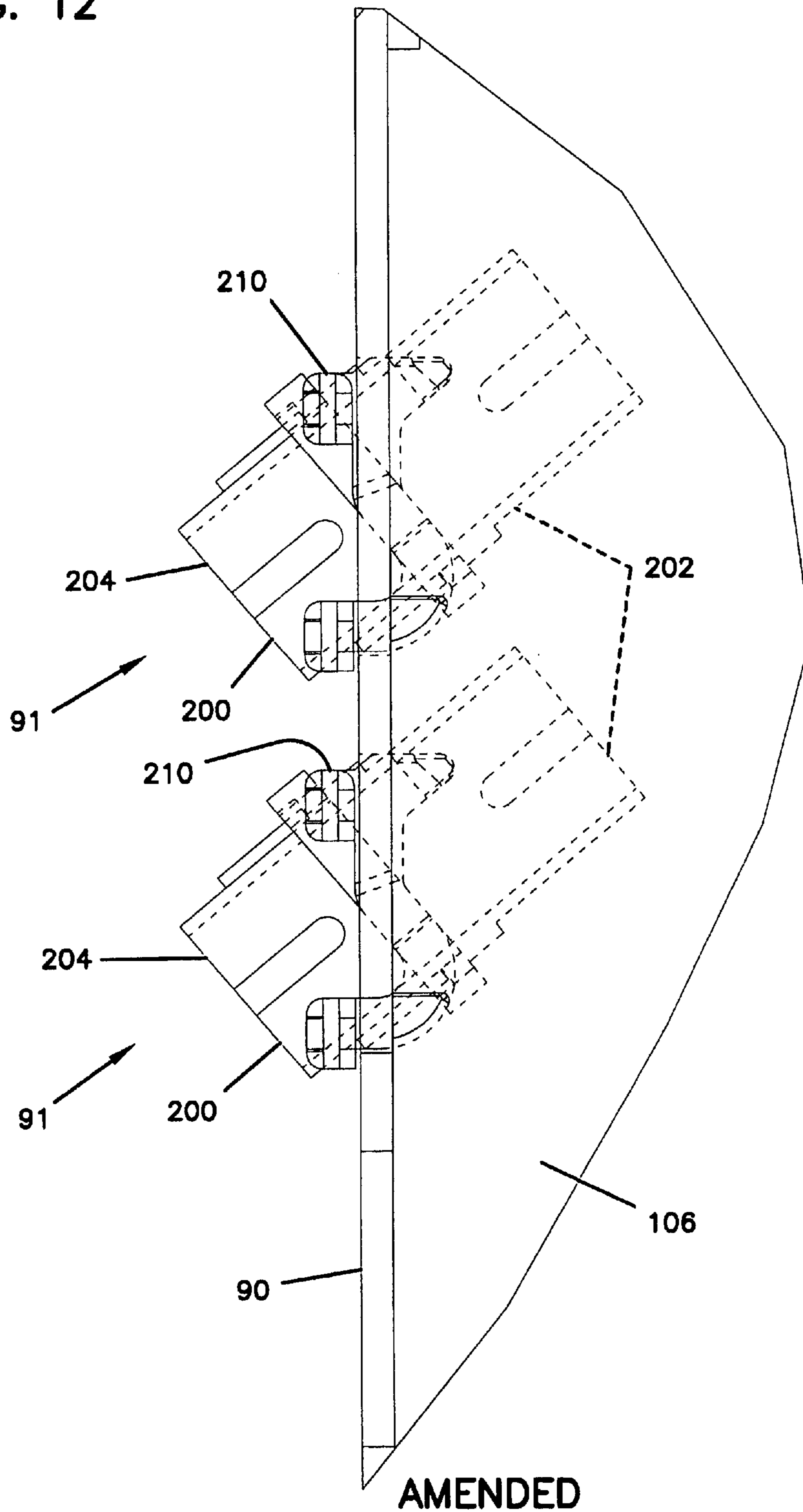
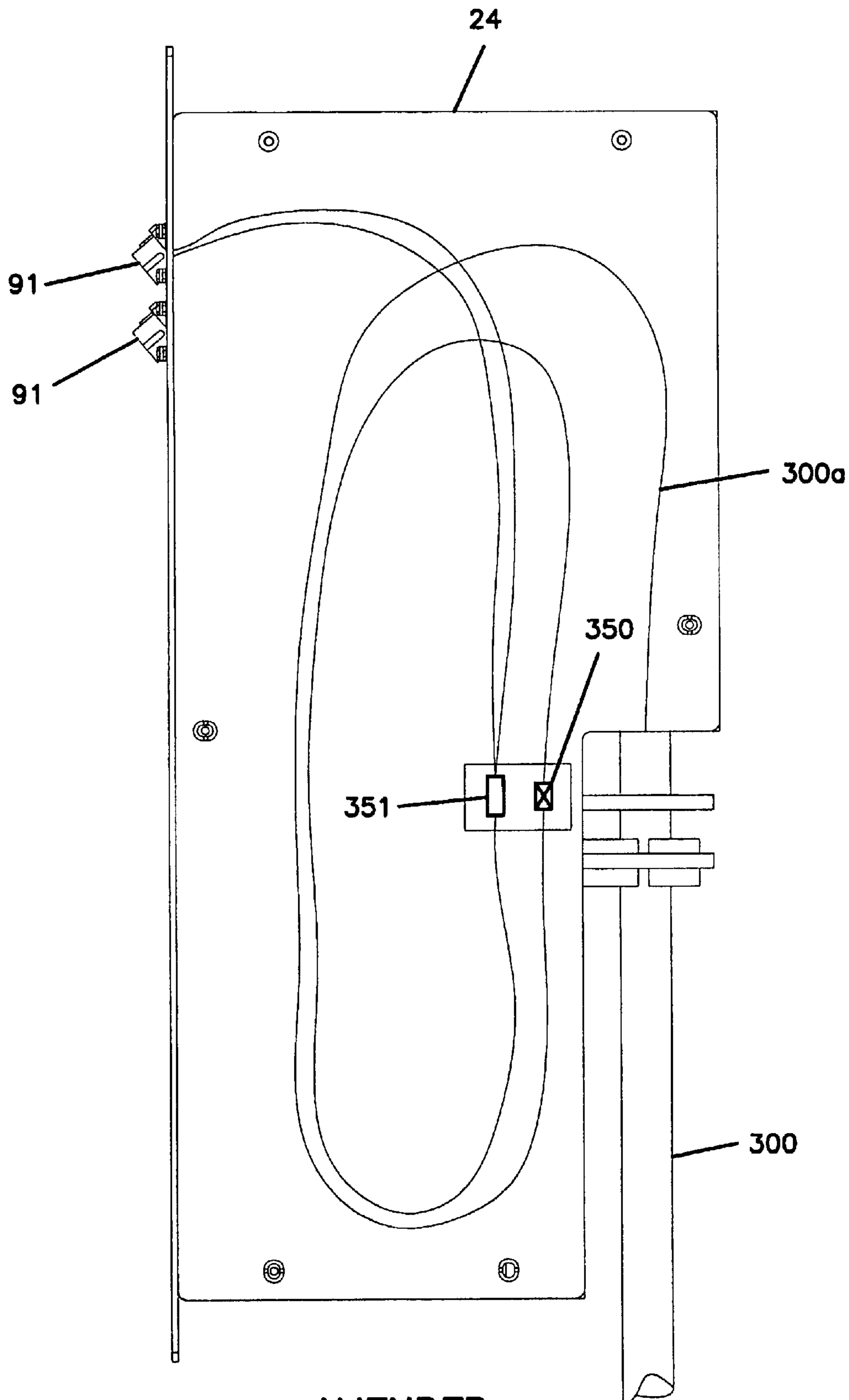
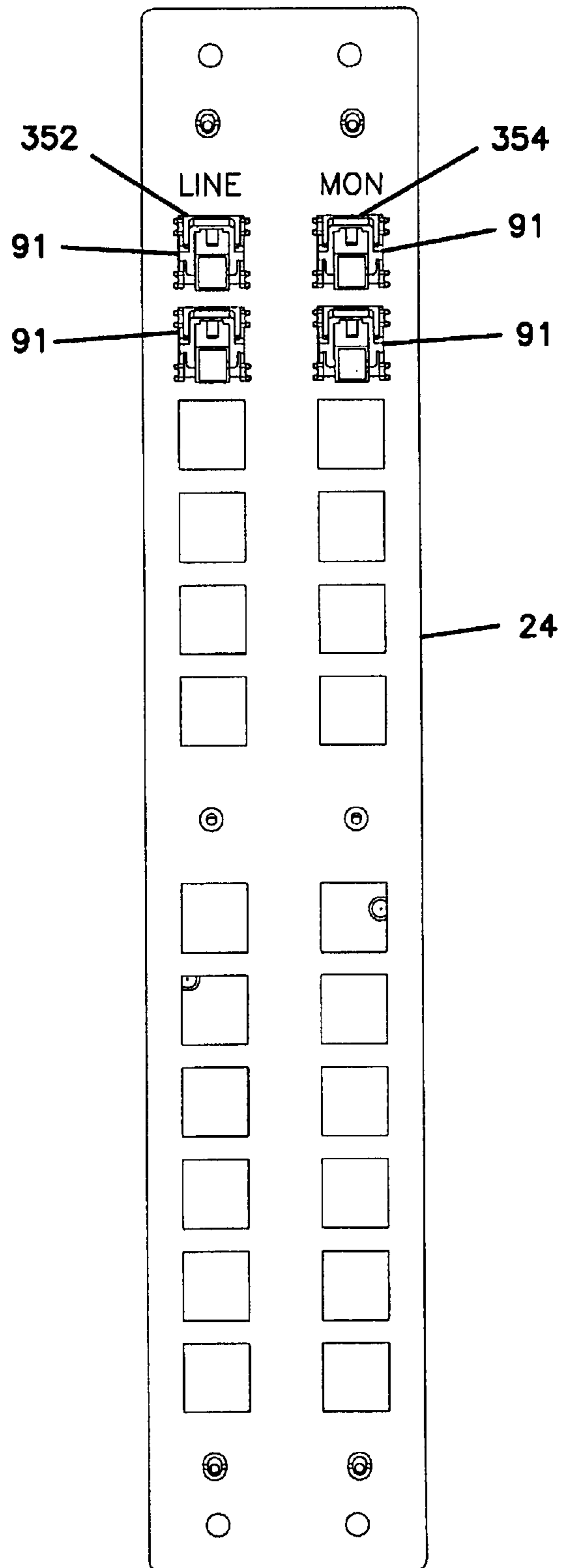

FIG. 13



AMENDED

FIG. 14



AMENDED

FIG. 15

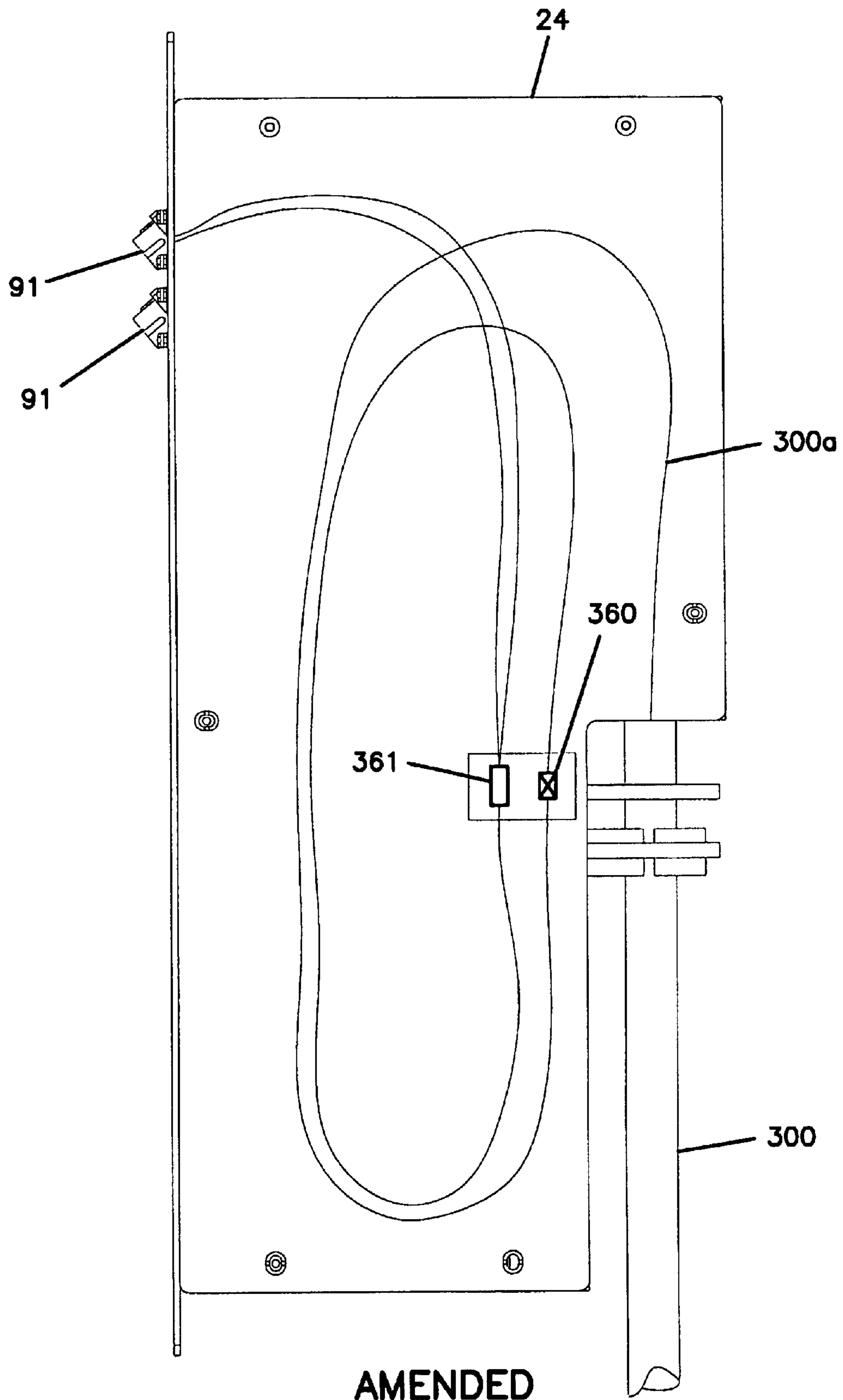
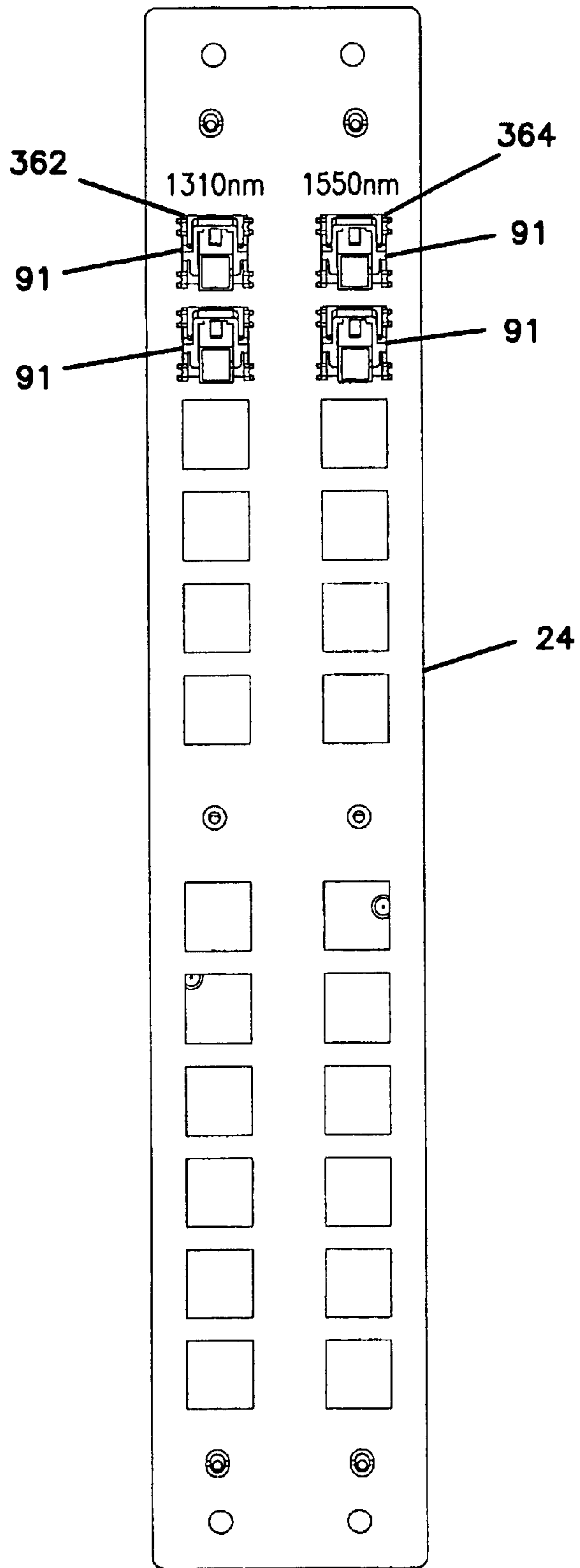

FIG. 16



AMENDED

FIG. 17

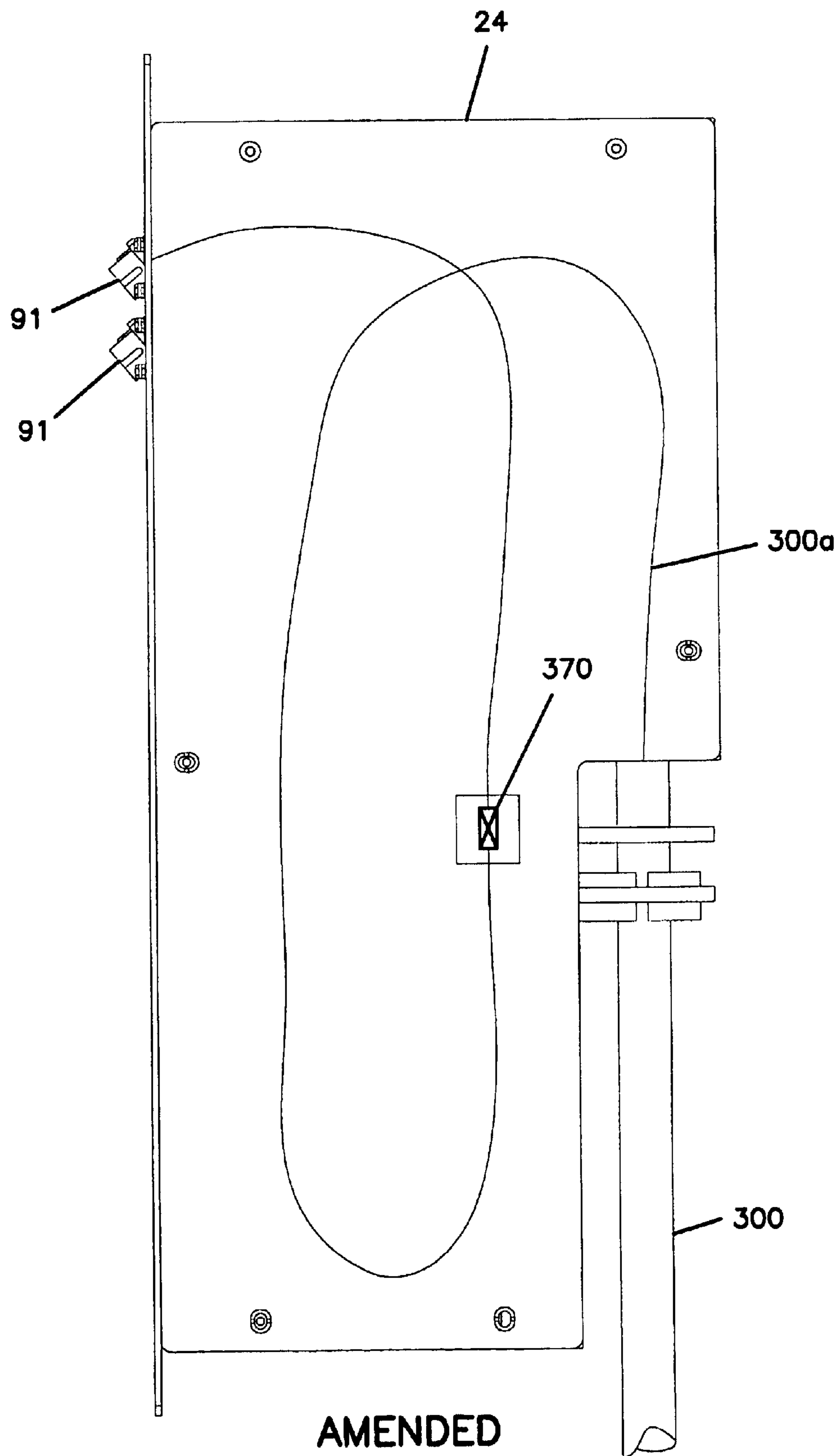
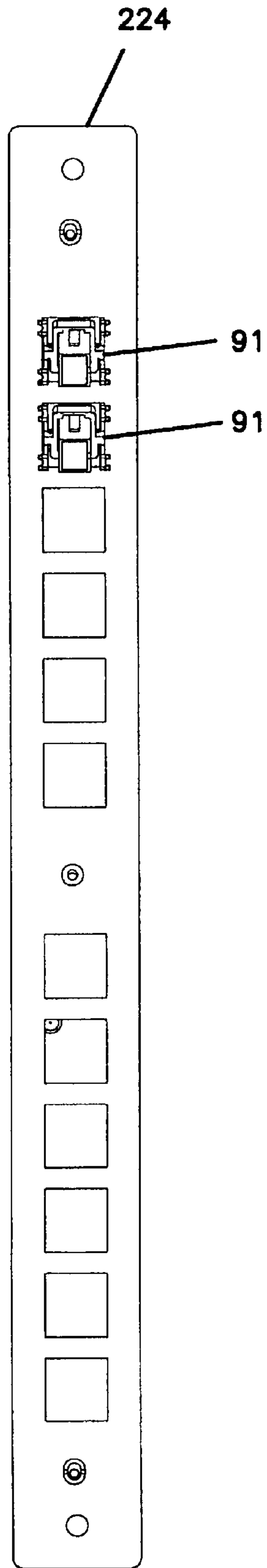
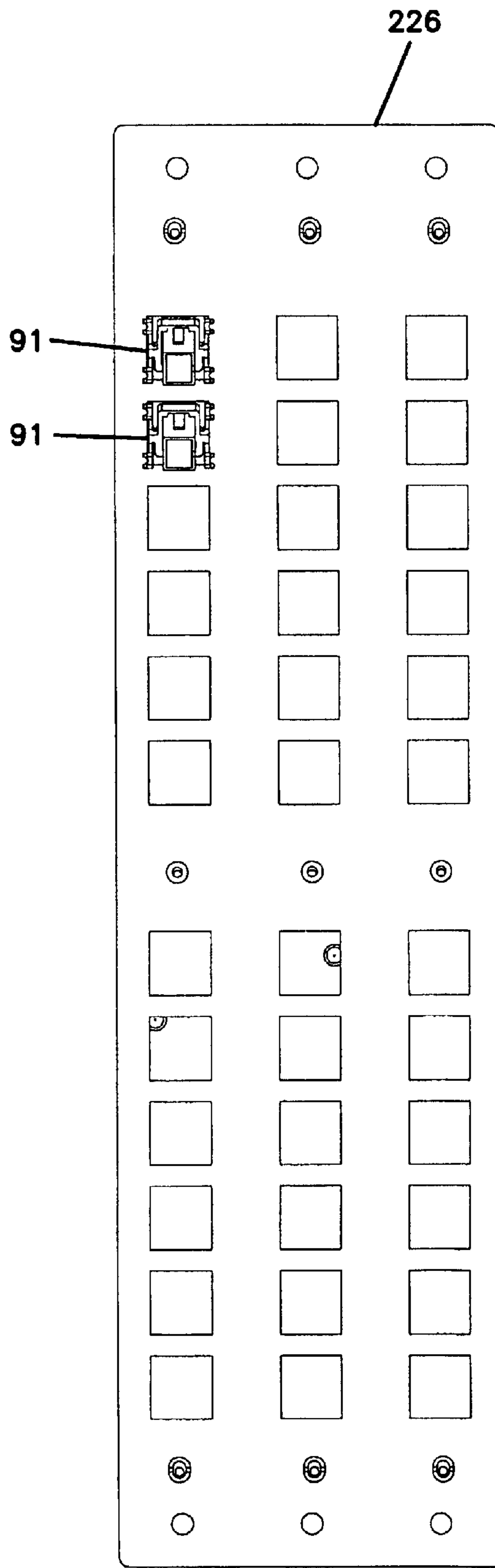

FIG. 18



AMENDED

FIG. 19



AMENDED

FIG. 20

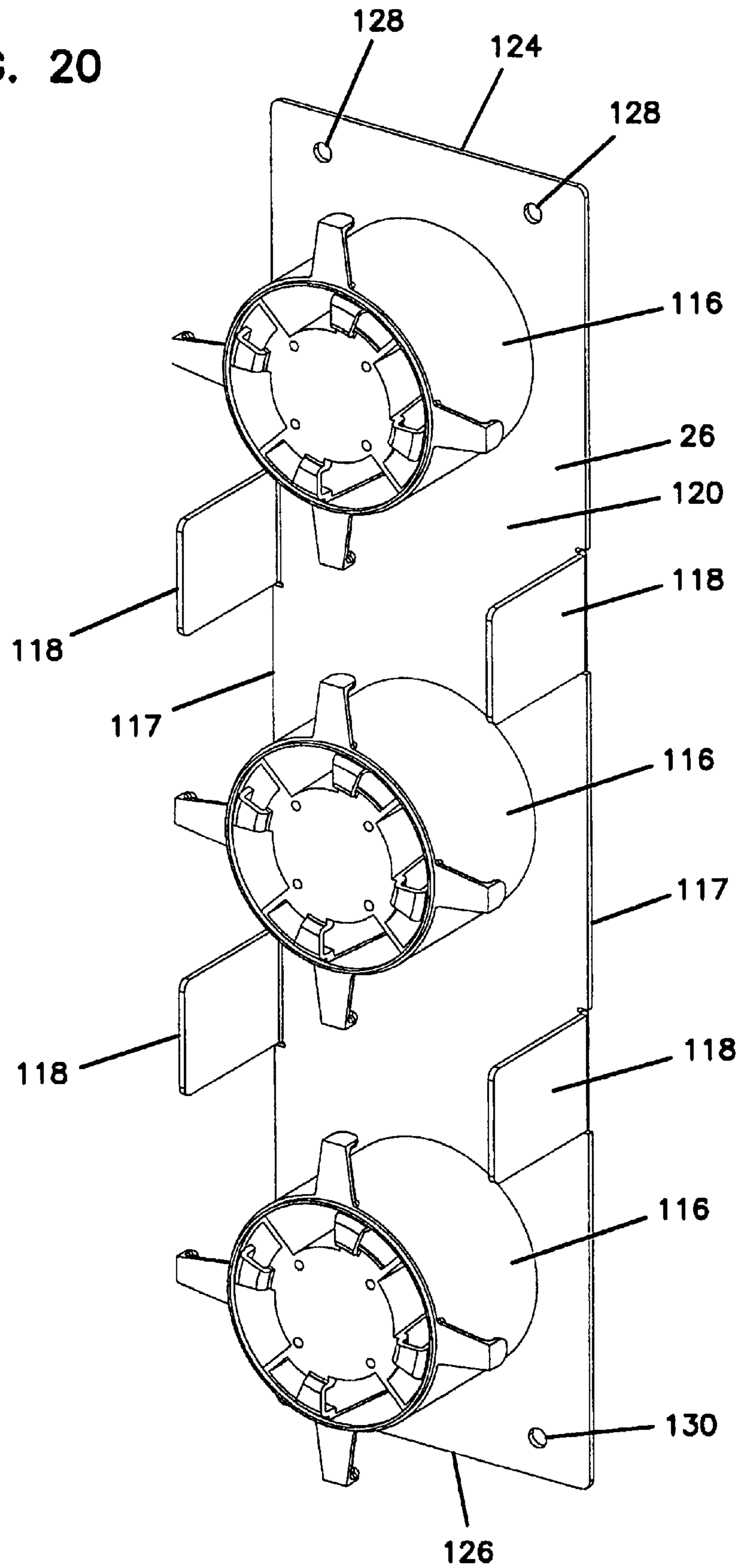

AMENDED

FIG. 21

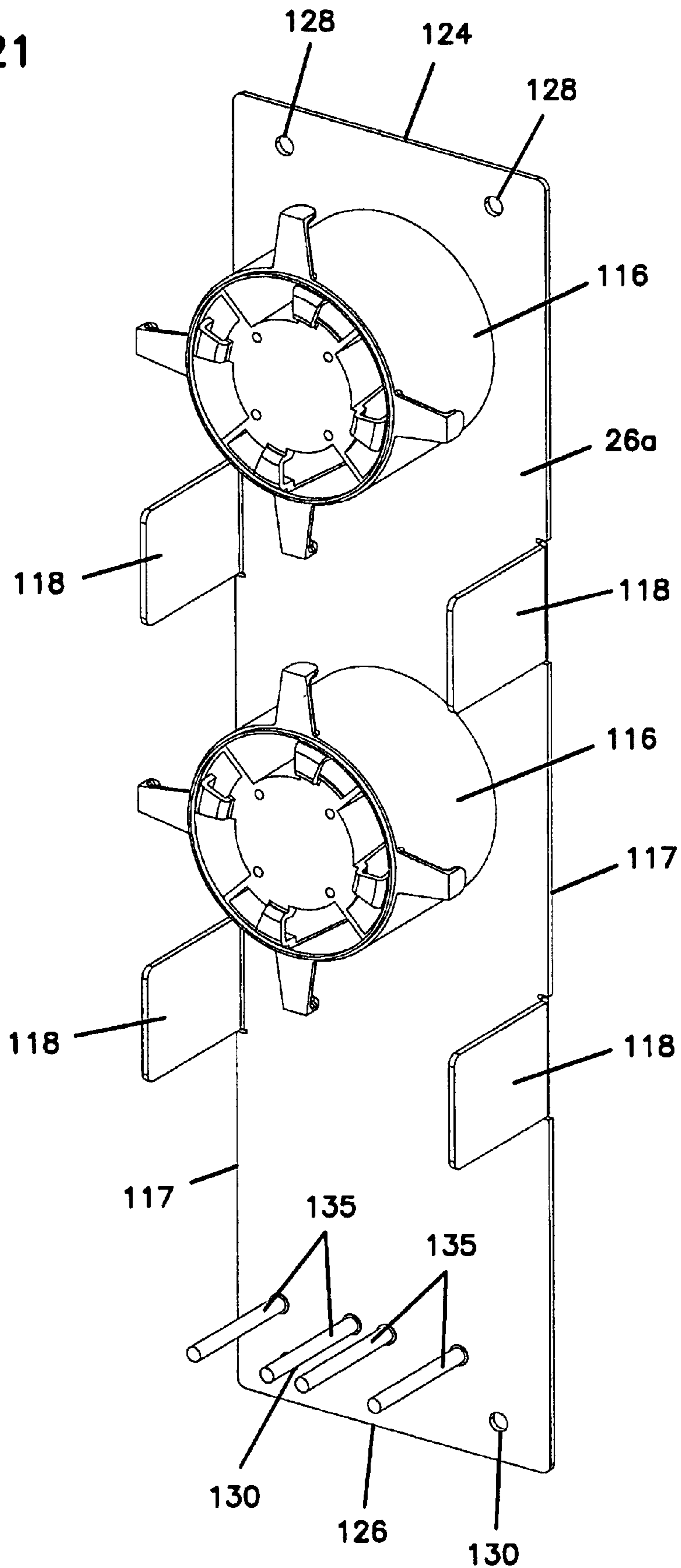

AMENDED

FIG. 22

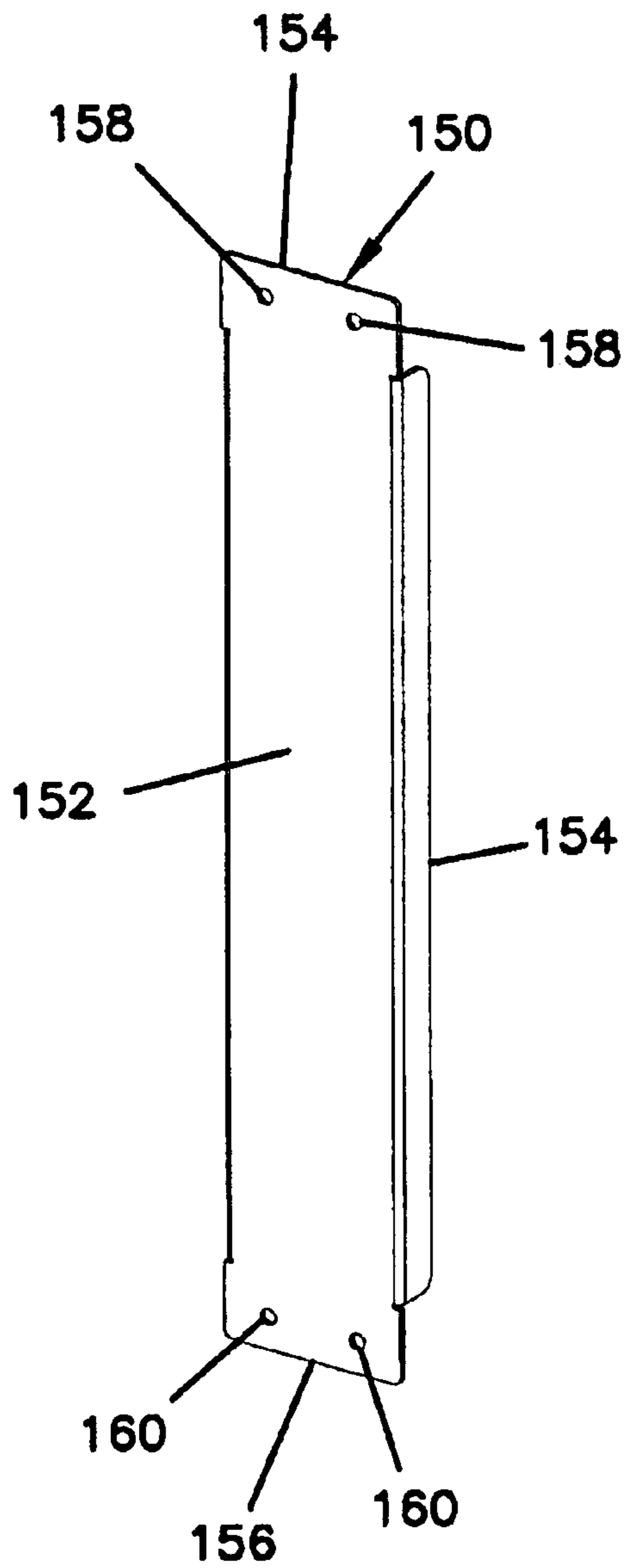

AMENDED

FIG. 23

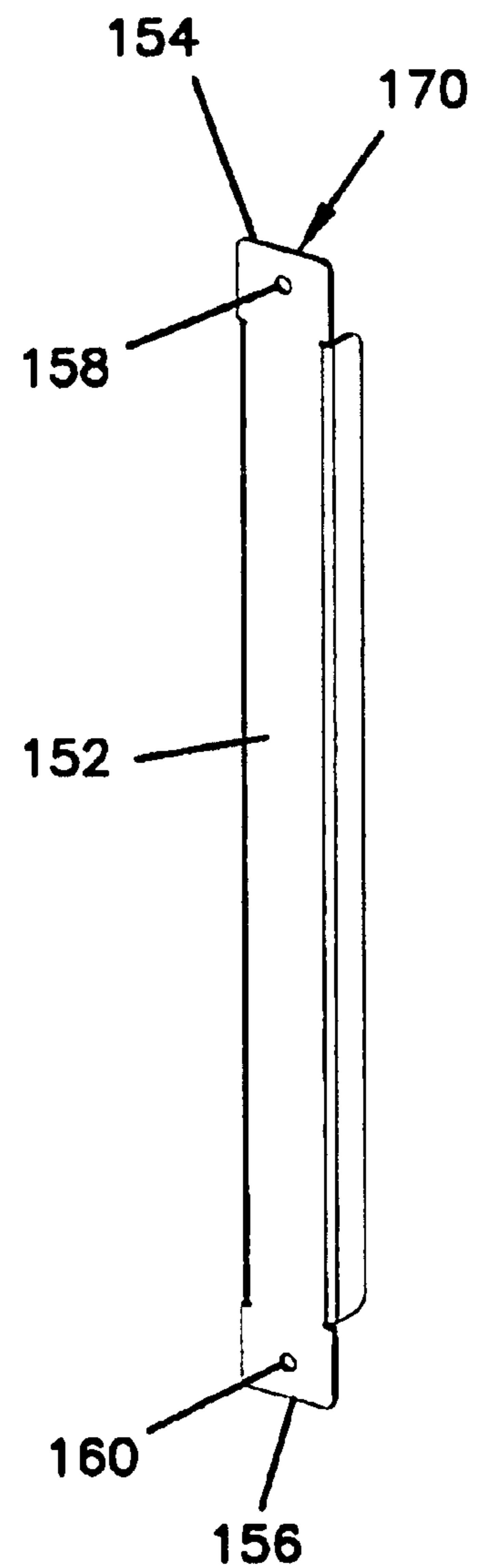

AMENDED

OUTSIDE PLANT FIBER DISTRIBUTION APPARATUS AND METHOD

Matter enclosed in heavy brackets [] appears in the original patent but forms no part of this reissue specification; matter printed in italics indicates the additions made by reissue.

CROSS-REFERENCE TO RELATED APPLICATIONS

Notice: More than one reissue application has been filed for the reissue of U.S. Pat. No. 6,363,200. The reissue patent applications include the present application; application Ser. No. 12/218,241, filed Jul. 11, 2008; application Ser. No. 11/397,885, filed Apr. 4, 2006; and application Ser. No. 10/810,547, filed Mar. 26, 2004, now U.S. Patent RE 40,358. The present application and application Ser. No. 12/218,241 are continuation reissue applications of application Ser. No. 11/397,885, which is a divisional reissue application of application Ser. No. 10/810,547, which is a reissue application of U.S. Pat. No. 6,363,200.

This application is a divisional of application Ser. No. 09/122,947, filed Jul. 27, 1998, now U.S. Pat. No. 6,160,946 which application is incorporated herein by reference.

FIELD OF THE INVENTION

This invention relates to an apparatus for housing fiber optic telecommunications equipment in outside plant environments. More particularly, this invention relates to an enclosure and management apparatus for housing cross-connect and/or interconnect equipment for fiber optic telecommunications systems. This invention also relates to modules for housing optical couplers such as optical splitters, wavelength division multiplexers.

BACKGROUND OF THE INVENTION

With the increased use of fiber optic technology in telecommunications, there is a need for apparatus which permit access to cross-connect functions and interconnect functions, while protecting the components in the field. For example, it is desirable to have access to fiber optic cables in outdoor locations such as contained within an enclosure adjacent to buildings which are linked at the enclosure to a feeder line.

In order to protect fiber optic connections from the environment and from damage due to impact or vandalism, such equipment is housed in enclosures which may be securably locked from unauthorized access. An example enclosure is shown in U.S. Pat. No. 5,734,776. The enclosure has a circular base, and a cylindrical shape. Enclosures with a more square shape are also known. Reltec (Reliable Electric) of Cleveland, Ohio sells a generally square enclosure, or pedestal, typically made of green colored metal, identified as CAD12. The Reltec CAD12 enclosure is generally about 12 inches by 12 inches at the base and about three to four feet high.

Providing cross-connect and/or interconnect functions within the enclosure is desired. Ease of assembly of the system and ease of access for later maintenance of the system are also desired. There is a need for further apparatus and methods for enclosing and managing outside plant equipment with cross-connect and interconnect functions. There is also a need for enclosing and managing fiber optic splice locations and optical couplers.

SUMMARY OF THE INVENTION

An optical fiber distribution frame apparatus includes a frame member having upper and lower module mounting

brackets and an interior. The upper and lower module mounting brackets are spaced apart to define a space for receipt of a plurality of fiber optic modules mounted to the frame member. Each module includes a front and two mounting flanges. Each mounting flange is mountable to one of the upper and lower module mounting brackets.

The modules are provided with one or more functions. One of the modules defines a connection module and further includes a rear spaced from the front, a spaced apart top and bottom positioned adjacent to the flanges, and spaced apart sides. The connection module is configured and arranged for housing a plurality of connection locations having exposed openings along the front arranged in one or more vertical arrays. The bottom, the rear, and the opposed sides of the connection module define a cable notch region, wherein the cable notch region includes an opening for a first cable to enter the module. The first cable is connectable to the connection locations within an interior of the connection module either directly or through optical couplers. A further module defines a storage module including first and second spools positioned on the front.

The connection locations preferably define adapters for connection to connectors of fiber optic cables. Preferably, the adapters are angled downwardly when the connection module is mounted to the frame member.

An enclosure is preferably provided to surround the frame member for use in an outside plant application. In the case of configuring the optical fiber distribution frame apparatus as an interconnect system, the storage module preferably includes a cable clamp positioned on the front for clamping a second cable, wherein the second cable is connectable to the connection locations on the connector module. The frame member preferably has a cable tray and an opening sized for receipt of the second cable. The interconnect system may also include a blank or filler module defining a generally planar front.

In the case of configuring the optical fiber distribution frame apparatus as a cross-connect system, two connection modules are provided, and the storage module is positioned between the two connection modules. One or more patch cords link the connection locations of the two connection modules.

The present invention also relates to a method of assembling an optical fiber distribution frame including the steps of providing a frame member, and selecting a plurality of fiber optic modules for mounting to the frame. The fiber optic modules are selected so as to fill the frame member with desired functions. Connection modules, storage modules, and blank or filler modules can be selected as desired. In the case of a cross-connect system, two connection modules are mounted to the frame member, with a storage module positioned between the two connection modules and mounted to the frame member in one embodiment. In the case of an interconnect system, a connection module is mounted to the frame member, as well as a storage module in another embodiment.

The present invention also relates to individual components comprising an optical fiber distribution frame apparatus. A frame member defines an interior, and includes an open front bounded by upper and lower module mounting brackets. The lower module mounting brackets further include a plurality of openings configured and arranged for receiving cable.

A connection module in accordance with the present invention includes a front and two mounting flanges. A rear of the module is spaced from the front. A top and bottom are

positioned adjacent to the flanges, and opposed spaced apart sides define an enclosed interior for the connection module. The connection module interior houses a plurality of connection locations having exposed openings along the front. The bottom, the rear, and the opposed sides define a cable notch region wherein the cable notch region defines an opening for receiving a first cable.

A storage module in accordance with the present invention includes a front and two mounting flanges, and first and second spools in alignment extending between the two mounting flanges. Side edges of the front further include projecting cable guides. In the case of a storage module for use in an interconnect system, a cable clamp is also positioned on the front for clamping a cable.

Blank or filler modules are also provided in accordance with the invention to fill unused space of the frame member. Each blank module includes a generally planar front, and two mounting flanges. Side flanges extend in an opposite direction to the direction faced by the front.

The connection module may house within its interior a splice between the first cable entering the module through the cable notch region, and the individual cables leading to the connection locations on the front of the module or to one or more optical couplers housed within the interior of the module. Example couplers include optical splitters and wavelength division multiplexers.

BRIEF DESCRIPTION OF THE DRAWINGS

FIG. 1 is a front view of a fiber distribution apparatus in a cross-connect configuration, with portions of the enclosure and the cover removed.

FIG. 2 is a front view of a fiber distribution apparatus in an interconnect configuration, With portions of the enclosure and the cover removed.

FIG. 3 shows the cross-connect fiber distribution apparatus of FIG. 1 including exemplary fibers in place.

FIG. 4 shows the interconnect fiber distribution apparatus of FIG. 1 including exemplary fibers in place.

FIG. 5 is an exploded perspective view of the frame and the cover.

FIG. 6 is a side view showing the cover mounted to the frame.

FIG. 7 is a front view of the frame.

FIG. 8 is a front view of a connection module, showing two exposed adapters for connecting to two connectors.

FIG. 9 is a side view of the connection module of FIG. 8, showing a first cable mounted to the rear in the cable notch and held by a cable clamp. Example individual fibers within the module are also shown schematically.

FIG. 10 shows the bottom of connection module in greater detail.

FIG. 11 is a perspective view of one of the front adapters held by a clip and connected to two connectors.

FIG. 12 shows in greater detail a portion of the front of the connection module with the adapters and clips.

FIG. 13 is a side view of a connection module like that shown in FIG. 9, and showing an exemplary fiber from the first cable linked to a splice, an optical splitter, and two front adapters, one from each vertical row.

FIG. 14 is a front view of the connection module of FIG. 13.

FIG. 15 is a side view of a connection module like that shown in FIG. 9, and showing an exemplary fiber from the first cable linked to a splice, a WDM, and two front adapters, one from each vertical row.

FIG. 16 is a front view of the connection module of FIG. 15.

FIG. 17 a side view of a connection module like that shown in FIG. 9, and showing an exemplary fiber from the first cable linked to a splice, and a front adapter.

FIG. 18 shows an alternative connection module to the module of FIG. 8 with one vertical row of adapters.

FIG. 19 shows a second alternative connection module with three vertical rows of adapters.

FIG. 20 is a perspective view of a cross-connect storage module.

FIG. 21 is a perspective view of an interconnect storage module.

FIG. 22 is a perspective view of a two-position blank module.

FIG. 23 is a one-position blank module.

DETAILED DESCRIPTION OF THE PREFERRED EMBODIMENTS

Referring now to FIGS. 1 and 3, a fiber distribution apparatus 10 is shown for use in cross-connect applications. FIGS. 2 and 4 show a similar fiber distribution apparatus 10' configured for interconnect applications. Both apparatus 10, 10' include an outer enclosure 20, and an inner frame 22 including a plurality of optical modules 23 mounted thereto. As will be described below in greater detail, modules 23 have particular functions, and apparatus 10, 10' is preferably provided with different modules 23 selected to have the desired functions for the particular application.

Enclosure 20 typically extends from the ground over underground cables 300, 302 (FIG. 3) and 400, 402 (FIG. 4) which extend upwardly from the ground and contain multiple individual optical fibers or bundles of fibers. Cables 300, 302, 400, 402 may be single cables or multiple cables. Enclosure 20 protects the inner components, in this case fiber optic telecommunications equipment. Enclosure 20 can be any convenient structure sized to protect frame 22 and modules 23. In the drawings, enclosure 20 includes a main vertical portion 40 extending from the ground and a top cap 42. Typically, a movable front door is provided, and a lock provides secure access.

Referring now to FIGS. 1-7, frame 22 is secured to main portion 40 of enclosure 20 along a rear side 41 of main portion 40. Frame 22 includes a base or bottom 50, and an opposed top 52. Frame 22 further includes a front 54, and an opposed rear 56, and spaced apart sides 58. Rear 56 of frame 22 can be screwed, riveted, or otherwise fastened to rear side 41 of main portion 40 of enclosure 20 through holes 62.

Frame 22 further includes an upper module mounting bracket 66, and a lower module mounting bracket 68 extending between sides 58. Each module mounting bracket 66, 68 receives a plurality of modules 23 connected via fasteners 70, such as screws, or other fasteners. Preferably, the fasteners are releasable to enable removal of modules 23, as desired, such as for repair, or replacement. Each of the module mounting brackets 66, 68 includes a plurality of holes 67, 69 for receipt of fasteners 70.

Lower module mounting bracket 68 defines a cable tray 60 (FIG. 5) including a plurality of lower holes 72, each sized for receipt of one or more cables, as will be described in greater detail below.

A cover 76 (FIGS. 5 and 6) mounts to frame 22 so as to close front 74. Side flanges 78 of cover 76 include a plurality of downwardly angled slots 80 for receipt of pins 82 extending from sides 58, 60 of frame 22. Nuts, such as wing nuts,

5

can be mounted to pins **82** with threads to help secure cover **76** to frame **22**.

Referring now to FIGS. **1–4**, and **8–12**, a connection module **24** is shown. Connection module **24** comprises one of modules **23**. Connection module **24** includes a front **90** defining a plurality of connection locations **91**. Front **90** also includes opposed mounting flanges **92, 94** extending along front **90** for mounting to module mounting brackets **66, 68** of frame **22**. Each of flanges **92, 94** includes a plurality of holes **96, 98** for receiving fasteners **70**. A spaced apart rear **100** of connection module **24**, and a spaced apart top **102** and bottom **104**, and opposed, spaced apart sides **106, 108** define an interior region. A cable notch **110** formed by portion of rear **100**, bottom **104**, and sides **106, 108** receives a cable **300** for connection to the connection locations **91** within the interior of module **24**. Notch **110** further includes an opening **112** for cable **300**. Opening **112** is large enough to receive one or more additional cables.

Each of the connection locations, **91** preferably includes an adapter **200** for mounting to a fiber optic connector, such as an SC (shown), an ST, an FC, or other connector. Cable **300** entering connector module **24** at opening **112** includes its individual fibers connected to the individual connection locations **91**, as desired. Two illustrated example fibers **300a, 300b** of cable **300** connect to two connection locations **91**. A connector **208** (FIG. **11**) is preferably on an end of fibers **300a, 300b**. Adapter **200** preferably has two ends **202** and **204**. End **202** is disposed within module **24** for connection to connector **208**. Opposite end **204** defines the exposed opening of the connection location **91** along the front of module **24** for connection to a second connector **218**. A clip **210**, such as the clip disclosed in U.S. Pat. No. 5,214,735 may be used to releasably attach each adapter to module **24**. Clip **210** also angles connection locations **91** downwardly when module **24** is installed in frame **22** as in the drawings. Each clip **210** holds each adapter **200** in one of the openings **93** of front **90** of module **24** to define each connection location in the preferred embodiment. In the illustrated embodiment of module **24**, only two connection locations **91** are shown, but a fully loaded module **24** would define a connection location **91** at each opening **93**. Clip **210** is preferably a snap mounted clip to enable easy assembly. A removable clip **210** is preferred to allow cleaning of connector **208** and end **202** if desired.

A similarly configured second connection module **24a** is mounted to frame **22** to permit cross-connection through the use of patch cords **114a, 114b** (FIG. **3**) to cross-connect between the fibers of each cable connected to the respective connection modules **24, 24a**. Cable **302** is connected to the rear of module **24a** as cable **300** is for module **24**. Patch cords **114a, 114b**, and fibers **300a, 300b** are shown schematically in FIGS. **3** and **9**, but each fiber has a connector like connectors **208, 218** to mate with adapter **200**. Alternatively, other connector systems as noted above can be used, as desired.

Each connection module **24, 24a** can be made of sheet metal sections, held together with fasteners, such as screws, so as to allow access as desired to the interior of each module.

To facilitate cable management, and cable protection, a cross-connect storage module **26** as one of modules **23** is provided having three spools **116** along a front **120** (FIGS. **1, 3** and **20**). Along a front **120** of an interconnect storage module **26a** as one of modules **23** is provided two spools **116** (FIGS. **2, 4** and **21**). Flanges **124, 126** permit mounting of each storage module **26, 26a** to frame **22** in a similar manner

6

as modules **24, 24a**. Holes **128, 130** receive fasteners **70** to mount storage modules **26, 26a** to frame **22**. Front projections **118** along vertical side edges **117** further enable cable management and cable protection during use. A cable clamp **134** (FIG. **4**) is provided for front mounting of one or more cables to storage module **26a** for the interconnect system. Posts **135** (FIG. **21**) hold the clamp pieces.

Cable notch **110** is useful to avoid excess cable bending during manipulation and positioning of connection modules **24**. The use of notch **110** provides a greater distance between the cables extending upward from the ground to the clamp mounting locations on modules **24**. The extra distance is advantageous when manipulating module **24** as it is installed into or removed from frame **22**.

In the example cross-connect system of FIG. **3**, two fibers **300a, 300b** (FIG. **9**) of cable **300** are shown as optically linked to two fibers of cable **302** through patch cords **114a, 114b** in a cross-connect application between modules **24, 24a**. In the example interconnect system of FIG. **4**, two fibers **402a, 402b** of cable **400** are shown as optically linked to two fibers of cable **400**.

Referring now to FIGS. **18** and **19**, alternative connection modules **224, 226** include different numbers of vertical rows of connector locations **91**. Modules **24, 24a** included two vertical rows. Connection module **224** includes a single row of connection locations **91**, and connection module **226** includes three. Four or more rows are also possible.

Referring now to FIGS. **13–17**, module **24** is shown as including optical components such as splices and/or optical couplers within the module between cable **300**, and connection locations **91**. In FIGS. **13** and **14**, a splice **350** to a one-by-two optical splitter **351** allows for module **24** to have line and monitor functions associated with connection locations **91**. Row **352** of connection locations **91** could serve as the line function, and row **354** could serve as the monitor function. Each pair of connection locations **91** (one from each row) would be linked to one of the fibers of cable **300** in FIG. **13**. Other splitters, such as one-by-fours, etc. may be used, as desired.

In FIGS. **15** and **16**, a splice **360** to a wave division multiplexer (WDM) **361** allows for module **24** to have wavelength division multiplexing functions associated with connection locations **91**. A “dense” wave division multiplexer may be used, if desired (DWDM). For the multiplexing function, row **362** of connection locations **91** could serve as the first wavelength ports, and row **364** could serve as the different wavelength ports. Each pair of connection locations **91** (one from each row) would be linked to one of the fibers of cable **300** in FIG. **15**.

FIG. **17** shows just a splicing component **370** so that each fiber of cable **300** could be spliced to a fiber leading to one connection location **91**. Other passive optical components can be selected as desired to provide module **24** with the desired function or functions.

Referring now to FIGS. **22** and **23**, blank panels **150, 170** comprising modules **23** are shown. Each blank panel **150, 170** includes a generally planar front **152**, and flanges **154** including holes **158, 160** to enable mounting of the blank modules **150, 170** to frame **22**. Blank modules **150, 170** are utilized to fill open spaces of frame **22**. Blank module **170** is a single width, and blank module **150** is a double width. Additional widths can be supplied as desired.

During assembly of a system for a particular outside plant application, the desired function (cross-connect, interconnect, other) is selected. The types of modules **23** (connection, storage, blank) and widths of modules **23** are

7

also selected. Further the types of connections and whether any optical splices or optical couplers are to be utilized are selected. The appropriate modules are selected and then mounted to frame 22 within an enclosure 20. Over time, the modules 23 can be removed for repair, replacement, or to change functions. Also, the front connections can be changed as the need arises.

The above specification, examples and data provide a complete description of the manufacture and use of the composition of the invention. Since many embodiments of the invention can be made without departing from the spirit and scope of the invention, the invention resides in the claims hereinafter appended.

What is claimed is:

[1. A connection module comprising:

a housing including a front and two mounting flanges, a rear of the housing spaced from the front, a top spaced apart from a bottom, the top and the bottom positioned adjacent to the mounting flanges, and opposed spaced apart sides;

a plurality of connection locations having exposed openings along the front;

the bottom, the rear, and the opposed sides defining a cable notch region wherein the cable notch region defines an opening for receiving a first cable; and

a cable clamp extending from the rear in the cable notch region.]

[2. The connection module of claim 1, wherein the connection locations include a plurality of adapters configured and arranged for connection to an optical fiber connector, the adapters positioned at an angle having a component angle in the direction of the bottom of the housing.]

[3. The connection module of claim 2, further comprising clips which are snap fit to the front of the housing, the clips each holding at least one adapter.]

[4. The connection module of claim 1, wherein the connection locations include a plurality of adapters, and further comprising a first cable connected to the housing by the clamp, and interior cables optically connected to the adapters, the interior cables optically connected to a splice, the splice optically connected to the first cable.]

[5. The connection module of claim 1, wherein the connection locations include a plurality of adapters, and further comprising a first cable connected to the housing by the clamp, and interior cables optically connected to the adapters, the interior cables optically connected to an optical coupler, the optical coupler optically connected to the first cable.]

[6. The connection module of claim 5, wherein the optical coupler includes a splitter.]

[7. The connection module of claim 5, wherein the optical coupler includes a wavelength division multiplexer.]

[8. The connection module of claim 6, further comprising a splice between the first cable and the splitter.]

[9. The connection module of claim 7, further comprising a splice between the first cable and the wavelength division multiplexer.]

10. An optical connection closure comprising:

a housing defining an enclosed interior;

at least one cable opening for receiving a portion of an outside plant cable within the interior of the housing;

a cable clamp that secures the outside plant cable relative to the housing at a clamp location, the cable clamp being positioned such that the outside plant cable extends away from the interior of the housing at the clamp location in a first direction;

8

at least one adapter located at an exterior wall of the housing, the adapter including a first end and a second end, the first end of the adapter receiving a first fiber optic connector from inside the interior of the housing, and the second end of the adapter being configured to receive a second fiber optic connector from outside the housing, the second end of the adapter at least partially facing toward the first direction in which the outside plant cable extends at the clamp location; and

at least one splice component positioned within the interior of the housing for splicing an optical fiber of the outside plant cable to an interior optical fiber routed within the interior of the housing from the splice component to the first fiber optic connector received within the first end of the adapter.

11. The optical connection closure of claim 10, wherein the outside plant cable is secured to an exterior of the housing.

12. The optical connection closure of claim 10, wherein the housing is deployed at an above ground location.

13. The optical connection closure of claim 10, further comprising a plurality of the adapters mounted at the exterior wall of the housing.

14. The optical connection closure of claim 10, wherein the outside plant cable is an underground cable.

15. An optical connection device comprising:

a housing defining an enclosed interior;

an outside plant cable secured to the housing at a securement location, the outside plant cable extending away from the interior of the housing at the securement location in a first direction, the outside plant cable including a plurality of optical fibers routed into the interior of the housing through an opening;

a plurality of adapters mounted to the housing, the adapters each including a first end and a second end, the first ends of the adapters receiving first fiber optic connectors from inside the interior of the housing, and the second ends of the adapters forming connection locations configured to receive second fiber optic connectors from outside the housing, the second ends of the adapters at least partially facing toward the first direction in which the outside plant cable extends at the securement location; and

interior optical fibers spliced to the optical fibers of the outside plant cable at splice locations within the interior of the housing, the interior optical fibers being routed within the interior of the housing from the splice locations to the first fiber optic connectors received within the first ends of the adapters.

16. The optical connection device of claim 15, wherein the outside plant cable is clamped to the housing.

17. The optical connection device of claim 15, wherein the outside plant cable is secured to an exterior of the housing.

18. The optical connection device of claim 15, wherein the housing is deployed at an above ground location.

19. The optical connection device of claim 15, wherein the outside plant cable is an underground cable.

20. An optical connection device comprising:

a housing defining an interior;

an outside plant cable secured to the housing at a securement location, the outside plant cable extending away from the interior of the housing at the securement location in a first direction, the outside plant cable including an optical fiber routed into the interior of the housing through an opening;

a plurality of adapters mounted to the housing, the adapters each including a first end and a second end, the first

ends of the adapters receiving first fiber optic connectors from inside the interior of the housing, and the second ends of the adapters forming connection locations configured to receive second fiber optic connectors from outside the housing, the second ends of the adapters at least partially facing toward the first direction in which the outside plant cable extends at the securement location; and

interior optical fibers optically coupled to the optical fiber of the outside plant cable by a splitter positioned within the interior of the housing, the interior optical fibers being routed within the interior of the housing from the splitter to the first fiber optic connectors received within the first ends of the adapters.

21. The optical connection device of claim 20, wherein the outside plant cable is clamped to the housing.

22. The optical connection device of claim 20, wherein the outside plant cable is secured to an exterior of the housing.

23. The optical connection device of claim 20, wherein the housing is deployed at an above ground location.

24. The optical connection device of claim 20, wherein the outside plant cable is an underground cable.

25. An optical connection device comprising:

a housing defining an enclosed interior;

an outside plant cable secured to the housing at a securement location, the outside plant cable extending away from the interior of the housing at the securement location in a first direction, the outside plant cable including a plurality of optical fibers;

a plurality of adapters mounted to the housing, the adapters each including a first end and a second end, the first ends of the adapters receiving first fiber optic connectors from inside the interior of the housing, and the second ends of the adapters forming connection locations configured to receive second fiber optic connectors from outside the housing, the second ends of the adapters at least partially facing toward the first direction in which the outside plant cable extends at the securement location; and

interior optical fibers spliced to the optical fibers of the outside plant cable, the interior optical fibers also being linked the first fiber optic connectors received within the first ends of the adapters.

26. The optical connection device of claim 25, wherein the outside plant cable is clamped to the housing.

27. The optical connection device of claim 25, wherein the outside plant cable is secured to an exterior of the housing.

28. The optical connection device of claim 25, wherein the housing is deployed at an above ground location.

29. The optical connection device of claim 25, wherein the outside plant cable is an underground cable.

30. An optical connection device comprising:

a housing defining an interior;

an outside plant cable secured to the housing at a securement location, the outside plant cable extending away from the interior of the housing at the securement location in a first direction, the outside plant cable including an optical fiber;

a plurality of adapters mounted to the housing, the adapters each including a first end and a second end, the first ends of the adapters receiving first fiber optic connectors from inside the interior of the housing, and the second ends of the adapters forming connection locations configured to receive second fiber optic connectors from outside the housing, the second ends of the adapters at least partially facing toward the first direc-

tion in which the outside plant cable extends at the securement location; and

interior optical fibers optically coupled to the optical fiber of the outside plant cable by a splitter, the interior optical fibers being linked to the first fiber optic connectors received within the first ends of the adapters.

31. The optical connection device of claim 30, wherein the outside plant cable is clamped to the housing.

32. The optical connection device of claim 30, wherein the outside plant cable is secured to an exterior of the housing.

33. The optical connection device of claim 30, wherein the housing is deployed at an above ground location.

34. The optical connection device of claim 30, wherein the outside plant cable is an underground cable.

35. An optical connection closure comprising:

a housing defining an enclosed interior;

at least one cable opening for receiving a portion of an outside plant cable within the interior of the housing;

a cable clamp that secures the outside plant cable relative to the housing at a clamp location, the cable clamp being positioned such that the outside plant cable extends from the cable clamp at the clamp location in a first direction;

at least one adapter located at an exterior wall of the housing, the adapter including a first end and a second end, the first end of the adapter receiving a first fiber optic connector from inside the interior of the housing, and the second end of the adapter being configured to receive a second fiber optic connector from outside the housing, the second end of the adapter facing in a second non-parallel direction relative to the first direction in which the outside plant cable extends at the clamp location; and

at least one splice component positioned within the interior of the housing for splicing an optical fiber of the outside plant cable to an interior optical fiber routed within the interior of the housing from the splice component to the first fiber optic connector received within the first end of the adapter.

36. The optical connection closure of claim 35, wherein the outside plant cable is secured to an exterior of the housing.

37. The optical connection closure of claim 35, wherein the housing is deployed at an above ground location.

38. The optical connection closure of claim 35, further comprising a plurality of the adapters mounted at the exterior wall of the housing.

39. The optical connection closure of claim 35, wherein the outside plant cable is an underground cable.

40. An optical connection device comprising:

a housing defining an enclosed interior;

an outside plant cable secured to the housing at a securement location, the outside plant cable extending from the securement location in a first direction, the outside plant cable including a plurality of optical fibers routed into the interior of the housing through an opening;

a plurality of adapters mounted to the housing, the adapters each including a first end and a second end, the first ends of the adapters receiving first fiber optic connectors from inside the interior of the housing, and the second ends of the adapters forming connection locations configured to receive second fiber optic connectors from outside the housing, the second ends of the adapters facing in a second non-parallel direction relative to the first direction in which the outside plant cable extends at the securement location; and

11

interior optical fibers spliced to the optical fibers of the outside plant cable at splice locations within the interior of the housing, the interior optical fibers being routed within the interior of the housing from the splice locations to the first fiber optic connectors received within the first ends of the adapters. 5

41. The optical connection device of claim 40, wherein the outside plant cable is secured to an exterior of the housing.

42. The optical connection device of claim 40, wherein the housing is deployed at an above ground location. 10

43. The optical connection device of claim 40, wherein the outside plant cable is an underground cable.

44. The optical connection device of claim 40, wherein the outside plant cable is clamped to the housing.

45. An optical connection device comprising:

a housing defining an interior;

an outside plant cable secured to the housing at a securement location, the outside plant cable extending from the securement location in a first direction, the outside plant cable including an optical fiber routed into the interior of the housing through an opening; 20

a plurality of adapters mounted to the housing, the adapters each including a first end and a second end, the first ends of the adapters receiving first fiber optic connectors from inside the interior of the housing, and the second ends of the adapters forming connection locations configured to receive second fiber optic connectors from outside the housing, the second ends of the adapters facing in a second non-parallel direction relative to the first direction in which the outside plant cable extends at the securement location; and 25

interior optical fibers optically coupled to the optical fiber of the outside plant cable by a splitter positioned within the interior of the housing, the interior optical fibers being routed within the interior of the housing from the splitter to the first fiber optic connectors received within the first ends of the adapters. 30

46. The optical connection device of claim 45, wherein the outside plant cable is clamped to the housing. 35

47. The optical connection device of claim 45, wherein the outside plant cable is secured to an exterior of the housing. 40

48. The optical connection device of claim 45, wherein the housing is deployed at an above ground location.

49. The optical connection device of claim 45, wherein the outside plant cable is an underground cable. 45

50. An optical connection device comprising:

a housing defining an enclosed interior;

an outside plant cable secured to the housing at a securement location, the outside plant cable extending from the securement location in a first direction, the outside plant cable including a plurality of optical fibers; 50

12

a plurality of adapters mounted to the housing, the adapters each including a first end and a second end, the first ends of the adapters receiving first fiber optic connectors from inside the interior of the housing, and the second ends of the adapters forming connection locations configured to receive second fiber optic connectors from outside the housing, the second ends of the adapters facing in a second non-parallel direction relative to the first direction in which the outside plant cable extends at the securement location; and

interior optical fibers spliced to the optical fibers of the outside plant cable, the interior optical fibers also being linked the first fiber optic connectors received within the first ends of the adapters.

51. The optical connection device of claim 50, wherein the outside plant cable is clamped to the housing. 15

52. The optical connection device of claim 50, wherein the outside plant cable is secured to an exterior of the housing.

53. The optical connection device of claim 50, wherein the housing is deployed at an above ground location. 20

54. The optical connection device of claim 50, wherein the outside plant cable is an underground cable.

55. An optical connection device comprising:

a housing defining an interior;

an outside plant cable secured to the housing at a securement location, the outside plant cable extending from the securement location in a first direction, the outside plant cable including an optical fiber; 25

a plurality of adapters mounted to the housing, the adapters each including a first end and a second end, the first ends of the adapters receiving first fiber optic connectors from inside the interior of the housing, and the second ends of the adapters forming connection locations configured to receive second fiber optic connectors from outside the housing, the second ends of the adapters facing in a second non-parallel direction relative to the first direction in which the outside plant cable extends at the securement location; and 30

interior optical fibers optically coupled to the optical fiber of the outside plant cable by a splitter, the interior optical fibers being linked to the first fiber optic connectors received within the first ends of the adapters. 35

56. The optical connection device of claim 55, wherein the outside plant cable is clamped to the housing. 40

57. The optical connection device of claim 55, wherein the outside plant cable is secured to an exterior of the housing.

58. The optical connection device of claim 55, wherein the housing is deployed at an above ground location.

59. The optical connection device of claim 55, wherein the outside plant cable is an underground cable. 45

* * * * *