



US00RE42156E

(19) **United States**
(12) **Reissued Patent**
Hirota et al.

(10) **Patent Number:** **US RE42,156 E**
(45) **Date of Reissued Patent:** **Feb. 22, 2011**

(54) **EXHAUST EMISSION CONTROL SYSTEM OF AN INTERNAL COMBUSTION ENGINE**

(75) Inventors: **Shinya Hirota**, Susono (JP); **Toshiaki Tanaka**, Numazu (JP); **Satoshi Iguchi**, Mishima (JP); **Shunsuke Toshioka**, Susono (JP)

(73) Assignee: **Toyota Jidosha Kabushiki Kaisha**, Toyota-shi (JP)

(21) Appl. No.: **10/410,386**

(22) Filed: **Apr. 10, 2003**

5,388,406 A *	2/1995	Takeshima et al.	60/288
5,390,492 A *	2/1995	Levendis	60/288
5,398,503 A *	3/1995	Danno et al.	60/288
5,517,820 A *	5/1996	Kuroda et al.	60/274
5,768,888 A *	6/1998	Matros et al.	60/274
6,314,722 B1 *	11/2001	Matros et al.	60/274
6,568,178 B2 *	5/2003	Hirota et al.	60/297

FOREIGN PATENT DOCUMENTS

EP	0 580 398 A1	1/1994
EP	0 702 134 A2	3/1996
JP	A 6-173652	6/1994
JP	6173652 A	6/1994
JP	A 7-259542	10/1995
JP	7259542 A	10/1995

* cited by examiner

Primary Examiner—Tu M Nguyen

(74) *Attorney, Agent, or Firm*—Kenyon & Kenyon LLP

Related U.S. Patent Documents

Reissue of:

(64) Patent No.: **6,212,885**
Issued: **Apr. 10, 2001**
Appl. No.: **09/300,686**
Filed: **Apr. 27, 1999**

(51) **Int. Cl.**
F01N 3/00 (2006.01)

(52) **U.S. Cl.** **60/288**; 60/274; 60/285;
60/287; 60/296; 60/297; 60/324

(58) **Field of Classification Search** 60/274,
60/276, 277, 285, 286, 287, 288, 296, 297,
60/300, 302, 303, 324

See application file for complete search history.

(57) **ABSTRACT**

An exhaust emission control system of an internal combustion engine desorbs SO_x by reversing a flow of an exhaust gas through an NO_x storage-reduction catalyst, of which a structure is simplified as follows. A first exhaust pipe connected to an engine is connected to a first port of an emission switching valve having four ports. A second exhaust pipe 10, through which the exhaust gas is discharged into the atmospheric air, is connected to a second port, a third exhaust pipe connected to an inlet of a catalytic converter is connected to a third port. A fourth exhaust pipe connected to an outlet of the catalytic converter 30 is connected to a fourth port. When the emission switching valve is set in a forward flow position, the first exhaust pipe is connected to the third exhaust pipe, and the second exhaust pipe is connected to the fourth exhaust pipe, whereby the exhaust gas flows toward the outlet from the inlet within the catalytic converter. When the emission switching valve is set in a backward flow position, the first exhaust pipe is connected to the fourth exhaust pipe, and the second exhaust pipe is connected to the third exhaust pipe, whereby the exhaust gas flows toward the inlet from the outlet within the catalytic converter.

(56) **References Cited**

U.S. PATENT DOCUMENTS

2,898,202 A *	8/1959	Eriksson et al.	422/115
2,946,651 A *	7/1960	Houdry	423/212
3,072,457 A *	1/1963	Bloch	60/288
3,867,508 A *	2/1975	Hass	423/213.7
4,875,336 A *	10/1989	Hayashi et al.	60/286
5,123,243 A *	6/1992	Baddour	60/274
5,140,811 A *	8/1992	Minami et al.	60/288
5,233,830 A *	8/1993	Takeshima et al.	60/288
5,305,602 A *	4/1994	Kojima et al.	60/286
5,331,809 A *	7/1994	Takeshima et al.	60/288
5,349,816 A *	9/1994	Sanbayashi et al.	60/277

17 Claims, 29 Drawing Sheets

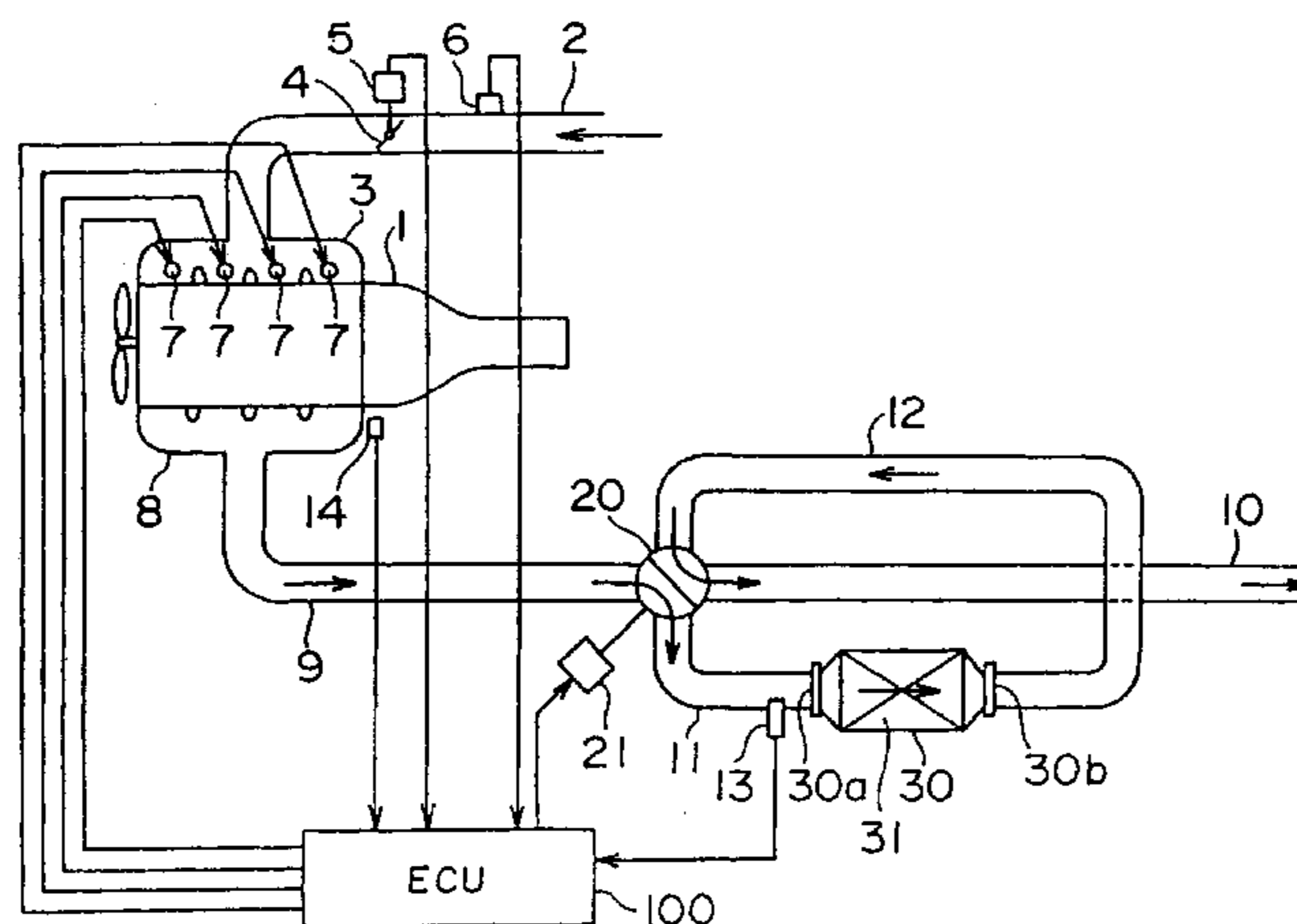

FIG.1

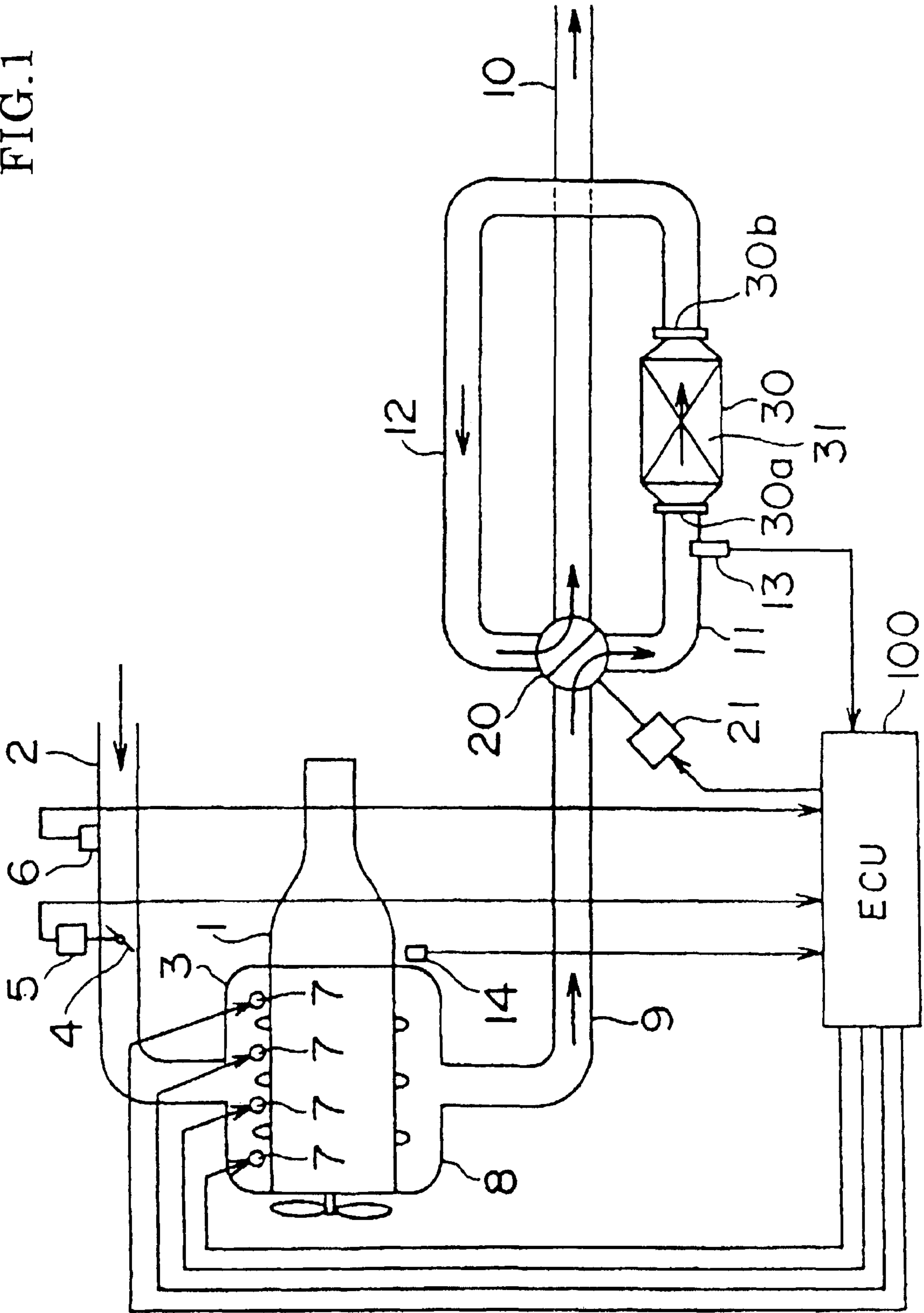

FIG. 2

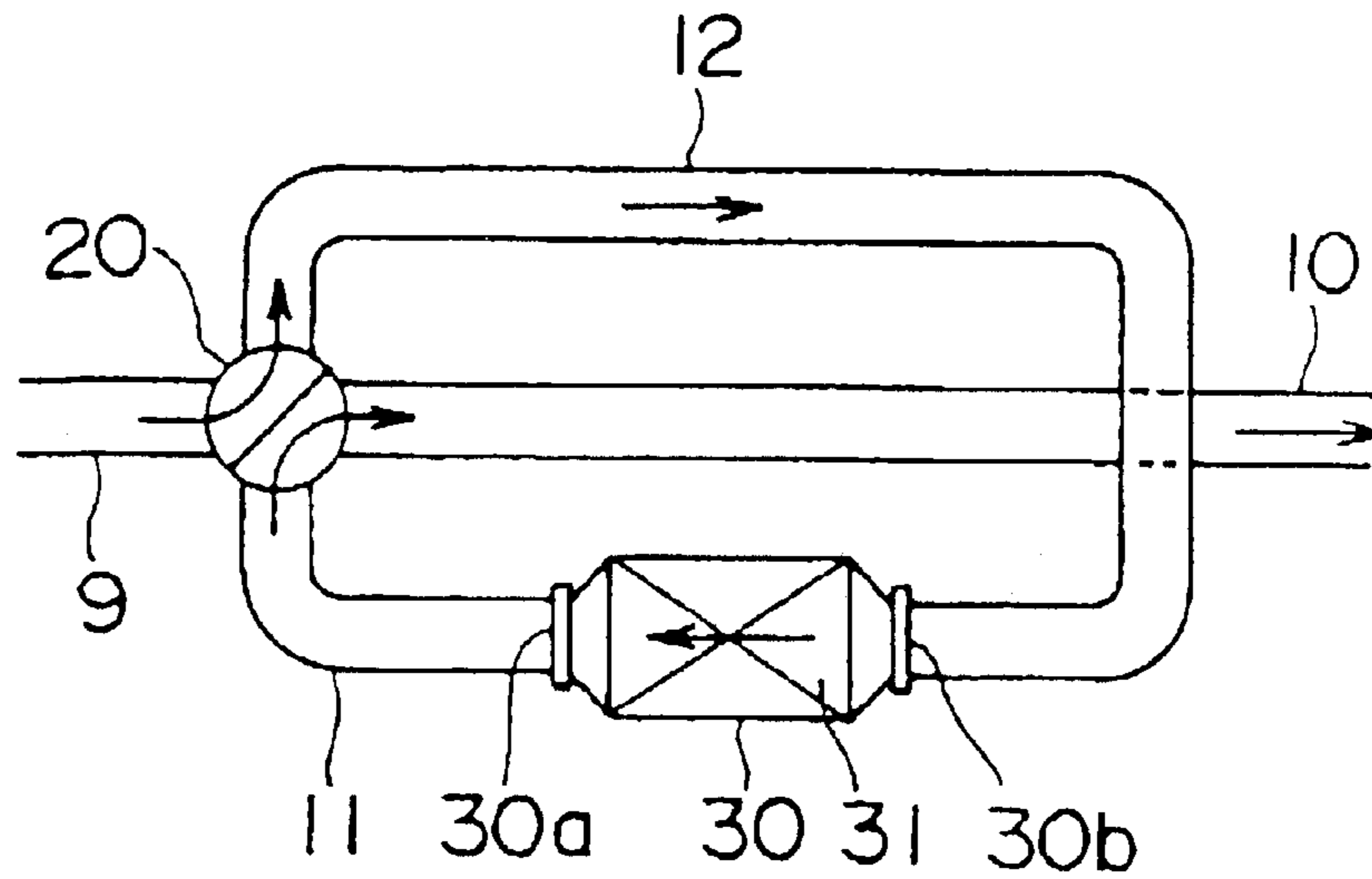

FIG. 3

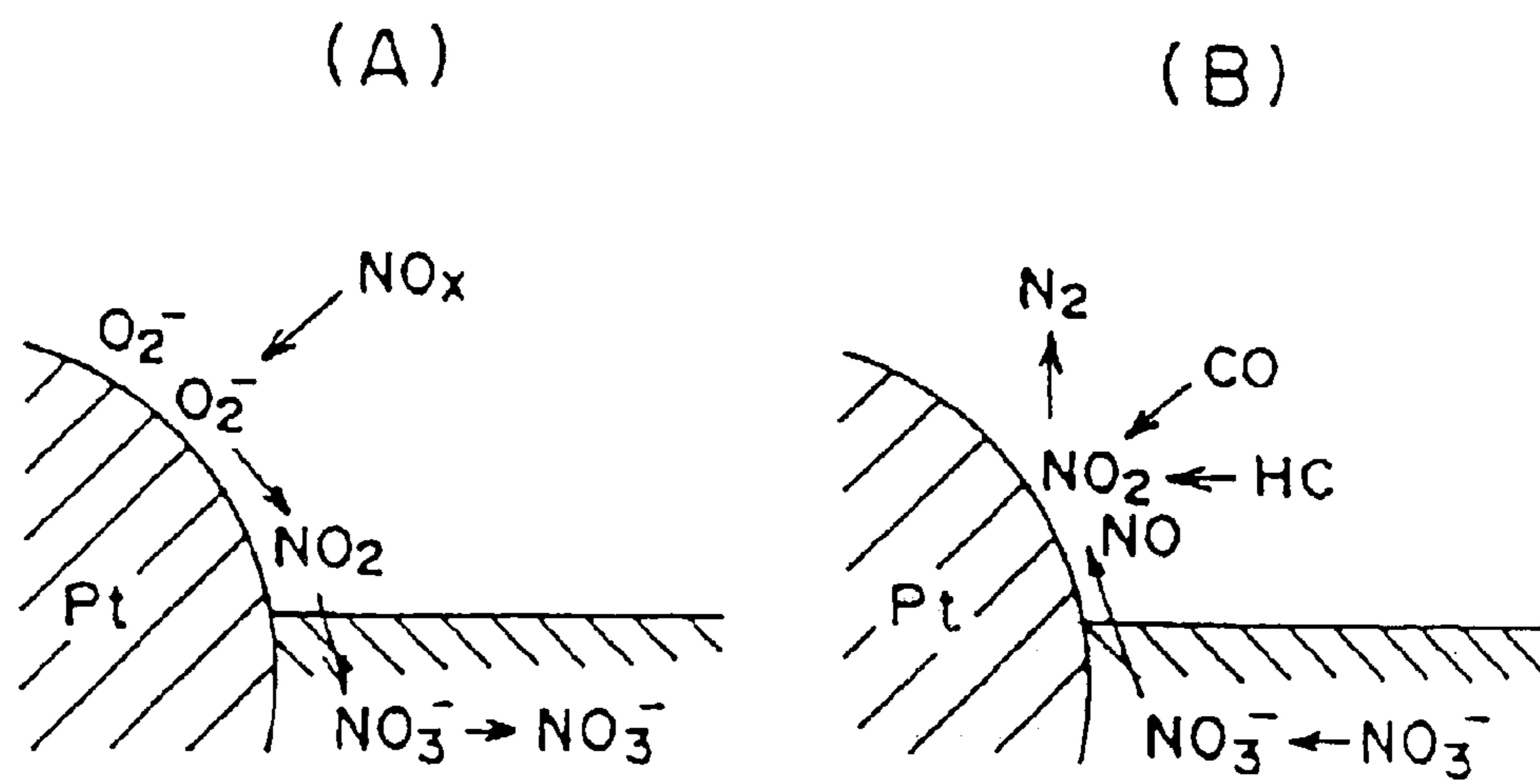

FIG. 4

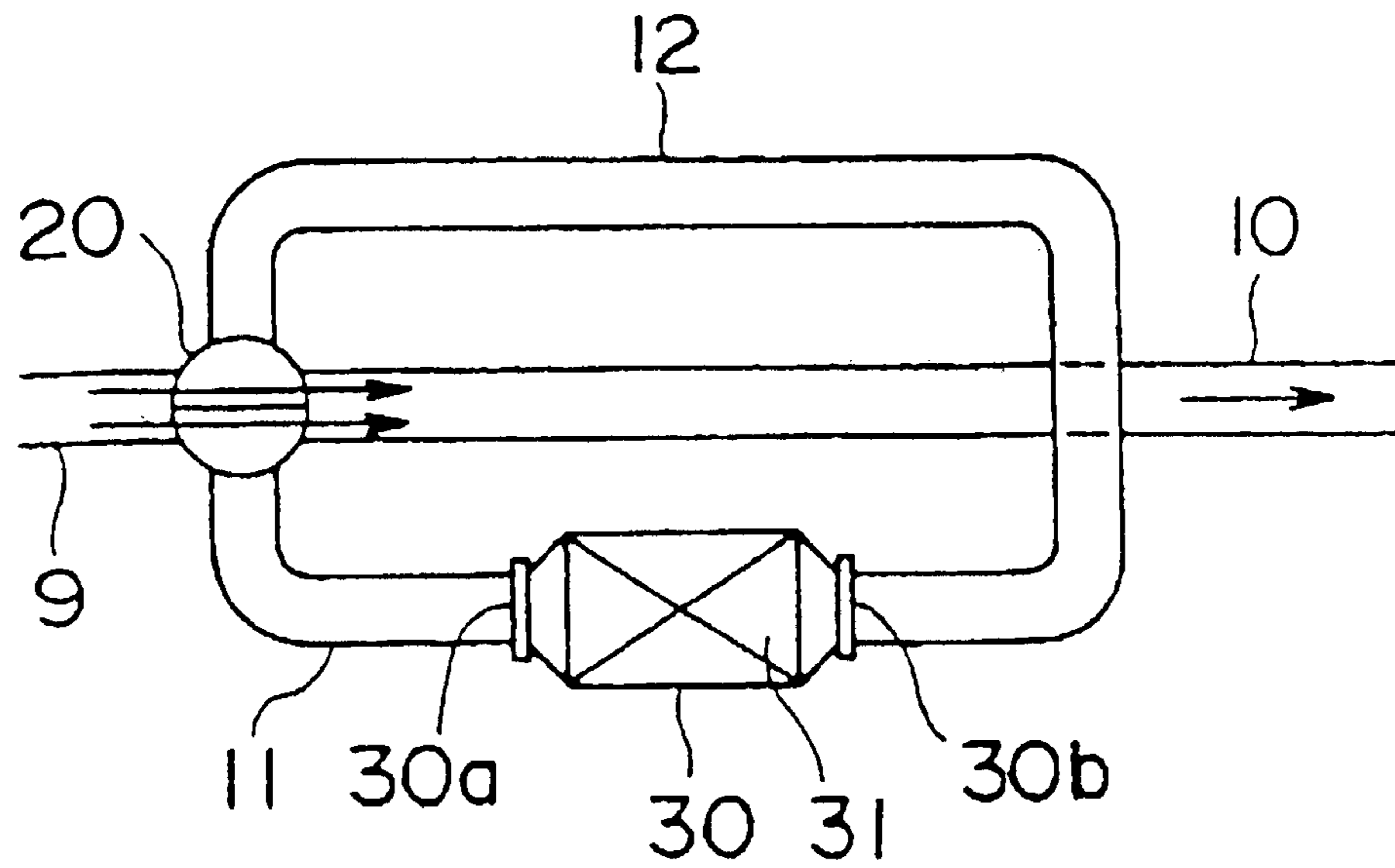

FIG. 5

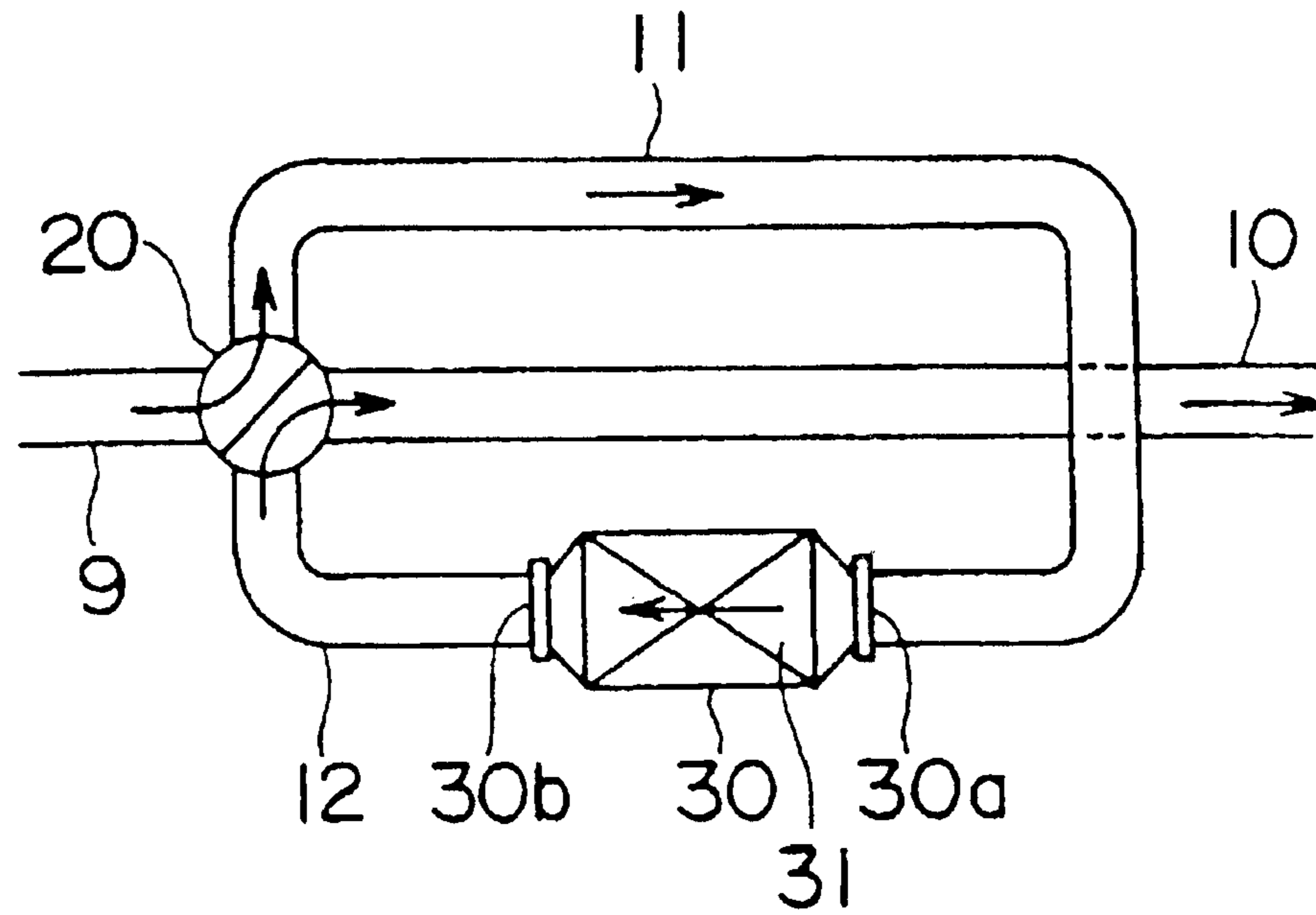

FIG.6

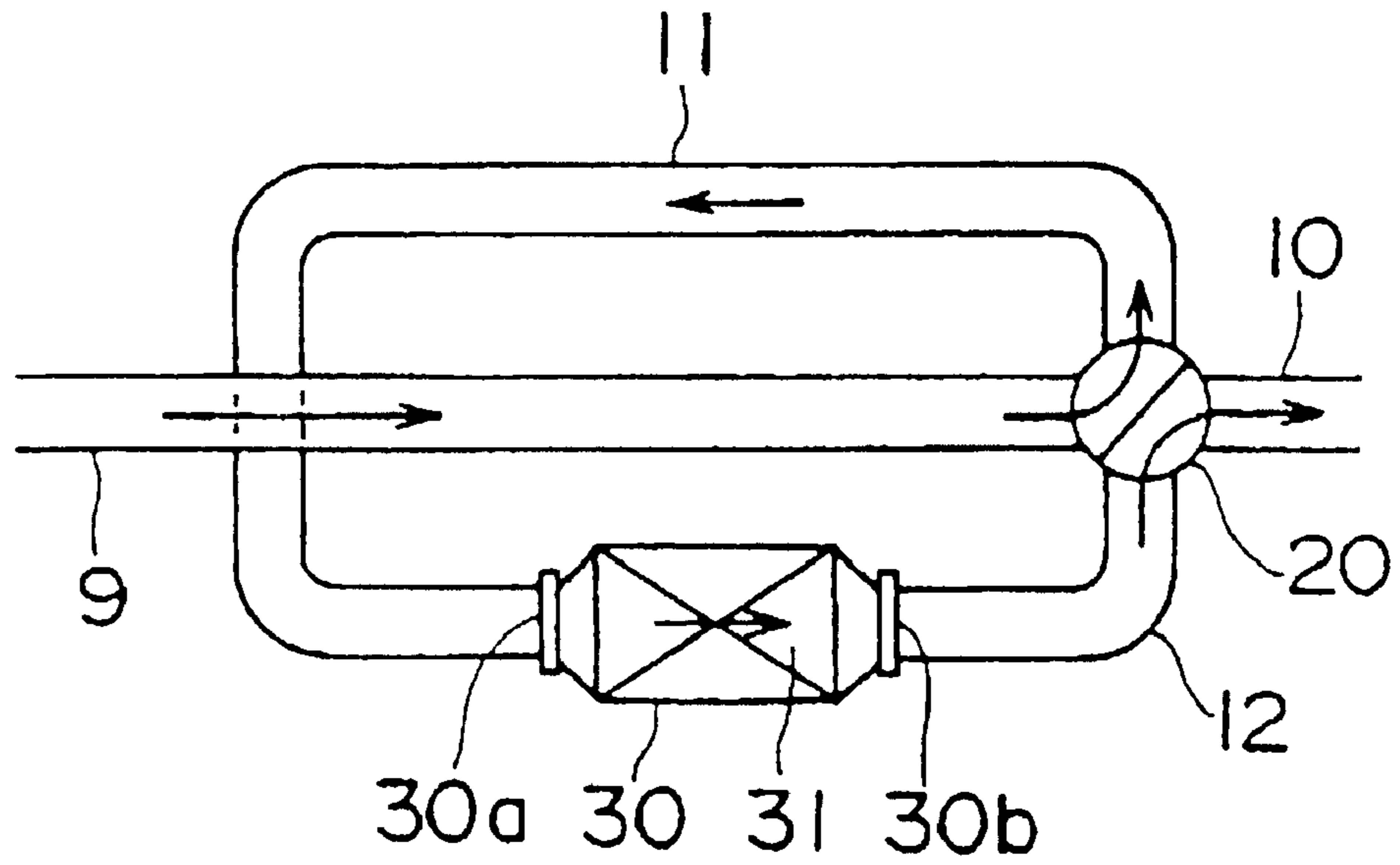

FIG.7

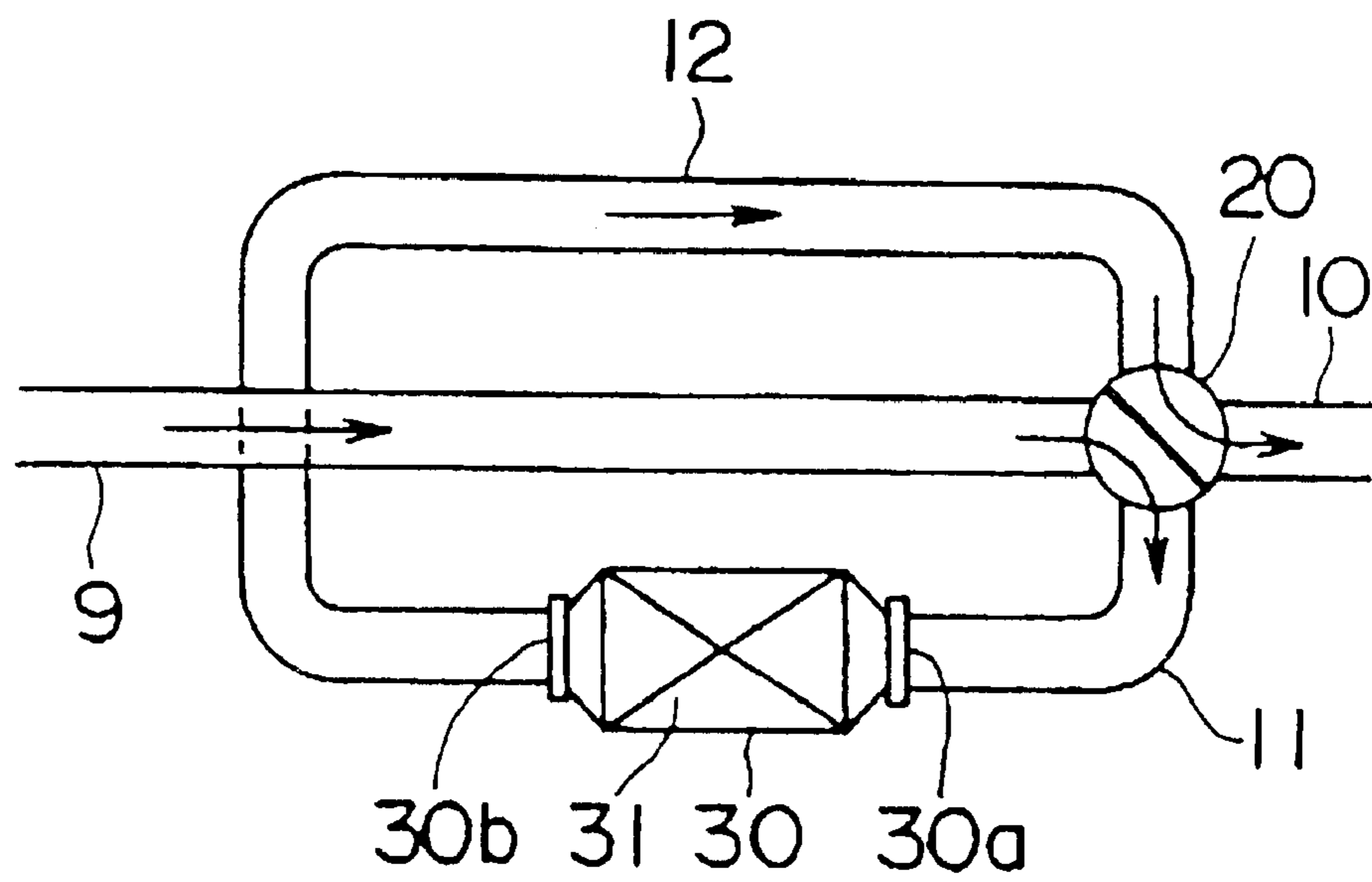

FIG. 8

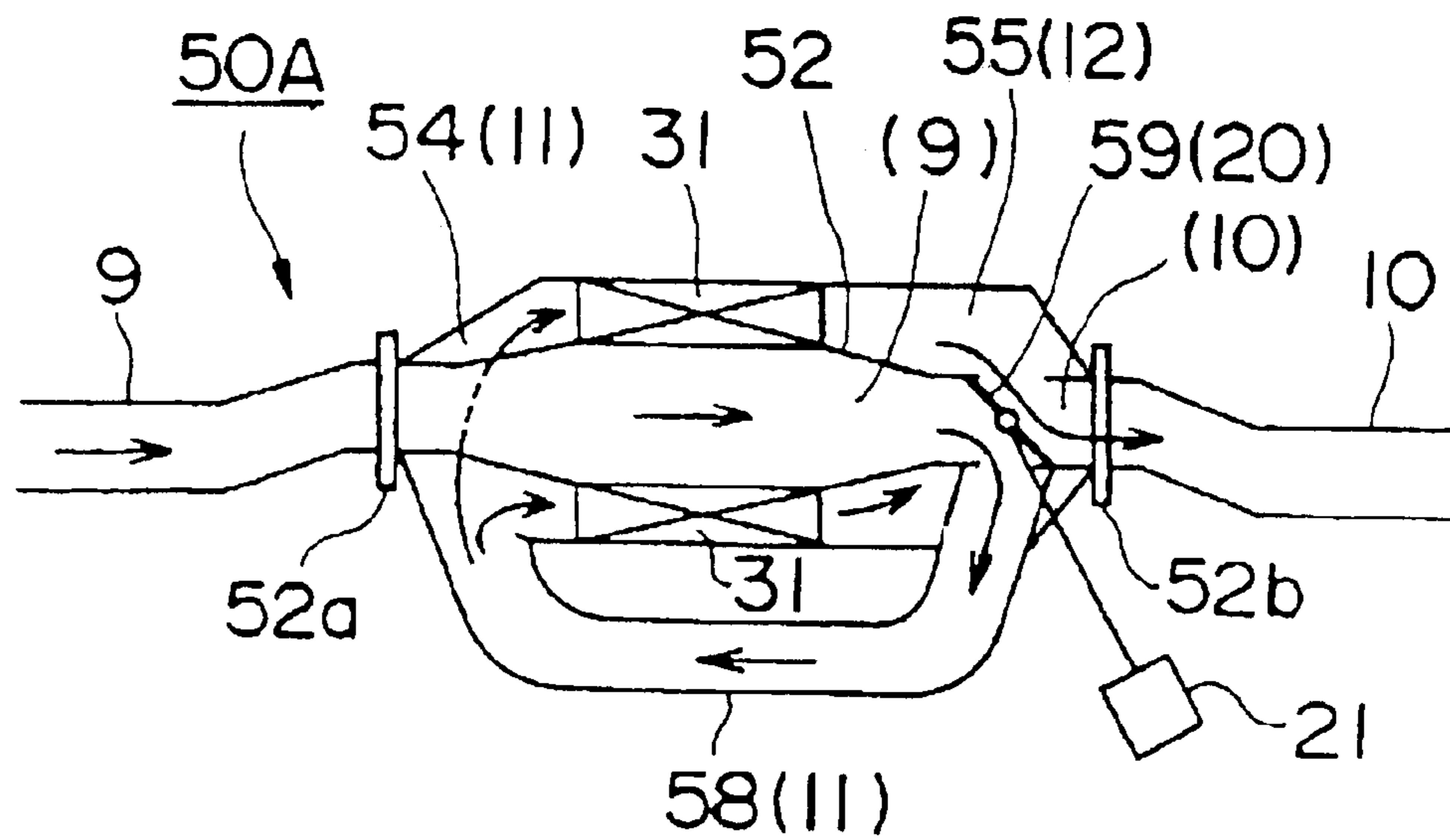

FIG. 9

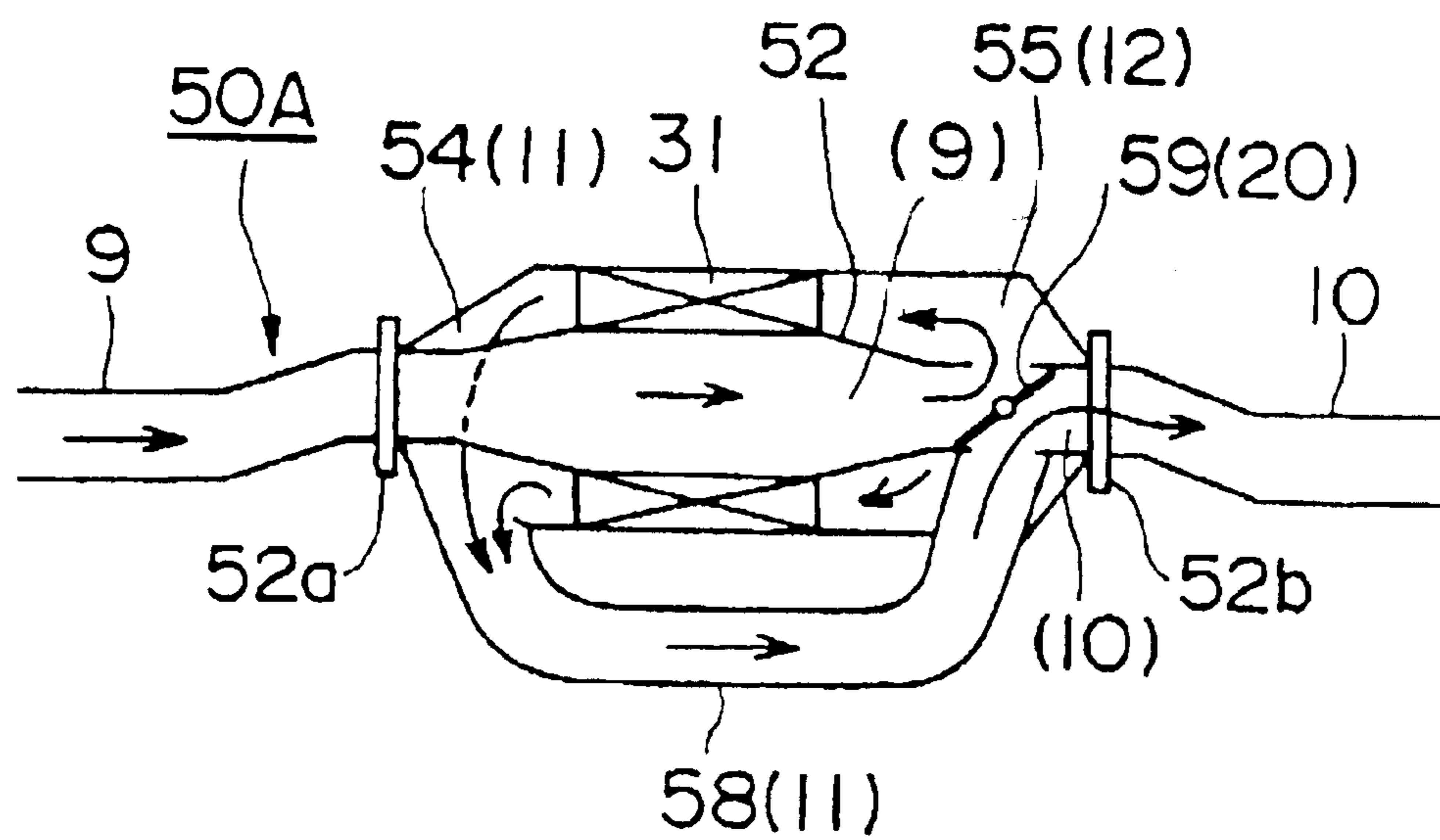

FIG. 10

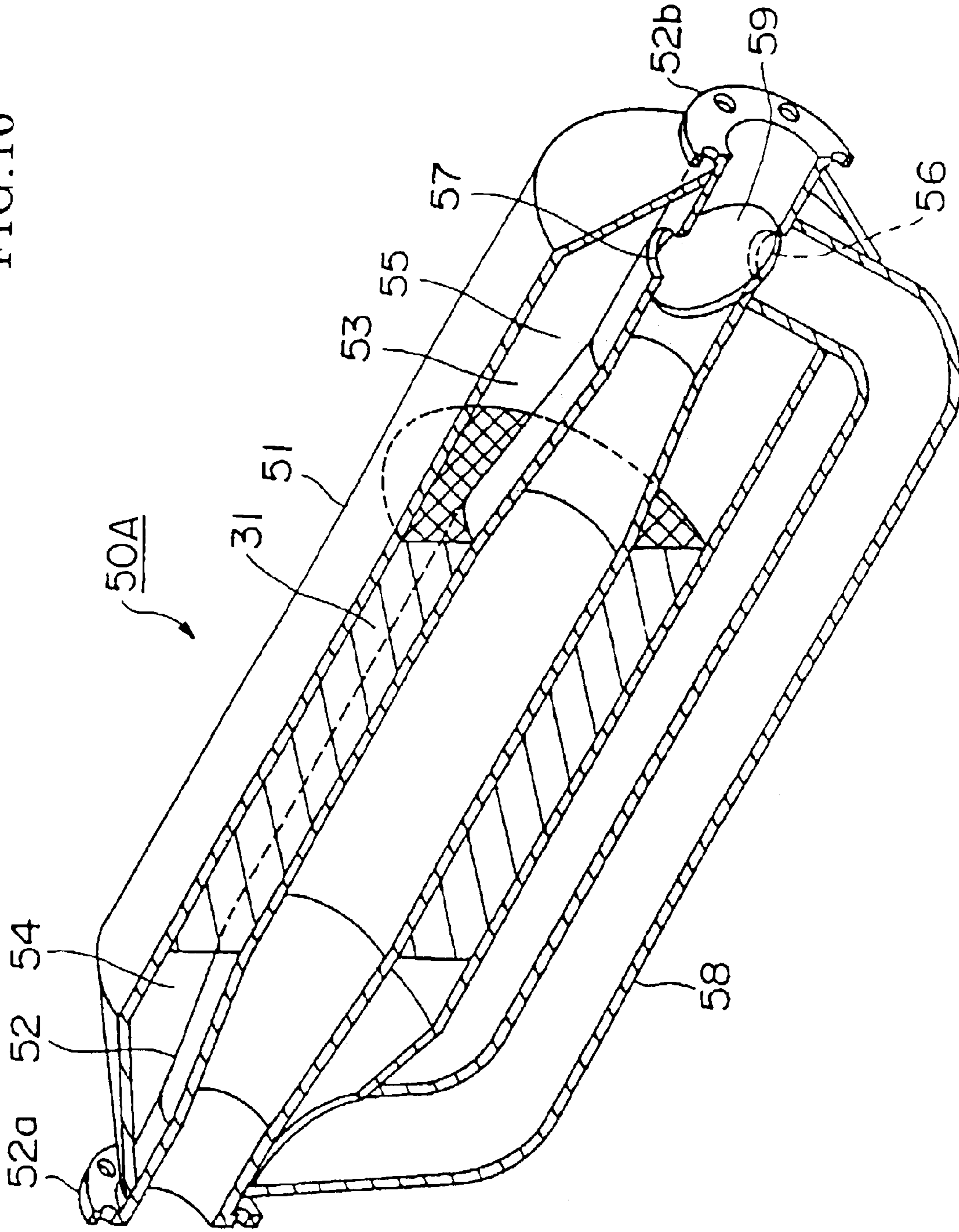

FIG.11

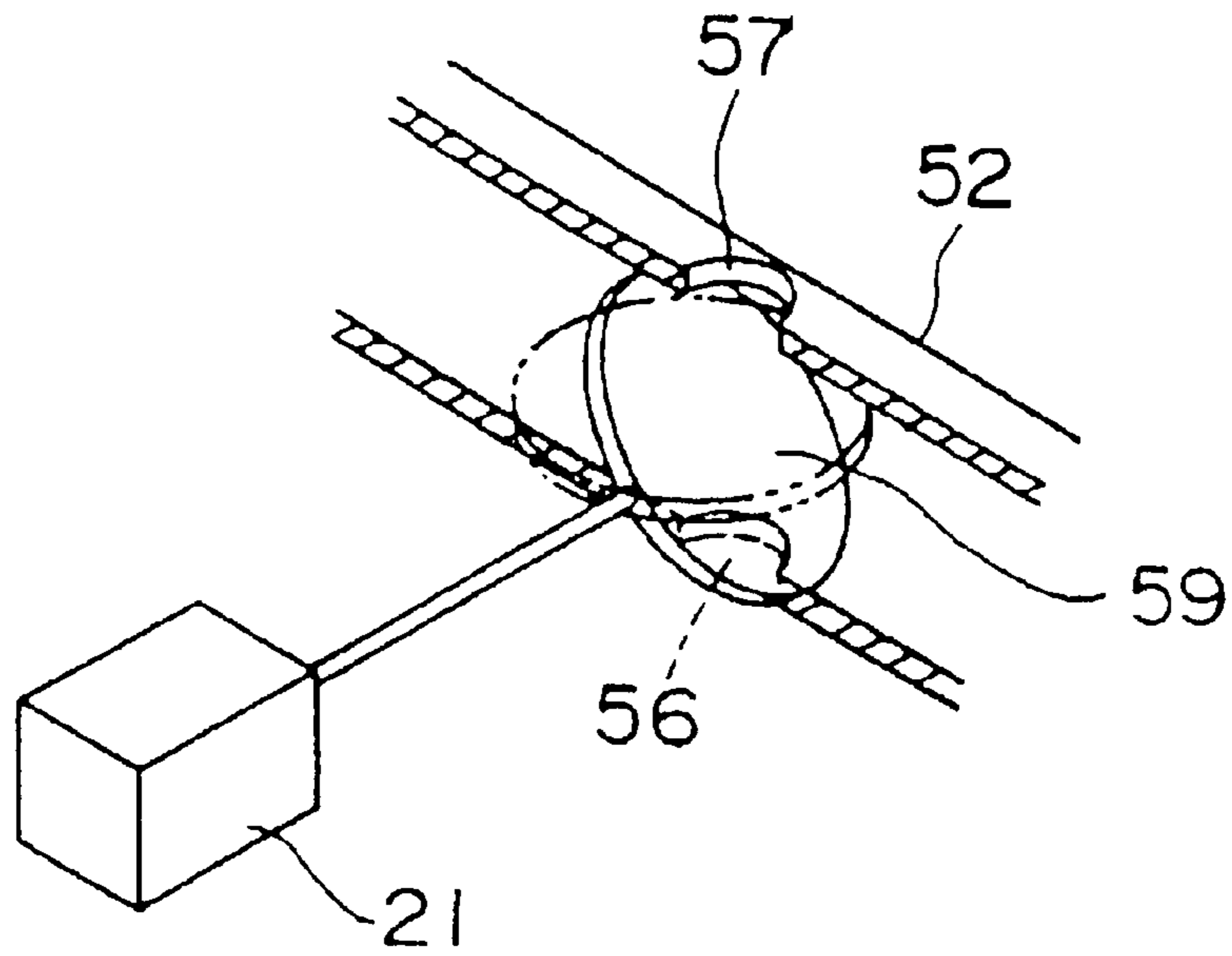

FIG.12

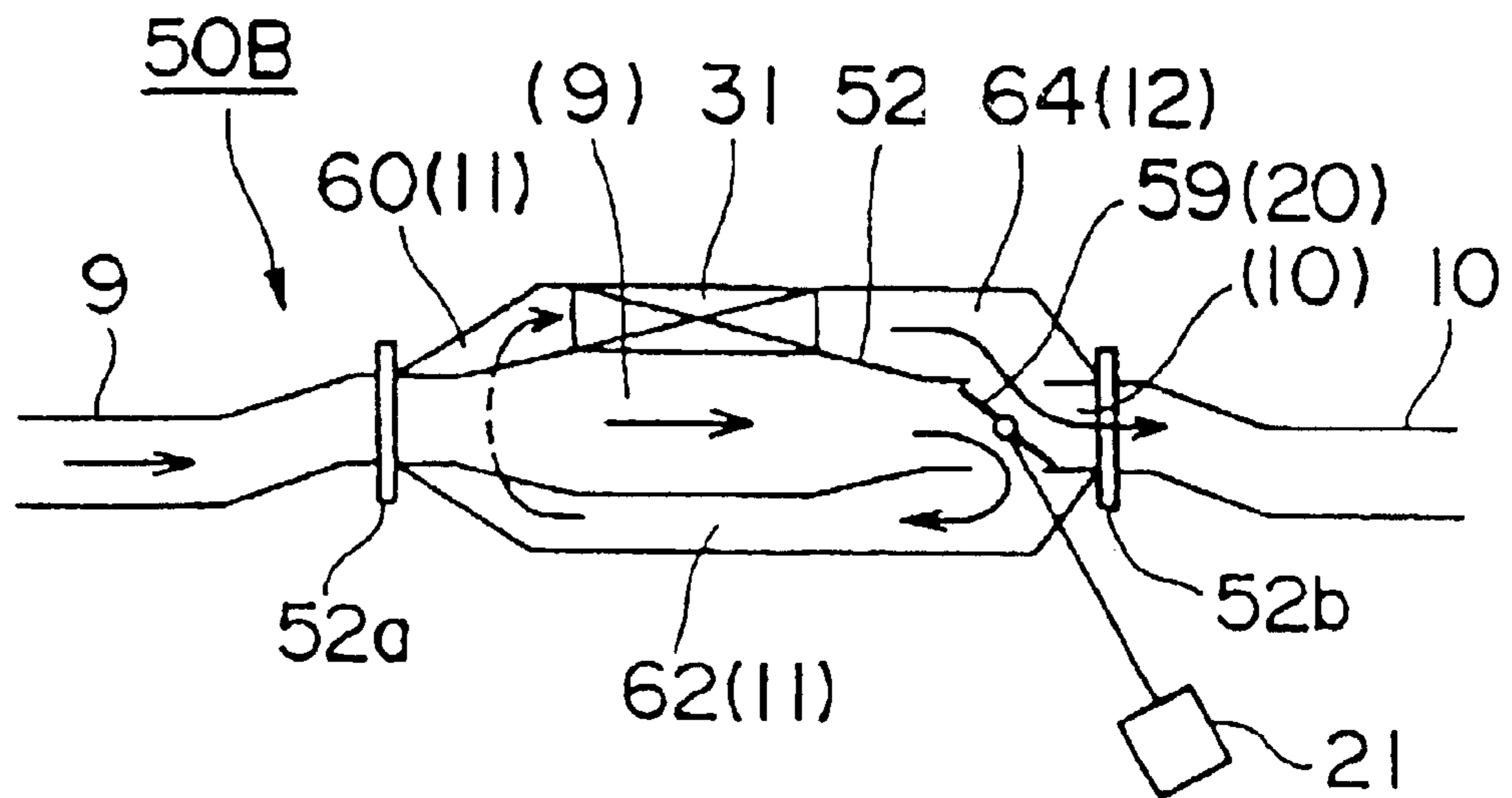

FIG. 13

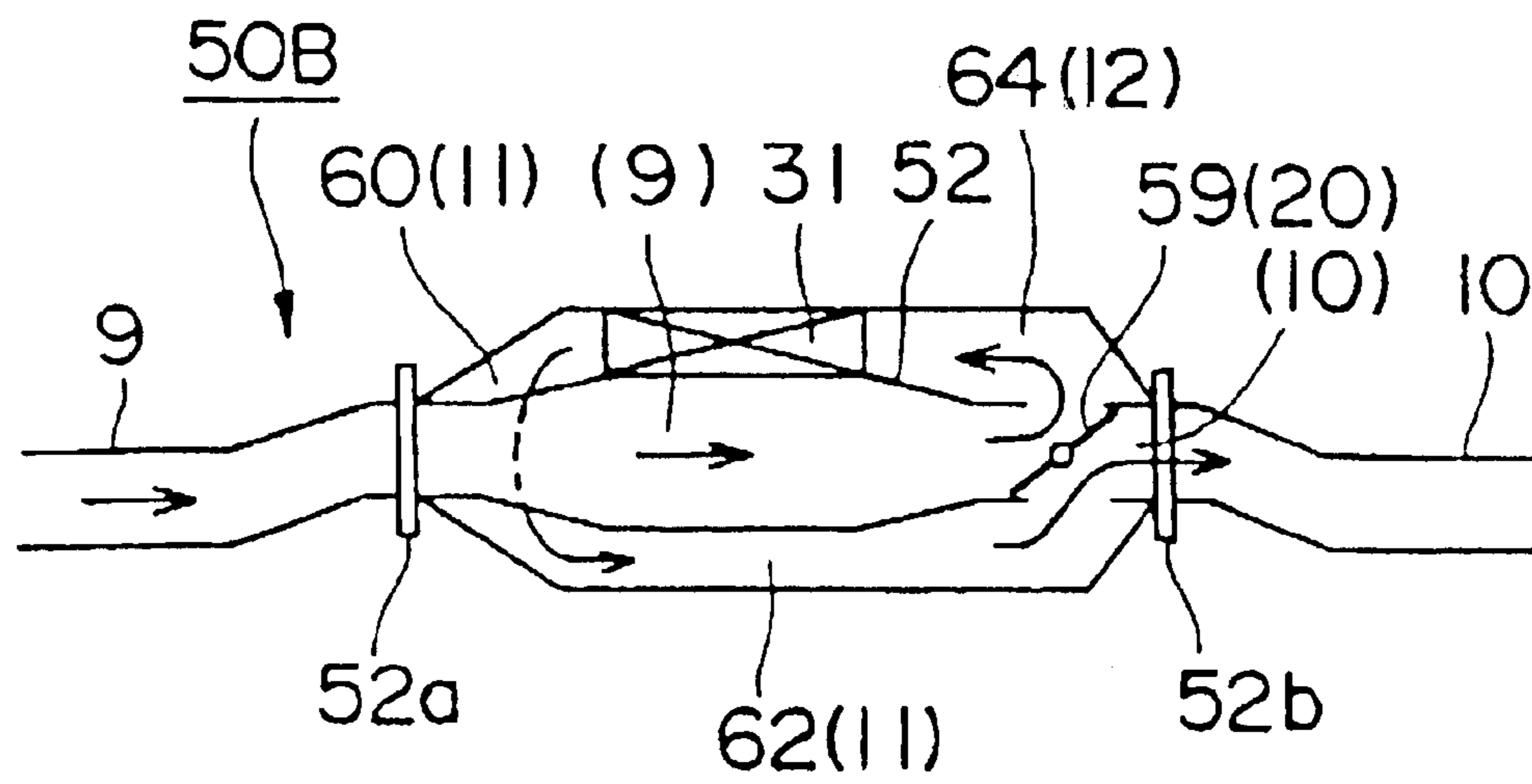

FIG. 14

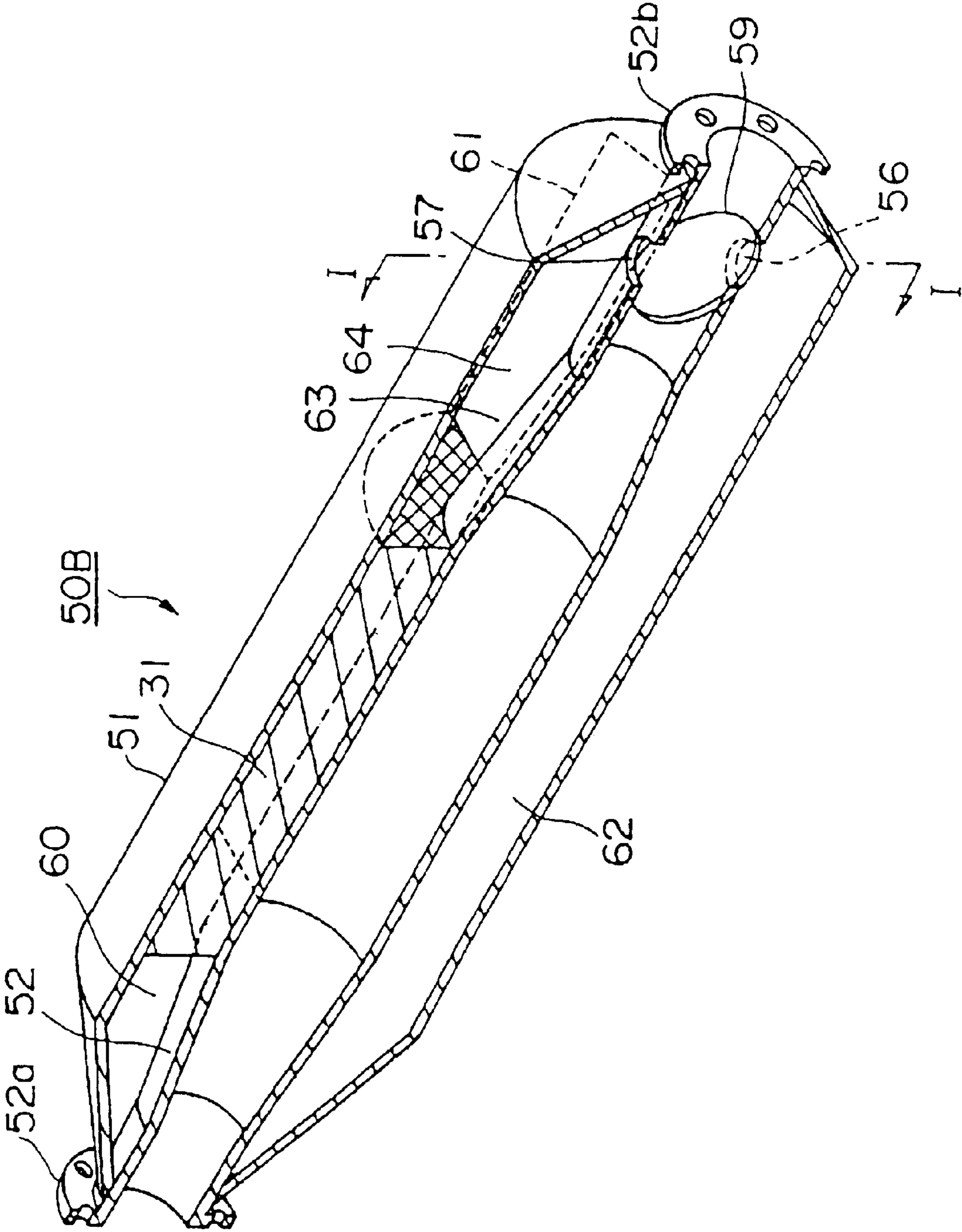

FIG. 15

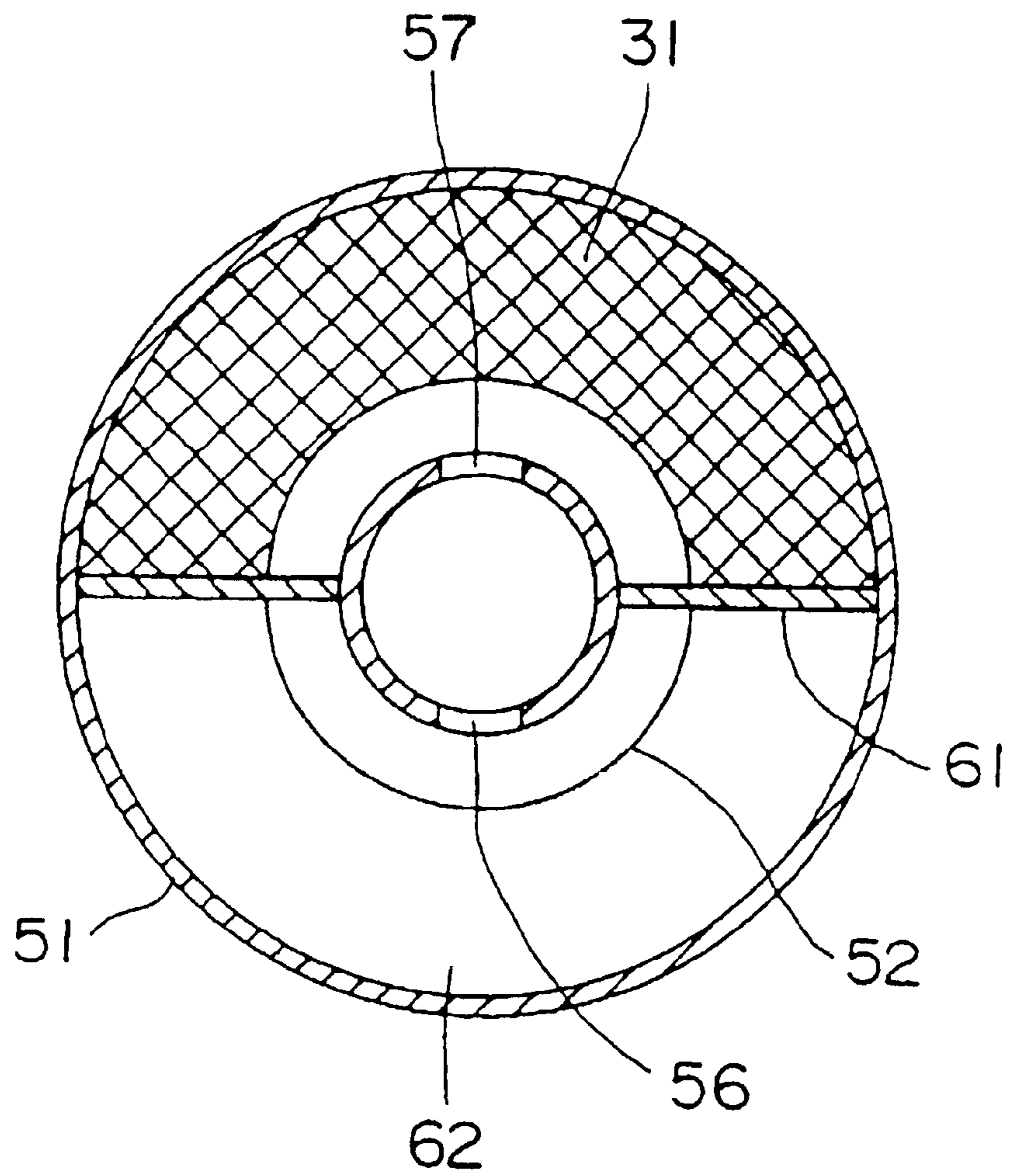

FIG. 16

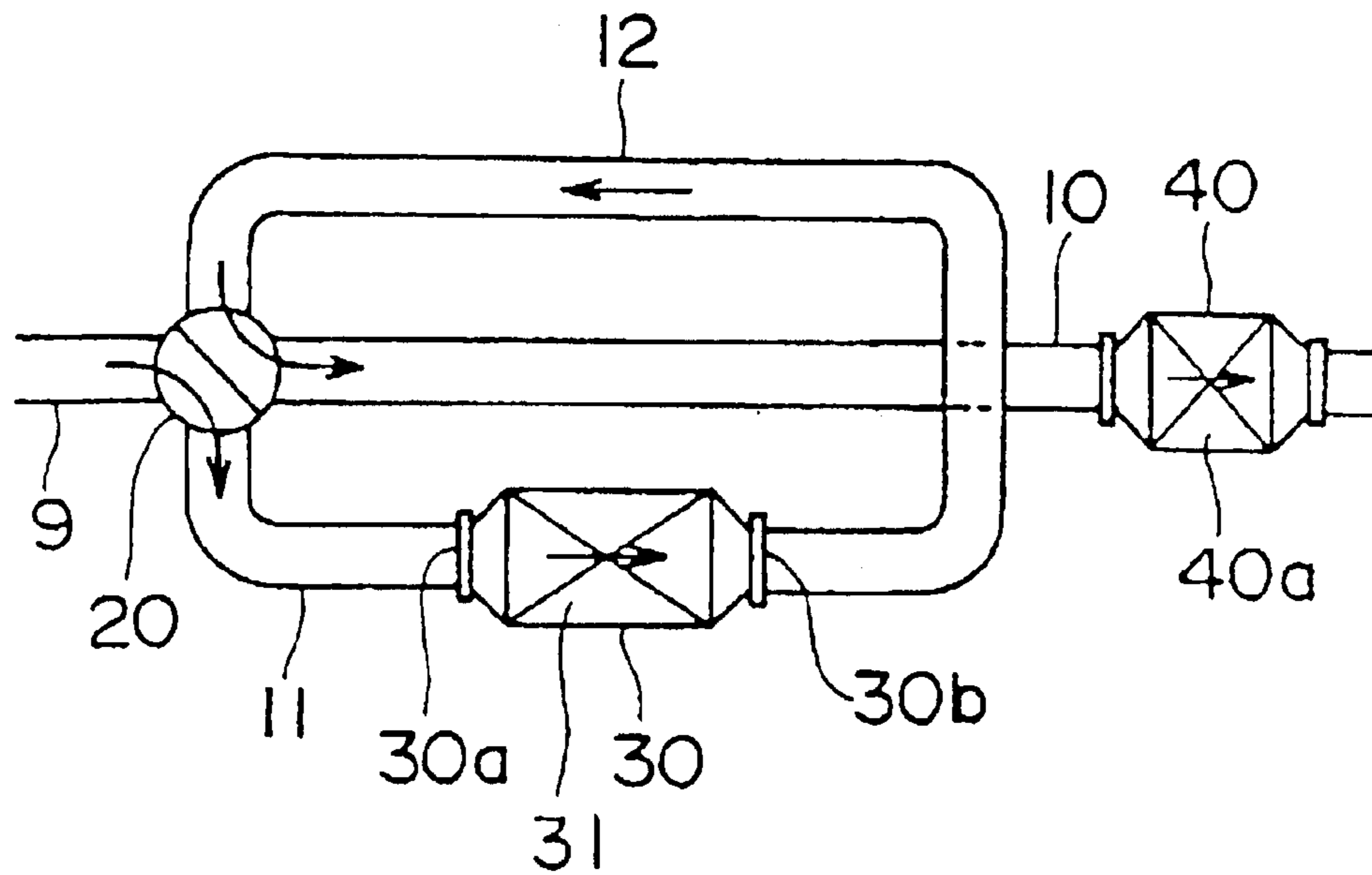

FIG. 17

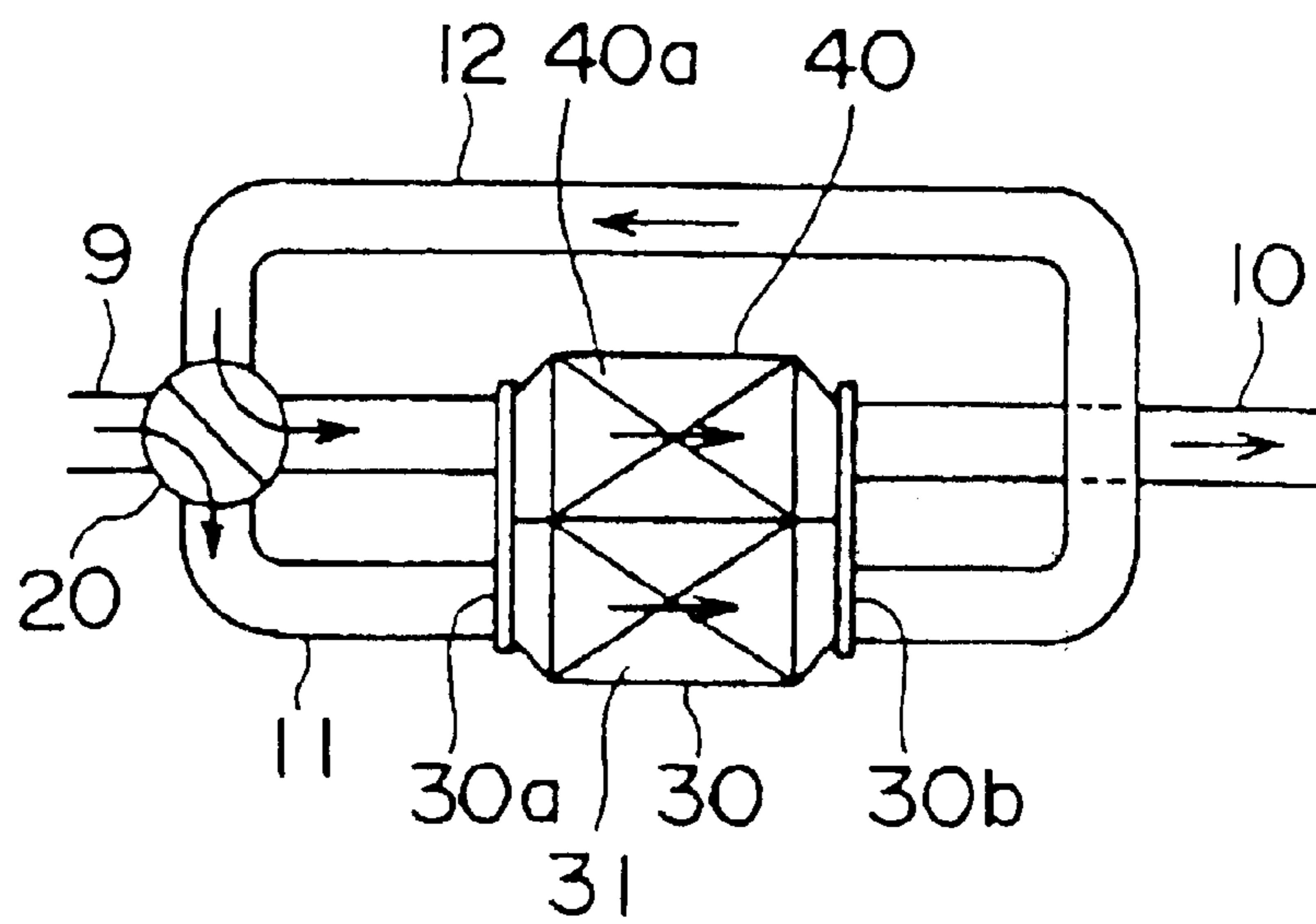

FIG. 18

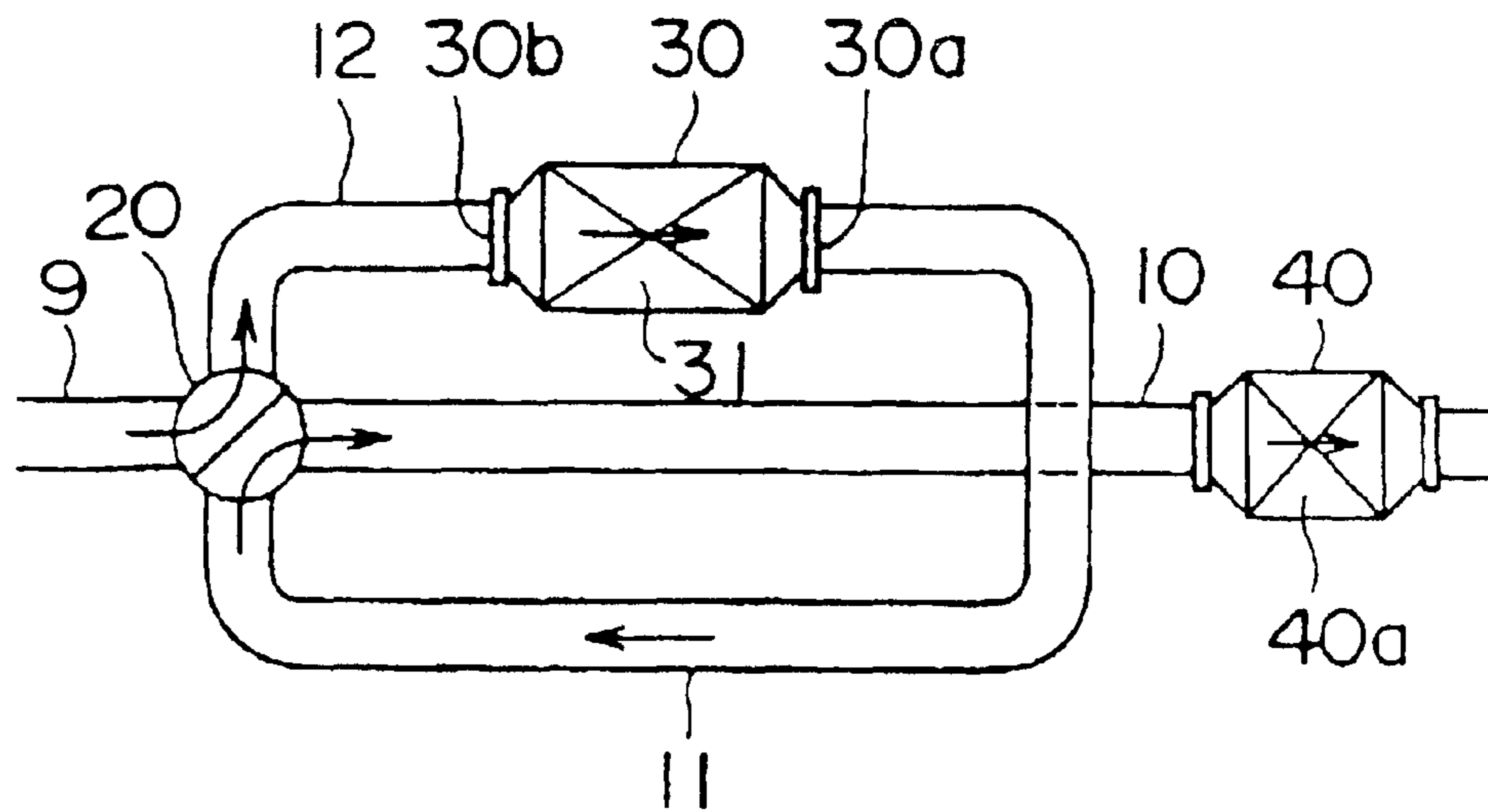

FIG. 19

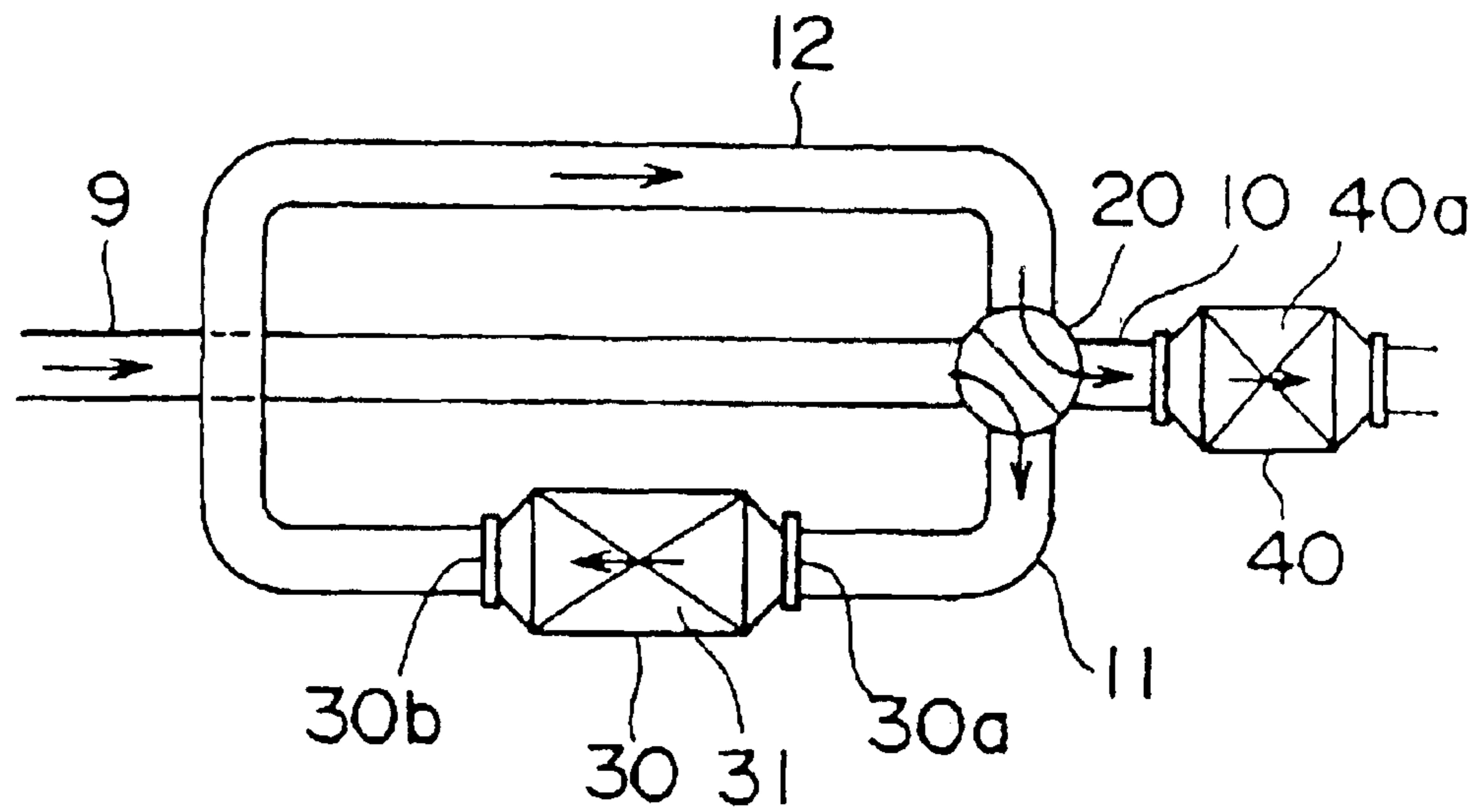

FIG. 20

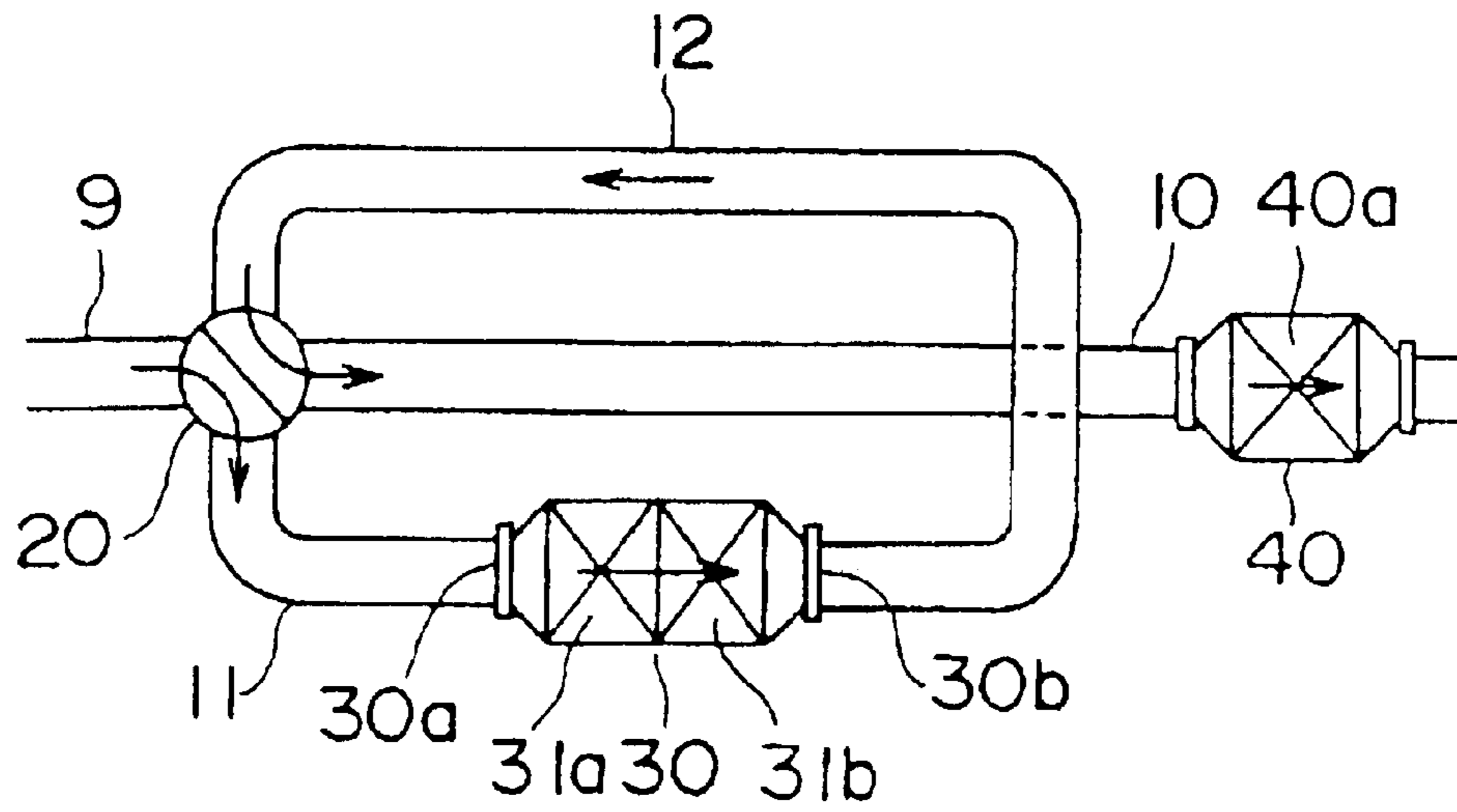

FIG. 21

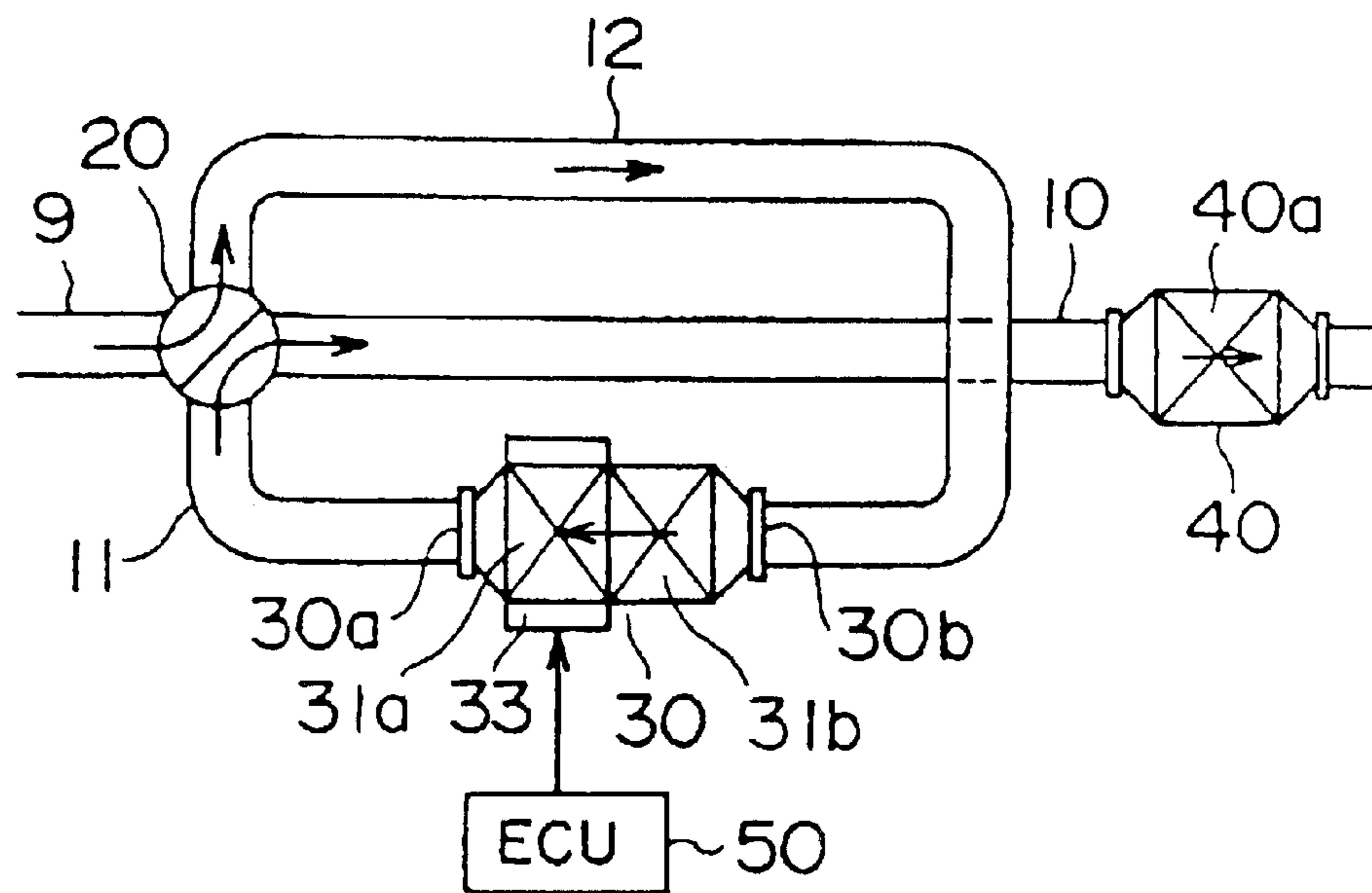

FIG.22

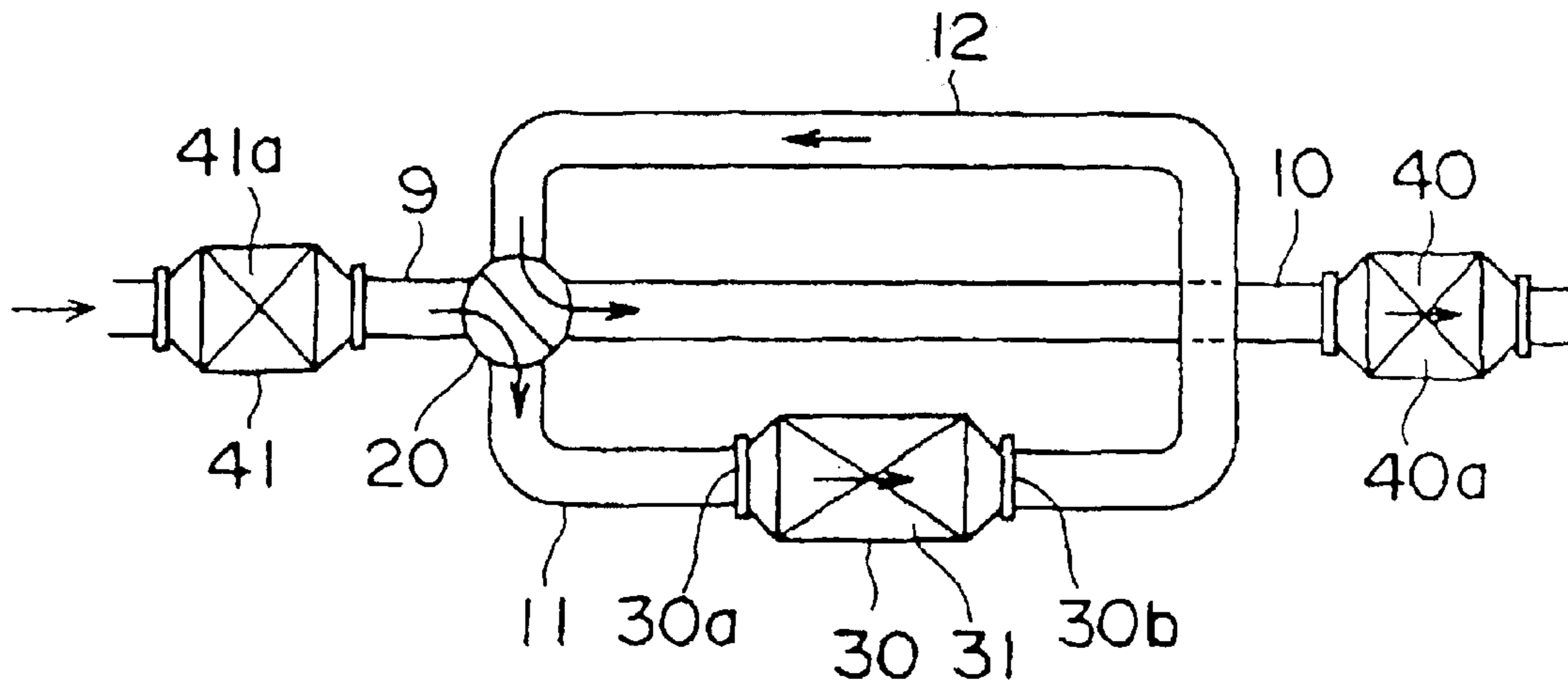

FIG.23

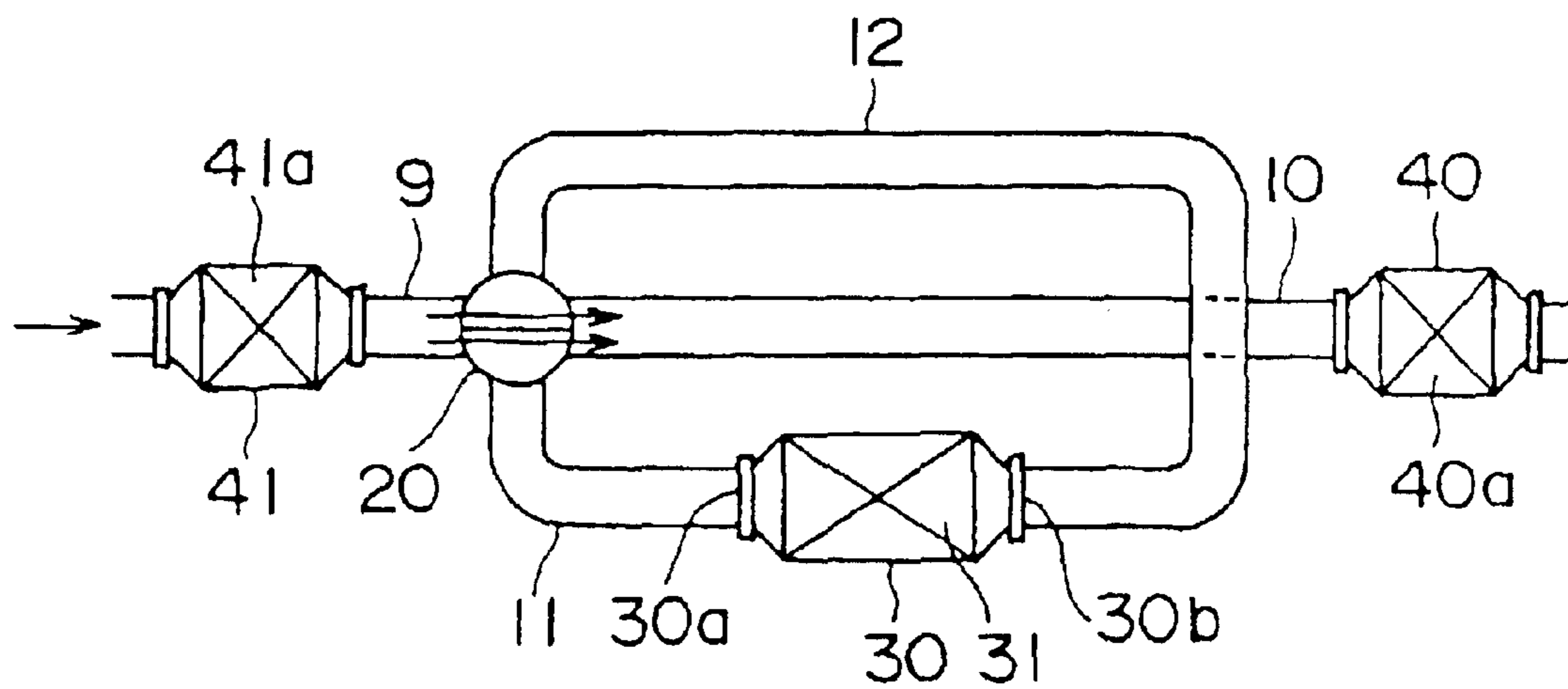

FIG. 24

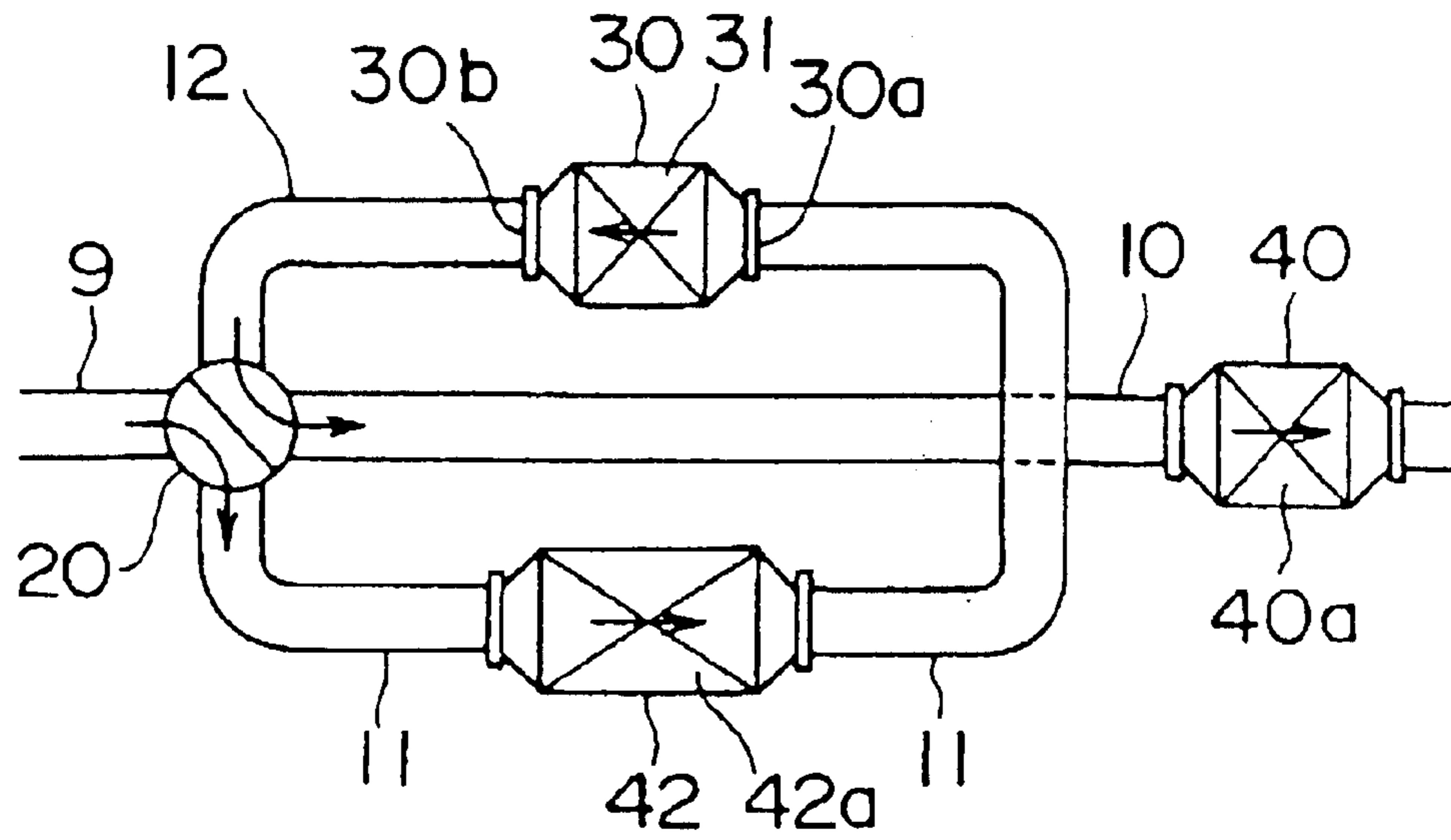

FIG. 25

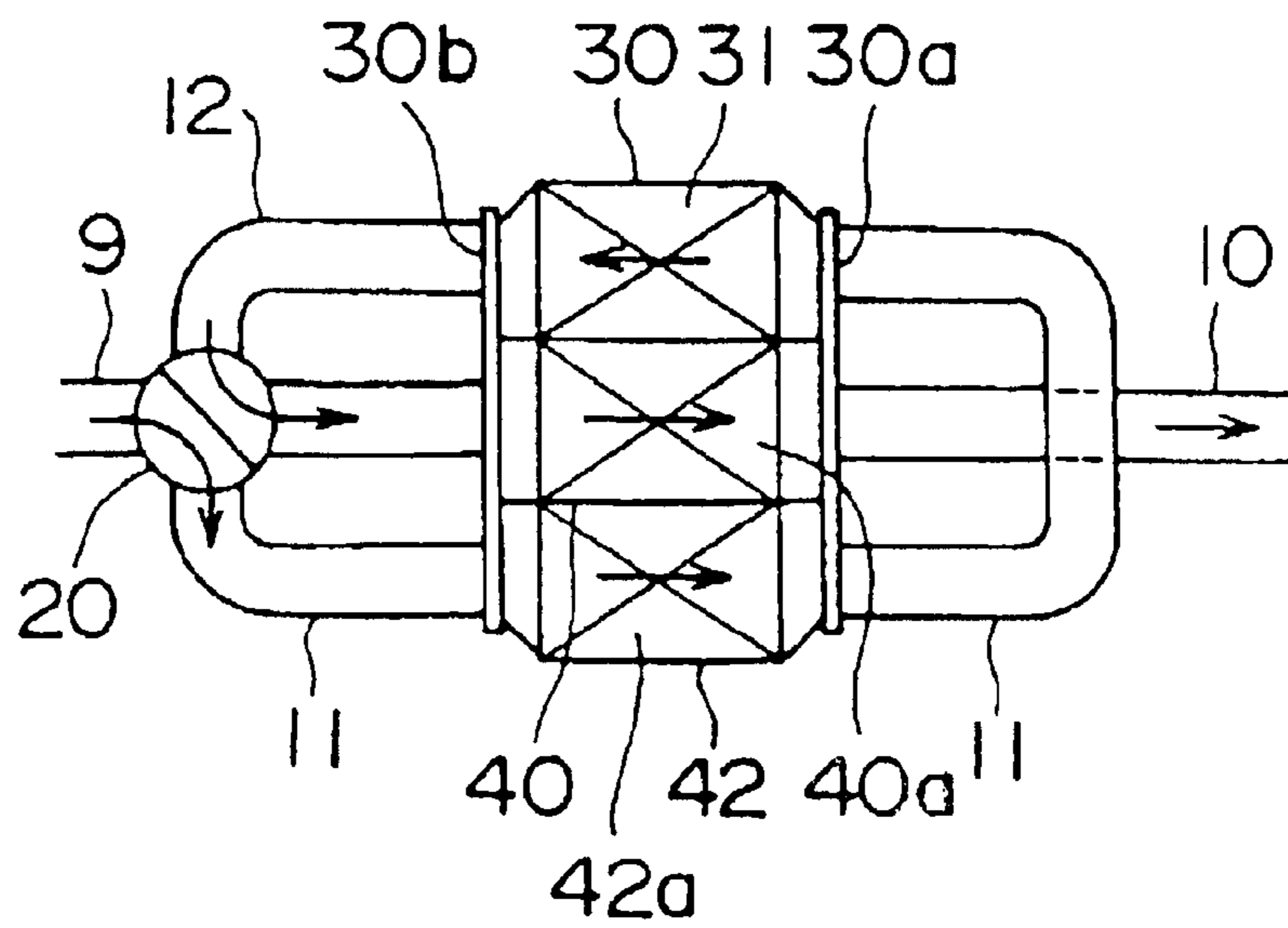

FIG. 26

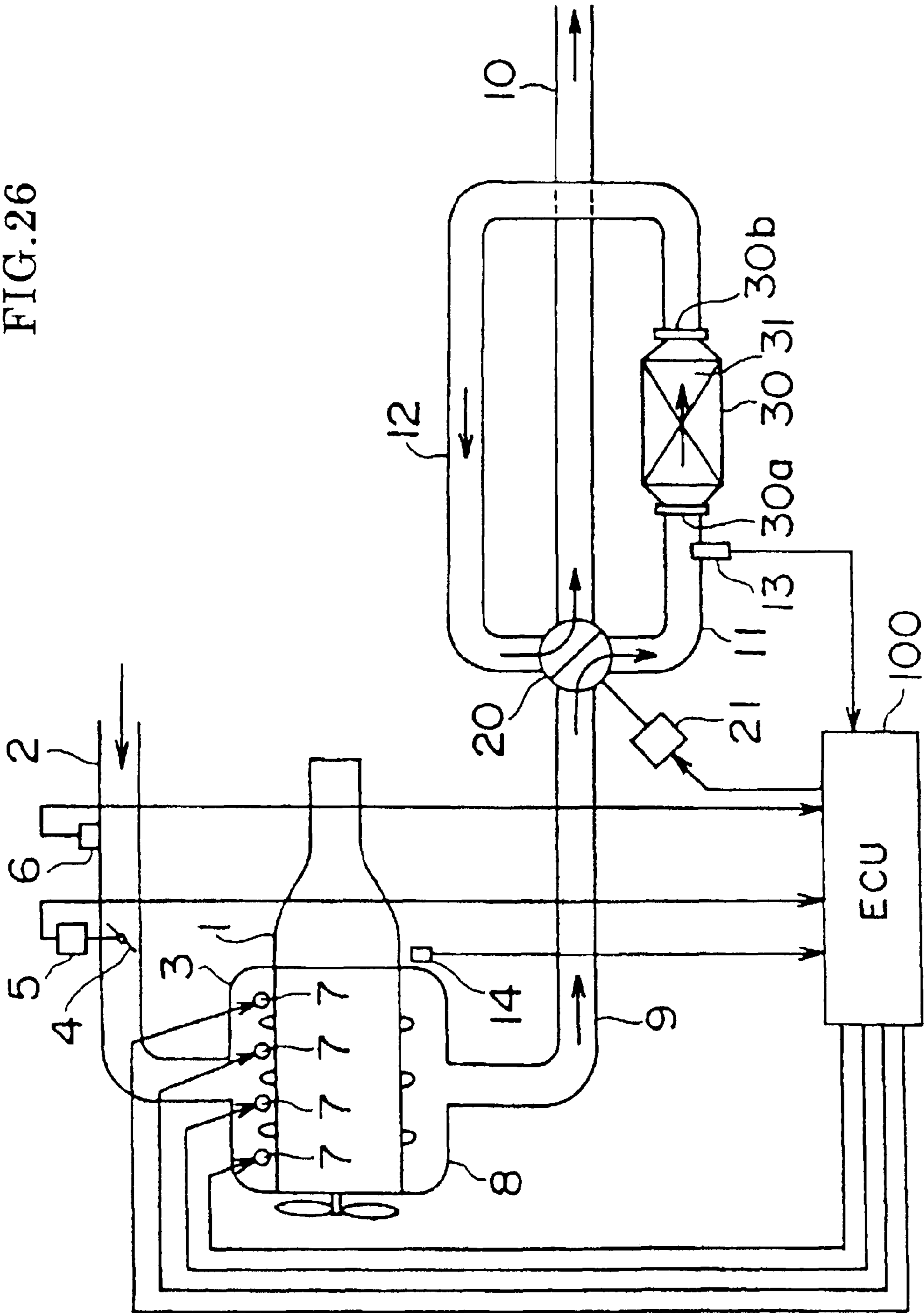

FIG.27

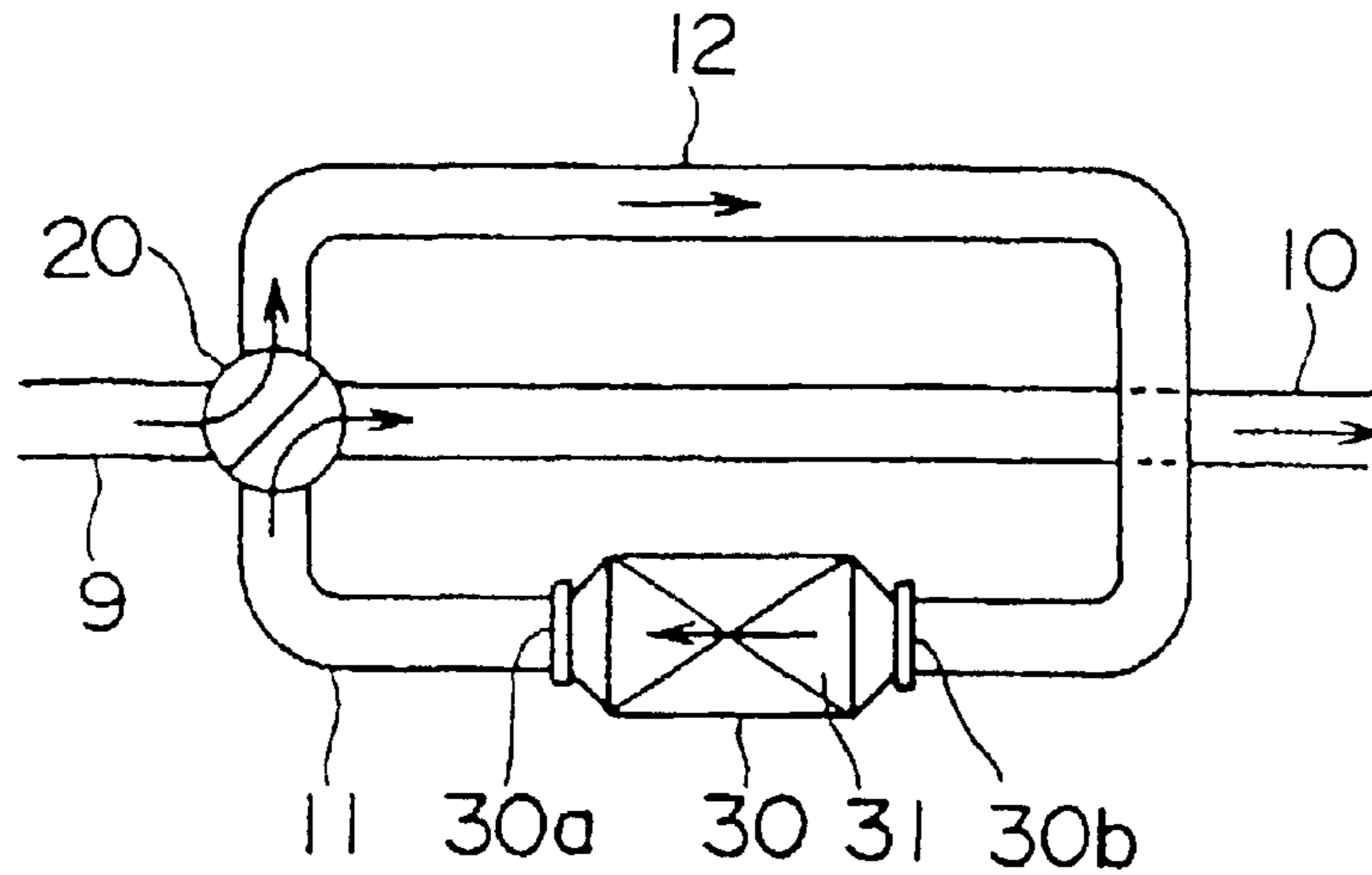

FIG.28

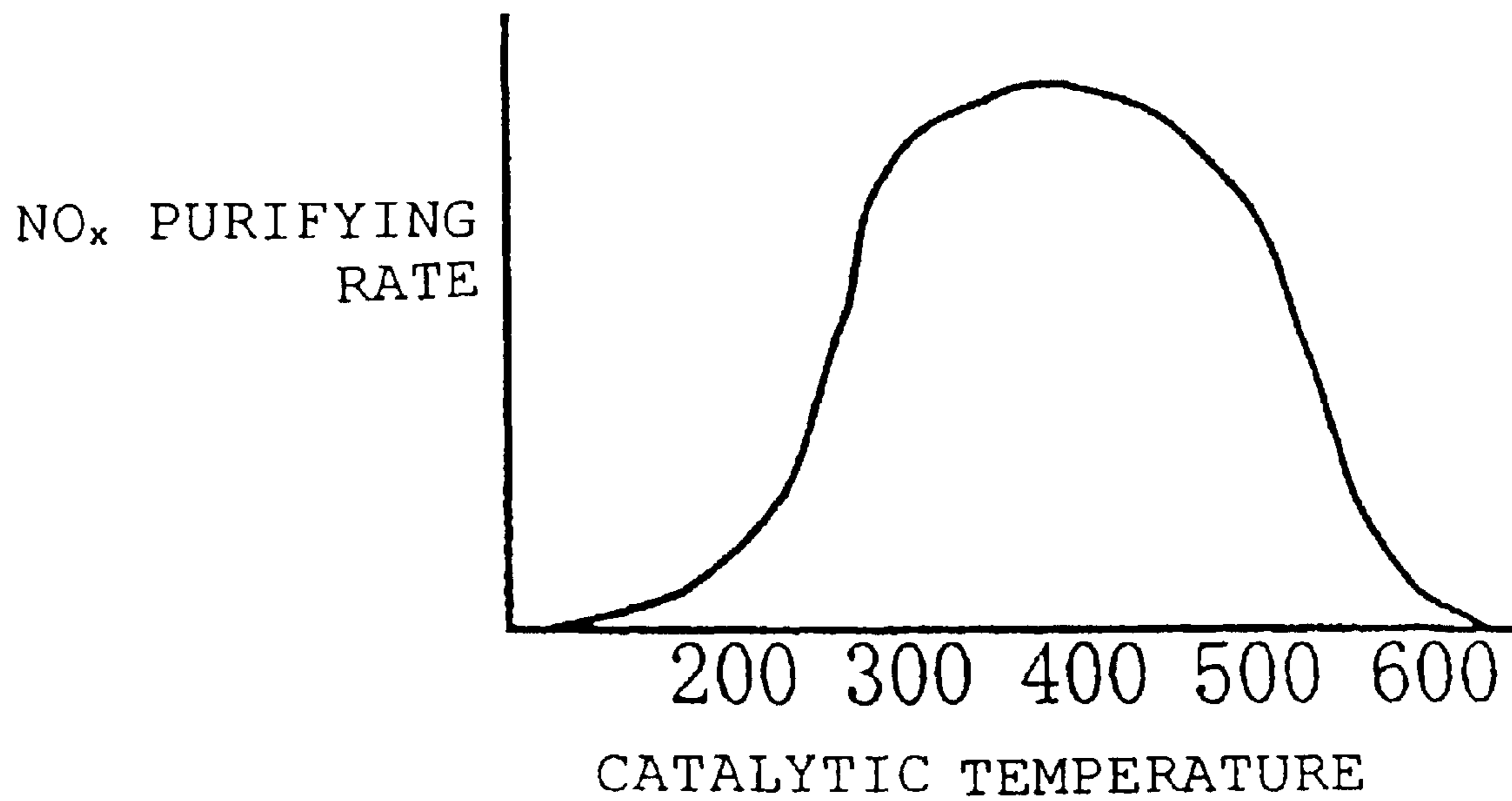

FIG. 29

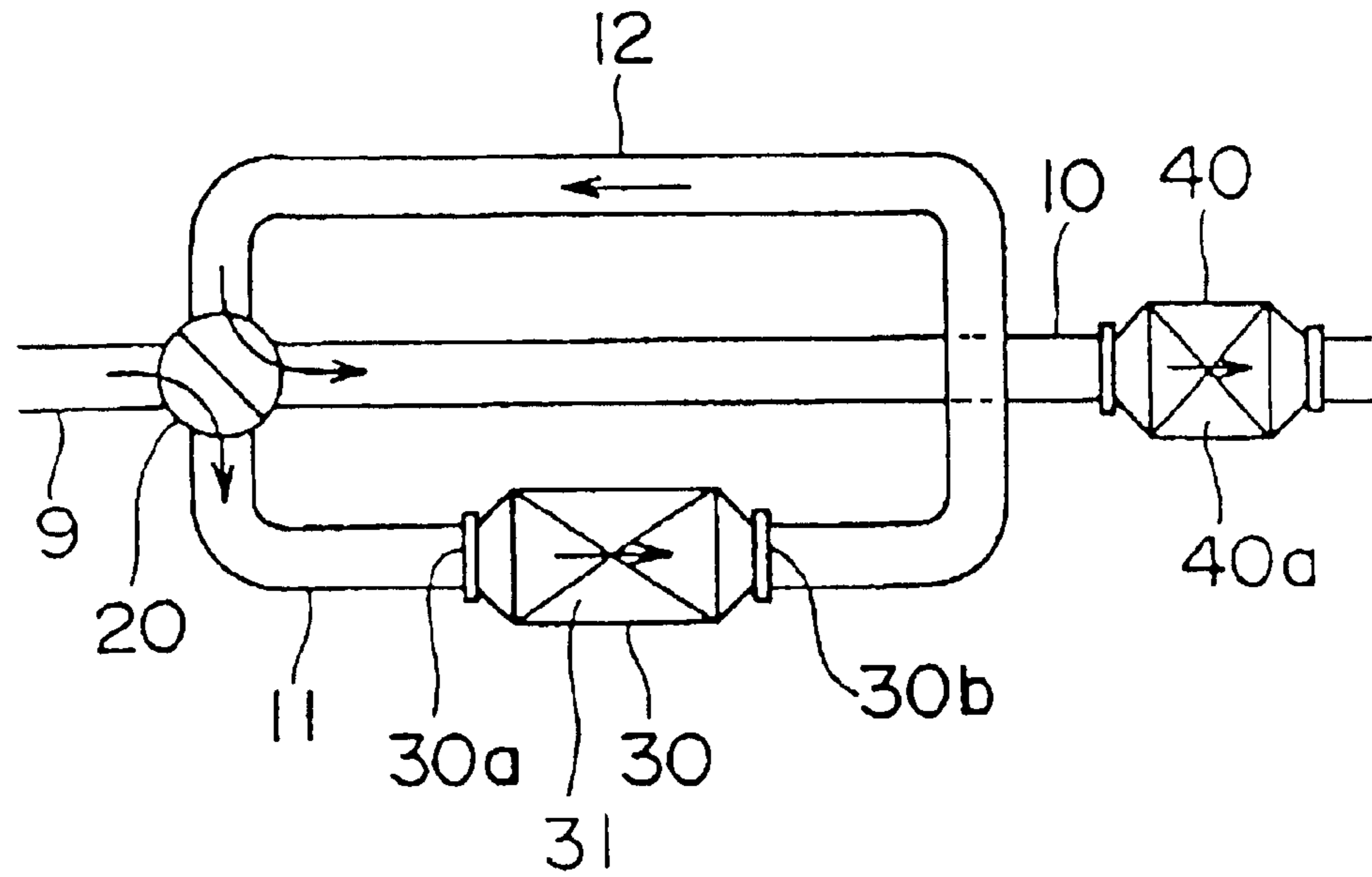

FIG. 30

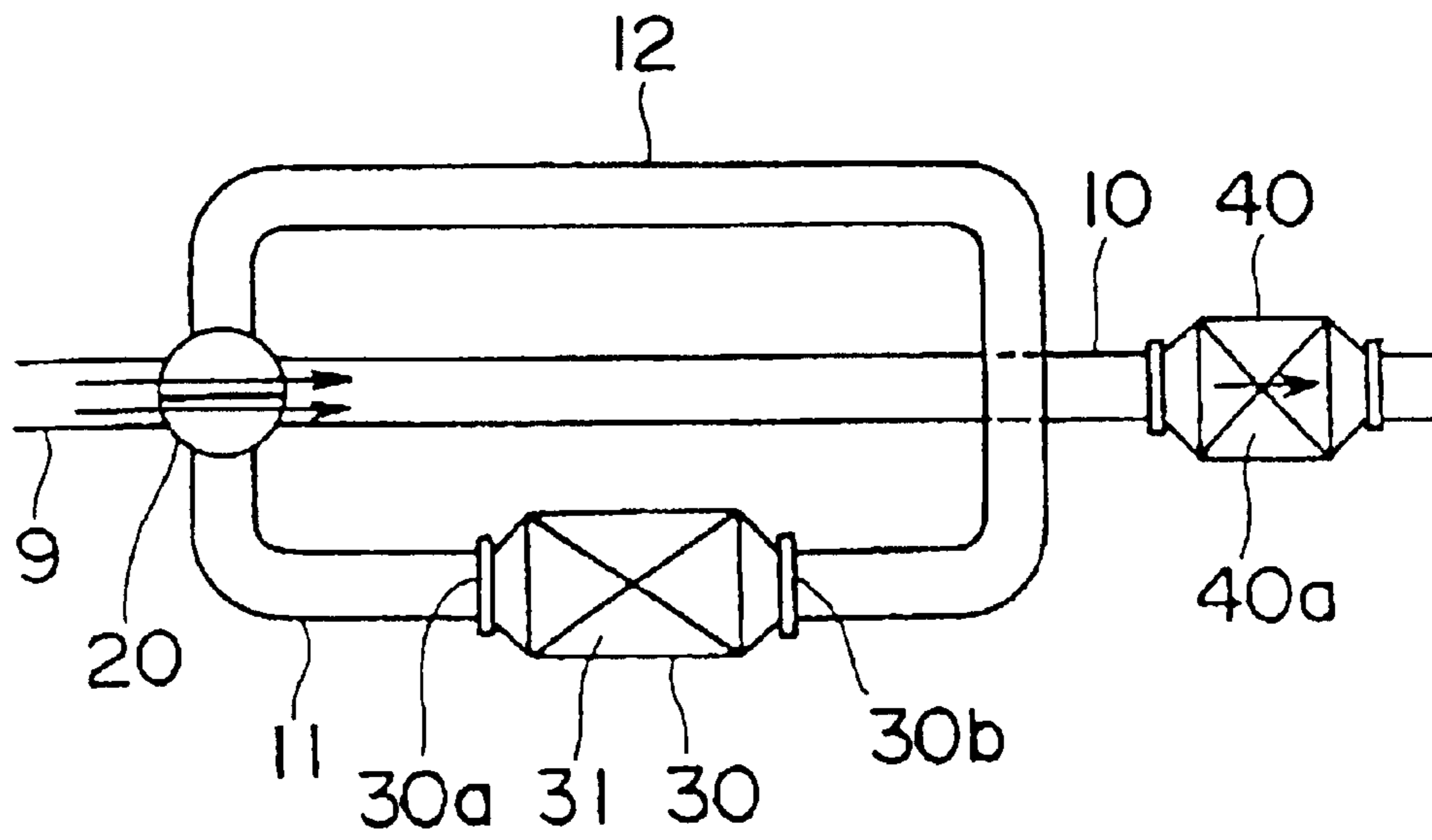

FIG. 31

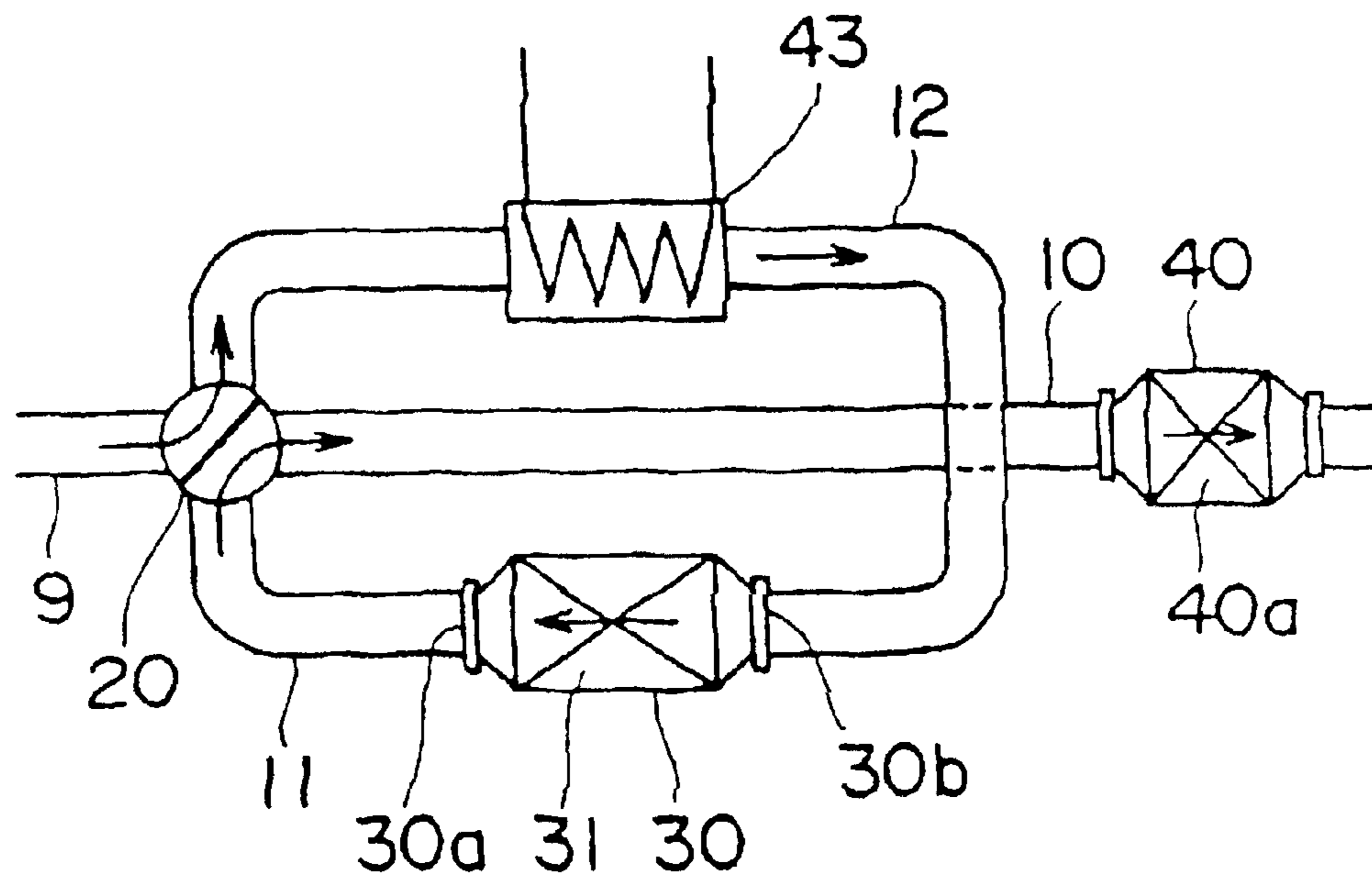

FIG. 32

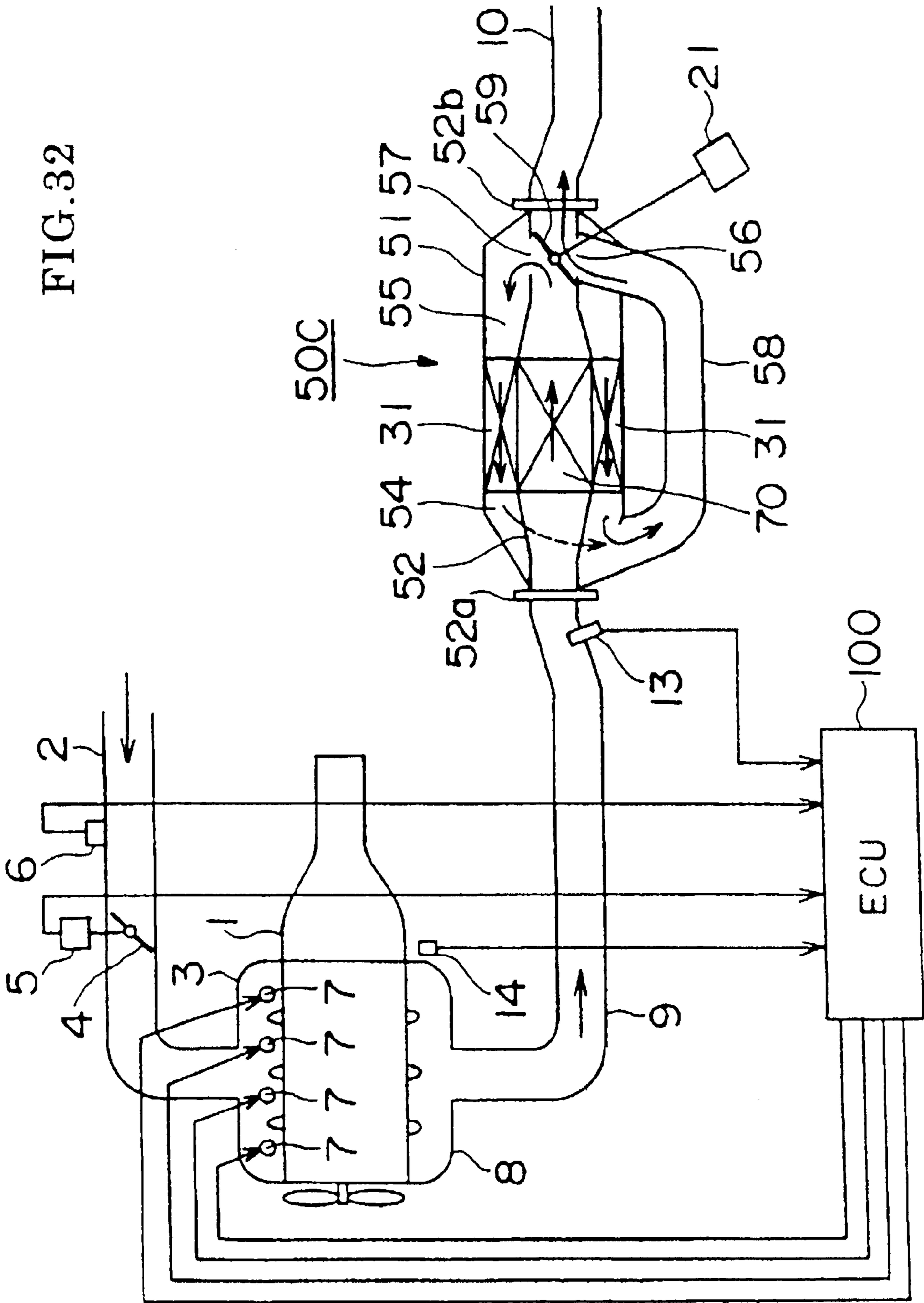

FIG.33

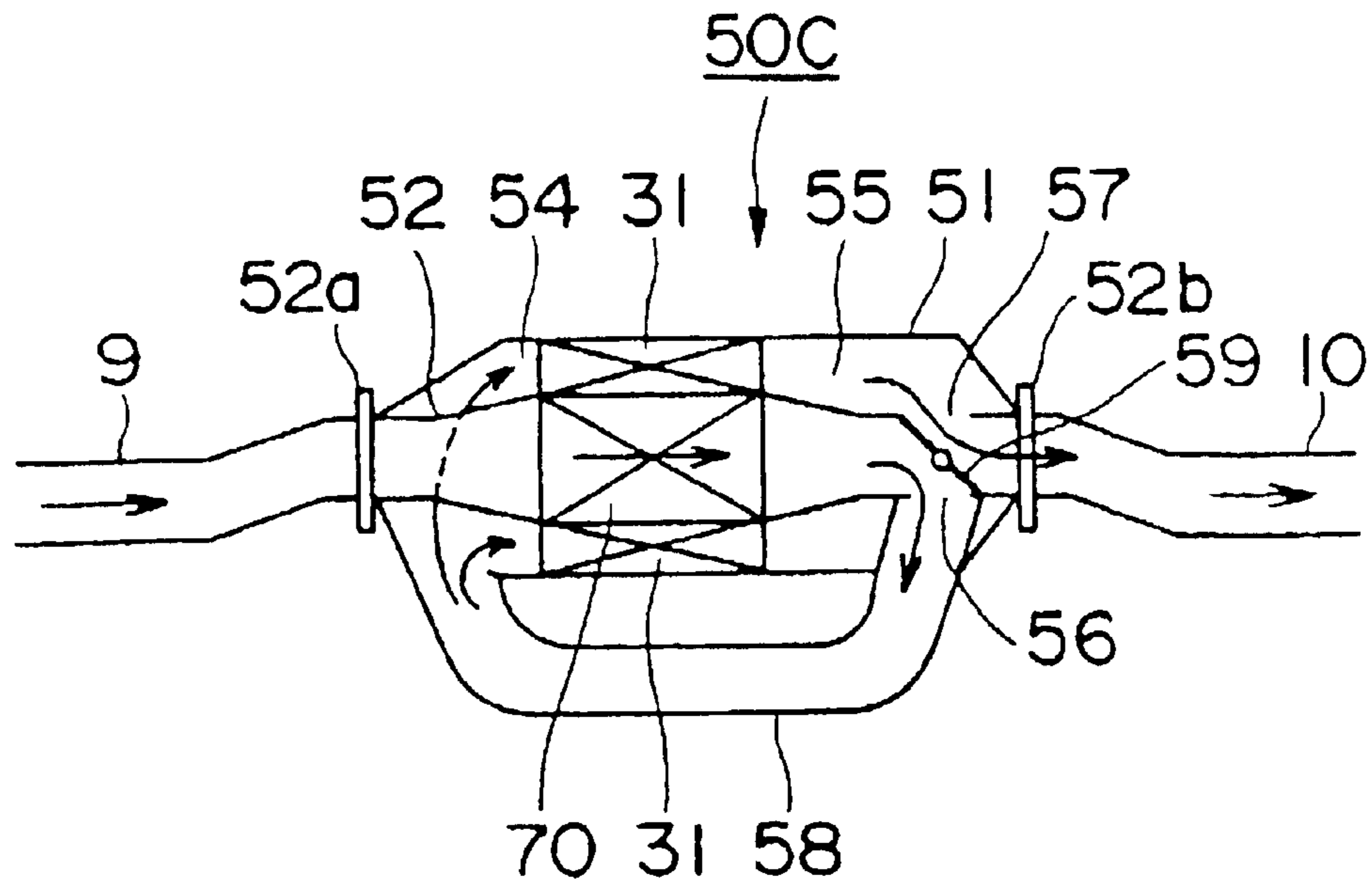
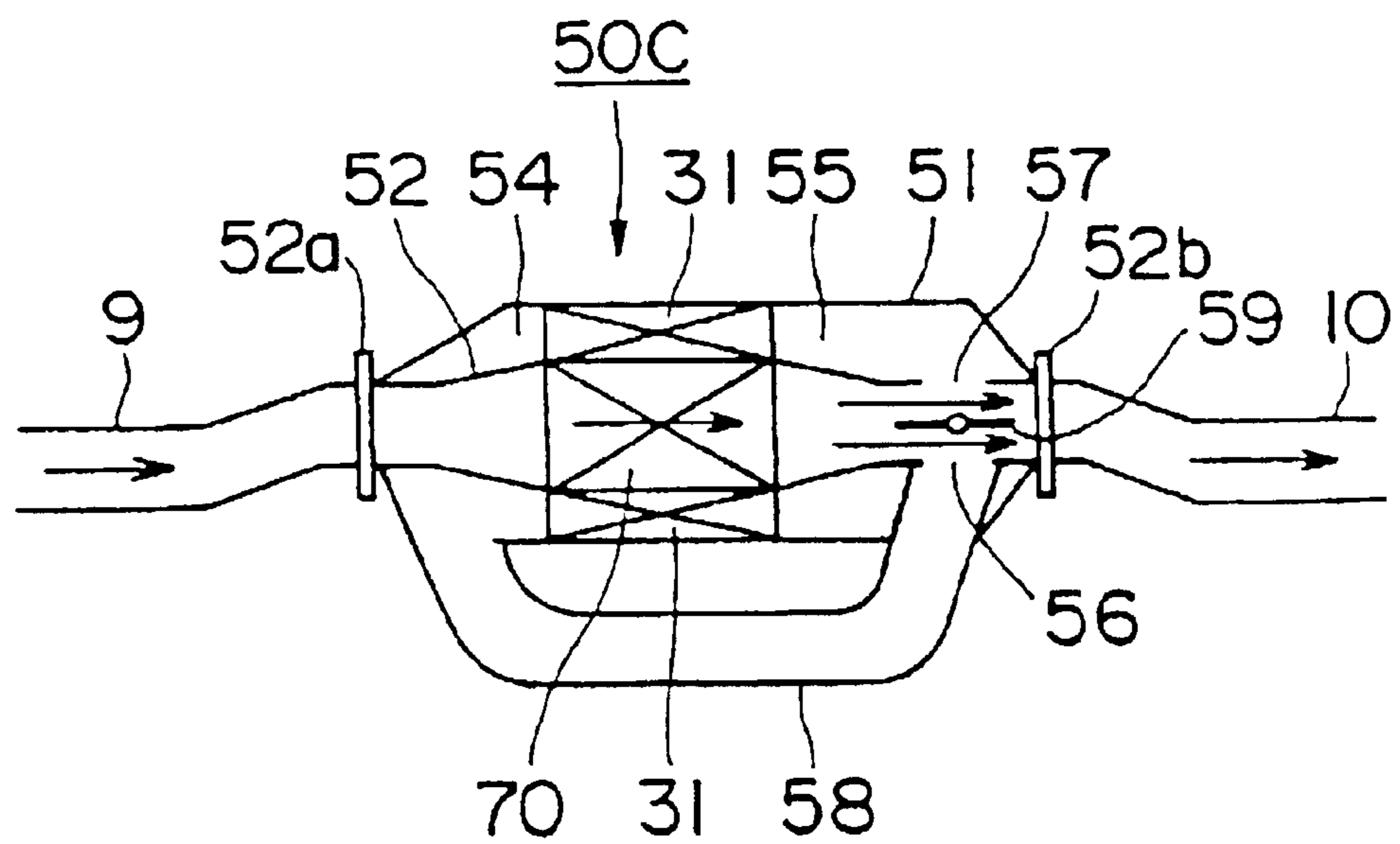

FIG.34



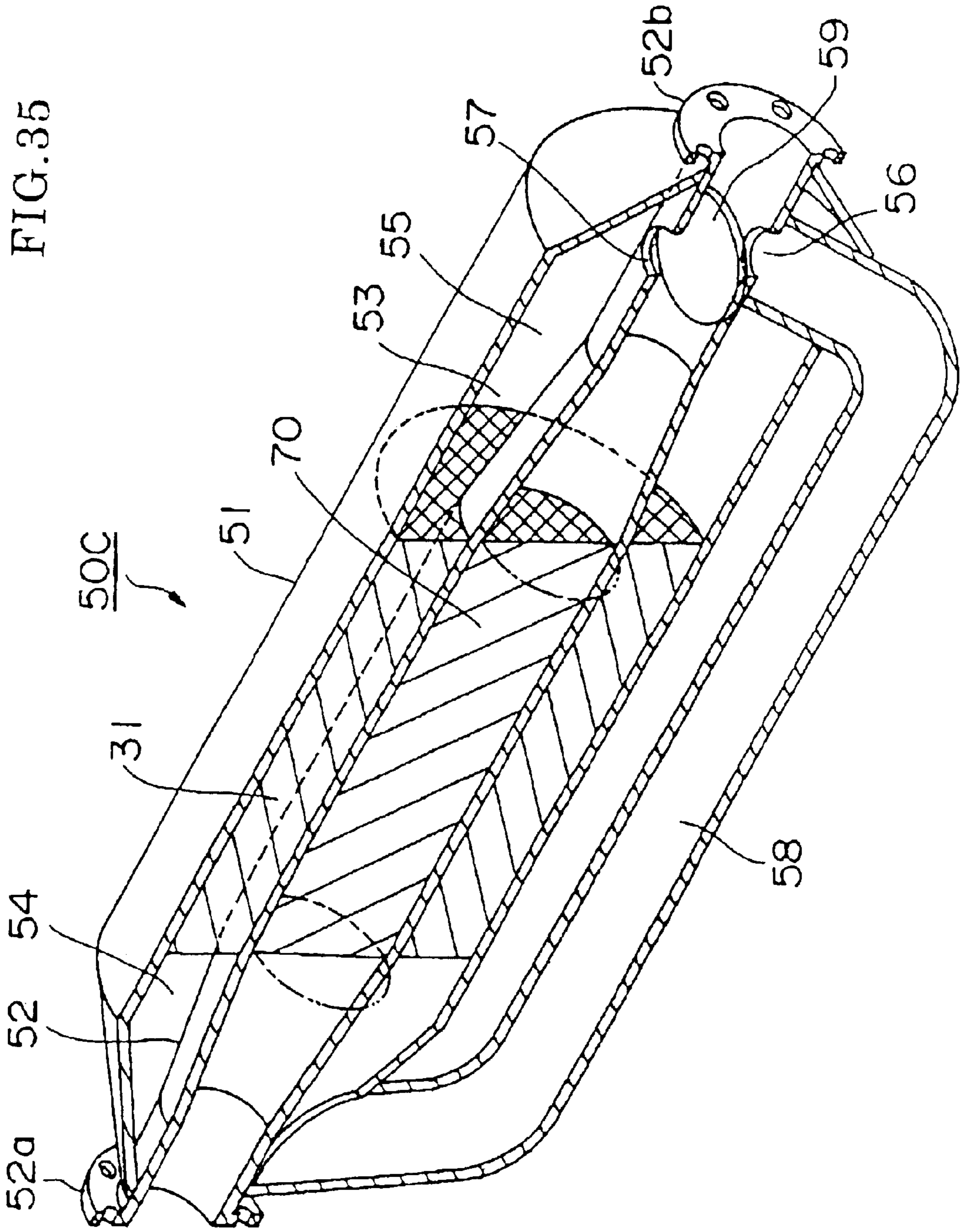

FIG. 36

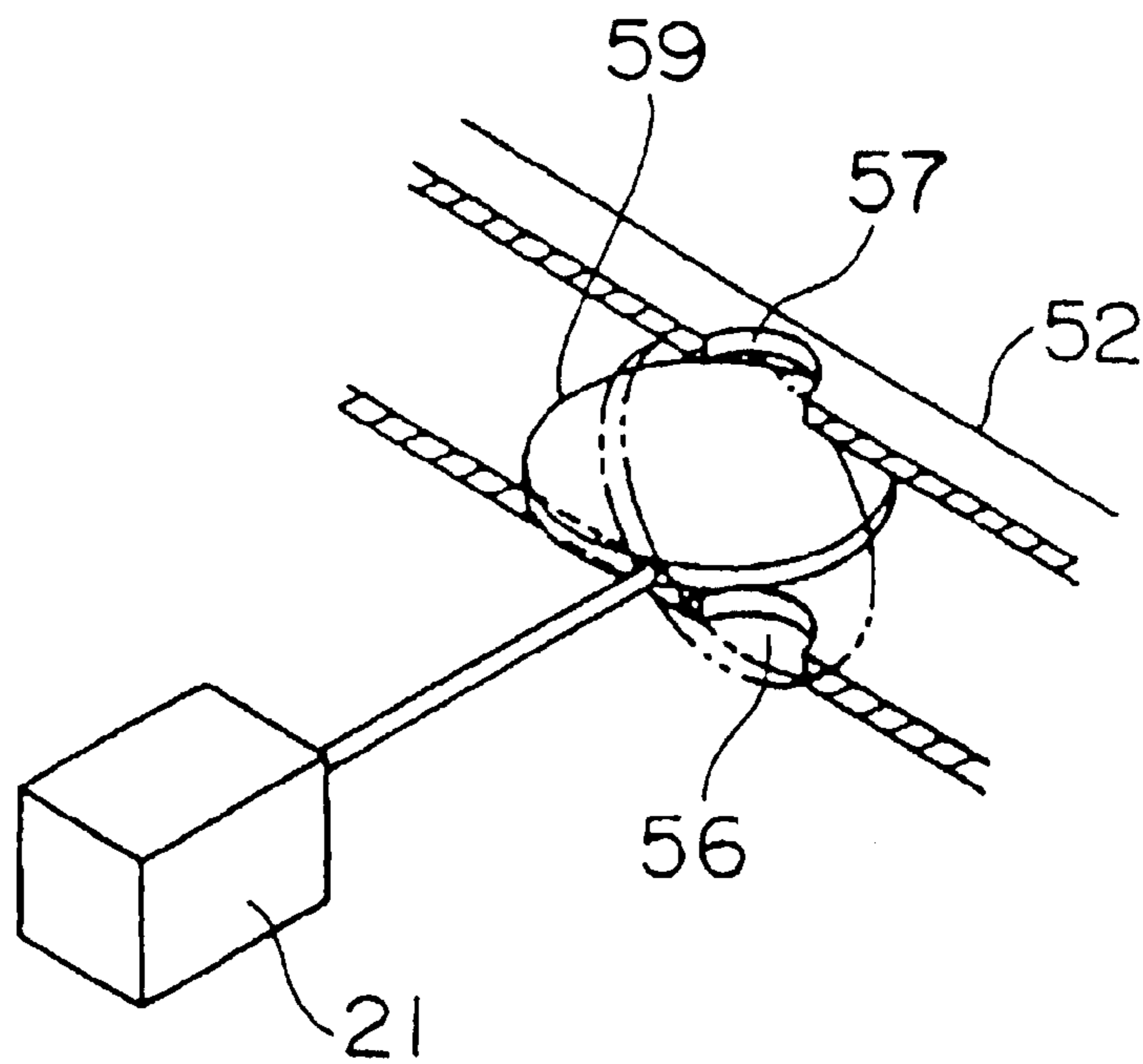

FIG. 37

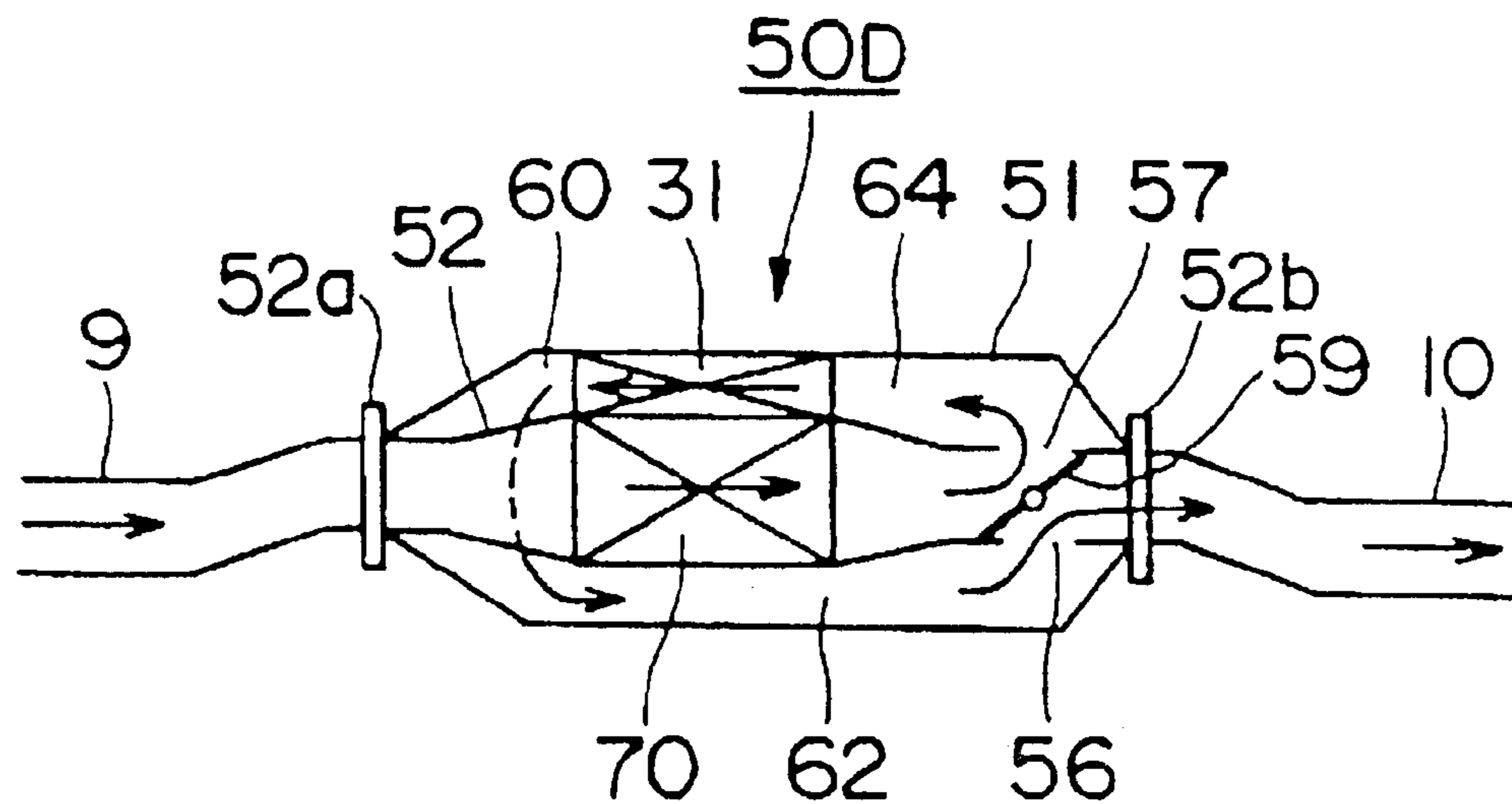

FIG.38

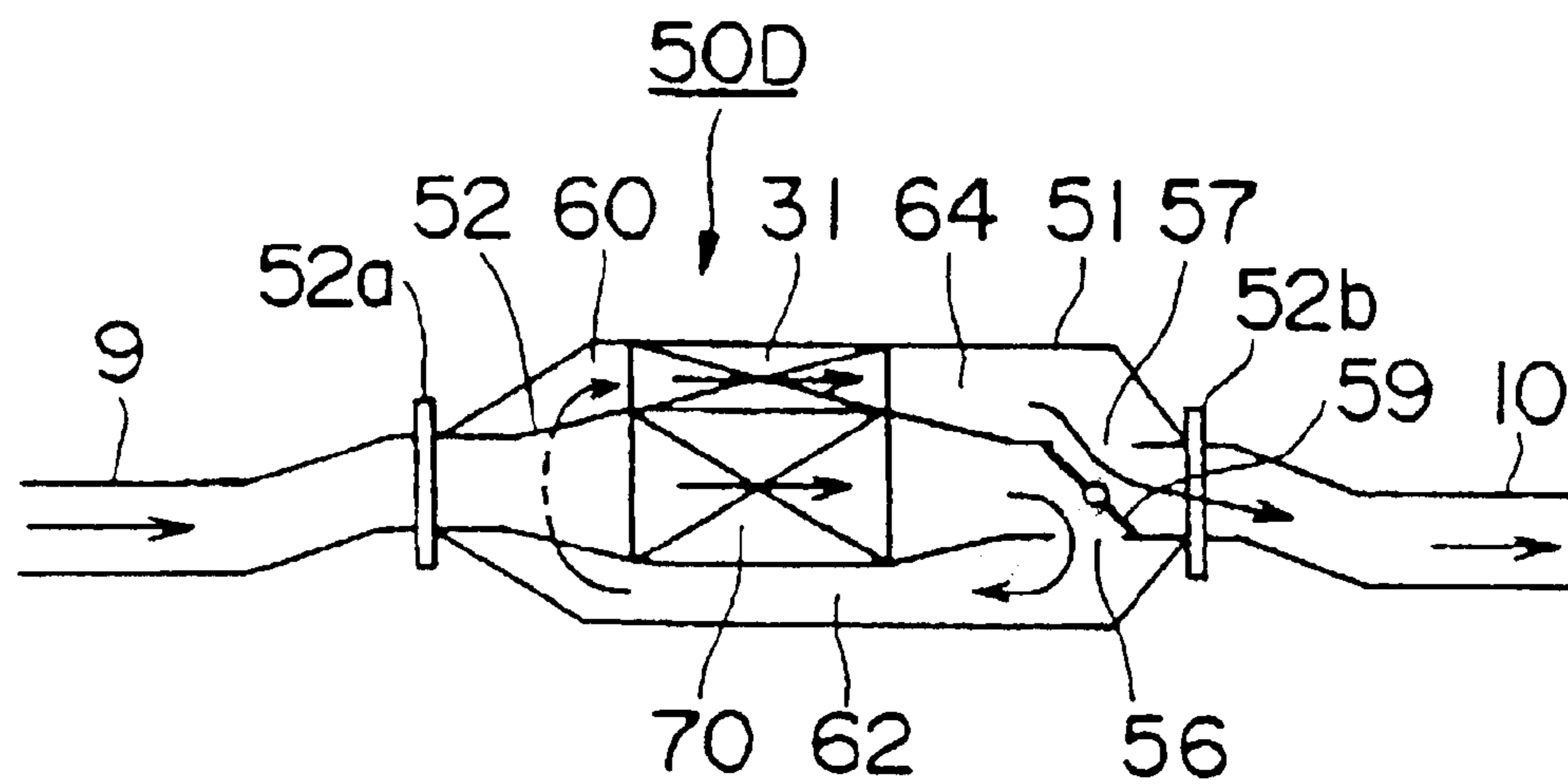
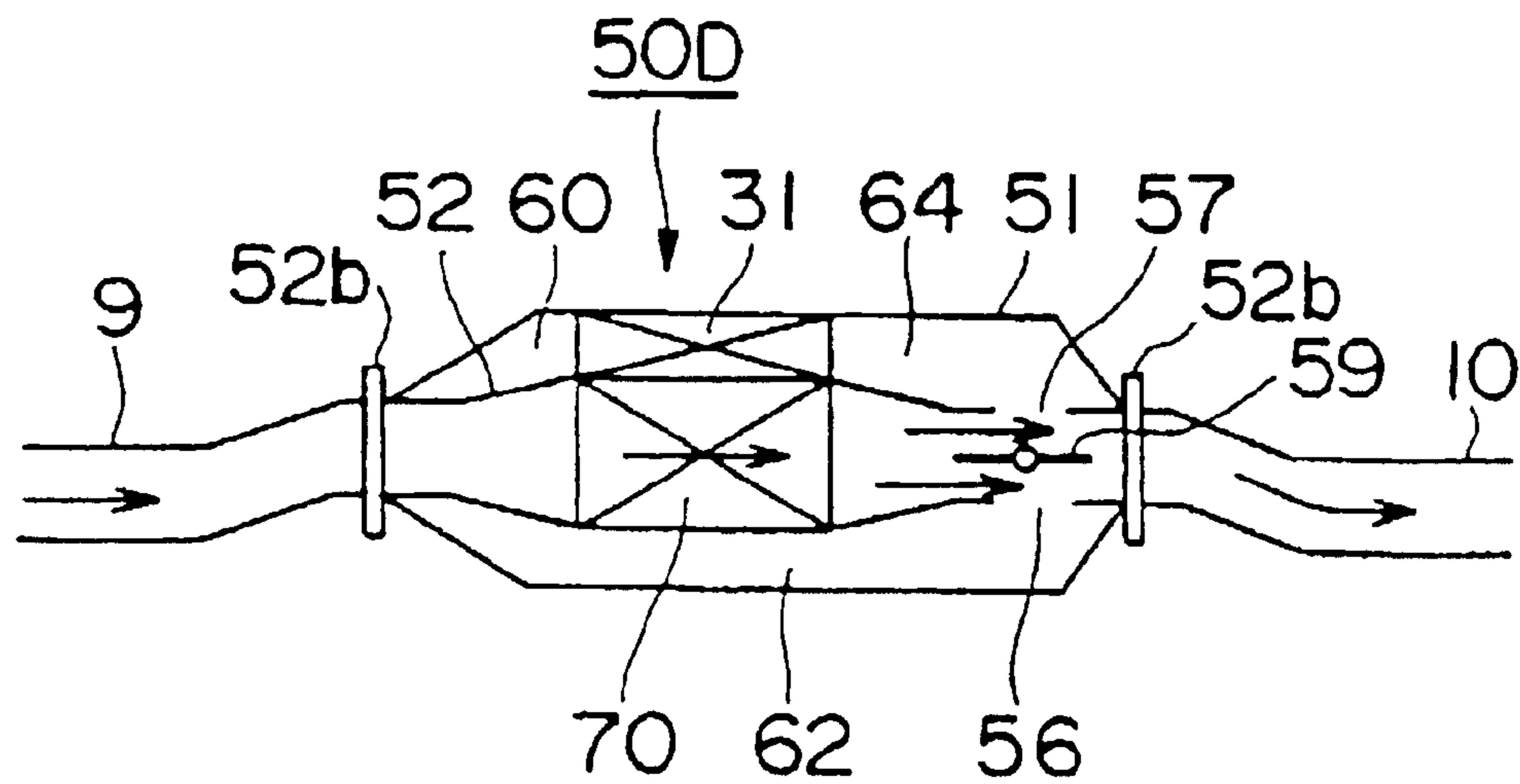

FIG.39



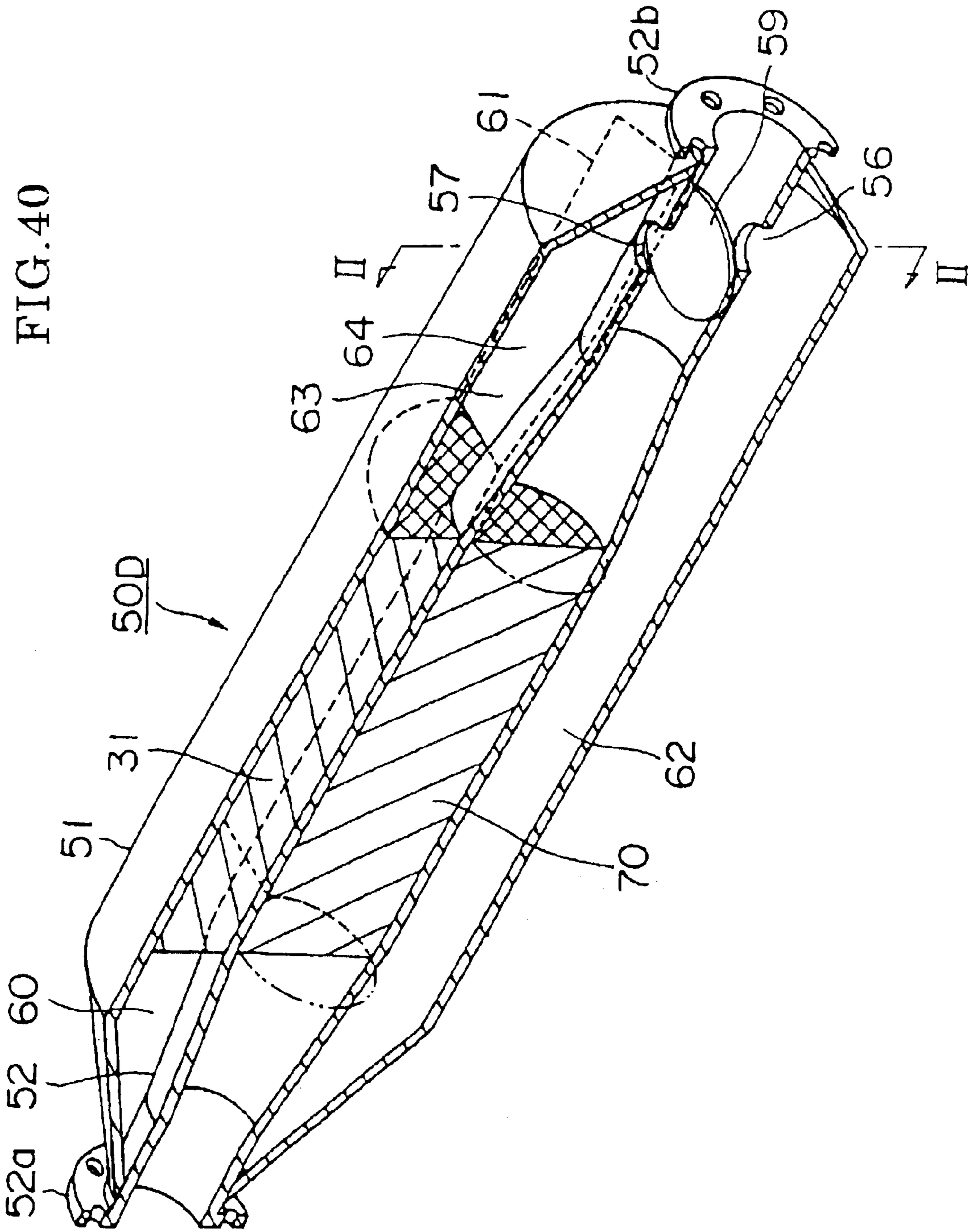

FIG.41

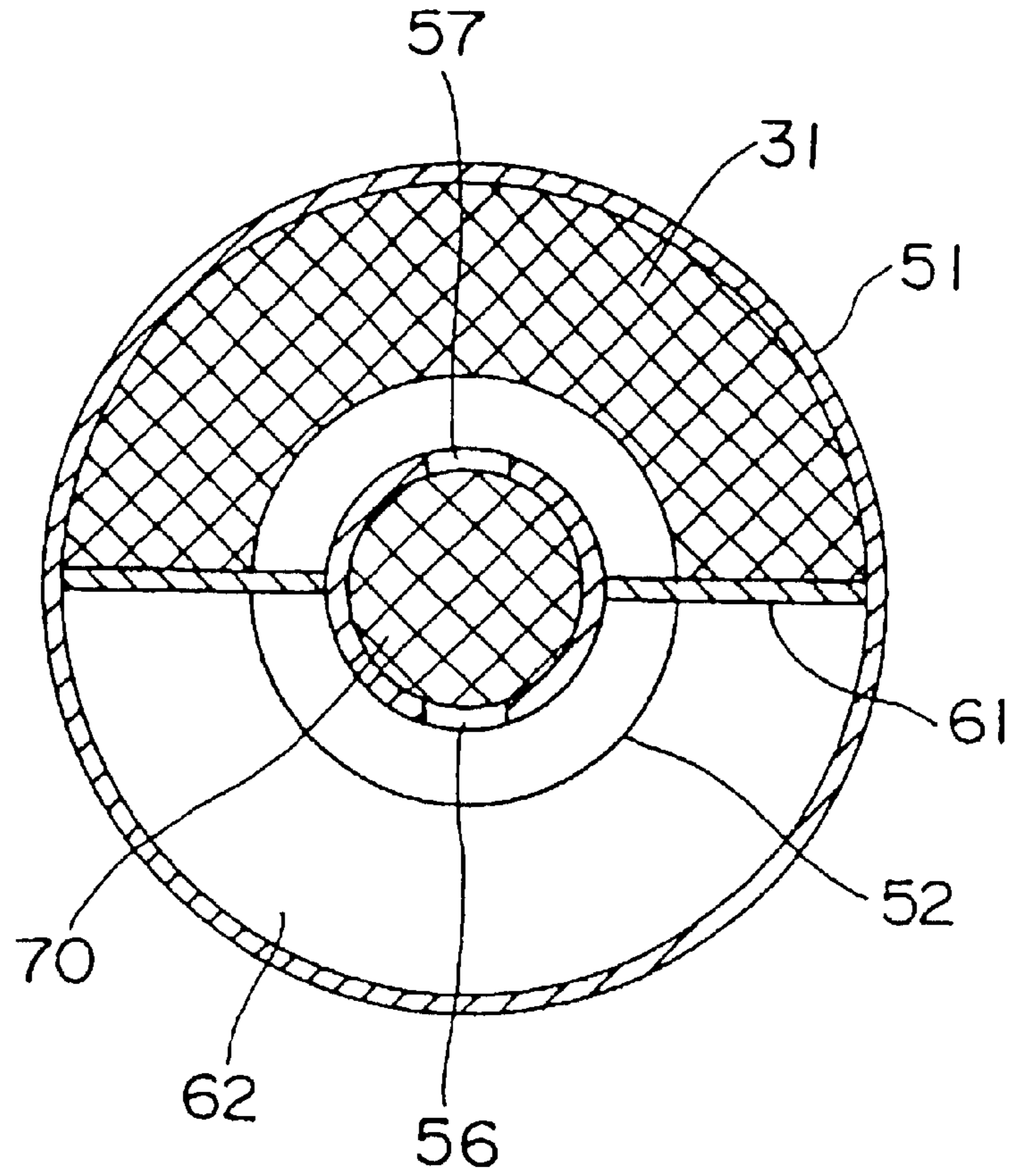

FIG.42

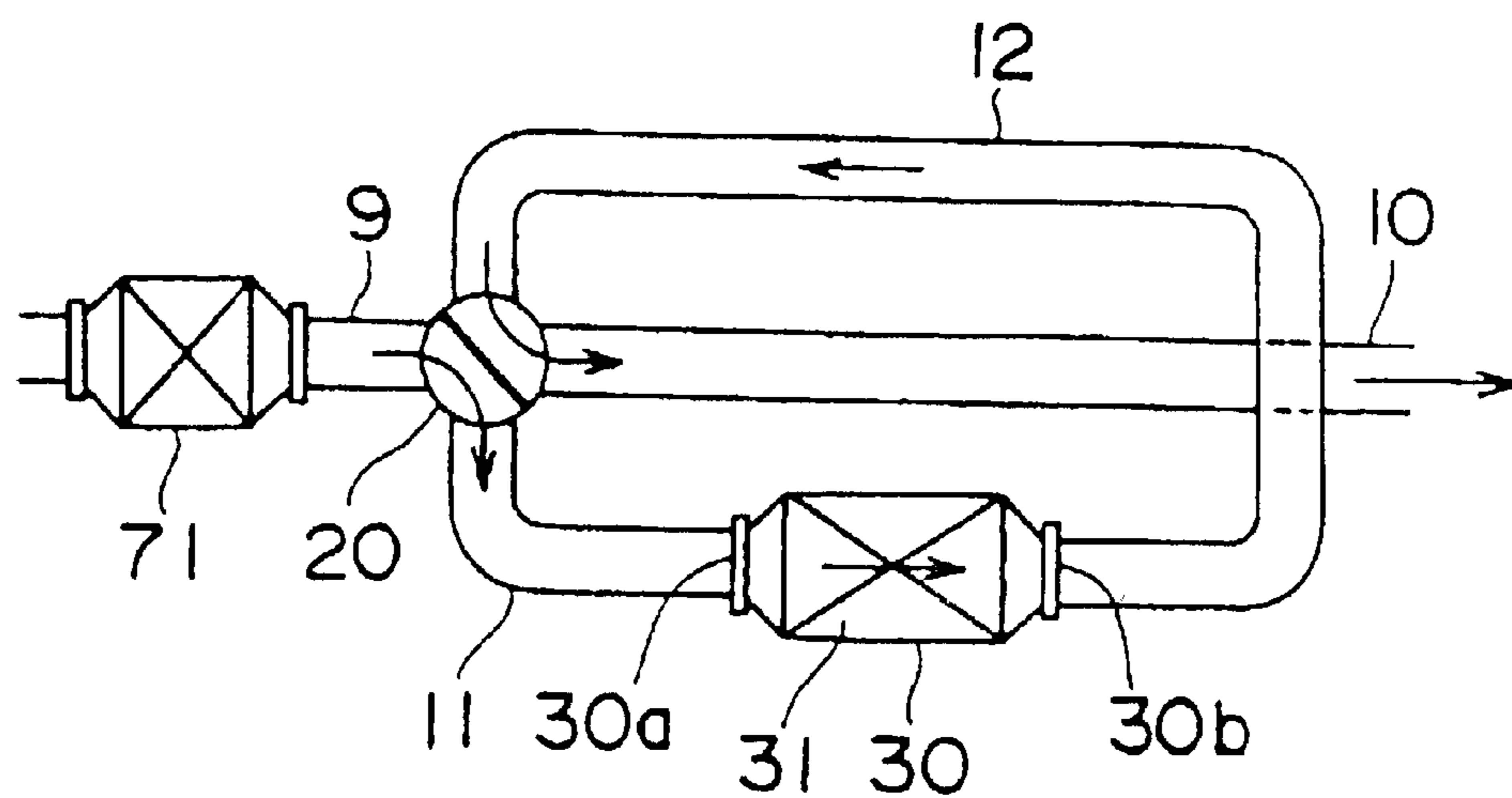

FIG.43

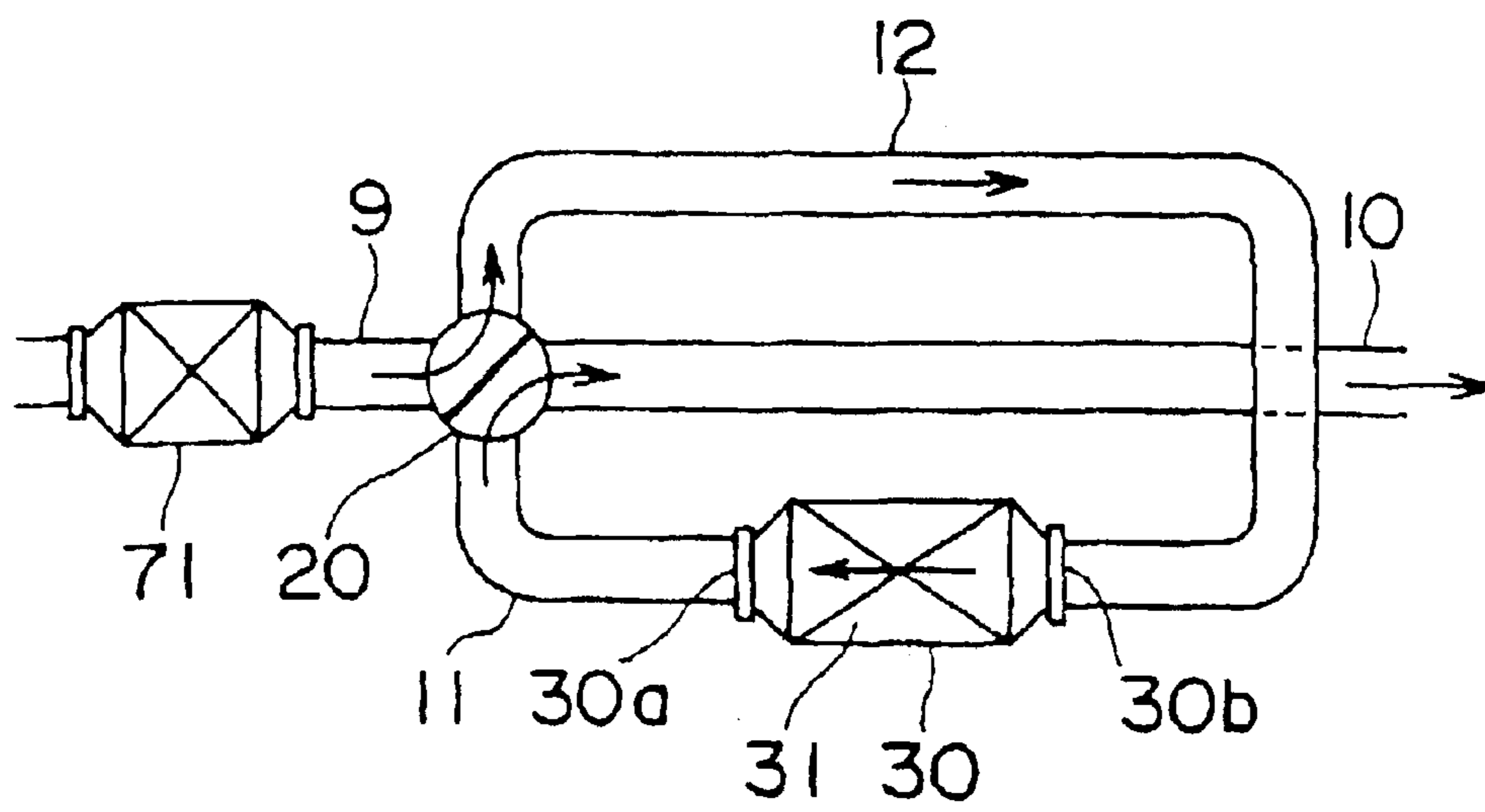

FIG.44

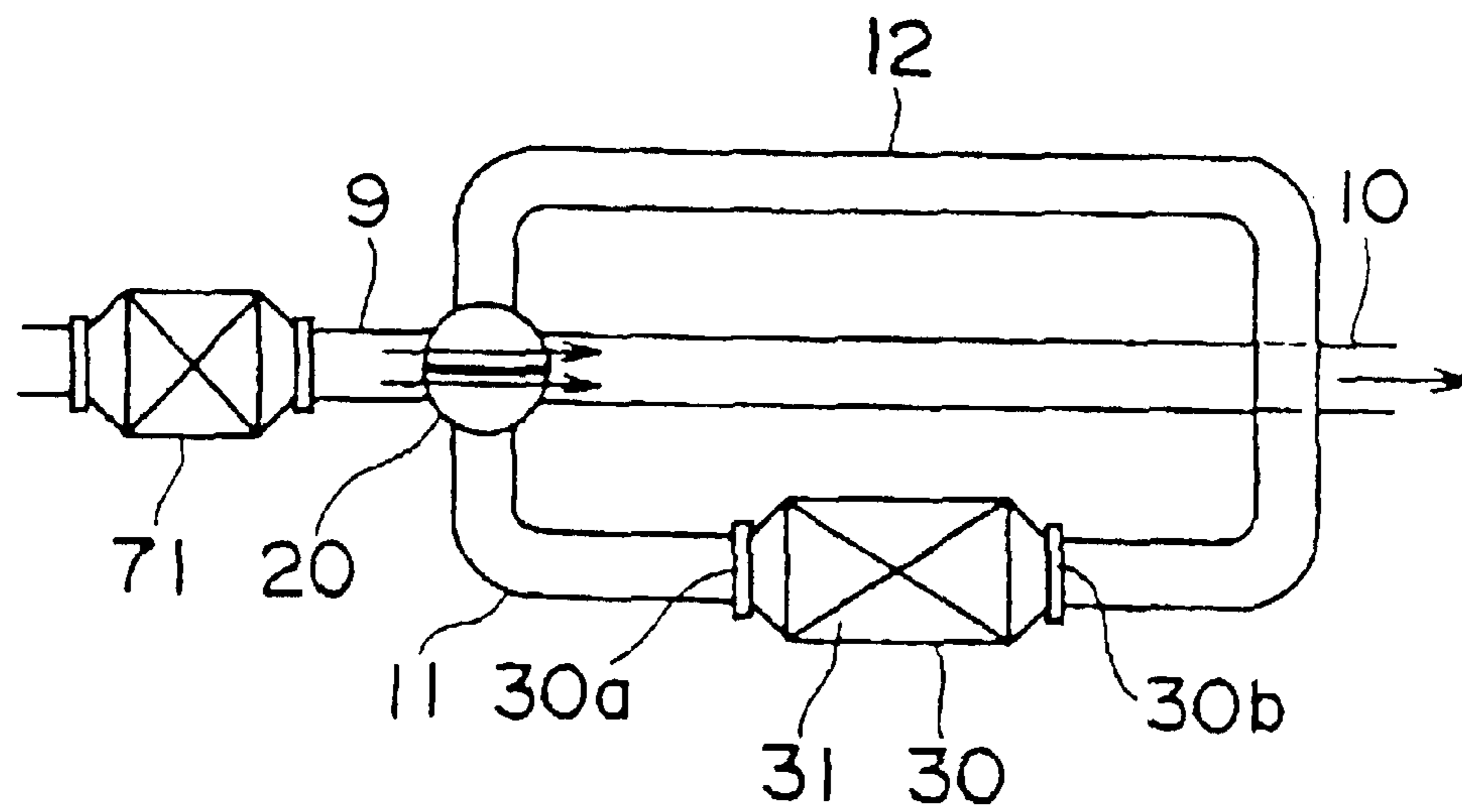

FIG. 45

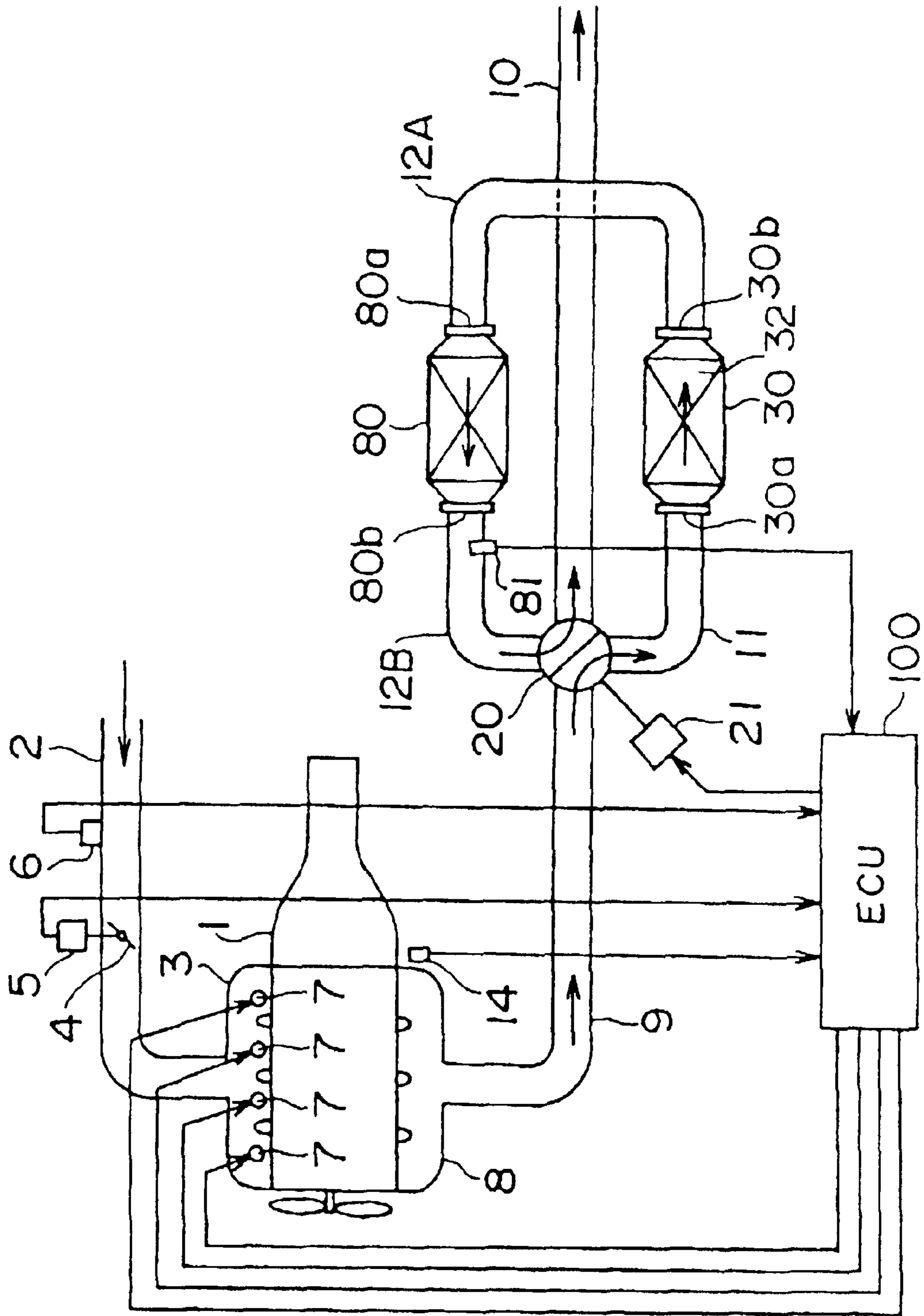
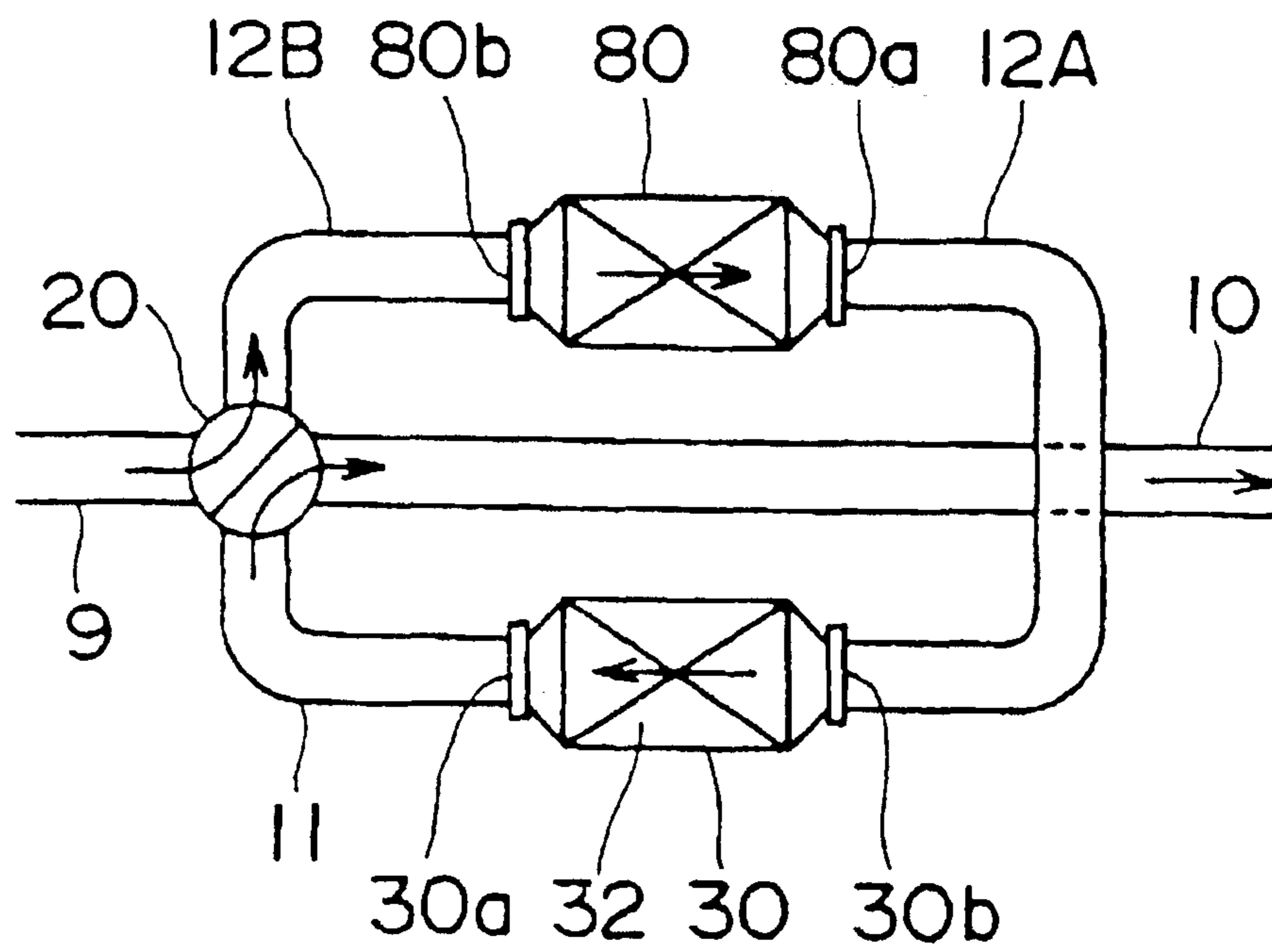

FIG. 46



EXHAUST EMISSION CONTROL SYSTEM OF AN INTERNAL COMBUSTION ENGINE

Matter enclosed in heavy brackets [] appears in the original patent but forms no part of this reissue specification; matter printed in italics indicates the additions made by reissue.

BACKGROUND OF THE INVENTION

1. Field of the Invention

The present invention relates generally to an exhaust emission control system of an internal combustion engine and, more particularly, to an exhaust emission control system of an internal combustion engine which is capable of switching over a flow direction of an exhaust gas flowing through an exhaust gas purifying element according to the necessity.

2. Related Background Art

In general, an exhaust emission control system for purifying an exhaust gas discharged from an internal combustion engine is provided at an exhaust passageway of the internal combustion engine. When the exhaust gas from the internal combustion engine flows through this exhaust emission control system, a deposit is gradually adhered from an upstream side in the exhaust emission control system. A classification of what this deposit is all about might differ depending upon a composition of the exhaust gas, or a construction of the exhaust emission control system or an exhaust gas purifying mechanism, and what can be exemplified as the deposit may be, e.g., an oxide, a sulfide, nitrate and sulfate. This deposit might cause a decline of a purging performance of the exhaust emission control system and also an increase in an exhaust resistance, and therefore needs to be removed at a predetermined timing.

For example, the exhaust emission control system for purging the exhaust gas of NO_x which is discharged from the internal combustion engine for performing a combustion at a lean air/fuel ratio, may involve the use of an NO_x storage-reduction catalyst. This NO_x storage-reduction catalyst absorbs NO_x when the air/fuel ratio of the inflow exhaust gas is lean, and desorbs NO_x absorbed thereto when a concentration of oxygen in the inflow exhaust gas decreases, thus effecting reduction to N_2 . The NO_x storage-reduction catalyst is disposed in an exhaust passageway, and absorbs a nitrogen oxide (NO_x) contained in the exhaust gas exhibiting the lean air/fuel ratio. After absorbing NO_x , the air/fuel ratio of the exhaust gas flowing into the NO_x storage-reduction catalyst is made rich by increasing a quantity of the fuel supplied to the internal combustion engine, thereby desorbing NO_x absorbed thereto from the NO_x storage-reduction catalyst. Desorbed NO_x is reduced to N_2 with a reducing component such as unburned HC, CO etc contained in the exhaust gas.

By the way, generally speaking, the fuel of the internal combustion engine contains a sulfur content, and, when the fuel is burned in the internal combustion engine, the sulfur content is burned, resulting in a production of sulfur oxide (SO_x). The NO_x storage-reduction catalyst absorbs SO_x contained in the exhaust gas with the same mechanism as absorbing NO_x . Therefore, if the NO_x storage-reduction catalyst is disposed in the exhaust passageway of the internal combustion engine, the NO_x storage-reduction catalyst absorbs SO_x as well as NO_x .

SO_x absorbed to the NO_x storage-reduction catalyst, however, generates stable sulfate with a passage of time. SO_x is therefore dissolved and desorbed with a difficulty and has

a tendency of being easily accumulated within the NO_x storage-reduction catalyst under a condition of executing desorption, reduction and purging of NO_x out of the NO_x storage-reduction catalyst (which is hereinafter termed a NO_x desorbing/reducing process). If there augments a SO_x accumulation quantity within the NO_x storage-reduction catalyst, a NO_x absorption quantity of the NO_x storage-reduction catalyst decreases, and it is therefore unfeasible to sufficiently purge the exhaust gas of NO_x , with the result that so-called SO_x poisoning occurs, wherein a NO_x purging rate declines. Such being the case, it is required that SO_x absorbed to the catalyst be desorbed therefrom at a proper timing in order to keep high the NO_x purging rate of the NO_x storage-reduction catalyst for a long period of time.

It has already proved that the air/fuel ratio of the inflow exhaust gas needs to be rich and the NO_x storage-reduction catalyst is required to be set at a higher temperature than in the NO_x desorbing/reducing process for desorbing SO_x absorbed to the NO_x storage-reduction catalyst.

Incidentally, a distribution of a SO_x absorption quantity in the NO_x storage-reduction catalyst exhibits a higher concentration in the closer proximity to the inlet of the exhaust gas in the NO_x storage-reduction catalyst. Hence, when desorbing SO_x absorbed to the NO_x storage-reduction catalyst, in the case of flowing the exhaust gas having the rich air/fuel ratio in the same direction as a flow direction of the exhaust gas when absorbing NO_x , though SO_x absorbed is desorbed on the inlet side in the NO_x storage-reduction catalyst, SO_x desorbed therefrom merely migrates to the outlet side of the exhaust gas through the NO_x storage-reduction catalyst and is reabsorbed to the NO_x storage-reduction catalyst. The problem is therefore such that SO_x can not be discharged from the NO_x storage-reduction catalyst.

Under such circumstances, a technology disclosed in Japanese Patent Application Laid-Open Publication No.7-259542, is that when desorbing SO_x absorbed to the NO_x storage-reduction catalyst, the exhaust gas having the rich air/fuel ratio flows through the NO_x storage-reduction catalyst in a direction opposite to the direction when absorbing NO_x . In the case of incorporating a backward flow function of desorbing SO_x by reversing the flow of the exhaust gas as described above, SO_x desorbed from the NO_x storage-reduction catalyst has a shorter migration distance within the NO_x storage-reduction catalyst, and is immediately discharged out of the NO_x storage-reduction catalyst. It is therefore feasible to prevent desorbed SO_x from being reabsorbed to the NO_x storage-reduction catalyst.

The following is an explanation of a construction of the exhaust emission control system of the internal combustion engine which incorporates the backward flow function disclosed in the above Publication. An upstream-side exhaust passageway connected to an inlet of the NO_x storage-reduction catalyst is connected to a downstream-side exhaust gas passageway connected to an outlet of the NO_x storage-reduction catalyst via a bypass passageway for bypassing the NO_x storage-reduction catalyst. A first emission flow switching valve is provided at a confluent portion between the upstream-side exhaust passageway and the bypass passageway. A second emission flow switching valve is provided at a confluent portion between the downstream-side exhaust passageway and the bypass passageway. The first emission flow switching valve is capable of making a changeover to let the exhaust gas flowing from upstream flow through the NO_x storage-reduction catalyst or let the exhaust gas flow into the bypass passageway. The second emission flow switching valve is capable of making a changeover to let the exhaust gas flowing through the NO_x

storage-reduction catalyst flow out toward the downstream-side exhaust passageway disposed more downstream than the second emission flow switching valve or let the exhaust gas flowing though the bypass passageway flow out toward the downstream-side exhaust passageway disposed more downstream than the second emission flow switching valve. Further, an exhaust passageway for suction is bypassed from the upstream-side exhaust passageway between the NO_x storage-reduction catalyst and the first emission flow switching valve, and is connected to an intake port of an exhaust pump, and a discharge port of the exhaust pump is connected to the above bypass passageway. Moreover, a reducing agent supply device for supplying a reducing agent is provided at the downstream-side exhaust passageway between the NO_x storage-reduction catalyst and the second emission flow switching valve.

Then, when in the NO_x absorbing process, the first and second emission flow switching valves are switched over to close the bypass passageway so that an entire quantity of exhaust gas from the internal combustion engine flows toward the outlet from the inlet of the NO_x storage-reduction catalyst. On the other hand, when desorbing SO_x from the NO_x storage-reduction catalyst, the first and second emission flow switching valves are switched over to close the bypass passageway so that substantially the entire quantity of exhaust gas from the internal combustion engine flows to the bypass passageway. Simultaneously, the exhaust gas in the upstream-side exhaust passageway between the NO_x storage-reduction catalyst and the first emission flow switching valve is sucked and discharged to the bypass passageway by operating the exhaust pump, thereby causing a flow of the exhaust gas flowing backward from the outlet toward the inlet through the NO_x storage-reduction catalyst. Besides, the reducing agent is supplied to the downstream-side exhaust passageway by operating a reducing agent supply device. The exhaust gas exhibiting the rich air/fuel ratio is thereby flowed backward through the NO_x storage-reduction catalyst, thus desorbing SO_x from the NO_x storage-reduction catalyst.

The conventional backward-flow-function-incorporated exhaust emission control system of the internal combustion engine requires the exhaust pump and the plurality of emission flow switching valves and therefore involves the use of an increased number of parts, resulting in a rise in costs. Further, the increased number of parts leads to a good deal of labors for maintenance and inspection, correspondingly.

Moreover, the SO_x desorbing process involving the backward flow in the NO_x storage-reduction catalyst may be defined as a processing method giving attention to avoidance of the SO_x reabsorption by decreasing the SO_x migration distance when desorbing SO_x. While on the other hand, if this processing method is adopted, there increases a distance till the exhaust gas arrives at the NO_x storage-reduction catalyst, and hence there must be a large drop in temperature of the exhaust gas during a period for which the exhaust gas flows through this long route. The above processing method is not necessarily, as the case may be, considered the best method of desorbing SO_x in terms of a temperature condition when desorbing SO_x.

SUMMARY OF THE INVENTION

It is a primary object of the present invention, which was devised to obviate the above problems inherent in the prior art, to provide an exhaust emission control system of an internal combustion engine, which is capable of reducing costs by simplifying its own structure and decreasing the number of parts thereof.

It is another object of the present invention to provide an exhaust emission control system of an internal combustion engine, which is capable of establishing a SO_x desorption processing technology with respect to an NO_x storage-reduction catalyst NO_x.

To accomplish the above objects, according to a first aspect of the present invention, an exhaust emission control system of an internal combustion engine comprises an exhaust gas purifying element provided in an exhaust passageway of the internal combustion engine, a flow direction switching device including four ports and provided at an exhaust passageway disposed more upstream than the exhaust gas purifying element, a first exhaust passageway connected to the internal combustion engine and further to a first portion of the flow direction switching device, a second exhaust passageway communicating with the atmospheric air and further to a second port of the flow direction switching device, a third exhaust passageway connected to one side of the exhaust gas purifying element and further to a third port of the flow direction switching device, and a fourth exhaust passageway connected to the other side of the exhaust gas purifying element and further to a fourth port of the flow direction switching element. The flow direction switching device can be switched over to a first position for permitting the exhaust gas to flow in a *first* direction through the exhaust gas purifying element by connecting the first port to the third port and connecting the second port to the fourth port, and to a second position for permitting the exhaust gas to flow in a direction opposite to the first direction through the exhaust gas purifying element by connecting the first port to the fourth port and connecting the second port to the third port.

In the thus constructed exhaust emission control system of the internal combustion engine, the flow direction switching device is selectively switched over to the first position or the second position, thereby making the exhaust gas flow in the forward or backward direction through the exhaust gas purifying element. A determination of a changeover of which flow direction the exhaust gas flows in when satisfying what condition, is made based on characteristics of the whole exhaust emission control system and of the exhaust gas purifying element.

A gasoline engine and a diesel engine may be exemplified as the internal combustion engine according to the present invention.

The exhaust gas purifying element according to the present invention may take any structures and forms on condition that it has a function of purifying the exhaust gas, and there may be exemplified a catalyst and a filter (e.g., a diesel particulate filter). Further, if there change a purifying mechanism of the exhaust gas purifying element and a composition of the exhaust gas from the internal combustion engine, an adhered substance adhered to the exhaust gas purifying element might differ in its classification. What is exemplified as the adhered substance may be an oxides, a sulfide, nitrate and sulfate.

Then, there may also be taken a using method of switching over the flow direction switching device in order to desorb the adhered substance adhered to the exhaust gas purifying device. In this case, it might be required that a temperature of the exhaust gas purifying device be raised when desorbing the adhered substance depending upon a type of the exhaust gas purifying device and the classification of the adhered substance, or that the air/fuel ratio of the exhaust gas be stoichiometric or rich, or that both of such operations be carried out.

5

According to a second aspect of the present invention, in the exhaust emission control system of the internal combustion engine according to the first aspect of the invention, the flow direction switching device can be switched over to a third position in which the first port is connectable to the second port. A determination of the way of using the flow direction switching device by setting this device in the third position and what state this should be done in, is made based on the characteristics of the whole exhaust emission control system and of the exhaust gas purifying element.

According to a third aspect of the present invention, in the exhaust emission control system of the internal combustion engine according to the first aspect of the invention, the exhaust gas purifying element may be an NO_x storage-reduction catalyst NO_x catalyst for absorbing NO_x when an air/fuel ratio of the inflow exhaust gas is lean, and desorbing NO_x absorbed thereto when a concentration of oxygen in the inflow exhaust gas decreases.

According to a fourth aspect of the present invention, in the exhaust emission control system of the internal combustion engine according to the third aspect of the invention, when in a SO_x desorbing process of desorbing SO_x absorbed to the NO_x storage-reduction catalyst from the NO_x storage-reduction catalyst, the flow direction switching device is switched over to the first position or the second position, thereby making a flow direction of the exhaust gas flowing through the NO_x storage-reduction catalyst opposite to the direction when absorbing NO_x.

This is based on such a conception that the exhaust gas flows through the NO_x storage-reduction catalyst, and SO_x contained in the exhaust gas is adhered to the NO_x storage-reduction catalyst, in which case the SO_x absorption starts from an upstream portion of the NO_x storage-reduction catalyst, and the SO_x-absorbed area gradually expands toward the downstream side. If SO_x is thus distributed over the NO_x storage-reduction catalyst, when in the SO_x desorbing process, SO_x can be desorbed from the NO_x storage-reduction catalyst at a high efficiency by flowing the exhaust gas in the direction opposite to the direction when absorbing NO_x. Note that when in the SO_x desorbing process, the air/fuel ratio of the exhaust gas is set stoichiometric or rich. Further, when in the SO_x desorbing process, it is preferable that the exhaust gas temperature or the temperature of the NO_x storage-reduction catalyst be high to enable the SO_x desorption to be executed at the high efficiency.

According to a fifth aspect of the present invention, in the exhaust emission control system of the internal combustion engine according to the fourth aspect of the invention, the exhaust gas purifying element composed of the NO_x storage-reduction catalyst is such that, a NO_x storage-reduction catalyst disposed on inlet side in the flow direction of the exhaust gas when absorbing NO_x exhibits higher SO_x absorbing power than that of an NO_x storage-reduction catalyst disposed on an outlet side in the flow direction of the exhaust gas when absorbing NO_x. With this contrivance, a greater amount of SO_x is adhered on the inlet side of the exhaust gas when absorbing NO_x in the NO_x storage-reduction catalyst [NO_x catalyst,] and, when in the SO_x desorbing process executed by reversing the flow direction of the exhaust gas, SO_x is desorbed at a higher efficiency from the NO_x storage-reduction catalyst.

According to a sixth aspect of the present invention, the exhaust emission control system of the internal combustion engine according to the fourth aspect of the invention, may further comprise a heating element for heating a portion close to an inlet of the NO_x storage-reduction catalyst in the

6

flow direction of the exhaust gas when the NO_x storage-reduction catalyst absorbs NO_x. With this construction, the SO_x desorption out of the NO_x storage-reduction catalyst is more speeded up.

According to a seventh aspect of the present invention, in the exhaust emission control system of the internal combustion engine according to the fourth aspect of the invention, the switch-over of the flow direction switching device when in the SO_x desorbing process is executed when an exhaust gas temperature or a catalytic temperature of the NO_x storage-reduction catalyst rises. The NO_x storage-reduction catalyst has a nature of easily absorbing NO_x and SO_x when the exhaust gas temperature lowers, and desorbing NO_x and SO_x when the exhaust gas temperature rises, and hence the SO_x desorption is facilitated by taking the above switching timing.

The switching timing by the flow direction switching device is not, however, limited to what has been described above. The switching timing may also include a timing when a quantity of SO_x absorbed to the NO_x storage-reduction catalyst reaches a predetermined quantity. Further, if applied to a gasoline engine (a so-called lean-burn gasoline engine) capable of performing the combustion at a lean air/fuel ratio, the combustion in the engine can be switched over to a combustion at the lean air/fuel ratio and to a combustion at a rich air/fuel ratio, depending upon an operation state of the engine. Hence, the changeover of the flow direction switching device may be controlled corresponding to the operation state of the engine.

According to an eighth aspect of the present invention, in the exhaust emission control system of the internal combustion engine according to the fourth aspect of the invention, lengths of the third exhaust passageway and of the fourth exhaust passageway are set so that a distance from the internal combustion engine to the NO_x storage-reduction catalyst is shorter [when absorbing NO_x than when in the SO_x desorbing process] when in the SO_x desorbing process when absorbing NO_x by switching over the flow direction switching device to the first position or the second position. With this contrivance, it is feasible to minimize a drop in the exhaust gas temperature till the exhaust gas arrives at the NO_x storage-reduction catalyst during the SO_x desorbing process and to speed up the rise in the temperature of the NO_x storage-reduction catalyst. As a result, the SO_x desorption can be speeded up.

According to a ninth aspect of the present invention, in the exhaust emission control system of the internal combustion engine according to the third aspect of the invention, a sweeper may be provided at the second exhaust passageway. With this configuration, even when the flow of the exhaust gas is bypassed without flowing through the exhaust gas purifying element in the process of the switching-over of the flow direction switching device, the exhaust gas is purified by the sweeper and is discharged into the atmospheric air.

According to a tenth aspect of the present invention, in the exhaust emission control system of the internal combustion engine according to the ninth aspect of the invention, the sweeper is a selective reduction type NO_x catalyst for reducing or dissolving NO_x under an existence of hydro carbon in an over-oxygen atmosphere.

According to an eleventh aspect of the present invention, in the exhaust emission control system of the internal combustion engine according to the ninth aspect of the invention, another catalyst may be provided in the first exhaust passageway, and the flow direction switching device may be switched over to the third position for connecting the first

port to the second port for an initial predetermined time during the SO_x desorbing process and, after the predetermined time has elapsed, switched over to make the flow direction of the exhaust gas flowing through the NO_x storage-reduction catalyst opposite to the direction when absorbing NO_x . With this contrivance, even when SO_x is desorbed from another catalyst at an initial stage of the SO_x desorbing process, SO_x desorbed therefrom does not flow to the NO_x storage-reduction catalyst, whereby the NO_x storage-reduction catalyst can be prevented from suffering SO_x poisoning. Besides, the sweeper can purge the exhaust gas of SO_x desorbed out of another catalyst.

According to a twelfth aspect of the present invention, in the exhaust emission control system of the internal combustion engine according to the ninth aspect of the invention, the NO_x storage-reduction catalyst and the sweeper are integrated into one unit so that the exhaust gas can not flow therebetween and the heat can be transmitted therebetween. With this construction, a temperature of the sweeper can be kept high.

According to a thirteenth aspect of the present invention, in the exhaust emission control system of the internal combustion engine according to the first aspect of the invention, lengths of the third exhaust passageway and of the fourth exhaust passageway are set so that a distance from the internal combustion engine to the exhaust gas purifying element becomes different by switching over the flow direction switching device to the first position or the second position. With this setting, the drop in the temperature of the exhaust gas flowing into the exhaust gas purifying element can be made smaller when selecting the flow path having the shorter distance from the internal combustion engine to the exhaust gas purifying element than when selecting the flow path having the longer distance. A determination of what state the flow direction switching device switches over the flow direction of the exhaust gas, is made based on the characteristics of the whole exhaust emission control system and of the exhaust gas purifying element.

According to a fourteenth aspect of the present invention, in the exhaust emission control system of the internal combustion engine according to the thirteenth aspect of the invention, the switch-over of the flow direction switching device is executed based on an exhaust gas temperature or a temperature of the exhaust gas purifying element. A determination about what temperature condition the flow direction switching device switches over the flow direction of the exhaust gas, is made based on the characteristics of the whole exhaust emission control system and of the exhaust gas purifying element.

According to a fifteenth aspect of the present invention, in the exhaust emission control system of the internal combustion engine according to the fourteenth aspect of the invention, the exhaust gas purifying element may be an NO_x storage-reduction catalyst NO_x catalyst for absorbing NO_x when an air/fuel ratio of the inflow exhaust gas is lean, and desorbing NO_x absorbed thereto when a concentration of oxygen in the inflow exhaust gas decreases.

According to a sixteenth aspect of the present invention, in the exhaust emission control system of the internal combustion engine according to the fifteenth aspect of the invention, the flow direction switching device is switched over by selecting a flow path having a shorter distance from the internal combustion engine to the NO_x storage-reduction catalyst when in the SO_x desorbing process of desorbing SO_x desorbed to the NO_x storage-reduction catalyst from the NO_x storage-reduction catalyst. In the case of desorbing SO_x

from the NO_x storage-reduction catalyst, a SO_x desorbing efficiency is higher when the temperature of the NO_x storage-reduction catalyst is higher. When selecting the flow path having the shorter distance from the internal combustion engine to the NO_x storage-reduction catalyst, there is decreased the drop in the exhaust gas temperature till the exhaust gas arrives at the NO_x storage-reduction catalyst, and the higher-temperature exhaust gas can flow into the NO_x storage-reduction catalyst. As a result, SO_x can be desorbed more efficiently.

According to a seventeenth aspect of the present invention, in the exhaust emission control system of the internal combustion engine according to the fifteenth aspect of the invention, the flow direction switching device may be switched over by selecting a flow path having a longer distance from the internal combustion engine to the NO_x storage-reduction catalyst when the NO_x storage-reduction catalyst absorbs NO_x and when the exhaust gas temperature or the catalytic temperature of the NO_x storage-reduction catalyst is over a predetermined temperature, and selecting a flow path having a shorter distance from the internal combustion engine to the NO_x storage-reduction catalyst when the NO_x storage-reduction catalyst absorbs NO_x and when the exhaust gas temperature or the catalytic temperature is lower than the predetermined temperature. If the distance from the internal combustion engine to the NO_x storage-reduction catalyst is long, there must be a large drop in the temperature of the exhaust gas till the exhaust gas arrives at the NO_x storage-reduction catalyst. Reversely, if the distance from the internal combustion engine to the NO_x storage-reduction catalyst is short, there must be a small drop in the temperature of the exhaust gas till the exhaust gas arrives at the NO_x storage-reduction catalyst. Accordingly, the long route and the short route are separately used by switching over the flow direction switching device as described above, whereby the NO_x storage-reduction catalyst can be kept within a temperature range preferable to the NO_x absorption, and the NO_x purging rate can be enhanced.

According to an eighteenth aspect of the present invention, in the exhaust emission control system of the internal combustion engine according to the fifteenth aspect of the invention, a sweeper may be provided at the second exhaust passageway, and the flow direction switching device can be switched over to a third position in which the first port can be connected to the second port. When *the exhaust gas temperature* or the catalytic temperature of the NO_x storage-reduction catalyst is higher than a NO_x absorbable temperature range of the NO_x storage-reduction catalyst, the flow direction switching device may be selectively switched over to the third position. If *the exhaust gas temperature* or the catalytic temperature of the NO_x storage-reduction catalyst is higher than the NO_x absorbable temperature range of the NO_x storage-reduction catalyst, the exhaust gas is not purged of NO_x contained therein [eve] by flowing the exhaust gas through the NO_x storage-reduction catalyst, and besides the NO_x storage-reduction catalyst is deteriorated due to the high temperature. Then, in such a case, the flow direction switching device is switched over to the third position, whereby the exhaust gas takes a short path from the first exhaust passageway to the second exhaust passageway without flowing through the NO_x storage-reduction catalyst. The NO_x storage-reduction catalyst is thereby prevented from being deteriorated. Further, the sweeper purges the exhaust gas of HC and CO contained therein.

According to a nineteenth aspect of the present invention, in the exhaust emission control system of the internal combustion engine according to the seventeenth aspect of the

invention, a cooling device for cooling the exhaust gas may be provided at either the third exhaust passageway or the fourth exhaust passageway, which increases the distance from the internal combustion engine to the NO_x storage-reduction catalyst. The cooling device is capable of forcibly cooling the exhaust gas, which enables the NO_x storage-reduction catalyst to be more surely kept within the temperature range preferable to the NO_x absorption.

According to a twentieth aspect of the present invention, in the exhaust emission control system of the internal combustion engine according to the third aspect of the invention, the first exhaust passageway may be provided with a SO_x absorbing agent for absorbing SO_x when the air/fuel ratio of the inflow exhaust gas is lean, and desorbs SO_x absorbed thereto when a concentration of oxygen in the inflow exhaust gas decreases. The flow direction switching device can be switched over to the third position in which to connect the first port to the second port, and may be selectively switched over to the third position when the internal combustion engine comes to a continuous stoichiometric ratio operation. The internal combustion engine comes into the continuous stoichiometric ratio operation, and the exhaust gas having the stoichiometric ratio flows into the SO_x absorbing agent. Then, SO_x is desorbed from the SO_x absorbing agent, and at this time the flow direction switching device is switched over to the third position, with the result that the exhaust gas containing SO_x desorbed from the SO_x adsorbing agent flows along the short path from the first exhaust passageway to the second exhaust passageway and is charged into the atmospheric air without flowing into the NO_x storage-reduction catalyst. Accordingly, the NO_x storage-reduction catalyst can be prevented from the SO_x poisoning.

According to a twenty first aspect of the present invention, in the exhaust emission control system of the internal combustion engine according to the twentieth aspect of the invention, the SO_x absorbing agent and the NO_x storage-reduction catalyst may be concentrically disposed. With this arrangement, the exhaust emission control system can be made compact.

According to twenty second aspect of the present invention, in the exhaust emission control system of the internal combustion engine according to the third aspect of the invention, the first exhaust passageway may be provided with a three-way catalyst exhibiting SO_x absorbing power, and the flow direction switching device can be switched over to the third position in which the first port is connectable to the second port, and may be selectively switched over to the third position when the internal combustion engine comes to a continuous stoichiometric ratio operation. The internal combustion engine comes into the continuous stoichiometric ratio operation, and the exhaust gas having the stoichiometric ratio flows into the three-way catalyst exhibiting the SO_x absorbing power, whereby SO_x is desorbed from the three-way catalyst. At this time, however, if the flow direction switching valve is switched over to the third position as described above, the exhaust gas containing SO_x desorbed from the three-way catalyst takes the short path from the first exhaust passageway to the second exhaust passageway and is charged into the atmospheric air without flowing into the NO_x storage-reduction catalyst. Hence, the NO_x storage-reduction catalyst can be prevented from the SO_x poisoning. Further, at this time, the exhaust gas is purified by three-way activation of the three-way catalyst.

According to a twenty third aspect of the present invention, in the exhaust emission control system of the internal combustion engine according to the first aspect of the invention, the exhaust gas purifying element may be a

catalyst, any one of the third exhaust passageway and the fourth exhaust passageway is provided with an HC adsorbing agent for adsorbing hydro carbon, and the flow direction switching device may be switched over to select a flow path on which the catalyst is positioned more upstream than the HC adsorbing agent when the temperature of the exhaust gas or of the HC adsorbing agent is in a temperature region where the HC adsorbing agent adsorbs the hydro carbon, and to select a flow path on which the HC adsorbing agent is positioned more upstream than the catalyst when the temperature of the exhaust gas or of the HC adsorbing agent is in a temperature region where the HC adsorbing agent desorbs the hydro carbon. With this contrivance, when the exhaust gas temperature or the temperature of the HC [adsorbing] adsorbing agent is in the temperature region where the HC [adsorbing] adsorbing agent adsorbs the hydro carbon, HC is adsorbed to the HC adsorbing agent even if the catalyst is not activated and HC contained in the exhaust gas flows through the catalyst. Moreover, when the exhaust gas temperature or the temperature of the HC [adsorbing] adsorbing agent is in the temperature region where the HC [adsorbing] adsorbing agent desorbs the hydro carbon, HC is desorbed from the HC adsorbing agent when the exhaust gas flows through the HC adsorbing agent. Furthermore, the exhaust gas is purged of HC when passing through the catalyst of which a temperature reaches an active temperature.

These together with other objects and advantages which will be subsequently apparent, reside in the details of construction and operation as more fully hereinafter described and claimed, reference being had to the accompanying drawings forming a part hereof, wherein like numerals refer to like parts throughout.

BRIEF DESCRIPTION OF THE DRAWINGS

Other objects and advantages of the present invention will become apparent during the following discussion in conjunction with the accompanying drawings, in which:

FIG. 1 is a schematic diagram of a construction of an exhaust emission control system of an internal combustion engine in a first embodiment of the present invention, showing a state where an emission switching valve is located in a forward flow direction;

FIG. 2 is a diagram showing principal components of the exhaust emission control system in the first embodiment when the emission switching valve is located in a backward flow position;

FIG. 3 is an explanatory diagram showing NO_x absorbing/desorbing/reducing action of an NO_x storage-reduction catalyst;

FIG. 4 is a diagram showing the principal components of the exhaust emission control system in the first embodiment when the emission switching valve is located in a neutral position between the forward flow position and the backward flow position;

FIG. 5 is a diagram showing the principal components of the exhaust emission control system in a modified example of the first embodiment when the emission switching valve is located in the forward flow position;

FIG. 6 is a diagram showing the principal components of the exhaust emission control system in the modified example of the first embodiment when the emission switching valve is located in the forward flow position;

FIG. 7 is a diagram showing the principal components of the exhaust emission control system in the modified example of the first embodiment when the emission switching valve is located in the forward flow position;

11

FIG. 8 is a diagram showing the principal components of the exhaust emission control system in the modified example of the first embodiment when the emission switching valve is located in the forward flow position;

FIG. 9 is a diagram showing the principal components in the modified example shown in FIG. 8 when a valve member is located in the backward flow position;

FIG. 10 is a perspective cutaway view of the modified example shown in FIG. 8;

FIG. 11 is a detailed perspective view with a portion cutaway in the vicinity of the valve member in the modified example shown in FIG. 8;

FIG. 12 is a diagram showing the principal components of the exhaust emission control system in the modified example of the first embodiment when the valve member is located in the forward flow position;

FIG. 13 is a diagram showing the principal components in the modified example shown in FIG. 12 when the valve member is located in the backward flow position;

FIG. 14 is a perspective cutaway view of the modified example shown in FIG. 12;

FIG. 15 is a sectional view taken in the arrow direction I—I in FIG. 14;

FIG. 16 is a diagram showing the principal components of the exhaust emission control system of the internal combustion engine in a second embodiment of the present invention when the emission switching valve is located in the forward flow position;

FIG. 17 is a diagram showing the principal components of the exhaust emission control system in a modified example of the second embodiment when the emission switching valve is located in the forward flow position;

FIG. 18 is a diagram showing the principal components of the exhaust emission control system in the modified example of the second embodiment when the emission switching valve is located in the backward flow position;

FIG. 19 is a diagram showing the principal components of the exhaust emission control system in another modified example of the second embodiment when the emission switching valve is located in the forward flow position;

FIG. 20 is a diagram showing the principal components of the exhaust emission control system in a third embodiment of the present invention when the emission switching valve is located in the forward flow position;

FIG. 21 is a diagram showing the principal components of the exhaust emission control system in a modified example of the third embodiment when the emission switching valve is located in the backward flow position;

FIG. 22 is a diagram showing the principal components of the exhaust emission control system of the present invention in a fourth embodiment of the present invention when the emission switching valve is located in the forward flow position;

FIG. 23 is a diagram showing the principal components of the exhaust emission control system in the fourth embodiment when the emission switching valve is located in the neutral position between the forward flow position and the backward flow position;

FIG. 24 is a diagram showing the principal components of the exhaust emission control system in a fifth embodiment of the present invention when the emission switching valve is located in the forward flow position;

FIG. 25 is a diagram showing the principal components of the exhaust emission control system in a modified example

12

of the fifth embodiment when the emission switching valve is located in the forward flow position;

FIG. 26 is a schematic diagram showing a construction of the exhaust emission control system in a sixth embodiment of the present invention when the emission switching valve is located in the forward flow position;

FIG. 27 is a diagram showing the principal components of the exhaust emission control system in sixth embodiment when the emission switching valve is located in the backward flow position;

FIG. 28 is a diagram showing a temperature characteristic between the NO_x storage-reduction catalyst NO_x catalyst and a NO_x purging rate;

FIG. 29 is a diagram showing the principal components of the exhaust emission control system of the present invention in a seventh embodiment of the present invention when the emission switching valve is located in the forward flow position;

FIG. 30 is a diagram showing the principal components of the exhaust emission control system in the seventh embodiment when the emission switching valve is located in the neutral position between the forward flow position and the backward flow position;

FIG. 31 is a diagram showing the principal components of the exhaust emission control system in an eighth embodiment of the present invention when the emission switching valve is located in the backward flow position;

FIG. 32 is a schematic diagram showing a configuration of the exhaust emission control system in a ninth embodiment of the present invention when the valve member is located in the forward flow position;

FIG. 33 is a diagram showing the principal components of the exhaust emission control system in ninth embodiment when the valve member is located in the backward flow position;

FIG. 34 is a diagram showing the principal components of the exhaust emission control system in the ninth embodiment when the emission switching valve is located in the neutral position between the forward flow position and the backward flow position;

FIG. 35 is a diagram with the principal components cutaway in the exhaust emission control system in the ninth embodiment;

FIG. 36 is a detailed perspective view with a portion cutaway in the vicinity of the valve member of the exhaust emission control system in the ninth embodiment;

FIG. 37 is a diagram showing the principal components of the exhaust emission control system in the modified example of the ninth embodiment when the valve member is located in the forward flow position;

FIG. 38 is a diagram showing the principal components in the modified example shown in FIG. 37 when the valve member is located in the backward flow position;

FIG. 39 is a diagram showing the principal components in the modified example illustrated in FIG. 37 when the valve member is located in the neutral position between the forward flow position and the backward flow position;

FIG. 40 is a perspective view with the principal components cutaway in the modified example shown in FIG. 37;

FIG. 41 is a sectional view taken in the arrow direction II—II in FIG. 40;

FIG. 42 is a diagram showing the principal components of the exhaust emission control system in the ninth embodiment when the emission switching valve is located in the forward flow position;

13

FIG. 43 is a diagram showing the principal components in the modified example shown in FIG. 42 when the emission switching valve is located in the backward flow position;

FIG. 44 is a diagram showing the principal components in the modified example shown in FIG. 42 when the emission switching valve is located in the neutral position between the forward flow position and the backward flow position;

FIG. 45 is a schematic diagram showing a construction of the exhaust emission control system in a tenth embodiment of the present invention when the emission switching valve is located in the forward flow position; and

FIG. 46 is a diagram showing the principal components of the exhaust emission control system in the tenth embodiment of the present invention when the emission switching valve is located in the backward flow position.

DESCRIPTION OF THE PREFERRED EMBODIMENTS

Embodiments of an exhaust emission control system of an internal combustion engine according to the present invention will hereinafter be described with reference to FIGS. 1 through 46.

First Embodiment

FIG. 1 is a diagram schematically showing a construction of the exhaust emission control system of the internal combustion engine according to the present invention in an embodiment where the same control system is applied to a gasoline engine (a so-called lean-burn gasoline engine) capable of burning at a lean air/fuel ratio.

Referring to FIG. 1, an engine 1 is classified as a straight-four-cylinder engine, wherein intake air is supplied to each of the cylinders via an intake pipe 2 and an intake manifold 3. The intake pipe 2 is provided with a throttle valve 4 for opening and closing an intake passageway within the intake pipe 2, interlocking with an unillustrated accelerator pedal. Attached to this throttle valve 4 is a throttle position sensor 5 for outputting an output signal corresponding to an aperture of the throttle valve 4 to an engine-control-oriented electronic control unit (ECU) 100.

An airflow meter 6 for outputting to the ECU 100 an output signal corresponding to an intake air quantity (intake air mass) Q of the air flowing inside the intake pipe 2, is attached to the intake pipe 2 more upstream than the throttle valve 4 along the intake pipe 2.

A fuel (gasoline) is injected out of a fuel injection valve 7 into each intake passageway communicating with each cylinder. A valve closing timing and a valve opening period of the fuel injection valve 7 are controlled by the ECU 100 in accordance with an operation state of the engine 1.

An exhaust gas discharged from each cylinder of the engine 1 is exhausted via an exhaust manifold 8 and an exhaust pipe (a first exhaust passageway) 9. The exhaust pipe 9 is connected to a first port of an emission switching valve (a switching unit) 20 formed with four ports. A second port of the emission switching valve 20 is connected to an exhaust pipe (a second exhaust passageway) 10 for discharging the exhaust gas into the atmospheric air. A third port of the emission switching valve 20 is connected to an inlet 30a of a catalytic converter (an exhaust gas purifying unit) 30 via an exhaust pipe (a third exhaust passageway) 11. A fourth port of the emission switching valve 20 is connected to an outlet 30b of the catalytic converter 30 via an exhaust pipe (a fourth exhaust passageway) 12. The catalytic converter 30 contains an NO_x storage-reduction catalyst (hereinafter

14

abbreviated to the NO_x catalyst) 31. The NO_x catalyst 31 will be explained in greater details later on.

The emission switching valve 20 is capable of changing a *direction* of the exhaust gas flowing through the catalytic converter 30 by switching a valve member thereof to a forward flow position shown in FIG. 1 and to a backward flow position shown in FIG. 2. When the valve member is located in the forward flow position, the emission switching valve 20 connects the exhaust pipe 9 to the exhaust pipe 11, and connects the exhaust pipe 10 to the exhaust pipe 12, at which time the exhaust gas flows in the sequence such as the exhaust pipe 9→the exhaust pipe 11→the catalytic converter 30→the exhaust pipe 12→the exhaust pipe 10, and is released into the atmospheric air. What is referred to as a “forward flow” in the following discussion is a flow of the exhaust gas flowing from the inlet 30a of the catalytic converter 30 toward the outlet 30b thereof. Further, when the valve member of the emission switching valve 20 is located in the backward flow position shown in FIG. 2, the emission switching valve 20 connects the exhaust pipe 9 to the exhaust pipe 12, and connects the exhaust pipe 10 to the exhaust pipe 11, at which time the exhaust gas flows in the sequence such as the exhaust pipe 9→the exhaust pipe 12→the catalytic converter 30→the exhaust pipe 11→the exhaust pipe 10, and is released into the atmospheric air. What is referred to as a “backward flow” in the following discussion is a flow of the exhaust gas flowing from the outlet 30b of the catalytic converter 30 toward the inlet 30a thereof.

This emission switching valve 20 is driven by an actuator 21, thereby switching a position of the valve member, and the actuator 21 is controlled by the ECU 100. In this embodiment, the actuator 21 and the ECU 100 are combined to constitute a control module. The switching control of the position of the valve member of the emission switching valve 20 will be discussed hereinafter in greater details.

An exhaust gas temperature sensor 13 for outputting to the ECU 100 an output signal corresponding to a temperature of the exhaust gas flowing within the exhaust pipe 11, is attached to the exhaust pipe 11 in the vicinity of the inlet 30a of the catalytic converter 30.

The digital-computer-based ECU 100 includes a ROM (Read-Only Memory), a RAM (Random Access Memory), a CPU (Central Processing Unit), an input port and an output port, which are connected to each other via a bidirectional bus. The ECU 100 performs basic control processes such as controlling the air/fuel ratio of the engine 1 and besides an SO_x desorbing process control of the catalytic converter 30.

Inputted to the input port of the ECU 100 for these control processes are an input signal from the airflow meter 6, an input signal from the exhaust gas temperature sensor 13 and in addition an input signal from an engine speed sensor 14. The engine speed sensor 14 outputs to the ECU 100 an output signal corresponding to an engine speed of the engine 1, and the ECU 100 calculates an engine speed N on the basis of this output signal. Further, the ECU 100 calculates an intake air quantity Q from the output signal of the airflow meter 6, and thereby calculates an engine load Q/N (intake air quantity Q /engine speed N). Then, the ECU 100 judges an operation state of the engine 1 from the engine load Q/N as well as from the engine speed N , and controls a quantity of the fuel injected from the fuel injection valve in accordance with the operation state, thus controlling the air/fuel ratio to a lean air/fuel ratio and a stoichiometric ratio or a rich air/fuel ratio. One exemplification of this air/fuel ratio control is a control method by which the air/fuel ratio is set

to the stoichiometric ratio or the rich air/fuel ratio when in a warm-up operation and in a high-load operation region, and set to the lean air/fuel ratio in a low- and middle-load operation region.

The NO_x catalyst **31**, i.e., the NO_x storage-reduction catalyst contained in the catalytic converter **30** involves the use of, e.g., aluminum serving as a carrier. Elements borne on this carrier are at least one element chosen from alkali metals such as, e.g., potassium K, sodium Na, lithium Li and cesium Cs, alkaline earth elements such as barium Ba and calcium Ca, and rare and rare earth elements such as lanthanum La and yttrium Y, and a precious metal such as platinum Pt.

This NO_x catalyst **31** absorbs NO_x when the air/fuel ratio of the inflow exhaust gas (which is hereinafter be referred to as an exhaust air/fuel ratio) is lean, and desorbs NO_x when an oxygen concentration in the inflow exhaust gas decreases, and reduces it to N₂. Note that the exhaust air/fuel ratio implies a ratio of a total of the air supplied to the exhaust passageway, an engine combustion chamber and the intake passageway which are disposed upstream of the NO_x catalyst **31** to a total of the fuel (hydro carbon). Accordingly, if the fuel and a reducing agent or the air are not supplied into the exhaust passageway disposed upstream of the NO_x catalyst **31**, the exhaust air/fuel ratio coincides with an air/fuel ratio of an air-fuel mixture supplied into the engine combustion chamber.

In accordance with the first embodiment, what is used as an internal combustion engine is so-called lean-burn gasoline engine capable of burning at the lean air/fuel ratio, and the air/fuel ratio of the air-fuel mixture is controlled corresponding to an operation state of the engine **1**. Therefore, when the engine **1** is operated at the lean air/fuel ratio, the exhaust air/fuel ratio becomes lean, and the oxygen concentration increases. On the other hand, when the engine **1** is operated at a stoichiometric ratio or a rich air/fuel ratio, the exhaust air/fuel ratio comes to the stoichiometric ratio or the rich air/fuel ratio, and the oxygen concentration in the exhaust gas remarkably decreases, with the result that components such as unburned HC and CO discharged from the engine **1** augment.

It is assumed that the NO_x catalyst **31** absorbs and desorbs NO_x by a mechanism as illustrated in FIG. **3**, though this mechanism of NO_x absorbing/desorbing action is partly unclear. This mechanism will be discussed by exemplifying a case where platinum Pt and barium Ba are borne on the carrier, however, the same mechanism might be attained by use of other precious metals, alkali metals, alkaline earth elements and rare earth elements.

To start with, when the inflow exhaust gas exhibits a considerably lean A/F ratio, the oxygen concentration in the inflow exhaust gas remarkably increases, and hence, as shown in FIG. **3(A)**, oxygen O₂ is adhered in the form of O₂⁻ or O²⁻ to the surface of platinum Pt. Next, NO contained in the exhaust gas reacts to O₂⁻ or O²⁻ on the surface of platinum Pt, thereby turning out to be NO₂ (2NO+O₂→2NO₂).

Thereafter, as far as a NO_x absorbing capability of the NO_x catalyst **31** is not saturated, NO₂ which has thus been generated is absorbed within the NO_x catalyst **31** while being oxidized on platinum Pt, then coupled to barium oxide BaO, and diffused in the form of sodium ion NO₃⁻ as shown in FIG. **3(A)**. Thus, NO_x is absorbed within the NO_x catalyst **31**.

By contrast, when the oxygen concentration in the inflow exhaust gas decreases, a generation quantity of NO₂ decreases, and, with reversal reaction (NO₃⁻→NO₂) to the

above reaction, sodium ion NO₃⁻ in the NO_x catalyst **31** is desorbed in the form of NO₂ or NO from the NO_x catalyst **31**.

While on the other hand, if there exist a reducing component such as HC, CO etc in the inflow exhaust gas, these components react to oxygen O₂⁻ or O²⁻ on platinum Pt and thereby oxidized enough to dissipate the oxygen in the exhaust gas, whereby the oxygen concentration in the exhaust gas decreases. Further, NO₂ or NO desorbed from the NO_x catalyst **31** with the decrease in the oxygen concentration in the exhaust gas, reacts to HC, CO and thereby reduced as shown in FIG. **3(B)**. When NO₂ or NO on platinum Pt thus disappears, NO₂ or NO is successively desorbed from the NO_x catalyst **31**.

Namely, HC, Co in the inflow exhaust gas immediately react at first to oxygen O₂⁻ or O²⁻ on platinum Pt and thus oxidized, and subsequently, if HC, Co are still left even when oxygen O₂⁻ or O²⁻ on platinum Pt is dissipated, NO_x desorbed from the NO_x catalyst **31** and NO_x discharged from the engine are reduced to NO₂ with such HC and CO.

As described above, when the exhaust air/fuel ratio becomes lean, the NO_x is absorbed to the NO_x catalyst **31**. When the exhaust air/fuel ratio becomes stoichiometric or rich, the NO_x is desorbed from the NO_x catalyst **31** in a short period of time and reduced to NO₂. It is therefore feasible to hinder NO_x from being discharged into the atmospheric air.

Given next is an explanation of an SO_x poisoning mechanism in the NO_x catalyst **31**. When sulfur oxide (SO_x) is contained in the exhaust gas, the NO_x catalyst **31** absorbs SO_x in the exhaust gas by the same mechanism as the NO_x absorbing mechanism. Namely, when the exhaust air/fuel ratio is lean, oxygen O₂ is adhered in the form of O₂⁻ or O²⁻ to the surface of platinum Pt of the NO_x catalyst **31**, and SO_x (e.g., SO₂) in the inflow exhaust gas is oxidized on the surface of platinum Pt and thereby turned out to be SO₃.

Thereafter, SO₂ which has been generated is absorbed within the NO_x catalyst **31** while being oxidized on the surface of platinum Pt, then coupled to barium oxide BaO, and diffused in the form of sulphate ion SO₄²⁻ thereby forming sulfate BaSO₄. Crystal of sulfate BaSO₄ is easy to roughen and comparatively easy to stabilize. Once the sulfate is produced, it is difficult to dissolve and desorb it. Hence, if a generation quantity of BaSO₄ in the NO_x catalyst **31** increases with an elapse of time, a quantity of BaO capable of getting involved in the absorption of the NO_x catalyst **31** decreases, resulting in a decline of NO_x absorbing capability. Namely, this is what is called the SO_x poisoning. Accordingly, it is required for keeping high the NO_x absorbing capability of the NO_x catalyst **31** that SO_x absorbed to the NO_x catalyst **31** be desorbed at a proper timing.

It has proved that the oxygen concentration of the exhaust gas may be reduced as in the case of desorbing the NO_x in order to desorb the SO_x from the NO_x catalyst **31**. Further, it has also proved that the desorption thereof is easier as a temperature of the NO_x catalyst **31** becomes higher.

It has proved from the study of the present applicant that the desorption of SO_x absorbed to the NO_x catalyst **31** requires setting the inflow exhaust gas air/fuel ratio to the stoichiometric ratio or the rich air/fuel ratio and also making the temperature of the NO_x catalyst **31** higher than in a normal NO_x desorbing/reducing process of desorbing NO_x from the NO_x catalyst **31**.

Furthermore, as for an SO_x absorbing state in the catalytic converter **30**, the NO_x catalyst **31** positioned closer to the inlet **30a** of the catalytic converter **30** absorbs a larger amount of SO_x than the NO_x catalyst **31** positioned farther

away from the inlet **30**. Therefore, when SO_x is desorbed from the NO_x catalyst **31**, SO_x can be desorbed in a short time by setting the exhaust air/fuel ratio to the stoichiometric ratio or the rich air/fuel ratio and by flowing the high-temperature exhaust gas toward the inlet **30a** from the outlet **30b** of the catalytic converter **30**.

Such being the case, in the first embodiment, the of the exhaust gas in the catalytic converter is so controlled as to be switched over by operating the emission switching valve **20**, thus setting in the forward flow the flow of the exhaust gas in the catalytic converter **30** when absorbing NO_x and SO_x and setting in the backward flow the flow of the exhaust gas in the catalytic converter when desorbing NO_x and SO_x .

Next, an operation of the exhaust emission control system in the first embodiment will be described. As explained above, the engine **1** is classified as the lean-burn engine, and the ECU **100** controls the air/fuel ratio in accordance with the operation state of the engine **1**. When the engine **1** is operated at the lean air/fuel ratio, the exhaust air/fuel ratio becomes lean, and the oxygen concentration increases. When the engine **1** is operated at the stoichiometric ratio or the rich air/fuel ratio, the exhaust air/fuel ratio becomes stoichiometric or rich, and the oxygen concentration in the exhaust gas largely decreases. Further, the components of unburned HC and CO discharged from the engine **1** augment.

Then, when the engine **1** is operated at the lean air/fuel ratio, the ECU **100** controls the operation of the actuator **21** so that the valve member of the emission switching valve **20** is kept in the forward flow position shown in FIG. **1**. Under this control, the exhaust gas of the engine **1** flows in the sequence such as the exhaust pipe **9**→the exhaust pipe **11**→the catalytic converter **30**→the exhaust pipe **12**→the exhaust pipe **10**, and is released into the atmospheric air. In the catalytic converter **30**. The exhaust gas flows along the forward flow from the inlet **30a** toward the outlet **30b**. At this time, NO_x catalyst **31** of the catalytic converter **30** absorbs NO_x and SO_x contained in the exhaust gas.

Then, when the engine **1** is operated at the stoichiometric ratio or the rich air/fuel ratio, the ECU **100** controls the operation of the actuator **21** so that the valve member of the emission switching valve **20** is kept in the backward flow position shown in FIG. **2**. Under this control, the exhaust gas of the engine **1** flows in the sequence such as the exhaust pipe **9**→the exhaust pipe **12**→the catalytic converter **30**→the exhaust pipe **11**→the exhaust pipe **10**, and is released into the atmospheric air. In the catalytic converter **30**, the exhaust gas flows along the backward flow from the outlet **30b** toward the inlet **30a**. Further, when the engine **1** is operated at the stoichiometric ratio or the rich air/fuel ratio, the ECU **100** controls the operation of the engine **1** so that the exhaust gas temperature comes to such a temperature as to facilitate desorbing SO_x out of the NO_x catalyst **31**.

The high-temperature exhaust gas exhibiting the stoichiometric ratio or the rich air/fuel ratio flows through within the catalytic converter **30** in the direction opposite to the one when absorbing NO_x and SO_x , whereby NO_x is desorbed from the NO_x catalyst **31**. Further, the exhaust gas is purified by its being reduced to N_2 with unburned HC and CO contained in the exhaust gas. Moreover, the exhaust gas flows back through the catalytic converter **30**, whereby SO_x absorbed to the NO_x catalyst **31** can be desorbed out of the NO_x catalyst **31** in a short time.

Further, if the lean air/fuel ratio operation continues for a long period of time under the operating condition of the engine **1**, the engine **1** is so controlled as to be operated

forcibly at the stoichiometric ratio or the rich air/fuel ratio, and, as described above, there is executed the process of desorbing NO_x and SO_x , whereby the catalytic converter **30** is not saturated with NO_x and SO_x . This air/fuel ratio control method of the engine **1** is referred to as lean/rich spike control in the following discussion. Note that in the case of explaining the lean/rich spike control by specifically exemplifying numerical values thereof, if the “lean air/fuel ratio operation” of the engine **1** continues for several tens of seconds (e.g., 40 to 60 sec), a “stoichiometric ratio or rich air/fuel ratio operation” continues for several seconds (e.g., 2 to 3 sec), this “lean air/fuel ratio operation” and the “stoichiometric ratio or rich air/fuel ratio operation” are alternately executed.

In the first embodiment, the lean-burn gasoline engine constitutes the internal combustion engine, the NO_x catalyst **31** forms an exhaust gas purifying element, and SO_x forms an adhered substance which the exhaust gas purifying element (NO_x catalyst **31**) should be purged of. Furthermore, the control of the operation of the engine **1** serves to obtain the (stoichiometric or rich) air/fuel ratio and the (high) exhaust gas temperature which are needed for purging the exhaust gas purifying element of SO_x , and hence the control of the operation of the engine **1** serves as a purging function in the first embodiment.

In accordance with the first embodiment, a reducing agent adding device for adding the reducing agent is provided at the exhaust passageway (i.e., the exhaust passageway **12** or **9**) positioned more upstream than the catalytic converter **30** when the exhaust gas flowing through the catalytic converter **30** is flowed backward. When executing the process of desorbing NO_x and SO_x , the reducing agent adding device adds the reducing agent into the exhaust gas, thereby making it feasible to speed up the release and reduction of NO_x and also the release of SO_x . In this case, in addition to the control of the operation of the engine **1**, the reducing adding device and the operation control thereof perform the purging function.

Incidentally, in the first embodiment, the processes of desorbing NO_x and SO_x from the NO_x catalyst **31** are executed simultaneously, however, a quantity of SO_x contained in the exhaust gas of the engine especially of the gasoline engine is extremely small, and hence there is no necessity for executing the process of desorbing SO_x at the same frequency as the NO_x desorbing process. Then, in the case of carrying out the NO_x desorbing process, when in the operation state of the engine **1** wherein the exhaust gas temperature is comparatively low even in the operation region of the stoichiometric ratio or rich air/fuel ratio, the exhaust gas flows through the catalytic converter **30** along the same forward flow as it flows when absorbing NO_x , thereby desorbing NO_x from the NO_x catalyst **31** and thus reducing it. On the other hand, when in the operation state (such as an acceleration and a high-load operation) of the engine **1** wherein the exhaust gas temperature rises high as well as in the operation region of the stoichiometric ratio or rich air/fuel ratio, i.e., only when the exhaust gas is in a state of exhibiting the stoichiometric ratio or rich air/fuel ratio advantageous for desorbing SO_x as well as being at a high temperature, the valve member of the emission switching valve **20** is switched over to the backward flow position, and the exhaust gas flow through the catalytic converter **30** is set to the backward flow, thus performing the control to execute the SO_x desorbing process.

Further, the ECU judges whether or not the process of desorbing SO_x from the NO_x catalyst **31** is required. When judging that the SO_x desorbing process is not required, the

valve member of the emission switching valve **20** is kept in the forward flow position, and the exhaust gas flow through the catalytic converter **30** is set to the forward flow. When judging that the SO_x desorbing process is required, the valve member of the emission switching valve **20** is switched over to the backward flow position, and the exhaust gas flow through the catalytic converter **30** is set to the backward flow. Besides, the ECU **100** calculates a target air/fuel ratio and a target catalyst temperature that are optimal to the release of SO_x , and further, if the above-mentioned reducing agent adding device is provided, calculates a target reducing agent quantity. The SO_x desorbing process may be executed by controlling the engine **1** and the reducing agent adding device etc to attain those target values. A method of judging whether the SO_x desorbing process is needed or not may be exemplified such as making the ECU **100** integrate an operation time of the engine **1** and judging that the SO_x desorbing process is needed when an integrated value thereof reaches a predetermined time, or making the ECU **100** integrate an amount of SO_x absorbed to the NO_x catalyst **31** and judging that the SO_x desorbing process is needed when an integrated value thereof reaches a predetermined quantity.

Moreover, as discussed above, the ECU **100**, when judging that the SO_x desorbing process is necessary, sets the exhaust gas flow through the catalytic converter **30** in the backward flow by switching over the position of the valve member of the emission switching valve **20**, and sets the operation to the stoichiometric ratio or rich air/fuel ratio operation, thus desorbing SO_x , in which case it is preferable that the air/fuel ratio be lean during the operation of switching over the position of the valve member of the emission switching valve **20**. The following is an elucidation of the reason why so. The emission switching valve **20** is structured such that when switching over the valve member position from the forward flow position to the backward flow position and vice versa, there must be invariably, as shown in FIG. **4**, a state where the exhaust pipe **9** communicates with the exhaust pipe **10** in the middle of the switching operation thereof. Thus, in the state where the exhaust pipe **9** communicates with the exhaust pipe **10**, the exhaust gas flows along a short path from the exhaust pipe **9** to the exhaust pipe **10** in terms of a flow resistance, and there might be a possibility in which HC and CO contained in the exhaust gas are discharged into the atmospheric air. Such being the case, in order to reduce HC and CO to the greatest possible degree which are to be discharged into the atmospheric air during the operation of switching over the position of the valve member of the emission switching valve **20**, the exhaust air/fuel ratio is controlled lean during the operation of switching over the position of the valve member of the emission switching valve **20**.

As discussed above, according to the exhaust emission control system in the first embodiment, it is feasible to switch over the flow direction of the exhaust gas flowing through the catalytic converter **30** to the forward flow or backward flow simply by changing over the position of the valve member of only the single emission switching valve **20**, which structure is simple enough to attain at low costs.

The drawings in FIGS. **5** through **15** are diagrams illustrating modified examples of the first embodiment of the exhaust emission control system of the internal combustion engine. Each of these modified examples will hereinafter be discussed.

<Modified Example Shown in FIG. **5**>

According to the above-described mode illustrated in FIG. **1**, a pipe length of the exhaust pipe **12** for connecting the

emission switching valve **20** to the outlet **30b** of the catalytic converter, is set larger than a pipe length of the exhaust pipe **11** for connecting the emission switching valve **20** to the inlet **30a** of the catalytic converter. In the modified example illustrated in FIG. **5**, however, the pipe length of the exhaust pipe **12** for connecting the emission switching valve **20** to the outlet **30b** of the catalytic converter, is set smaller than the pipe length of the exhaust pipe **11** for connecting the emission switching valve **20** to the inlet **30a** of the catalytic converter.

<Modified Examples Shown in FIGS. **6** and **7**>

Modified examples shown in FIG. **6** and **7** are each slightly different from the example shown in FIG. **1** or **5** in terms of the position in which to dispose the emission switching valve **20**. If the emission switching valve **20** is disposed in a position as shown in FIG. **6** or **7**, the pipe length of the exhaust pipe **9** for connecting the exhaust manifold **8** to the emission switching valve **20**, can be larger than in the example showing in FIG. **1** or **5**.

<Modified Examples Shown in FIGS. **8** to **11**>

Modified examples shown in FIGS. **8** to **11** each exemplify a case where the emission switching valve **20** in the mode illustrated in FIG. **6**, the exhaust pipes **9** to **12** and the catalytic converter **30** are constructed into one unit.

This exhaust gas purifying unit **50A** is constructed as follows. As illustrated in FIG. **10**, a small-diameter **52** concentrically penetrates a large-diameter casing **51** of which both ends are closed, and is fixed therein. An annular space **53** is formed between the casing **51** and the pipe **52**. A NO_x catalyst **31** is disposed approximately in the middle position within the annular space **53** in an axial direction of the casing **51**, and the space **53** is sectioned by the NO_x catalyst **31** into two sub-spaces **54**, **55**.

A flange **52a** provided at one end of the pipe **52** protruding from the casing **51** is connected to the exhaust pipe **9** communicating with the exhaust manifold **8**. A flange **52b** provided at the other end of the pipe **52** protruding from the casing **51** is connected to the exhaust pipe **10** open to the atmospheric air.

At portions, contiguous to one sub-space **55**, of the pipe **52**, a pair of openings **56**, **57** are formed in face-to-face positions with the pipe **52** axial center being at the middle therebetween. One opening **56** is open to one end of a connection pipe **58**, and the other end of this connection pipe **58** penetrates the sub-space **55** and the casing **51**, and communicates with the other sub-space **54** along the external portion of the casing **51**. Further, a valve member **59** is rotatably disposed at a space formed with the openings **56**, **57** in the interior of the pipe **52**. The valve member **59** is rotated by an actuator **21**.

As shown in FIG. **11**, the valve member **59** can be held in two closing position for closing the pipe **52**. When the valve member **59** is held in the first closing position indicated by the solid line in FIG. **11**, a portion of the pipe **52**, which is closer to the flange **52a** than the valve member **59**, is connected via the opening **56** to the connection pipe **58**. A portion of the pipe **52**, which is closer to the flange **52b** than the valve member **59**, is connected via the opening **57** to the sub-space **55**. In contrast with this, when the valve member **59** is held in the second closing position indicated by the two-dotted line in FIG. **11**, the portion of the pipe **52**, which is closer to the flange **52a** than the valve member **59**, is connected via the opening **57** to the sub-space **55**. The portion of the pipe **52**, which is closer to the flange **52b** than the valve member **59**, is connected via the opening **56** to the connection pipe **58**.

The thus constructed exhaust gas purifying unit 50A has a corresponding relationship with what is constructed in the mode shown in FIG. 6, which is given as below. A valve member 59 of the exhaust gas purifying unit 50A corresponds to the valve member of the emission switching valve 20 in the mode shown in FIG. 6. A portion of the pipe 52 of the exhaust gas purifying unit 50A, which is more proximal to the flange 52a than the valve member 59, corresponds to a part of the exhaust pipe 9 in the mode illustrated in FIG. 6. A portion, which is more proximal to the flange 52b than the valve member 59, corresponds to a part of the exhaust pipe 10 in the mode illustrated in FIG. 6. The sub-space 54 and the connection pipe 58 of the exhaust gas purifying unit 50A correspond to the exhaust pipe 11 in the mode shown in FIG. 6, and the sub-space 55 of the exhaust gas purifying unit 50A corresponds to the exhaust pipe 12 in the mode illustrated in FIG. 6.

FIGS. 8 and 9 are sectional views each showing the exhaust gas purifying unit 50A, wherein the bracketed numerals indicate components corresponding to those in FIG. 6. FIG. 8 illustrates a state where the exhaust gas flows through the NO_x catalyst 31 along the forward flow. FIG. 9 illustrates a state where the exhaust gas flows through the NO_x catalyst 31 along the backward flow. Note that in the case of being constructed as exemplified in this exhaust gas purifying unit 50A, its operation as an exhaust emission control system is the same as that in the first embodiment, of which the explanation is therefore omitted.

<Modified Examples Shown in FIGS. 12 through 15>Modified examples shown in FIGS. 12 to 15 each shows a case where the control system is structured in a more compact configuration by eliminating the connection pipe 58 from the exhaust gas purifying unit 50A illustrated in FIGS. 8 through 11. Differences from the mode illustrated in FIGS. 8 to 11 are explained hereinafter, and the same components are marked with the same numerals with an omission of their explanation.

In an exhaust gas purifying unit 50B in this modified example, an annular space formed between the casing 51 and the pipe 52 is sectioned into three spatial areas, i.e., an annular sub-space 60 formed at an end portion on the side of the flange 52a, and sub-spaces 62, 63 each taking a sectionally semicircular shape which are vertically divided into two spatial areas by a partition plate 61 extending from the casing 51 to the pipe 52 and fixed thereto.

Then, referring to FIG. 14, the NO_x catalyst 31 is disposed, in close proximity to the sub-space 60, within the semicircular sub-space 63 positioned upward. The sub-space 64 is formed in an area closer to the flange 52b than the NO_x catalyst 31 within the subspace 63, and the opening 57 of the pipe 52 communicates with the sub-space 64. On the other hand, referring again to FIG. 14, the semicircular sub-space 62 positioned downward communicates with the annular sub-space 60 and with the opening 56 of the pipe 52.

A positional relationship between the valve member 59 and the openings 56, 57, and two closing positions of the valve member 59 for closing the pipe 52, are absolutely the same as those in the exhaust gas purifying unit 50A illustrated in FIGS. 8 to 11. Then, explaining the case of the exhaust gas purifying unit 50B in the present modified example with reference to FIG. 11, when the valve member 59 is held in the first closing position indicated by the solid line in FIG. 11, the portion of the pipe 52, which is closer to the flange 52a than the valve member 59, is connected via the opening 56 to the downward semicircular sub-space 62. The portion of the pipe 52, which is closer to the flange 52b

than the valve member 59, is connected via the opening 57 to the sub-space 64. In contrast with this, when the valve member 59 is held in the second closing position indicated by the two-dotted line in FIG. 11, the portion of the pipe 52, which is closer to the flange 52a than the valve member 59, is connected via the opening 57 to the sub-space 64. The portion of the pipe 52, which is closer to the flange 52b than the valve member 59, is connected via the opening 56 to the downward semicircular sub-space 62.

The thus constructed exhaust gas purifying unit 50B has a corresponding relationship with what is constructed in the mode shown in FIG. 6, which is given as below. A valve member 59 of the exhaust gas purifying unit 50B corresponds to the valve member of the emission switching valve 20 in the mode shown in FIG. 6. The portion of the pipe 52 of the exhaust gas purifying unit 50B, which is more proximal to the flange 52a than the valve member 59, corresponds to a part of the exhaust pipe 9 in the mode illustrated in FIG. 6. The portion, which is more proximal to the flange 52b than the valve member 59, corresponds to a part of the exhaust pipe 10 in the mode illustrated in FIG. 6. The downward semicircular sub-space 62 and the annular sub-space 60 of the exhaust gas purifying unit 50B correspond to the exhaust pipe 11 in the mode shown in FIG. 6, and the sub-space 64 of the exhaust gas purifying unit 50B corresponds to the exhaust pipe 12 in the mode illustrated in FIG. 6.

FIGS. 12 and 13 are sectional views each showing the exhaust gas purifying unit 50B, wherein the bracketed numerals indicate components corresponding to those in FIG. 6. FIG. 12 illustrates a state where the exhaust gas flows through the NO_x catalyst 31 along the forward flow. FIG. 13 illustrates a state where the exhaust gas flows through the NO_x catalyst 31 along the backward flow. Note that in the case of being constructed as exemplified in this exhaust gas purifying unit 50b, its operation as an exhaust emission control system is the same as that in the first embodiment, of which the explanation is therefore omitted.

Second Embodiment

Next, a second embodiment of the exhaust emission control system of the internal combustion engine according to the present invention, will be described with reference to FIG. 16. FIG. 16 is a view of the principal components of the exhaust emission control system in the second embodiment, showing a state where the valve member of the exhaust switching member 20 is located in the forward flow position. A difference of the second embodiment from the first embodiment is only such a point that a sweeper 40 is provided midway of the exhaust pipe 10. The sweeper 40 is stored inside with a catalyst (e.g., a selective reduction type NO_x catalyst for reducing or dissolving NO_x under an existence of hydro carbon in an over-oxygen atmosphere) 40a for adsorbing oxygen when the air/fuel ratio of the exhaust gas is lean, and purging the exhaust gas of HC and CO with the oxygen adsorbed thereto when the air/fuel ratio of the exhaust gas is stoichiometric or rich.

As discussed above, the emission switching valve 20 presents a state where the exhaust pipe 9 is invariably connected to the exhaust pipe 10 in the middle of the operation of switching over the position of the valve member thereof, during which the exhaust gas takes a short path from the exhaust pipe 9 to the exhaust pipe 10, and there might be such a possibility that HC and CO contained in the exhaust gas are discharged into the atmospheric air. It is required that this be given an attention in the case of the operation of switching over the position of the valve member

of the emission switching valve 20 when the air/fuel ratio of the exhaust gas is stoichiometric or rich. A contrivance coping with this is just the sweeper 40 provided in the second embodiment.

With the sweeper 40 installed at the exhaust pipe 10, the catalyst 40a of the sweeper 40 adsorbs the oxygen when the engine 1 is operated at the lean air/fuel ratio. Then, the engine 1 comes into the stoichiometric ratio or rich air/fuel ratio operation, and the position of the valve member of the emission switching valve 20 is thereby switched over. For the duration of this switching operation, the exhaust gas exhibiting the stoichiometric ratio or rich air/fuel ratio takes the short path to the exhaust pipe 10, at which time HC and CO contained in the exhaust gas are oxidized by the oxygen adsorbed to the catalyst 40a of the sweeper 40, and the exhaust gas is thus purged of HC and CO and discharged into the atmospheric air.

FIGS. 17 [and] to 19 are diagrams each showing a modified example of the second embodiment of the exhaust emission control system. The respective modified examples will hereinafter be explained.

<Modified Example Shown in FIG. 17>

As shown in FIG. 17, the catalytic converter 30 is integrated with the sweeper 40 so that the exhaust gas is unable to flow between the converter 30 and the sweeper 40 but the heat can be transmitted therebetween. With this construction, a temperature of the catalyst 40a of the sweeper 40 can be kept as high as possible, which is advantageous in terms of activating the catalyst 40a of the sweeper 40. Incidentally, FIG. 17 shows a state where the valve member of the emission switching valve 20 is located in the forward flow position.

<Modified Example Shown in FIG. 18>

FIG. 18 shows an example of disposing the catalytic converter 30 with its outlet 30b positioned to be close to the exhaust switching valve 20, in order that the length of the exhaust pipe 12 connecting the exhaust switching valve 20 with the outlet 30b of the catalytic converter 30 is made as short as possible. With this arrangement, when the exhaust gas is flowed backward towards the catalytic converter 30 by switching over the valve body of the exhaust switching 20- to the backward flow position, as shown in FIG. 18, the exhaust flow length from the engine 1 to the catalytic converter 30 can be made shorter, thereby a increase of the temperature of the NO_x catalyst 31 of the catalytic converter 30 can be promoted at the time of the SO_x releasing process, and the catalytic temperature can also be raised, thereby the release of SO_x is prompted.

<Modified Example Shown in FIG. 19>

FIG. 19 shows an example in which the emission switching valve 20 is disposed in close proximity to the sweeper 40 so as to elongate the flow path extending from the engine 1 to the emission switching valve 20 for the purpose of relieving a thermal load upon the emission switching valve 20. This has an advantage in terms of a durability of the emission switching valve 20. Note that FIG. 19 illustrates a state in which the valve member of the emission switching valve 20 is located in the forward flow position.

Third Embodiment

Next, a third embodiment of the exhaust emission control system of the internal combustion engine according to the present invention will be discussed referring to FIG. 2. FIG. 20 is a diagram showing the principal components of the exhaust emission control system in the third embodiment. A

difference of the third embodiment from the second embodiment illustrated in FIG. 16 is a NO_x catalyst 31 accommodated in the catalytic converter 30.

To describe it more specifically, a NO_x catalyst 31a having high SO_x absorbing power is accommodated on the side of the inlet 30a of the catalytic converter 30, and a NO_x catalyst 31b having comparatively low SO_x absorbing power is accommodated on the side of the outlet 30b thereof. With this arrangement, when the exhaust gas flows through the catalytic converter 30 along the forward flow as shown in FIG. 20, SO_x in the exhaust gas is absorbed only on the side of the inlet 30a of the catalytic converter 30 and is desorbed at a high efficiency when executing the SO_x desorbing process in which the exhaust gas flows backward through the catalytic converter 30.

Note that what can be exemplified as a method of providing the NO_x catalyst 31a having the high SO_x absorbing power on the side of the inlet 30a of the catalytic converter 30 and the NO_x catalyst 31b having the comparatively low SO_x absorbing power on the side of the outlet 30b thereof, may be a method of bearing a larger amount of occlusion substance on the side of the inlet 30a than on the side of the outlet 30b, or bearing the occlusion substance having stronger occluding power on the side of the inlet 30a than on the side of the outlet 30b.

FIG. 21 is a diagram showing a modified example of the third embodiment of the exhaust emission control system. In this modified example, an electric heater 33 for heating the NO_x catalyst 31a exhibiting the high SO_x absorbing power, is attached to an outer peripheral portion of the catalytic converter 30 on the inlet 30a side. As shown in FIG. 21, when the exhaust gas flows backward through the catalytic converter 30 to desorb SO_x out of the NO_x catalyst 31a, the ECU 100 performs control to switch ON the electric heater 33. When in the SO_x desorbing process, the heater 33 forcibly heats up the NO_x catalyst 31a to increase a catalyst temperature, thereby speeding up the desorption of SO_x. It is to be noted that the element for heating up the NO_x catalyst 31a is not limited to the electric heater.

Fourth Embodiment

Next, a fourth embodiment of the exhaust emission control system of the internal combustion engine according to the present invention will be discussed with reference to FIGS. 22 and 23. FIG. 22 is a diagram showing the principal components of the exhaust emission control system in the fourth embodiment. A difference of the fourth embodiment from the second embodiment illustrated in FIG. 16 is only such a point that a start catalyst (another catalyst) unit 41 is provided midway of the exhaust pipe 9.

The start catalyst unit 41 is stored inside with a catalyst 41a such as a three-way catalyst having a high activation.

Generally, the start catalyst unit is installed for raising the catalyst temperature as well as for speeding up the rise in the temperature of the posterior catalyst (which is the NO_x catalyst 31 (of the catalytic converter 30 in the fourth embodiment) when starting up the engine. In the fourth embodiment, in addition to this operation, when the exhaust gas flows along the forward flow through the catalytic converter 30 as shown in FIG. 22, the reducing component in the exhaust gas is dissipated in the start catalyst unit 41, and therefore the reductive gas component in the exhaust gas flowing into the catalytic converter 30, is decreased. As a result, NO_x and SO_x are absorbed higher on the side of the inlet 30a to the NO_x catalyst 31 of the catalytic converter 30. This facilitates the desorption of NO_x and SO_x from the NO_x

catalyst **31** when the exhaust gas flows backward through the catalytic converter **30**.

Incidentally, it is preferable that the start catalyst unit be provided in a location (i.e., a position in which to take a short distance of the flow path from the engine **1**) closer to the intake manifold.

Further, when installing the start catalyst unit **41**, the SO_x desorbing process from the NO_x catalyst **31** of the catalytic converter **30** is executed by flowing through the catalytic converter **30** the exhaust gas having the stoichiometric ratio or rich air/fuel ratio. Thereupon, at an early stage of the SO_x desorbing process, SO_x is desorbed also from the catalyst **41a** of the start catalyst unit **41**. It is not preferable that the SO_x desorbed out of the start catalyst unit **41** flows to the catalytic converter **30**. Such being the case, in accordance with the fourth embodiment, when switching over the position of the valve member of the emission switching valve **20** in order to execute the SO_x desorbing process, what should be done is not that the valve member of the emission switching valve **20** is immediately switched over from the forward flow position to the backward flow position, but that the ECU **100** controls the actuator **21** in order to let the exhaust gas take a short path from the exhaust pipe **9** to the exhaust pipe **10** by holding the valve member of the emission switching valve **20** in a neutral position as shown in FIG. **23** for a predetermined time since the exhaust gas exhibiting the stoichiometric ratio or rich air/fuel ratio started flowing to the start catalyst unit **41**. Herein, if the predetermined time is set to a time enough to complete the desorption of SO_x from the catalyst **41a** for the start catalyst unit **41**, it is feasible to hinder the inflow, into the catalytic converter **30**, of SO_x desorbed from the start catalyst unit **41**. Meanwhile, the exhaust gas containing SO_x desorbed from the start unit **41** is purified by the sweeper **40**. Then, after the predetermined time has elapsed, the valve member of the emission switching valve **20** is switched over to the backward flow position.

Fifth Embodiment

Next, a fifth embodiment of the exhaust emission control system of the internal combustion engine according to the present invention will be discussed with reference to FIG. **24**. FIG. **24** is a diagram showing the principal components of the exhaust emission control system in the fifth embodiment. A difference of the fifth embodiment from the modified example of the second embodiment which is illustrated in FIG. **18** is only such a point that an S-trap **42** is provided midway of the exhaust pipe **11**.

The S-trap **42** is stored inside with an SO_x absorbing agent **42a**. The SO_x absorbing agent **42a** absorbs SO_x when the air/fuel ratio of the inflow gas is lean, and, when a concentration of the oxygen of the inflow gas is low, desorbs SO_x absorbed. What can be exemplified as the SO_x absorbing agent **42a** may be the three-way catalyst, the NO_x catalyst exhibiting the high SO_x absorbing power among the NO_x storage-reduction catalyst, and also an agent of zeolite borne with platinum.

If the S-trap **42** is thus provided, as shown in FIG. **24**, the S-trap **42** is disposed more upstream than the catalytic converter **30** when the valve member of the emission switching valve **20** is set in the forward flow position (i.e., when absorbing NO_x). Therefore, SO_x contained in the exhaust gas is adsorbed to the SO_x absorbing agent **42a** in the S-trap **42**, and can be thereby hindered from flowing into the catalytic converter **30**, whereby the NO_x catalyst **31** of the catalytic converter **30** can be prevented from the SO_x poisoning. In the fifth embodiment, the SO_x absorbing agent **42a** in the S-trap **42** constitutes an exhaust gas purifying element.

In the fifth embodiment also, the exhaust gas can be flowed back to the S-trap **42** by switching over the valve member of the emission switching valve **20** to the backward flow position. At this time, the exhaust gas, of which the air/fuel ratio is stoichiometric or rich, is flowed, thereby making it possible to desorb SO_x from the SO_x absorbing agent **42a** in the S-trap **42** and discharge it in the form of SO_2 . Further, on this occasion, the ECU **100** calculates a target air/fuel ratio of the exhaust gas flowing into the S-trap **42**, a target floor temperature of the S-trap **42** and, if the reducing agent adding device is provided, a target reducing agent quantity, which are optimal to the SO_x desorption from the SO_x absorbing agent in the S-trap **42**. Then, ECU **100** controls the engine **1** and the reducing agent adding device etc to attain those target values, and it is preferable that the SO_x desorbing process be thus executed.

Further, for increasing the floor temperature under the control of the floor temperature of the S-trap **42**, it is also feasible to raise a temperature of the S-trap **42** by increasing the concentration of the oxygen in the exhaust gas flowing into the catalytic converter **30** and by raising an exhaust gas temperature with a heat emission due to oxidation through the NO_x catalyst **31** of the catalytic converter **30**.

FIG. **25** is a diagram showing a modified example of the above-described fifth embodiment of the exhaust emission control system. The catalytic converter **30**, the sweeper **40** and the S-trap **42** are integrated into one unit so that the exhaust gas is not permitted to flow to each other but the heat can be transmitted to each other. With this configuration, the reaction heat in the catalyst can be effectively utilized, which is advantageous to every catalyst in terms of the activation. Incidentally, FIG. **25** shows a state where the valve member of the emission switching valve **20** is located in the forward flow position.

Note that a timing at which to switch over the position of the valve member of the emission switching valve **20** or of the valve member **59**, i.e., a timing of switching over the exhaust gas flowing through the exhaust gas purifying element to the forward flow and the backward flow, is not limited to the timings explained in the first through fifth embodiments discussed above.

[Fir] For example, if the exhaust gas purifying element is defined as the NO_x catalyst **31**, the NO_x catalyst **31** has a property of easily absorbing SO_x and SO_x when the exhaust gas temperature lowers and desorbing them when the exhaust gas temperature rises. Hence, the emission switching valve **20** or the valve member **59** may be so controlled as to be switched over so that when the exhaust gas temperature lowers, the position of the valve member of the emission switching valve **20** or of the valve member **59** is set to the forward flow position, and the exhaust gas flows along the forward flow through the NO_x catalyst **31**, and so that when the exhaust gas temperature rises, the position of the valve member of the emission switching valve **20** or of the valve member **59** is set to the backward flow position, and the exhaust gas flows along the backward flow through the NO_x catalyst **31**.

Moreover, depending on a deposit of which the exhaust gas purifying element should be purged of, the deposit to be eliminated is dissolved and desorbed as in the case of H_2SO_4 when the floor temperature of the exhaust gas purifying element becomes a predetermined temperature (e.g., 40°C .) or over, in which case when the floor temperature is lower than the predetermined temperature, the position of the valve member of the emission switching valve **20** or of the valve member **59** is set to the forward flow position, whereby the

exhaust gas flows along the forward flow through the purifying element. When the floor temperature is over the predetermined temperature, the position of the valve member of the emission switching valve **20** or of the valve member **59** is switched over to the backward flow position, whereby the exhaust gas flows along the backward flow through the purifying element. The position of the valve member of the emission switching valve **20** or of the valve member **59** may be so controlled as to be switched over in this manner.

Sixth Embodiment

Next, a sixth embodiment of the exhaust emission control system of the internal combustion engine according to the present invention will be discussed with reference to FIGS. **26** and **28**.

In the first through fifth embodiments discussed above, when the exhaust gas flows through the catalytic converter **30** or the S-trap **42**, SO_x contained in the exhaust gas is absorbed to the area close to the exhaust gas flow inlet of the catalytic converter **30** or the S-trap **42**. Therefore, in the case of desorbing SO_x from the catalytic converter **30** or the S-trap **42**, when the exhaust gas exhibiting the stoichiometric ratio or rich air/fuel ratio in the opposite direction than in the direction when executing the absorbing process, SO_x desorbed from the NO_x catalyst **31** or from the SO_x absorbing agent **42a** can be discharged at a shorter distance from the catalytic converter **30** or the S-trap **42**, and the SO_x desorbing process can be executed at a higher efficiency. Based on this notion, the position of the valve member of the emission switching valve is so controlled as to be switched over.

By contrast, according to the sixth embodiment, when switching over the position of the valve member of the emission switching valve **20**, there might change a length of the flow path till the exhaust gas flows into the catalytic converter **30**. Giving attention to this point, a position of a valve member of an emission switching valve **30** is so controlled as to be switched over in relation to a temperature characteristic of the NO_x catalyst **31**.

FIG. **26** is a diagram schematically illustrating a construction of the exhaust emission control system in the sixth embodiment. The construction of this control system is, however, absolutely the same as that of the exhaust emission control system in the first embodiment shown in FIG. **1**, of which the explanation is therefore omitted, and the operation in the sixth embodiment will hereinafter be described. Note that the NO_x catalyst **31** constitutes an exhaust gas purifying element also in the sixth embodiment.

FIG. **26** shows a state when the valve member of the emission switching valve **20** is located in the forward flow position. FIG. **27** shows a state when the valve member of the emission switching valve **20** is located in the backward flow position. It can be understood from FIGS. **26** and **27** that the length of the flow path till the exhaust gas flows into the catalytic converter **30** is smaller when the valve member of the emission switching valve **20** is located in the forward flow position than when located in the backward flow position.

Now, upon an inflow of the exhaust gas through the exhaust pipe, the temperature of the exhaust gas decreases due to a radiating phenomenon, and the decrease in the temperature becomes larger as the length of the flow path increases. Accordingly, the decrease in the exhaust gas temperature is larger till the exhaust gas flows into the catalytic converter **30** when the valve member of the emission switching valve **20** is located in the backward flow position than when located in the forward flow position.

On the other hand, as shown in FIG. **28**, a NO_x purging rate of the NO_x catalyst **31** is correlated to a temperature of the catalyst, and has a temperature window optimal to the NO_x absorption (which is hereinafter be termed a NO_x absorbing window). When deviating from this NO_x absorbing window, the NO_x absorbing power largely declines. Further, when desorbing and reducing NO_x from the NO_x catalyst **31**, NO_x can be desorbed even if the temperature of the NO_x catalyst **31** is not set so high. When desorbing SO_x from the NO_x catalyst **31**, however, as explained above, SO_x can be desorbed at the higher efficiency by setting high the temperature of the NO_x catalyst **31**.

Then, according to the exhaust emission control system in the sixth embodiment, the switch-over of the position of the valve member of the emission switching valve is controlled in the way that follows.

To begin with, when there is a condition under which NO_x can be absorbed to the NO_x catalyst **31**, i.e., when the temperature of the NO_x catalyst **31** is low (e.g., lower than 400°C .) and the air/fuel ratio of the exhaust gas is lean (i.e., when the engine **1** is operated at the lean air/fuel ratio), the valve member of the emission switching valve **20** is located in the forward flow position. With this setting, it is possible to decrease the length of the flow path till the exhaust gas flows into the catalytic converter **30**, and there is diminished the decrease in the temperature of the exhaust gas till the exhaust gas flows into the catalytic converter **30**. It is therefore feasible to restrain the drop in the temperature of the NO_x catalyst **31** and to keep the NO_x catalyst **31** at a temperature suited to the NO_x absorption.

Next, when there is a condition under which NO_x absorbed to the NO_x catalyst **31** can be desorbed and reduced, i.e., when the temperature of the NO_x catalyst **31** is low (e.g., 400°C . or lower) and the air/fuel ratio of the exhaust gas is stoichiometric or rich (i.e., when the engine **1** is operated at the stoichiometric ratio or rich air/fuel ratio), the valve member of the emission switching valve **20** is located in the forward flow position. With this setting, it is possible to decrease the length of the flow path till the exhaust gas flows into the catalytic converter **30**, and there is diminished the decrease in the temperature of the exhaust gas till the exhaust gas flows into the catalytic converter **30**. It is therefore feasible to restrain the drop in the temperature of the NO_x catalyst **31** and to keep the NO_x catalyst **31** at a temperature suited to the NO_x desorption and reduction.

Further, when the temperature of the NO_x catalyst **31** is high (e.g., 400°C . or higher) enough to deteriorate the NO_x purging rate (i.e., when the engine **1** is operated at the lean air/fuel ratio), the valve member of the emission switching valve **20** is located in the backward flow position. With this setting, it is possible to increase the length of the flow path till the exhaust gas flows into the catalytic converter **30** and to thereby speed up the decrease in the temperature of the NO_x catalyst **31**. As a result, the NO_x catalyst **31** can be kept at a temperature suited to the NO_x absorption.

Moreover, when there is a condition under which SO_x absorbed to the NO_x catalyst **31** can be desorbed, i.e., when the temperature of the NO_x catalyst **31** is high (e.g., 600°C . or higher) and the air/fuel ratio of the exhaust gas is stoichiometric or rich (i.e., when the engine **1** is operated at the stoichiometric ratio or rich air/fuel ratio), the valve member of the emission switching valve **20** is located in the forward flow position. With this setting, it is possible to decrease the length of the flow path till the exhaust gas flows into the catalytic converter **30**, and there is diminished the decrease in the temperature of the exhaust gas till the exhaust gas

29

flows into the catalytic converter **30**. It is therefore feasible to restrain the drop in the temperature of the NO_x catalyst **31** and to keep the NO_x catalyst **31** at a temperature suited to the SO_x desorption.

Note that an exhaust gas temperature detected by the exhaust gas temperature sensor **13** provided in the vicinity of the inlet **30a** of the catalytic converter **30** serves as a substitute for the catalytic temperature of the NO_x catalyst **31** in the sixth embodiment.

Seventh Embodiment

Next, a seventh embodiment of the exhaust emission control system of the internal combustion engine according to the present invention will be discussed with reference to FIGS. **29** and **30**. FIG. **29** is a diagram showing the principal components of the exhaust emission control system in the seventh embodiment, wherein the valve member of the emission switching valve **20** is located in the forward flow direction. A difference of the seventh embodiment from the sixth embodiment is only such a point that the sweeper **40** is provided midway of the exhaust pipe **10**. Note that the NO_x catalyst **31** constitutes the exhaust gas purifying element also in the seventh embodiment.

The sweeper **40** is stored inside with a catalyst (e.g., the selective reduction type NO_x catalyst for reducing or dissolving NO_x under the existence of hydro carbon in the over-oxygen atmosphere) **40a** for adsorbing the oxygen when the air/fuel ratio of the exhaust gas is lean, and purging the exhaust gas of HC and CO with the oxygen adsorbed thereto when the air/fuel ratio of the exhaust gas is stoichiometric or rich. Accordingly, in the lean-burn gasoline engine **1** in the seventh embodiment, when the engine **1** is operated at the lean air/fuel ratio, the catalyst **40a** of the sweeper **40** adsorbs the oxygen in the exhaust gas.

In the sixth embodiment discussed above, when the temperature of the NO_x catalyst **31** is high, and when the air/fuel ratio of the exhaust gas is lean, the valve member of the emission switching valve **20** is located in the backward flow position, thereby increasing the length of the flow path till the exhaust gas flows into the catalytic converter **30** and augmenting the drop in the temperature of the exhaust gas. With this contrivance, the temperature of the NO_x catalyst **31** is controlled to fall within the NO_x absorbing window. If done in this way, however, it might be considered that the temperature of the NO_x catalyst **31** exceeds the NO_x absorbing window.

The high-temperature exhaust gas is flowed in the state where the temperature of the NO_x catalyst **31** exceeds the NO_x absorbing window, and the exhaust gas still remains unpurified. On the contrary, it might happen that NO_x catalyst **31** is deteriorated.

This being the case, according to the exhaust emission control system in the seventh embodiment, when the air/fuel ratio of the exhaust gas is lean (i.e., when the engine **1** is operated at the lean air/fuel ratio), and when the temperature of the NO_x catalyst **31** becomes high (e.g., 500° C. or higher) over the NO_x absorbing window, as shown in FIG. **30**, the valve member of the emission switching valve **20** is located in a neutral position between the forward flow position and the backward flow position. With this setting, the exhaust gas takes a short path from the exhaust pipe **9** to the exhaust pipe **10**, and does not substantially flow to the catalytic converter **30**. Then, the exhaust gas containing HC and Co which flows out to the exhaust pipe **10**, is purged of HC and CO with the oxygen adsorbed to the catalyst **40a** of the sweeper **40**, and then discharged into the atmospheric air.

30

Accordingly, the NO_x catalyst **31** stored in the catalytic converter **30** can be prevented from being deteriorated.

Eighth Embodiment

Next, an eighth embodiment of the exhaust emission control system of the internal combustion engine according to the present invention will be discussed with reference to FIG. **31**. FIG. **31** is a diagram of the principal components of the exhaust emission control system in the eighth embodiment, showing a state where the valve member of the emission switching valve **20** is located in the backward flow direction. A difference of the eighth embodiment from the seventh embodiment is only such a point that a cooler (cooling unit) **43** is provided midway of the exhaust pipe **12**.

In the sixth embodiment discussed above, when the temperature of the NO_x catalyst **31** is high, and when the air/fuel ratio of the exhaust gas is lean, the valve member of the emission switching valve **20** is located in the backward flow position, thereby increasing the length of the flow path till the exhaust gas flows into the catalytic converter **30** and augmenting the drop in the temperature of the exhaust gas. With this contrivance, the temperature of the NO_x catalyst **31** is controlled to fall within the NO_x absorbing window. If done in this way, however, it might be considered that the temperature of the NO_x catalyst **31** exceeds the NO_x absorbing window.

Then, according to the eighth embodiment, when the air/fuel ratio of the exhaust gas is lean (i.e., when the engine **1** is operated at the lean air/fuel ratio), and when the temperature of the NO_x catalyst **31** becomes high (e.g., 500° C. or higher) over the NO_x absorbing window, as shown in FIG. **31**, the valve member of the emission switching valve **20** is located in the backward flow position, and the cooler is operated. If thus operated, it is feasible to increase the length of the flow path till the exhaust gas flows into the catalytic converter **30** and to augment the drop in the temperature of the exhaust gas till the exhaust gas flows into the catalytic converter **30**. Besides, the temperature of the exhaust gas can be forcibly lowered by the cooler **43**, and hence the decrease in the temperature of the NO_x catalyst **31** can be speed up. As a consequence, the NO_x catalyst **31** can be kept at a temperature suited to the NO_x absorption.

Note that the cooler **43** may be of either a water cooling type or an air cooling type, and a structure thereof is not particularly limited. In short, the cooler **43** may incorporate a function capable of cooling the temperature of the exhaust gas flowing through the exhaust pipe **12**.

Ninth Embodiment

Next, a ninth embodiment of will be described with reference to FIGS. **32** to **36**.

FIG. **32** is a view schematically illustrating a construction of the exhaust emission control system of the internal combustion engine in the ninth embodiment. The engine **1** is classified as a lean-burn gasoline engine, wherein the intake air is supplied to each of the cylinders via the intake pipe **2** and the intake manifold **3**. The fuel is injected out of the fuel injection valve **7** into each intake passageway communicating with each cylinder. The exhaust gas discharged from each cylinder is exhausted via the exhaust manifold **8** and the exhaust pipe **9**. The intake pipe **2** is provided with the throttle valve **4** including the throttle position sensor **5**, and the air-flow meter **6**. The exhaust pipe **9** is provided with the exhaust gas temperature sensor **13**. The engine speed sensor **14** is provided in the engine **1**. Respective output signals of

31

the throttle position sensor **5**, the airflow meter **6**, the exhaust gas temperature sensor **13** and the engine speed sensor **14**, are outputted to the ECU **100**. The operation of the fuel injection valve **7** is controlled based on the output signals transmitted from the ECU **100**, and this construction is absolutely the same as that in the first embodiment discussed above.

The exhaust emission control system in the ninth embodiment has a different configuration on the downstream side of the exhaust pipe **9** from the configuration in the first embodiment, which will hereinafter be described in details.

A downstream-end of the exhaust pipe **9** is connected to an exhaust gas purifying unit **50C**. The exhaust gas purifying unit **50C** communicates with the atmospheric air via the exhaust pipe **10**. A basic structure of the exhaust gas purifying unit **50C** is the same as the exhaust gas purifying unit **50A** in the modified example of the first embodiment which is illustrated in FIGS. **8** to **11**. In FIGS. **32** through **36**, the same components as those of the exhaust gas purifying unit **50A** are marked with the same numerals, and a different point will hereinafter be explained. Note that the NO_x catalyst **31** constitutes the exhaust gas purifying element also in the ninth embodiment.

In the exhaust gas purifying unit **50C** in the ninth embodiment, a SO_x absorbing agent **70** is provided approximately in an intermediate portion of the pipe **52** in the axial direction. Namely, in this exhaust gas purifying unit **50C**, the NO_x catalyst **31** and the SO_x absorbing agent are concentrically disposed. What can be exemplified as the SO_x absorbing agent **70** may be the NO_x storage-reduction catalyst having the SO_x absorbing power, the three-way catalyst, and the agent borne with platinum.

In the ninth embodiment, however, the NO_x storage-reduction catalyst having the SO_x absorbing power is used as the SO_x absorbing agent **70**. Accordingly, in the ninth embodiment, the SO_x absorbing agent **70** incorporates both of the SO_x absorbing/desorbing function and the NO_x purging function.

Further, in the case of the exhaust gas purifying unit **50C**, when the valve member **59** is held in the first closing position indicated by the solid line in FIG. **36**, the exhaust gas flows along the forward flow through the NO_x catalyst **31**. When the valve member **59** is held in the second closing position indicated by the one-dotted line in FIG. **36**, the exhaust gas flows along the backward flow through the NO_x catalyst **31**.

More specifically, FIG. **32** shows the state where the valve member **59** is located in the forward flow position. At this time, the exhaust gas flowing into the pipe **52** via the exhaust pipe **9** flows in the sequence such as the SO_x absorbing agent **70**→the opening **57**→the NO_x catalyst **31**→the sub-space **54**→the connection pipe **58**→the opening **58**→the pipe **52**→the exhaust pipe **10**.

Moreover, FIG. **33** shows the state where the valve member **59** is located in the backward flow position. At this time, the exhaust gas flowing into the pipe **52** via the exhaust pipe **9** flows in the sequence such as the SO_x absorbing agent **70**→the opening **56**→the connection pipe **58**→the sub-space **54**→the NO_x catalyst **31**→the sub-space space **55**→the opening **57**→the pipe **52**→the exhaust pipe **10**.

Accordingly, in the case of the exhaust gas purifying unit **50C**, the length of the flow path till the exhaust gas flows into the NO_x catalyst **31** is larger when the valve member **59** is set in the backward flow position than when the valve member **59** is set in the forward flow position. As a result, the decrease in the temperature of the exhaust gas till the

32

exhaust gas flows into the NO_x catalyst **31** is larger when the valve member **59** is set in the backward flow position than when the valve member **59** is set in the forward flow position.

Furthermore, in the case of the exhaust gas purifying unit **50C**, as shown in FIG. **34**, the valve member **59** can be held also in the neutral position set along the axial line of the pipe **52**. The structure is such that when the valve member **59** is thus located in the neutral position, there is produced no pressure difference between the inlet and the outlet of the NO_x catalyst **31**, and hence the exhaust gas does not substantially flows out to the sub-space **55** or the connection pipe **58** via the openings **56**, **57** of the pipe **52** and flows along the short path from the exhaust pipe **9** via the pipe **52** to the exhaust pipe **10**. Accordingly, the exhaust gas does not flow to the NO_x catalyst **31**.

Note that as explained in the sixth embodiment, FIG. **28** shows a relationship between the NO_x purging rate and the catalytic temperature of the NO_x catalyst (NO_x storage-reduction catalyst) **31** disposed in the annular space **53**.

In the exhaust emission control system in the ninth embodiment, the ECU **100** performs the control of switching over the position of the valve member **59** in the following manner.

To start with, the valve member **59** is located in the forward flow position as illustrated in FIG. **32**, in which case the load of the engine **1** is comparatively small, the temperature of the NO_x catalyst **31** is low (e.g., less than 400°C.), and the air/fuel ratio of the engine **1** is under the lean/rich spike control. If done in this way, it is possible to decrease both of the length of the flow path till the exhaust gas flows into the NO_x catalyst **31** and the drop in the temperature of the exhaust gas till the exhaust gas flows into the NO_x catalyst **31**. Hence, it is feasible to restrain the decrease in the temperature of the NO_x catalyst **31** and to keep the NO_x catalyst **31** at a temperature suited to the NO_x absorption and desorption.

Then, at this time, the exhaust gas flows through the SO_x absorbing agent **70** and is thereafter discharged via the NO_x catalyst **31**. Hence, SO_x contained in the exhaust gas is absorbed to the SO_x absorbing agent **70**, whereby the NO_x catalyst **31** is prevented from the SO_x poisoning. Further, NO_x contained in the exhaust gas is absorbed to both of the SO_x absorbing agent **70** and the NO_x catalyst **31**, and consequently the NO_x purging rate becomes extremely high.

Next, the valve member **59** is located in the backward flow position as illustrated in FIG. **33**, in which case the load of the engine **1** is comparatively large, the temperature of the NO_x catalyst **31** is high (e.g., over 400°C.) enough to deteriorate the NO_x purging rate, and the air/fuel ratio of the engine **1** is under the lean/rich spike control. With this operation, it is feasible to increase both of the length of the flow path till the exhaust gas flows into the NO_x catalyst **31** and the drop in the temperature of the exhaust gas till the exhaust gas flows into the NO_x catalyst **31**. Hence, it is possible to speed up the drop in the temperature of the NO_x catalyst **31** and, as a result, to keep the NO_x catalyst **31** at a temperature suited to the NO_x absorption and desorption.

Then, at this time also, the exhaust gas flows through the SO_x absorbing agent **70** and is thereafter discharged via the NO_x catalyst **31**. Hence, SO_x contained in the exhaust gas is absorbed to the SO_x absorbing agent **70**, whereby the NO_x catalyst **31** is prevented from the SO_x poisoning. Further, NO_x contained in the exhaust gas is absorbed to both of the SO_x absorbing agent **70** and the NO_x catalyst **31**, and consequently the NO_x purging rate becomes extremely high.

As discussed above, the connection pipe 58 functions as a cooling device for decreasing the temperature of the exhaust gas. Therefore, if this connection pipe 58 is installed in a position where the pipe 58 receives the traveling wind, the cooling effect can be enhanced.

Further, in a state where the engine 1 continues to be in the operation at the stoichiometric ratio as it does when starting up the engine 1 and during an accelerating operation and a high-speed high-load operation, the valve member 59 is, as illustrated in FIG. 34, located in the neutral position. With this setting, as described above, the exhaust gas flows along the short path from the exhaust pipe 9 via the pipe 52 to the exhaust pipe 10 but does not flow to the NO_x catalyst 31.

If the exhaust gas exhibiting the stoichiometric ratio continues to flow through the SO_x absorbing agent 70 for a predetermined period or longer, though it should be considered as a matter of course when the temperature of the exhaust gas is high, even when the temperature of the exhaust gas is low, SO_x is desorbed from the SO_x absorbing agent 70. Thus, if SO_x desorbed from the SO_x absorbing agent 70 flows to the NO_x catalyst 31, the NO_x catalyst 31 suffers the SO_x poisoning. Under this circumstance, if the exhaust gas of the stoichiometric ratio continues to flow, the valve member 59 is held in the neutral position, thereby preventing the exhaust gas from flowing to the NO_x catalyst 31.

SO_x desorbed from the SO_x absorbing agent 70 is reduced to SO₂, and the exhaust gas flows out to the exhaust pipe 10.

Note that the exhaust gas temperature detected by the exhaust gas temperature sensor 13 provided in the vicinity of the flange 52a of the exhaust gas purifying unit 50A, is a substitute for the catalytic temperature of the NO_x catalyst 31 in the ninth embodiment.

<Modified Examples Shown in FIGS. 37 to 41>

FIGS. 37 through 41 are diagrams each showing a modified example of the ninth embodiment of the exhaust emission control system, wherein the control system is constructed in a more compact configuration by eliminating the connection pipe 58 from the exhaust gas purifying unit 50C shown in FIGS. 32 to 36.

The following is an explanation of a difference of an exhaust gas purifying unit 50D in this modified example from the exhaust gas purifying unit 50C described above. The same components as those of the exhaust gas purifying unit 50C are marked with the same reference numerals in FIGS. 37 to 41, of which description is omitted. Note that the NO_x catalyst 31 constitutes the exhaust gas purifying element also in this modified example.

The exhaust gas purifying unit 50D in this modified example is constructed such that an annular space formed between the casing 51 and the pipe 52 is sectioned into three spatial areas, i.e., the annular sub-space 60 formed at an end portion on the side of the flange 52a, and the sub-spaces 62, 63 each taking a sectionally semicircular shape which are vertically divided into two spatial areas by the partition plate 61 extending from the casing 51 to the pipe 52 and fixed thereto.

Then, referring to FIG. 40, the NO_x catalyst 31 is disposed, in close proximity to the sub-space 60, within the semicircular sub-space 63 positioned upward. The sub-space 64 is formed in an area closer to the flange 52b than the NO_x catalyst 31 within the subspace 63, and the opening 57 of the pipe 52 communicates with the sub-space 64. On the other hand, referring again to FIG. 40, the semicircular sub-space 62 positioned downward communicates with the annular sub-space 60 and with the opening 56 of the pipe 52.

A positional relationship between the valve member 59 and the openings 56, 57, and two closing positions of the valve member 59 for closing the pipe 52, are absolutely the same as those in the exhaust gas purifying unit 50C described above. Then, explaining the case of the exhaust gas purifying unit 50D in the present modified example with reference to 36, when the valve member 59 is held in the first closing position indicated by the solid line in FIG. 36, the portion of the pipe 52, which is closer to the SO_x absorbing agent 70 than the valve member 59, is connected via the opening 57 to the sub-space 64. The portion of the pipe 52, which is closer to the flange 52b than the valve member 59, is connected via the opening 56 to the downward semicircular sub-space 62. In contrast with this, when the valve member 59 is held in the second closing position (backward flow position) indicated by the two-dotted line in FIG. 36, the portion of the pipe 52, which is closer to the SO_x absorbing agent 70 than the valve member 59, is connected via the opening 56 to the downward semicircular sub-space 62. The portion of the pipe 52, which is closer to the flange 52b than the valve member 59, is connected via the opening 57 to the sub-space 64.

FIGS. 37 and 39 are sectional views each showing the exhaust gas purifying unit 50D. FIG. 37 illustrates a state where the exhaust gas flows through the NO_x catalyst 31 along the forward flow. FIG. 38 illustrates a state where the exhaust gas flows through the NO_x catalyst 31 along the backward flow. FIG. 39 shows a state where the valve member 59 is set in the neutral position, and the exhaust gas takes a short path without flowing through the NO_x catalyst 31. It should be noted that when constructed as in the case of this exhaust gas purifying unit 50D, the operation of the exhaust emission control system is also the same as it operates with the exhaust gas purifying unit 50C provided in the ninth embodiment, and hence the explanation thereof is omitted.

<Modified Examples Shown in FIGS. 42 to 44>

FIGS. 42 to 44 are diagrams each showing a modified example of the ninth embodiment of the exhaust emission control system. A difference of the exhaust emission control system in this modified example from the exhaust emission control system in the mode shown in FIGS. 32 to 36, is only a point related to the exhaust pipe 9 and downstream-side portion thereof. This different point will be explained referring to FIGS. 42 to 44. Note that the NO_x catalyst 31 constitutes the exhaust gas purifying element also in this modified example.

A SO_x absorbing agent 71 is provided in the vicinity of the downstream-side end portion of the exhaust pipe 9. This absorbing agent 71 is composed of a three-way catalyst having a carrier including a basic site such as aluminum, and exhibits sufficient SO_x absorbing power.

The exhaust pipe 9 disposed more downstream than the SO_x absorbing agent 71 is connected to a first port of the emission switching valve 20 formed with four ports. The emission switching valve 20 is absolutely the same as the valve used in the exhaust emission control system in the first embodiment, and the configuration given downstream of the emission switching valve 20 is completely the same as that in the exhaust emission control system in the first embodiment. Then, the component provided downstream of the emission switching valve 20 are marked with the same numerals as those in the first embodiment, of which the explanation is omitted.

In this modified example, however, the valve member of the emission switching valve 20 can be held in the forward flow position when the exhaust gas flows along the forward

35

flow through the NO_x catalyst **31** as shown in FIG. **42**, the backward flow position when the exhaust gas flows along the backward flow through the NO_x catalyst **31** as shown in FIG. **43**, and the neutral flow position when the exhaust gas takes the short path from the exhaust pipe **9** to the exhaust pipe **10** without flowing through the NO_x catalyst **31** as shown in FIG. **44**.

In this modified example also, the length of the flow path till the exhaust gas flows into the catalyst **31** is larger than when the valve member of the emission switching valve **20** is set in the backward flow position than when set in the forward flow position. As a result, the decrease in the temperature of the exhaust gas till the exhaust gas flows into the catalyst **31** is larger when the valve member of the emission switching valve **20** is set in the backward flow position than when set in the forward flow position.

In the exhaust emission control system in this modified example, the ECU **100** performs the control of switching over the position of the valve member **59** in the following manner.

To start with, the valve member of the emission switching valve **20** is located in the forward flow position as illustrated in FIG. **42**, in which case the load of the engine **1** is comparatively small, the temperature of the NO_x catalyst **31** is low (e.g., less than 400° C.), and the air/fuel ratio of the engine **1** is under the lean/rich spike control. If done in this way, it is possible to decrease both of the length of the flow path till the exhaust gas flows into the NO_x catalyst **31** and the drop in the temperature of the exhaust gas till the exhaust gas flows into the NO_x catalyst **31**. Hence, it is feasible to restrain the decrease in the temperature of the NO_x catalyst **31** and to keep the NO_x catalyst **31** at a temperature suited to the NO_x absorption and desorption.

Then, at this time, the exhaust gas flows through the SO_x absorbing agent **71** and is thereafter discharged via the NO_x catalyst **31**. Hence, SO_x contained in the exhaust gas is absorbed to the SO_x absorbing agent **71**, whereby the NO_x catalyst **31** is prevented from the SO_x poisoning.

Next, the valve member of the emission switching valve **20** is located in the backward flow position as illustrated in FIG. **43**, in which case the load of the engine **1** is comparatively large, the temperature of the NO_x catalyst **31** is high (e.g., over 400° C.) enough to deteriorate the NO_x purging rate, and the air/fuel ratio of the engine **1** is under the lean/rich spike control. With this operation, it is feasible to increase both of the length of the flow path till the exhaust gas flows into the NO_x catalyst **31** and the drop in the temperature of the exhaust gas till the exhaust gas flows into the NO_x catalyst **31**. Hence, it is possible to speed up the drop in the temperature of the NO_x catalyst **31** and, as a result, to keep the NO_x catalyst **31** at a temperature suited to the NO_x absorption and desorption.

Then, at this time also, the exhaust gas flows through the SO_x absorbing agent **71** and is thereafter discharged via the NO_x catalyst **31**. Hence, SO_x contained in the exhaust gas is absorbed to the SO_x absorbing agent **71**, whereby the NO_x catalyst **31** is prevented from the SO_x poisoning.

Further, in a state where the engine **1** continues to be in the operation at the stoichiometric ratio as it does when starting up the engine **1** and during the accelerating operation and the high-speed high-load operation, the valve member of the emission switching valve **20** is, as illustrated in FIG. **44**, located in the neutral position. With this setting, as described above, the exhaust gas flows along the short path from the exhaust pipe **9** via the pipe **52** to the exhaust pipe **10** but does not flow to the NO_x catalyst **31**. Accordingly, even when SO_x

36

is desorbed from the SO_x absorbing agent **71**, it never happens that the NO_x catalyst **31** suffers the SO_x poisoning. Further, at this time, the exhaust gas is purified by three-way activation of the SO_x absorbing agent **71**. Consequently, there is no necessity for providing the sweeper.

Moreover, in the case of this modified example, if there might be a possibility in which SO_x absorbed to the SO_x absorbing agent **71** reaches a predetermined quantity and is desorbed from the SO_x absorbing agent **71** even in the rich spike for a short period of time under the lean/rich spike control, there is executed a regenerative process of desorbing SO_x from the SO_x absorbing agent **71**. During this regenerative process, the valve member of the emission switching valve **20** is located in the neutral position shown in FIG. **44**, thereby preventing the SO_x desorbed out of the SO_x absorbing agent **71** from flowing to the NO_x absorbing agent **31**.

Note that the regenerative process of the SO_x absorbing agent **71** is executed by setting the air/fuel ratio to the stoichiometric ratio and making the operation state of the engine **1** continue for the predetermined time in which the temperature of the exhaust gas rises over a predetermined temperature (e.g., 600° C. or higher).

Further, what may be judged as a regenerative timing of the SO_x absorbing agent **71** is a timing when, with a process of the ECU **100** estimating and integrating a SO_x absorption quantity of the SO_x absorbing agent **71** from a hysteresis of the operation state of the engine **1**, this estimated/integrated value reaches a predetermined quantity, or a timing when, with a process of an S sensor(SO_x sensor) being provided at the exhaust pipe **9** disposed downstream of the SO_x absorbing agent **71** and so structured as to be capable of detecting an SO₂ concentration in the exhaust gas which flows out of the SO_x absorbing agent **71**, an SO₂ desorption peak value when in the rich spike during an execution of the lean/rich spike control comes to a predetermined value.

Tenth Embodiment

Next, a tenth embodiment of the exhaust emission control system of the internal combustion engine according to the present invention will hereinafter be explained with reference to FIGS. **45** and **46**.

FIG. **45** is a diagram schematically showing a construction of the exhaust emission control system of the internal combustion engine in the tenth embodiment. The engine **1** is classified as a lean-burn gasoline engine, wherein the intake air is supplied to each of the cylinders via the intake pipe **2** and the intake manifold **3**. The fuel is injected out of the fuel injection valve **7** into each intake passageway communicating with each cylinder. The exhaust gas discharged from the respective cylinders is exhausted via the exhaust manifold **8** and the exhaust pipe **9**. The intake pipe **2** is provided with the throttle valve **4** including the throttle position sensor **5**, and the airflow meter **6**. The engine speed sensor **14** is provided in the engine **1**. Respective output signals of the throttle position sensor **5**, the airflow meter **6** and the engine speed sensor **14**, are outputted to the ECU **100**. The operation of the fuel injection valve **7** is controlled based on the output signals transmitted from the ECU **100**, and this construction is absolutely the same as that in the first embodiment discussed above. The exhaust pipe (the first exhaust passageway) **9** is connected to the first port of the emission switching valve (the flow direction switching unit) **20** formed with four ports. The second port of the emission switching valve **20** communicates with the atmospheric air via the exhaust pipe (the second exhaust passageway) **10**. This arrangement and the structure of the emission switching valve **20** are completely the same as those in the first embodiment.

The following is a different point of the exhaust emission control system in the tenth embodiment from the first embodiment.

In the tenth embodiment, the third port of the emission switching valve **20** is connected to the inlet **30a** of the catalytic converter **30** via the exhaust pipe (the third exhaust passageway) **11**. The outlet **30b** of the catalytic converter **30** is connected to an inlet **80a** of an HC adsorbing agent **80** via an exhaust pipe **12A**, and an outlet **80b** of the HC adsorbing agent **80** is connected to the fourth port of the emission switching valve **20** via an exhaust pipe **12B**. In the tenth embodiment, the exhaust pipes **12A**, **12B** constitute a fourth exhaust passageway, and HC adsorbing agent **80** is provided in the fourth exhaust passageway.

The catalytic converter **30** contains at least a catalyst (an exhaust gas purifying element) **32** capable of purging the exhaust gas of hydro carbon (HC). The NO_x storage-reduction catalyst and the selective reduction type NO_x catalyst may be exemplified as the catalyst **32**.

The HC adsorbing agent **80** has a nature of adsorbing the hydro carbon (HC) when a temperature of the adsorbing agent is a predetermined temperature or under, and desorbing HC adsorbed thereto when exceeding the predetermined temperature. The HC adsorbing agent **80** may be composed of a porous substance such as, e.g., zeolite etc.

An exhaust gas temperature sensor **81** for outputting to the ECU **100** an output signal corresponding to a temperature of the exhaust gas flowing within the exhaust pipe **12B**, is attached to the exhaust pipe **12B** in the vicinity of the outlet **80b** of the HC adsorbing agent **80**.

Note that the emission switching valve **20** is driven by the actuator **21**, thereby switching over the position of the valve member thereof. The actuator **21** is the same as that in the first embodiment in terms of its being controlled by the ECU **100**.

FIG. **45** shows the state where the valve member of the emission switching valve **20** is set in the forward flow position. At this time, the exhaust gas flows in the sequence such as the exhaust pipe **9**→the exhaust pipe **11**→the catalytic converter **30**→the exhaust pipe **12A**→the HC adsorbing agent **80**→the exhaust pipe **12B**→the exhaust pipe **10**, and is discharged into the atmospheric air. FIG. **46** shows the state where the valve member of the emission switching valve **20** is set in the backward flow position. At this time, the exhaust gas flows in the sequence such as the exhaust pipe **9**→the exhaust pipe **12B**→the HC adsorbing agent **80**→the exhaust pipe **12A**→the catalytic converter **30**→the exhaust pipe **11**→the exhaust pipe **10**, and is discharged into the atmospheric air.

In the exhaust emission control system in the tenth embodiment, the ECU **100** performs the control of switching over the position of the valve member of the emission switching valve **20** in the following manner.

Now, it is assumed that the HC adsorbing agent **80** adsorbs HC when the temperature of the adsorbing agent is 150° C. or lower and desorbs HC adsorbed thereto when exceeding 150° C. It is also assumed that the catalyst **32** exhibits a predetermined purging performance at over 200° C. defined as an active temperature. Further, the exhaust gas temperature detected by an exhaust gas temperature sensor **81** provided in the vicinity of the outlet **80b** of the HC adsorbing agent **80**, is a substitute for the adsorbing agent temperature of the HC adsorbing agent **80**.

At first, when the exhaust gas temperature is low as in the case of starting up the engine **1**, and when the exhaust gas temperature detected by the exhaust gas temperature sensor

81 is under 150° C., the valve member of the emission switching valve **20** is located in the forward flow position as shown in FIG. **45**. With this setting, the exhaust gas flows through the HC adsorbing agent **80** after passing through the catalytic converter **30**, and is discharged into the atmospheric air.

At this time, the catalyst **32** of the catalytic converter **30** does not yet reach the active temperature (200° C.), and consequently the exhaust gas is not substantially purified and flows through the catalytic converter **30**. Then, thereafter, when the exhaust gas flows through the HC adsorbing agent **80**, HC in the exhaust gas is adsorbed to the HC adsorbing agent **80**. Till the exhaust gas temperature detected by the exhaust gas temperature sensor **81** comes to 150° C., the exhaust gas continues to flow along the forward flow in this way. Accordingly, even when the temperature of the catalyst **32** does not reach the active temperature as in the case of the start-up at a low temperature, it never happens that HC in the exhaust gas is discharged into the atmospheric air.

Herein, the exhaust pipe **12A** extends between the catalytic converter **30** and the HC adsorbing agent **80**. The catalytic converter **30** and the HC adsorbing agent **80** have their own thermal capacities, and therefore a temperature of the catalyst **32** of the catalytic converter **30** is not the same as a temperature of the HC adsorbing agent **80** when the exhaust gas temperature is in the process of its rise. During the forward flow of the exhaust gas, the catalyst **32** assumes a higher temperature than that of the HC adsorbing agent **80**. Then, in accordance with the tenth embodiment, when the exhaust gas flows along the forward flow, and when the temperature of the HC adsorbing agent **80** reaches 150° C., a length of the exhaust pipe **12A** is set so that the temperature of the catalyst **32** comes to 200° C. or higher.

Next, when the exhaust gas temperature rises, and when the exhaust gas temperature detected by the exhaust gas temperature sensor **81** exceeds 150° C., it is required that the valve member of the emission switching valve **20** be, as illustrated in FIG. **46**, controlled in relation to the switching control. Note that as a method of adding the reducing agent, for example, the reducing agent may be added directly to the exhaust pipe **9**, or the fuel may be sub-injected out of the fuel injection valve during an expansion stroke or exhaust stroke of each cylinder of a diesel engine.

Moreover, the first to ninth embodiments aim at desorbing SO_x out of the NO_x catalyst or the SO_x adsorbing agent. For this purpose, when desorbing SO_x, the air/fuel ratio of the exhaust gas is set stoichiometric or rich, and the exhaust gas temperature is set high. These settings are not necessarily done depending on a category of the deposit to be desorbed out of the exhaust gas purifying element. For instance, if the deposit can be desorbed out of the exhaust gas purifying element simply by setting the exhaust gas at the stoichiometric ratio or the rich air/fuel ratio, the air/fuel ratio of the exhaust gas may merely be set stoichiometric or rich when removing the deposit, and there is no necessity for raising the exhaust gas temperature. Further, if the deposit can be desorbed out of the exhaust gas purifying element simply by increasing the temperature of, the exhaust gas temperature may be merely increased, and there is no necessity for setting the exhaust gas at the stoichiometric ratio or rich air/fuel ratio.

According to the exhaust emission control system of the internal combustion engine of the present invention, it is feasible to selectively switch over the flow direction of the exhaust gas flowing through the exhaust gas purifying ele-

ment in either the forward flow direction or the backward flow direction simply by switching over the flow direction switching device to the first or second position. This might simplify the structure of the exhaust emission control system, which leads to a decrease in the costs.

In the exhaust emission control system of the internal combustion engine according to the present invention, the exhaust purifying element is structured as the NO_x storage-reduction catalyst, and, when in the SO_x desorbing process of desorbing SO_x absorbed to the NO_x storage-reduction catalyst from this NO_x storage-reduction catalyst, the flow direction switching device is switched over to the first or second position, thus changing the flow direction of the exhaust gas flowing through the NO_x storage-reduction catalyst to a direction opposite to that when absorbing NO_x. In this case, SO_x can be desorbed at a high efficiency from the NO_x storage-reduction catalyst.

In the exhaust emission control system of the internal combustion engine according to the present invention, as for the exhaust gas purifying element composed of the NO_x storage-reduction catalyst, the NO_x storage-reduction catalyst disposed on the inlet-side in the flow direction of the exhaust gas when absorbing NO_x, exhibits higher SO_x absorbing power than that of the NO_x storage-reduction catalyst disposed on the outlet-side in the flow direction of the exhaust gas when absorbing NO_x. In this case, SO_x can be desorbed out of the NO_x storage-reduction catalyst at the high efficiency.

In the exhaust emission control system of the internal combustion engine according to the present invention, the exhaust gas purifying element is composed of the NO_x storage-reduction catalyst, there is provided a heating element for heating the portion close to the inlet of the NO_x storage-reduction catalyst in the flow direction of the exhaust gas when absorbing NO_x. In this case, the SO_x desorption out of the NO_x storage-reduction catalyst can be more speeded up.

In the exhaust emission control system of the internal combustion engine according to the present invention, the exhaust gas purifying element is composed of the NO_x storage-reduction catalyst, and the flow direction switching device is switched over to the first or second position, whereby lengths of the third exhaust passageway and of the fourth exhaust passageway are set so that a distance from the internal combustion engine to the NO_x storage-reduction catalyst is shorter [than when in the SO_x desorbing process] *when in the SO_x desorbing process than when absorbing NO_x*. In this case, it is feasible to speed up both of a rise in temperature of the NO_x storage-reduction catalyst and the SO_x desorption when in the SO_x desorbing process.

In the exhaust emission control system of the internal combustion engine according to the present invention, the exhaust gas purifying element is composed of the NO_x storage-reduction catalyst, and the sweeper is provided at the second exhaust passageway. In this case, even when the flow of the exhaust gas is bypassed without flowing through the exhaust gas purifying element in the process of the switching process by the flow direction switching device, the exhaust gas is purified by the sweeper and can be then discharged into the atmospheric air.

In the exhaust emission control system of the internal combustion engine according to the present invention, the exhaust gas purifying element is composed of the NO_x storage-reduction catalyst, another catalyst is provided at the first exhaust passageway, and the sweeper is provided at the second exhaust passageway. The flow direction switching

device is switched over to a third position for connecting the first port to the second port for an initial predetermined time during the SO_x desorbing process, and switches over the flow direction of the exhaust gas flowing through the NO_x storage-reduction catalyst in a direction opposite to that when absorbing NO_x after the predetermined has elapsed. In this case, even when SO_x is desorbed from another catalyst at the initial stage of the SO_x desorbing process, SO_x desorbed therefrom does not flow into the NO_x storage-reduction catalyst, and hence the NO_x storage-reduction catalyst is prevented from SO_x poisoning. Besides, the sweeper is capable of purifying SO_x desorbed from another catalyst.

If the NO_x storage-reduction catalyst and the sweeper are integrated into one unit so that the exhaust gas can not flow therebetween and the heat can be transmitted therebetween, a temperature of the sweeper can be kept high, and a purging performance can be enhanced.

In the exhaust emission control system of the internal combustion engine according to the present invention, the exhaust gas purifying element is composed of the NO_x storage-reduction catalyst, and the lengths of the third and fourth exhaust passageways are set so that the distance from the internal combustion engine to the exhaust gas purifying element becomes different by switching over the flow direction switching device to the first or second position. Then, the flow direction switching device is switched over by selecting a flow path having a shorter distance from the internal combustion engine to the NO_x storage-reduction catalyst during the SO_x desorbing process of desorbing SO_x absorbed to the NO_x storage-reduction catalyst out of this NO_x storage-reduction catalyst. In this case, the higher-temperature exhaust gas can be flowed through the NO_x storage-reduction catalyst. As a result, SO_x can be desorbed at a higher efficiency.

In the exhaust emission control system of the internal combustion engine according to the present invention, the exhaust gas purifying element is composed of the NO_x storage-reduction catalyst, and the lengths of the third and fourth exhaust passageways are set so that the distance from the internal combustion engine to the exhaust gas purifying element becomes different by switching over the flow direction switching device to the first or second position. Then, the flow direction switching device is switched over by selecting a flow path having a longer distance from the internal combustion engine to the NO_x storage-reduction catalyst when the NO_x storage-reduction catalyst absorbs NO_x and when the exhaust gas temperature or the temperature of the NO_x storage-reduction catalyst is over a predetermined temperature, and selecting a flow path having a shorter distance from the internal combustion engine to the NO_x storage-reduction catalyst when the NO_x storage-reduction catalyst absorbs NO_x and when the exhaust gas temperature or the temperature of the NO_x storage-reduction catalyst is lower than the predetermined temperature. In this case, the NO_x storage-reduction catalyst can be kept within a temperature range suited to the NO_x absorption, and the NO_x purging rate can be enhanced.

In the exhaust emission control system of the internal combustion engine according to the present invention, the exhaust gas purifying element is composed of the NO_x storage-reduction catalyst, and the lengths of the third and fourth exhaust passageways are set so that the distance from the internal combustion engine to the exhaust gas purifying element becomes different by switching over the flow direction switching device to the first or second position. The sweeper is provided at the second exhaust passageway, and the flow direction switching device can be switched over to a

third position in which the first port can be connected to the second port. When *the exhaust gas temperature or the temperature of the NO_x storage-reduction catalyst is higher than a NO_x absorbable temperature range of the NO_x storage-reduction catalyst*, the flow direction switching device is selectively switched over to the third position. In this case, the high-temperature exhaust gas can take a short path from the first exhaust passageway to the second exhaust passageway without flowing through the NO_x storage-reduction catalyst, thereby preventing the NO_x storage-reduction catalyst from being deteriorated due to the high temperature.

In the exhaust emission control system of the internal combustion engine according to the present invention, a cooling device for cooling the exhaust gas is provided at either the third exhaust passageway or the fourth exhaust passageway, which increases the distance from the internal combustion engine to the NO_x storage-reduction catalyst. In this case, the NO_x storage-reduction catalyst can be held more surely within the temperature range suited to the NO_x absorption by the NO_x storage-reduction catalyst.

In the exhaust emission control system of the internal combustion engine according to the present invention, the exhaust gas purifying element is composed of the NO_x storage-reduction catalyst, and the first exhaust passageway is provided with the SO_x absorbing agent for absorbing SO_x when the air/fuel ratio of the inflow exhaust gas is lean, and desorbs SO_x absorbed thereto when a concentration of oxygen in the inflow exhaust gas decreases. The flow direction switching device can be switched over to the third position in which to connect the first port to the second port, and is selectively switched over to the third position when the internal combustion engine comes to a continuous stoichiometric ratio operation. In this case, even if the exhaust gas exhibiting the stoichiometric ratio flows into the SO_x absorbing agent and SO_x is desorbed from the SO_x absorbing agent, it is possible to prevent SO_x from flowing into the NO_x storage-reduction catalyst and to prevent the NO_x storage-reduction catalyst from suffering the SO_x poisoning.

If the SO_x absorbing agent and the NO_x storage-reduction catalyst are concentrically disposed, the exhaust emission control system can be structured in a compact configuration.

In the exhaust emission control system of the internal combustion engine according to the present invention, the exhaust gas purifying element is composed of the NO_x storage-reduction catalyst, and the first exhaust passageway is provided with a three-way catalyst exhibiting SO_x absorbing power. The flow direction switching device can be switched over to the third position in which to connect the first port to the second port, and is selectively switched over to the third position when the internal combustion engine comes to a continuous stoichiometric ratio operation. In this case, even if the exhaust gas exhibiting the stoichiometric ratio flows into the three-way catalyst and SO_x is desorbed from the three-way catalyst, it is possible to prevent SO_x from flowing into the NO_x storage-reduction catalyst and to prevent the NO_x storage-reduction catalyst from suffering from the SO_x poisoning.

In the exhaust emission control system of the internal combustion engine according to the present invention, the exhaust gas purifying element is composed of the catalyst, any one of the third and fourth exhaust passageways is provided with an HC adsorbing agent for adsorbing hydro carbon. The flow direction switching device is switched over to select a flow path on which the catalyst is positioned more upstream than the HC adsorbing agent when the temperature of the exhaust gas or of the HC adsorbing agent is in a

temperature region where the HC adsorbing agent adsorbs the hydro carbon, and to select a flow path on which the HC adsorbing agent is positioned more upstream than the catalyst when the temperature of the exhaust gas or of the HC adsorbing agent is in a temperature region where the HC adsorbing agent desorbs the hydro carbon. In this case, HC can not be discharged even when the temperature of the exhaust gas is low.

The many features and advantages of the invention are apparent from the detailed specification and, thus, it is intended by the appended claims to cover all such features and advantages of the invention which fall within the true spirit and scope of the invention. Further, since numerous modifications and changes will readily occur to those skilled in the art, it is not desired to limit the invention to the exact construction and operation illustrated and described, and accordingly all suitable modifications and equivalents may be resorted to, falling within the scope of the invention.

What is claimed is:

[1. An exhaust emission control system of an internal combustion engine, comprising:

exhaust gas purifying means provided in an exhaust passageway of said internal combustion engine;

flow direction switching means including four ports and provided at an exhaust passageway disposed more upstream than said exhaust gas purifying means;

a first exhaust passageway connected to said internal combustion engine and further to a first port of said flow direction switching means;

a second exhaust passageway communicating with the atmospheric air and further to a second port of said flow direction switching means;

a third exhaust passageway connected to one side of said exhaust gas purifying means and further to a third port of said flow direction switching means; and

a fourth exhaust passageway connected to the other side of said exhaust gas purifying means and further to a fourth port of said flow direction switching means,

wherein said flow direction switching means can be switched over to a first position for permitting the exhaust gas to flow in a direction through said exhaust gas purifying means by connecting the first port to the third port and connecting the second port to the fourth port, to a second position for permitting the exhaust gas to flow in a direction opposite to the first direction through said exhaust gas purifying means by connecting the first port to the fourth port and connecting the second port to the third port, and to a third position in which the first port is connectable to the second port.]

[2. An exhaust emission control system of an internal combustion engine according to claim 1, wherein said exhaust gas purifying means is an NO_x storage-reduction catalyst for absorbing NO_x when an air/fuel ratio of the inflow exhaust gas is lean, and desorbing NO_x absorbed thereto when a concentration of oxygen in the inflow exhaust gas decreases.]

3. [An exhaust emission control system of an internal combustion engine according to claim 2.] *An exhaust emission control system of an internal combustion engine, comprising:*

exhaust gas purifying means provided in an exhaust passageway of said internal combustion engine;

flow direction switching means including four ports and provided at an exhaust passageway disposed more upstream than said exhaust gas purifying means;

43

a first exhaust passageway connected to said internal combustion engine and further to a first port of said flow direction switching means;

a second exhaust passageway communicating with the atmospheric air and further to a second port of said flow direction switching means;

a third exhaust passageway connected to one side of said exhaust gas purifying means and further to a third port of said flow direction switching means; and

a fourth exhaust passageway connected to the other side of said exhaust gas purifying means and further to a fourth port of said flow direction switching means,

wherein said flow direction switching means is switched over to a first position for permitting the exhaust gas to flow in a first direction through said exhaust gas purifying means by connecting the first port to the third port and connecting the second port to the fourth port, to a second position for permitting the exhaust gas to flow in a direction opposite to the first direction through said exhaust gas purifying means by connecting the first port to the fourth port and connecting the second port to the third port, and to a third position in which the first port is connectable to the second port,

wherein said exhaust gas purifying means is an NO_x storage-reduction catalyst for absorbing NO_x when an air/fuel ratio of the inflow exhaust gas is lean, and desorbing NO_x absorbed thereto when a concentration of oxygen in the inflow exhaust gas decreases,

wherein when in a SO_x desorbing process of desorbing SO_x absorbed to said NO_x storage-reduction catalyst from said NO_x storage-reduction catalyst, said flow direction switching means is switched over to the first position and the second position, thereby making a flow direction of the exhaust gas flowing through said NO_x storage-reduction catalyst opposite to the direction when absorbing NO_x .

4. An exhaust emission control system of an internal combustion engine according to claim 3, wherein said exhaust gas purifying means composed of said NO_x storage-reduction catalyst is such that, a NO_x storage-reduction catalyst disposed on inlet side in the flow direction of the exhaust gas when absorbing NO_x exhibits higher SO_x absorbing power than that of an NO_x storage-reduction catalyst disposed on an outlet side in the flow direction of the exhaust gas when absorbing NO_x .

5. An exhaust emission control system of an internal combustion engine according to claim 3, further comprising heating means for heating a portion close to an inlet of said NO_x storage-reduction catalyst in the flow direction of the exhaust gas when said NO_x storage-reduction catalyst absorbs NO_x .

6. An exhaust emission control system of an internal combustion engine according to claim 3, wherein the switch-over of said flow direction switching means when in the SO_x desorbing process is executed when an exhaust gas temperature or a catalytic temperature of said NO_x storage-reduction catalyst rises.

7. An exhaust emission control system of an internal combustion engine according to claim 3, wherein lengths of said third exhaust passageway and of said fourth exhaust passageway are set so that a distance from said internal combustion engine to said NO_x storage-reduction catalyst is shorter when in the SO_x desorbing process than when absorbing NO_x [than when in the SO_x desorbing process] by switching over said flow direction switching means to the first position or the second position.

44

[8. An exhaust emission control system of an internal combustion engine according to claim 2, wherein a sweeper is provided at said second exhaust passageway.]

9. [An exhaust emission control system of an internal combustion engine according to claim 8.] An exhaust emission control system of an internal combustion engine, comprising:

exhaust gas purifying means provided in an exhaust passageway of said internal combustion engine;

flow direction switching means including four ports and provided at an exhaust passageway disposed more upstream than said exhaust gas purifying means;

a first exhaust passageway connected to said internal combustion engine and further to a first port of said flow direction switching means;

a second exhaust passageway communicating with the atmospheric air and further to a second port of said flow direction switching means;

a third exhaust passageway connected to one side of said exhaust gas purifying means and further to a third port of said flow direction switching means; and

a fourth exhaust passageway connected to the other side of said exhaust gas purifying means and further to a fourth port of said flow direction switching means,

wherein said flow direction switching means is switched over to a first position for permitting the exhaust gas to flow in a first direction through said exhaust gas purifying means by connecting the first port to the third port and connecting the second port to the fourth port, to a second position for permitting the exhaust gas to flow in a direction opposite to the first direction through said exhaust gas purifying means by connecting the first port to the fourth port and connecting the second port to the third port, and to a third position in which the first port is connectable to the second port,

wherein said exhaust gas purifying means is an NO_x storage-reduction catalyst for absorbing NO_x when an air/fuel ratio of the inflow exhaust gas is lean, and desorbing NO_x absorbed thereto when a concentration of oxygen in the inflow exhaust gas decreases,

wherein a sweeper is provided at said second exhaust passageway, and

wherein said sweeper is a selective reduction type NO_x catalyst for reducing or dissolving NO_x under an existence of hydro carbon in an over-oxygen atmosphere.

10. [An exhaust emission control system of an internal combustion engine according to claim 8.] An exhaust emission control system of an internal combustion engine, comprising:

exhaust gas purifying means provided in an exhaust passageway of said internal combustion engine;

flow direction switching means including four ports and provided at an exhaust passageway disposed more upstream than said exhaust gas purifying means;

a first exhaust passageway connected to said internal combustion engine and further to a first port of said flow direction switching means;

a second exhaust passageway communicating with the atmospheric air and further to a second port of said flow direction switching means;

a third exhaust passageway connected to one side of said exhaust gas purifying means and further to a third port of said flow direction switching means; and

a fourth exhaust passageway connected to the other side of said exhaust gas purifying means and further to a fourth port of said flow direction switching means,

45

wherein said flow direction switching means is switched over to a first position for permitting the exhaust gas to flow in a first direction through said exhaust gas purifying means by connecting the first port to the third port and connecting the second port to the fourth port, to a second position for permitting the exhaust gas to flow in a direction opposite to the first direction through said exhaust gas purifying means by connecting the first port to the fourth port and connecting the second port to the third port, and to a third position in which the first port is connectable to the second port,

wherein said exhaust gas purifying means is an NO_x storage-reduction catalyst for absorbing NO_x when an air/fuel ratio of the inflow exhaust gas is lean, and desorbing NO_x absorbed thereto when a concentration of oxygen in the inflow exhaust gas decreases,

wherein a sweeper is provided at said second exhaust passageway,

wherein another catalyst is provided in said first exhaust passageway, and

said flow direction switching means is switched over to the third position for connecting the first port to the second port for an initial predetermined time during the SO_x desorbing process and, after the predetermined time has elapsed, switched over to make the flow direction of the exhaust gas flowing through said NO_x storage-reduction catalyst opposite to the direction when absorbing NO_x .

11. [An exhaust emission control system of an internal combustion engine according to claim 8.] *An exhaust emission control system of an internal combustion engine, comprising:*

exhaust gas purifying means provided in an exhaust passageway of said internal combustion engine;

flow direction switching means including four ports and provided at an exhaust passageway disposed more upstream than said exhaust gas purifying means;

a first exhaust passageway connected to said internal combustion engine and further to a first port of said flow direction switching means;

a second exhaust passageway communicating with the atmospheric air and further to a second port of said flow direction switching means;

a third exhaust passageway connected to one side of said exhaust gas purifying means and further to a third port of said flow direction switching means; and

a fourth exhaust passageway connected to the other side of said exhaust gas purifying means and further to a fourth port of said flow direction switching means,

wherein said flow direction switching means is switched over to a first position for permitting the exhaust gas to flow in a first direction through said exhaust gas purifying means by connecting the first port to the third port and connecting the second port to the fourth port, to a second position for permitting the exhaust gas to flow in a direction opposite to the first direction through said exhaust gas purifying means by connecting the first port to the fourth port and connecting the second port to the third port, and to a third position in which the first port is connectable to the second port,

wherein said exhaust gas purifying means is an NO_x storage-reduction catalyst for absorbing NO_x when an air/fuel ratio of the inflow exhaust gas is lean, and desorbing NO_x absorbed thereto when a concentration of oxygen in the inflow exhaust gas decreases, and

46

wherein a sweeper is provided at said second exhaust passageway,

wherein said NO_x storage-reduction catalyst and said sweeper are integrated into one unit so that the exhaust gas [can not] cannot flow therebetween and the heat [can be] is transmitted therebetween.

12. [An exhaust emission control system of an internal combustion engine according to claim 2.] *An exhaust emission control system of an internal combustion engine, comprising:*

exhaust gas purifying means provided in an exhaust passageway of said internal combustion engine;

flow direction switching means including four ports and provided at an exhaust passageway disposed more upstream than said exhaust gas purifying means;

a first exhaust passageway connected to said internal combustion engine and further to a first port of said flow direction switching means;

a second exhaust passageway communicating with the atmospheric air and further to a second port of said flow direction switching means;

a third exhaust passageway connected to one side of said exhaust gas purifying means and further to a third port of said flow direction switching means; and

a fourth exhaust passageway connected to the other side of said exhaust gas purifying means and further to a fourth port of said flow direction switching means,

wherein said flow direction switching means is switched over to a first position for permitting the exhaust gas to flow in a first direction through said exhaust gas purifying means by connecting the first port to the third port and connecting the second port to the fourth port, to a second position for permitting the exhaust gas to flow in a direction opposite to the first direction through said exhaust gas purifying means by connecting the first port to the fourth port and connecting the second port to the third port, and to a third position in which the first port is connectable to the second port,

wherein said exhaust gas purifying means is an NO_x storage-reduction catalyst for absorbing NO_x when an air/fuel ratio of the inflow exhaust gas is lean, and desorbing NO_x absorbed thereto when a concentration of oxygen in the inflow exhaust gas decreases,

wherein said first exhaust passageway is provided with a SO_x absorbing agent for absorbing SO_x when the air/fuel ratio of the inflow exhaust gas is lean, and desorbs SO_x absorbed thereto when a concentration of oxygen in the inflow exhaust gas decreases, and

said flow direction switching means [can be] is switched over to the third position in which to connect the first port to the second port, and is selectively switched over to the third position when said internal combustion engine comes to a continuous stoichiometric ratio operation.

13. An exhaust emission control system of an internal combustion engine according to claim 12, wherein said SO_x absorbing agent and said NO_x storage-reduction catalyst are concentrically disposed.

14. [An exhaust emission control system of an internal combustion engine according to claim 2.] *An exhaust emission control system of an internal combustion engine, comprising:*

exhaust gas purifying means provided in an exhaust passageway of said internal combustion engine;

flow direction switching means including four ports and provided at an exhaust passageway disposed more upstream than said exhaust gas purifying means;

a first exhaust passageway connected to said internal combustion engine and further to a first port of said flow direction switching means;

a second exhaust passageway communicating with the atmospheric air and further to a second port of said flow direction switching means;

a third exhaust passageway connected to one side of said exhaust gas purifying means and further to a third port of said flow direction switching means; and

a fourth exhaust passageway connected to the other side of said exhaust gas purifying means and further to a fourth port of said flow direction switching means,

wherein said flow direction switching means is switched over to a first position for permitting the exhaust gas to flow in a first direction through said exhaust gas purifying means by connecting the first port to the third port and connecting the second port to the fourth port, to a second position for permitting the exhaust gas to flow in a direction opposite to the first direction through said exhaust gas purifying means by connecting the first port to the fourth port and connecting the second port to the third port, and to a third position in which the first port is connectable to the second port,

wherein said exhaust gas purifying means is an NO_x storage-reduction catalyst for absorbing NO_x when an air/fuel ratio of the inflow exhaust gas is lean, and desorbing NO_x absorbed thereto when a concentration of oxygen in the inflow exhaust gas decreases,

wherein said first exhaust passageway is provided with a three-way catalyst exhibiting SO_x absorbing power, and said flow direction switching means [can be] is switched over to the third position in which the first port is connectable to the second port, and is selectively switched over to the third position when said internal combustion engine comes to a continuous stoichiometric ratio operation.

[15. An exhaust emission control system of an internal combustion engine according to claim 1, wherein lengths of said third exhaust passageway and of said fourth exhaust passageway are set so that a distance from said internal combustion engine to said exhaust gas purifying means becomes different by switching over said flow direction switching means to the first position or the second position.]

16. An exhaust emission control system of an internal combustion engine according to claim 13, wherein the switch-over of said flow direction switching means is executed based on an exhaust gas temperature or a temperature of said exhaust gas purifying means.

17. An exhaust emission control system of an internal combustion engine according to claim 16, wherein said exhaust gas purifying means is an NO_x storage-reduction catalyst for absorbing NO_x when an air/fuel ratio of the inflow exhaust gas is lean, and desorbing NO_x absorbed thereto when a concentration of oxygen in the inflow exhaust gas decreases.

18. An exhaust emission control system of an internal combustion engine according to claim 17, wherein said flow

direction switching means is switched over by selecting a flow path having a shorter distance from said internal combustion engine to said NO_x storage-reduction catalyst when in the SO_x desorbing process of desorbing SO_x desorbed to said NO_x storage-reduction catalyst from said NO_x storage-reduction catalyst.

19. An exhaust emission control system of an internal combustion engine according to claim 17, wherein said flow direction switching means is switched over by selecting a flow path having a longer distance from said internal combustion engine to said NO_x storage-reduction catalyst when said NO_x storage-reduction catalyst absorbs NO_x and when the exhaust gas temperature or the catalytic temperature of said NO_x storage-reduction catalyst is over a predetermined temperature, and selecting a flow path having a shorter distance from said internal combustion engine to said NO_x storage-reduction catalyst when said NO_x storage-reduction catalyst absorbs NO_x and when the exhaust gas temperature or the catalytic temperature is lower than the predetermined temperature.

20. An exhaust emission control system of an internal combustion engine according to claim 17, wherein a cooling device for cooling the exhaust gas is provided at either said third exhaust passageway or said fourth exhaust passageway, which increases the distance from said internal combustion engine to said NO_x storage-reduction catalyst.

21. An exhaust emission control system of an internal combustion engine according to claim 17, wherein a sweeper is provided at said second exhaust passageway, and said flow direction switching means [can be] is switched over to a third position in which the first port can be connected to the second port,

when the exhaust gas temperature or the catalytic temperature of said NO_x storage-reduction catalyst is higher than a NO_x absorbable temperature range of said NO_x storage-reduction catalyst, said flow direction switching means is selectively switched over to the third position.

[22. An exhaust emission control system of an internal combustion engine according to claim 1, wherein said exhaust gas purifying means is a catalyst,

any one of said third exhaust passageway and of said fourth exhaust passageway is provided with an HC adsorbing agent for adsorbing hydro carbon, and

said flow direction switching means is switched over to select a flow path on which said catalyst is positioned more upstream than said HC adsorbing agent when the temperature of the exhaust gas or of said HC adsorbing agent is in a temperature region where said HC adsorbing agent adsorbs the hydro carbon, and to select a flow path on which said HC adsorbing agent is positioned more upstream than said catalyst when the temperature of the exhaust gas or of said HC adsorbing agent is in a temperature region where said HC adsorbing agent desorbs the hydro carbon.]