

US00RE42148E

(19) **United States**
(12) **Reissued Patent**
Sheraizin et al.

(10) **Patent Number:** **US RE42,148 E**
(45) **Date of Reissued Patent:** **Feb. 15, 2011**

(54) **METHOD AND APPARATUS FOR VISUAL LOSSLESS IMAGE SYNTACTIC ENCODING**

(76) Inventors: **Semion Sheraizin**, 28B Harnagen Street, Mazkeret Batya 78604 (IL); **Vitaly Sheraizin**, 28B Harnagen Street, Mazkeret Batya 78604 (IL)

(21) Appl. No.: **12/196,180**

(22) Filed: **Aug. 21, 2008**

Related U.S. Patent Documents

Reissue of:

(64) Patent No.: **7,095,903**
Issued: **Aug. 22, 2006**
Appl. No.: **11/036,062**
Filed: **Jan. 18, 2005**

(63) Continuation of application No. 10/121,685, filed on Apr. 15, 2002, now Pat. No. 6,952,500, which is a continuation of application No. 09/524,618, filed on Mar. 14, 2000, now Pat. No. 6,473,532.

(30) **Foreign Application Priority Data**

Jan. 23, 2000 (IL) 134182

(51) **Int. Cl.**
G06K 9/38 (2006.01)

(52) **U.S. Cl.** **382/270**; 382/263

(58) **Field of Classification Search** 382/162, 382/263, 264, 270; 375/240.29

See application file for complete search history.

(56) **References Cited**

U.S. PATENT DOCUMENTS

2,697,758 A 8/1950 Little, Jr.
(Continued)

FOREIGN PATENT DOCUMENTS

EP 0502615 9/1992
(Continued)

OTHER PUBLICATIONS

“Notice of Allowance”, U.S. Appl. No. 12/316,168, (Jun. 1, 2010), 9 pages.

(Continued)

Primary Examiner—Phuoc Tran

(57) **ABSTRACT**

A visual perception threshold unit for image processing identifies a plurality of visual perception threshold levels to be associated with the pixels of a video frame, wherein the threshold levels define contrast levels above which a human eye can distinguish a pixel from among its neighboring pixels of the video frame. The present invention also includes a method of generating visual perception thresholds by analysis of the details of the video frames, estimating the parameters of the details, and defining a visual perception threshold for each detail in accordance with the estimated detail parameters. The present invention further includes a method of describing images by determining which details in the image can be distinguished by the human eye and which ones can only be detected by it.

31 Claims, 15 Drawing Sheets

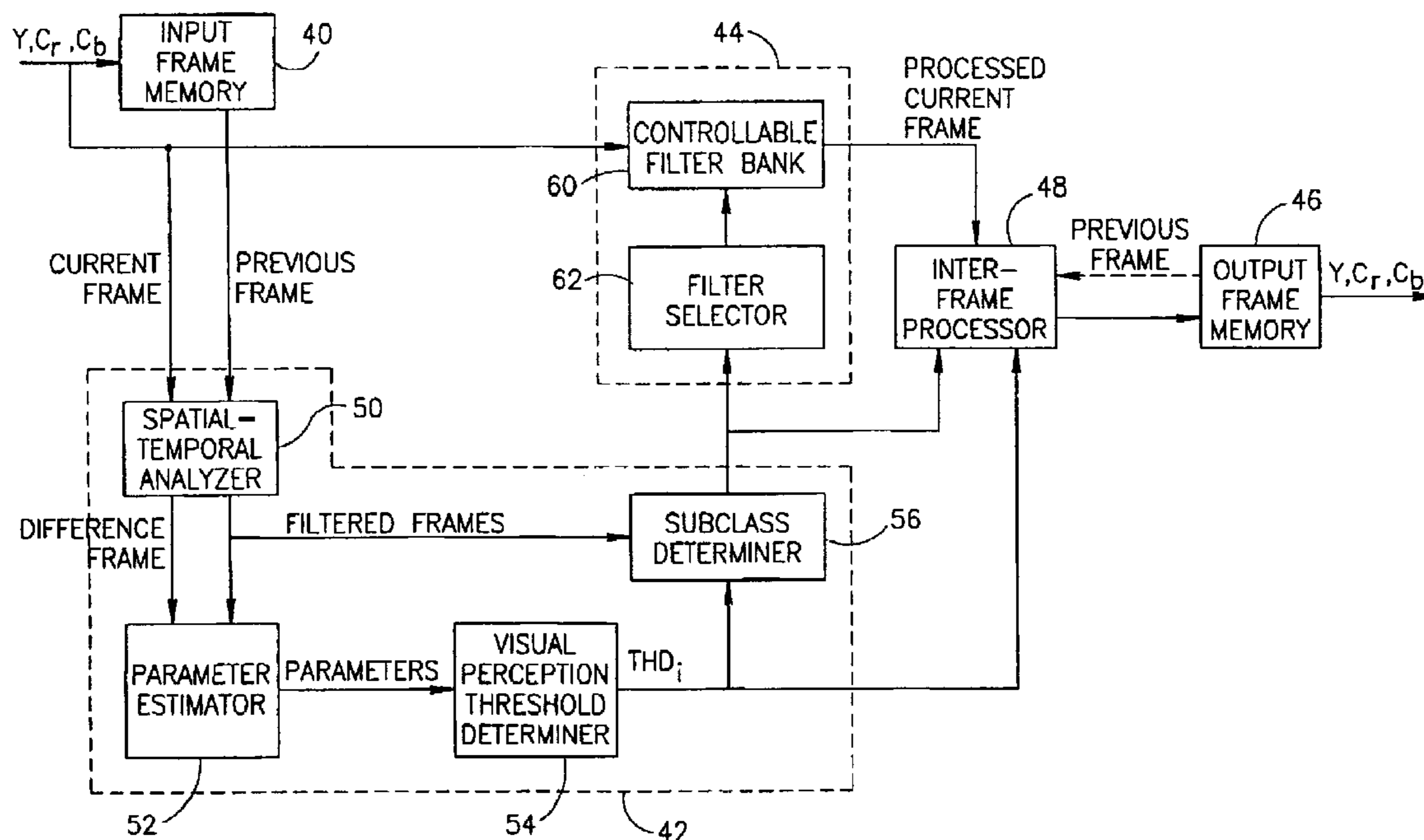

US RE42,148 E

Page 2

U.S. PATENT DOCUMENTS

3,961,133	A	6/1976	Bennett	6,259,489	B1	7/2001	Flannaghan et al.
4,855,825	A	8/1989	Haikonen et al.	6,282,299	B1	8/2001	Tewfik et al.
4,947,255	A	8/1990	Jackson et al.	6,320,676	B1	11/2001	Yoshidome
5,012,333	A	4/1991	Lee	6,366,705	B1	4/2002	Chiu et al.
5,126,847	A	6/1992	Kori	6,385,647	B1	5/2002	Willis et al.
5,194,943	A	3/1993	Tomita et al.	6,404,460	B1	6/2002	Chen et al.
5,245,445	A	9/1993	Fujisawa	6,463,173	B1	10/2002	Tretter
5,301,016	A	4/1994	Gehrmann	6,466,912	B1	10/2002	Johnston
5,339,171	A	8/1994	Fujisawa	6,473,532	B1	10/2002	Sheraizin
5,341,442	A	8/1994	Barrett	6,509,158	B1	1/2003	Schwartz
5,384,601	A	1/1995	Yamashita et al.	6,522,425	B2	2/2003	Yoshidome
5,404,174	A	4/1995	Sugahara	6,554,181	B1	4/2003	Dammers et al.
5,428,398	A	6/1995	Faroudja	6,559,826	B1	5/2003	Mendelson et al.
5,467,404	A	11/1995	Vuylsteke	6,567,116	B1	5/2003	Aman et al.
5,488,675	A	1/1996	Hanna	6,580,825	B2	6/2003	Bhaskar
5,491,514	A	2/1996	Fukuda	6,610,256	B2	8/2003	Schwartz
5,491,517	A	2/1996	Kreitman et al.	6,628,327	B1	9/2003	Aoki et al.
5,491,519	A	2/1996	Kim	6,643,398	B2	11/2003	Moriwaki
5,510,824	A	4/1996	Nelson	6,707,487	B1	3/2004	Aman
5,537,510	A	7/1996	Kim	6,728,317	B1	4/2004	Demos
5,539,475	A	7/1996	Sadjadian et al.	6,753,929	B1	6/2004	Sheraizin
5,542,008	A	7/1996	Sugahara et al.	6,757,449	B1	6/2004	Loce
5,555,557	A	9/1996	Mailloux	6,782,287	B2	8/2004	Grzeszczuk
5,557,340	A	9/1996	Millward	6,835,693	B2	12/2004	Bourdelaïs et al.
5,565,921	A	10/1996	Sasaki et al.	6,845,181	B2	1/2005	Dupin et al.
5,566,251	A	10/1996	Hanna et al.	6,847,391	B1	1/2005	Kassatly
5,586,200	A	12/1996	Devaney et al.	6,873,442	B1	3/2005	Gindele et al.
5,592,226	A	1/1997	Lee et al.	6,940,545	B1	9/2005	Ray et al.
5,613,035	A	3/1997	Kim	6,940,903	B2	9/2005	Zhao et al.
5,614,937	A	3/1997	Nelson	6,970,506	B2	11/2005	Kim et al.
5,627,580	A	5/1997	Nelson	7,003,174	B2	2/2006	Kryukov et al.
5,627,937	A	5/1997	Kim	7,049,074	B2	5/2006	Schwartz
5,648,801	A	7/1997	Beardsley et al.	7,075,993	B2	7/2006	O'Brien
5,653,234	A	8/1997	Kim et al.	7,087,021	B2	8/2006	Paternostro
5,694,492	A	12/1997	Kim	7,110,601	B2	9/2006	Yanagisawa
5,717,463	A	2/1998	Brailean et al.	7,133,451	B2	11/2006	Kim et al.
5,774,593	A	6/1998	Zick	7,139,425	B2	11/2006	Takahashi
5,787,203	A	7/1998	Lee et al.	7,164,717	B2	1/2007	Katsavounidis
5,790,195	A	8/1998	Ohsawa	7,184,071	B2	2/2007	Chellappa et al.
5,796,864	A	8/1998	Callahan	7,221,706	B2	5/2007	Zhao et al.
5,799,111	A	8/1998	Guissin	7,221,805	B1	5/2007	Bachelder
5,828,776	A	10/1998	Lee et al.	7,526,142	B2	4/2009	Sheraizin et al.
5,838,835	A	11/1998	Martens	7,639,892	B2	12/2009	Sheraizin
5,844,607	A	12/1998	Gebler et al.	7,742,108	B2	6/2010	Sheraizin et al.
5,844,614	A	12/1998	Chong et al.	2001/0003545	A1	6/2001	Hong
5,845,012	A	12/1998	Jung	2002/0015508	A1	2/2002	Hannigan et al.
5,847,766	A	12/1998	Peak	2002/0104854	A1	8/2002	Lan
5,847,772	A	12/1998	Wells	2002/0122494	A1	9/2002	Sheraizin
5,850,294	A	12/1998	Apostolopoulos et al.	2002/0181598	A1	12/2002	Vetro et al.
5,852,475	A	12/1998	Gupta et al.	2003/0107681	A1	6/2003	Masayuki et al.
5,870,501	A	2/1999	Kim	2003/0122969	A1	7/2003	Higuchi
5,881,174	A	3/1999	Kim	2003/0152283	A1	8/2003	Kagumi
5,883,983	A	3/1999	Lee et al.	2004/0091145	A1	5/2004	Kohashi
5,901,178	A	5/1999	Lee et al.	2004/0184673	A1	9/2004	Watanabe
5,914,748	A	6/1999	Parulski	2004/0190789	A1	9/2004	Liu et al.
5,974,159	A	10/1999	Lubin et al.	2005/0013485	A1	1/2005	Masaki
5,982,926	A	11/1999	Kuo et al.	2005/0259185	A1	11/2005	Kim et al.
5,991,464	A	11/1999	Hsu et al.	2006/0013503	A1	1/2006	Kim
5,995,656	A	11/1999	Kim	2009/0161754	A1	6/2009	Sheraizin et al.
6,005,626	A	12/1999	Ding				
6,014,172	A	1/2000	Niesen				
6,037,986	A	3/2000	Gouliardon et al.				
6,055,340	A	4/2000	Nagao				
6,094,511	A	7/2000	Metcalfe et al.				
6,097,848	A	8/2000	Salvati				
6,100,625	A	8/2000	Yamamoto				
6,130,723	A	10/2000	Medin				
6,191,772	B1	2/2001	Mical et al.				
6,229,925	B1	5/2001	Alexandre et al.				
6,236,751	B1	5/2001	Farrell				

FOREIGN PATENT DOCUMENTS

EP	0729117	8/1996
GB	1503612	3/1978
JP	55-71363	5/1980
JP	6-133221	7/1985
JP	01206775	8/1989
JP	4-83480	3/1992
JP	08-191440	7/1996
WO	WO00/19726	4/2000

OTHER PUBLICATIONS

- “Non Final Office Action”, U.S. Appl. No. 10/898,557, (Jun. 8, 2010), 5 pages.
- “Notice of Allowability”, U.S. Appl. No. 12/316,168, (Jun. 29, 2010), 7 pages.
- “Non Final Office Action”, U.S. Appl. No. 12/316,168, (Jun. 24, 2009), 11 pages.
- “Non Final Office Action”, U.S. Appl. No. 10/898,557, (Jul. 8, 2009), 6 pages.
- “Notice of Allowance/Base Issue Fee”, U.S. Appl. No. 11/027,674, (Jul. 23, 2009), 6 pages.
- “Notice of Allowance”, U.S. Appl. No. 11/027,674, (Feb. 24, 2009), 16 pages.
- “Restriction Requirement”, U.S. Appl. No. 10/851,190, (May 19, 2009), 8 pages.
- “Notice of Allowance”, U.S. Appl. No. 10/898,557, (Jan. 27, 2010), 6 pages.
- “Notice of Allowance”, U.S. Appl. No. 12/316,168, (Jan. 29, 2010), 8 pages.
- “Notice of Allowance”, U.S. Appl. No. 10/851,190, (Feb. 8, 2010), 4 pages.
- “Non Final Office Action”, U.S. Appl. No. 10/851,190, (Sep. 1, 2009), 8 pages.
- Banhom, et al., “Digital Image Restoration”, *IEEE Signal Proc.*, (Mar. 1997), 24–41.
- Belkacem–Boussaid, “A New Image Smoothing Method Based on a Simple Model of Spatial Processing in the Early Stages of Human Vision”, *IEEE Trans. on Image Proc.*, vol. 9, No. 2, (Feb. 2000), 220–226.
- Chan, “A practical postprocessing technique for real-time block-based coding system”, *IEEE trans on circuits and systems for video technology*, vol. 8, No. 1 (Feb. 1998), 4–8.
- Liu, et al., “A new postprocessing technique for the block based DCT coding based on the convex–projection theory”, *IEEE trans on consumer electronics*, vol. 4, No. 3, (Aug. 1998), 1054–1061.
- Lee, et al., “Efficient algorithm and architecture for post processor in HDTV”, *IEEE trans on consumer electronics*, vol. 44, No. 1, (Feb. 1998), 16–26.
- Choung, et al., “A fast adaptive image restoration filter for reducing block artifact in compressed images”, *IEEE trans on consumer electronics*, vol. 44, No. 1, (Nov. 1997), 1340–1346.
- Jeon, B et al., “Blocking artifacts reduction in image compression with block boundary discontinuity criterion”, *IEEE trans on circuits and systems for video technology*, vol. 8, No. 3, (Jun. 1998), 345–357.
- Zhong, et al., “Derivation of prediction equation for blocking effect reduction”, *IEEE trans on circuits and systems for video technology*, vol. 9, No. 3, (Apr. 1999), 415–418.
- Meier, et al., “Reduction of blocking artifacts in image and video coding”, *IEEE trans on circuits and systems for video technology*, (Apr. 1999), 490–500.
- Kim, et al., “An advanced contrast enhancement using partially overlapped sub-block histogram equalization”, *IEEE Trans on circuits and systems for video technology*, vol. 11, No. 4, (Apr. 2001), 475–484.
- Stark, Alex J., “Adaptive image contrast enhancement Enhancement using generalizations of histogram equalization”, *IEEE trans on image processing*, vol. 9, No. 5, (May 2000), 889–896.
- Hier, et al., “Real time locally adaptive contrast enhancement; A practical key to overcoming display and human visual system limitation”, *SID digest*, (1993), 491–493.
- Chang, Dah–Chung “Image contrast enhancement based on local standard deviation”, *IEEE trans on medical imaging*, vol. 17, No. 4, (Aug. 1998), 518–531.
- Kim, Yeong T., “Contrast enhancement using brightness preserving bi-histogram equalization”, *IEEE trans on consumer electronics*, vol. 43, No. 1, (Feb. 1997), 1–8.
- Kim, Tae K., et al., “Contrast enhancement system using spatially adaptive histogram equalization with temporal filtering”, *IEEE trans on consumer electronics*, vol. 44, No. 1, (Feb. 1998), 82–87.
- Sakaue, Shigeo et al., “Adaptive gamma processing of the video camera for expansion of the dynamic range”, *IEEE trans on consumer electronics*, vol. 41, No. 3, (Aug. 1995), 555–582.
- Russ, John C., “The image processing handbook”, *CRS press Inc.*, (1995), 674.
- Talluri, Raj et al., “A Robust, Scalable, Object–Based Video Compression Technique for Very Low Bit–Rate Coding”, *IEEE Transaction of Circuit and Systems for Video Technology*, (Feb. 1997), vol. 7, No. 1.
- Awadkh, Al–Asmari “An Adaptive Hybrid Coding Scheme for HDTV and Digital Sequences”, *IEEE Transacitons on Consumer Electronics*, vol. 42, No. 3, (Aug. 1995), 926–936.
- Kwok, Tung Lo “Predictive Mean Search Algorithms for Fast VQ Encoding of Images”, *IEEE Transactions On Consumer Electronics*, vol. 41, No. 2, (May 1995), 327–331.
- Goel, James et al., “Pre–processing for MPEG Compression Using Adaptive Spatial Filtering”, *IEEE Transactions On Consumer electronics*, vol. 41, No. 3, (Aug. 1995), 687–698.
- Feng, Jian et al., “Motion Adaptive Classified Vector Quantization for ATM Video Coding”, *IEEE Transactions on Consumer Electronics*, vol. 41, No. 2, (May 1995), 322–326.
- Lan, Austin Y., et al., “Scene–Context Dependent Reference–Frame Placement for MPEG Video Coding”, *IEEE Transactions on Circuits and Systems for Video Technology*, vol. 9, No. 3, (Apr. 1999), 478–489.
- Fan, Kuo–Chin et al., “An Active Scene Analysis–Based approach for Pseudo constant Bit–Rate Video Coding”, *IEEE Transactions on Circuits and Systems for Video Technology*, vol. 8, No. 2, (Apr. 1998), 159–170.
- Takashi, Ida et al., “Image Segmentation and Contour Detection Using Fractal Coding”, *IEEE Transitions on Circuits and Systems for Video Technology*, vol. 8, No. 8, (Dec. 1998), 968–975.
- Liang, Shen “A Segmentation–Based Lossless Image Coding Method for High–Resolution Medical Image Compression”, *IEEE Transactions on Medical Imaging*, vol. 16, No. 3, (Jun. 1997), 301–316.
- Munteanu, Adrian et al., “Wavelet–Based Lossless Compression of Coronary Angiographic Images”, *IEEE Transactions on Medical Imaging*, vol. 18, No. 3, (Mar. 1999), 272–281.
- Okumura, Akira et al., “Signal Analysis and Compression performance Evaluation of Pathological Microscopic Images”, *IEEE Transactions on Medical Imaging*, vol. 16, No. 6, (Dec. 1997), 701–710.
- Pappas, et al., “Digital Color Restoration of Old Paintings”, *IEEE Trans. on Image Proc.*, vol. 9, No. 2, (Feb. 2000), 291–294.
- Kim, et al., “Impact of HVS Models on Model–based Half-toning”, *IEEE Trans. on Image Proc.*, vol. 11, No. 3, (Mar. 2002), 258–269.

- Hentschel, et al., "Effective Paking Filter and is Implementation on a Programmable Architecture", *IEEE Trans. on Consumer Electronics*, vol. 47, No. 1,(Feb. 2001),33–39.
- Yang, et al., "Maximum–Likelihood Parameter Estimation for Image Ringing–Artifact Removal", *IEEE Trans. on Ciccuits and Systems for Video Technology*, vol. 11, No. 8,(Aug. 2001),963–973.
- Immerkaer, "Use of Blur–Space of Deblurring and Edge–Preserving Noise Smoothing", *IEEE Trans On Image Proc.*, vol. 10, No. 6,(Jun. 2001),837–840.
- Chan, et al., "The Digital TV Filter and Nonlinear Denoising", *IEEE Trans on Image Proc.*, vol. 10, No. 2,(Feb. 2001), 231–241.
- Liu, et al., "Complexity– Regularized Image Denoising", *IEEE Trans on Image Processing*, vol. 10, No. 6,(Jun. 2001), 341–351.
- Jostschulte, et al., "Perception Adaptive Temporal TV–noise Reduction Using Contour Preserving Prefilter Techniques", *IEEE on Consumer Electronics*, vol. 44, No. 3,(Aug. 1998), 1091–1096.
- Brice, Richard "Multimedia and Virtual Reality Engineering", (1997),1–8, 174–175, 280–283.
- Conway, Lynn et al., "Video mirroring and Iconic Gestures: Enhancing Basic Videophones to Provide Visual Coaching and Visual Control", *IEEE Transactions on Consumer Electronics*, vol. 44, No. 2,(May 1998),388–397.
- Cheol, Hong M., et al., "A new adaptive quantization method to reduce blocking effect", *IEEE transaction on consumer electronics*, vol. 44, No. 3,(Aug. 1998),768–772.
- Massimo, Mancuso et al., "Advanced pre/ post processing for DCT coded images", *IEEE transactions on consumer electronics*, vol. 44, No. 3,(Aug. 1998),1039–1041.
- Tao, Chen "Adaptive postfiltering of transform coefficients for the reduction of blocking artifacts", *IEEE transactions on circuits and systems for video technology*, vol. 11, No. 5,(May 2001),594–602.
- Polesel, Andrea et al., "Image Enhancement Via Adaptive Unsharp Masking", *IEEE transactions on image processing*, vol. 9, No. 3,(Mar. 2000),505–510.
- Olukayode, A et al., "An algorithm for integrated noise reduction and sharpness enhancement", *IEEE Transactions on Consumer Electronics*, vol. 46, No. 3,(Aug. 2000),474–480.
- Sung–Hoon, Hong, "Joint video coding of MPEG–2 video programs for digital broadcasting services", *IEEE transactions on broadcasting*, vol. 44, No. 2,(Jun. 1998),153–164.
- Lim, Jae "Two dimensional signal and image processing", *USA Simon & Schuster*, (1990),430.
- Sherazain, et al., "U.S. Appl. No. 09/524,618", filed Mar. 14, 2000.
- Leonard, Eugene "Considerations regarding the use of digital data to generate video backgrounds", *SMPTE journal*, vol. 87,(Aug. 1987),499–504.
- Tescher, Andrew "Multimedia is the message", *IEEE signal processing magazine*, vol. 16, No. 1,(Jan. 1999),44–54.
- Mancuso, et al., "A new post–processing algorithm to reduce artifacts in block coded images", *IEEE trans on consumer electronics*, vol. 43, No. 3,(Aug. 1997),303–307.
- Yang, J et al., "Noise estimation for blocking artifacts reduction in DCT coded images", *IEEE trans on circuits and systems for video tech nology*, vol. 10, No. 7,(Oct. 2000),1116–1120.
- Kuo, et al., "Adaptive postprocessor for block endoded images", *IEEE trans on circuits and systems for video technology*, vol. 5, No. 4,(Aug. 1995),298–304.
- Min, et al., "A new adaptive quantization method to reduce blocking effect", *IEEE Trans on consumer electronics*, vol. 44, No. 3,(Aug. 1998),768–772.

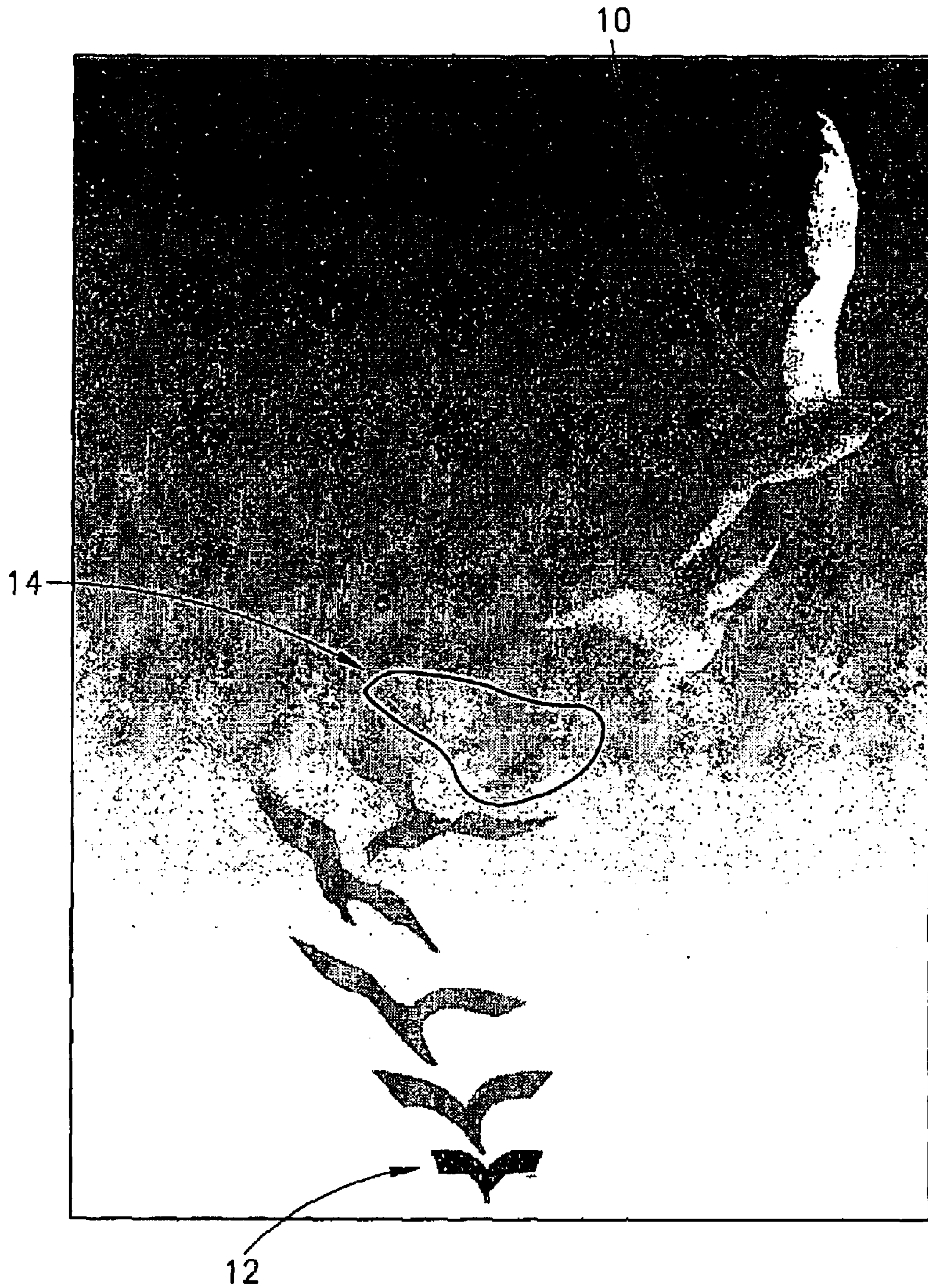

FIG.1

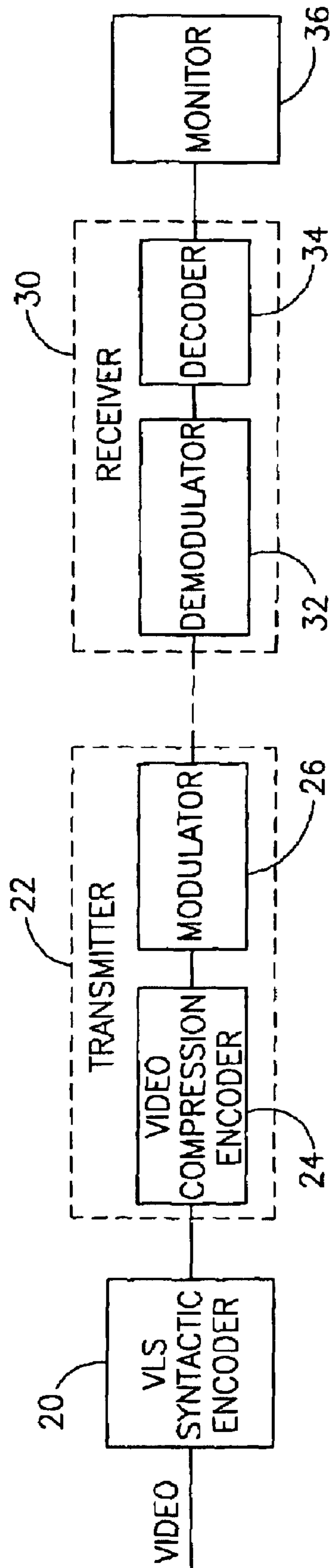

FIG. 2

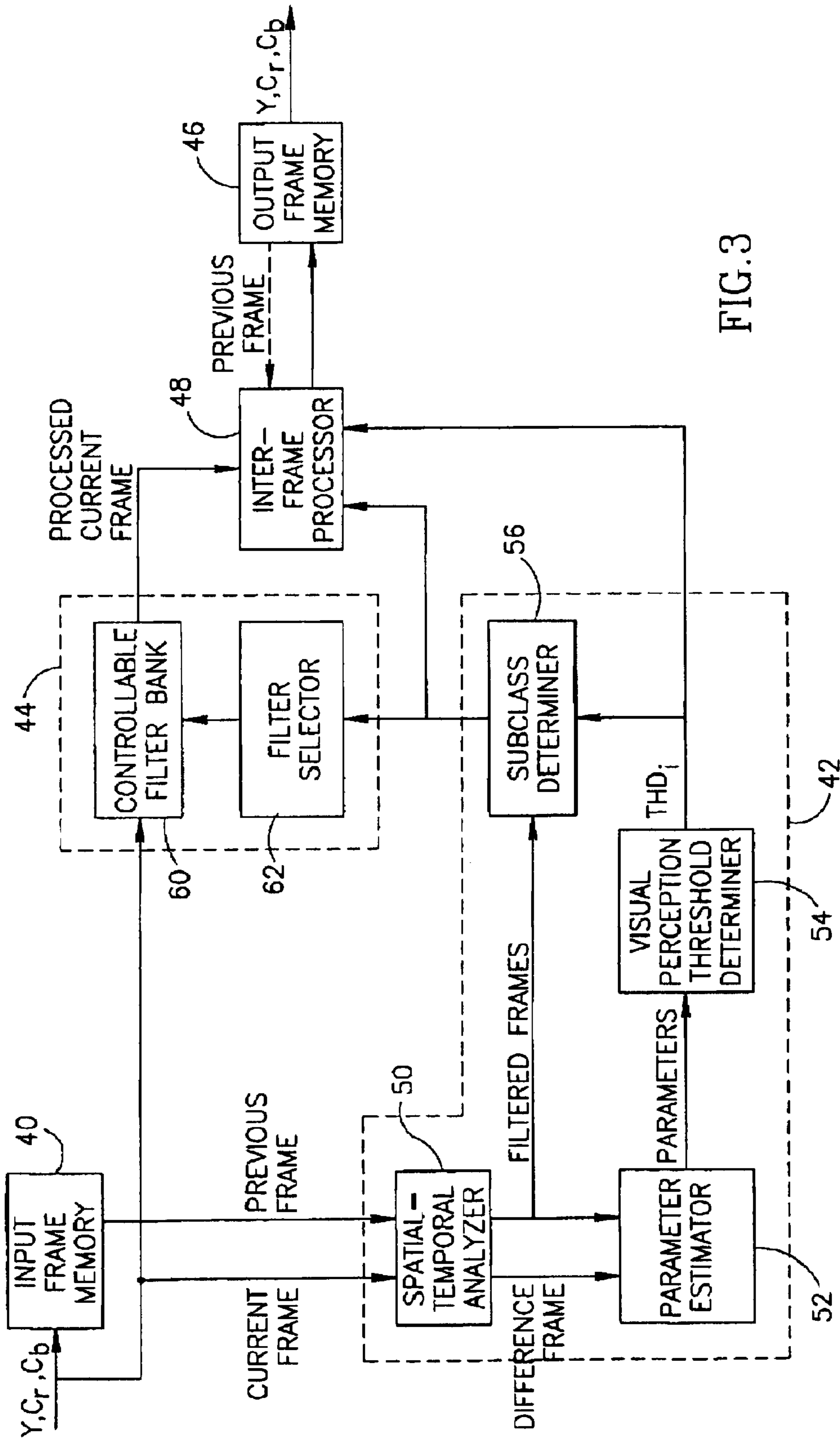

FIG. 3

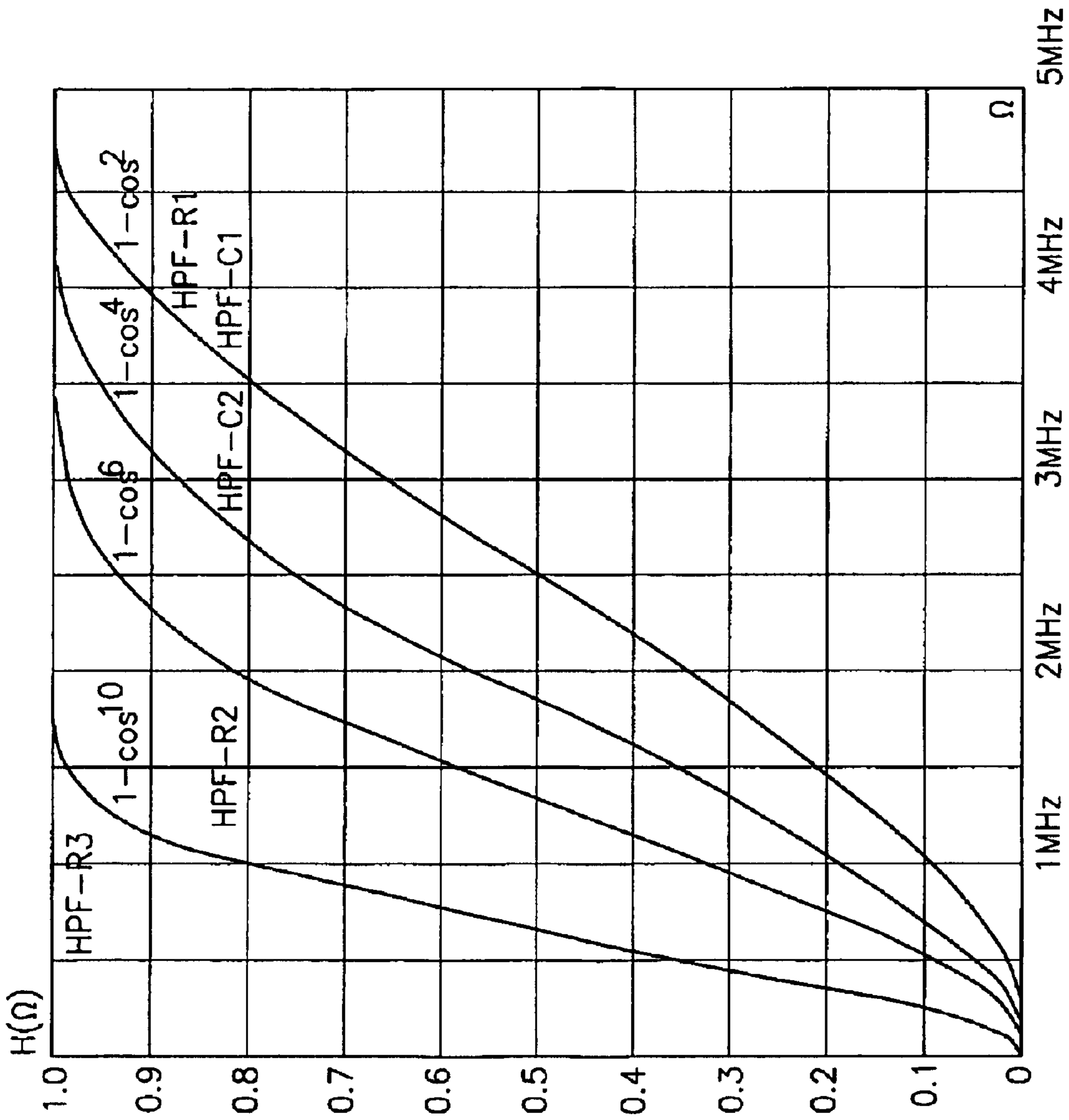

FIG.4

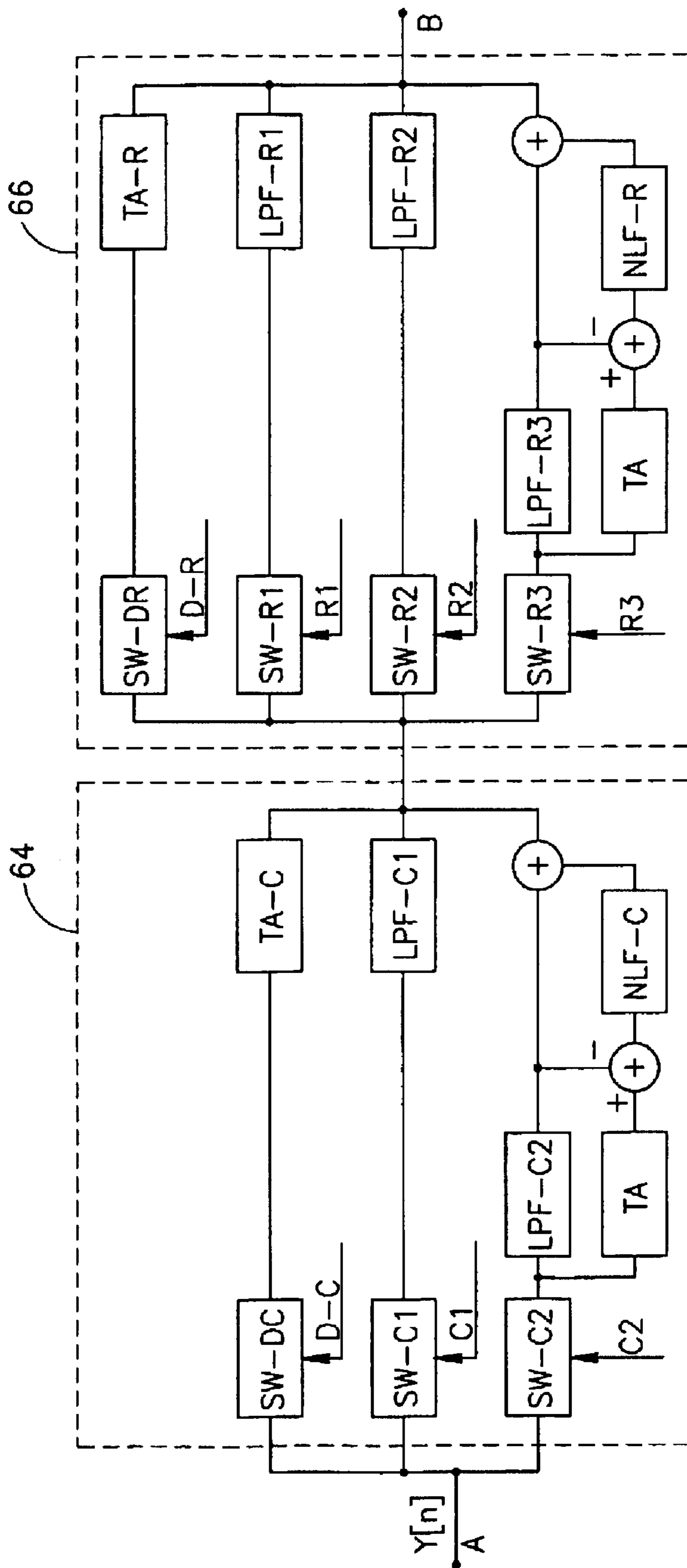

FIG. 5A

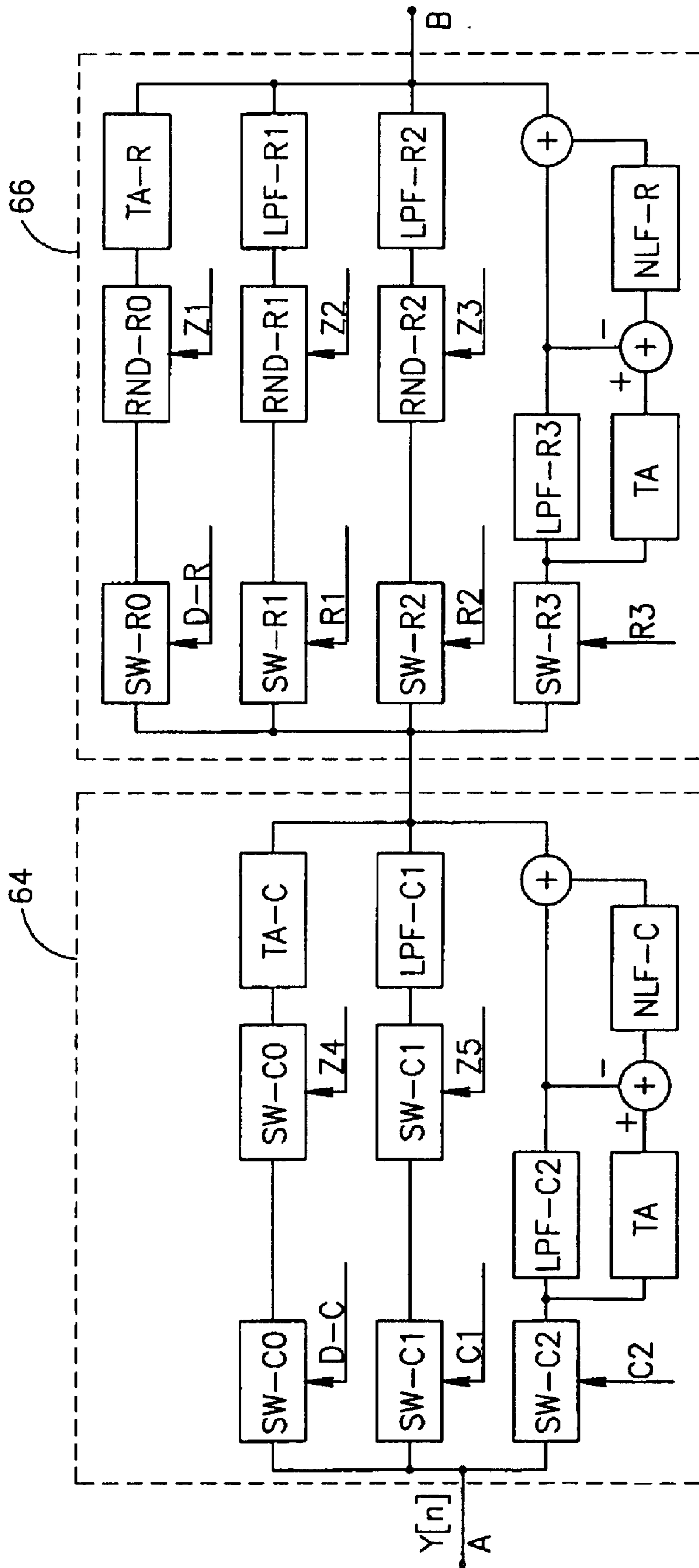

FIG. 5B

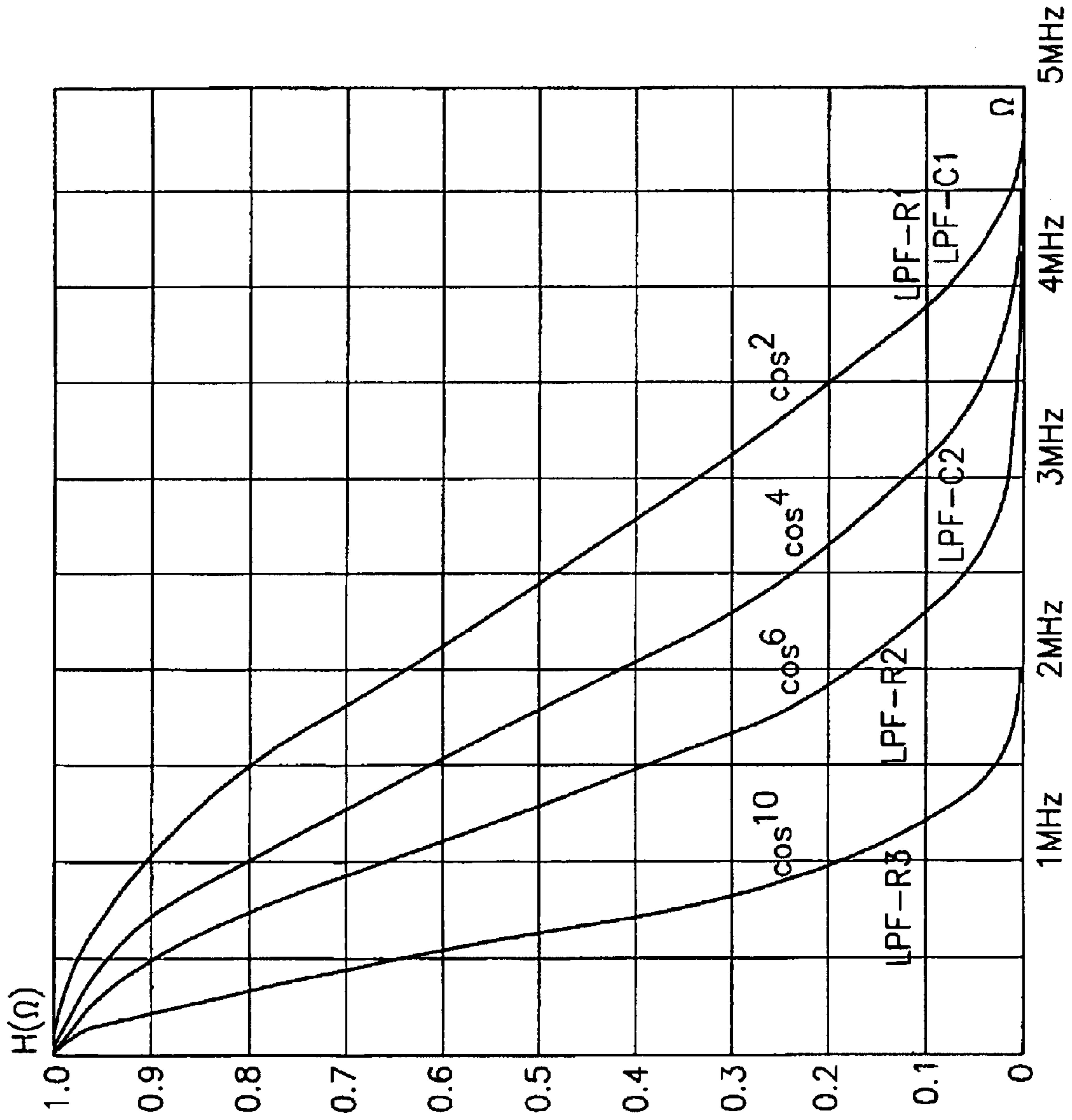

FIG. 6

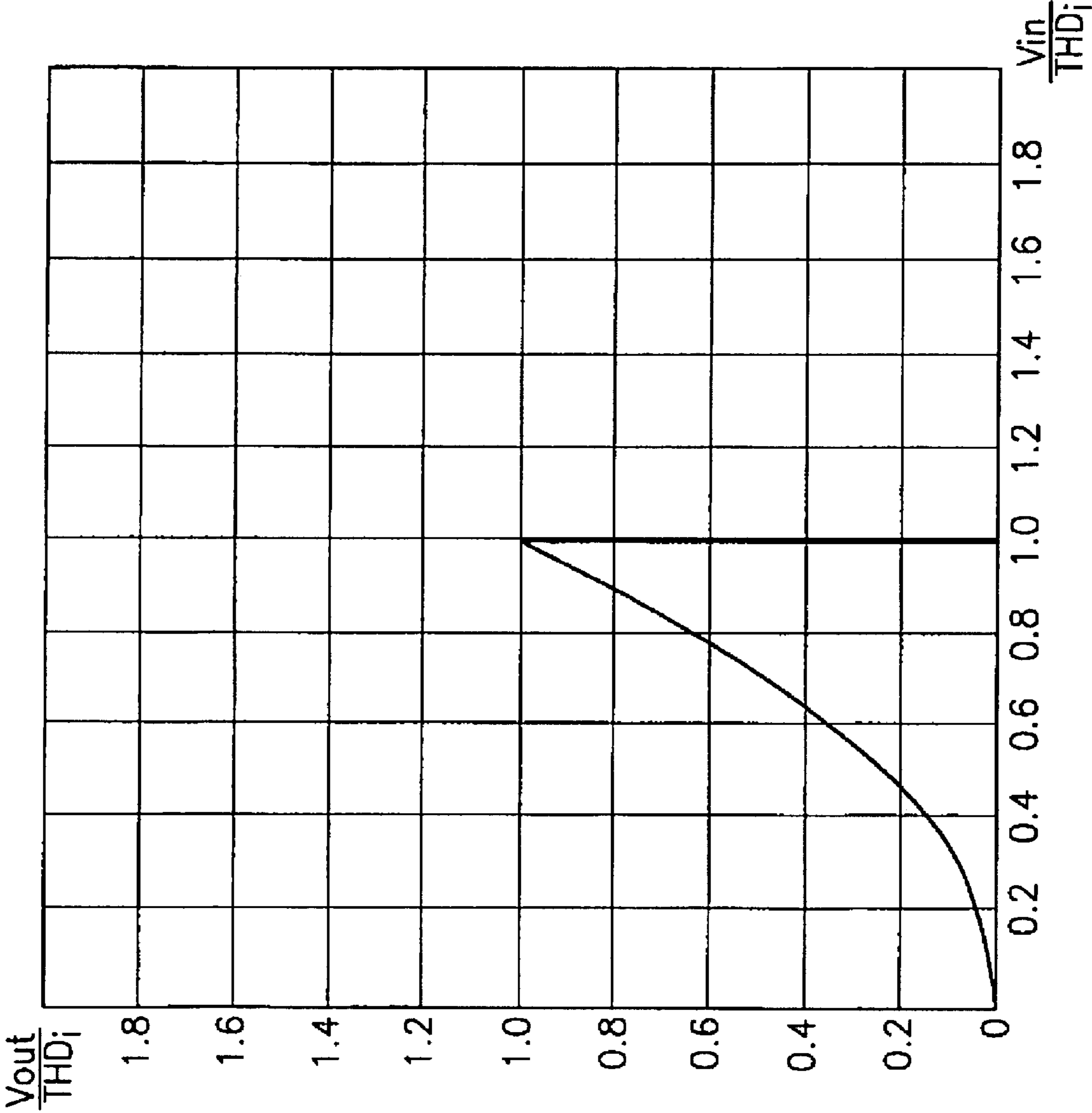

FIG. 7

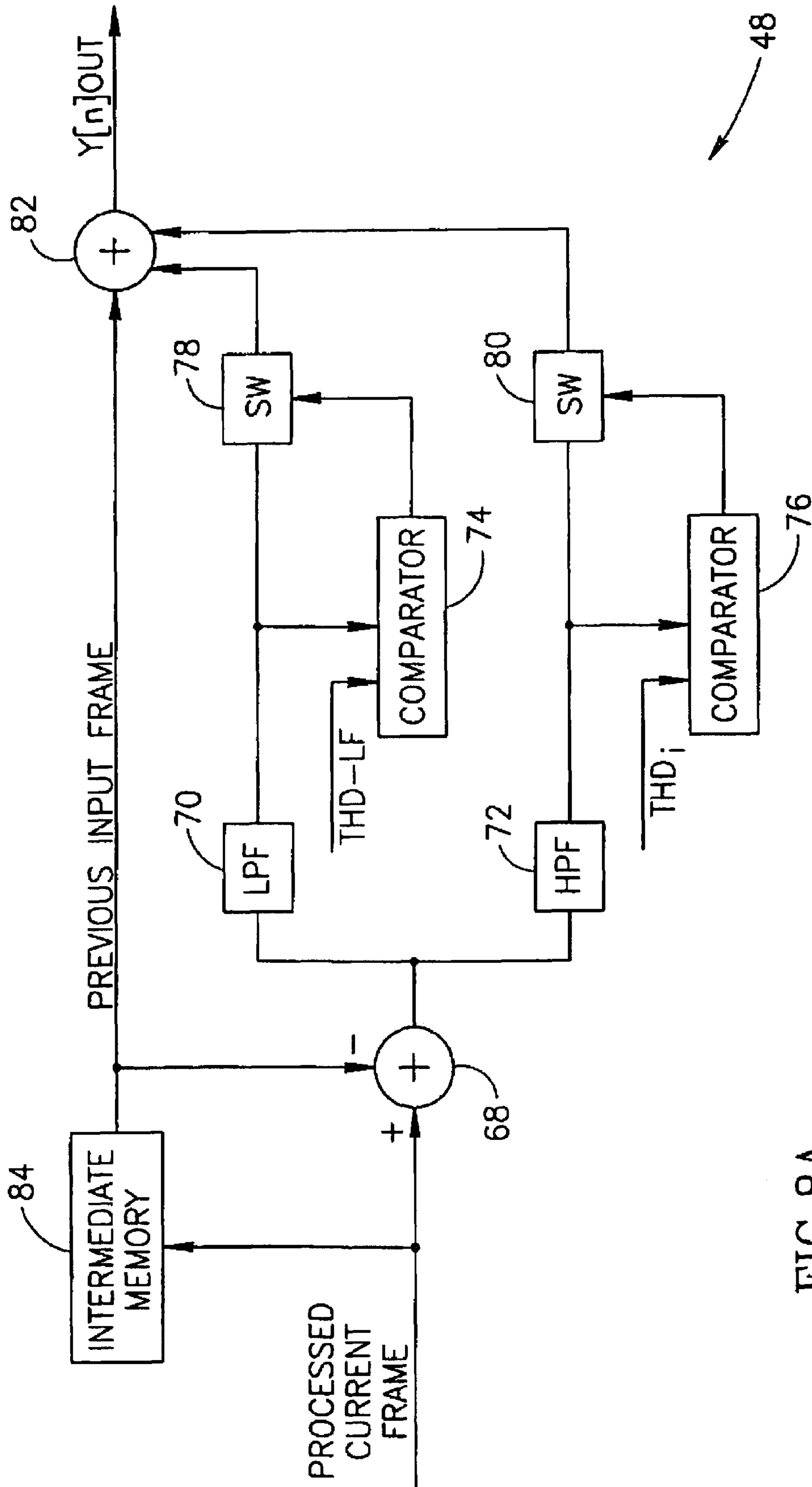

FIG. 8A

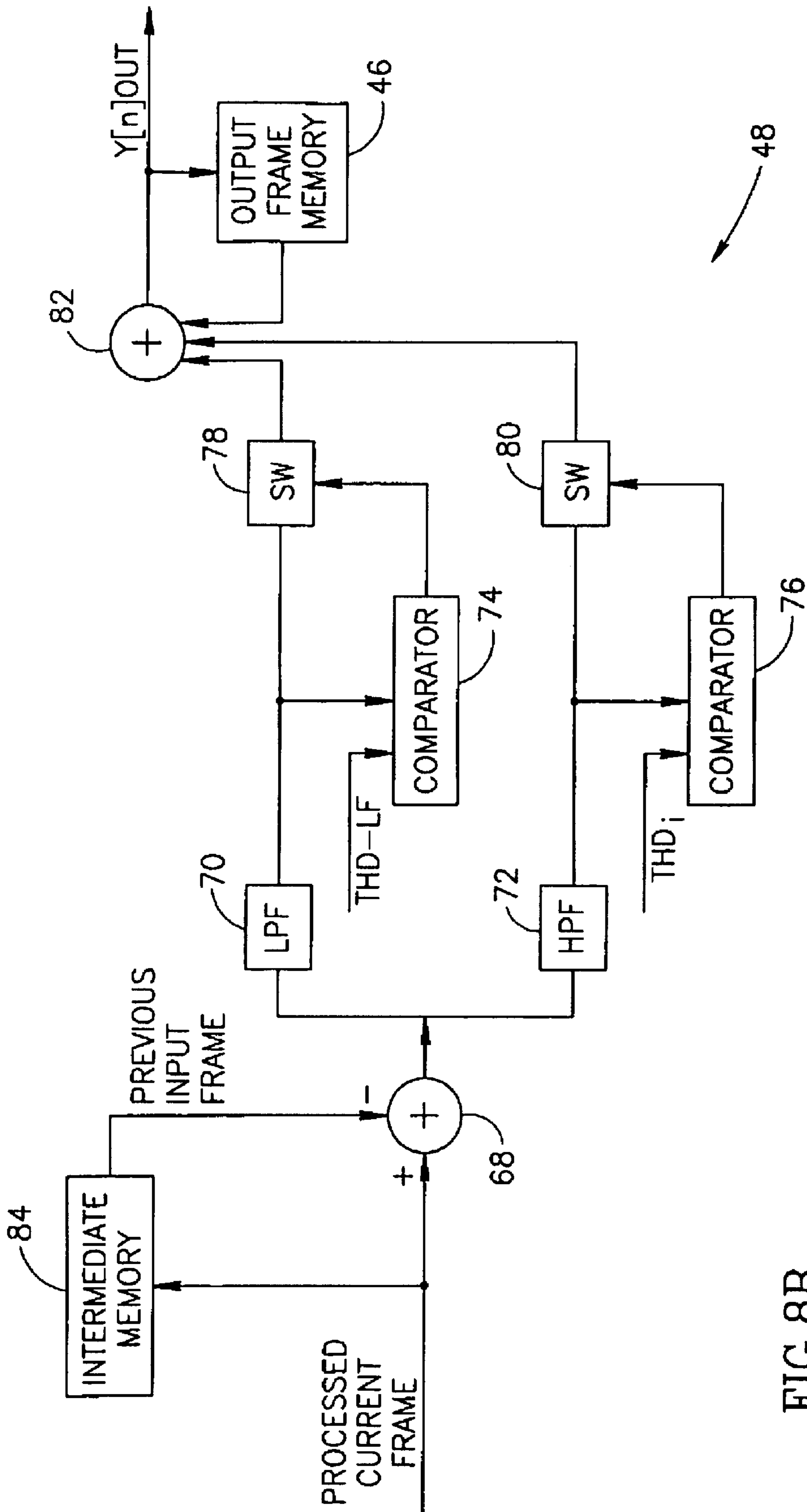

FIG. 8B

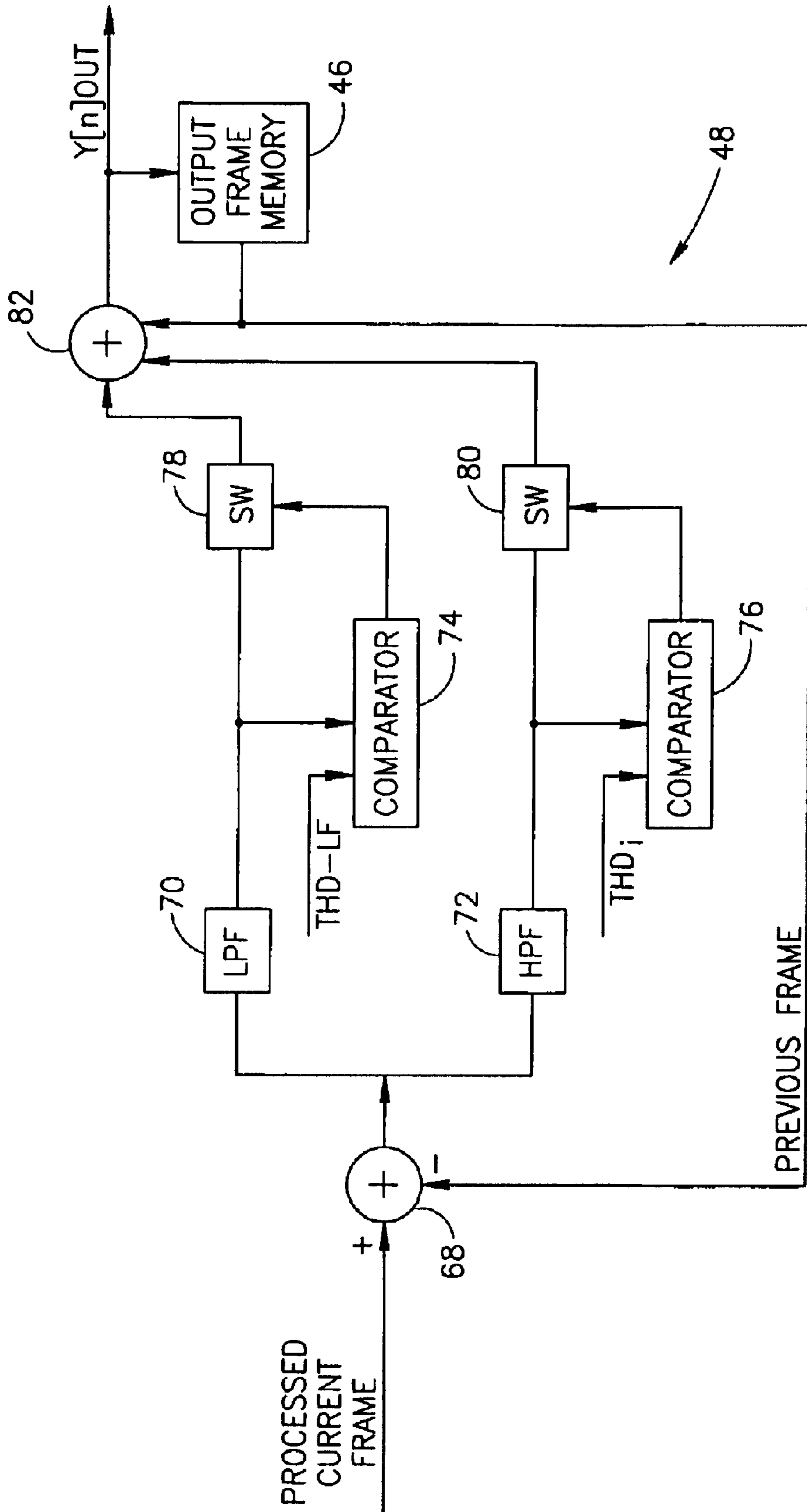

FIG. 8C

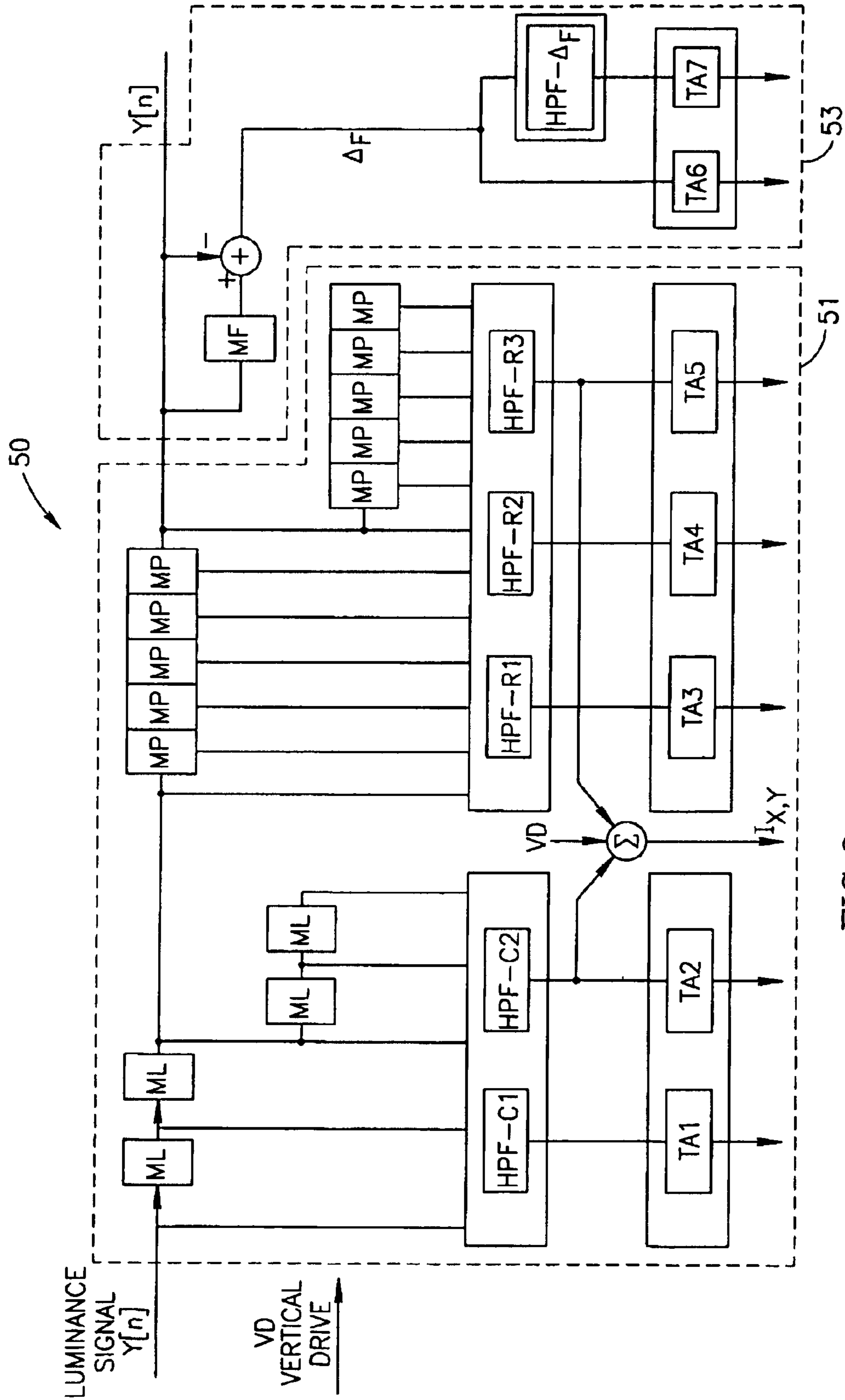

FIG. 9

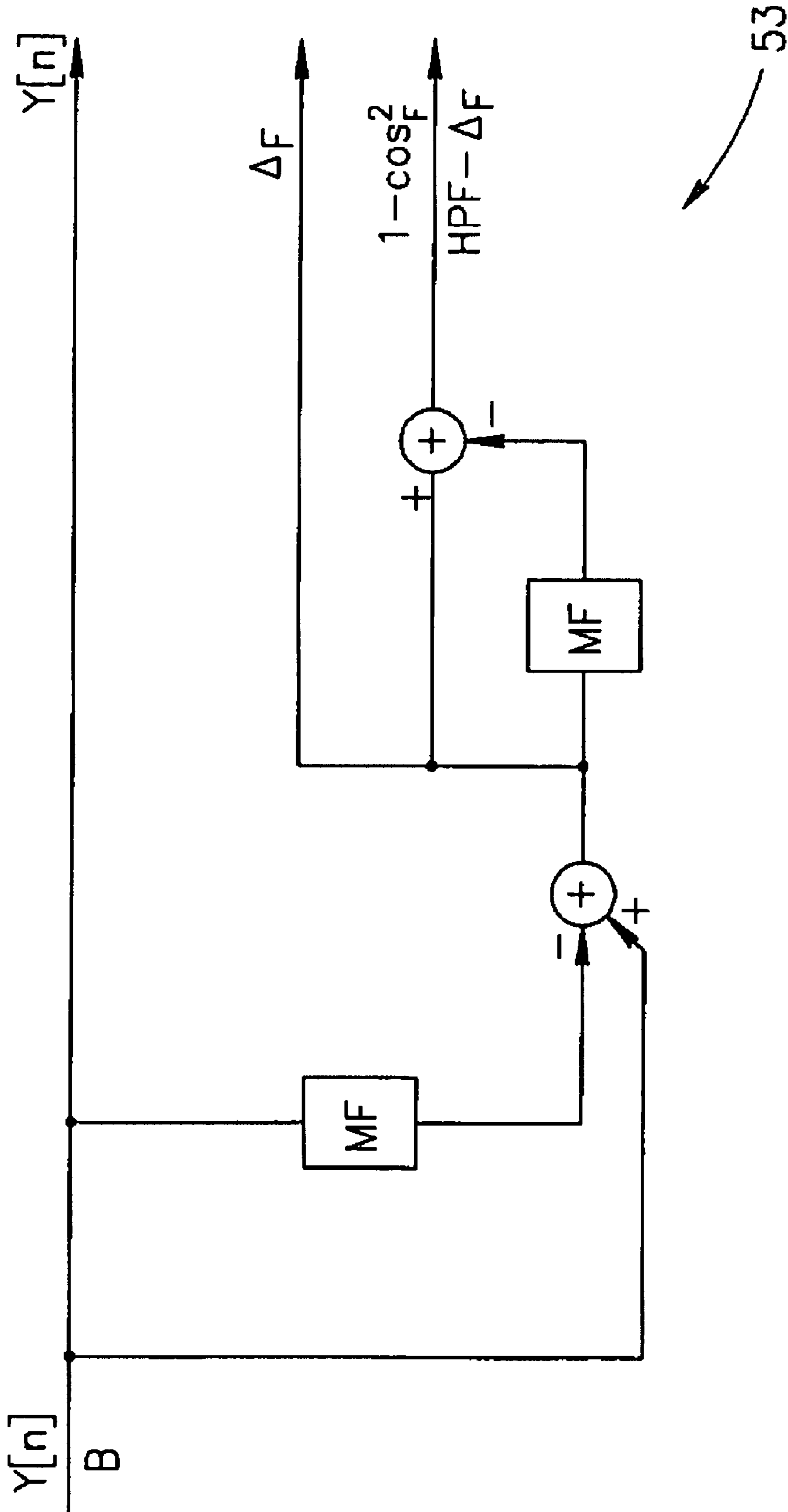
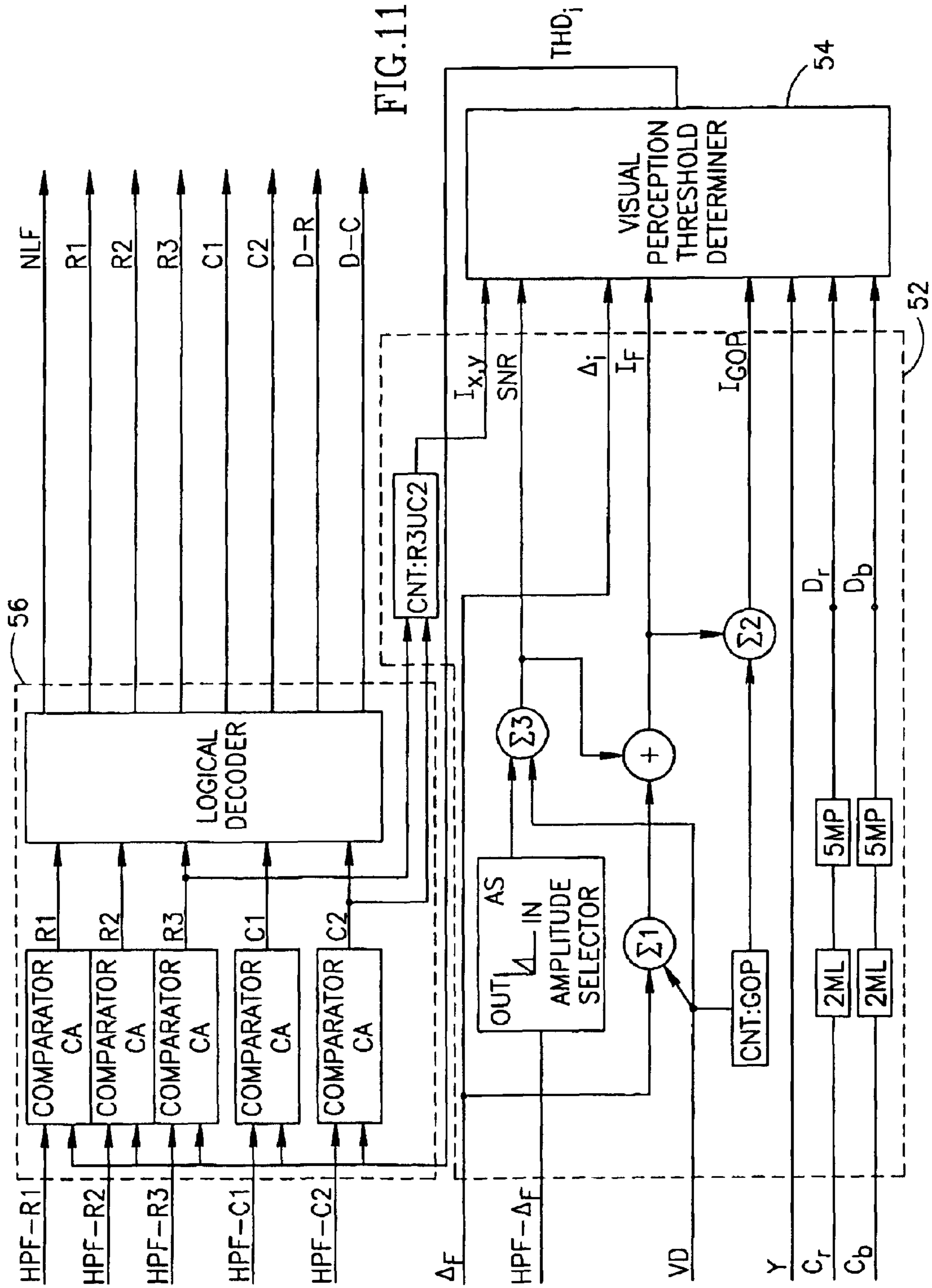

FIG. 10B



METHOD AND APPARATUS FOR VISUAL LOSSLESS IMAGE SYNTACTIC ENCODING

Matter enclosed in heavy brackets [] appears in the original patent but forms no part of this reissue specification; matter printed in italics indicates the additions made by reissue.

CROSS-REFERENCE TO RELATED APPLICATIONS

This application is a continuation application of U.S. Ser. No. 10/121,685, filed Apr. 15, 2002, now U.S. Pat. No. 6,952,500, which is a continuation application of U.S. Ser. No. 09/524,618, filed Mar. 14, 2000, issued as U.S. Pat. No. 6,473,532, which patents are incorporated herein by reference.

FIELD OF THE INVENTION

The present invention relates generally to processing of video images and, in particular, to syntactic encoding of images for later compression by standard compression techniques.

BACKGROUND OF THE INVENTION

There are many types of video signals, such as digital broadcast television (TV), video conferencing, interactive TV, etc. All of these signals, in their digital form, are divided into frames, each of which consists of many pixels (image elements), each of which requires 8–24 bits to describe them. The result is megabits of data per frame.

Before storing and/or transmitting these signals, they typically are compressed, using one of many standard video compression techniques, such as JPEG, MPEG, H-compression, etc. These compression standards use video signal transforms and intra- and inter-frame coding which exploit spatial and temporal correlations among pixels of a frame and across frames.

However, these compression techniques create a number of well-known, undesirable and unacceptable artifacts, such as blockiness, low resolution and wiggles, among others. These are particularly problematic for broadcast TV (satellite TV, cable TV, etc.) or for systems with very low bit rates (video conferencing, videophone).

Much research has been performed to try and improve the standard compression techniques. The following patents and articles discuss various prior art methods to do so:

U.S. Pat. Nos. 5,870,501, 5,847,766, 5,845,012, 5,796,864, 5,774,593, 5,586,200, 5,491,519, 5,341,442;

Raj Talluri et al, "A Robust, Scalable, Object-Based Video Compression Technique for Very Low Bit-Rate Coding," IEEE Transactions of Circuit and Systems for Video Technology, vol. 7, No. 1, February 1997;

AwadKh. Al-Asmari, "An Adaptive Hybrid Coding Scheme for HDTV and Digital Sequences," IEEE Transactions on Consumer Electronics, vol. 42, No. 3, pp. 926–936, August 1995;

Kwok-tung Lo and Jian Feng, "Predictive Mean Search Algorithms for Fast VQ Encoding of Images," IEEE Transactions On Consumer Electronics, vol. 41, No. 2, pp. 327–331, May 1995;

James Goel et al. "Pre-processing for MPEG Compression Using Adaptive Spatial Filtering," IEEE Transactions On Consumer Electronics, vol. 41, No. 3, pp. 687–698, August 1995;

Jian Feng et al. "Motion Adaptive Classified Vector Quantization for ATM Video Coding", IEEE Transactions on Consumer Electronics, vol. 41, No. 2, p. 322–326, May 1995;

Austin Y. Lan et al., "Scene-Context Dependent Reference—Frame Placement for MPEG Video Coding," IEEE Transactions on Circuits and Systems for Video Technology, vol. 9, No.3, pp. 478–489, April 1999;

Kuo-Chin Fan, Kou-Sou Kan, "An Active Scene Analysis-Based approach for Pseudoconstant Bit-Rate Video Coding", IEEE Transactions on Circuits and Systems for Video Technology, vol. 8 No.2, pp. 159–170, April 1998;

Takashi Ida and Yoko Sambansugi, "Image Segmentation and Contour Detection Using Fractal Coding", IEEE Transactions on Circuits and Systems for Video Technology, vol. 8, No. 8, pp. 968–975, December 1998;

Liang Shen and Rangaraj M. Rangayyan, "A Segmentation-Based Lossless Image Coding Method for High-Resolution Medical Image Compression," IEEE Transactions on Medical Imaging, vol. 16, No. 3, pp. 301–316, June 1997;

Adrian Munteanu et al., "Wavelet-Based Lossless Compression of Coronary Angiographic Images", IEEE Transactions on Medical Imaging, vol. 18, No. 3, p. 272–281, March 1999; and

Akira Okumura et al., "Signal Analysis and Compression Performance Evaluation of Pathological Microscopic Images," IEEE Transactions on Medical Imaging, vol. 16, No. 6, pp. 701–710, December 1997.

SUMMARY OF THE INVENTION

An object of the present invention is to provide a method and apparatus for video compression which is generally lossless vis-à-vis what the human eye perceives.

There is therefore provided, in accordance with a preferred embodiment of the present invention, a visual perception threshold unit for image processing. The threshold unit identifies a plurality of visual perception threshold levels to be associated with the pixels of a video frame, wherein the threshold levels define contrast levels above which a human eye can distinguish a pixel from among its neighboring pixels of the video frame.

There is also provided, in accordance with a preferred embodiment of the present invention, the visual perception threshold unit which includes a parameter generator and a threshold generator. The parameter generator generates a multiplicity of parameters that describe at least some of the information content of the processed frame. From the parameters, the threshold generator generates a plurality of visual perception threshold levels to be associated with the pixels of the video frame. The threshold levels define contrast levels above which a human eye can distinguish a pixel from among its neighboring pixels of the frame.

Moreover, in accordance with a preferred embodiment of the present invention, the parameter generator includes a volume unit, a color unit, an intensity unit or some combination of the three. The volume unit determines the volume of information in the frame, the color unit determines the per pixel color and the intensity unit determines a cross-frame change of intensity.

There is also provided, in accordance with a preferred embodiment of the present invention, a method for generating visual perception thresholds. The method includes analysis of the details of the frames of a video signal, estimating the parameters of the details, and defining a visual

perception threshold for each detail in accordance with the estimated detail parameters.

There is also provided, in accordance with a preferred embodiment of the present invention, a method for describing images. The method includes determining which details in the image can be distinguished by the human eye and which ones can only be detected by it.

Moreover, in accordance with a preferred embodiment of the present invention, the method also includes providing one bit to describe a pixel which can only be detected by the human eye, and providing three bits to describe a pixel which can be distinguished by the human eye.

Further, in accordance with a preferred embodiment of the present invention, the method also includes smoothing the data of less-distinguished details.

Finally, in accordance with a preferred embodiment of the present invention, the step of determining details also includes identifying areas of high contrast and areas whose details have small dimensions.

BRIEF DESCRIPTION OF THE DRAWINGS

The present invention will be understood and appreciated more fully from the following detailed description taken in conjunction with the appended drawings in which:

FIG. 1 is an example of a video frame;

FIG. 2 is a block diagram illustration of a video compression system having a visual lossless syntactic encoder, constructed and operative in accordance with a preferred embodiment of the present invention;

FIG. 3 is a block diagram illustration of the details of the visual lossless syntactic encoder of FIG. 2;

FIG. 4 is a graphical illustration of the transfer functions for a number of high pass filters useful in the syntactic encoder of FIG. 3;

FIGS. 5A and 5B are block diagram illustrations of alternative embodiments of a controllable filter bank forming part of the syntactic encoder of FIG. 3;

FIG. 6 is a graphical illustration of the transfer functions for a number of low pass filters useful in the controllable filter bank of FIGS. 5A and 5B;

FIG. 7 is a graphical illustration of the transfer function for a non-linear filter useful in the controllable filter bank of FIGS. 5A and 5B;

FIGS. 8A, 8B and 8C are block diagram illustrations of alternative embodiments of an inter-frame processor forming a controlled filter portion of the syntactic encoder of FIG. 3;

FIG. 9 is a block diagram illustration of a spatial-temporal analyzer forming part of the syntactic encoder of FIG. 3;

FIGS. 10A and 10B are detail illustrations of the analyzer of FIG. 9; and

FIG. 11 is a detail illustration of a frame analyzer forming part of the syntactic encoder of FIG. 3.

DETAILED DESCRIPTION OF THE PRESENT INVENTION

Applicants have realized that there are different levels of image detail in an image and that the human eye perceives these details in different ways. In particular, Applicants have realized the following:

1. Picture details whose detection mainly depends on the level of noise in the image occupy approximately 50–80% of an image.

2. A visual perception detection threshold for image details does not depend on the shape of the details in the image.

3. A visual perception threshold THD depends on a number of picture parameters, including the general brightness of the image. It does not depend on the noise spectrum.

The present invention is a method for describing, and then encoding, images based on which details in the image can be distinguished by the human eye and which ones can only be detected by it.

Reference is now made to FIG. 1, which is a grey-scale image of a plurality of shapes of a bird in flight, ranging from a photograph of one (labeled 10) to a very stylized version of one (labeled 12). The background of the image is very dark at the top of the image and very light at the bottom of the image.

The human eye can distinguish most of the birds of the image. However, there is at least one bird, labeled 14, which the eye can detect but cannot determine all of its relative contrast details. Furthermore, there are large swaths of the image (in the background) which have no details in them.

The present invention is a method and system for syntactic encoding of video frames before they are sent to a standard video compression unit. The present invention separates the details of a frame into two different types, those that can only be detected (for which only one bit will suffice to describe each of their pixels) and those which can be distinguished (for which at least three bits are needed to describe the intensity of each of their pixels).

Reference is now made to FIG. 2, which illustrates the present invention within an image transmission system. Thus, FIG. 2 shows a visual lossless syntactic (VLS) encoder 20 connected to a standard video transmitter 22 which includes a video compression encoder 24, such as a standard MPEG encoder, and a modulator 26. VLS encoder 20 transforms an incoming video signal such that video compression encoder 24 can compress the video signal two to five times more than video compression encoder 24 can do on its own, resulting in a significantly reduced volume bit stream to be transmitted.

Modulator 26 modulates the reduced volume bit stream and transmits it to a receiver 30, which, as in the prior art, includes a demodulator 32 and a decoder 34. Demodulator 32 demodulates the transmitted signal and decoder 34 decodes and decompresses the demodulated signal. The result is provided to a monitor 36 for display.

It will be appreciated that, although the compression ratios are high in the present invention, the resultant video displayed on monitor 36 is not visually degraded. This is because encoder 20 attempts to quantify each frame of the video signal according to which sections of the frame are more or less distinguished by the human eye. For the less-distinguished sections, encoder 20 either provides pixels of a minimum bit volume, thus reducing the overall bit volume of the frame or smoothes the data of the sections such that video compression encoder 24 will later significantly compress these sections, thus resulting in a smaller bit volume in the compressed frame. Since the human eye does not distinguish these sections, the reproduced frame is not perceived significantly differently than the original frame, despite its smaller bit volume.

Reference is now made to FIG. 3, which details the elements of VLS encoder 20. Encoder 20 comprises an input frame memory 40, a frame analyzer 42, an intra-frame processor 44, an output frame memory 46 and an inter-frame processor 48. Analyzer 42 analyzes each frame to separate it

5

into subclasses, where subclasses define areas whose pixels cannot be distinguished from each other. Intra-frame processor **44** spatially filters each pixel of the frame according to its subclass and, optionally, also provides each pixel of the frame with the appropriate number of bits. Inter-frame processor **48** provides temporal filtering (i.e. inter-frame filtering) and updates output frame memory **46** with the elements of the current frame which are different than those of the previous frame.

It is noted that frames are composed of pixels, each having luminance Y and two chrominance C_r and C_b components, each of which is typically defined by eight bits. VLS encoder **20** generally separately processes the three components. However, the bandwidth of the chrominance signals is half as wide as that of the luminance signal. Thus, the filters (in the x direction of the frame) for chrominance have a narrower bandwidth. The following discussion shows the filters for the luminance signal Y .

Frame analyzer **42** comprises a spatial-temporal analyzer **50**, a parameter estimator **52**, a visual perception threshold determiner **54** and a subclass determiner **56**. Details of these elements are provided in FIGS. **9–11**, discussed hereinbelow.

As discussed hereinabove, details which the human eye distinguishes are ones of high contrast and ones whose details have small dimensions. Areas of high contrast are areas with a lot of high frequency content. Thus, spatial-temporal analyzer **50** generates a plurality of filtered frames from the current frame, each filtered through a different high pass filter (HPF), where each high pass filter retains a different range of frequencies therein.

FIG. **4**, to which reference is now briefly made, is an amplitude vs. frequency graph illustrating the transfer functions of an exemplary set of high pass filters for frames in a non-interlacing scan format. Four graphs are shown. It can be seen that the curve labeled HPF-R3 has a cutoff frequency of 1 MHz and thus, retains portions of the frame with information above 1 MHz. Similarly, curve HPF-R2 has a cutoff frequency of 2 MHz, HPF-C2 has a cutoff frequency of 3 MHz and HPF-R1 and HPF-C1 have a cutoff frequency of 4 MHz. As will be discussed hereinbelow, the terminology "Rx" refers to operations on a row of pixels while the terminology "Cx" refers to operations on a column of pixels.

In particular, the filters of FIG. **4** implement the following finite impulse response (FIR) filters on either a row of pixels (the x direction of the frame) or a column of pixels (the y direction of the frame), where the number of pixels used in the filter defines the power of the cosine. For example, a filter implementing $\cos^{10} x$ takes 10 pixels around the pixel of interest, five to one side and five to the other side of the pixel of interest.

HPF-R3: $1 - \cos^{10} x$

HPF-R2: $1 - \cos^6 x$

HPF-R1: $1 - \cos^2 x$

HPF-C2: $1 - \cos^4 y$

HPF-C1: $1 - \cos^2 y$

The high pass filters can also be considered as digital equivalents of optical apertures. The higher the cut-off frequency, the smaller the aperture. Thus, filters HPF-R1 and HPF-C1 retain only very small details in the frame (of 1–4 pixels in size) while filter HPF-R3 retains much larger details (of up to 11 pixels).

In the following, the filtered frames will be labeled by the type of filter (HPF-X) used to create them.

Returning to FIG. **3**, analyzer **50** also generates difference frames between the current frame and another, earlier frame.

6

The previous frame is typically at most 15 frames earlier. A "group" of pictures or frames (GOP) is a series of frames for which difference frames are generated.

Parameter estimator **52** takes the current frame and the filtered and difference frames and generates a set of parameters that describe the information content of the current frame. The parameters are determined on a pixel-by-pixel basis or on a per frame basis, as relevant. It is noted that the parameters do not have to be calculated to great accuracy as they are used in combination to determine a per pixel, visual perception threshold THD_i .

At least some of the following parameters are determined:

Signal to noise ratio (SNR): this parameter can be determined by generating a difference frame between the current frame and the frame before it, high pass filtering of the difference frame, summing the intensities of the pixels in the filtered frame, normalized by both the number of pixels N in a frame and the maximum intensity I_{MAX} possible for the pixel. If the frame is a television frame, the maximum intensity is 255 quanta (8 bits). The high frequency filter selects only those intensities lower than 3σ , where σ indicates a level less than which the human eye cannot perceive noise. For example, σ can be 46 dB, equivalent to a reduction in signal strength of a factor of 200.

Normalized NA_i : this measures the change Δ_i , per pixel i , from the current frame to its previous frame. This value is then normalized by the maximum intensity I_{MAX} possible for the pixel.

Normalized volume of intraframe change NI_{XY} : this measures the volume of change in a frame I_{XY} (or how much detail there is in a frame), normalized by the maximum possible amount of information MAX_{INFO} within a frame (i.e. 8 bits per pixel $\times N$ pixels per frame). Since the highest frequency range indicates the amount of change in a frame, the volume of change I_{XY} is a sum of the intensities in the filtered frame having the highest frequency range, such as filtered frame HPF-R1.

Normalized volume of interframe changes NI_F : this measures the volume of changes I_F between the current frame and its previous frame, normalized by the maximum possible amount of information MAX_{INFO} within a frame. The volume of interframe changes I_F is the sum of the intensities in the difference frame.

Normalized volume of change within a group of frames NI_{GOP} : this measures the volume of changes I_{GOP} over a group of frames, where the group is from 2 to 15 frames, as selected by the user. It is normalized by the maximum possible amount of information MAX_{INFO} within a frame and by the number of frames in the group.

Normalized luminance level NY_i : Y_i is the luminance level of a pixel in the current frame. It is normalized by the maximum intensity I_{MAX} possible for the pixel.

Color saturation p_i : this is the color saturation level of the i th pixel and it is determined by:

$$\left[0.78 \left(\frac{C_{r,i} - 128}{160} \right)^2 + 0.24 \left(\frac{C_{b,i} - 128}{126} \right)^2 \right]^{1/2}$$

where $C_{r,i}$ and $C_{b,i}$ are the chrominance levels of the i th pixel.

Hue h_i : this is the general hue of the i th pixel and is determined by:

$$\arctan\left(1.4 \frac{C_{r,i} - 128}{C_{b,i} - 128}\right).$$

Alternatively, hue h_i can be determined by interpolating Table 1, below.

Response to hue $R_i(h_i)$: this is the human vision response to a given hue and is given by Table 1, below. Interpolation is typically used to produce a specific value of the response $R(h)$ for a specific value of hue h .

TABLE 1

Color	Y	C_r	C_b	h (nm)	$R(h)$
White	235	128	128	—	—
Yellow	210	16	146	575	0.92
Cyan	170	166	16	490	0.21
Green	145	54	34	510	0.59
Magenta	106	202	222	—	0.2
Red	81	90	240	630	0.3
Blue	41	240	110	475	0.11
Black	16	128	128	—	—

Visual perception threshold determiner **54** determines the visual perception threshold THD_i per pixel as follows:

$THD_i =$

$$THD_{\min}\left(1 + NA_i + NI_{XY} + NI_F + NI_{GOP} + NY_i + p_i + (1 - R_i(h_i)) + \frac{200}{SNR}\right)$$

Subclass determiner **56** compares each pixel i of each high pass filtered frame HPF-X to its associated threshold THD_i to determine whether or not that pixel is significantly present in each filtered frame, where “significantly present” is defined by the threshold level and by the “detail dimension” (i.e. the size of the object or detail in the image of which the pixel forms a part). Subclass determiner **56** then defines the subclass to which the pixel belongs.

For the example provided above, if the pixel is not present in any of the filtered frames, the pixel must belong to an object of large size or the detail is only detected but not distinguished. If the pixel is only found in the filtered frame of HPF-C2 or in both frames HPF-C1 and HPF-C2, it must be a horizontal edge (an edge in the Y direction of the frame). If it is found in filtered frames HPF-R3 and HPF-C2, it is a single small detail. If the pixel is found only in filtered frames HPF-R1, HPF-R2 and HPF-R3, it is a very small vertical edge. If, in addition, it is also found in filtered frame HPF-C2, then the pixel is a very small, single detail.

The above logic is summarized and expanded in Table 2.

TABLE 2

High Pass Filters						
Subclass	R1	R2	R3	C1	C2	Remarks
1	0	0	0	0	0	Large detail or detected detail only
2	0	0	0	0	1	Horizontal edge
3	0	0	0	1	1	Horizontal edge
4	0	0	1	0	0	Vertical edge
5	0	0	1	0	1	Single small detail
6	0	0	1	1	1	Single small detail
7	0	1	1	0	0	Vertical edge
8	0	1	1	0	1	Single small detail
9	0	1	1	1	1	Single small detail
10	1	1	1	0	0	Very small vertical edge
11	1	1	1	0	1	Very small single detail

TABLE 2-continued

High Pass Filters						
Subclass	R1	R2	R3	C1	C2	Remarks
12	1	1	1	1	1	Very small single detail

The output of subclass determiner **56** is an indication of the subclass to which each pixel of the current frame belongs. Intra-frame processor **44** performs spatial filtering of the frame, where the type of filter utilized varies in accordance with the subclass to which the pixel belongs.

In accordance with a preferred embodiment of the present invention, intra-frame processor **44** filters each subclass of the frame differently and according to the information content of the subclass. The filtering limits the bandwidth of each subclass which is equivalent to sampling the data at different frequencies. Subclasses with a lot of content are sampled at a high frequency while subclasses with little content, such as a plain background area, are sampled at a low frequency.

Another way to consider the operation of the filters is that they smooth the data of the subclass, removing “noisiness” in the picture that the human eye does not perceive. Thus, intra-frame processor **44** changes the intensity of the pixel by an amount less than the visual distinguishing threshold for that pixel. Pixels whose contrast is lower than the threshold (i.e. details which were detected only) are transformed with non-linear filters. If desired, the data size of the detected only pixels can be reduced from 8 bits to 1 or 2 bits, depending on the visual threshold level and the detail dimension for the pixel. For the other pixels (i.e. the distinguished ones), 3 or 4 bits is sufficient.

Intra-frame processor **44** comprises a controllable filter bank **60** and a filter selector **62**. Controllable filter bank **60** comprises a set of low pass and non-linear filters, shown in FIGS. **5A** and **5B** to which reference is now made, which filter selector **62** activates, based on the subclass to which the pixel belongs. Selector **62** can activate more than one filter, as necessary.

FIGS. **5A** and **5B** are two, alternative embodiments of controllable filter bank **60**. Both comprise two sections **64** and **66** which operate on columns (i.e. line to line) and on rows (i.e. within a line), respectively. In each section **64** and **66**, there is a choice of filters, each controlled by an appropriate switch, labeled SW-X, where X is one of C1, C2, R1, R2, R3 (selecting one of the low pass filters (LPF)), D-C, D-R (selecting to pass the relevant pixel directly). Filter selector **62** switches the relevant switch, thereby activating the relevant filter. It is noted that the non-linear filters NLF-R and NLF-C are activated by switches R3 and C2, respectively. Thus, the outputs of non-linear filters NLF-R and NLF-C are added to the outputs of low pass filters LPF-R3 and LPF-C2, respectively.

Controllable filter bank **60** also includes time aligners (TA) which add any necessary delays to ensure that the pixel currently being processed remains at its appropriate location within the frame.

The low pass filters (LPF) are associated with the high pass filters used in analyzer **50**. Thus, the cutoff frequencies of the low pass filters are close to those of the high pass filters. The low pass filters thus pass that which their associated high pass filters ignore.

FIG. **6**, to which reference is now briefly made, illustrates exemplary low pass filters for the example provided hereinabove. Low pass filter LPF-R3 has a cutoff frequency of 0.5

MHz and thus, generally does not retain anything which its associated high pass filter HPF-R3 (with a cutoff frequency of 1 MHz) retains. Filter LPF-R2 has a cutoff frequency of 1 MHz, filter LPF-C2 has a cutoff frequency of 1.25 MHz and filters LPF-C1 and LPF-R1 have a cutoff frequency of about 2 MHz. As for the high frequency filters, filters LPF-Cx operate on the columns of the frame and filters LPF-Rx operate on the rows of the frame.

FIG. 7, to which reference is now briefly made, illustrates an exemplary transfer function for the non-linear filters (NLF) which models the response of the eye when detecting a detail. The transfer function defines an output value V_{out} normalized by the threshold level THD_i , as a function of an input value V_{in} also normalized by the threshold level THD_i . As can be seen in the figure, the input-output relationship is described by a polynomial of high order. A typical order might be six, though lower orders, of power two or three, are also feasible.

Table 3 lists the type of filters activated per subclass, where the header for the column indicates both the type of filter and the label of the switch SW-X of FIGS. 5A and 5B.

TABLE 3

Subclass	Low Pass Filters						
	R1	R2	R3	C1	C2	D-R	D-C
1	0	0	1	0	1	0	0
2	0	0	1	1	0	0	0
3	0	0	1	0	0	0	1
4	0	1	0	0	1	0	0
5	0	1	0	1	0	0	0
6	0	1	0	0	0	0	1
7	1	0	0	0	1	0	0
8	1	0	0	1	0	0	0
9	1	0	0	0	0	0	1
10	0	0	0	0	1	1	0
11	0	0	0	1	0	1	0
12	0	0	0	0	0	1	1

FIG. 5B includes rounding elements RND which reduce the number of bits of a pixel from eight to three or four bits, depending on the subclass to which the pixel belongs. Table 4 illustrates the logic for the example presented hereinabove, where the items which are not active for the subclass are indicated by "N/A".

TABLE 4

subclass	RND-R0 (Z1)	RND-R1 (Z2)	RND-R2 (Z3)	RND-C0 (Z4)	RND-C1 (Z5)
1	N/A	N/A	N/A	N/A	N/A
2	N/A	N/A	N/A	N/A	4 bit
3	N/A	N/A	N/A	4 bit	N/A
4	N/A	N/A	4 bit	N/A	N/A
5	N/A	N/A	4 bit	N/A	4 bit
6	N/A	N/A	4 bit	4 bit	N/A
7	N/A	4 bit	N/A	N/A	N/A
8	N/A	3 bit	N/A	N/A	3 bit
9	N/A	3 bit	N/A	3 bit	N/A
10	4 bit	N/A	N/A	N/A	N/A
11	3 bit	N/A	N/A	N/A	3 bit
12	3 bit	N/A	N/A	3 bit	N/A

The output of intra-frame processor 44 is a processed version of the current frame which uses fewer bits to describe the frame than the original version.

Reference is now made to FIGS. 8A, 8B and 8C, which illustrate three alternative embodiments for inter-frame processor 48 which provides temporal filtering (i.e. inter-frame filtering) to further process the current frame. Since the

present invention provides a full frame as output, inter-frame processor 48 determines which pixels have changed significantly from the previous frame and amends those only, storing the new version in the appropriate location in output frame memory 46.

The embodiments of FIGS. 8A and 8B are open loop versions (i.e. the previous frame is the frame previously input into inter-frame processor 48) while the embodiment of FIG. 8C is a closed loop version (i.e. the previous frame is the frame previously produced by inter-frame processor 48). All of the embodiments comprise a summer 68, a low pass filter (LPF) 70, a high pass filter (HPF) 72, two comparators 74 and 76, two switches 78 and 80, controlled by the results of comparators 74 and 76, respectively, and a summer 82. FIGS. 8A and 8B additionally include an intermediate memory 84 for storing the output of intra-frame processor 44.

Summer 68 takes the difference of the processed current frame, produced by processor 44, and the previous frame, stored in either intermediate memory 84 (FIGS. 8A and 8B) or in frame memory 46 (FIG. 8C). The difference frame is then processed in two parallel tracks.

In the first track, the low pass filter is used. Each pixel of the filtered frame is compared to a general, large detail, threshold $THD-LF$ which is typically set to 5% of the maximum expected intensity for the frame. Thus, the pixels which are kept are only those which changed by more than 5% (i.e. those whose changes can be "seen" by the human eye).

In the second track, the difference frame is high pass filtered. Since high pass filtering retains the small details, each pixel of the high pass filtered frame is compared to the particular threshold THD , for that pixel, as produced by threshold determiner 54. If the difference pixel has an intensity above the threshold THD_i (i.e. the change in the pixel is significant for detailed visual perception), it is allowed through (i.e. switch 80 is set to pass the pixel).

Summer 82 adds the filtered difference pixels passed by switches 78 and/or 80 with the pixel of the previous frame to "produce the new pixel". If switches 78 and 80 did not pass anything, the new pixel is the same as the previous pixel. Otherwise, the new pixel is the sum of the previous pixel and the low and high frequency components of the difference pixel.

Reference is now briefly made to FIGS. 9, 10A, 10B and 11 which detail elements of frame analyzer 42. In these figures, the term "ML" indicates a memory line of the current frame, "MP" indicates a memory pixel of the current frame, "MF" indicates a memory frame, "VD" indicates the vertical drive signal, "TA" indicates a time alignment, e.g. a delay, and CNT indicates a counter.

FIG. 9 generally illustrates the operation of spatial-temporal analyzer 50 and FIGS. 10A and 10B provide one detailed embodiment for the spatial analysis and temporal analysis portions 51 and 53, respectively. FIG. 11 details parameter estimator 52, threshold determiner 54 and subclass determiner 56. As these figures are deemed to be self-explanatory, no further explanation will be included here.

It is noted that the present invention can be implemented with a field programmable gate array (FPGA) and the frame memory can be implemented with SRAM or SDRAM.

The methods and apparatus disclosed herein have been described without reference to specific hardware or software. Rather, the methods and apparatus have been described in a manner sufficient to enable persons of ordinary skill in the art to readily adapt commercially available hardware and software as may be needed to reduce any of

11

the embodiments of the present invention to practice without undue experimentation and using conventional techniques.

It will be appreciated by persons skilled in the art that the present invention is not limited by what has been particularly shown and described herein above. Rather the scope of the invention is defined by the claims that follow:

What is claimed is:

1. A visual perception threshold unit for image processing, the threshold unit comprising:

a parameter generator to generate a multiplicity of parameters that describe at least some [of the] information content of at least one *video* frame to be processed; and
a threshold generator to generate from said parameters, a plurality of visual perception threshold levels to be associated with [the] pixels of the *at least one* video frame,

wherein said threshold levels define contrast levels above which a human eye can distinguish a pixel from among its neighboring pixels of said *at least one* video frame.

2. A unit according to claim 1 [and], wherein said parameter generator comprises at least one of the following units:

a volume unit which determines [the] a volume of information in said at least one *video* frame;

a color unit which determines a per pixel color; and

an intensity unit which determines a cross-frame change of intensity.

3. A method of generating visual perception thresholds for image processing *implemented by one or more elements of a video encoding device*, the method comprising:

analyzing details of frames of a video signal;

estimating parameters of said details; and

defining a visual perception threshold for each of said details in accordance with said estimated detail parameters,

wherein said estimating comprises at least one of the following:

determining a per-pixel signal intensity change between a current frame and a previous frame, normalized by a maximum intensity;

determining a normalized volume of intraframe change by high frequency filtering of said *current* frame, summing the intensities of said filtered frame and normalizing the resultant sum by [the] a maximum possible amount of information within a frame;

generating a volume of inter-frame changes between [a] said current frame and [its] said previous frame normalized by said maximum possible amount of information [volume] within a frame;

generating a normalized volume of inter-frame changes for a group of [pictures] frames from the output of said previous step of generating;

evaluating a signal-to-noise ratio by high pass filtering a difference frame between said current frame and [its] said previous frame by selecting [those] intensities of said difference frame lower than a threshold defined as three times a noise level under which noise intensities are not perceptible to the human eye, summing the intensities of the pixels in the filtered *difference* frame and normalizing said sum by said maximum intensity and by [the] a total number of pixels in a frame;

generating a normalized intensity value per-pixel;

generating a per-pixel color saturation level;

generating a per-pixel hue value; and

determining a per-pixel response to said hue value.

12

4. A method for describing an image *implemeneted by one or more elements of a video encoding device*, the method comprising

determining which details in said image can be distinguished by the human eye and which ones can only be detected by it;

providing one bit to describe a pixel which can only be detected by the human eye; and

providing three bits to describe a pixel which can be distinguished by the human eye.

5. A video compression system comprising:

a parameter generator to generate one or more parameters that describe information content of a video frame; and

a threshold generator to generate, from at least one of the parameters, a plurality of visual perception threshold levels to be associated with pixels of the video frame, wherein said threshold levels define contrast levels above which a pixel of the video frame can be visually distinguished from its neighboring pixels of the video frame.

6. A video compression system according to claim 5, wherein the parameter generator comprises a volume unit configured to determine a volume of information in the video frame.

7. A video compression system according to claim 5, wherein the parameter generator comprises a color unit configured to determine a per pixel color.

8. A video compression system according to claim 5, wherein the parameter generator comprises an intensity unit configured to determine a cross-frame change of intensity.

9. A video compression system according to claim 5, wherein the parameter generator and the threshold generator are implemented in a field programmable gate array (FPGA).

10. A video encoder comprising:

a parameter generator to generate multiple parameters that describe information content of a video frame; and

a threshold generator to generate, from at least one of the multiple parameters, a plurality of visual perception threshold levels to be associated with pixels of the video frame, wherein said threshold levels define contrast levels above which a pixel of the video frame can be visually distinguished from its neighboring pixels of the video frame.

11. A video encoder according to claim 10, wherein the parameter generator comprises a volume unit configured to determine a volume of information in the video frame.

12. A video encoder according to claim 10, wherein the parameter generator comprises a color unit configured to determine a per pixel color.

13. A video encoder according to claim 10, wherein the parameter generator comprises an intensity unit configured to determine a cross-frame change of intensity.

14. A video encoder according to claim 10, wherein the video encoder is embodied in a field programmable gate array (FPGA).

15. A video encoder according to claim 10, wherein the video encoder comprises a visual lossless syntactic encoder.

16. A system comprising:

means for generating one or more parameters that describe information content of a video frame; and

means for generating, from at least one of the parameters, a plurality of visual perception threshold levels to be associated with pixels of the video frame, wherein said threshold levels define contrast levels above which a

13

pixel of the video frame can be visually distinguished from its neighboring pixels of the video frame.

17. *A system according to claim 16, wherein the one or more parameters are associated with at least one of:*

a volume of information in the video frame;

a cross-frame change of intensity; or

a per pixel color.

18. *A system according to claim 16, wherein the system is embodied in a field programmable gate array (FPGA).*

19. *A video compression system comprising:*

means for analyzing one or more details associated with one or more frames of a video signal;

means for estimating parameters of individual analyzed details; and

means for defining a visual perception threshold for individual analyzed details in accordance with at least one of the estimated parameters,

wherein said means for estimating comprises at least one of:

means for determining a per-pixel signal intensity change between a current frame and a previous frame, normalized by a maximum intensity;

means for determining a normalized volume of intraframe change by high frequency filtering of said current frame, summing the intensities of said filtered frame and normalizing the resultant sum by a maximum possible amount of information within a frame;

means for generating a volume of inter-frame changes between said current frame and said previous frame normalized by said maximum possible amount of information within a frame;

means for generating a normalized volume of inter-frame changes within a group of frames normalized by said maximum possible amount of information within a frame and by a number of frames comprising said group of frames;

means for evaluating a signal-to-noise ratio by high pass filtering a difference frame between said current frame and said previous frame by selecting intensities of said difference frame lower than a threshold defined as three times a noise level under which noise intensities are not visually perceptible, summing the intensities of pixels in the filtered difference frame and normalizing said sum by said maximum intensity and by the total number of pixels in a frame;

means for generating a normalized intensity value per-pixel;

means for generating a per-pixel color saturation level;

means for generating a per-pixel hue value; or

means for determining a per-pixel response to said hue value.

14

20. *A video compression system according to claim 19, embodied in a field programmable gate array (FPGA).*

21. *A method implemented by one or more elements of a video encoding device comprising:*

5 *identifying one or more distinguishable details in an image, individual distinguishable details being associated with a contrast level at which a pixel can be visually distinguished from among its neighboring pixels;*

using a plurality of bits to describe individual identified distinguishable details; and

10 *using less than said plurality of bits to describe one or more individual details in the image not identified as distinguishable.*

22. *A method according to claim 21, further comprising identifying the one or more of the individual details in the image not identified as distinguishable as being visually detectable.*

23. *A method according to claim 21, wherein using the plurality of bits comprises using three bits.*

24. *A method according to claim 21, further comprising performing the identifying, the using the plurality of bits, and the using less than said plurality of bits by the one or more elements embodied in a field programmable gate array (FPGA).*

25. *A system comprising:*

25 *means for identifying one or more distinguishable details in an image, individual distinguishable details being associated with a contrast level at which a pixel can be visually distinguished from among its neighboring pixels;*

30 *means for using a plurality of bits to describe individual identified distinguishable details; and*

means for using less than said plurality of bits to describe one or more individual details in the image not identified as distinguishable.

26. *A system according to claim 25, wherein one or more of the individual details in the image not identified as distinguishable are identified as being visually detectable.*

27. *A system according to claim 25, wherein the plurality of bits comprises three bits.*

28. *A system according to claim 25 comprising part of a field programmable gate array (FPGA).*

29. *A visual perception threshold unit according to claim 1, wherein one or both of the parameter generator or the threshold generator are implemented in a video encoder.*

30. *A visual perception threshold unit according to claim 29, wherein the video encoder comprises a visual lossless syntactic encoder.*

31. *A visual perception threshold unit according to claim 1 comprising part of a field programmable gate array (FPGA).*

* * * * *

UNITED STATES PATENT AND TRADEMARK OFFICE
CERTIFICATE OF CORRECTION

PATENT NO. : RE42,148 E
APPLICATION NO. : 12/196180
DATED : February 15, 2011
INVENTOR(S) : Sheraizin et al.

Page 1 of 1

It is certified that error appears in the above-identified patent and that said Letters Patent is hereby corrected as shown below:

Title page, item (76), under "Inventors", in Column 1, Line 1, delete "Harnagen" and insert -- Hamagen --.

Title page, item (76), under "Inventors", in Column 1, Line 2, delete "78604" and insert -- 76804 --.

Title page, item (76), under "Inventors", in Column 1, Line 3, delete "Harnagen" and insert -- Hamagen --.

Title page, item (76), under "Inventors", in Column 1, Line 4, delete "78604" and insert -- 76804 --.

Page 3, item (56), under "Other Publications", in Column 1, Line 30, delete "sytem" and insert -- system --.

Page 3, item (56), under "Other Publications", in Column 1, Line 33, delete "convex- projection" and insert -- convex-projection --.

Page 3, item (56), under "Other Publications", in Column 1, Line 51, delete "cicuits" and insert -- circuits --.

Page 3, item (56), under "Other Publications", in Column 1, Line 58, after "enhancement" delete "Enhancement".

Page 3, item (56), under "Other Publications", in Column 2, Line 8, delete "spatially" and insert -- spatially --.

Signed and Sealed this
Fourth Day of October, 2011

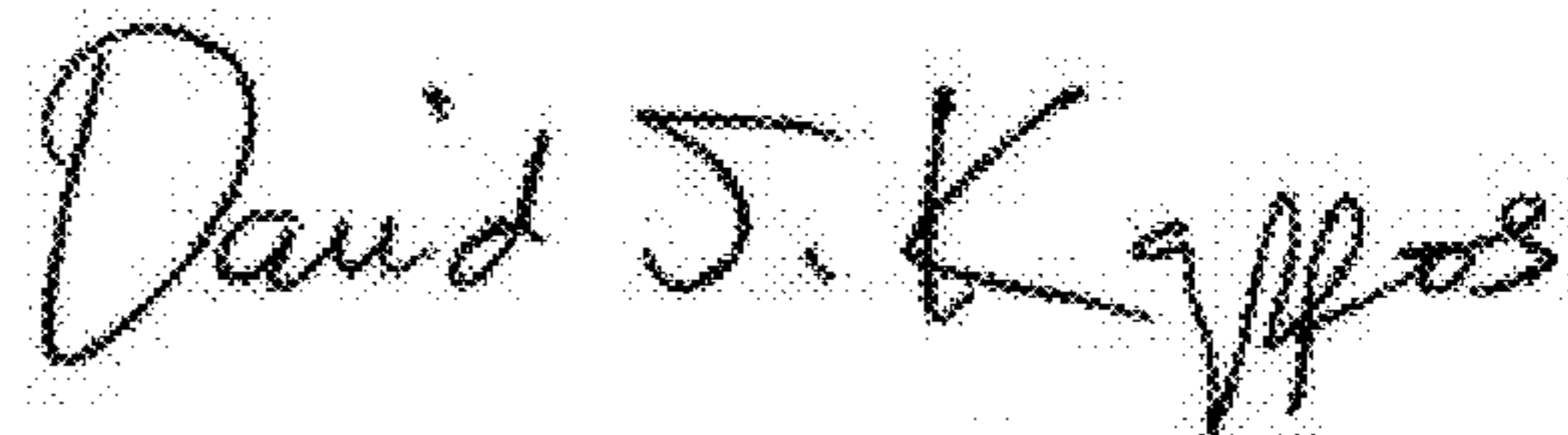

David J. Kappos
Director of the United States Patent and Trademark Office