



US00RE42112E

(19) **United States**
(12) **Reissued Patent**
Han et al.

(10) **Patent Number:** **US RE42,112 E**
(45) **Date of Reissued Patent:** **Feb. 8, 2011**

(54) **CHIP LIGHT EMITTING DIODE AND FABRICATION METHOD THEREOF**

7,207,706 B2 * 4/2007 Leu et al. 362/612
7,256,428 B2 * 8/2007 Braune et al. 257/100

(75) Inventors: **Kwan-Young Han**, Seoul (KR);
Do-Hyung Kim, Suwon (KR);
Seung-Man Yang, Seoul (KR);
Chung-Hoon Lee, Seoul (KR);
Hong-San Kim, Seongnam (KR);
Kwang-Il Park, Seoul (KR)

(Continued)

FOREIGN PATENT DOCUMENTS

(73) Assignee: **Seoul Semiconductor Co., Ltd.**, Seoul (KR)

JP	48-012802	1/1973
JP	01-068200	1/1991
JP	06-112536	4/1994
JP	09-153646	6/1997
JP	2000-058925	2/2000
JP	2001-177156	6/2001
JP	2002-141558	5/2002
JP	2002-164583	6/2002
JP	2002-299697	10/2002
JP	2003-204083	7/2003
WO	2003/040784	5/2003

(21) Appl. No.: **11/652,468**

(22) Filed: **Jan. 11, 2007**

Related U.S. Patent Documents

Reissue of:

(64) Patent No.: **7,042,022**
Issued: **May 9, 2006**
Appl. No.: **10/754,389**
Filed: **Jan. 9, 2004**

OTHER PUBLICATIONS

Advisory Action dated Sep. 23, 2005 in U.S. Appl. No. 10/754,389.
Final Office Action dated Jul. 12, 2005 in U.S. Appl. No. 10/754,389.
Non-Final Office Action dated Nov. 1, 2004 in U.S. Appl. No. 10/754,389.
Notice of Allowance dated Dec. 20, 2005 in U.S. Appl. No. 10/754,389.

(30) **Foreign Application Priority Data**

Jul. 25, 2003 (KR) 2003-51365
Aug. 19, 2003 (KR) 2003-57331
Aug. 20, 2003 (KR) 2003-57625

Primary Examiner—Nathan W Ha
(74) *Attorney, Agent, or Firm*—H.C. Park & Associates, PLC

(51) **Int. Cl.**
H01L 29/22 (2006.01)

(57) **ABSTRACT**

(52) **U.S. Cl.** **257/99; 257/E33.066; 257/100; 257/433**

(58) **Field of Classification Search** **257/98-100, 257/433, E33.066, 101; 438/22**
See application file for complete search history.

A chip light emitting diode having a wide viewing angle, and a fabrication method thereof. The chip light emitting diode has a resin package sealing a light emitting chip which has at least one curved projecting part. The curved projecting part has a cross section which is substantially semicircular, or substantially or partially elliptical or parabolic. The curved projecting part preferably has a cross section which is comprised of a plurality of straight lines, an angle being formed between adjacent lines. The cross section is elongated to form a cylindrical outer surface of the resin package.

(56) **References Cited**

U.S. PATENT DOCUMENTS

6,608,334 B1 8/2003 Ishinaga
6,746,295 B2 6/2004 Sorg
6,774,405 B2 8/2004 Yasukawa et al.
6,833,566 B2 * 12/2004 Suehiro et al. 257/99

40 Claims, 9 Drawing Sheets

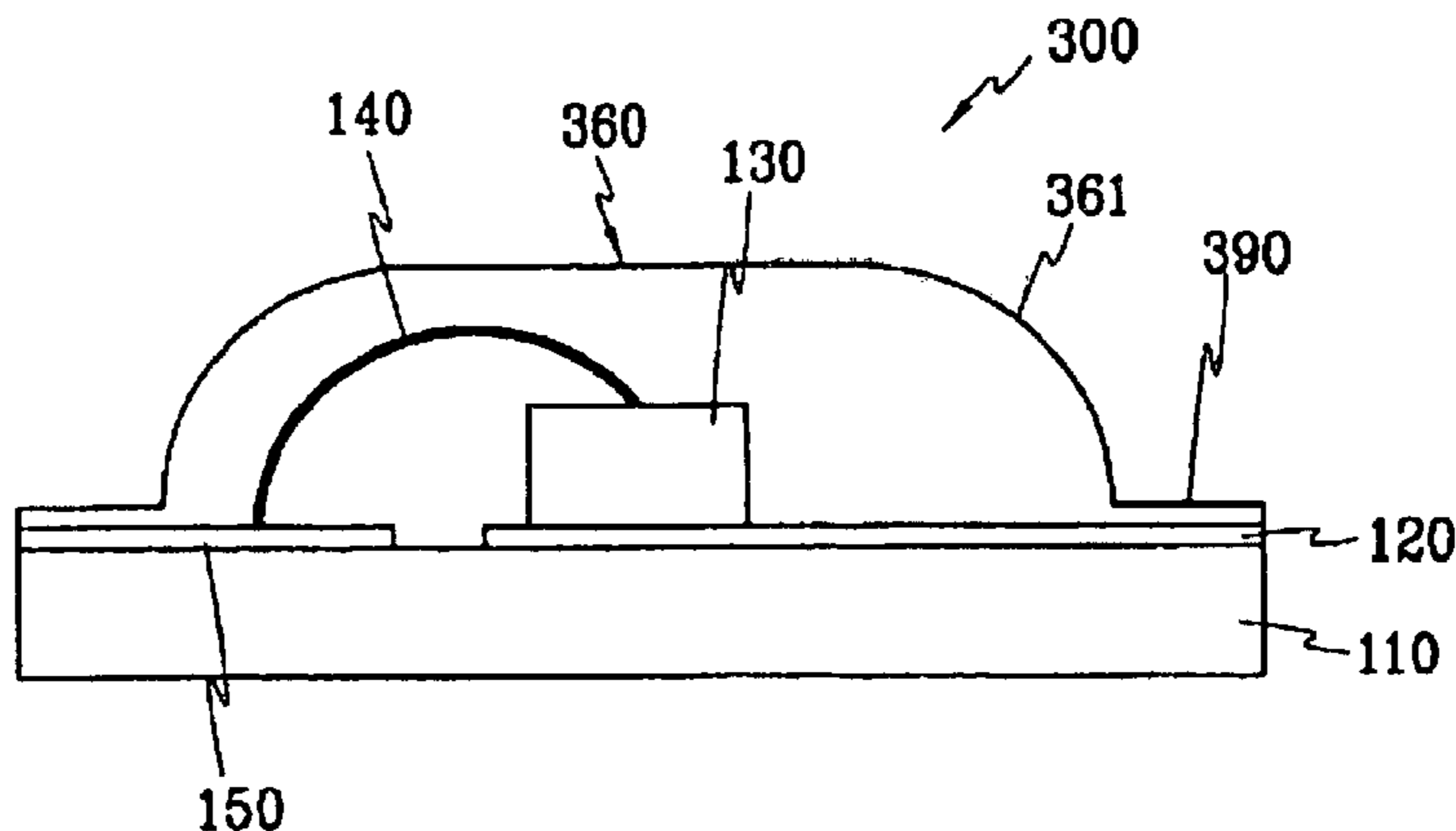

US RE42,112 E

Page 2

U.S. PATENT DOCUMENTS

7,282,748	B2 *	10/2007	Takeda et al.	257/98	2002/0139990	A1 *	10/2002	Suehiro et al.	257/99
7,290,902	B2 *	11/2007	Suehiro et al.	362/347	2003/0020077	A1 *	1/2003	Horiuchi et al.	257/81
7,352,011	B2 *	4/2008	Smits et al.	257/99	2003/0089914	A1 *	5/2003	Chen	257/79
7,388,232	B2 *	6/2008	Suehiro et al.	257/98	2003/0183836	A1 *	10/2003	Takekuma et al.	257/99
7,690,817	B2 *	4/2010	Sanpei et al.	362/294	2004/0070001	A1	4/2004	Lee et al.	257/99
2002/0113245	A1	8/2002	Lin		2005/0082561	A1	4/2005	Suehiro et al.	
					2005/0110035	A1	5/2005	Chen	

* cited by examiner

FIG.1(Prior Art)

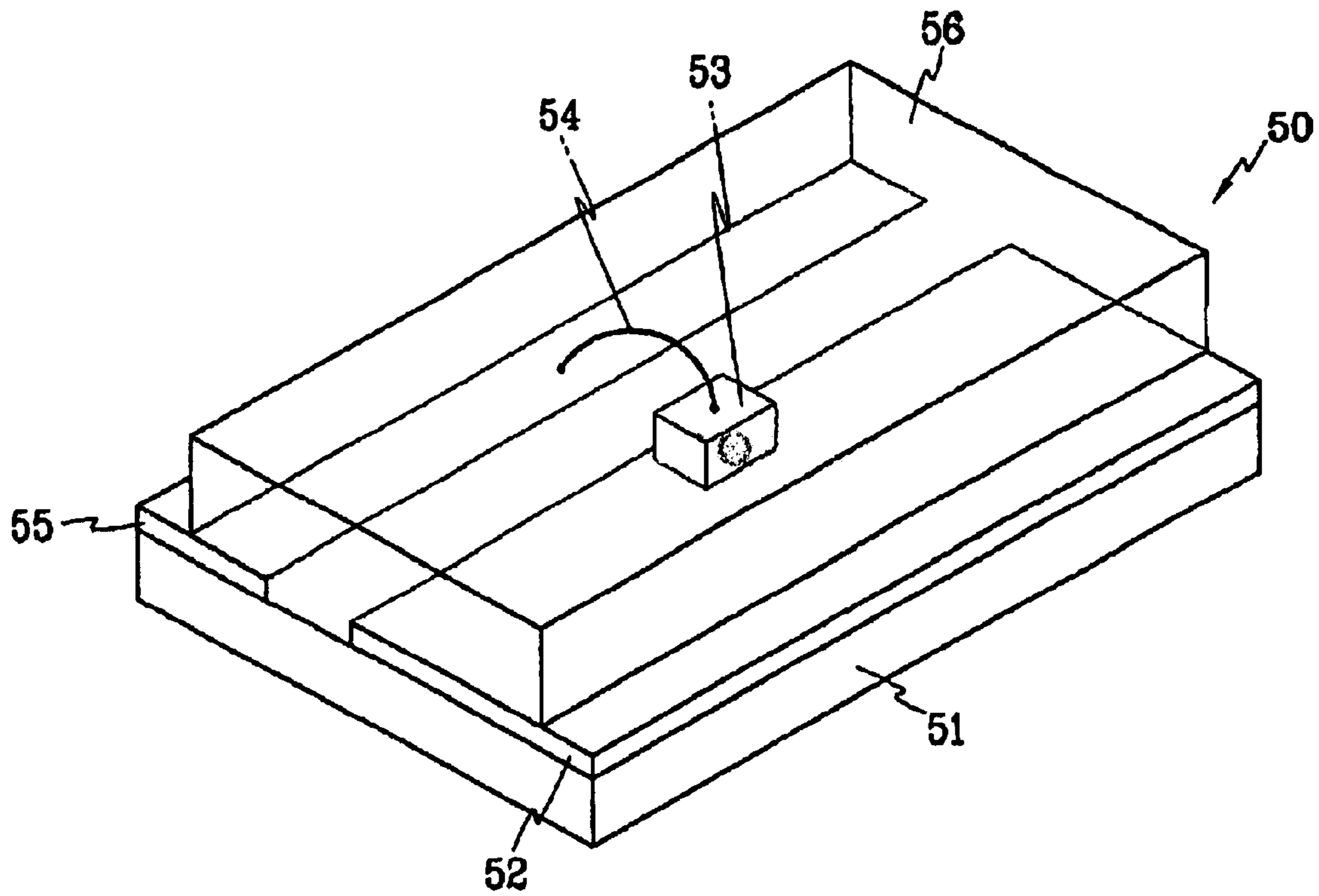

FIG. 2

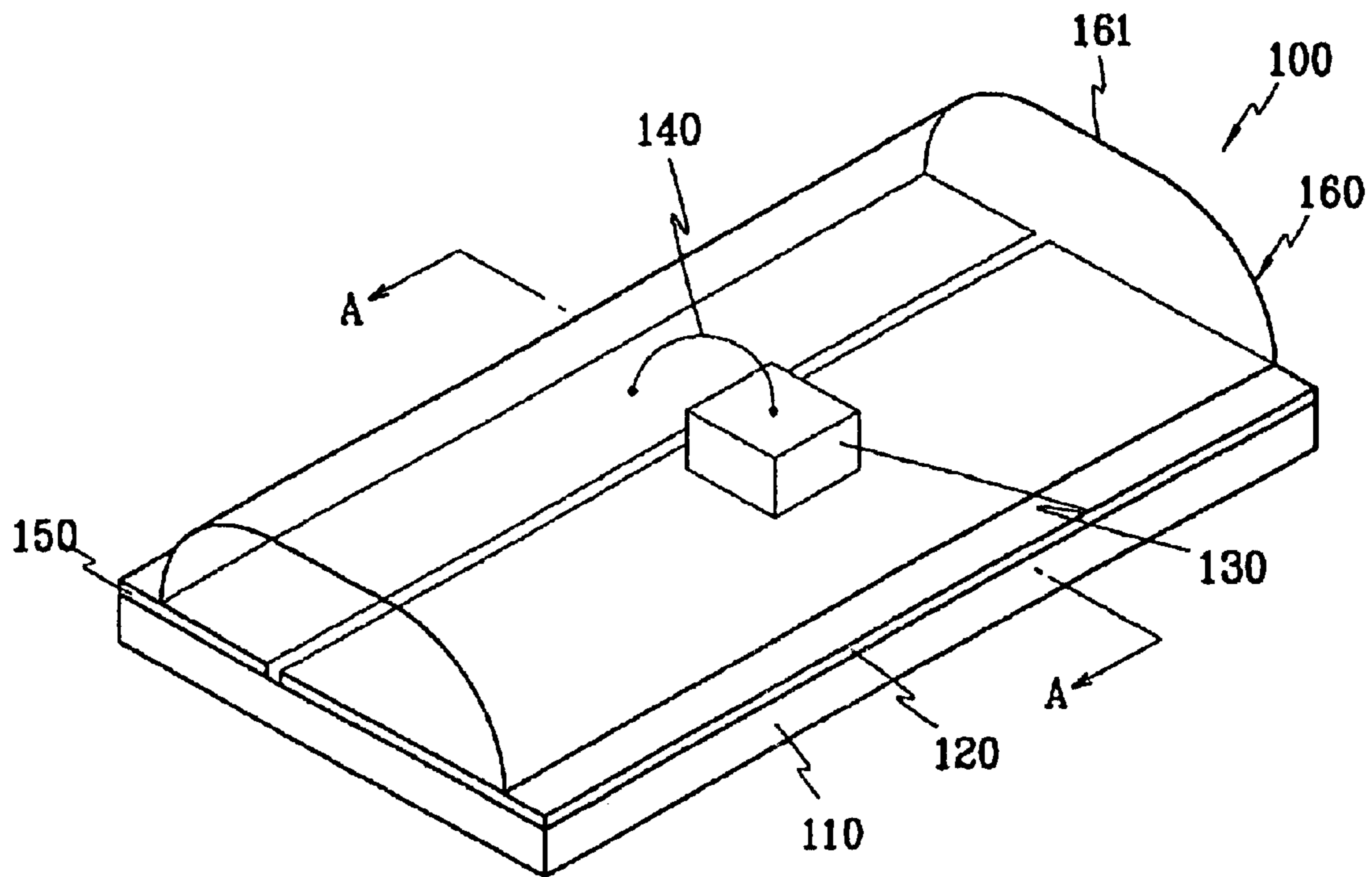

FIG. 3

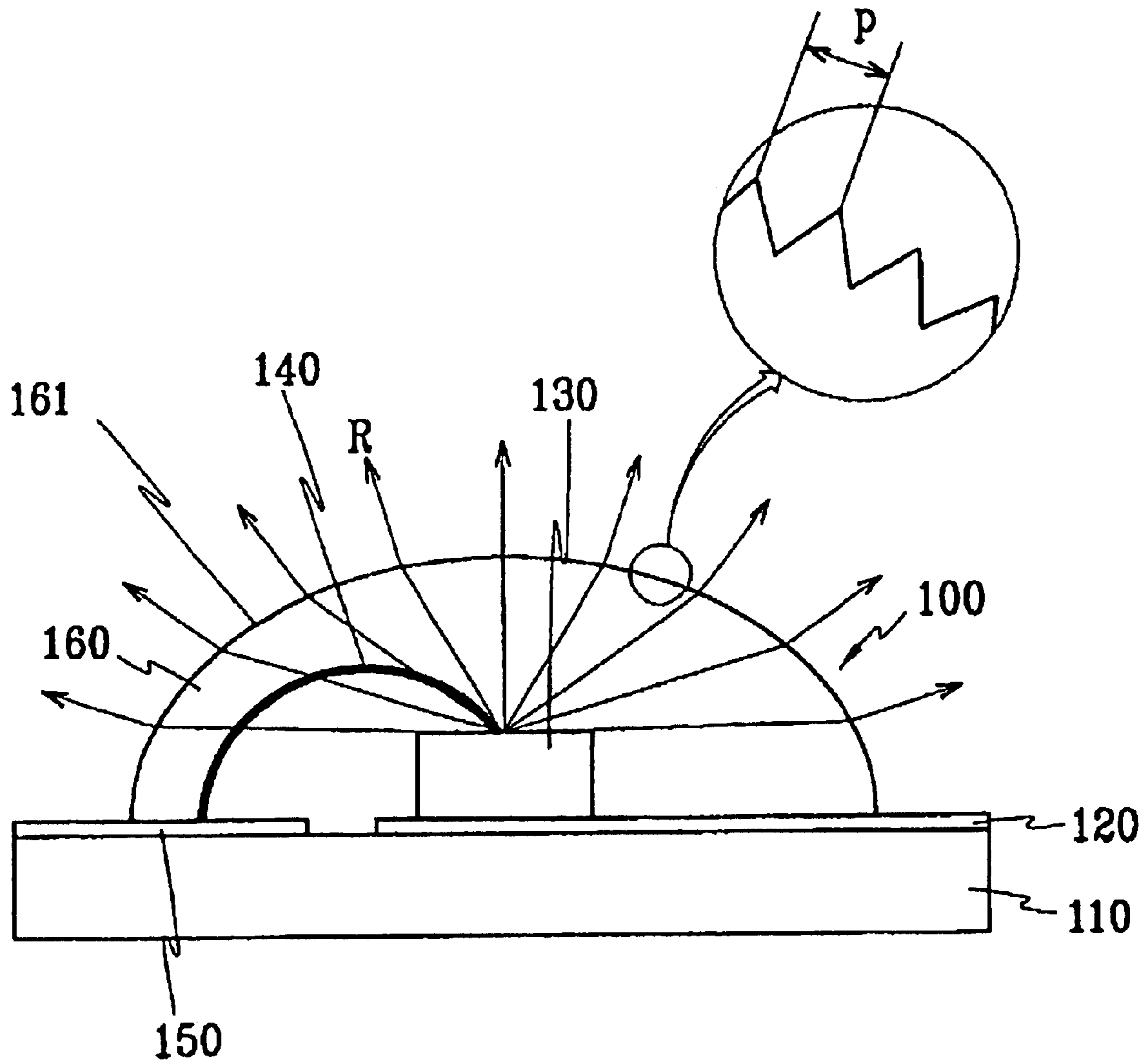

FIG. 4A

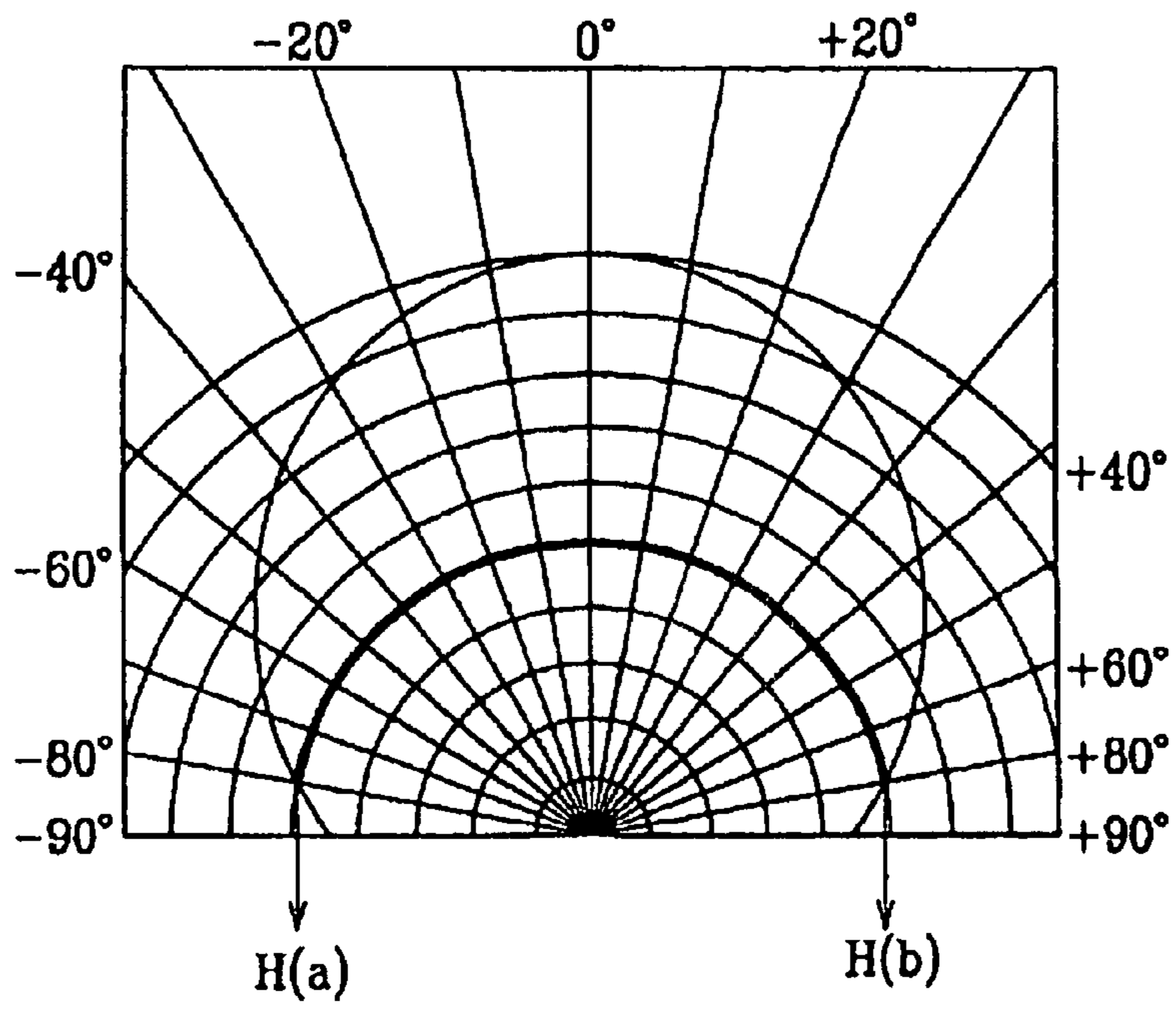

FIG. 4B

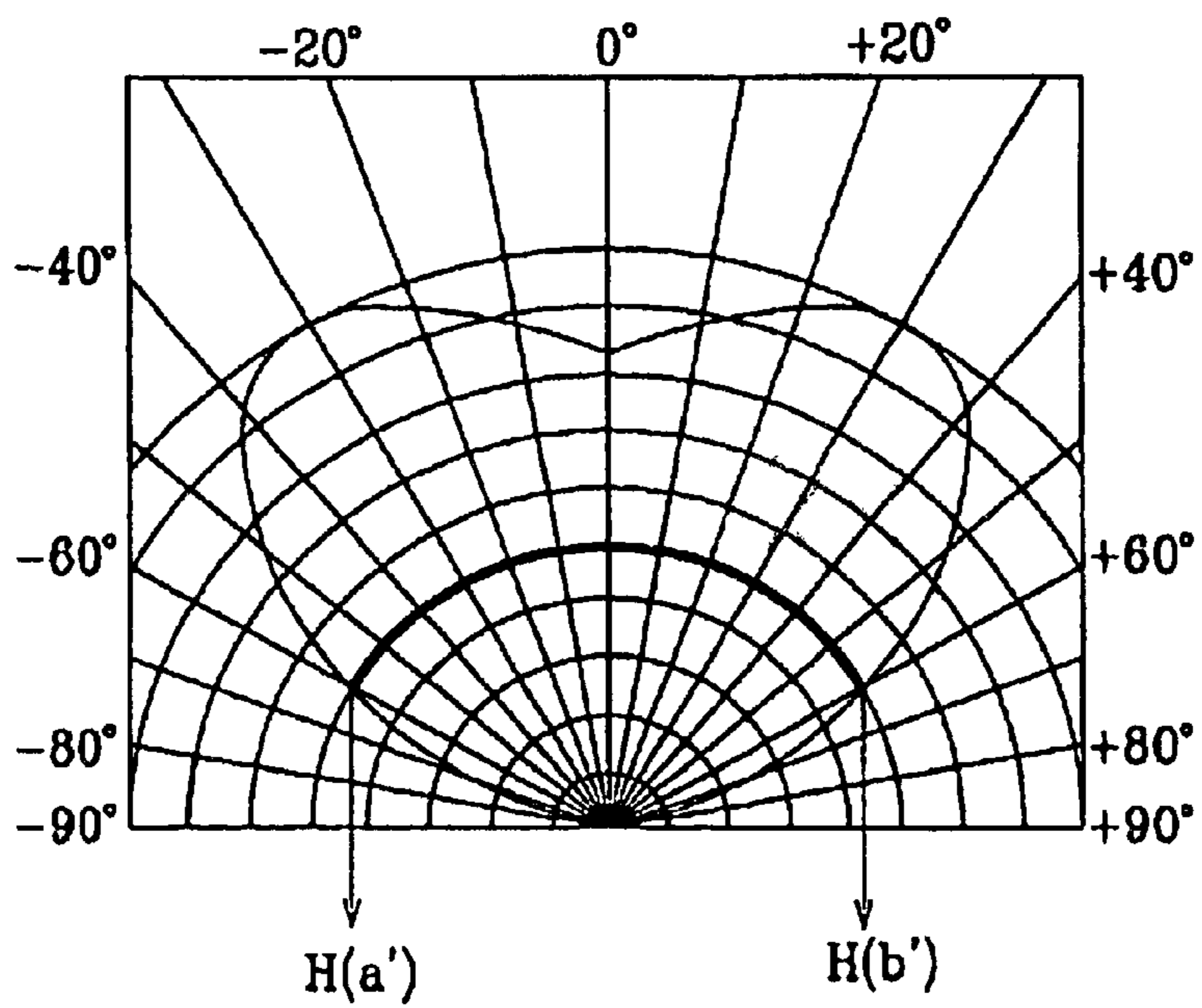

FIG. 5

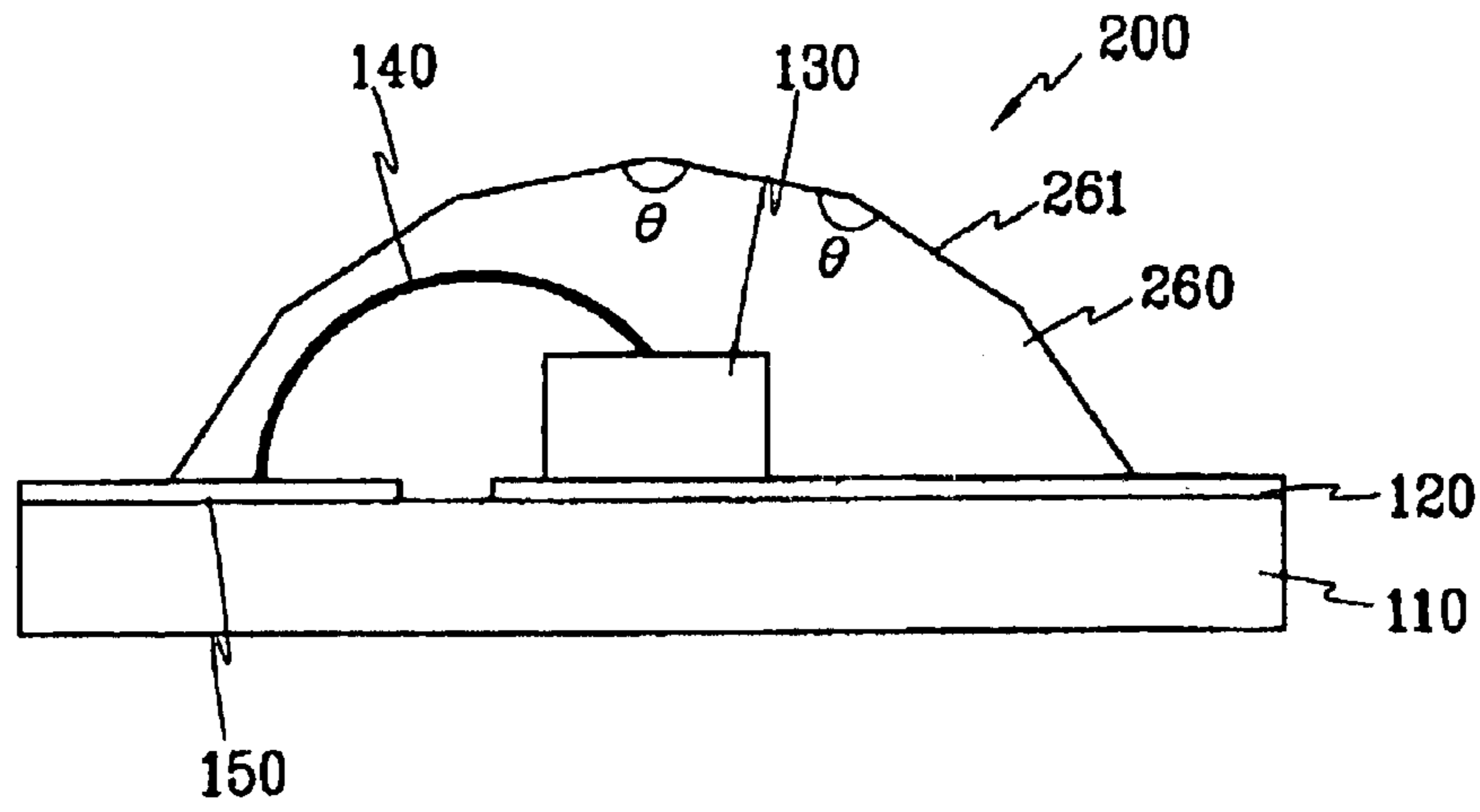

FIG. 6

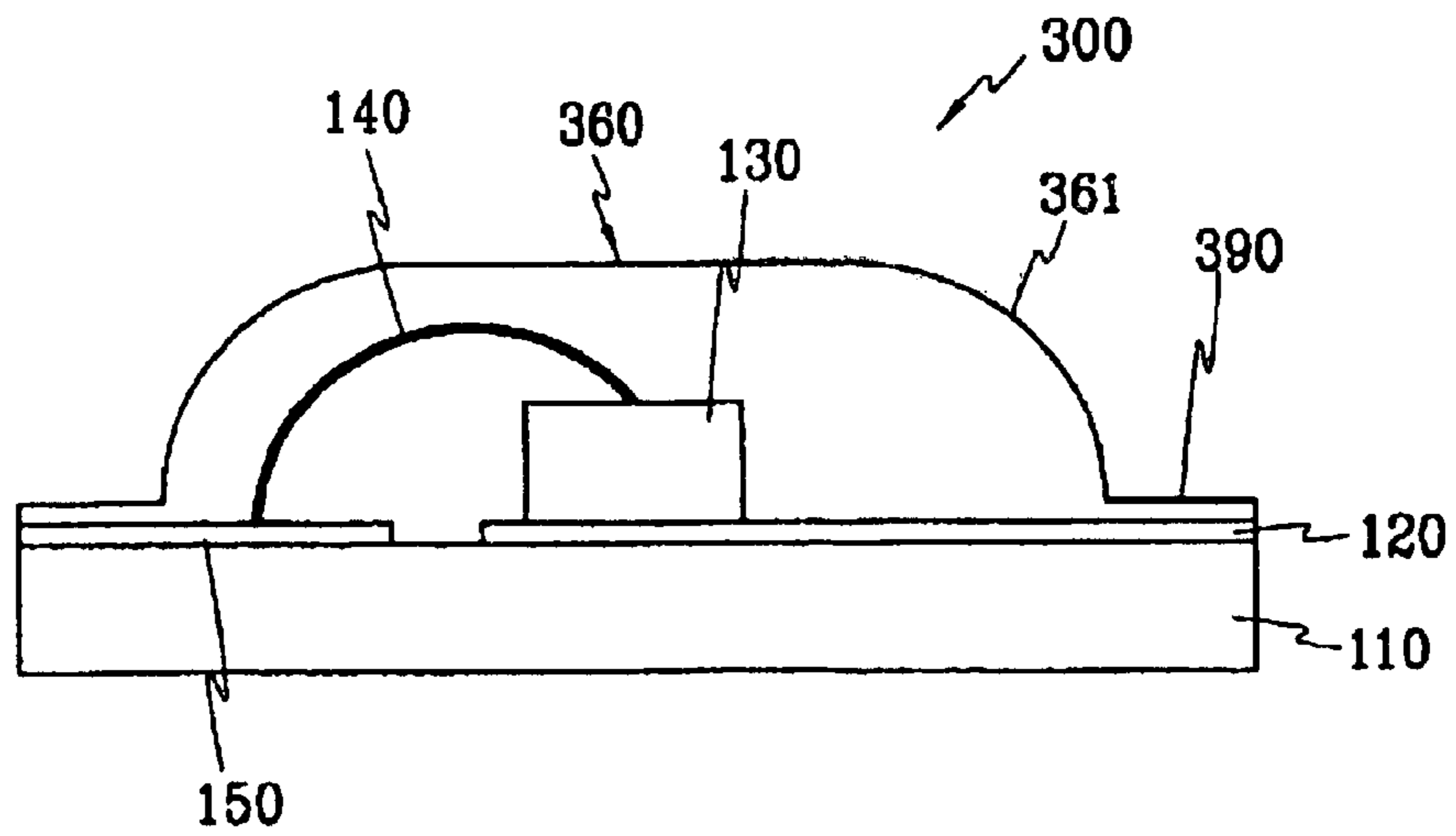

FIG. 7

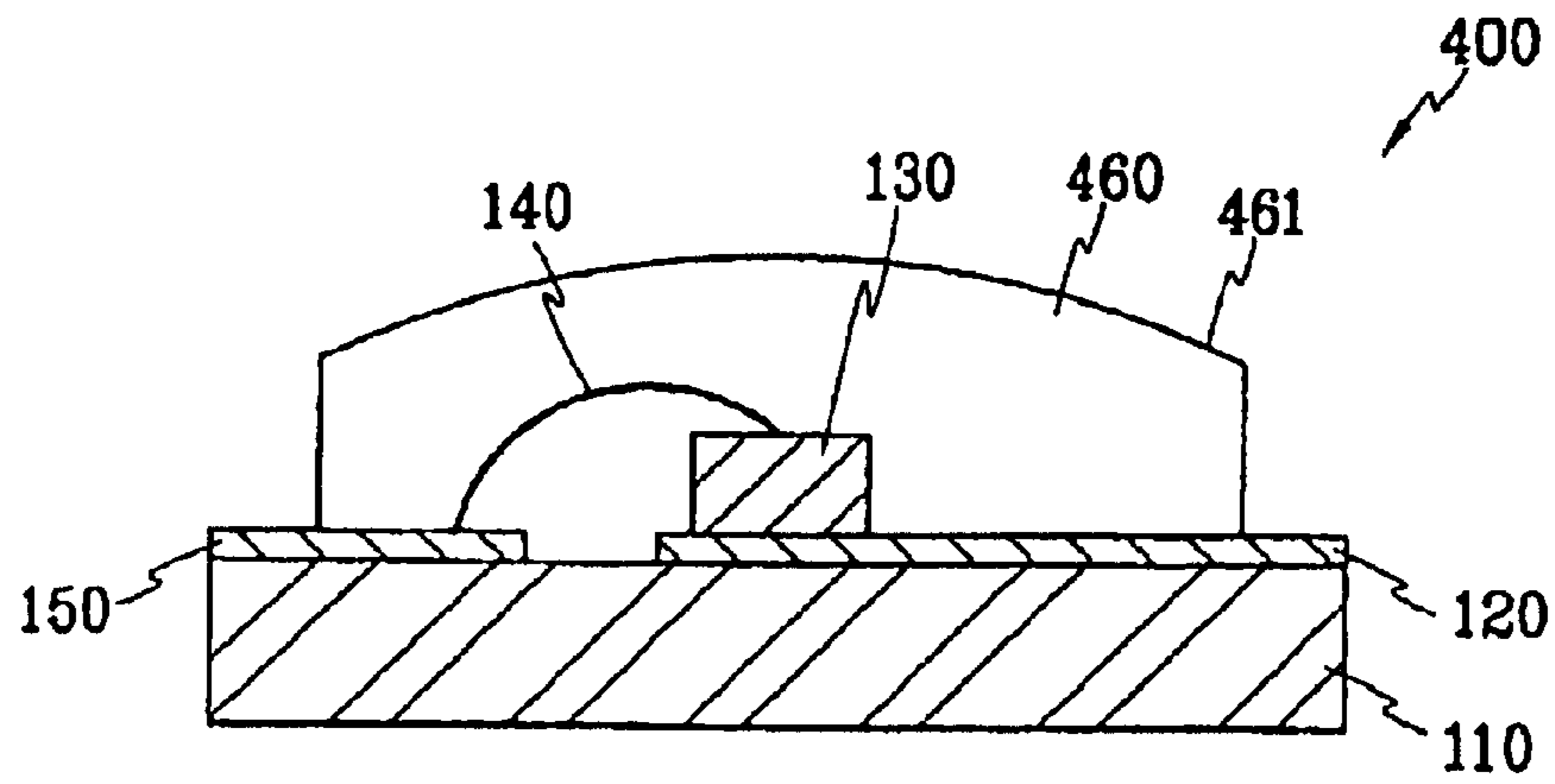

FIG. 8

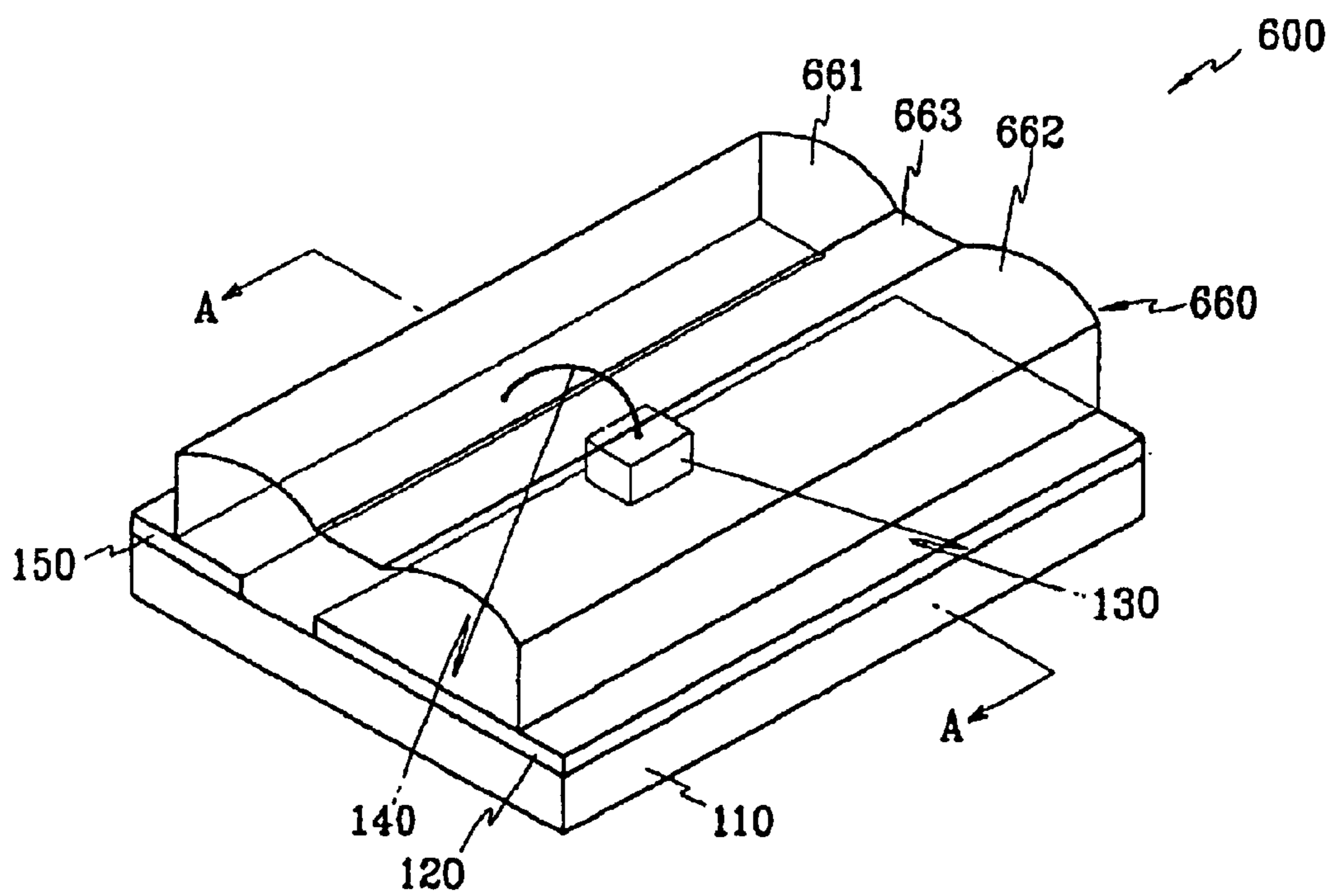

FIG. 9

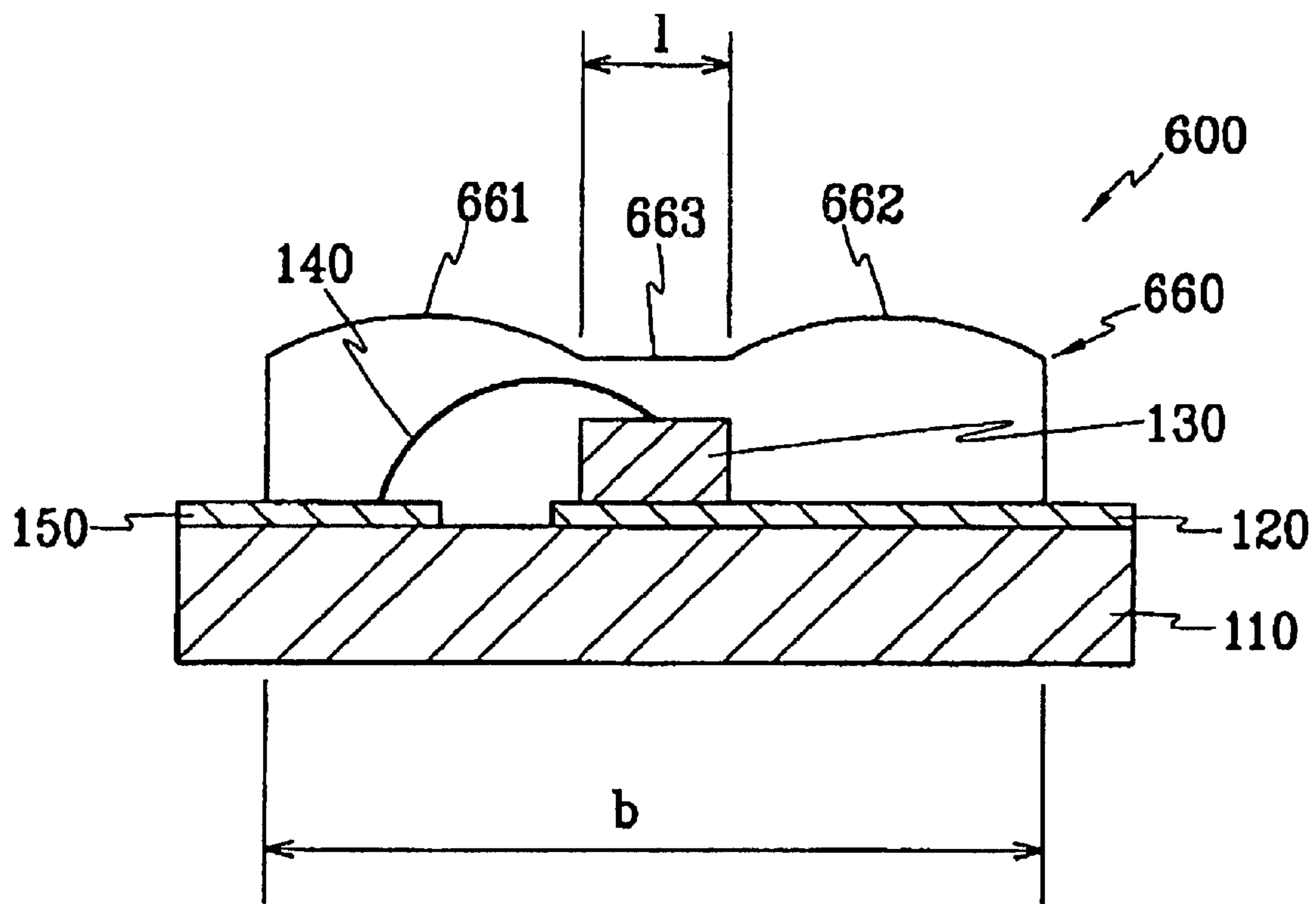

FIG.10

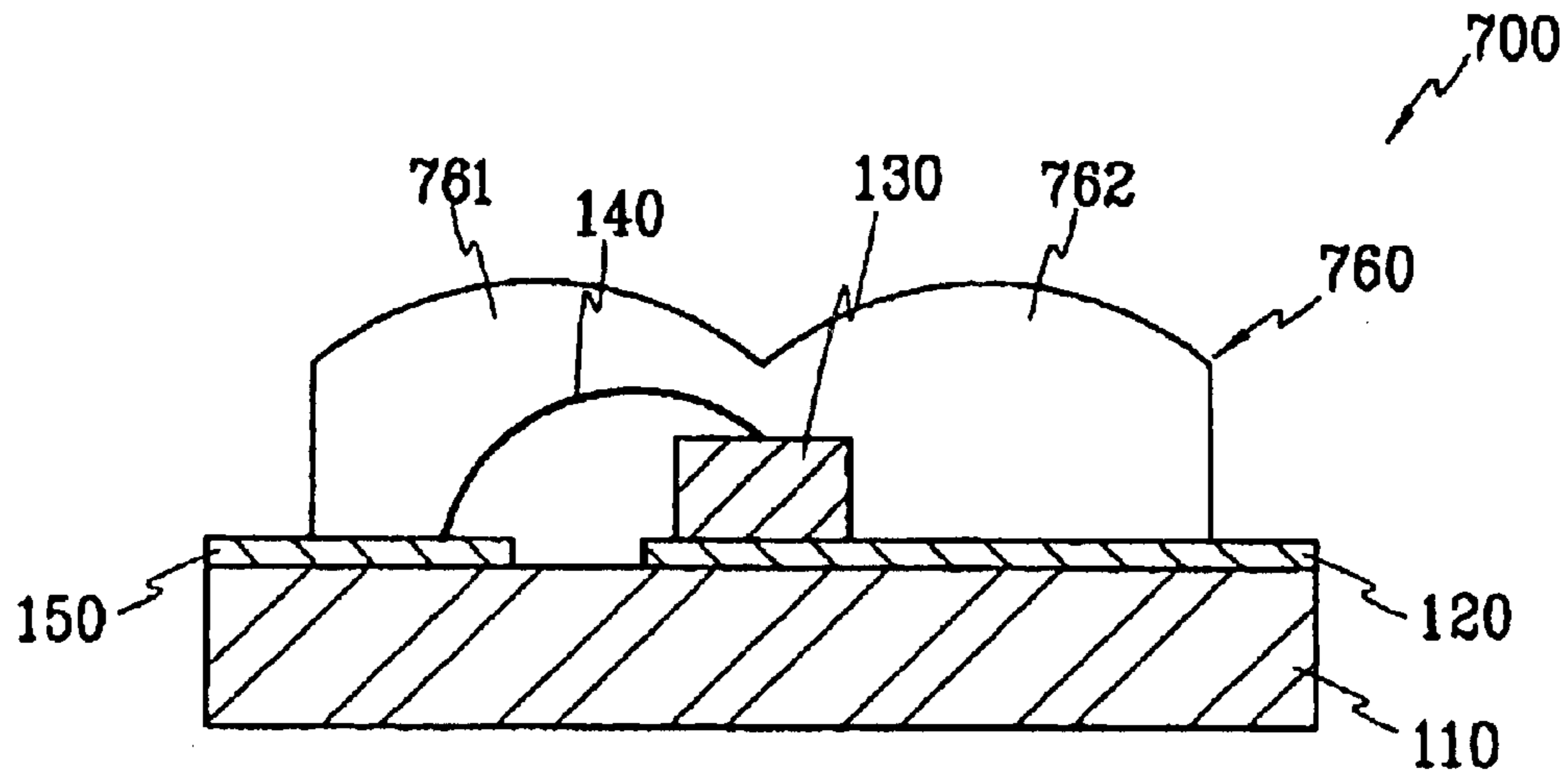

FIG.11

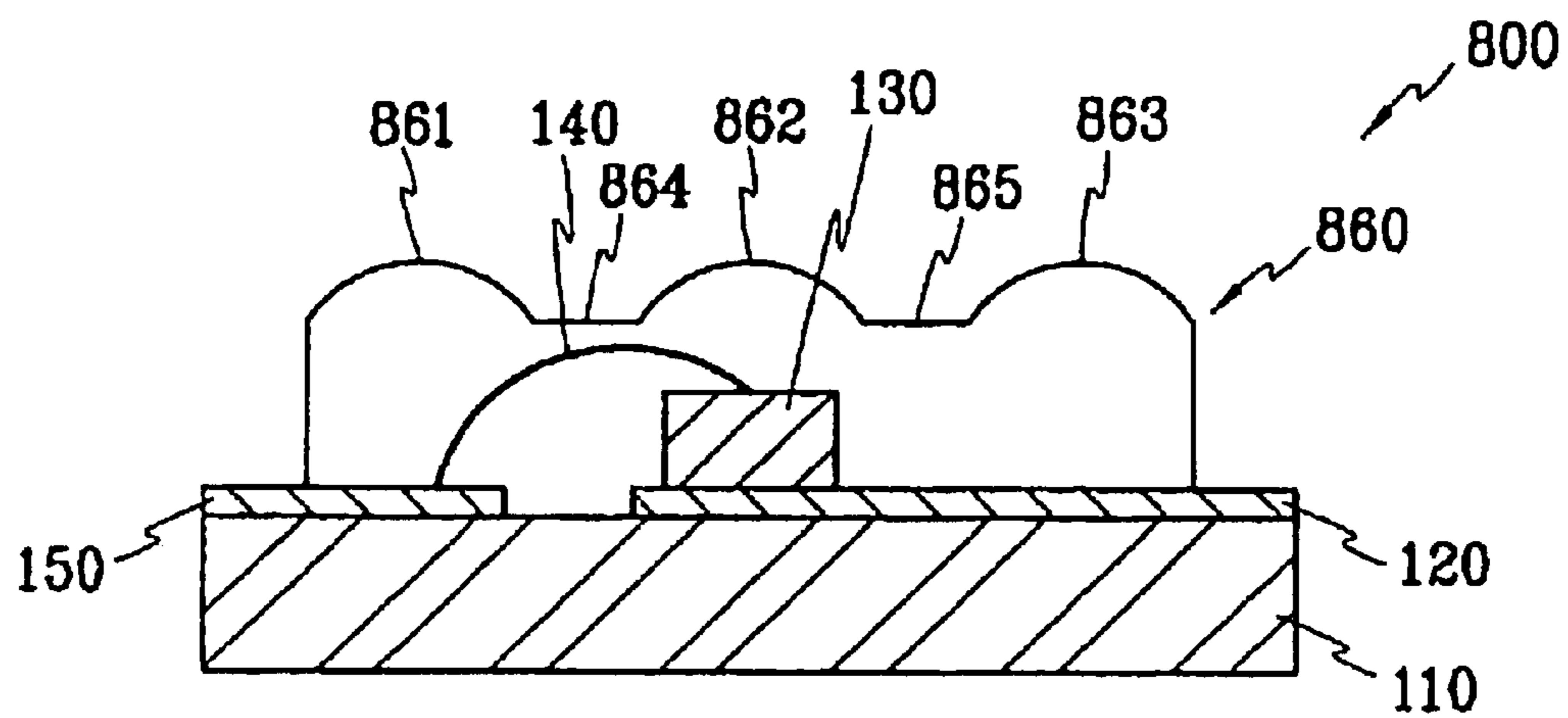
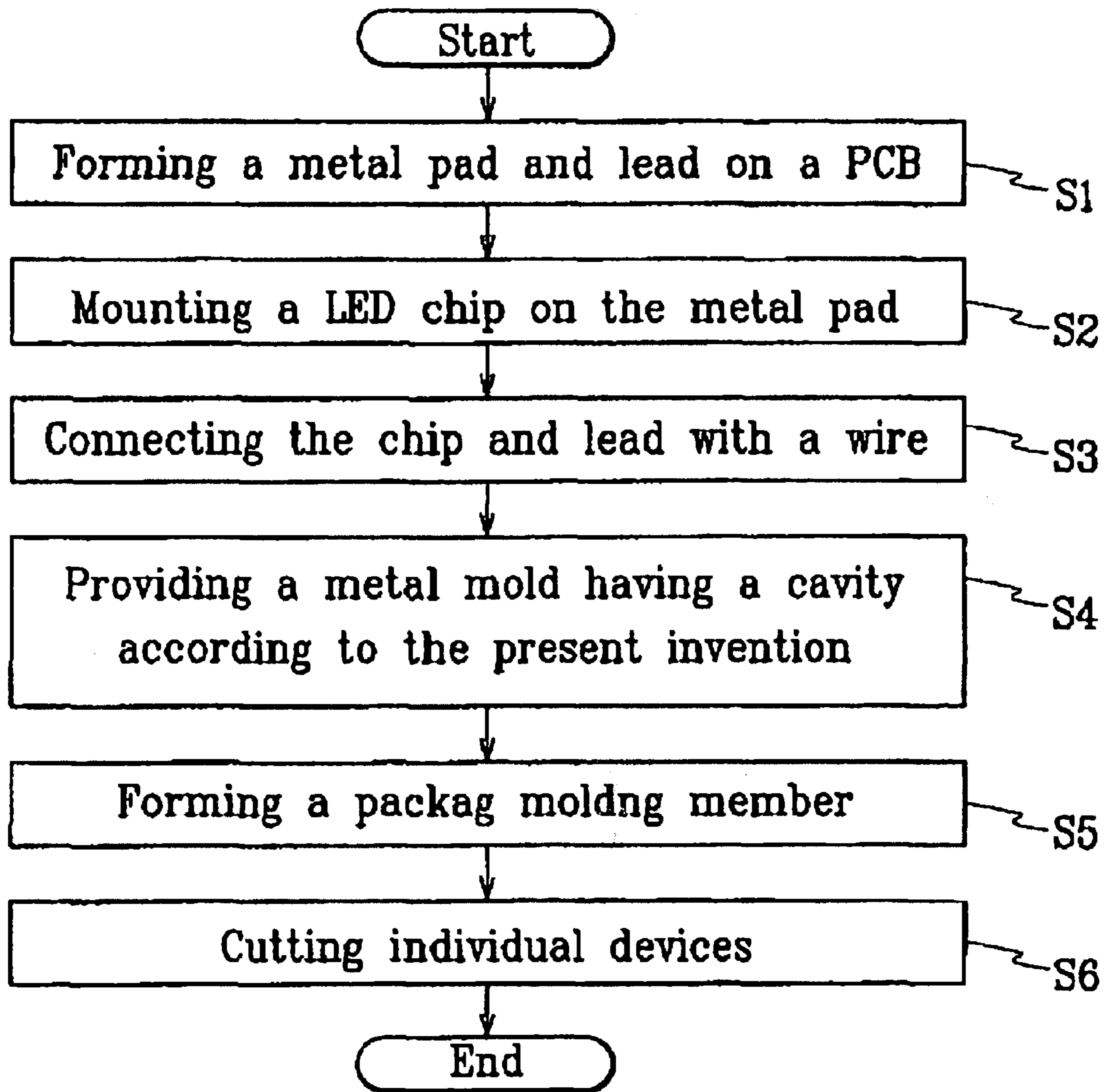

FIG.12



CHIP LIGHT EMITTING DIODE AND FABRICATION METHOD THEREOF

Matter enclosed in heavy brackets [] appears in the original patent but forms no part of this reissue specification; matter printed in italics indicates the additions made by reissue.

BACKGROUND OF THE INVENTION

(a) Field of the Invention

The present invention relates to a chip light emitting diode and a fabrication method thereof.

(b) Description of the Related Art

Chip light emitting diodes (LEDs) are generally employed as display devices and for backlighting. Recently, their use range has been increased to include various applications such as light sources for mobile phones and personal digital assistants (PDAs).

Referring to FIG. 1, a conventional chip LED **50** is provided with a metal pad **52** and a lead **55** on a printed circuit board (PCB) **51**. A light emitting chip **53** mounted on the metal pad **52** is connected to the lead **55** via a wire **54**. A resin package **56** is formed of an epoxy mold compound (EMC), and seals the chip **53**.

The conventional chip LED **50** has drawbacks in that optical paths of emitted light rays are limited because the resin package **56** has a rectangular cross section, causing a narrow viewing angle of the chip LED. Further, the intensity distribution of the emitted light is concentrated at the position of the chip. Therefore, many chip LEDs are required to light a certain area, resulting in high manufacturing cost in some applications such as for backlighting.

Further, heat generated from the conventional chip LED **50** during operation is concentrated in the edges, resulting in thermal or mechanical deformation of the diode.

When the thickness of the resin package is reduced for overall compactness of the conventional chip LED, a metal mold of the resin package should be more precisely formed for the edges, which may result in high manufacturing costs. Further, when the thickness of the resin package happens to be not uniform, stress may be concentrated at a thin part, so the adhesive strength is deteriorated causing poor reliability of the chip LED.

SUMMARY OF THE INVENTION

In view of the prior art described above, it is an object of the present invention to provide a chip light emitting diode (LED) having a wide viewing angle and a fabrication method thereof.

It is another object of the present invention to provide a chip LED in which the light intensity is substantially uniform on either side in order to illuminate a larger area with high brightness.

It is another object of the present invention to provide a chip LED in which the heat generated is distributed uniformly to avoid thermal and mechanical deformation and to prevent stress from centralizing on one side.

It is still another object of the present invention to provide a fabrication method of a chip LED, in which a simple metal mold structure can be employed to reduce fabrication costs.

To achieve these and other objects, as embodied and broadly described herein, a chip light emitting diode includes:

a metal pad and a lead spaced away from each other on a printed circuit board;

a light emitting chip mounted on the metal pad;
a wire connecting the light emitting chip and the lead; and
a resin package sealing the light emitting chip and at least a part of the metal pad, the lead, and the wire, the resin package having at least one curved projecting part.

The curved projecting part has a cross section which is substantially semicircular, or substantially or partially elliptical or parabolic. The curved projecting part preferably has a cross section which is comprised of a plurality of straight lines, an angle being formed between adjacent lines.

According to another aspect of the present invention, a fabrication method of a chip light emitting diode comprises the steps of:

mounting a light emitting chip on a metal pad formed on a printed circuit board;

connecting the light emitting chip to a lead formed on the printed circuit board;

providing the printed circuit board within a mold having a cavity, the cavity corresponding to at least one projecting part of the chip light emitting diode; and

forming a resin package sealing the light emitting chip and at least a part of the metal pad and lead by injecting resin material into the cavity of the mold, the resin package having at least one curved projecting part.

Both the foregoing general description and the following Detailed Description are exemplary and are intended to provide further explanation of the invention as claimed.

BRIEF DESCRIPTION OF THE DRAWINGS

The accompanying drawings provide a further understanding of the invention and, together with the Detailed Description, explain the principles of the invention. In the drawings:

FIG. 1 is a perspective view of a conventional chip light emitting diode;

FIG. 2 is a perspective view of a chip light emitting diode according to a first preferred embodiment;

FIG. 3 is an enlarged sectional view taken along lines A—A of FIG. 2;

FIGS. 4a and 4b shows characteristics of viewing angle according to the chips of FIG. 2 and FIG. 1, respectively;

FIGS. 5 to 7 show other examples of the resin package in the chip light emitting diodes according to the first preferred embodiment;

FIG. 8 is a perspective view of a chip light emitting diode according to a second preferred embodiment;

FIG. 9 is a sectional view along lines A—A of FIG. 8;

FIGS. 10 and 11 show other examples of the resin package in the chip light emitting diodes according to the second preferred embodiment; and

FIG. 12 shows a flow chart illustrating a fabricating method of a chip light emitting diode according to the present invention.

DETAILED DESCRIPTION OF THE PREFERRED EMBODIMENTS

The present invention will be described in detail with reference to the accompanying drawings.

Referring to FIGS. 2 and 3, a chip light emitting diode (LED) **100** according to a first preferred embodiment of the present invention has a metal pad **120** and a lead **150** provided on a printed circuit board (PCB) **110**, and a light emitting chip **130** mounted on the metal pad **120**. The metal pad

120 is made of an electrically conductive material, and the chip **130** may be suitably selected from among light emitting chips of wavelengths ranging from infrared to ultraviolet. A wire **140** connects the light emitting chip **130** to the lead **150**, and a resin package is formed protruding from the PCB **110** to seal the chip **130** and parts of the lead **150** and metal pad **120**.

The resin package **160** has a curved projecting part **161** which has a cross section that is substantially semicircular. The cross section is elongated to form a cylindrical outer surface of the resin package **160**. A suitable epoxy resin may be injected and molded into the resin package **160** using a metal mold (not shown) with a curved cavity.

Light rays **R** emitted by the chip **130** are refracted on the gently curved surface with different refractive angles. This causes light intensity distribution to become uniform and the viewing angle to be wide.

As shown in the enlarged sectional view of FIG. 3, the surface of the resin package **160** may have fine striations to scatter light emitted from the chip **130**. The striations may be formed with a triangular shape, a sinusoidal wave shape, or another suitable shape. The period **p** of the striations preferably ranges from about 0.5 μm to 1.0 μm . The striations may scatter the light emitted by the chip **130** during refraction on the surface of the resin package **160** to further widen the viewing angle.

As shown in FIGS. 4A and 4B, in which the viewing angles of the chip LED **100** according to the present invention and the conventional chip LED **50** are respectively shown, the chip LED **100** has a viewing angle ranging about 160° from H(a) to H(b) shown in a bold line, while the conventional chip LED **50** has a viewing angle ranging about 120° from H(a') to H(b'), under the same experimental conditions. Therefore, it is noted that the viewing angle of the chip LED **100** according to the present invention is enhanced by about **400** with respect to the conventional chip LED **50**.

The resin package **160** of the chip LED **100** has no sharp edge, but rather it has a gently curved surface without limitation of the light path. This causes the light efficiency to be increased, as confirmed by experimental results shown in TABLE 1 which were obtained by the inventors through many experiments. TABLE 1 shows only average values of the light intensity and brightness according to the chip LED **100** and the conventional chip LED **50**.

TABLE 1

	Average light intensity (mcd)	Average Brightness (cd/m ²)
Chip LED according to the first preferred embodiment	26	980
Conventional ship LED	20	700

The experimental results of TABLE 1 were measured under the condition that the light emitting chips **100**, **50** had the same dimensions of 304 μm in width, 304 μm in depth, and 100 μm in height, and input currents of 5 mA in light intensity measurement and 15 mA in brightness measurement.

Referring to TABLE 1, the chip LED **100** according to the present invention is enhanced in light intensity by 6 mcd and in brightness by 280 cd/m² on average with respect to the conventional chip LED **50**. Therefore, it is noted that the chip LED **100** has more light efficiency than the conventional one.

The curved projecting part **161** of the resin package **160** is described having a cross section of a semicircle referring to

FIGS. 2 and 3, but it is not limited thereto. The cross section of the curved projecting part **161** may be variably modified. FIGS. 5 to 7 shows examples of chip LEDs having resin packages of various cross sections.

Referring now to FIG. 5, the chip LED **200** has a resin package **260**. The resin package **260** has a curved projecting part **261** which has a cross section that is substantially semicircular, similar to that of FIG. 2 or FIG. 3. Further, the cross section of the curved projecting part **261** is comprised of a plurality of straight lines with an angle θ formed between adjacent lines. The angle θ may be the same over the entire curvature, or different depending on location. The cross section is elongated to form a cylindrical outer surface of the resin package **260**. The resin package **260** may serve a similar function as the resin package **160** according to the first preferred embodiment.

Referring to FIG. 6, a resin package **360** of a chip LED **300** has a stepped part **390** along edges on the elongated sides. The resin package **360** has a curved projecting part **361** to serve a similar function as the resin package **160** according to the first preferred embodiment. Although one stepped part is formed on each side in FIG. 6, it is possible to provide two or more stepped parts on each side as necessary.

It is also possible to provide a chip LED **400** with a resin package **460**, as shown in FIG. 7, whose upper surface is curved while side surfaces thereof are flat.

The present invention is not limited to the above-described embodiments. A curved projecting part of the resin package may have a cross section that is partly elliptical, parabolic, or circular, or any modification thereof. A surface of the resin package may have fine striations to scatter light, resulting in further widening of the range of viewing angle.

The resin package according to the present invention may be easily adapted to chip LEDs having a two-top structure.

Referring next to FIGS. 8 and 9, a chip LED **600** according to a second preferred embodiment of the present invention will be described. The chip LED **600** is similar to the chip LED **100** according to the first preferred embodiment, except the shape of a resin package **660**.

The resin package **660** of the chip LED **600** has two curved projecting parts **661**, **662**. Both curved projecting parts **661**, **662** are spaced out by spacer **663** with an interval **1** therebetween. The interval **1** may be selected from a range of 0.1 to 0.4 times the bottom length **b** in the cross section.

In the chip LED **600** according to the second preferred embodiment, light rays emitted by the chip **130** are transmitted and refracted on the two curved surface of the projecting parts **661** and **662**. Then, the refracted rays diverge to provide a large viewing angle. This may enhance the lighting effect of both sides on a predetermined area.

Although the resin package **660** of the chip LED **600** according to the second preferred embodiment is described to have two projecting parts **661**, **662**, it is also possible to form more than two projecting parts in a resin package.

FIGS. 10 and 11 show other examples of the resin package. A chip LED **700** of FIG. 10 has a resin package **760** with two projecting parts **761**, **762** which are formed adjacent to each other without any spacer. A chip LED **800** having a resin package **860** is shown in FIG. 11. Three projecting parts **861**, **862**, **863** are formed with two spacers **864**, **865**.

Light rays emitted by the chip **130** in the chip LED **700** or **800** are transmitted and refracted in the projecting parts **661**, and they diverge with a large viewing angle. This may

5

enhance the lighting effect as compared to the conventional chip LED **50** in FIG. **1**.

It is also possible that the surface of the resin package according to the second preferred embodiment may have fine striations to scatter light, resulting in further widening of the range of viewing angle.

Referring next to FIG. **12** with FIG. **2**, a fabrication method of a chip LED will be described. First, the metal pad **120** and lead **150** are formed on the PCB **110** (S1). The chip **130** is mounted on the metal pad **120** and then connected to the lead **150** with the wire **140** (S2–S3). The chip **130** may be suitably selected from among light emitting chips of a desired wavelength.

The PCB **110** is then mounted on a mold having a cavity (S4). The cavity corresponds to the projecting part(s) according to one of the first preferred embodiment and the second preferred embodiment.

Next, a solid epoxy mold compound is heated to 170–1800 and injected into the mold. The resin package **160** is formed on the PCB **110** with the shape described in the first or second preferred embodiment (S5). The resin package is formed to seal the light emitting chip. It is possible that the resin package is formed to seal either a part of the metal pad and lead, or the entire surface of the metal pad and lead.

Practically, a plurality of chip LEDs are formed on one PCB, which for example has a size of about 80 mm×50 mm. Therefore, each chip LED on the PCB is individually cut off (S6).

As described above, light rays emitted from the light emitting chip diverge radially and uniformly in a chip LED according to the present invention, to further widen the viewing angle. The lighting efficiency of the chip LED is also improved, so the number of chip LEDs is reduced in application to backlighting to light a certain area.

Heat generated from the chip LED according to the present invention is also uniformly distributed on the surface, to prevent the chip LED from deforming thermally or mechanically. Further, stress is not concentrated on one side, to enhance the adhesive characteristics between the resin package and the PCB, especially in compact chip LEDs.

Since a mold with a curved projecting part is easily manufactured, as compared to a resin package with a rectangular cross section, a relatively simple mold structure for a resin package reduces fabrication costs.

It will be apparent to those skilled in the art that various modifications and variations can be made to the device and method of the present invention without departing from the spirit and scope of the invention. The present invention covers the modifications and variations of this invention provided they come within the scope of the appended claims and their equivalents.

What is claimed is:

1. A chip light emitting diode comprising:

a metal pad and a lead spaced away from each other on a printed circuit board;

a light emitting chip mounted on the metal pad;

a wire connecting the light emitting chip and the lead; and

a resin package sealing the light emitting chip and at least a part of the metal pad, lead, and the wire, the resin package having at least one curved projecting part, the at least one curved projecting part having a cross section elongated along the printed circuit board,

wherein the cross section of the curved projecting part is comprised of a plurality of straight lines with an angle formed between adjacent lines.

6

2. A chip light emitting diode as recited in claim **1**, wherein the cross section of the curved projecting part is substantially semicircular, or substantially or partially elliptical or parabolic.

3. A chip light emitting diode as recited in claim **1**, wherein at least one stepped part is formed at an outer edge of the resin package.

4. A chip light emitting diode as recited in claim **1**, wherein the surface of the resin package has fine striations to scattering light emitted from the light emitting chip.

5. A chip light emitting diode as recited in claim **1**, wherein the resin package has one projecting part.

6. A chip light emitting diode as recited in claim **1**, wherein the resin package has two projecting parts which are spaced away from each other by a predetermined interval, wherein the predetermined interval ranges from 0.1 to 0.4 times a bottom length of the resin package.

7. A chip light emitting diode comprising:

a metal pad and a lead spaced away from each other on a printed circuit board;

a light emitting chip mounted on the metal pad;

a wire connecting the light emitting chip and the lead; and

a resin package sealing the light emitting chip and at least a part of the metal pad, lead, and the wire, the resin package having at least one curved projecting part, the at least one curved projecting part having a cross-section elongated along the printed circuit board and wherein at least one stepped part is formed at an outer edge of the resin package.

8. A chip light emitting diode as recited in claim **7**, wherein the cross-section of the curved projecting part is substantially semicircular, or substantially or partially elliptical or parabolic.

9. A chip light emitting diode as recited in claim **7**, wherein the surface of the resin package has fine striations to scatter light emitted from the light emitting chip.

10. A chip light emitting diode as recited in claim **7**, wherein the resin package has one projecting part.

11. A chip light emitting diode as recited in claim **7**, wherein the resin package has two projecting parts which are spaced away from each other by a predetermined interval;

wherein the predetermined interval ranges from 0.1 to 0.4 times a bottom length of the resin package.

12. A chip light emitting diode comprising:

a metal pad and a lead spaced away from each other on a printed circuit board;

a light emitting chip mounted on the metal pad;

a wire connecting the light emitting chip and the lead; and

a resin package sealing the light emitting chip and at least a part of the metal pad, lead, and the wire, the resin package having at least one curved projecting part, the at least one curved projecting part having a cross-section elongated along the printed circuit board and wherein the surface of the resin package has fine striations to scatter light emitted from the light emitting chip.

13. A chip emitting diode as recited in claim **12**, wherein the cross-section of the curved projecting part is substantially semicircular, or substantially or partially elliptical or parabolic.

14. A chip emitting diode as recited in claim **12**, wherein the resin package has two projecting parts which are spaced away from each other by a predetermined interval;

wherein the predetermined interval ranges from 0.1 to 0.4 times a bottom length of the resin package.

7

15. A chip light emitting diode comprising:
 a metal pad and a lead spaced away from each other on a
 printed circuit board;
 a light emitting chip mounted on the metal pad;
 a wire connecting the light emitting chip and the lead;
 and
 a resin package sealing the light emitting chip and at least
 a part of the metal pad, lead, and the wire, the resin
 package having at least one curved projecting part, the
 at least one curved projecting part having a cross-
 section elongated along the printed circuit board;
 wherein the resin package has two projecting parts which
 are spaced away from each other by a predetermined
 interval; and
 wherein the predetermined interval ranges from 0.1 to 0.4
 times a bottom length of the resin package.
16. A chip emitting diode as recited in claim 15, wherein
 the cross-section of the curved projecting part is substan-
 tially semicircular, or substantially or partially elliptical or
 parabolic.
17. A chip light emitting diode as recited in claim 15,
 wherein the resin package has one projecting part.
18. A chip light emitting diode comprising:
 a metal pad and a lead spaced away from each other on a
 printed circuit board;
 a light emitting chip mounted on the metal pad;
 a wire connecting the light emitting chip and the lead; and
 a resin package sealing the light emitting chip and at least
 a part of the metal pad, lead, and the wire, the resin
 package having at least one curved projecting part, the
 at least one curved projecting part having a cross-
 section elongated along the printed circuit board and
 wherein one stepped part is formed at an outer edge of
 the resin package.
19. A chip light emitting diode as recited in claim 18,
 wherein the cross-section of the curved projecting part is
 substantially semicircular, or substantially or partially ellip-
 tical or parabolic.
20. A chip light emitting diode as recited in claim 18,
 wherein the surface of the resin package has fine striations to
 scatter light emitted from the light emitting chip.
21. A chip light emitting diode as recited in claim 18,
 wherein the resin package has one projecting part.
22. A chip light emitting diode as recited in claim 18,
 wherein the resin package has two projecting parts which
 are spaced away from each other by a predetermined inter-
 val;
 wherein the predetermined interval ranges from 0.1 to 0.4
 times a bottom length of the resin package.
23. A chip light emitting diode comprising:
 a metal pad and a lead spaced away from each other on a
 printed circuit board;
 a light emitting chip mounted on the metal pad;
 a wire connecting the light emitting chip and the lead;
 a resin package sealing the light emitting chip and at least
 a part of the metal pad, lead, and the wire, the resin
 package having at least one curved projecting part, the
 at least one curved projecting part having a cross-
 section elongated along the printed circuit board and
 wherein the cross-section of the curved projecting part
 is substantially semicircular, or substantially or par-
 tially elliptical or parabolic and at least one stepped
 part being formed at an outer edge of the resin package.
24. A chip light emitting diode as recited in claim 23,
 wherein the surface of the resin package has fine striations to
 scatter light emitted from the light emitting chip.

8

25. A chip light emitting diode as recited in claim 23,
 wherein the resin package has one projecting part.
26. A chip light emitting diode as recited in claim 23,
 wherein the resin package has two projecting parts which
 are spaced away from each other by a predetermined inter-
 val;
 wherein the predetermined interval ranges from 0.1 to 0.4
 times a bottom length of the resin package.
27. A chip light emitting diode comprising:
 a metal pad and a lead spaced away from each other on a
 printed circuit board;
 a light emitting chip mounted on the metal pad;
 a wire connecting the light emitting chip and the lead; and
 a resin package sealing the light emitting chip and at least
 a part of the metal pad, lead, and the wire, the resin
 package having at least one curved projecting part, the
 at least one curved projecting part having a cross-
 section elongated along the printed circuit board
 wherein at least one stepped part is formed at an outer
 edge of the resin package and wherein the surface of the
 resin package has fine striations to scatter light emitted
 from the light emitting chip.
28. A chip light emitting diode as recited in claim 27,
 wherein the cross-section of the curved projecting part is
 substantially semicircular, or substantially or partially ellip-
 tical or parabolic.
29. A chip light emitting diode as recited in claim 27,
 wherein the resin package has one projecting part.
30. A chip light emitting diode as recited in claim 27,
 wherein the resin package has two projecting parts which
 are spaced away from each other by a predetermined inter-
 val;
 wherein the predetermined interval ranges from 0.1 to 0.4
 times a bottom length of the resin package.
31. A chip light emitting diode comprising:
 a metal pad and a lead spaced away from each other on a
 printed circuit board;
 a light emitting chip mounted on the metal pad;
 a wire connecting the light emitting chip and the lead;
 a resin package sealing the light emitting chip and at least
 a part of the metal pad, lead, and the wire, the resin
 package having at least one curved projecting part, the
 at least one curved projecting part having a cross-
 section elongated along the printed circuit board,
 wherein at least one stepped part is formed at an outer
 edge of the resin package and wherein the resin pack-
 age has two projecting parts which are spaced away
 from each other by a predetermined interval.
32. A chip light emitting diode as recited in claim 31,
 wherein the cross-section of the curved projecting part is
 substantially semicircular, or substantially or partially ellip-
 tical or parabolic.
33. A chip light emitting diode as recited in claim 31,
 wherein the surface of the resin package has fine striations to
 scatter light emitted from the light emitting chip.
34. A chip light emitting diode as recited in claim 31,
 wherein the predetermined interval ranges from 0.1 to 0.4
 times a bottom length of the resin package.
35. A chip light emitting diode comprising:
 a metal pad and a lead spaced away from each other on a
 printed circuit board;
 a light emitting chip mounted on the metal pad;
 a wire connecting the light emitting chip and the lead; and
 a resin package sealing the light emitting chip and at least
 a part of the metal pad, lead, and the wire, the resin

package having at least one curved projecting part, the at least one curved projecting part having a cross-section elongated along the printed circuit board, wherein the cross-section of the curved projecting part is substantially semicircular, or substantially or partially elliptical or parabolic, and wherein the surface of the resin package has fine striations to scatter light emitted from the light emitting chip.

36. A chip light emitting diode comprising:

a metal pad and a lead spaced away from each other on a printed circuit board;

a light emitting chip mounted on the metal pad;

a wire connecting the light emitting chip and the lead; and

a resin package sealing the light emitting chip and at least a part of the metal pad, lead, and the wire, the resin package having at least one curved projecting part, the at least one curved projecting part having a cross-section elongated along the printed circuit board, wherein the surface of the resin package has fine striations to scatter light emitted from the light emitting chip and wherein the resin package has one projecting part.

37. A chip light emitting diode comprising:

a metal pad and a lead spaced away from each other on a printed circuit board;

a light emitting chip mounted on the metal pad;

a wire connecting the light emitting chip and the lead;

a resin package sealing the light emitting chip and at least a part of the metal pad, lead, and the wire, the resin package having at least one curved projecting part, the at least one curved projecting part having a cross-

section elongated along the printed circuit board, wherein the surface of the resin package has fine striations to scatter light emitted from the light emitting chip and wherein the resin package has two projecting parts which are spaced away from each other by a predetermined interval.

38. A chip light emitting diode as recited in claim 37, wherein the predetermined interval ranges from 0.1 to 0.4 times a bottom length of the resin package.

39. A chip light emitting diode comprising:

a metal pad and a lead spaced away from each other on a printed circuit board;

a light emitting chip mounted on the metal pad;

a wire connecting the light emitting chip and the lead;

a resin package sealing the light emitting chip and at least a part of the metal pad, lead, and the wire, the resin package having at least one curved projecting part, the at least one curved projecting part having a cross-section elongated along the printed circuit board wherein the cross-section of the curved projecting part is substantially semicircular, or substantially or partially elliptical or parabolic and wherein the resin package has two projecting parts which are spaced away from each other by a predetermined interval.

40. A light emitting diode as recited in claim 39 wherein the predetermined interval ranges from 0.1 to 0.4 times a bottom length of the resin package.

* * * * *