

US00RE42085E

(19) **United States**
(12) **Reissued Patent**
Sexton

(10) **Patent Number:** **US RE42,085 E**
(45) **Date of Reissued Patent:** ***Feb. 1, 2011**

(54) **FLAT SURFACE-MOUNTED MULTI-PURPOSE WIRE**
(75) Inventor: **Robert J. Sexton**, Hendersonville, TN (US)
(73) Assignee: **Newire, Inc.**, Knoxville, TN (US)

4,185,887 A 1/1980 Ferrentino
4,219,928 A 9/1980 Kuo
4,355,865 A 10/1982 Conrad et al.
4,401,361 A 8/1983 Slaughter
4,407,065 A 10/1983 Gray
4,441,088 A 4/1984 Anderson

(Continued)

(*) Notice: This patent is subject to a terminal disclaimer.

FOREIGN PATENT DOCUMENTS

(21) Appl. No.: **11/008,750**
(22) Filed: **Dec. 10, 2004**

Related U.S. Patent Documents

Reissue of:
(64) Patent No.: **6,492,595**
Issued: **Dec. 10, 2002**
Appl. No.: **09/783,576**
Filed: **Feb. 14, 2001**

DE 2439512 A1 3/1976
EP 0116505 5/1988
GB 1028980 5/1966
GB 2252197 A 7/1992
JP 60-82883 S 12/1986
JP 61-65649 11/1987
JP 62-99147 S 1/1989
JP 62-166487 5/1989
JP 63-47080 10/1989
JP 03-27608 11/1992
JP 03-63168 H 3/1993
WO 87/06760 11/1987

U.S. Applications:

(63) Continuation of application No. 08/942,305, filed on Oct. 1, 1997, now abandoned.

(51) **Int. Cl.**
H01B 7/08 (2006.01)

(52) **U.S. Cl.** **174/117 F; 174/117 FF; 174/117 A**

(58) **Field of Classification Search** **174/117 F, 174/117 FF, 117 A; 439/652**
See application file for complete search history.

(56) **References Cited**

U.S. PATENT DOCUMENTS

3,079,458 A * 2/1963 Hedstrom 174/117 FF
3,168,617 A * 2/1965 Richter 174/117 FF
3,547,718 A 12/1970 Gordon

OTHER PUBLICATIONS

Withers, R.S. et al., "Superconductive Analog Signal Processing Devices," Proceedings of the IEEE, IEEE, New York, US, vol. 77, No. 8, Aug. 1, 1989, pp. 1247-1262.

(Continued)

Primary Examiner—Chau N Nguyen
(74) *Attorney, Agent, or Firm*—Sutherland Asbill & Brennan LLP

(57) **ABSTRACT**

A multi-purpose wire includes at least one elongated conductor having a width of at least 0.125 inches. The conductor includes at least one conductive layer having a thickness no greater than about 0.0200 inches. The wire also includes a bonding material between each conductor, and an insulation layer surrounding the conductor and bonding material.

37 Claims, 25 Drawing Sheets

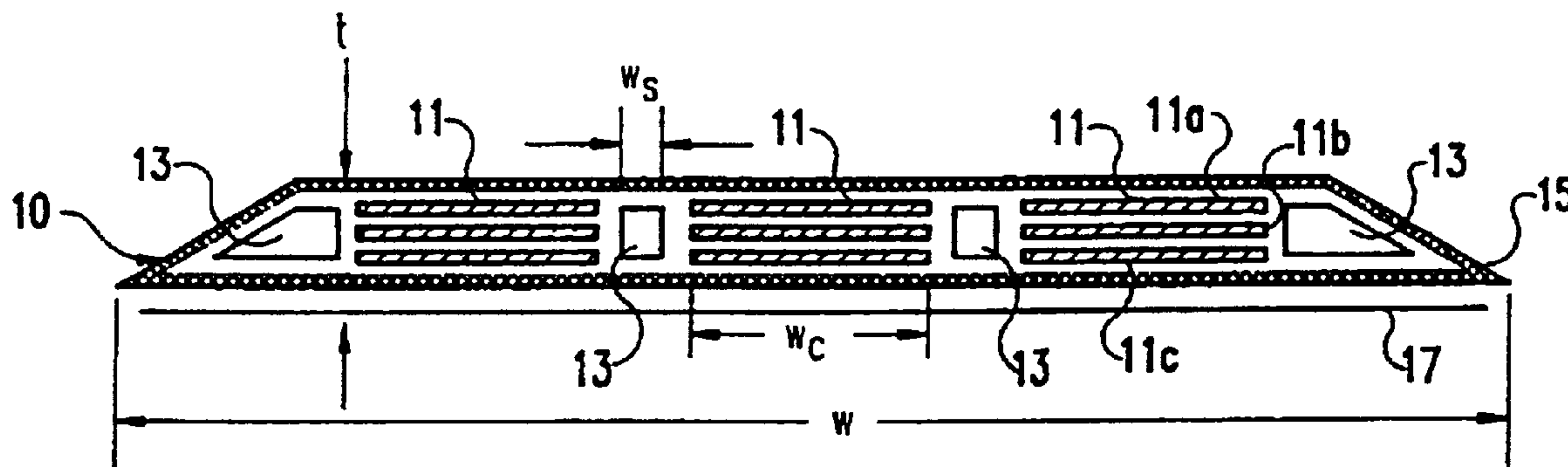

U.S. PATENT DOCUMENTS

4,616,102 A 10/1986 Noorily
 4,658,090 A 4/1987 Coon
 4,675,625 A 6/1987 Johnston
 4,845,311 A 7/1989 Schreiber et al.
 4,992,059 A 2/1991 King et al.
 5,003,273 A 3/1991 Oppenberg
 5,064,684 A 11/1991 Mir et al.
 5,068,632 A 11/1991 Champeau
 5,136,123 A 8/1992 Kobayahi et al.
 5,274,246 A 12/1993 Hopkins et al.
 5,373,109 A 12/1994 Argyrakis et al.
 5,408,053 A 4/1995 Young
 5,430,247 A 7/1995 Bockelman
 5,468,159 A 11/1995 Brodsky et al.
 5,500,489 A * 3/1996 Shah et al. 174/117 FF
 5,554,825 A 9/1996 Parker et al.
 5,673,352 A 9/1997 Bauer et al.
 5,804,768 A * 9/1998 Sexton 174/117 F
 5,847,324 A 12/1998 Farquar et al.
 5,939,952 A 8/1999 Noda et al.
 6,005,193 A 12/1999 Markel
 6,055,722 A 5/2000 Tighe et al.
 6,225,568 B1 5/2001 Lin et al.

OTHER PUBLICATIONS

Skalare, A. et al., "Slot Line Components for Millimeter Wave and Sub-Millimeter Wave Integrated Circuits," Proceedings of the European Microwave Conference. Folkets Hus, Sweden, Sep. 12-16, 1988, Tunbridge Wells, Microwave Exhibitions, GB, vol. Conf. 18, pp. 665-668.
 Declaration of Robert J. Sexton pursuant to 37 C.F.R. Section 1.132 dated Jan. 25, 2008.
 "Stealth Speaker Wire," Home Mechanix, A Times Mirror Magazine, Oct. 1994, p. 12.
 Taperwire Advertisement, Systems: Contractor News, Fall 1994.
 "Wired Up," Professional Security Installer, Nov. 1995, pp. 10-11.
 Advance Wire Solutions Web Site, available at <http://www.advancewiresolutions.com/index.htm>, accessed on Jun. 2, 2006.
 List of Taperwire Wire Models and Invoice Listings, Sep. 2001.
 Tape-R Wire, Taperwire Description and Installation Instructions, Date Unknown.
 Taperwire Price Schedules, Date Unknown.
 * cited by examiner

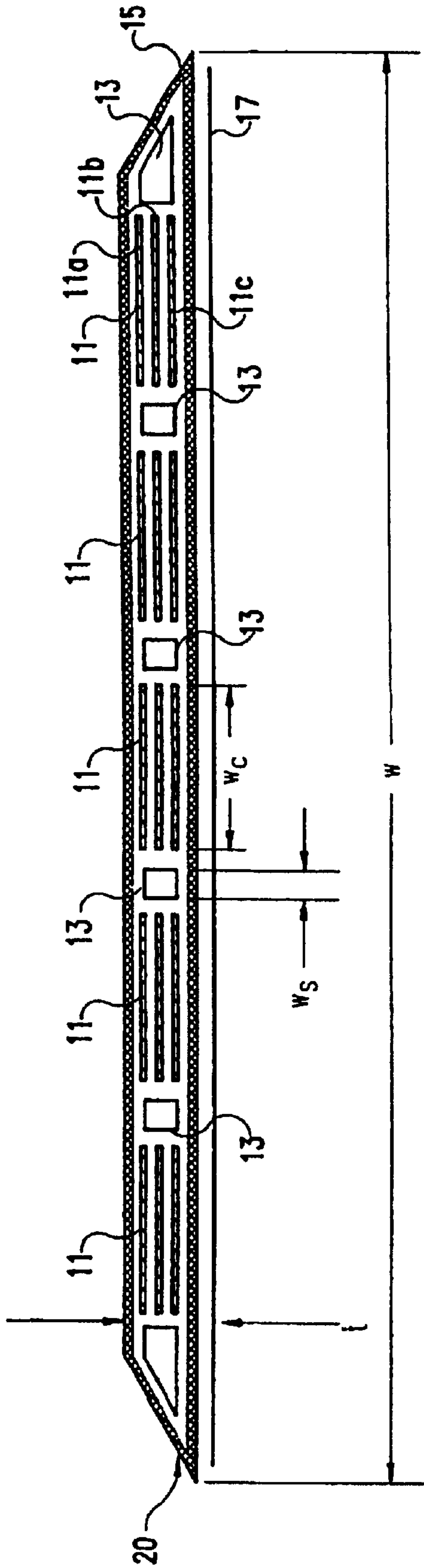

FIG. 2

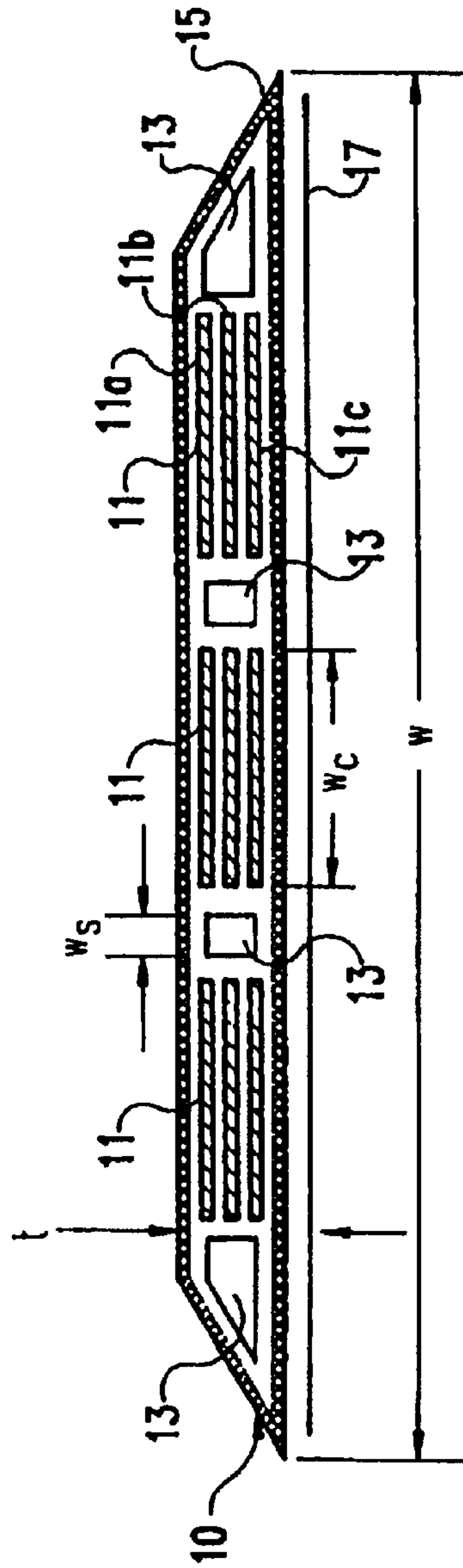

FIG. 1

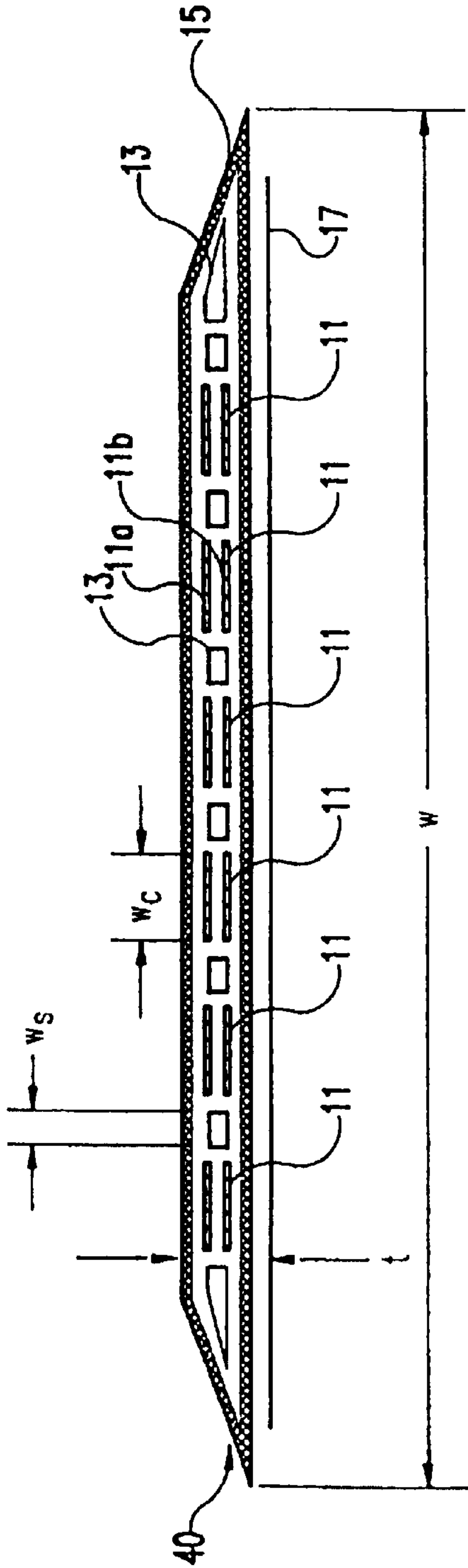

FIG. 4

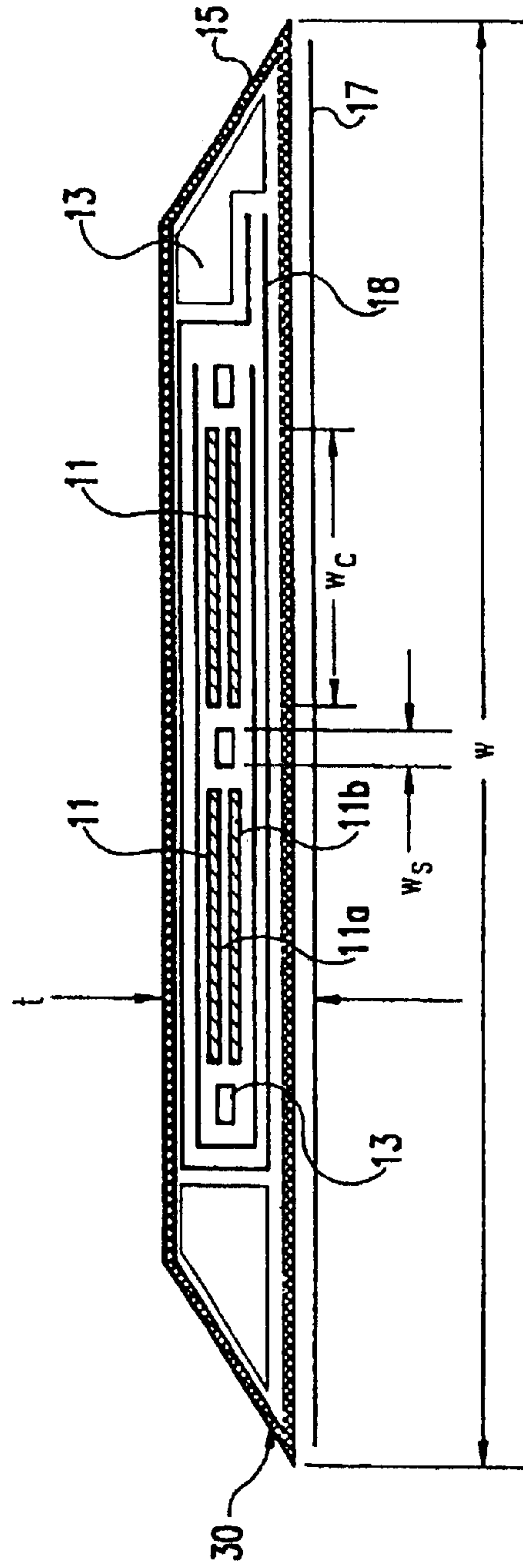

FIG. 3

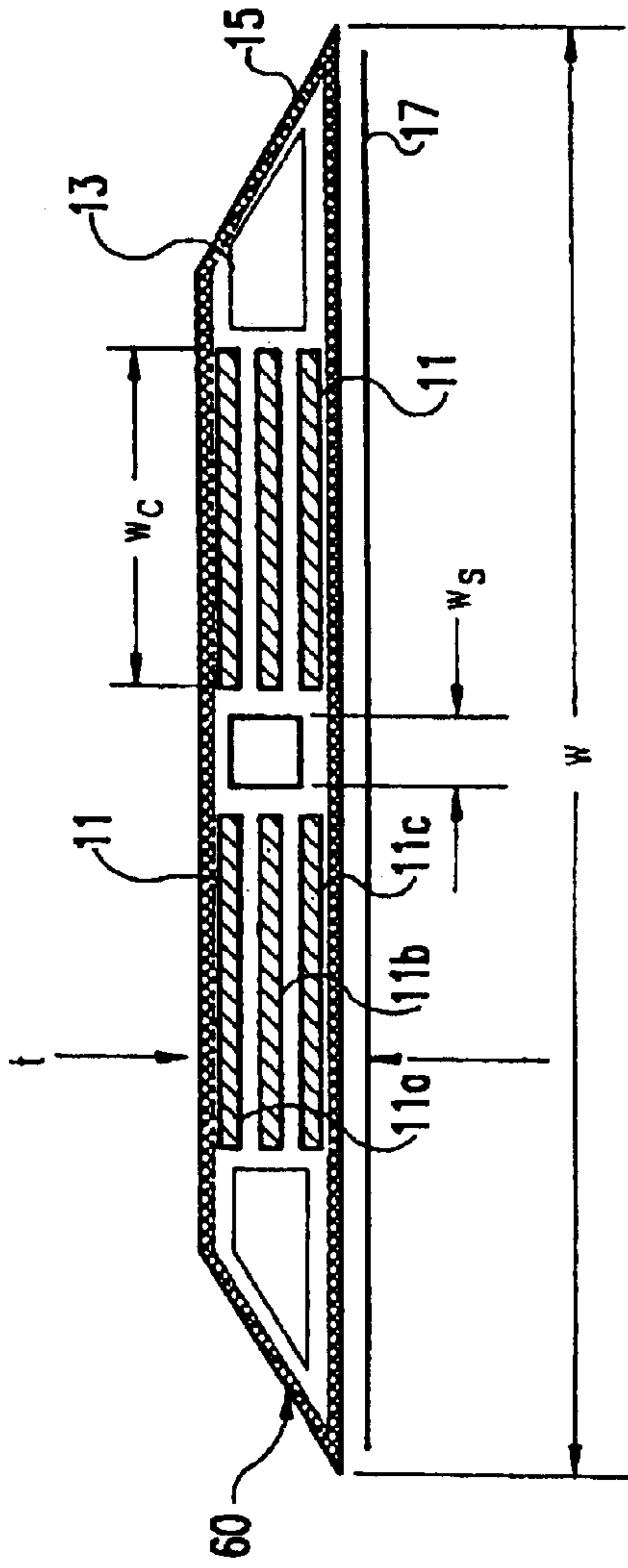

FIG. 6

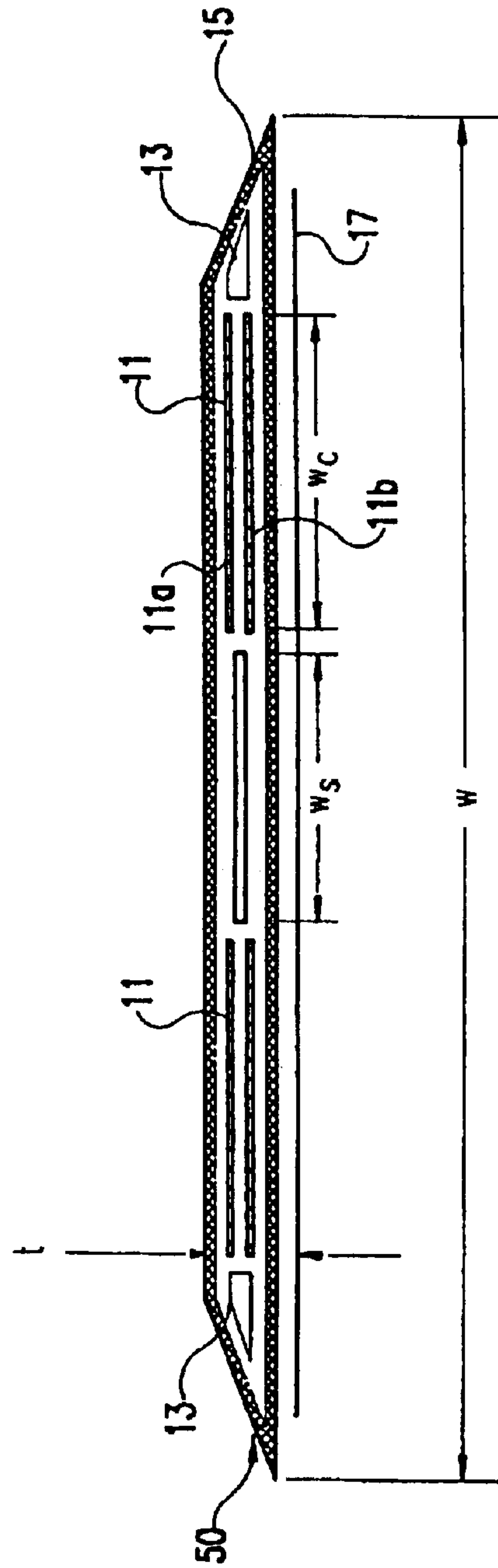

FIG. 5

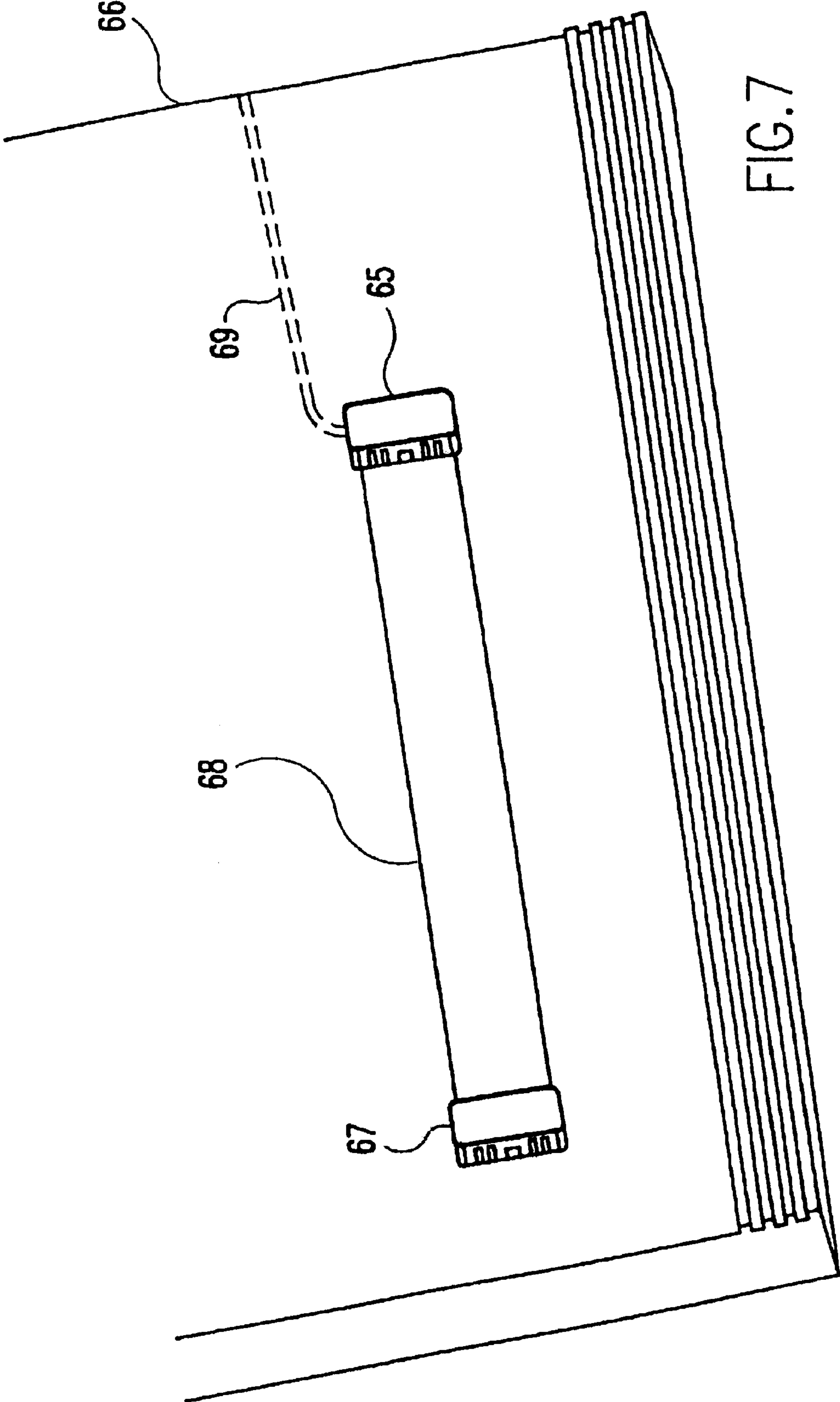

FIG. 7

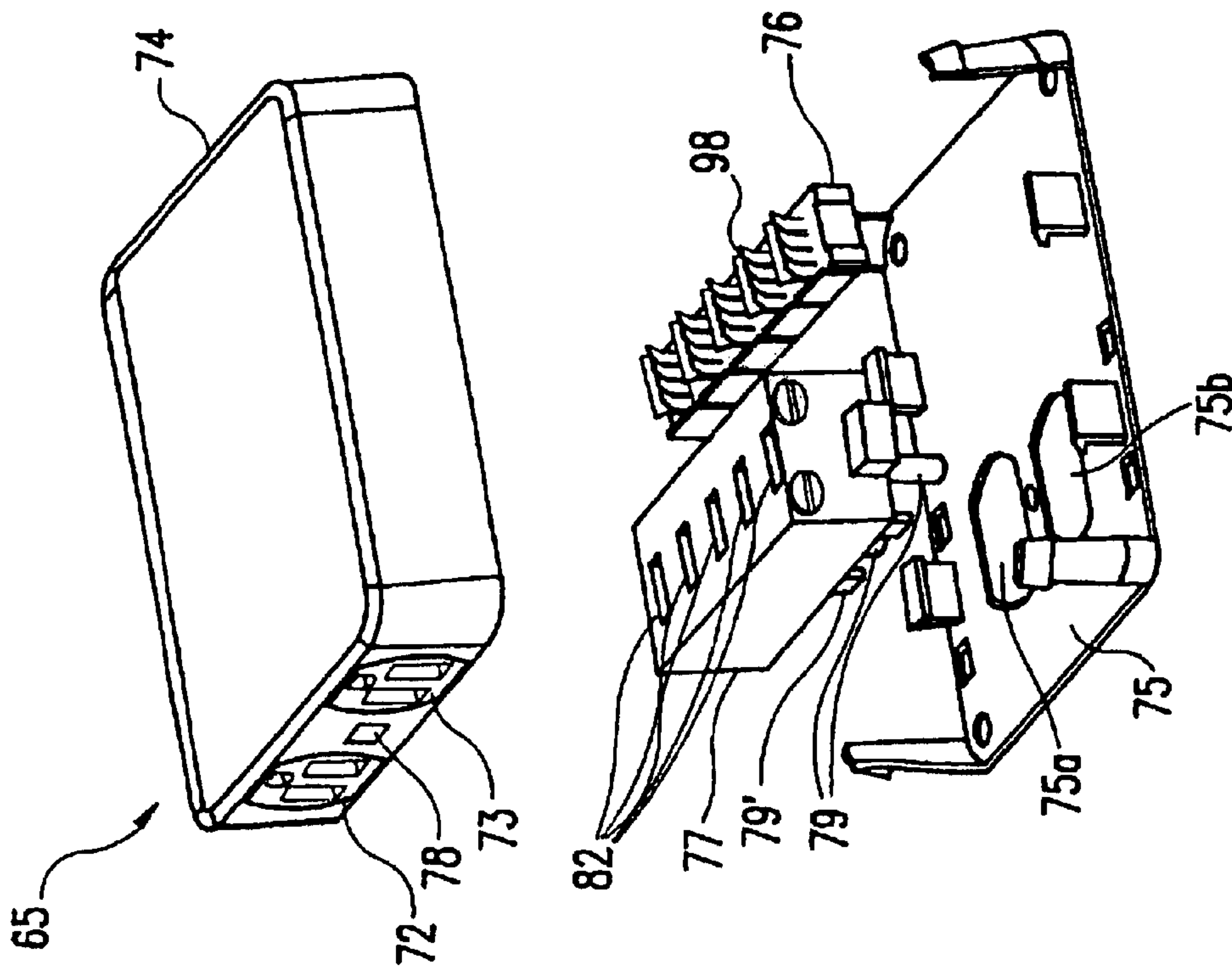

FIG.8A

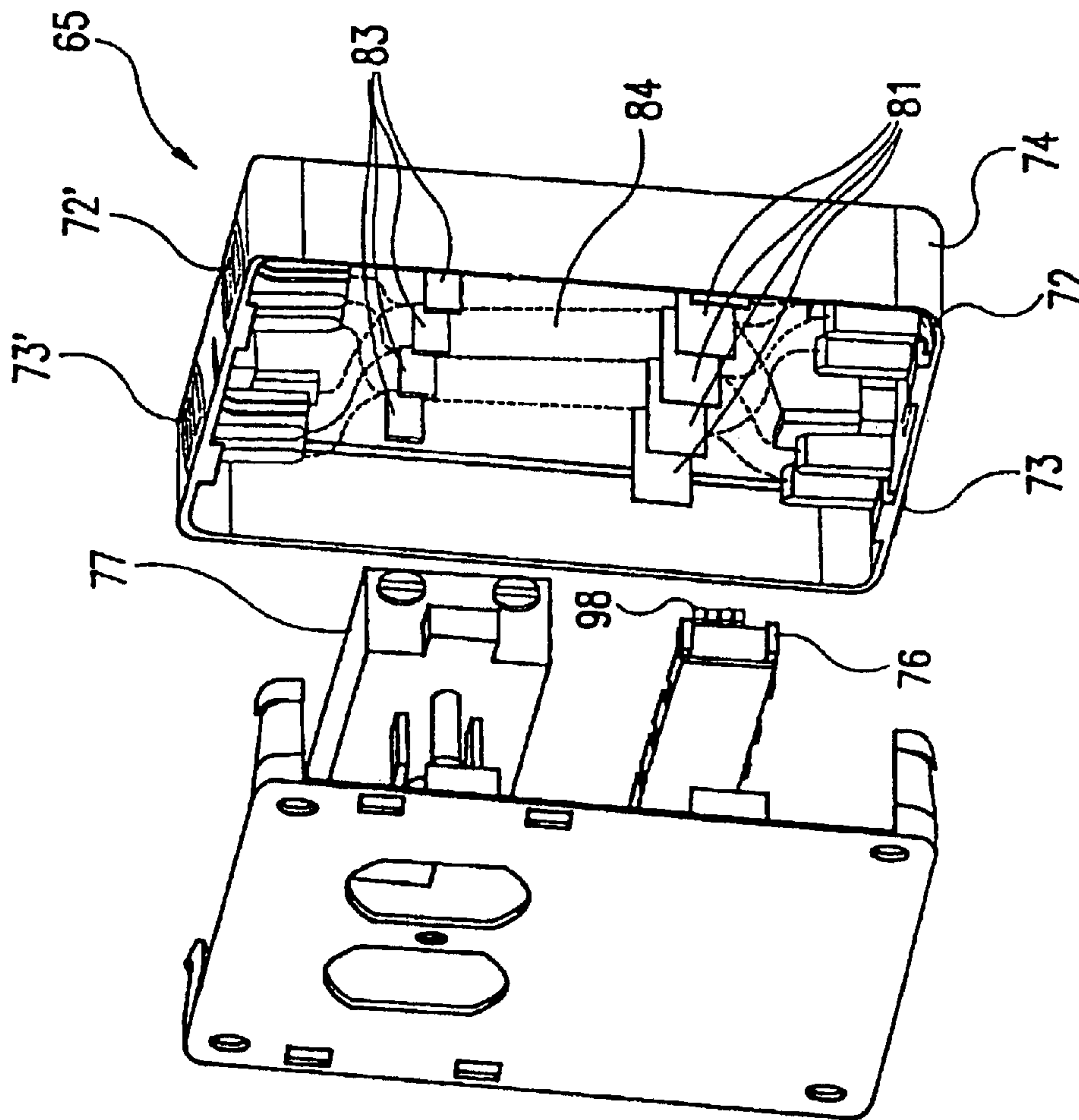

FIG.8B

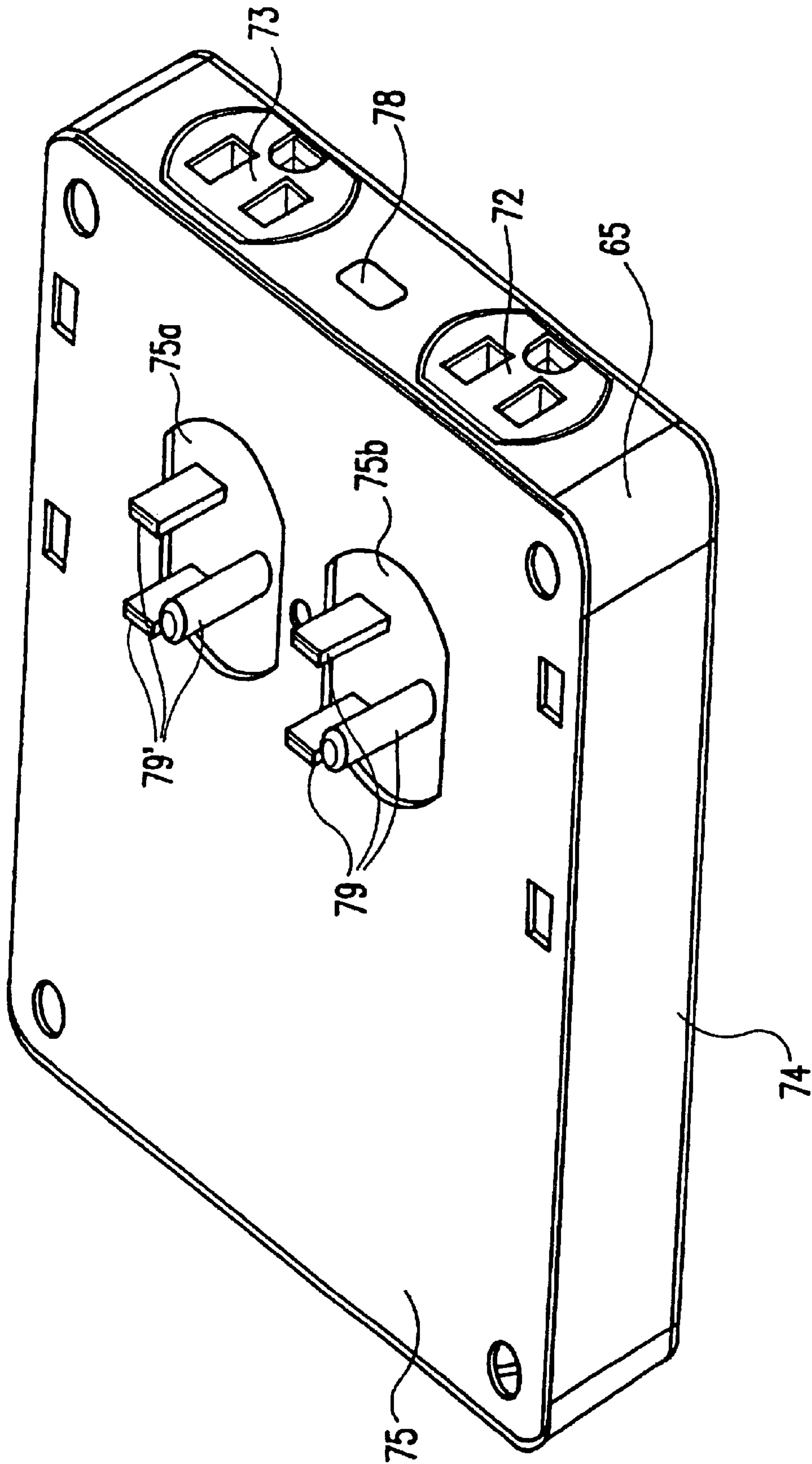

FIG. 8C

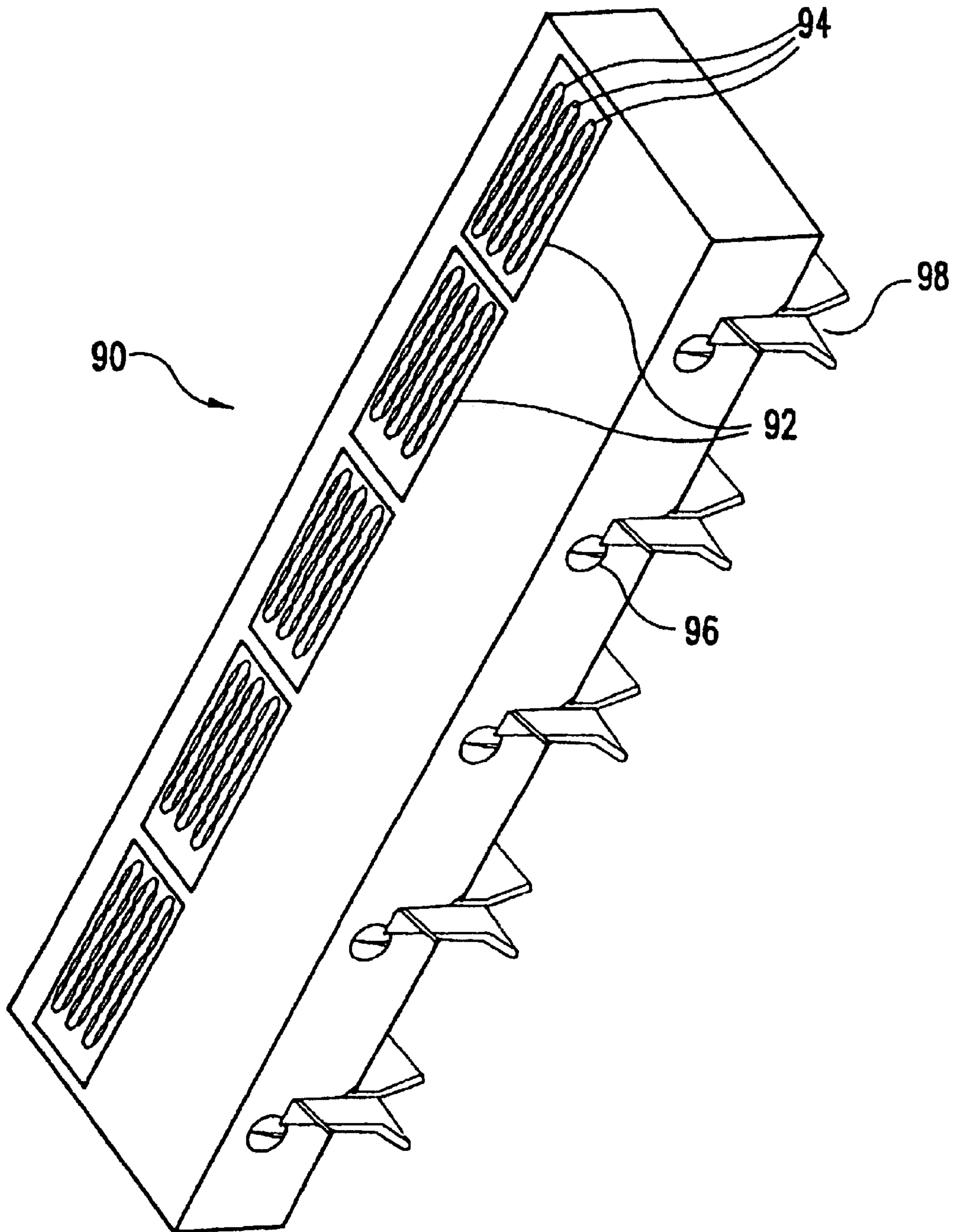

FIG.9A

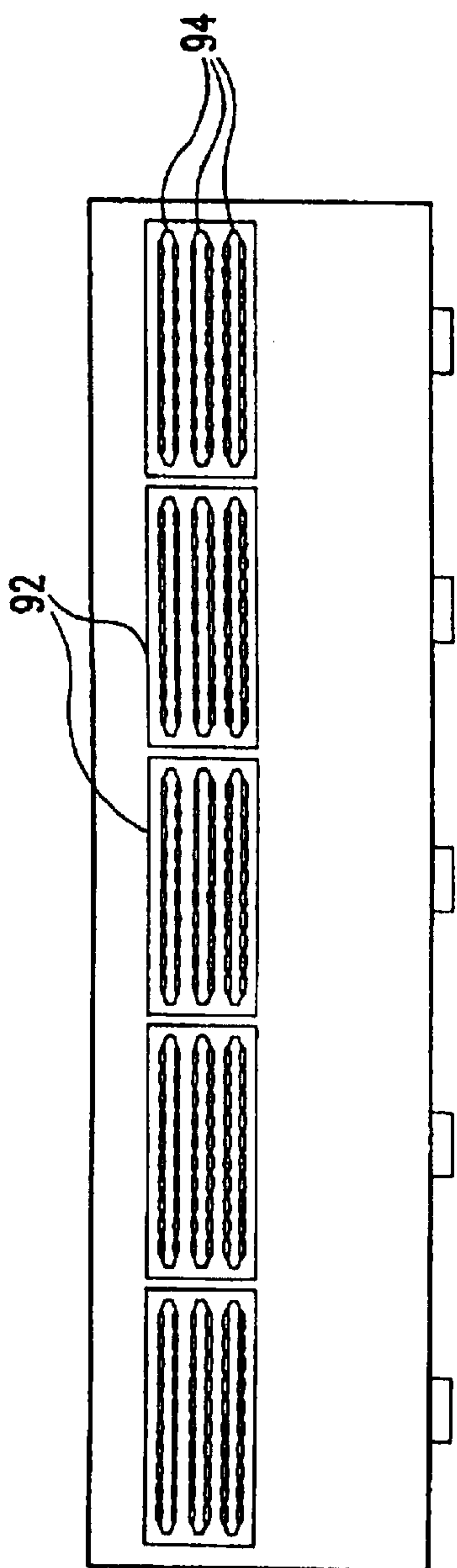

FIG. 9B

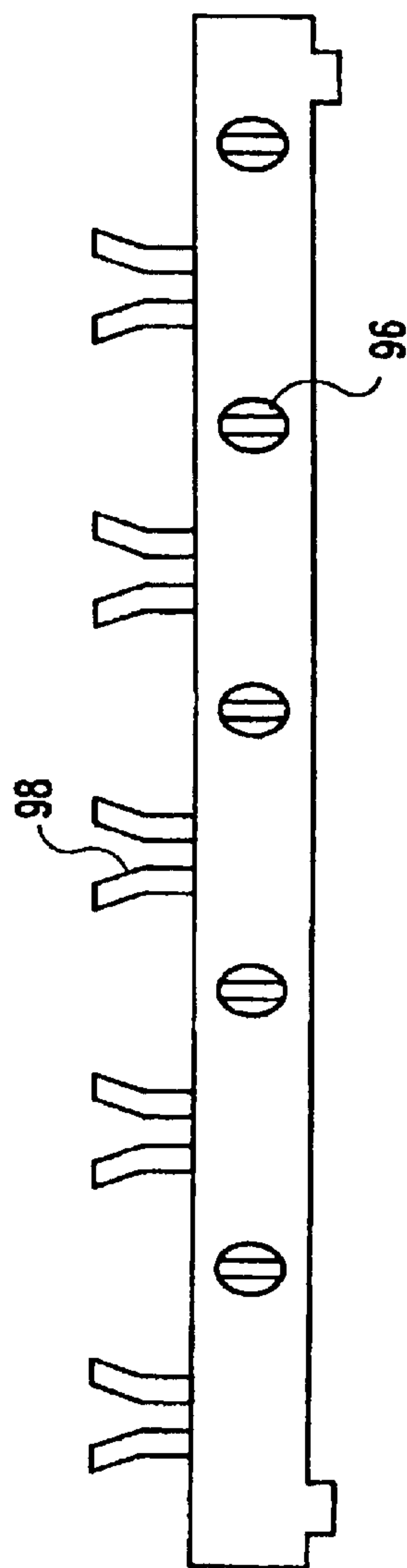

FIG. 9C

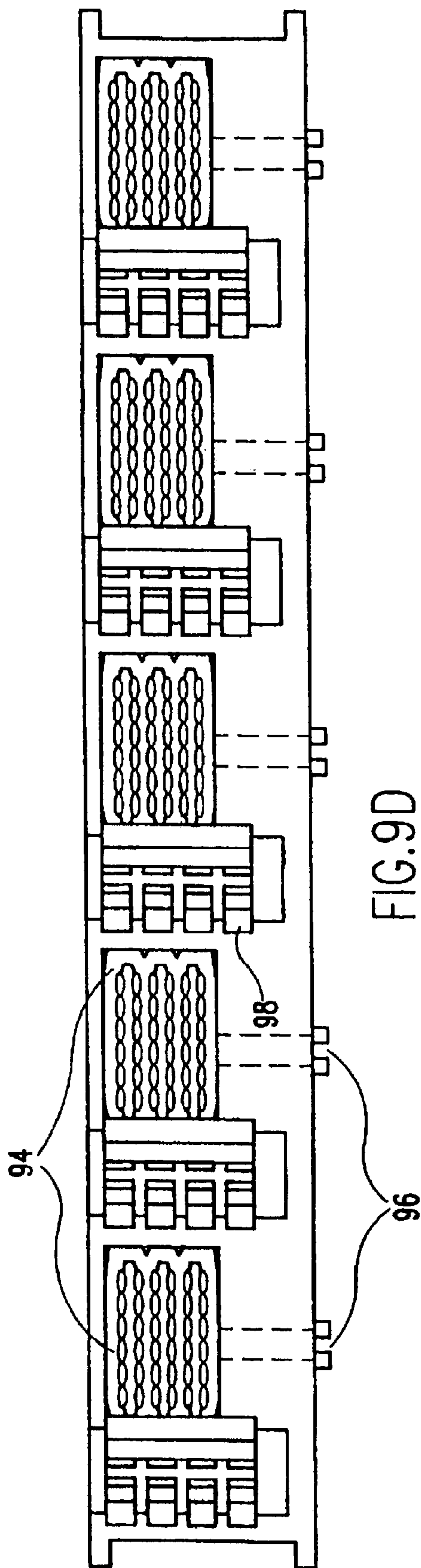

FIG. 9D

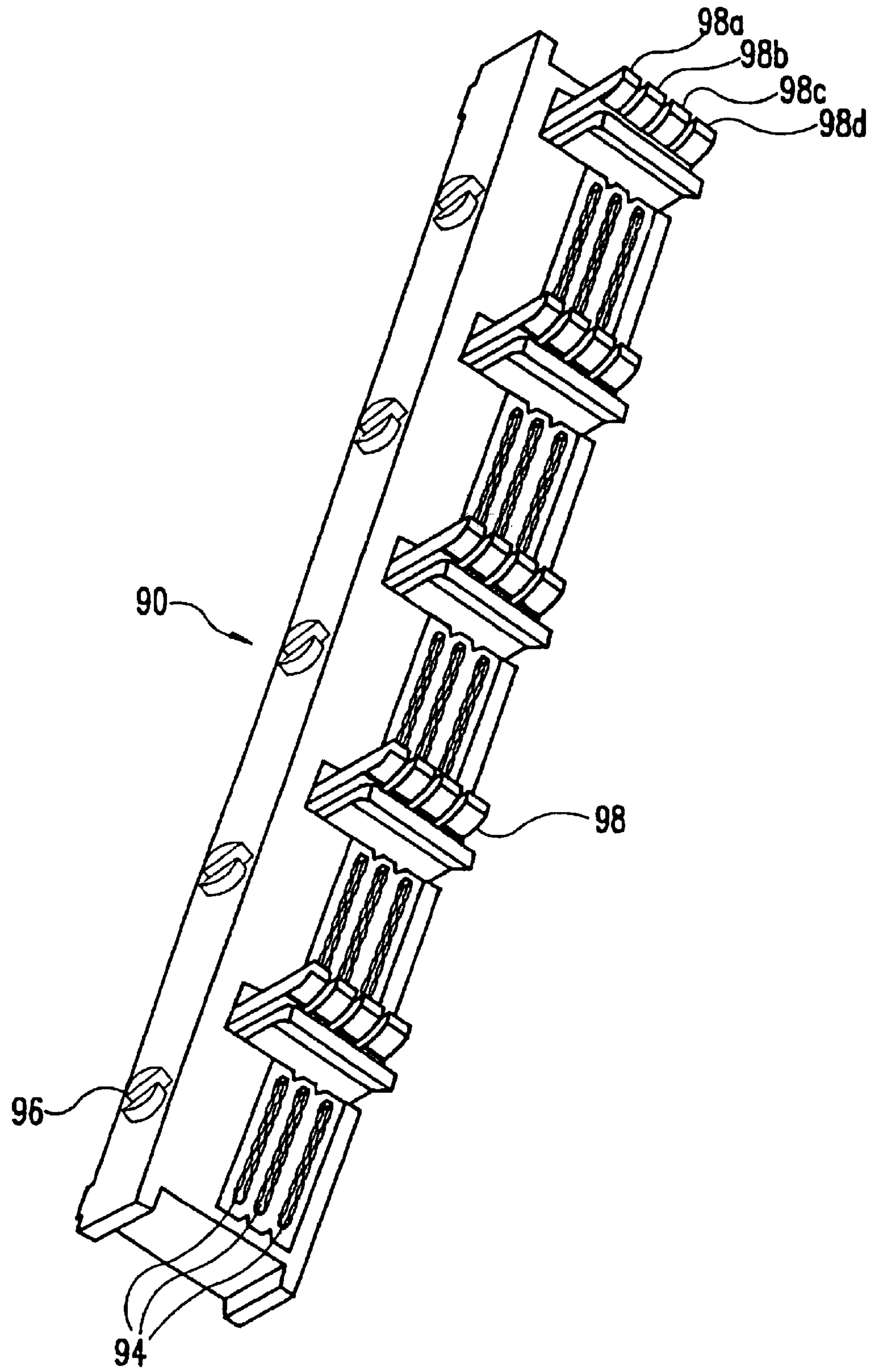
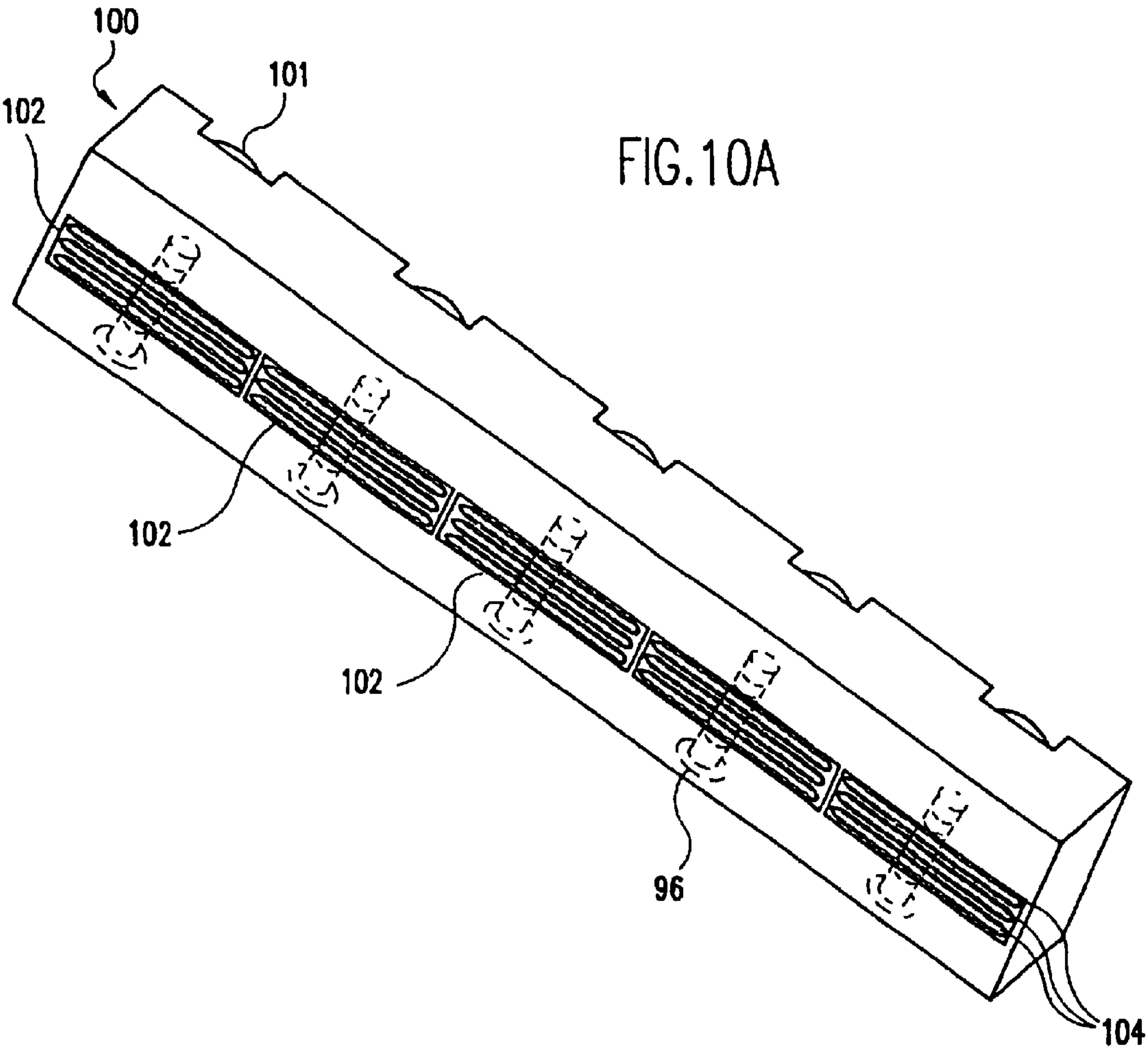
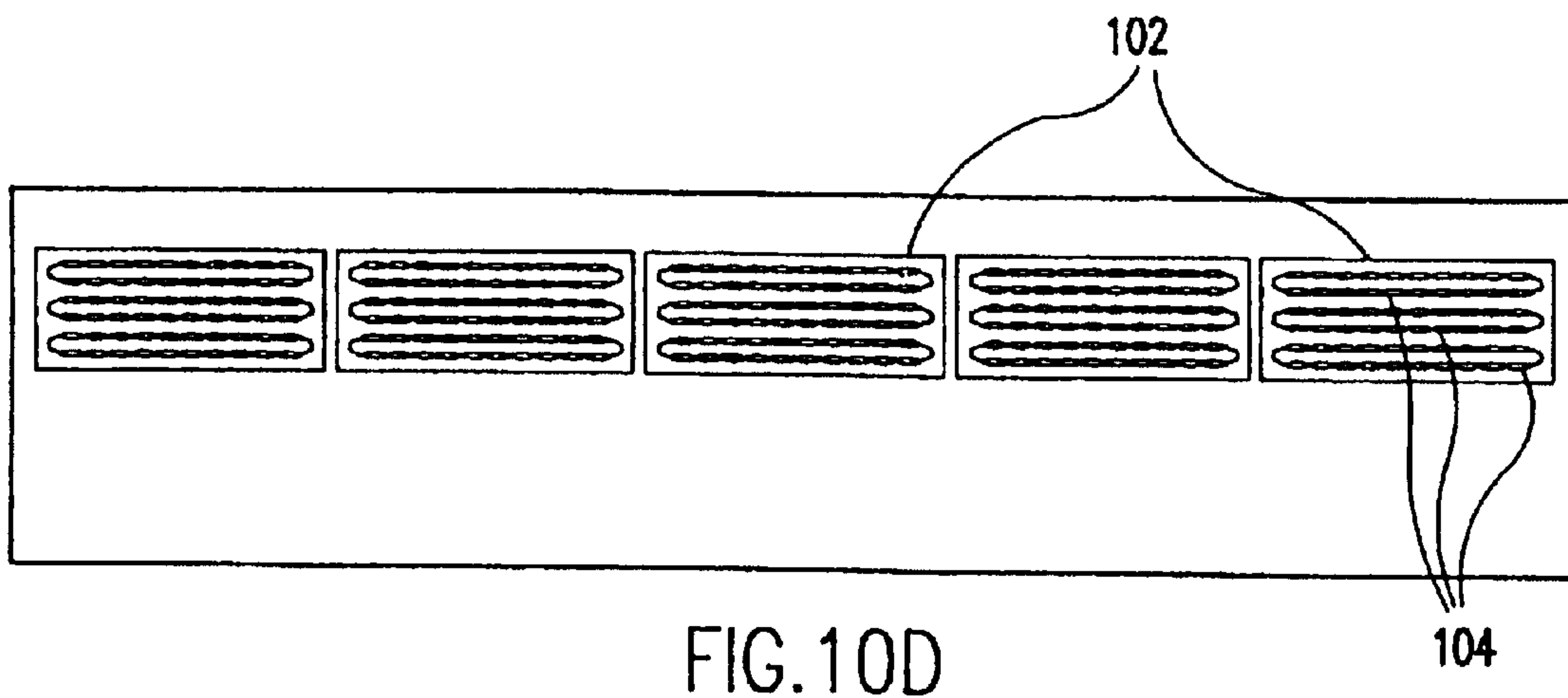
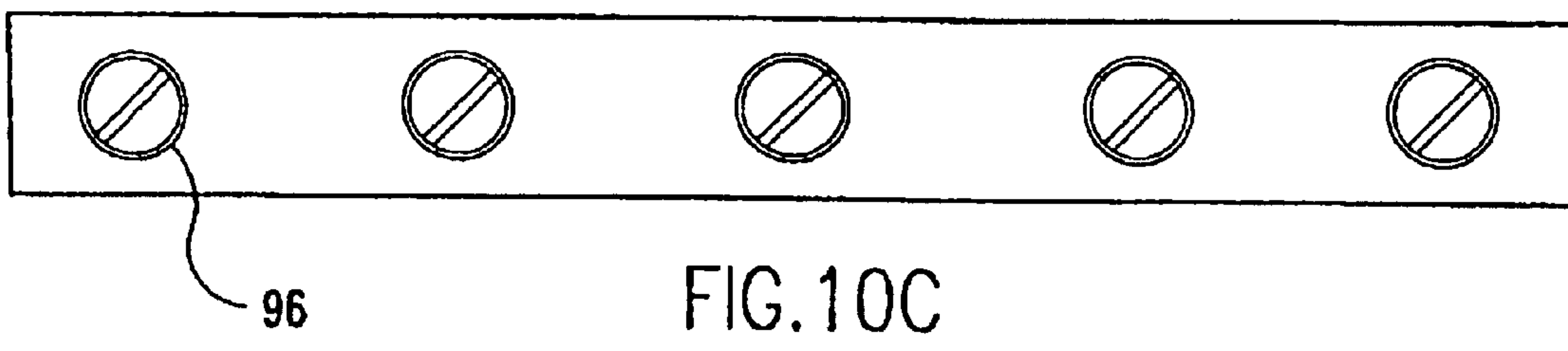
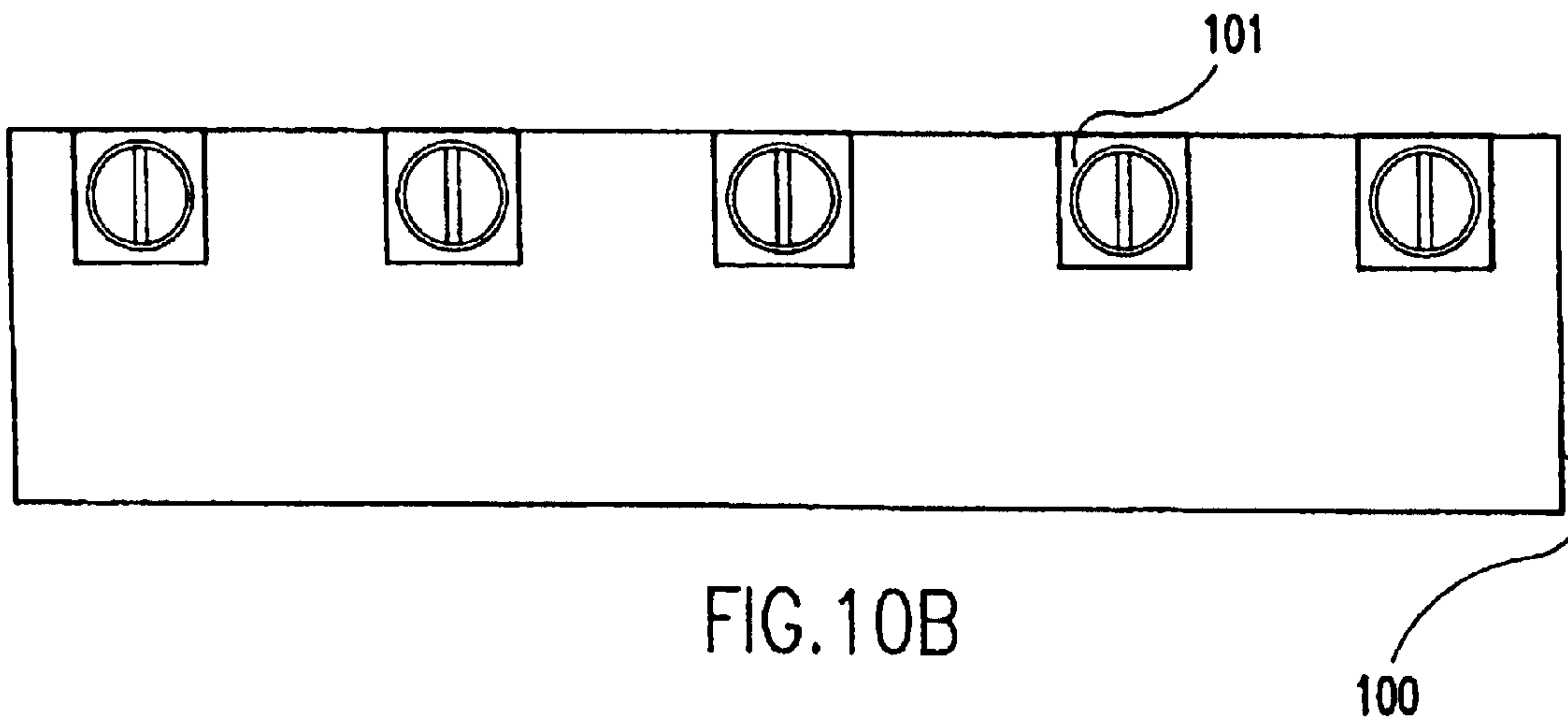

FIG.9E





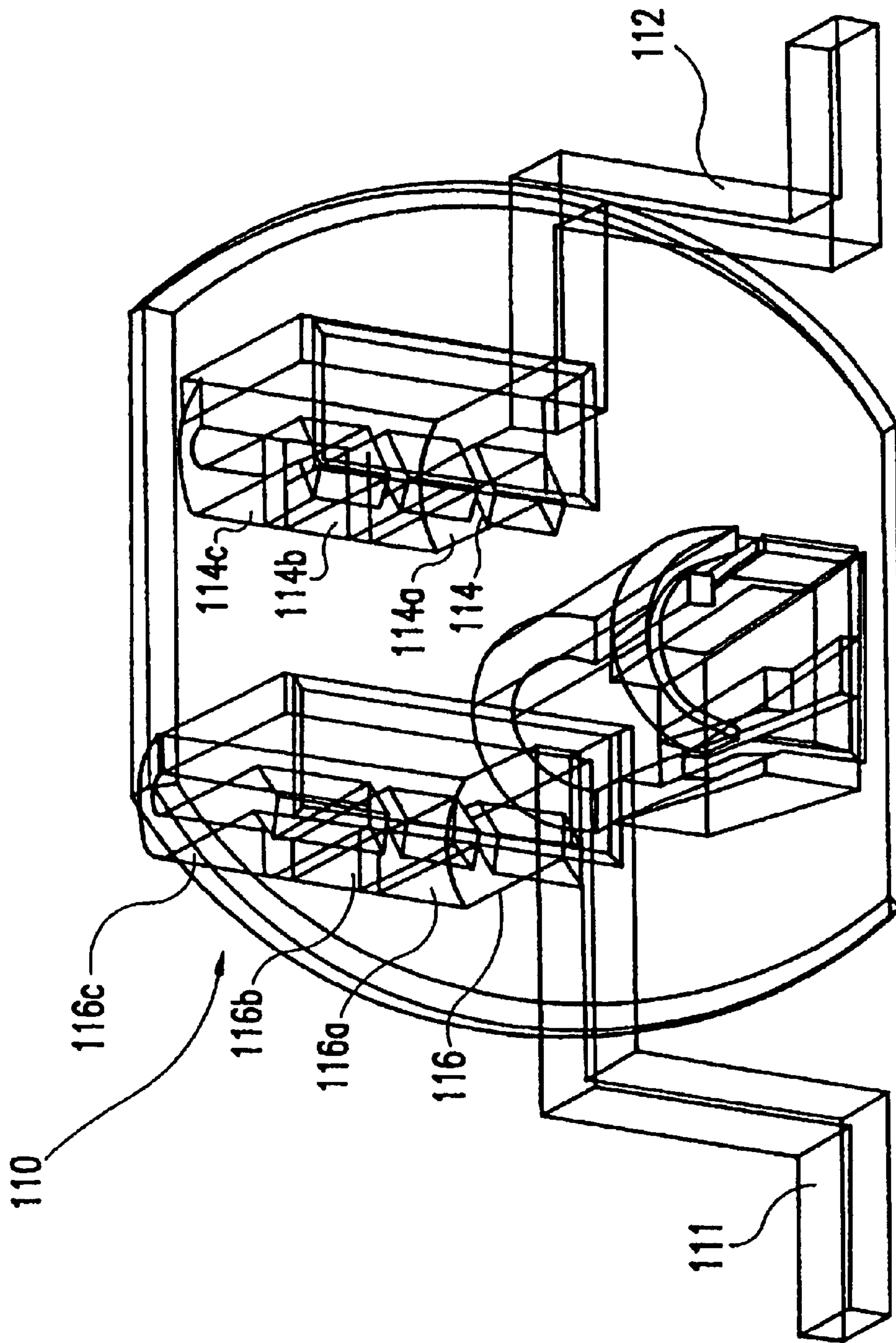

FIG. 111A

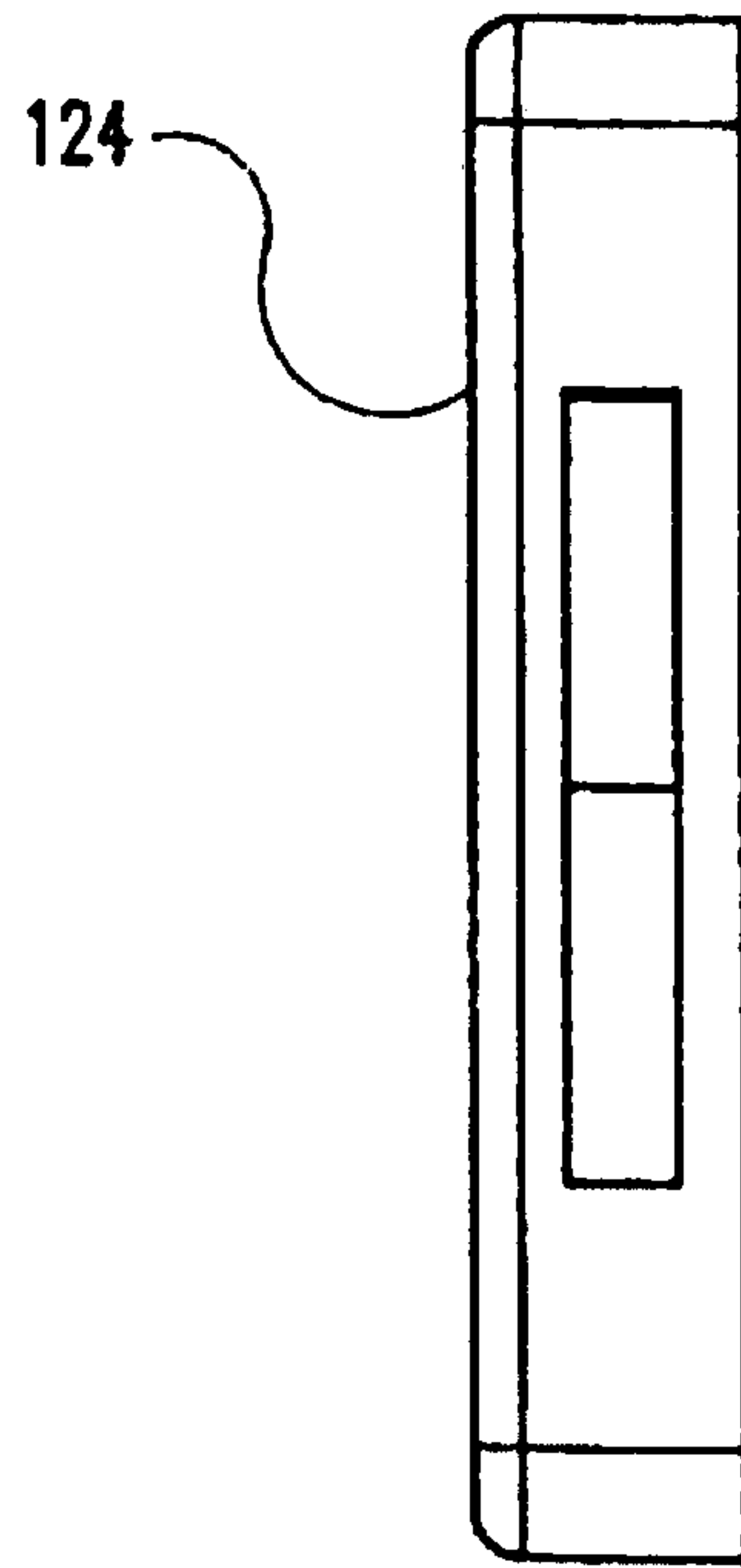

FIG. 11C

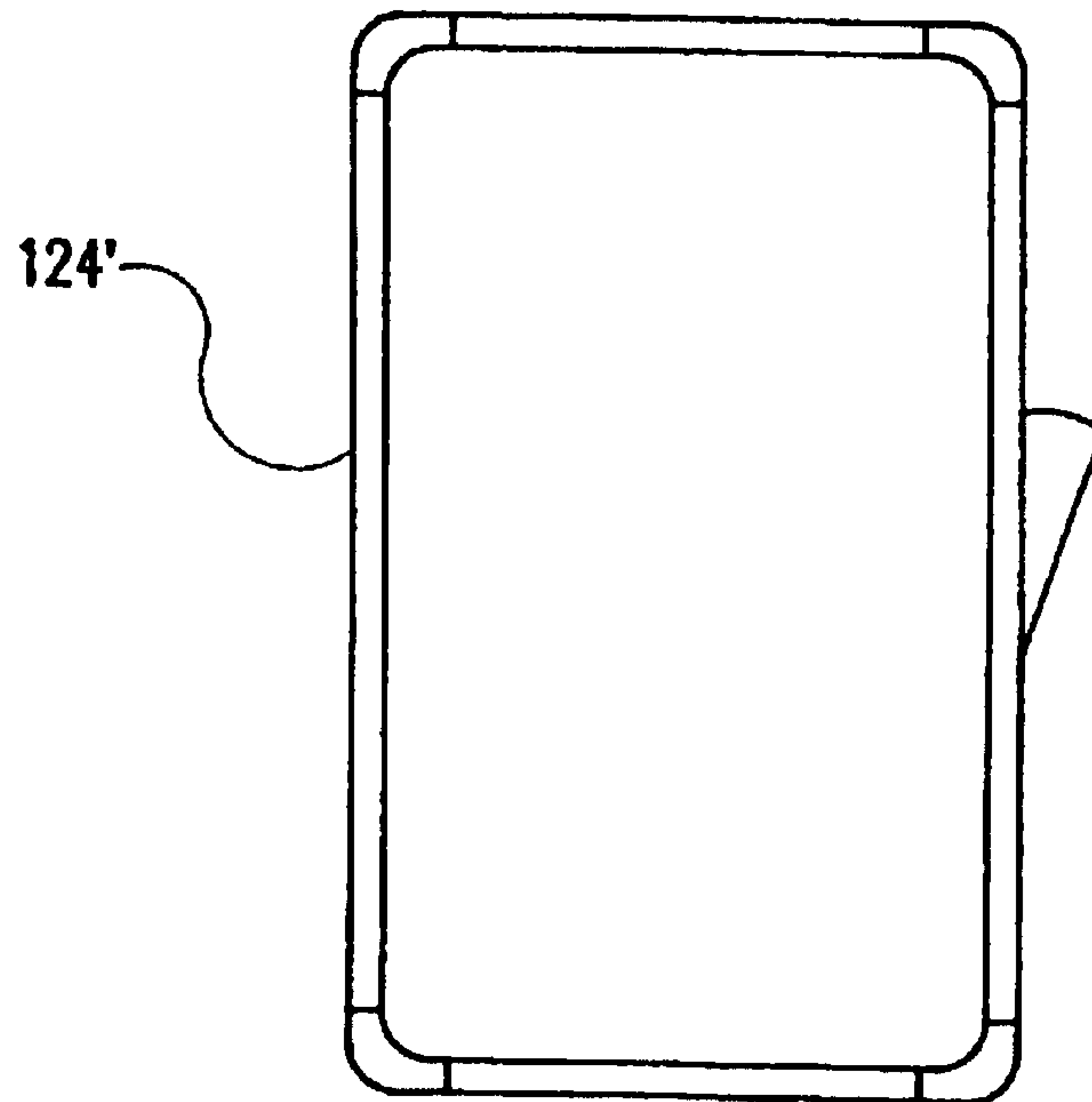

FIG. 11B

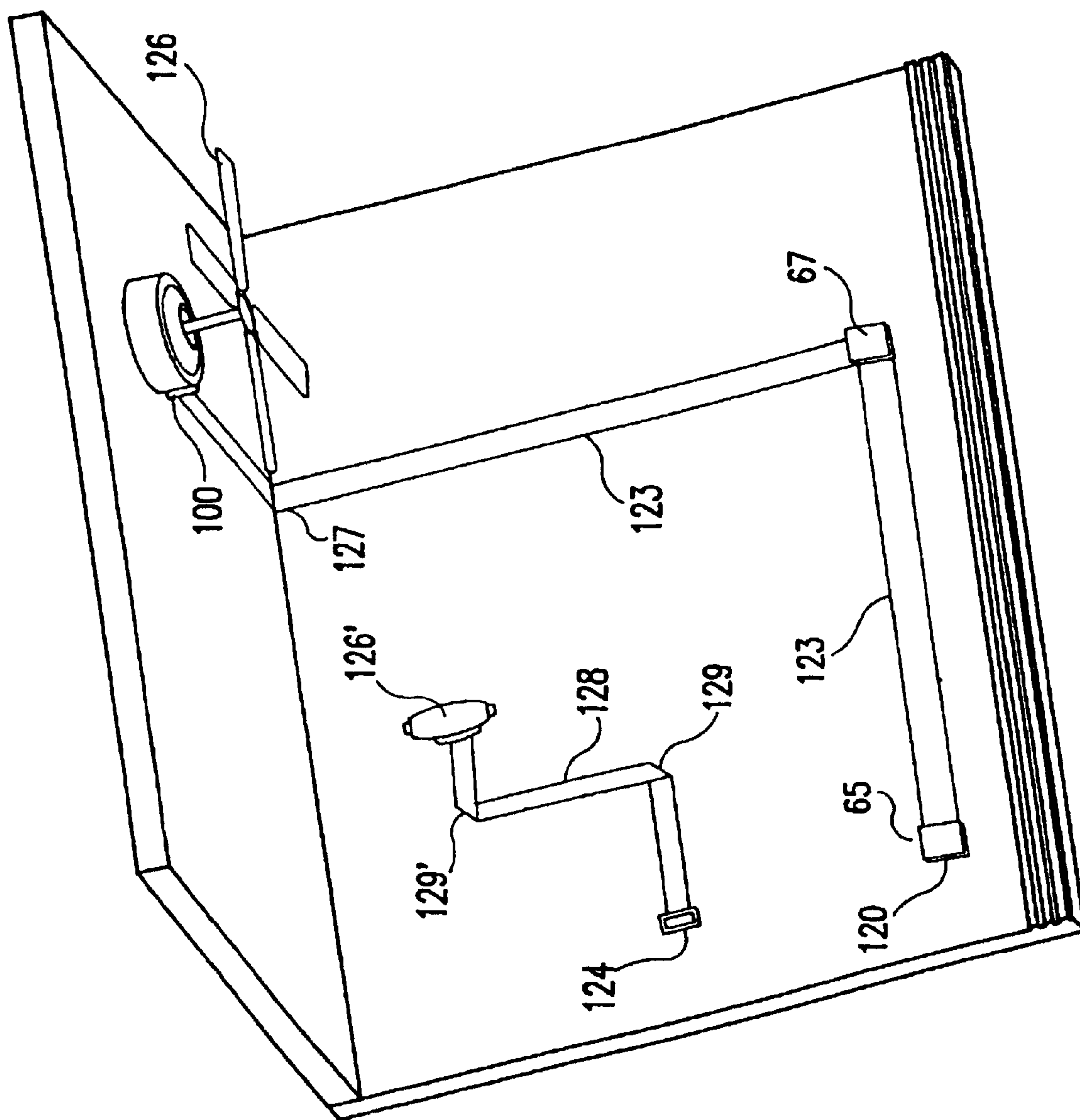
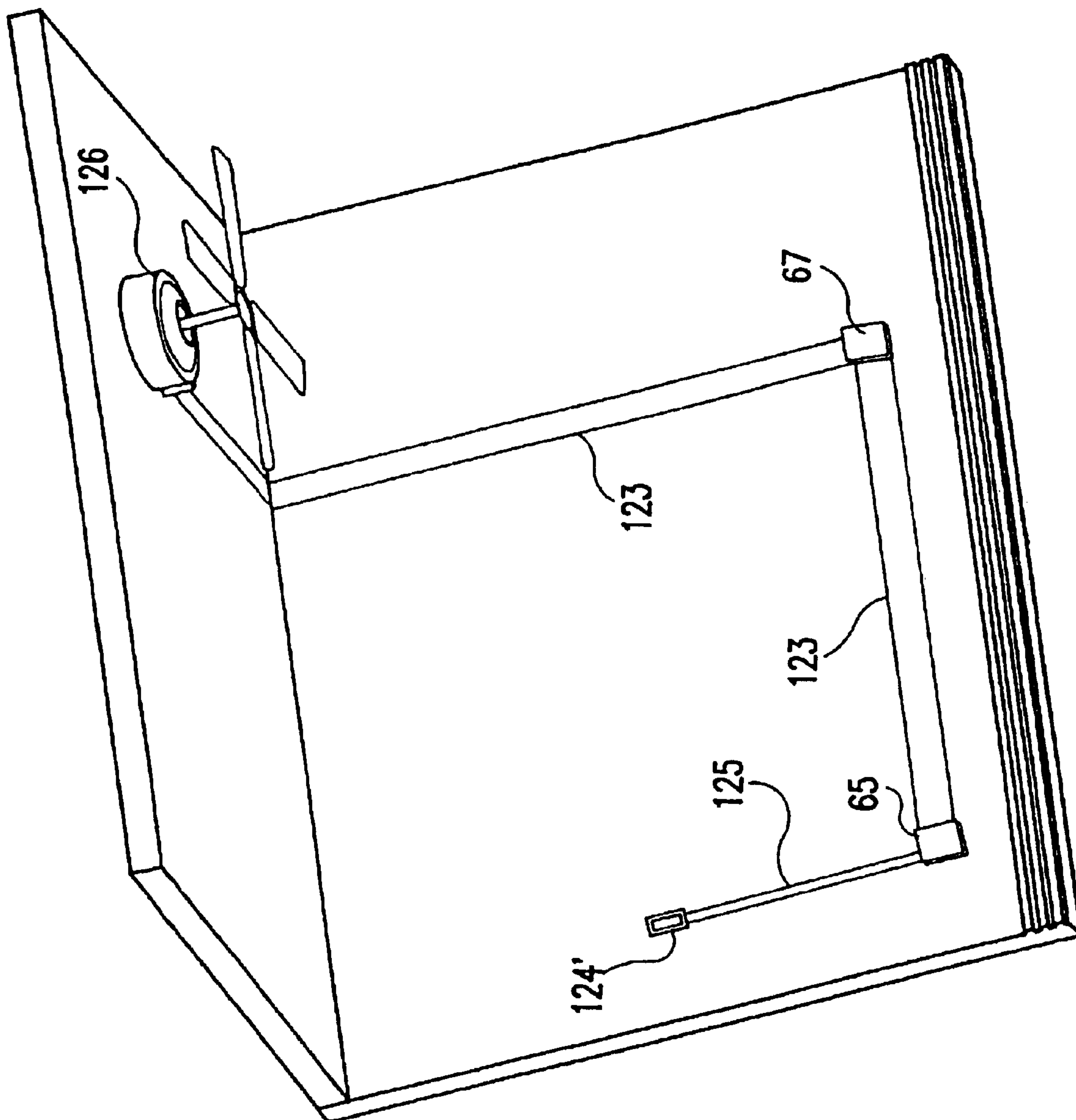

FIG. 12A

FIG. 12B



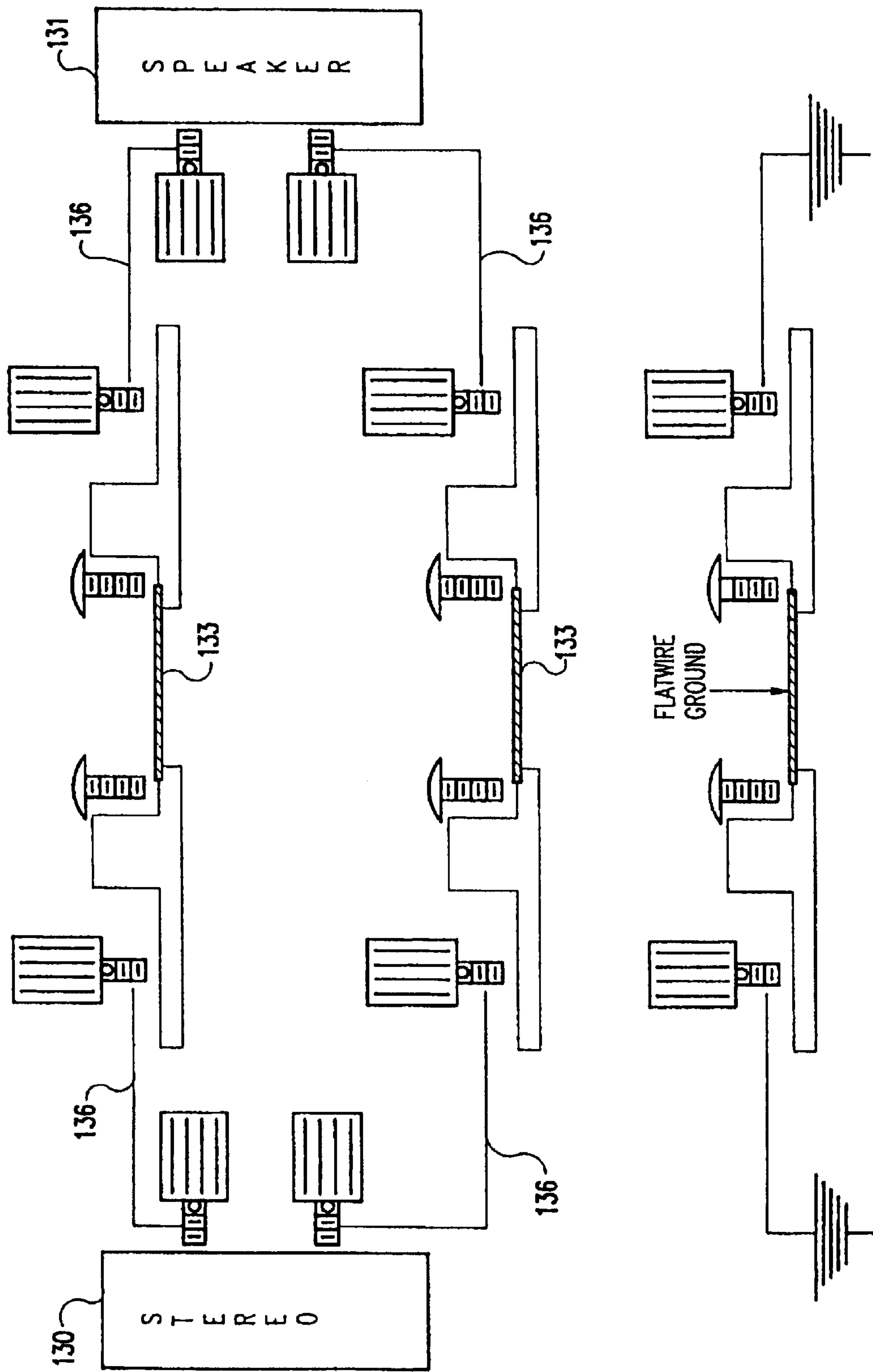

FIG.13

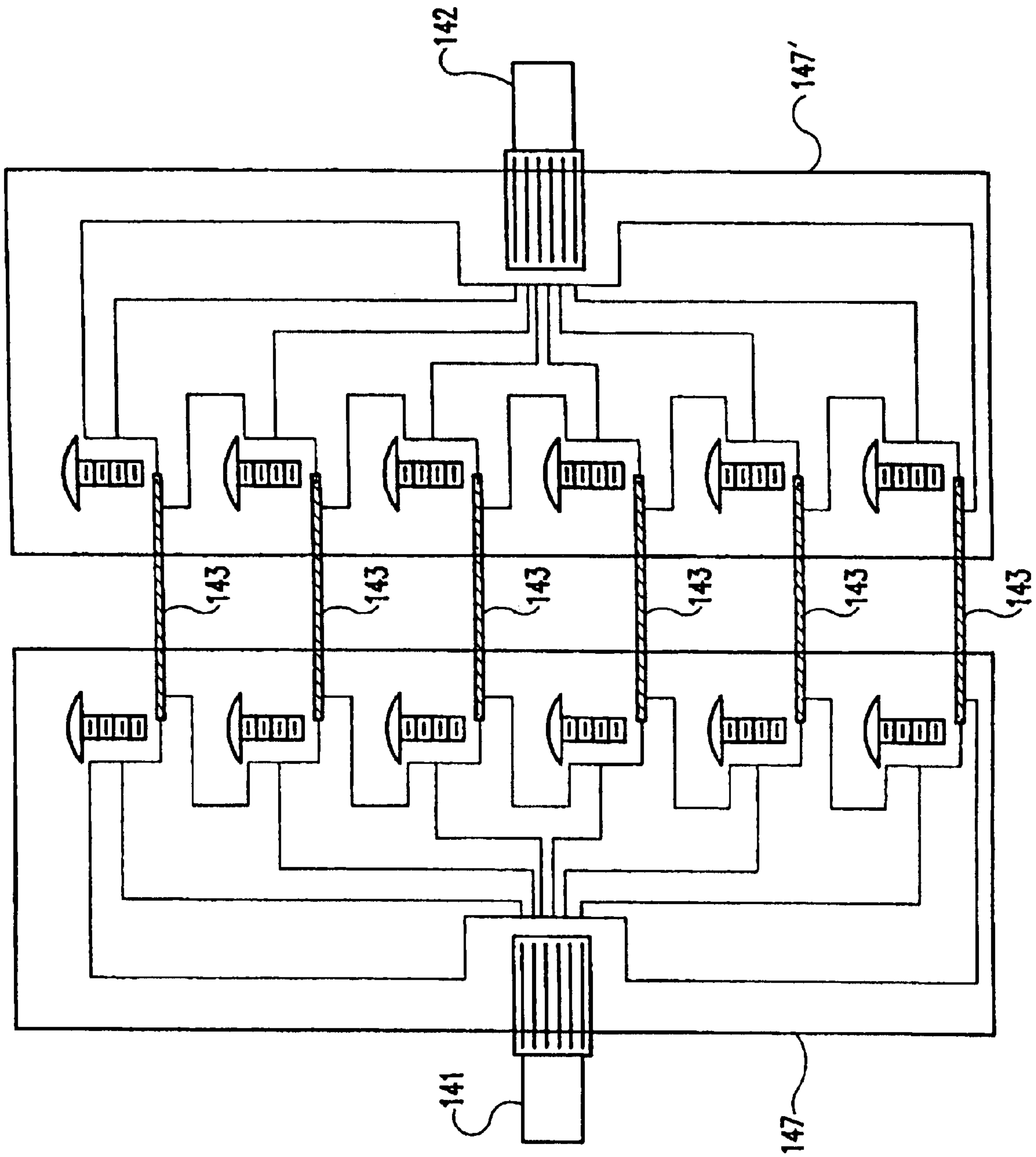

FIG. 14

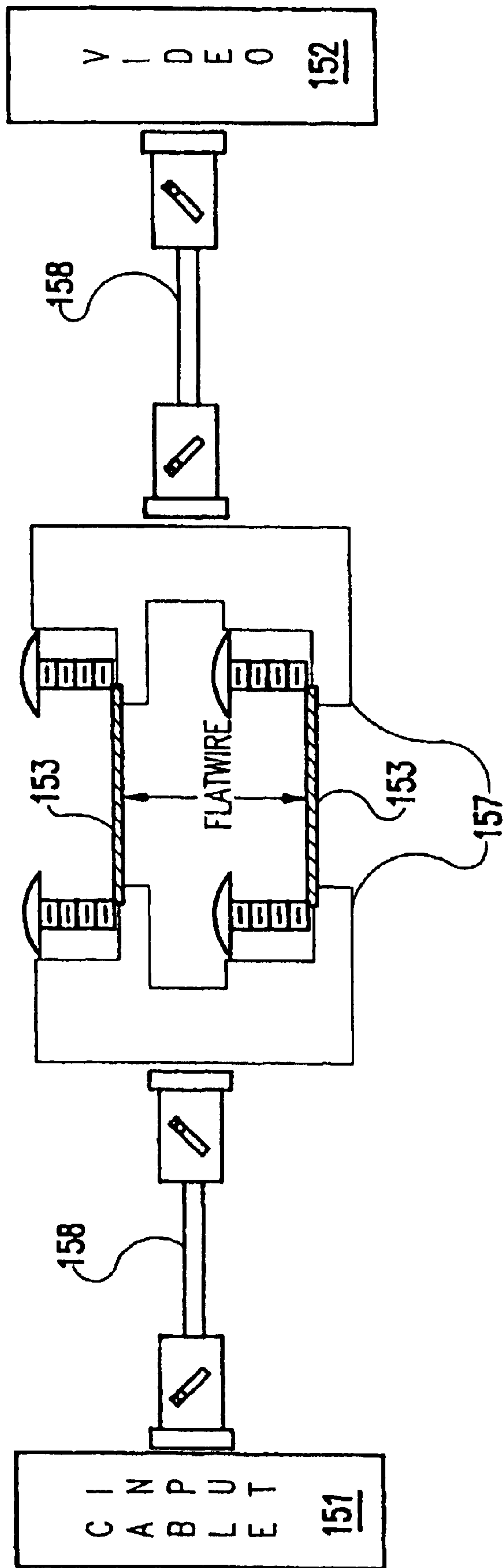

FIG.15

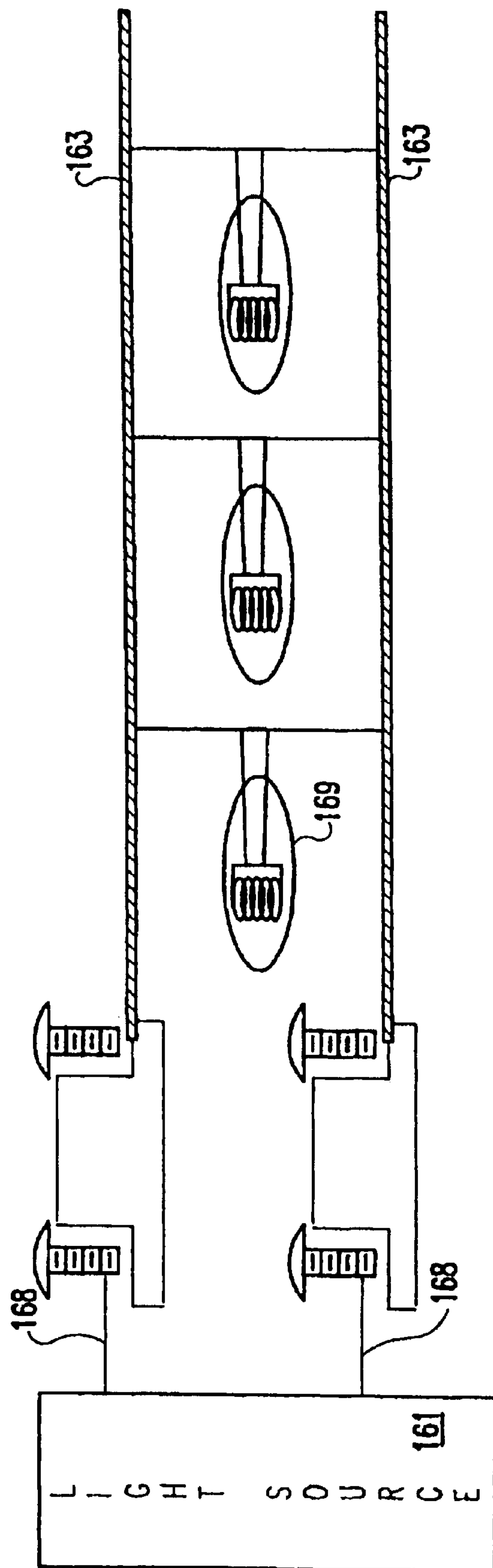

FIG.16

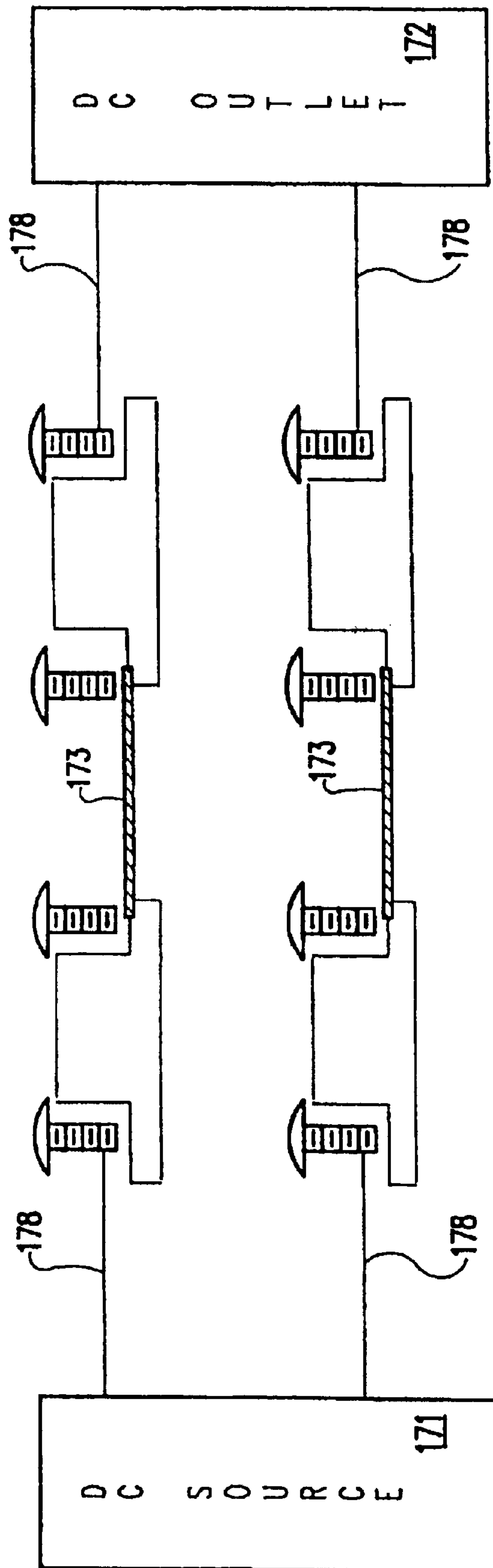

FIG.17

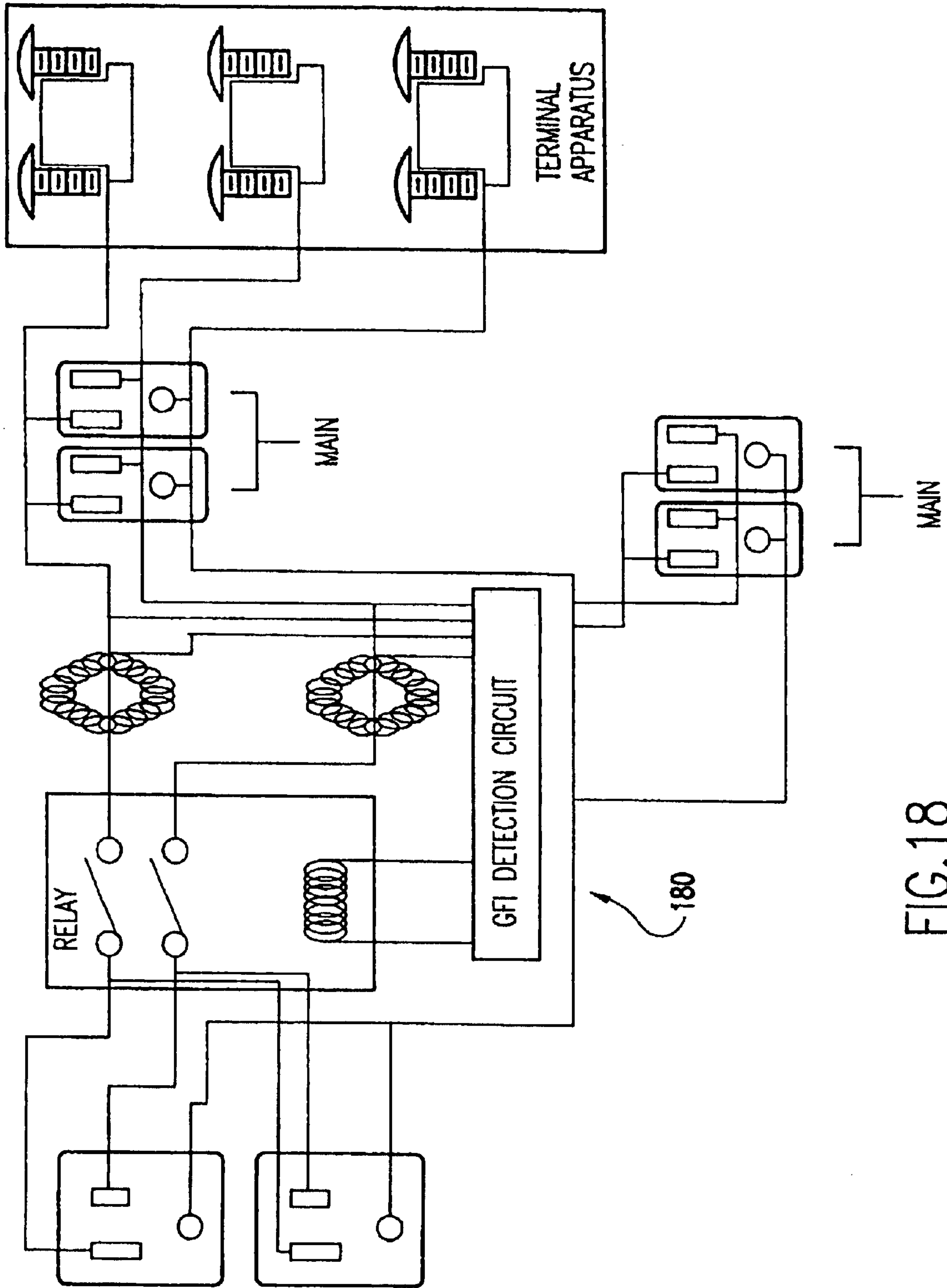

FIG.18

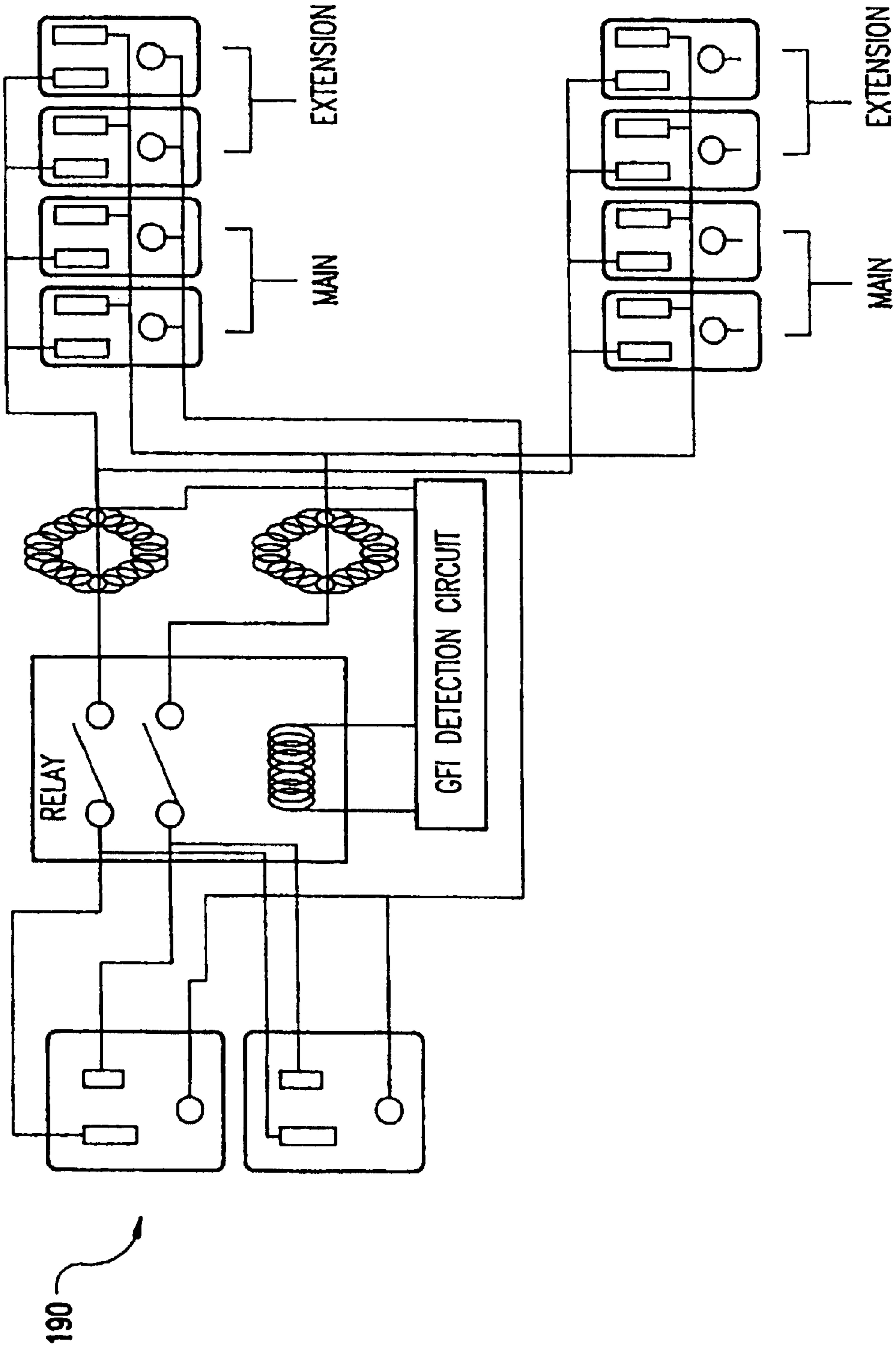

FIG.19

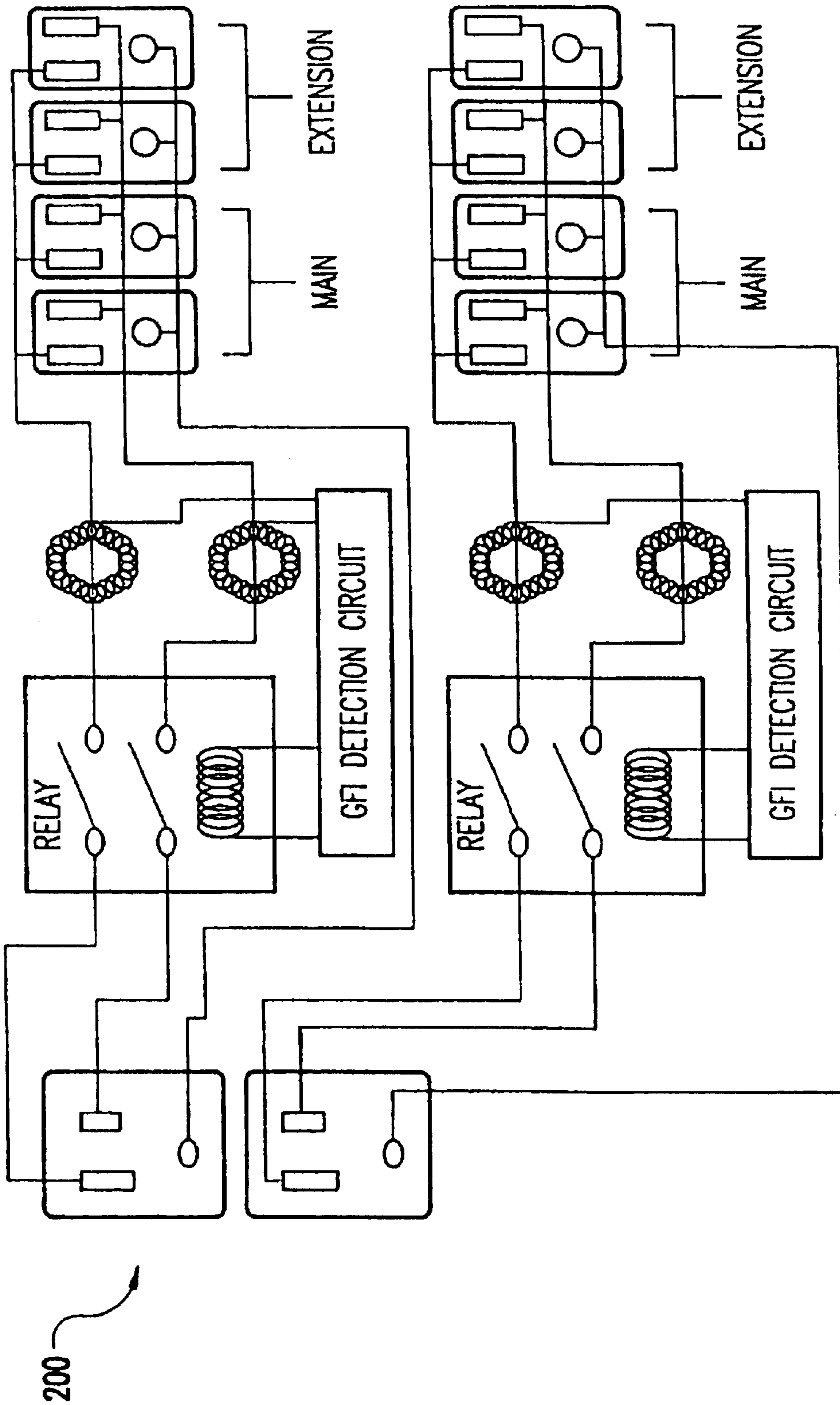

FIG.20

FLAT SURFACE-MOUNTED MULTI-PURPOSE WIRE

Matter enclosed in heavy brackets [] appears in the original patent but forms no part of this reissue specification; matter printed in italics indicates the additions made by reissue.

This application is a continuation of application Ser. No. 08/942,305 filed Oct 1, 1997 now abandoned.

BACKGROUND OF THE INVENTION

1. Field of the Invention

The present invention generally relates to flat wiring, and more particularly, to a thin, bendable, surface-mounted flat wire for use in a variety of wiring applications.

2. Description of the Related Art

Current wiring and re-wiring techniques and procedures present many limitations to the user in existing commercial or residential applications. The choices for adding, changing or moving any of the many wiring applications—electrical, telephone, antenna/CATV, loud speaker, and low voltage wiring, as well as the associated plugs, switches, and connections—is expensive or obtrusive or both.

Temporary or removable methods such as extension cords, long telephone and antenna/CATV cords, external loud speaker wire, and low voltage wire, are cumbersome and hard to hide or blend into a room.

Permanent installations typically require either a professional to install in a wall if the user desires a hidden installation or the use of some type of unattractive and inflexible conduit. Both methods tend to be expensive.

In light of the foregoing, there exists a need for a permanent, non-obtrusive, low-cost, easy to self-install, location specific, hidden system for wiring and re-wiring applications on walls and ceilings. There also exists a need for associated plugs, switches, and connections that could provide an interface between such a new wiring system and conventional wiring.

SUMMARY OF THE INVENTION

The present invention is directed to flat, thin, flexible, multi-layered wires, which substantially obviate one or more of the problems due to the limitations and disadvantages of the related art.

By way of example and not by limitation, the present invention can be utilized in a wide variety of applications, including: standard electrical wiring; telephone wiring; loud speaker wiring; low voltage wiring such as security systems; under surface lighting; and cable TV wiring.

In addition, the present invention includes several unique outlets, switches, and connectors that provide the interface between existing conventional round wiring and the flat wires of the present invention.

To achieve these and other advantages and in accordance with the purpose of the invention, as embodied and broadly described, the invention provides for a surface mounted, flexible, multi-purpose wire, comprising, a plurality of flat elongated conductors spaced apart in a generally parallel relationship, wherein each of the plurality of flat conductors comprises a plurality of copper layers; an adhesive material separating the plurality of flat conductors; and an insulation layer surrounding the flat conductors and the adhesive material, wherein the adhesive material bonds to the insulation layer; and wherein a cross-sectional height of the flat conductors and insulation layer is such that the multi-

purpose wire will blend in with the surface when painted or after wallpaper is applied.

The copper layers are generally on the order of about 0.002 inches thick, but may range from about 0.0004 to 0.020 inches. The number and thickness of the copper layers may be adjusted to suit the desired application. It is understood that the various dimensions described herein may vary considerably within the practice of this invention.

The insulation layer can be composed of materials selected from the group consisting of polyester films (e.g., Dupont Mylar), urethane films, or teflon films. The adhesive material can be selected from the group consisting of adhesive tape (e.g., 3M 9500PC), liquid adhesive, or a combination of the two.

In another aspect, the invention provides for a surface mounted, flexible, multi-purpose wire, comprising a single flat conductor together with the adhesive material and insulation layers as described above.

It is to be understood that both the foregoing general description and the following detailed description are exemplary and explanatory and are intended to provide further explanation of the invention as claimed.

BRIEF DESCRIPTION OF THE DRAWINGS

The foregoing and other objects, aspects and advantages will be better understood from the following detailed description of a preferred embodiment of the invention with reference to the drawings, in which:

FIG. 1 is an exploded side cross-sectional view of a 3-wire flat conductor for use in standard electrical wiring applications;

FIG. 2 is an exploded side cross-sectional view of a 5-wire flat conductor for use in applications requiring two circuits;

FIG. 3 is an exploded side cross-sectional view of a 2-wire flat conductor for use in loud speaker systems;

FIG. 4 is an exploded side cross-sectional view of a 6-wire flat conductor for use in telephone applications;

FIG. 5 is an exploded side cross-sectional view of a 2-wire flat conductor for CATV applications;

FIG. 6 is an exploded side cross-sectional view of a 2-wire flat conductor for use in low voltage applications;

FIG. 7 is a perspective configuration view of the pluggable and stand-alone outlets connected via a flat wire;

FIG. 8A is an exploded perspective view of the components of the outlet assembly of the present invention;

FIG. 8B is an alternate exploded perspective view of the components of the outlet assembly of the present invention;

FIG. 8C is a perspective view of the underside of a fully configured outlet assembly of the present invention;

FIG. 9A is a perspective view of the flat-wire to outlet frame connector interface in accordance with the present invention;

FIGS. 9B, 9C, and 9D provide top, side, and bottom views, respectively, of the flat-wire to outlet frame connector interface in FIG. 9A;

FIG. 9E is a perspective view of the underside of the flat-wire to outlet frame connector of FIG. 9A showing the elongated slots and wipers;

FIG. 10A is perspective view of the flat-wire to conventional-wire connector in accordance with the present invention;

FIGS. 10B, 10C, and 10D provide top, side, and bottom views, respectively, of the flat-wire to conventional-wire connector in FIG. 10A;

FIG. 11A is a three dimensional perspective view of a three wiper female plug receptacle system according to the present invention;

FIGS. 11B and 11C are front and side perspective views, respectively, of a side mounted switch;

FIG. 12A is a perspective view of the surfaced mounted flat wire connected to a ceiling fan;

FIG. 12B is a perspective view of the discrete wired switch embodiment in accordance with the present invention;

FIG. 13 is a diagrammatical representation of a flat wire/loud speaker system configuration;

FIG. 14 is a diagrammatical representation of a flat wire/phone jack system configuration;

FIG. 15 is a diagrammatical representation of a flat wire/CATV system configuration;

FIG. 16 is a diagrammatical representation of a flat wire/embedded light system configuration;

FIG. 17 is a diagrammatical representation of a flat wire/DC power system configuration;

FIG. 18 is a diagrammatical representation of a GFI detection circuit for 4 outlets and 3 terminals without a switchable input plug;

FIG. 19 is a diagrammatical representation of a GFI detection circuit for 8 outlets without a switchable input plug; and

FIG. 20 is a diagrammatical representation of a GFI detection circuit for 8 outlets with a switchable input plug.

DETAILED DESCRIPTION OF EMBODIMENTS OF THE INVENTION

In general, as stated above, the present invention can be used or be adapted to perform in a wide variety of applications including: standard electrical wiring; telephone wiring; loud speaker wiring; low voltage wiring applications such as intercoms and security systems; under surface lighting; and cable TV wiring. In addition, the present invention includes several unique outlets and switches that interface with existing conventional round wiring. Moreover, the present invention also utilizes tape, stripping tools, and unique connectors to implement a particular system embodiment. Each of the individual components will be discussed in greater detail, followed by a description of the applications to which the present disclosure is directed.

Each of the individual wire embodiments share a basic common structure. However, depending on the particular application, various modifications can be made to the basic structure and the dimensions of the structural components to achieve the desired purpose.

For ease of reference, the basic structure will be discussed in detail with reference to the first wire embodiment. It is understood that this basic structural concept applies to all the wire embodiments. Modifications to the basic structure will be discussed where appropriate. Like reference numbers will be used where possible to refer to similar parts throughout the drawings.

Wire Embodiments

Alternating Current (AC) Electrical Wire

Referring now to the drawings, and more particularly to FIG. 1, there is shown an exploded side cross-sectional view of a standard 110 VAC 3-conductor wire embodiment in accordance with the present invention. The exploded cross-sectional view is for illustrative and discussion purposes

only. In the actual 3-conductor embodiment, there would be no visible spacings (i.e., the white areas in FIG. 1) between the conductors, insulation, and adhesives components, each of which is described further below.

Generally, the electrical wire 10 is a flat, flexible, wire that allows the user to bring electricity to any area of a wall or ceiling in a room. The electrical wire 10 is mounted to the surface of the wall or ceiling, thereby eliminating the need for costly inner wall or ceiling rewiring. The wire may be painted or papered over to match the rest of the surface.

The electrical wire 10 comprises a plurality of elongated and parallel spaced multi-layer conductors 11. As shown in FIG. 1, a typical 110 VAC 3-wire embodiment would include an AC ground conductor, an AC neutral conductor, and an AC power conductor.

An internal adhesive material 13 separates the flat conductors 11 as well as providing edge sealing of the outer flat conductors as shown in FIG. 1. The adhesive material 13 and conductors 11 are surrounded by a thin layer of insulation material 15. In addition, an external adhesive layer 17 is applied to the back of the flat wire to attach the electrical wiring to the desired surface.

Each of the conductors 11 are comprised of one or a plurality of layers made with a copper material that is about 0.0004 to about 0.020 inches thick, and preferably on the order of about 0.002 inches thick. Three copper layers 11a, 11b, and 11c, are shown in FIG. 1 for example. The conductor layer thickness should be consistent across its length and width, thereby eliminating any resistance "hot spots".

The current and or signal carrying specifications of a particular application may be accomplished in any of three ways, either individually or in combination. First, the width 'w_c' of the conductors 11 may be varied. Second, additional thin copper layers may be stacked for each conductor 11. Third, the thickness 't' of the conductor 11 may be increased.

For most load and current applications, each conductor will generally be composed of about 2-5 layers of copper. It is understood, however, that utilizing more or less layers, for each of the below disclosed embodiments, is within the scope of this invention.

For example, a five copper layer conductor, where each copper layer is about 0.002 inches thick, will be on the order of 0.012 inches thick including insulation. Even at that thickness, however, the flat wire presents an extremely thin cross-section that is virtually undetectable on a surface once painted or papered over.

The insulation layer 15 will now be described in greater detail. Insulation is achieved with minimum thickness to prevent conduction under ideal conditions only. The primary purpose of the insulation layer 15 is to assist in the optical occlusion of the presence of the wire as applied to a surface so that a pleasing appearance can be achieved upon installation.

The insulation layer 15 also orients the copper conductive layers. In addition, the insulation material may be used alone, or in combination with the internal adhesive 13, to separate the conductive layer groups and maintain a safe dielectric distance between conductors of different purposes (e.g., AC ground vs AC neutral or AC power conductors).

As shown in FIG. 1, the insulation layer 15 at the edges of the multi-layered flat wire 10 may be, but need not be, tapered to facilitate the optical occlusion. The insulative material may be selected from the group consisting of, for example, polyester films (e.g., Dupont Mylar), urethane films, or teflon films.

5

It is understood that additional insulative materials are considered to be within the scope of this invention and may be used so long as the insulation is compliant, paintable, and bondable to surfaces. The insulation should also be compatible with joint compounds, be UV tolerant, and have similar thermal expansion and contraction characteristics as that of the conductors and the surface to which it is adhered.

Other desirable properties are that the insulation should withstand tensile forces applied in the fabrication process, not retract or relax under storage conditions, and be removable when its use is completed.

Any abrasion, cracking, cutting, piercing, or any other insulation damage—that would render an unsafe exposure to electrical harm—will be made safe using electronic means of failure detection that will disconnect harmful currents from the user in a time frame that will prevent permanent harm. This electronic failure detection means, or Ground Fault Interrupter (GFI) circuit, is discussed in greater detail later in the specification.

Returning to FIG. 1, the internal adhesive material **13** must be able to bond to the insulation layer **15**. For example, adhesive tape (e.g., 3M 9500PC), liquid adhesive, or a combination of the two, may be used as an internal adhesive. The internal adhesive material **13** will also function to separate the conductive layer groups and maintain a safe dielectric distance between conductors of different purposes. In addition, the adhesive **13** can even out gaps in the various components within the wire to aid in its ability to visually disappear on a surface.

The thickness of the internal adhesive material **13** closely approximates the cross-sectional height 't' of the conductors **11**, especially where the internal adhesive separates the conductors **11**. As shown in FIG. 1, the internal adhesive **13** may be tapered at the edges of the flat wire **10** to facilitate the optical occlusion.

An external adhesive layer **17** is provided for attaching the wire to the desired surface. The external adhesive layer **17** could be, for example, two-sided tape, with one side being fixed to the back of the flat wire **10** and the other to the wall or surface. Alternatively, a chemical adhesive may be applied separately, and may consist of any of the adhesives with good bonding qualities to both the insulation layer **15** and the desired surface to which the flat wire **10** is adhered.

A finished flat 3-conductor wire **10**, having, for example, three copper layers of 0.002 inch thickness, would be approximately 0.007 to 0.010 inches in cross-sectional height 't'. For a 15 amp rated wire, the entire width 'W' of the 3-conductor flat wire **10** is on the order of about 2.0–2.5 inches. The width 'w_c' of each conductor is about 0.4–0.6 inches, and the spacing between conductors 'w_s' is about 0.2–0.3 inches.

To ensure readily identifiable, proper and safe connections, the width 'w_c' of the AC ground conductor could be increase slightly as compared to the AC neutral and AC power conductors. The width of the AC ground conductor would therefore be closer to 0.6 inches, while the widths of the other two conductors would be closer to 0.4 inches. Alternatively, the width of the AC ground conductor could be reduced as compared to the other conductors.

Similar dimensions would be useful for other applications, however, it is understood that the various dimensions can vary considerably within the practice of this invention.

The flat wire **10** provides a simple, low cost alternative to expensive rewiring jobs for supplying electricity to specific locations of walls and ceilings for use in fans, ceiling lighting, or wall or art lighting.

6

In FIG. 2, there is shown an exploded side cross-sectional view of a 110 VAC 5-conductor wire **20** of the present invention, having 5 parallel spaced multi-layered copper conductors **11**. This 5-conductor wire embodiment includes all of the features of the 3-conductor wire embodiment disclosed above, with the addition of two conductors **11** to accommodate a second circuit. Like or similar parts are identified by the same reference numerals.

The 110 VAC 5-conductor wire is used where two circuits on one flat wire are desirable, such as a wire leading to a light and a fan, or where a switched plug is used. In this embodiment the five conductors consist of two AC neutral conductors, two AC power conductors, and a single AC ground conductor.

The number and thickness of the copper layers, the width 'w_c' and thickness 't' of the conductors **11**, and the spacing between the conductors 'w_s' are generally of the same dimensions as that of the 110 VAC 3-conductor wire. The overall width 'W' of the finished flat wire **20** is on the order of about 3.5–4.25 inches.

The flat wire conductors of the present invention may also be utilized to construct a 220 VAC wire embodiment, generally as shown with reference to FIG. 1. A finished flat 3-conductor 220 VAC wire, having, for example, four copper layers of about 0.002 inch thickness, would be approximately 0.012 inches in cross-sectional height 't'. The entire width 'W' would be on the order of about 3.0–3.5 inches. The width 'w_c' of the neutral and power conductors is about 0.4–0.6 inches, while the width 'w_c' of the ground conductors is about 0.2–0.4 inches. The spacing between conductors 'w_s' is about 0.4–0.6 inches.

As in the 3-conductor 110 VAC electrical wire, the difference in ground conductor width in the 3-conductor 220 VAC electrical wire is to facilitate proper connection of the wires to the connectors.

Loud Speaker Wire

As with the previous embodiments, the loud speaker wire **30** of the present invention, illustrated in FIG. 3, is a flat, thin, flexible, wire that allows the user to position loud speakers at any area of a wall or ceiling in a room. The loud speaker wire **30** may be used, for example, with stereo or mono audio components, or for wiring external speakers for enhanced television or sound systems such as "surround sound".

The loud speaker wire **30** can be mounted to the surface of a wall or ceiling, thereby eliminating the need for costly inner wall or ceiling rewiring. The wire may also be painted or papered over to match the rest of the surface.

Referring to FIG. 3, the thin loud speaker wire **30** is comprised of a pair of multi-layered copper conductors **11**. The conductive capacity of the loud speaker wire **30** is preferably equivalent to 10 gauge stranded wire. Each of the conductors **11** would generally have two or three copper layers, the former being shown by copper layers **11a** and **11b** in FIG. 3. The copper layers are about 0.0004 to about 0.020 inches thick, and preferably on the order of about 0.002 inches thick. It is understood that depending on the particular application, more or less copper layers may be utilized.

The pair of conductors **11** are separated by an appropriate adhesive material **13** and both are surrounded by an insulation layer **15** as discussed above. Similar insulation and adhesives may be used as previously described above.

Because of its application, the loud speaker wire **30** may also include a shielding material **18** surrounding the conduc-

tors **11** to reduce outside signal and cross-over interference. The shielding material **18** may be one or a plurality of layers of any suitable metallic or semi-metallic shielding materials, for example, aluminum or metalized polyester films.

The finished loud speaker wire **30** is approximately 0.008 inches in cross-sectional height 't' with three copper layers, with an overall width 'W' of about 2.5–3.0 inches. The width 'w_c' of each conductor is about 0.6–0.8 inches, and the spacing between the conductors 'w_s' is about 0.2–0.3 inches.

As shown in FIG. 3, the edges of the wire **30** may be tapered to facilitate the optical occlusion. A similar external adhesive layer **17** as that previously described is also provided to attach the loud speaker wire **30** to the appropriate surface.

Telephone Wire

An illustrative example of a telephone wire embodiment **40** according to the present invention is shown in FIG. 4. In this embodiment, six multi-layered copper conductors **11** are provided, separated by adhesive material **13**, and surrounded by insulation layer **15**. A six conductor wire facilitates the use of Private Branch Exchange (PBX) switching, thereby providing a private telecommunications exchange that includes access to a public telecommunications exchange. The conductors **11** are functionally equivalent to standard 22 gauge telephone wire.

Two, four, and eight multi-layered copper conductor telephone wires may also be utilized. Moreover, the eight conductor embodiment approximates four twisted pair wires (e.g., unshielded twisted pair (UTP) wire), which may be suitable for carrying data.

Each of the conductors **11** would generally have two or three copper layers, the former being shown by copper layers **11a** and **11b** in FIG. 4. The copper layers are about 0.0004 to about 0.020 inches thick, and preferably on the order of about 0.002 inches thick. It is understood that, depending on the particular application, more or less copper layers may be utilized.

The finished telephone wire **40**, with three copper layers, is approximately 0.008 inches in cross-sectional height 't', with an overall width 'W' of about 1.5–3.5 inches, depending on the number of conductors **11** utilized. The width 'w_c' of each conductor is about 0.2–0.4 inches, and the spacing between the conductors 'w_s' is about 0.125–0.25 inches.

As shown in FIG. 4, the edges of the wire **40** may be tapered to facilitate the optical occlusion. A similar external adhesive layer **17** as that previously described is also provided to attach the telephone wire **40** to the appropriate surface.

Cable Television CATV Wire

An illustrative example of a cable television CATV wire embodiment **50** in accordance with the present invention is shown in FIG. 5. In this embodiment, a pair of conductors **11** are provided, each of which may generally have two or three copper layers, the former being shown by copper layers **11a** and **11b** in FIG. 5. The copper layers are about 0.0004 to about 0.020 inches thick, and preferably on the order of about 0.002 inches thick. It is understood that, depending on the particular application, more or less copper layers may be utilized.

As in the previous embodiments, the conductors **11** are separated by adhesive material **13**, and surrounded by insulation layer **15**. As shown in FIG. 5, the edges of the wire **50** may be tapered to facilitate the optical occlusion. A similar

external adhesive layer **17** as that previously described is also provided to attach the wire **50** to the appropriate surface.

The finished antenna/CATV wire **50**, with three copper layers, is approximately 0.008 inches in cross-sectional height 't', with an overall width 'W' of about 1.8–2.2 inches. The width 'w_c' of each conductor is about 0.4–0.6 inches. As shown in FIG. 5, the spacing between the conductors 'w_s' is about 0.4–0.6 inches, which is somewhat larger than in previous embodiments in order to reduce radio frequency interference and improve transmission quality. The CATV wire is rated at 300 ohms.

Low Voltage Wire Applications

FIG. 6 illustrates a low voltage wire embodiment **60** in accordance with the present invention. Such low voltage (direct current) applications would include intercoms, security systems, and "smart house products". As shown in FIG. 6, two DC power conductors **11** are shown. The structure of the conductors **11** is essentially the same as the multi-layer conductors **11** described earlier. The internal adhesive material **13**, insulation layer **15**, and external adhesive layer **17**, would be the same in this embodiment as those described previously.

Each of the conductors **11** would generally have two or three copper layers, the later being shown by copper layers **11a**, **11b**, and **11c** in FIG. 6. The copper layers are about 0.0004 to about 0.020 inches thick, and preferably on the order of about 0.002 inches thick. It is understood that, depending on the particular application, more or less copper layers may be utilized.

The finished low voltage wire **60**, with three copper layers, is approximately 0.008 inches in cross-sectional height 't', with an overall width 'W' of about 1.2–1.6 inches. The width 'w_c' of each conductor is about 0.3–0.5 inches, and the spacing between the conductors 'w_s' is about 0.2–0.3 inches.

As shown in FIG. 6, the edges of the wire **60** may be tapered to facilitate the optical occlusion. A similar external adhesive layer **17** as that previously described is also provided to attach the telephone wire **60** to the appropriate surface.

Under Surface Lighting Wire

While the thin, flexible wire for under surface lighting is similar in construction to the 110 VAC 3-conductor and 5-conductor wire embodiments described above, it is unique in that the under surface lighting wire incorporates embedded lights **169**. See FIG. 16. This allows the user to install the lighting under a surface of a cabinet, shelf, or other locations where under surface lighting is desired. This embodiment will be described in greater detail in the discussions of the conventional wire-to-flat wire system implementations later in the specification.

Outlets and Connectors

The present invention encompasses a family of outlets that provide connection points between the flat wires of the present invention and conventional existing electrical outlets and conventional round wire systems. These connecting outlets are of two general types, with one being directly "pluggable" into a conventional existing outlets, while the other is a "stand-alone" surface mounted unit.

The pluggable connecting outlets will always provide the compatibility interface between the standard household electric wiring apparatus and the various embodiments of

the flat wires in accordance with the present invention. Accordingly, the pluggable outlet is always at the source of the standard electrical current. The stand-alone unit interfaces with the pluggable unit via the various flat wire embodiments of the present invention.

FIG. 7 illustrates the typical configuration interface between the pluggable and stand-alone units. Assuming that a conventional two-female receptacle outlet, as fed by conventional round wire 69 from behind the wall 66, is located behind outlet 65. Outlet 65 would therefore be of the directly “pluggable” variety. Outlet 67 would thus be a stand-alone outlet that is affixed to the wall without a plug attachment. The stand-alone outlet can therefore be placed anywhere in the room, regardless of the location of the existing outlets.

In the electrical wire embodiments, for example, current from the conventional wire 69 is transferred to the stand-alone outlet 67 via pluggable outlet 65 and the flat 110 VAC wire 68 of the present invention.

FIG. 8A is an exploded perspective view of the pluggable outlet unit 65, depicting the various internal and external components of the outlet. As shown, the outlet 65 contains side mounted female receptacles 72 and 73 housed within an outlet cover 74. Alternatively, the female receptacles 72 and 73 may be mounted in the front as in standard outlet configurations. The side mounted receptacle version has an advantage in that the outlet cover 74 may be painted or papered to blend into the surface. Also, additional female receptacles 72' and 73' may be located on another side of the outlet cover 74 as in FIG. 8B, which shows four female receptacles.

The outlet base 75 for the pluggable outlet 65 contains openings 75a and 75b that would be positioned over the female receptacles of the conventional existing outlet, and affixed to the surface with screws or other equivalent attachment devices. The outlet cover 74 would then be placed over the base 75.

The pluggable outlet 65 also contains a flat wire connector 76 and a Ground Fault Interrupter (GFI) module 77 with its associated GFI reset button 78. The GFI module 77 (the operation of which is discussed later in the specification) contains two sets of male contacts 79 and 79' that pass through the openings 75a and 75b to plug into the respective female receptacles associated with conventional wiring systems. The GFI module 77 functions to interrupt the electric current to the load in the event the flat wire is pierced or cracked. FIG. 8C provides a perspective view of the underside of a completed pluggable outlet assembly 65, depicting the GFI male contacts 79 and 79' extending through the base member 75 through openings 75a and 75b.

The stand-alone outlet 67 (see FIG. 7) differs from the pluggable outlet 65 in two respects. First there is no need to provide for a GFI module 77 and its associated reset button 78 in the stand-alone outlet. Second, the stand-alone outlet's base 75 does not need openings 75a and 75b as the stand-alone outlet does not interface directly with the conventional wiring system. In all other respects, the pluggable and stand-alone outlets are the same.

A single outlet base 75 may be configured with “punch out” openings 75a and 75b so that it may be used with either the pluggable or stand-alone outlet assemblies.

FIG. 8B is an alternate perspective view of the pluggable outlet unit 65, depicting the two sets of male contacts 81 and 83, which interface with the flat wire connector 76 and GFI module 77, respectively. Note that the flat wire connector 76 and GFI module 77 are not affixed to the base member 75, but are selectively connected to the outlet cover 74 by the male contacts 81 and 83.

Also depicted in FIG. 8B is copper frame 84 on the underside of cover 74. The copper frame 84 functions to provide conductive connections to female receptacles 72, 72', 73, and 73', and the two sets of male contacts 81 and 83. The male contacts 83 plug into corresponding slots 82 on one surface of the GFI module 77 as shown in FIG. 8A.

The flat wire connector 76, which is common to both the stand-alone and pluggable outlets, will now be discussed in greater detail. The flat wire connector 76 provides the connection point between the flat wires of the present invention and the copper outlet frame 84.

An example of such a “flat-wire to outlet frame” connector 90 is illustrated in the perspective view of FIG. 9A. While a 5-conductor connector assembly is shown for illustrative purposes, it is understood that the connector can be constructed to interface with any number of flat conductors having any number of copper layers.

Along one surface of connector 90 there is provided a plurality of flat wire receptacles 92 for receiving each of the flat wire conductors 11. The 3-conductor and 5-conductor electrical wires may use the same 5-conductor connector assembly 90, provided the outer wire receptacles are depopulated when the 3-conductor electrical wire is used. The other wire embodiments would have their own interface connectors 90. The need for multiple connectors does not pose a problem as the connectors can easily be swapped and inserted in the outlet cover 74 by plugging the connector into the male contacts 81 fixed to the outlet cover 74.

Each of the flat wire receptacles contains a plurality of slotted springs 94 for contacting the corresponding copper layers in each of the multi-layer conductors 11 (see FIG. 9B also). Two to five slotted springs 94 would generally be provided to correspond to the multi-layer copper conductor embodiments discussed above.

As shown in the perspective views in FIGS. 9A and 9E, and the side view in FIG. 9C, a plurality of elongated female slots 98 are contained on another surface of the connector 90. These elongated female slots 98 interface with the corresponding set of male contacts 81 as shown in FIG. 8B. The male contacts 81 merely slide into slots 98 to make the connection.

As more clearly seen in FIG. 9E, each of the extended slots 98 contain a series of wipers or brushes 98a–98d, each of which moves independently of the others, to provide a better connection and more surface contact with the male contacts 81.

The sequence of connecting the flat wire to the connector 90 is described with reference to an exemplary 5-conductor embodiment where each of the conductors has three copper layers. First, each conductor 11 is lined up with a respective flat wire receptacle 92. Then, each copper layer for each of the conductors 11 is inserted between the slotted springs 94. The slotted springs 94 are slightly biased by screws 96 as shown in FIG. 9D. By tightening the screws, one can ensure that both the top and bottom of each copper layer are in contact with the slotted springs. This ensures the best conductor contact, and also ensures that each copper layer (and thus each conductor) experiences the same resistance.

Finally, the male contacts 81 and extended female slots 98 are lined up and the connection to either the pluggable or stand-alone outlet is made. The outlet cover 74 would have a small cutout at the edge facing the flat wire receptacles 92 of connector 90 to enable the flat wires to pass through the outlet cover 74 to reach the connector 90.

In addition to the flat-wire to outlet frame connector, a second connector type is also needed to provide an interface

11

between conventional round wires and the various flat wire embodiments described above. This would occur, for example, where the flat wires connect to a wall light, fan, or intercom system.

An example of such a connector **100** is illustrated in the perspective view of FIG. **10A**, which depicts a 5-conductor flat-wire to conventional wire connector. While a 5-conductor connector is shown for illustrative purposes, it is understood that the connector can be constructed to interface with any number of flat conductors and any number of conventional round wires. The 3-conductor and 5-conductor electrical wires may use the same 5-conductor connector assembly **100**, provided the outer wire receptacles are depopulated when the 3-conductor electrical wire is used. The other wire embodiments would have their own interface connectors **100**.

As shown in FIG. **10A**, connector **100** contains a plurality of conventional set screws **101** along one surface of the connector to provide an interface for the standard "wire wrap" connections common in conventional round wiring systems (see FIG. **10B** also). Along another surface are placed one or more flat wire receptacles **102** for receiving each of the flat wire conductors. Each of the flat wire receptacles **102** contains a plurality of slotted springs **104** (see FIG. **10D** also) for contacting each of the layers in each of the multi-layer conductors. The slotted springs **104** are slightly biased by screws **96** as shown in FIGS. **10A** and **10C** and function in the same way as that described with respect to the connector **90**. Connection to the flat-wire receptacles by the flat wire conductors is the same as that discussed with regard to connector **90**.

FIG. **11A** depicts an improved three wiper female receptacle **110**, which may be incorporated into the pluggable **65** or stand-alone **67** outlets of the present invention.

Receptacle **110** contains cast copper leads **111** and **112** that contact the respective wiper assemblies **114** and **116**. Each of the wiper assemblies contains three wipers (**114a**, **114b**, **114c**; **116a**, **116b**, **116c**), each of which moves independently of the other two in the respective assembly.

The three-wiper receptacle **110** thus provides a better connection and more surface contact with the copper leads **111** and **112**. The other ends of copper leads **111** and **112** extend to the copper frame **84** (see FIG. **8B**). In addition, since the three wipers move independently, the receptacle is better able to accommodate torque in a plug.

Switches

A unique set of switches **124'** are provided for use with the wire products of the present invention. The switches may be electrically wired to an existing switch, or plugged into an existing outlet, or operated by radio frequency (RF) remote power. The switches are used mainly with the 3-conductor and 5-conductor wires, and under-surface lighting embodiments described above.

The switch mechanism may be front or side mounted (FIGS. **11B** and **11C**) and many switch variations are contemplated, including:

- (1) toggle controlled, permanent mount, discrete wired;
- (2) capacitive touch or membrane switch controlled, permanent mount, discrete wired;
- (3) capacitive touch or membrane switch controlled, permanent mount, radio frequency (RF) sender/receiver pair;
- (4) capacitive touch or membrane switch controlled, hand held or wall hung, RF sender/receiver pair; or

12

- (5) capacitive touch or membrane switch controlled full dimmer set with indicators, hand held or wall hung, RF sender/receiver pair.

Regardless of the particular type of switch utilized, however, all of the switches share certain common elements. The switches **124'** (see FIG. **12B**) do not switch the AC circuit. Rather, they send a signal, via a low voltage wire **125** (12 VDC) as shown in FIG. **12B**, to the corresponding plug that will switch the AC circuit.

If the switch unit is hardwired, it is coupled via voltage circuits. This makes the switches incapable of being used without a compatible plug unit.

Tools

The unique thin, flat wires of the present invention require equally unique insulation stripping tools to facilitate attachment to connectors and existing outlets. Each wire embodiment described above will have its own specialized tools.

Two versions are contemplated—one directed to use by professional electricians or installers and the other to non-professionals. The professional stripping tool is designed to cut and strip the insulation layer **17** off the conductors **11** in a single procedure similar to the manner of operating a conventional stripping tool. Considering the small thicknesses of the conductors, it is apparent that the stripping tool be precisely milled to allow for such precision cutting and stripping. Such precise milling may tend to raise the cost of such a tool, making it economically feasible for professional use only.

A second slicing tool directed to the non-professional will align the wire in the stripper and slice adjacent and perpendicular to the conductors, to allow the user to strip away the necessary insulation material to get to the conductive layers. The insulation is then peeled back and removed by scissors.

System Applications

A general illustrative system embodiment—incorporating the various wires, outlets, switches, and connectors described above—is shown in FIG. **12A**.

With reference to FIG. **12A**, there is provided a conventional outlet **120** and conventional switch **124**. A person desirous of wiring a ceiling fan **126** in the location shown would normally have to engage in an expensive wall and ceiling wiring job to bring electric current to the subject fan.

By utilizing the flat wires, outlets, switches, and connectors of the present invention, however, the task is greatly simplified as is now described. First a pluggable outlet **65** (FIG. **8A**) is plugged into the conventional outlet **120**. Next a stand-alone outlet **67** is fastened to the wall in the desired location. Lengths of flat wire **123** (e.g., 3-conductor or 5-conductor 110 VAC) are run between the pluggable outlet **65** and stand-alone outlet **67**, and again between stand-alone outlet **67** and the fan.

A connector **90** (not shown in FIG. **12A**, but is of the type depicted in FIG. **9A**) connects the flat wires **123** to the pluggable and stand-alone outlets **65** and **67**. In addition, another connector **100** (of the type depicted in FIG. **10A**) connects the conventional round wires of the fan **126** with the flat wire **123**.

The flat wire **123** is affixed to the wall surface with the adhesive layer **17** as described above, typically double sided tape, and either painted or papered over to obscure the wire.

As illustrated, the flexible, flat wire **123** incurs a 90 degree bend along its width at point **127** where the ceiling and wall adjoin, as the flat wire is adhered to a different planar sur-

13

face. In addition to bending at any angle along its width to accommodate different planar surface joints, the flexible wire may actually be bent back upon itself at any angle to accommodate angle changes on the same planar surface.

Consider, for example, the second wall lighting, apparatus **126'** in FIG. 12A. The wall light **126'** is connected to standard switch **124** by a flat wire **128**. For aesthetic reasons, rather than put a second stand-alone switch near the conventional switch, the flat wire is bent at a 45 degree angle at points **129** and **129'**. The flat wire is basically folded back upon itself to achieve the 45 degree turn.

FIGS. 13–17 are more specific diagrammatic representations of the various system embodiment using the flat wires previously disclosed. The systems are briefly described below.

FIG. 13 illustrates the flat wire/conventional loud speaker wire interface. For simplicity and ease of illustration, only one speaker **131** is illustrated with stereo **130**. It is understood that any number of speakers may be used with the flat wires of the present invention.

As illustrated, stereo system **130** is connected to speaker **131** via flat wires **133**. The speaker **131** can be placed in any desired location. The traditional speaker wires **136** are then connected to a stand-alone plug on the wall. A second stand-alone plug is placed in the desired location near the new speaker position. The flat wires **133** are then run between the two stand-alone plugs. The entire length of the flat wire **133** may then be painted or papered over, thereby eliminating unsightly and cumbersome speaker wire.

With reference to FIG. 14, there is shown a diagrammatic representation of the application of the flat wire/conventional phone jack interface for use in providing a connection to an extension phone.

As illustrated, the existing phone jack or phone receptacle **141** is connected to the extension phone jack **142** via flat wires **143**. As shown, a flat wire phone apparatus **147** is connected to the existing phone jack **141**. The extension phone jack **142** is then placed in the desired location and connected to flat wire phone apparatus **147'**. The flat wires **143** are then connected between the flat wire phone apparatuses **147** and **147'**. The entire length of the flat wire **143** may then be painted or papered over, thereby eliminating unsightly and cumbersome phone wire.

A diagrammatic representation of a CATV application is shown in FIG. 15. The cable input **151** is fed into the house via the 75 ohm coaxial cable **158**. The cable **158** is then connected to 75 ohm–300 ohm conversion apparatus **157** located on the wall near the input **151** into the house. A second conversion apparatus **157** is placed near the desired television **152** location. Flat wires **153** are then run between the two conversion apparatuses. As above, the entire length of the flat wire **153** may then be painted or papered over, thereby eliminating unsightly and cumbersome CATV wire.

The under surface lighting embodiment, including flat wires **163** with embedded lights **169**, is shown in FIG. 16. The switch or plug **161** is connected to the flat wire **163**. The embedded lights **169**, may be, for example, double-ended RSC base 120V halogen lamp from 20 to 100 watts. The flat wires can be placed in any under surface location where additional light is desired, such as under a cabinet or shelf. The flat wire **163** may then be painted or papered over to match the rest of the surface.

The flat wires of the present invention may also be used with direct current (DC) applications. With reference to FIG. 17, a DC source **171** is connected to a DC outlet **172**, via flat wires **173**. As in the other system embodiments, wall con-

14

nectors provide the interface between the conventional DC wires **158** and flat wires **153**.

Ground Fault Interruption (GFI) Circuit

Since the flat wire is nearly invisible after it is painted or papered over, there is a possibility that at some later date, a person could inadvertently drive a nail or picture hook through the flat wire, or otherwise cut the wire.

In each of the systems, therefore, a ground fault interruption (GFI) module(s) **77** (see FIGS. 8A–8C) will be provided as a safety measure to prevent injury should accidental penetration through the ultra thin layers of insulation occur. The term ground fault comes from anything or any person providing a ground path other than the normal internal ground.

The GFI circuit will monitor the current flow through the power and neutral conductors of the AC circuits, and if more than ten milliamperes of mismatch is sensed, then both conductors will be disconnected by a circuit breaker. The circuit breaker will be fast enough to prevent any permanently harmful discharge.

The circuits will provide a fail safe methodology such that any circuits will be checked before connection and rechecked after connection. Power from the circuit will provide connection so that a circuit failure will result in no power beyond the circuit breaker.

As described previously, the circuit is physically located in the “pluggable” outlet **65** (see FIGS. 8A–8C) that plugs into a conventional wall outlet as discussed above. The GFI detection circuit is basically a relay that is normally closed. When the fault current to ground exceeds some predetermined value that is less than that required to operate the overcurrent protective device of the supply circuit, the relay opens, interrupting the electric current to the load.

FIG. 18 illustrates a standard single circuit **180** non-switchable two-plug system having a GFI detection circuit connected to a 4-plug, 3-terminal apparatus in accordance with the present invention.

FIG. 19 illustrates a standard single circuit **190** non-switchable two-plug system having a GFI detection circuit connected to an 8-plug apparatus (4 main plugs and 4 extension plugs) in accordance with the present invention.

FIG. 20 illustrates a standard two circuit **200** switchable two-plug system, therefore requiring two GFI detection circuits, each connected a 4-plug apparatus (2 main plugs and 2 extension plugs) in accordance with the present invention.

While the invention has been described in terms of the embodiments described above, those skilled in the art will recognize that the invention can be practiced with modification within the spirit and scope of the appended claims.

Having thus described my invention, what I claim as new and desire to secure by Letters Patent is as follows:

1. A surface mountable, flexible, multi-purpose wiring comprising:

a plurality of flat, elongated conductors, each conductor having a width of 0.125 inches or more and comprising at least one conductive layer having a cross sectional height in the range of *about* 0.0004 to *about* 0.0200 inches;

a bonding material adjacent each said flat, elongated conductor; and

an insulation layer *selected from the group consisting of urethane, polyethylene and a fluoropolymer*, said insulating layer surrounding said plurality of flat, elongated conductors and said bonding material, said bonding material being bonded to said insulation layer,

15

wherein a combined cross-sectional height of said plurality of flat, elongated conductors, bonding material and insulation layer is less than *about* 0.050 inches,

wherein said plurality of flat, elongated conductors are separated by a distance in a range of *about* 0.125 and *about* 0.6 [inches.] inches, and

wherein the wiring may be folded back upon itself at any angle to accommodate angle changes on the surface of a wall or ceiling.

2. The multi-purpose wiring of claim 1, wherein opposite side edges of said insulation layer are tapered to allow said wiring to blend in with a surface to which said wiring is mounted.

3. The multi-purpose wiring of claim 2, wherein said wiring bears or accepts an adhesive tape, liquid or spray on either side of said wiring to adhere said wiring to a surface.

4. The multi-purpose wiring of claim 1, wherein said at least one conductive layer comprises at least one conductive metal layer.

5. A multi-purpose wire, comprising:

a plurality of elongated conductors, each conductor having a width of 0.125 inches or more and comprising at least one conductive layer having a thickness in a range of *about* 0.0004 to *about* 0.0200 inches;

a bonding material adjacent each said elongated conductor; and

an insulation layer selected from the group consisting of urethane, polyethylene and a fluoropolymer, said insulation layer surrounding said plurality of elongated conductors and said bonding material,

wherein a thickness of said wire is no greater than *about* 0.050 inches, and

wherein said plurality of elongated conductors are separated by a distance in a range of *about* 0.125 and *about* 0.6 [inches.] inches, and

wherein the multi-purpose wire may be folded back upon itself at any angle to accommodate angle changes on the surface of a wall or ceiling.

6. The multi-purpose wire of claim 5, wherein said plurality of elongated conductors comprises a plurality of conductors spaced apart in a generally parallel, coplanar relationship.

7. The wire according to claim 5, wherein each elongated conductor in said plurality of elongated conductors has a width in a range of *about* 0.125 to *about* 1.5 inches.

8. The wire according to claim 5, wherein each of said at least one conductive layer has a thickness in a range of *about* 0.001 to *about* 0.010 inches.

9. The wire according to claim 5, wherein said plurality of elongated conductors comprises a range of 1 to 6 conductors.

10. The wire according to claim 5, wherein said at least one conductive layer comprises a range of 1 to 5 conductive layers.

11. The wire according to claim 5, wherein said wire comprises a flexible wire.

12. The wire according to claim 5, wherein each of said at least one conductive layer has a uniform width and thickness.

13. The wire according to claim 5, wherein an application of said wire may be varied by varying one of a width of each elongated conductor in said plurality of elongated conductors, a height of each said elongated conductor, and a number of conductive layers in each said elongated conductor.

14. The wire according to claim 5, wherein said at least one conductive layer comprises a range of 3 to 5 conductive

16

layers, each conductive layer having a thickness of *about* 0.002 inches, and wherein said wire has a thickness of *about* 0.012 inches.

[15. The wire according to claim 5, wherein said insulation layer comprises one of polyester, urethane, polyethylene and a fluoropolymer.]

16. The wire according to claim 5, wherein said insulation layer is flexible, paintable, and resistant to ultraviolet light and joint compounds.

17. The wire according to claim 5, wherein said bonding material is bonded to an inner surface of said insulation layer.

18. The wire according to claim 5, wherein said bonding material comprises one of a thermal bonding material, adhesive tape, liquid adhesive [and] or a combination thereof.

19. The wire according to claim 5, wherein said bonding material separates said plurality of elongated conductors and maintains a safe dielectric distance between said elongated conductors.

20. The wire according to claim 5, wherein said plurality of elongated conductors comprises 3 conductors, wherein said at least one conductive layer comprises 3 conductive layers, each conductive layer having a thickness of *about* 0.002 inches, and wherein said thickness of said wire is in a range of *about* 0.007 to *about* 0.050 inches.

21. The wire according to claim 5, wherein said wire has a width in a range of *about* 2.0 and *about* 4.0 inches, wherein a thickness of said at least one conductive layer is in a range of *about* 0.0004 to *about* 0.0020 inches, and wherein a distance between said plurality of elongated conductors is in a range of *about* 0.2 to *about* 0.3 inches.

22. The wire according to claim 5, wherein said plurality of elongated conductors comprises an alternating current (AC) ground conductor, split or unified, an AC neutral conductor, and an AC power conductor.

23. The wire according to claim 5, wherein said wire comprises 110 V AC wire, wherein said plurality of elongated conductors comprises a range of 3 to 5 conductors, and wherein said at least one conductive layer comprises a range of 1 to 5 conductive layers.

24. The wire according to claim 23, wherein said plurality of elongated conductors comprises 2 AC neutral conductors, 2 AC power conductors and 1 AC ground conductor, and wherein said wire accommodates two circuits.

25. The wire according to claim 23, wherein said plurality of elongated conductors comprises 1 AC neutral conductors, 2 AC power conductors and 1 AC ground conductor, and wherein said wire accommodates two circuits.

26. The wire according to claim 23, wherein said plurality of elongated conductors comprises 1 AC neutral conductor, 1 AC power conductor and 1 AC ground conductor, and wherein said wire accommodates two circuits.

27. The wire according to claim 23, wherein said wire has a width in a range of *about* 3.5 and *about* 4.25 inches.

28. The wire according to claim 5, wherein said wire comprises 220 V AC wire, and wherein said plurality of elongated conductors comprises:

an AC neutral conductor and an AC power conductor, each having a width in a range of *about* 0.4 and *about* 0.6 inches; and

an AC ground conductor having a width in a range of *about* 0.2 and *about* 0.4 inches, and

wherein of said at least one conductive layer has a thickness of *about* 0.002 inches, wherein said thickness of said wire is in a range of *about* 0.012 to *about* 0.050 inches, wherein a distance between said plurality of elongated conductors is in a range of *about* 0.4 and

17

about 0.6 inches, and wherein a width of said wire is in a range of about 3.0 and about 3.5 inches.

29. The wire according to claim 5, wherein said wire comprises one of loud speaker wire, telephone wire, cable television wire, low voltage wire [and] or under-surface lighting wire.

30. The wire according to claim 5, wherein said plurality of elongated conductors are separated by a distance in a range of about 0.2 and about 0.3 inches.

31. *The multi-purpose wiring of claim 1, wherein each conductor comprises a plurality of conductive layers.*

32. *The multi-purpose wiring of claim 1, wherein the wiring is concealed on the surface of the wall or ceiling by paint or wallpaper.*

33. *The wire according to claim 5, wherein each conductor comprises a plurality of conductive layers.*

34. *A wire comprising:*

a plurality of conductors, each conductor having a width of about 0.125 inches or more and comprising at least one conductive layer having a thickness no greater than about 0.0200 inches;

a bonding material adjacent to said plurality of conductors; and

an insulation layer selected from the group consisting of urethane, polyethylene and a fluoropolymer, said insu-

18

lation layer surrounding said plurality of conductors and said bonding material, said bonding material being bonded to said insulation layer,

wherein said plurality of conductors are separated by a distance in a range of about 0.125 inches and about 0.6 inches, and

wherein the wire may be folded back upon itself at any angle to accommodate angle changes on the surface of a wall or ceiling.

35. *The wire of claim 34, wherein a total thickness of said plurality of conductors, said bonding material and said insulation layer is less than about 0.050 inches.*

36. *The wire of claim 34, wherein said at least one conductive layer has a thickness in a range of about 0.0004 inches to about 0.0200 inches.*

37. *The wire of claim 34, wherein a conductor in said plurality of conductors has a width in a range of about 0.2 inches to about 0.8 inches.*

38. *The wire of claim 34, wherein each conductor comprises a plurality of conductive layers.*

* * * * *