

US00RE42022E

(19) **United States**
(12) **Reissued Patent**
Pizzi

(10) **Patent Number:** **US RE42,022 E**
(45) **Date of Reissued Patent:** **Jan. 4, 2011**

(54) **INSULATED JUMPER IN PARTICULAR FOR
TERMINAL BLOCKS OF SWITCHBOARDS**

(75) Inventor: **Giordano Pizzi**, Milan (IT)

(73) Assignee: **Morsettitalia S.p.A.**, Milan (IT)

(21) Appl. No.: **12/370,105**

(22) Filed: **Feb. 12, 2009**

Related U.S. Patent Documents

Reissue of:

(64) Patent No.: **7,413,486**
Issued: **Aug. 19, 2008**
Appl. No.: **11/774,220**
Filed: **Jul. 6, 2007**

(30) **Foreign Application Priority Data**

Jul. 7, 2006 (IT) MI2006A1322

(51) **Int. Cl.**
H01R 11/09 (2006.01)

(52) **U.S. Cl.** **439/787**; 439/796

(58) **Field of Classification Search** 439/787,
439/796, 797, 798, 716, 723, 439, 521, 714,
439/710

See application file for complete search history.

(56) **References Cited**

U.S. PATENT DOCUMENTS

945,017 A	1/1910	Cole
2,045,847 A	6/1936	Fotsch
2,082,947 A	6/1937	Fotsch
2,900,618 A	8/1959	Geier
3,159,730 A	12/1964	Staffel
3,609,642 A	9/1971	Norden
3,665,376 A	5/1972	Paris et al.
3,751,579 A	8/1973	Nojiri
3,775,733 A	11/1973	Ege
3,840,781 A	10/1974	Brown
4,070,086 A	1/1978	Trafford
4,130,331 A	12/1978	Neff et al.

4,171,861 A	10/1979	Hohorst
4,203,200 A	5/1980	Wiebe
4,224,592 A	9/1980	Urani et al.
4,241,975 A	12/1980	Cooper, Jr.
4,330,164 A	5/1982	Pittman et al.
4,340,270 A	7/1982	Wilmes et al.
4,350,407 A	9/1982	Tong
4,365,396 A	12/1982	Baba et al.
4,391,485 A	7/1983	Urani
4,444,455 A	4/1984	Wiancko et al.
4,559,504 A	12/1985	Krec
4,693,533 A	9/1987	Szczesny et al.
4,795,997 A	1/1989	Fisher et al.

(Continued)

FOREIGN PATENT DOCUMENTS

DE	1842868 U	12/1961
DE	3339365 A1	5/1985
DE	3621071 A1	1/1987
DE	3629796 C1	12/1987
DE	3805158 A1	8/1989

(Continued)

OTHER PUBLICATIONS

European Search Report from EP08075059, dated, Aug. 24, 2009.

Primary Examiner—Hae Moon Hyeon

(74) *Attorney, Agent, or Firm*—Mintz Levin Cohn Ferris Glovsky and Popeo, P.C.; A. Jason Mirabito, Esq.

(57) **ABSTRACT**

Electrical connection jumper, in particular for terminal blocks of switchboards, comprising a conducting body extending in the longitudinal direction and a plurality of connector elements for electrical connection, which extend in the transverse direction from said conducting body, and an insulating body, integral with said conducting body, said insulating body comprising a longitudinally extending gripping part and pairs of lugs which extend therefrom in a substantially transverse direction and are able to contain partially said conducting body.

16 Claims, 1 Drawing Sheet

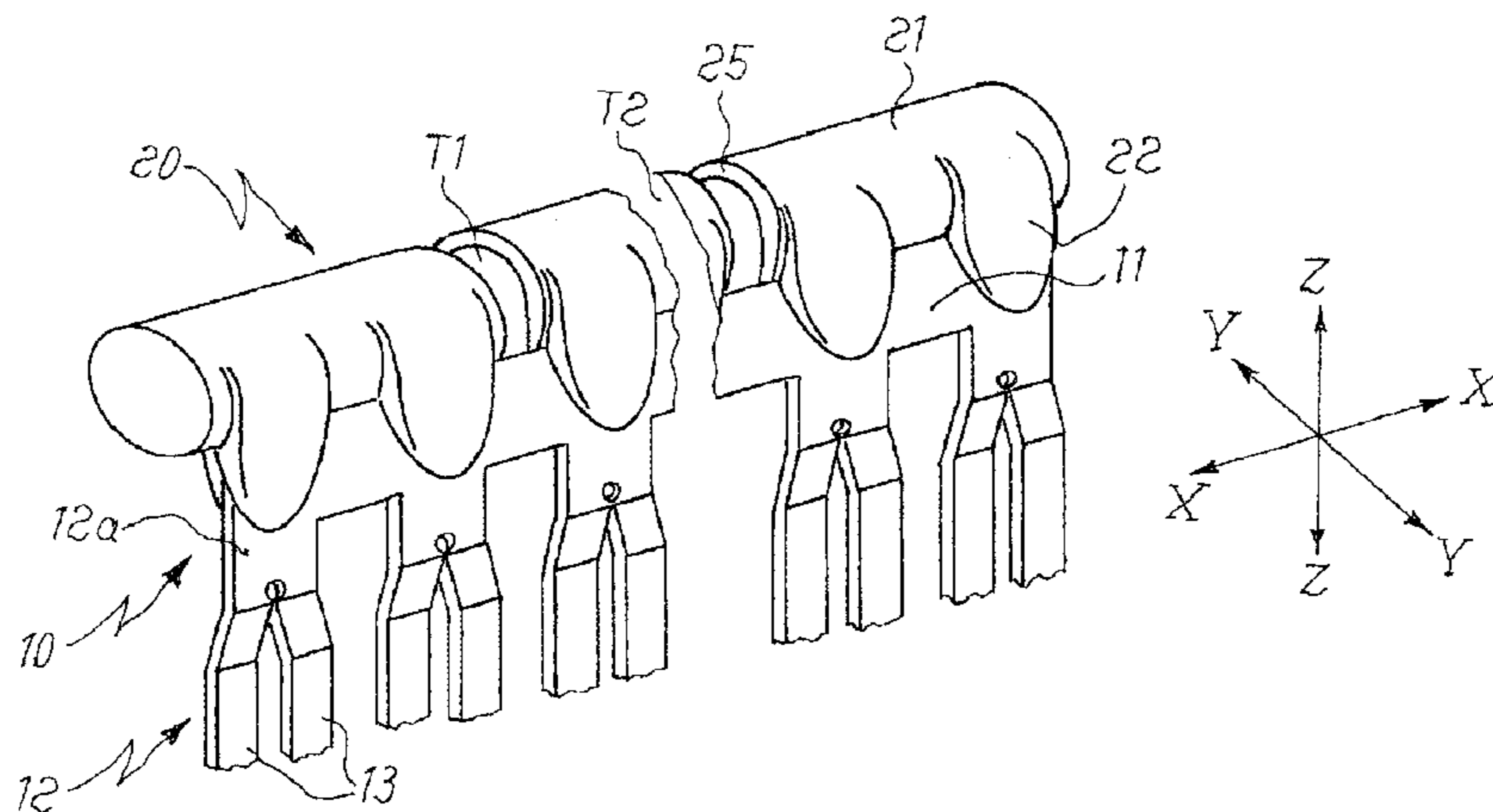

US RE42,022 E

Page 2

U.S. PATENT DOCUMENTS

4,889,504 A 12/1989 Barbier et al.
4,921,450 A 5/1990 Herbert
4,940,431 A 7/1990 Hennemann
5,002,505 A 3/1991 Jones et al.
5,030,131 A 7/1991 Boehm
5,243,139 A 9/1993 Law
5,276,280 A 1/1994 Ball
5,328,392 A 7/1994 Lin et al.
5,454,730 A 10/1995 Tozuka
5,553,787 A 9/1996 Guginsky
5,564,941 A 10/1996 Norden
5,766,044 A 6/1998 Norden
5,853,304 A 12/1998 Landreau et al.
5,860,837 A 1/1999 Bock et al.
5,905,230 A 5/1999 Marik
5,915,998 A 6/1999 Stidham et al.
6,004,167 A 12/1999 Hirakawa
6,157,287 A 12/2000 Douglass et al.
6,475,038 B1 11/2002 Franck
6,786,779 B2 9/2004 Feldmeier et al.
7,101,231 B2 9/2006 Prokup et al.
7,385,518 B2 6/2008 Torrez et al.
7,413,486 B2 8/2008 Pizzi
7,438,606 B2 10/2008 Pizzi
7,500,889 B2 3/2009 Pizzi
2002/0067279 A1 6/2002 Torrez et al.
2005/0042912 A1 2/2005 Drewes et al.
2005/0221665 A1 10/2005 Otto et al.
2006/0128232 A1 6/2006 Kim
2006/0148302 A1 7/2006 Patel et al.
2006/0189222 A1 8/2006 Bogiel et al.
2006/0228950 A1 10/2006 Jamaledin et al.

2007/0159292 A1 7/2007 Chang et al.
2008/0242150 A1 10/2008 Chikamatsu et al.

FOREIGN PATENT DOCUMENTS

DE 4223540 A1 1/1994
DE 4231244 A1 3/1994
DE 4409612 A1 9/1994
DE 19530947 A1 1/1997
DE 19542628 C1 2/1997
DE 19729327 C1 10/1998
DE 29821558 U1 3/1999
DE 29921080 4/2001
DE 10010719 C1 8/2001
DE 10324144 A1 2/2005
DE 102004018553 A1 11/2005
DE 202005005369 U1 3/2006
EP 0382999 8/1990
EP 0678934 A1 10/1995
EP 0893859 A2 1/1999
EP 1137034 A1 9/2001
EP 1137035 A1 9/2001
EP 1381068 A1 1/2004
EP 1531522 A1 5/2005
EP 1536519 A1 6/2005
EP 1630903 A1 3/2006
EP 1798821 A2 6/2007
EP 1860738 A1 11/2007
EP 1887658 A2 2/2008
FR 2259462 A1 8/1975
FR 2529024 A1 12/1983
FR 2637740 A1 4/1990
FR 2766628 A1 1/1999
GB 2342508 A 4/2000

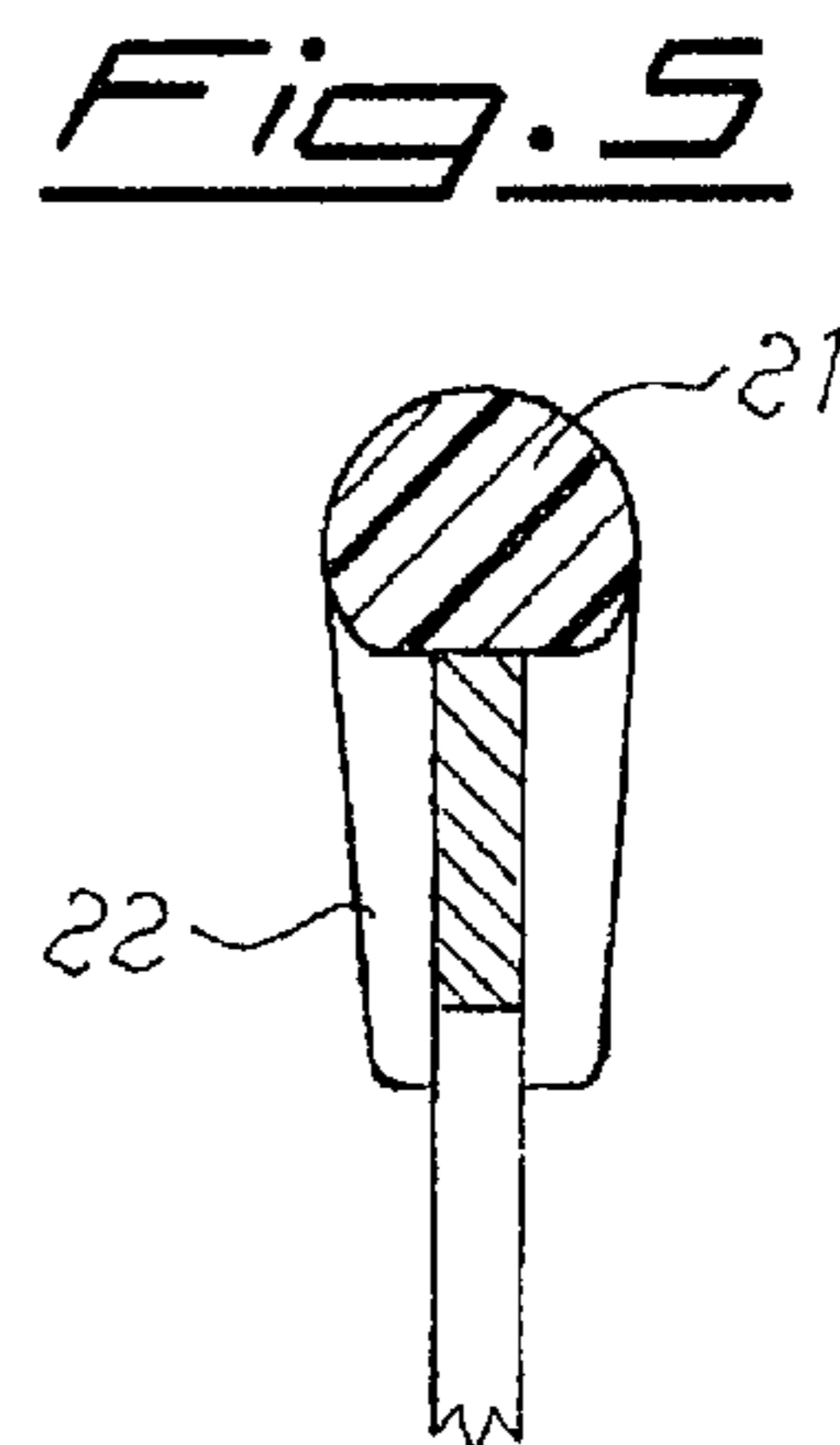
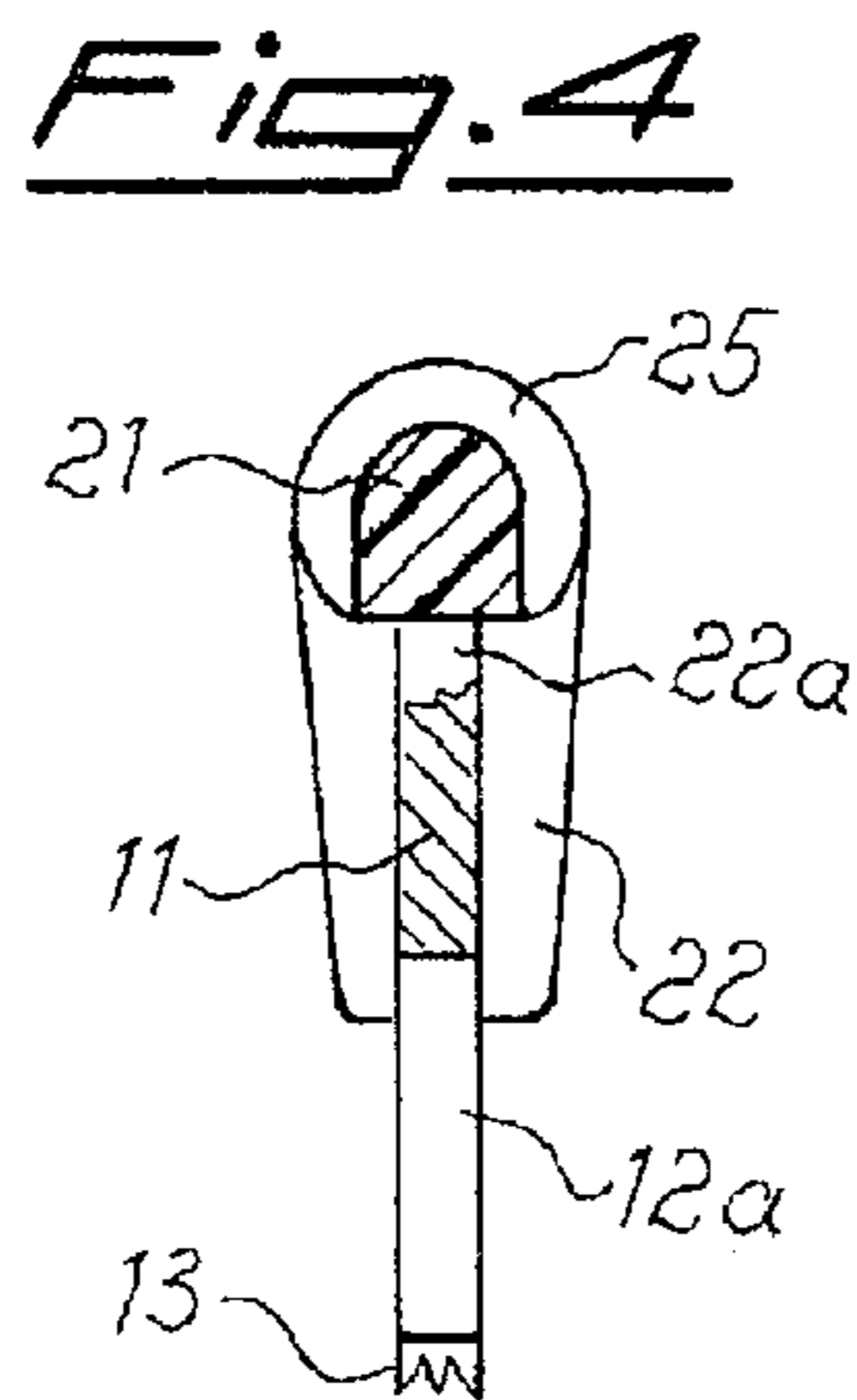
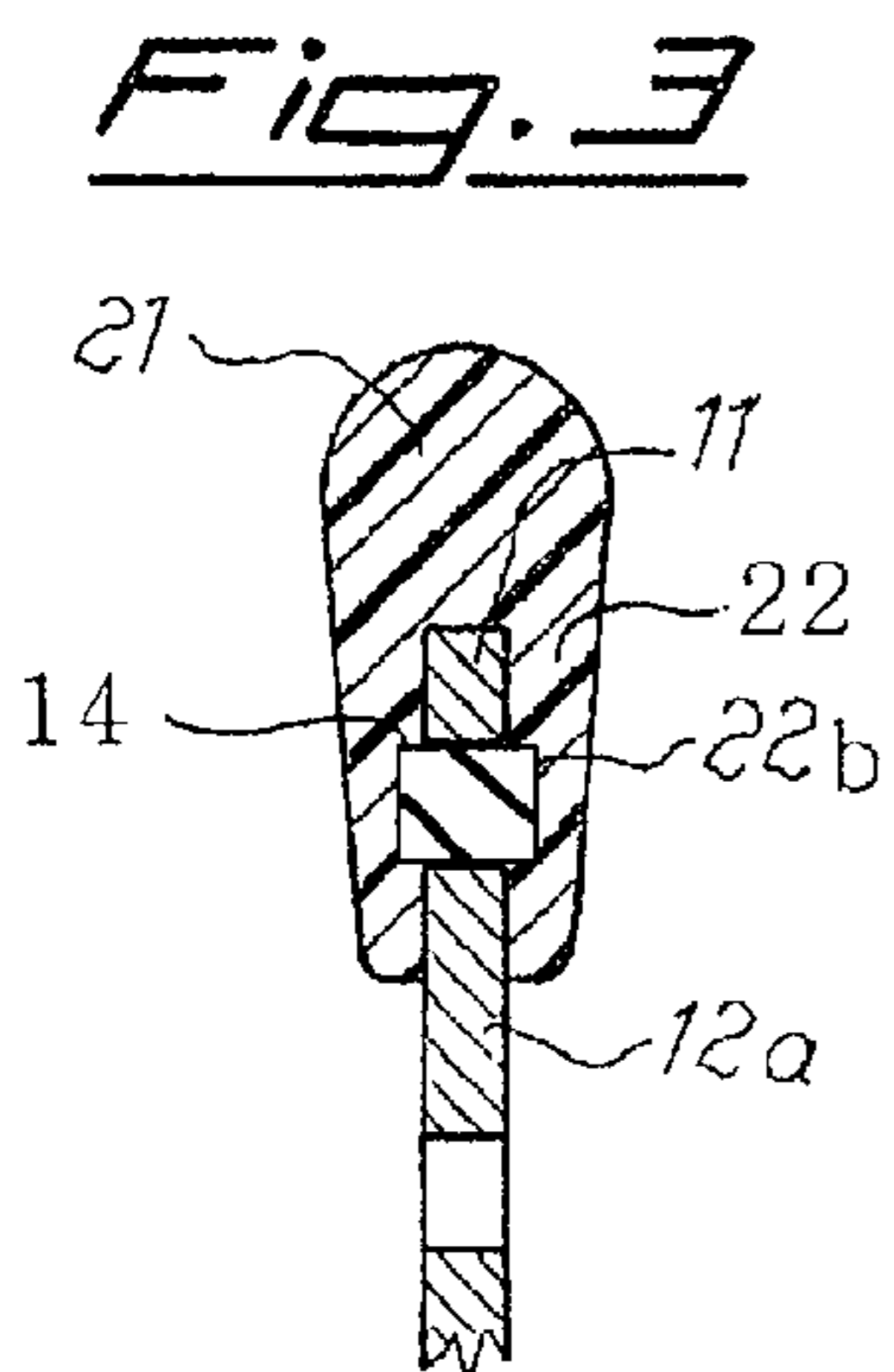
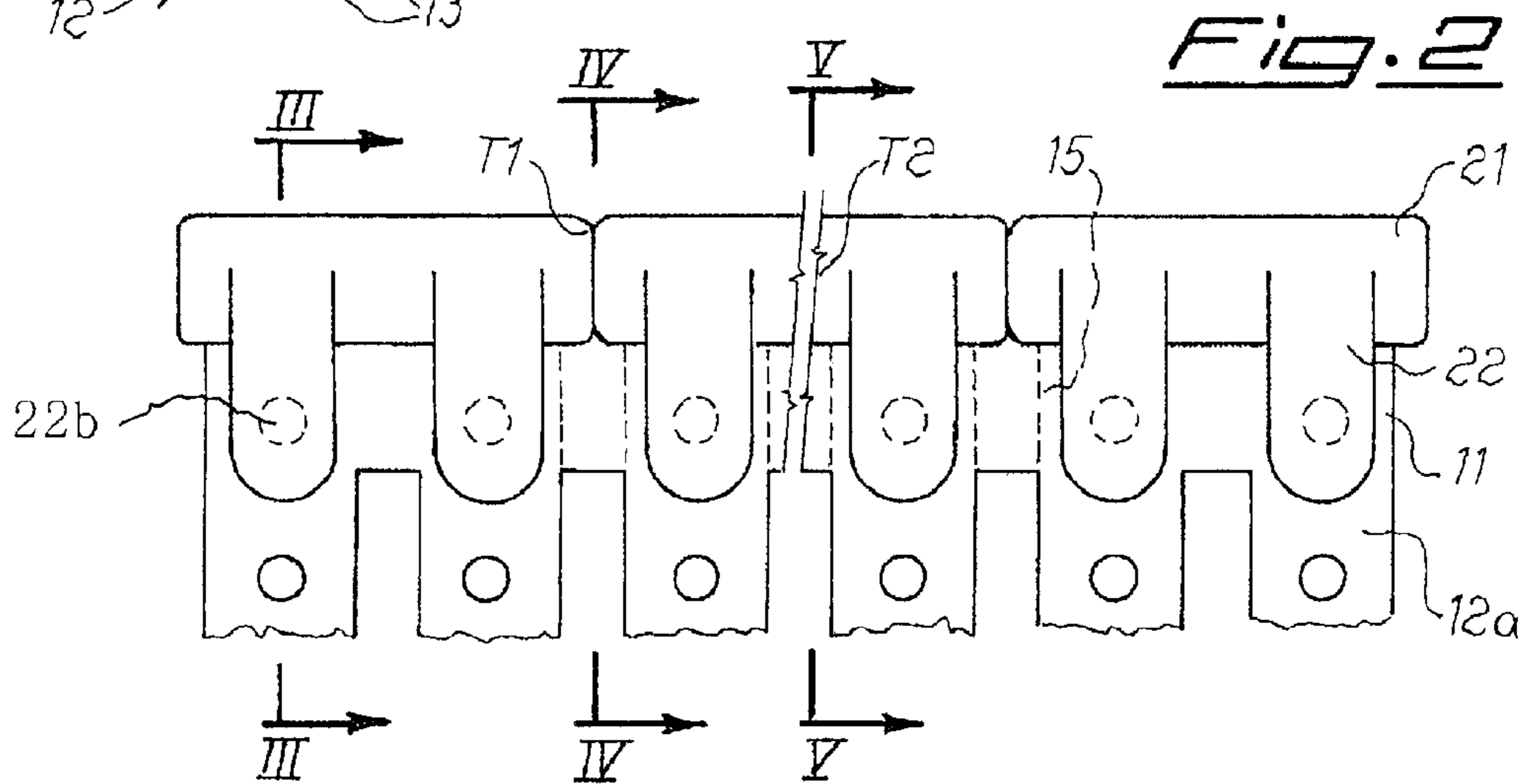
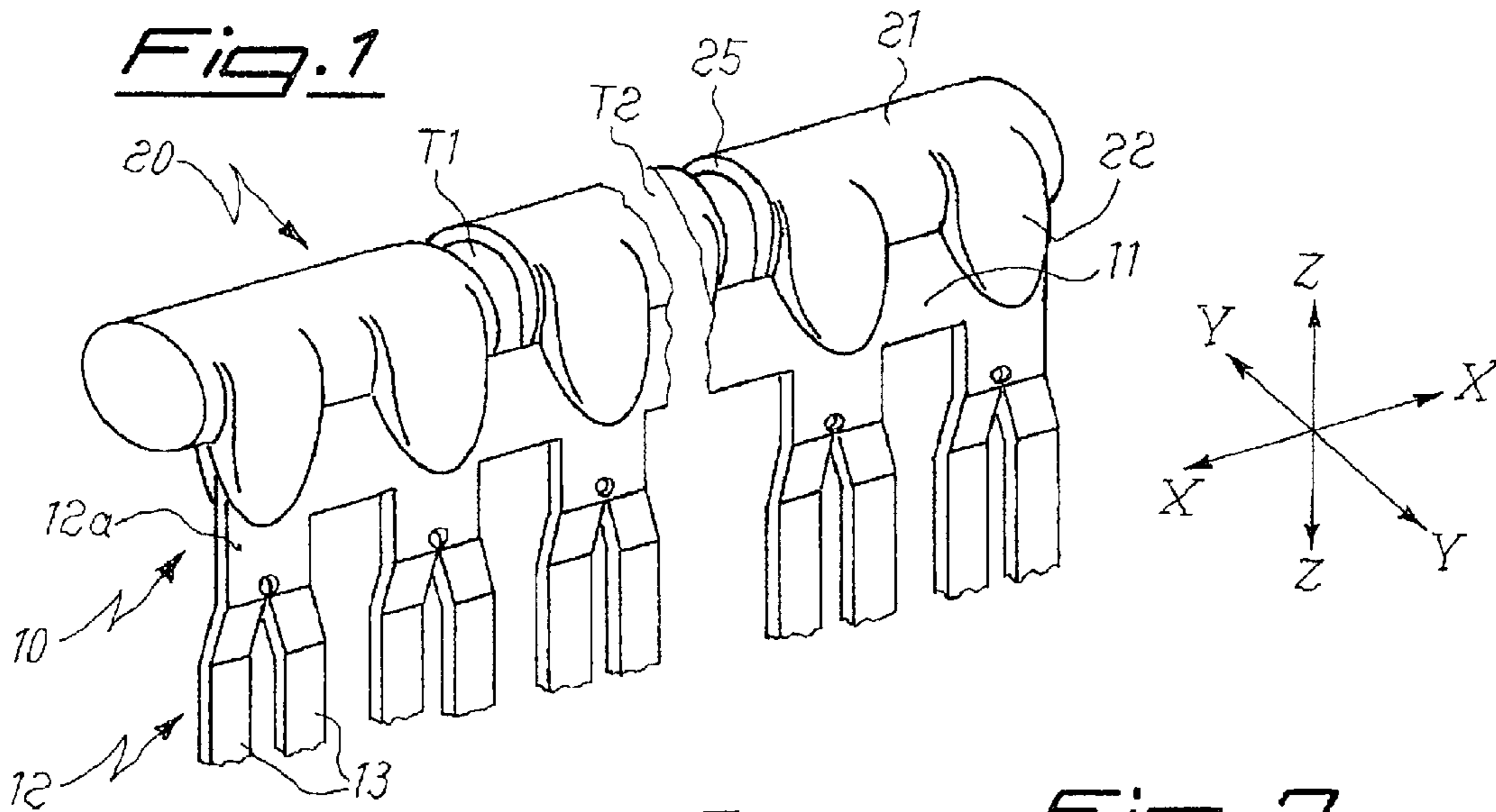

1

**INSULATED JUMPER IN PARTICULAR FOR
TERMINAL BLOCKS OF SWITCHBOARDS**

Matter enclosed in heavy brackets [] appears in the original patent but forms no part of this reissue specification; matter printed in italics indicates the additions made by reissue.

BACKGROUND

1. Technical Field of the Invention

The present invention relates to an insulated jumper in particular for terminal blocks of switchboards and the like.

2. Description of the Prior Art

It is known in the technical sector relating to terminal blocks for switchboards that there exists the need to connect together two terminals arranged alongside each other on the board in order to form the required electric circuit.

Jumpers made of conductive material and designed for this purpose are also known; said jumpers are formed by a conductive metal strip extending in a substantially longitudinal direction having, extending from it in a direction perpendicular to the above direction, flat pins formed in the manner of two resilient jaws able to form the part for engagement in the seat of the terminal block.

These known jumpers, although fulfilling their purpose, since they can be easily cut in the transverse direction in order to determine correct measurement in the longitudinal direction, have the drawback, however, that they cannot be electrically insulated with respect to the exterior, in particular at the time of use by a user; this results in a high risk of contact with the user him/herself and/or with foreign bodies and therefore injury both for the former, who may suffer an electric shock, and damage for the system which is short-circuited.

In order to solve the problem of insulation, jumpers are also known where the conductive strip is embedded in an insulating body; in this case also, however, there is the risk of drawbacks arising from the fact that cutting to size of the jumper is difficult owing to the double and different superimposed material, which requires complicated cutting operations using different tools respectively adapted to the type and thickness of material to be cut, making cutting practically impossible.

SUMMARY

The technical problem which is posed, therefore, is to provide electrical connection jumpers, in particular for terminals of switchboards, which are able to be cut to size and ensure perfect insulation of the visible conducting parts so as to prevent them from coming into contact with the user and/or with foreign bodies, causing short-circuits of the system.

In connection with this problem it is also required that this jumper should have small dimensions, be easy and inexpensive to produce and assemble and be able to be adapted easily at any user location using cutting means which are easy and inexpensive to provide.

These results are obtained according to the present invention by an electrical connection jumper, in particular for terminal blocks of switchboards and the like, comprising a conducting body extending in the longitudinal direction, a plurality of connector elements extending in the transverse direction from said conducting body, and an insulating body, integral with said conducting body, said insulating body comprising a longitudinally extending gripping part and pairs of oppositely arranged lugs which extend therefrom and are able to contain partially said connector elements.

2

BRIEF DESCRIPTION OF THE FIGURES

Further details may be obtained from the following description of a non-limiting example of embodiment of the subject of the present invention provided with reference to the accompanying drawings in which:

FIG. 1 shows a perspective view of a jumper according to the present invention, in its entirety;

FIG. 2 shows a side view of the jumper according to FIG. 1;

FIG. 3 shows a schematic cross-section along the plane indicated by III-III in FIG. 2;

FIG. 4 shows a schematic cross-section along the plane indicated by IV-IV in FIG. 2; and

FIG. 5 shows a schematic cross-section along the plane indicated by V-V in FIG. 2.

DETAILED DESCRIPTION OF PREFERRED
EMBODIMENTS

As shown in FIGS. 1 and 2 and assuming solely for the sake of convenience of the description and without a restrictive meaning, a set of three reference axes with a longitudinal direction X-X, transverse direction Y-Y and vertical direction Z-Z, respectively, the jumper for terminal blocks of switchboards according to the present invention comprises essentially: a conducting body **10** extending in the longitudinal direction X-X in the form of a thin strip **11** which has suitable dimensions for the electric load envisaged, and a plurality of connector elements **12** which extend in the transverse direction Y-Y from said strip **11** and are formed by a neck **12a** which is extended by one or more (two in the example of the figure) flat pins **13** for connection to the terminal (not shown).

The conducting body **10** is integrally joined to an insulating body **20** comprising a substantially continuous, longitudinally extending gripping part **21** which, in the example shown in the figure, has a circular cross-section with, extending from it, pairs of lugs **22** symmetrically arranged opposite each in the transverse direction Y-Y and aligned with each other in the longitudinal direction at a constant interval.

The lugs **22** of each pair are suitably spaced from each other in the transverse direction Y-Y so as to form a respective seat **22a** in the vertical direction, such as not to penetrate into the gripping part **21** of the longitudinally extending insulating body **20**.

As shown in FIG. 3, said lugs **22** have pins **22b** extending in the transverse direction Y-Y and suitable for engagement with a corresponding seat **14** open in the transverse direction in the neck **12a** of the conducting part **10**.

In this way the connection between conducting body **10** and insulating body **20** ensures that the gripping part **21** of the said insulating body is free of electrical conduction.

Advantageously this connection is obtained by overmoulding the insulator onto the conducting body.

It can also be seen how, at the opposite ends, the insulating body always projects in the longitudinal direction X-X beyond the conducting body, thus ensuring insulation of the jumper with respect to the user.

This configuration provides numerous advantages compared to the prior art since, when the jumper is cut to size, it will be possible to cut separately the insulating material and the conducting strip, thus ensuring the ease of cutting using conventional tools.

In addition to this, cutting may be performed both in a position T1 predisposed for cutting (FIG. 4) by means of an

3

annular undercut **25** of the gripping part and in a position **T2** which is not predisposed for cutting (FIG. **5**), while keeping, however, the gripping part totally insulated.

Said predisposed cutting zone **T1** or non-predisposed cutting zone **T2** is situated between two pairs of lugs **22** which are adjacent in the longitudinal direction, and the vertical cutting plane of the conducting part is inset in the longitudinal direction with respect to the cutting plane of the insulating body; correspondingly cutting of the conducting body **10** produces zones **15** where the conductor is inset in the longitudinal direction with respect to the cutting zone **T1/T2** of the gripping part **21**; in this way, since it is possible to obtain a free conducting edge which is set back from the insulating body, the risks of contact with the conducting part are reduced considerably.

Although illustrated and described in relation to a strip extending longitudinally as appropriate and to be cut, subsequently, to size, it is envisaged also that the jumper may be designed in modular form with a single connection body, with two or more bodies, or with a non-uniform succession of cutting zones determined by the alternating arrangement of jumpers with one, two or three, etc. connections.

Although not shown, it is envisaged moreover that the electrical connection part **13** may be formed with a screw element and/or clamp element as required and/or appropriate.

It can therefore be seen how with the electrical connection jumper for switchboard terminal blocks according to the present invention it is possible to achieve easily the production and/or cutting to size of the jumper and at the same time insulation of the gripping part which no longer contains the conducting part.

The invention claimed is:

1. An electrical connection jumper for terminal blocks of switchboards, comprising a conducting body extending in a longitudinal direction and a plurality of connector elements for electrical connection, which extend in a transverse direction from said conducting body, and an insulating body, integral with said conducting body, wherein said insulating body comprises a longitudinally extending gripping part and pairs of lugs which extend there from in a substantially transverse direction and partially contain said conducting body, wherein the pairs of lugs are spaced from each other in the transverse direction so as to form a respective seat for the conducting body.

2. The jumper according to claim **1**, wherein said gripping part of the insulating body is continuous.

4

3. The jumper according to claim **1**, wherein said lugs are arranged symmetrically opposite each other in the transverse direction.

4. The jumper according to claim **1**, wherein a depth in the vertical direction of said seat formed by the lugs is such as not to penetrate into the gripping part of the insulating body extending longitudinally.

5. The jumper according to claim **1**, wherein the conducting body includes at least one neck and at least one connection element extending from each neck.

6. The jumper according to claim **5**, wherein said lugs have at least one pin extending in a transverse direction and engaging a seat which is open in the transverse direction in the neck of the conducting body.

7. The jumper according to claim **6**, wherein said connection element comprises one or more flat pins which extend in the transverse direction from said neck for connection to a switchboard terminal.

8. The jumper according to claim **6**, wherein said connection element comprises screw means which extend in the transverse direction from said neck for connection to a switchboard terminal.

9. The jumper according to claim **6**, wherein the lugs are partially overmoulded onto the neck of the conducting body.

10. The jumper according to claim **6**, wherein the neck is formed as a strip of suitable length in the longitudinal direction.

11. The jumper according to claim **1**, wherein the insulating body is overmoulded onto the conducting body.

12. The jumper according to claim **1**, wherein said gripping part of the insulating body has at least one annular undercut that defines a cutting zone of the gripping part that is predisposed for transverse cutting.

13. The jumper according to claim **12**, wherein said cutting zone is situated between two pairs of lugs adjacent in the longitudinal direction.

14. The jumper according to claim **12**, wherein a vertical cutting plane of the conducting body is aligned in the longitudinal direction with respect to the cutting zone of the gripping part.

15. The jumper according to claim **1**, wherein said pairs of lugs symmetrically arranged opposite each other in the transverse direction are spaced from each other in the longitudinal direction at a constant interval.

16. The jumper according to claim **1**, wherein the opposite ends of the insulating body project in the longitudinal direction with respect to the conducting body.

* * * * *