

US00RE42010E

(19) **United States**
(12) **Reissued Patent**
Tseng

(10) **Patent Number:** **US RE42,010 E**
(45) **Date of Reissued Patent:** ***Dec. 28, 2010**

(54) **INSTALLATION FOR INCREASING USABLE RANGE ALONG AXIAL DIRECTION OF LIGHT SOURCE**

(76) Inventor: **Jen-Shou Tseng**, No. 205, Sec 1 Hengshan St., Hengshan Township, Hsinchu County 312 (TW)

(*) Notice: This patent is subject to a terminal disclaimer.

(21) Appl. No.: **11/267,887**

(22) Filed: **Nov. 4, 2005**

Related U.S. Patent Documents

Reissue of:

(64) Patent No.: **6,643,036**
Issued: **Nov. 4, 2003**
Appl. No.: **09/562,680**
Filed: **May 2, 2000**

(30) **Foreign Application Priority Data**

Dec. 18, 1999 (TW) 88222561 U

(51) **Int. Cl.**
H04N 1/04 (2006.01)

(52) **U.S. Cl.** **358/475; 358/296; 358/474**

(58) **Field of Classification Search** **358/474-475, 358/487, 496, 296, 512; 250/208.1, 226; 359/885; 257/59, 434, 435**

See application file for complete search history.

(56) **References Cited**

U.S. PATENT DOCUMENTS

5,300,767	A	*	4/1994	Steinle et al.	250/208.1
5,463,229	A	*	10/1995	Takase et al.	257/59
6,046,826	A	*	4/2000	Lu et al.	358/475
6,213,607	B1	*	4/2001	Watanabe et al.	359/601
6,233,063	B1	*	5/2001	Bernasconi et al.	358/474
6,411,594	B1	*	6/2002	Yamazaki	369/282
6,614,561	B1	*	9/2003	Tseng	358/474
6,614,581	B2	*	9/2003	Anderson	359/295
6,643,036	B1	*	11/2003	Tseng	358/475

* cited by examiner

Primary Examiner—Houshang Safaipoor

(74) *Attorney, Agent, or Firm*—Stolowitz Ford Cowger LLP

(57) **ABSTRACT**

An installation for increasing the usable range along the axial direction of a light source. The installation has a light source and an optical sensor. The light source generates a sense image. The optical sensor further has a sensor and a transparent panel. The sensor is responsible for detecting the image generated by the light source so that a sense image is created. The transparent panel is positioned between the sensor and the light source. A coating on the transparent panel modifies the light transparency along the axial direction of the light source such that light transparency is lower in the middle compared with the ends.

36 Claims, 2 Drawing Sheets

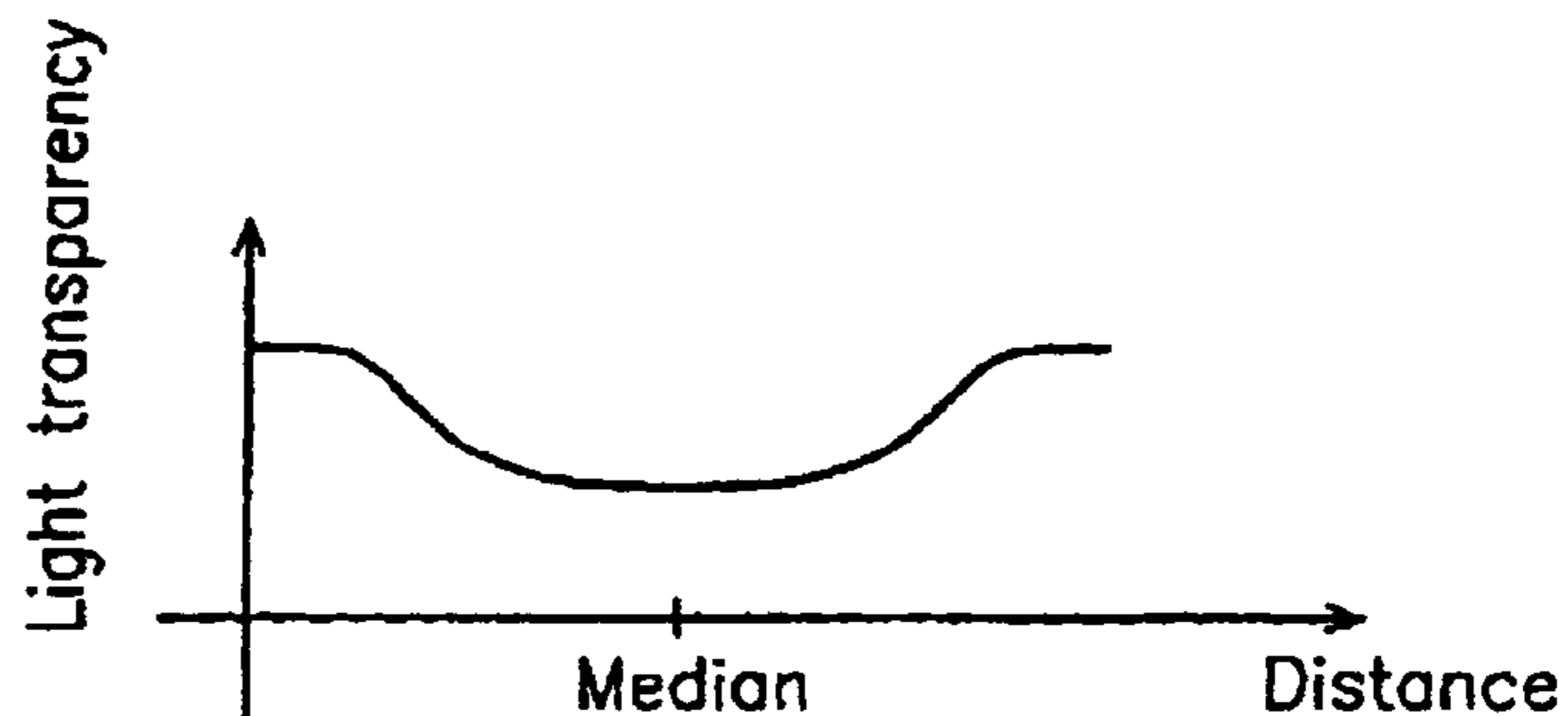
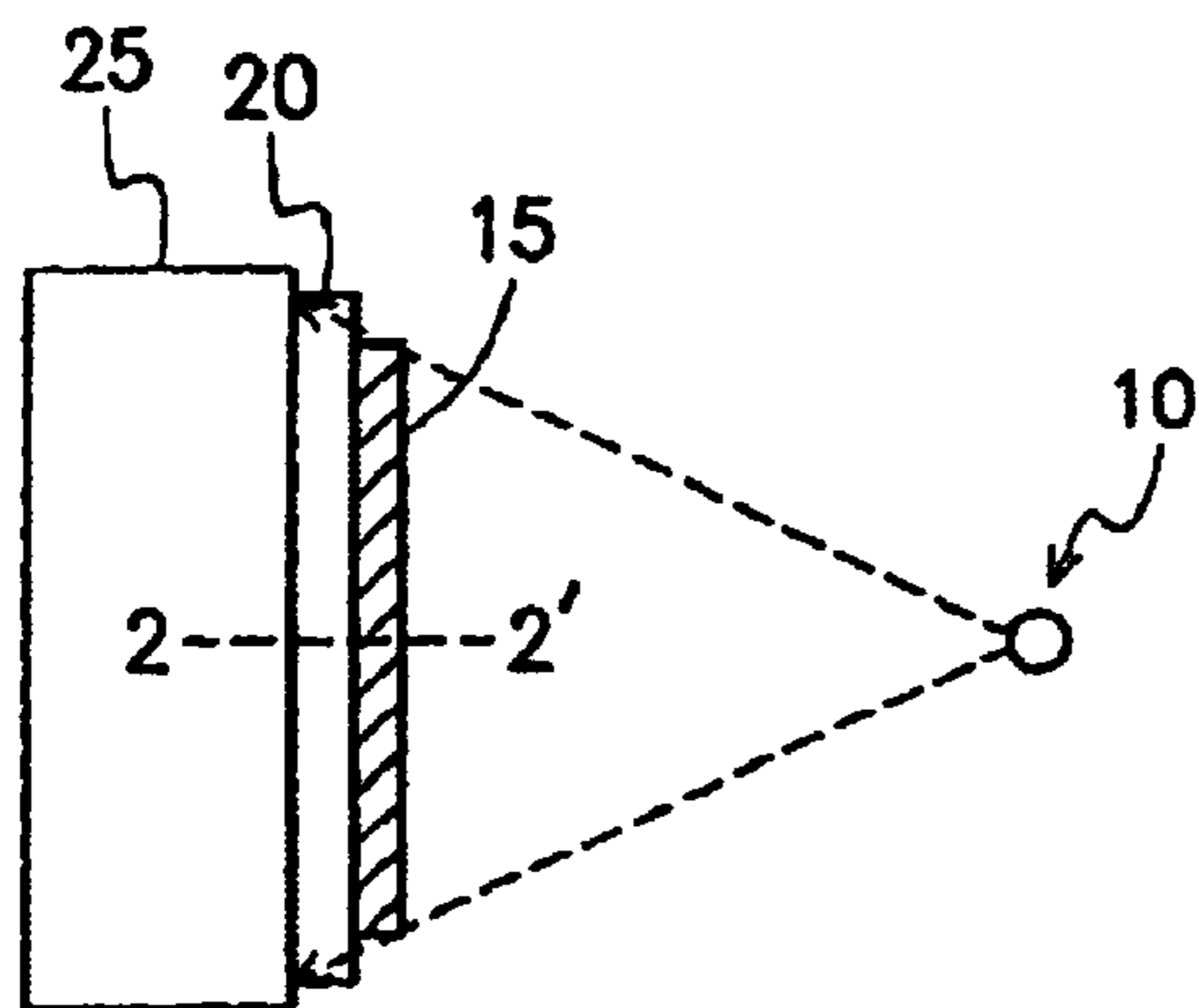

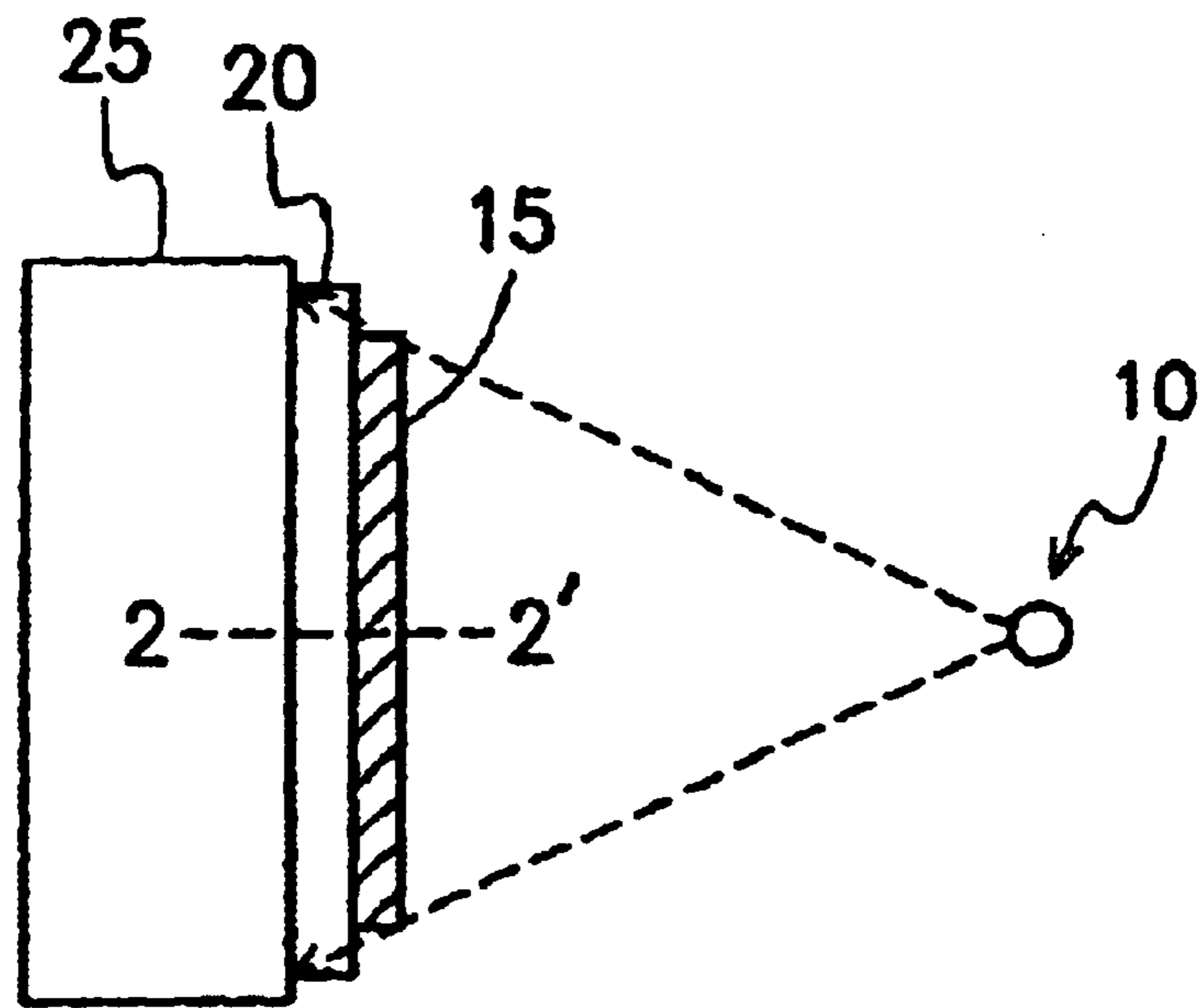

FIG. 1

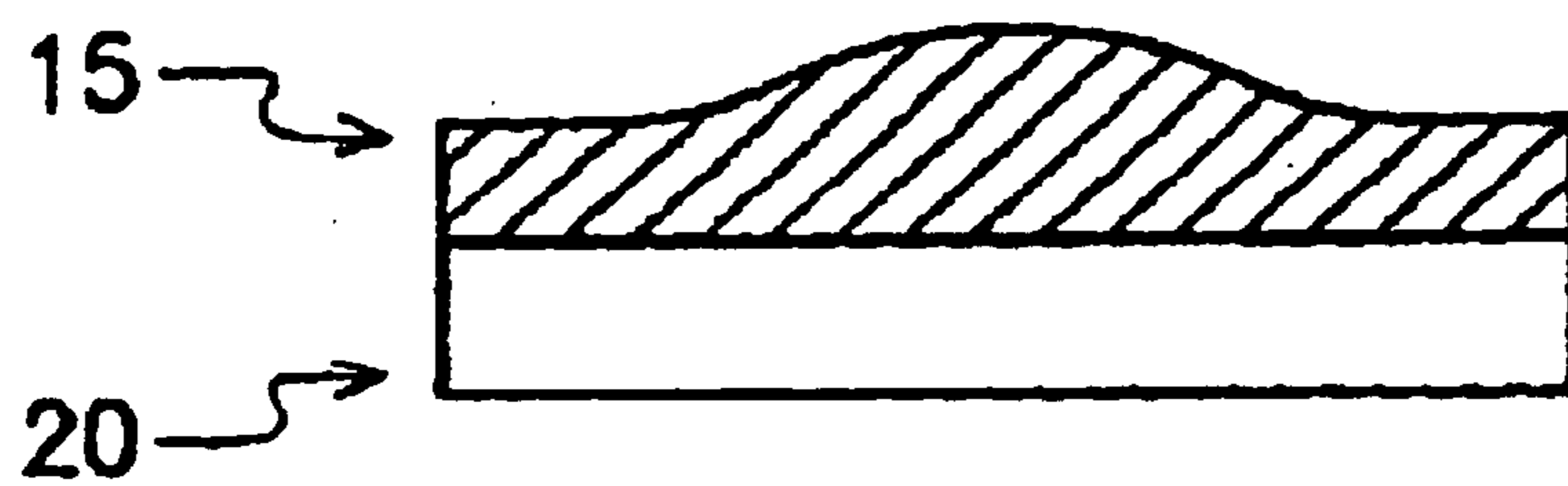

FIG. 2a

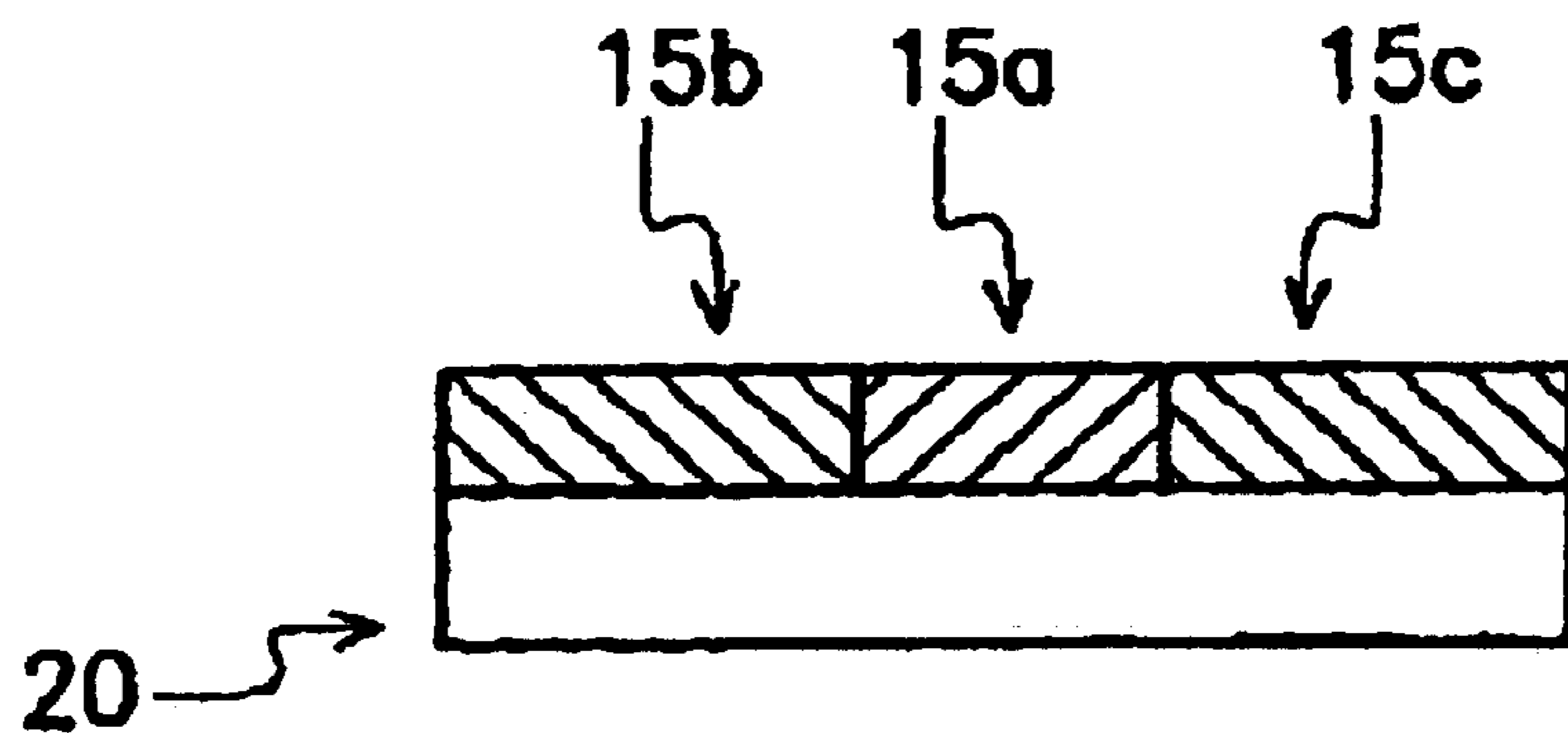

FIG. 2b

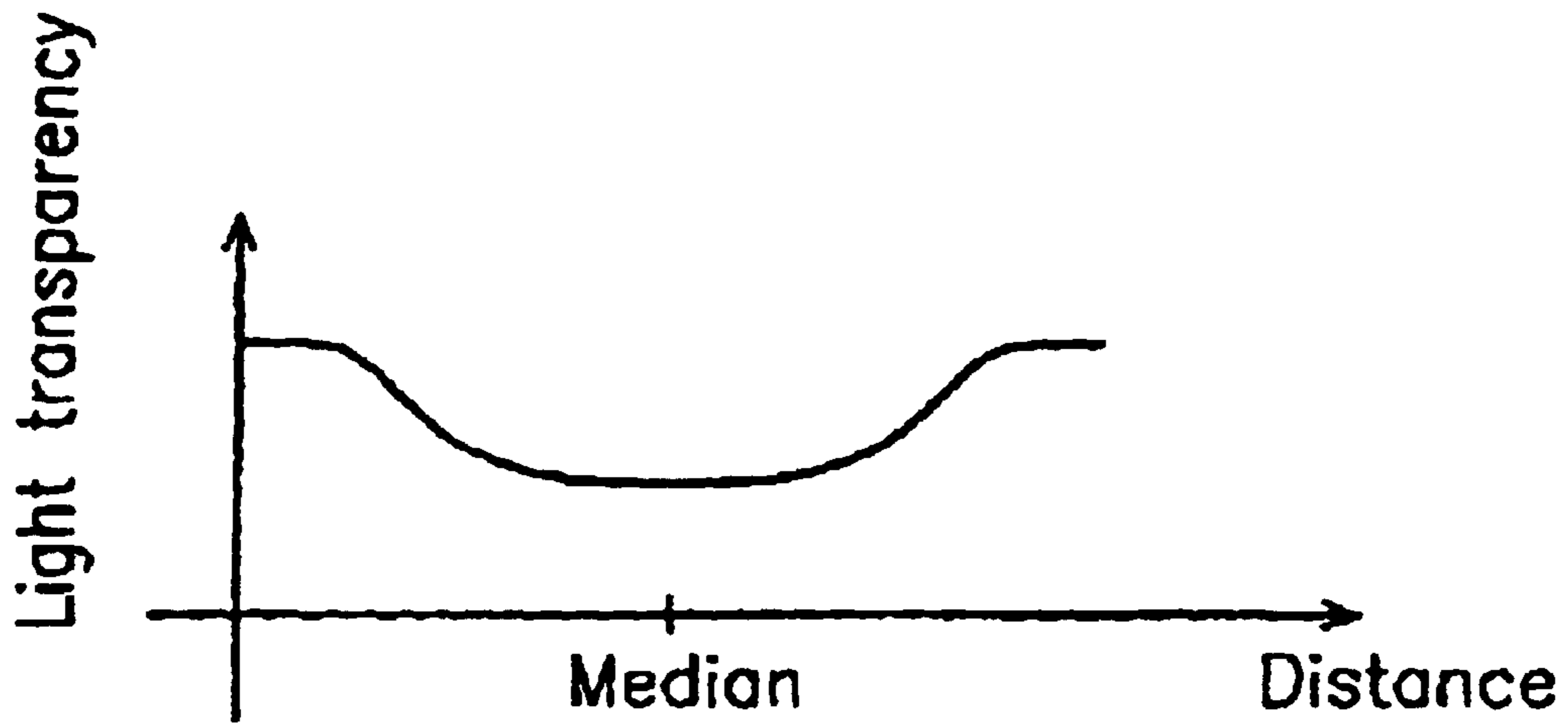

FIG. 3a

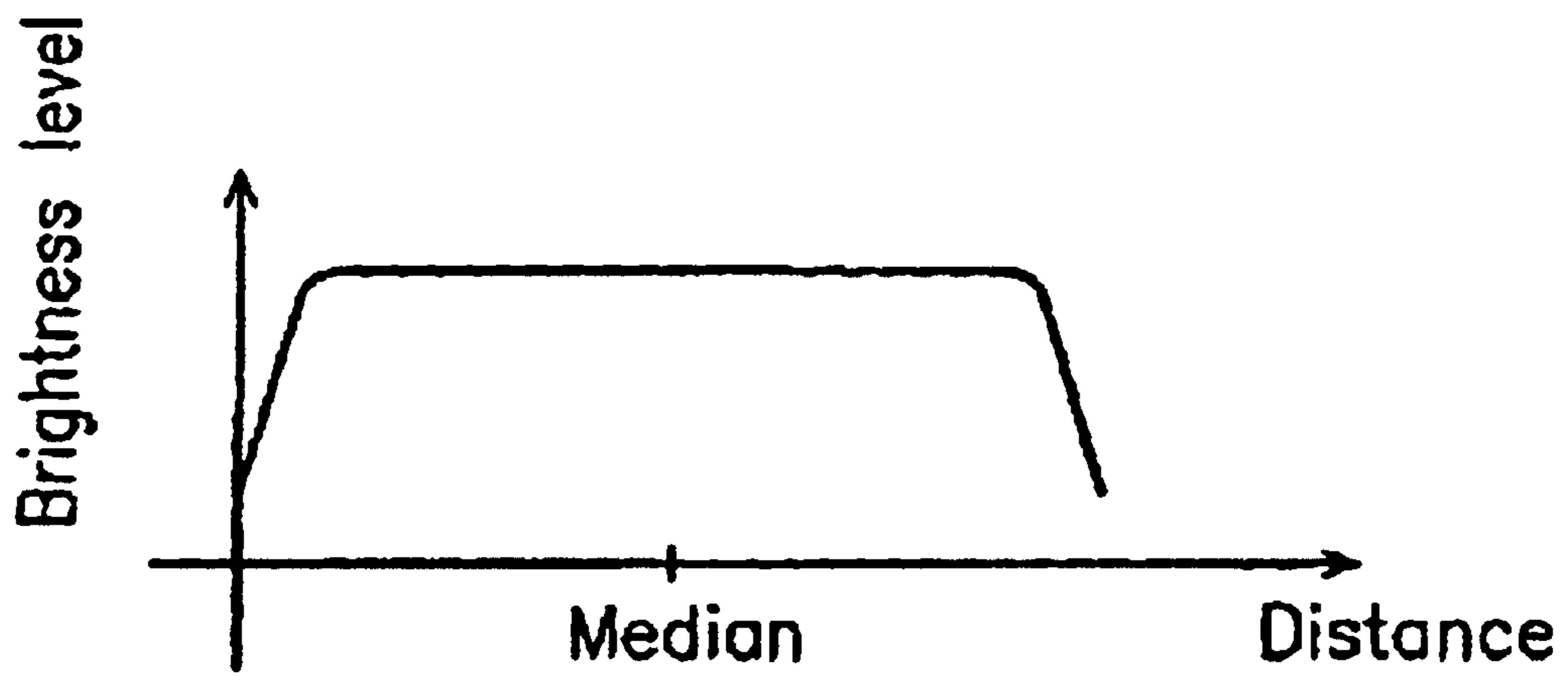

FIG. 3b

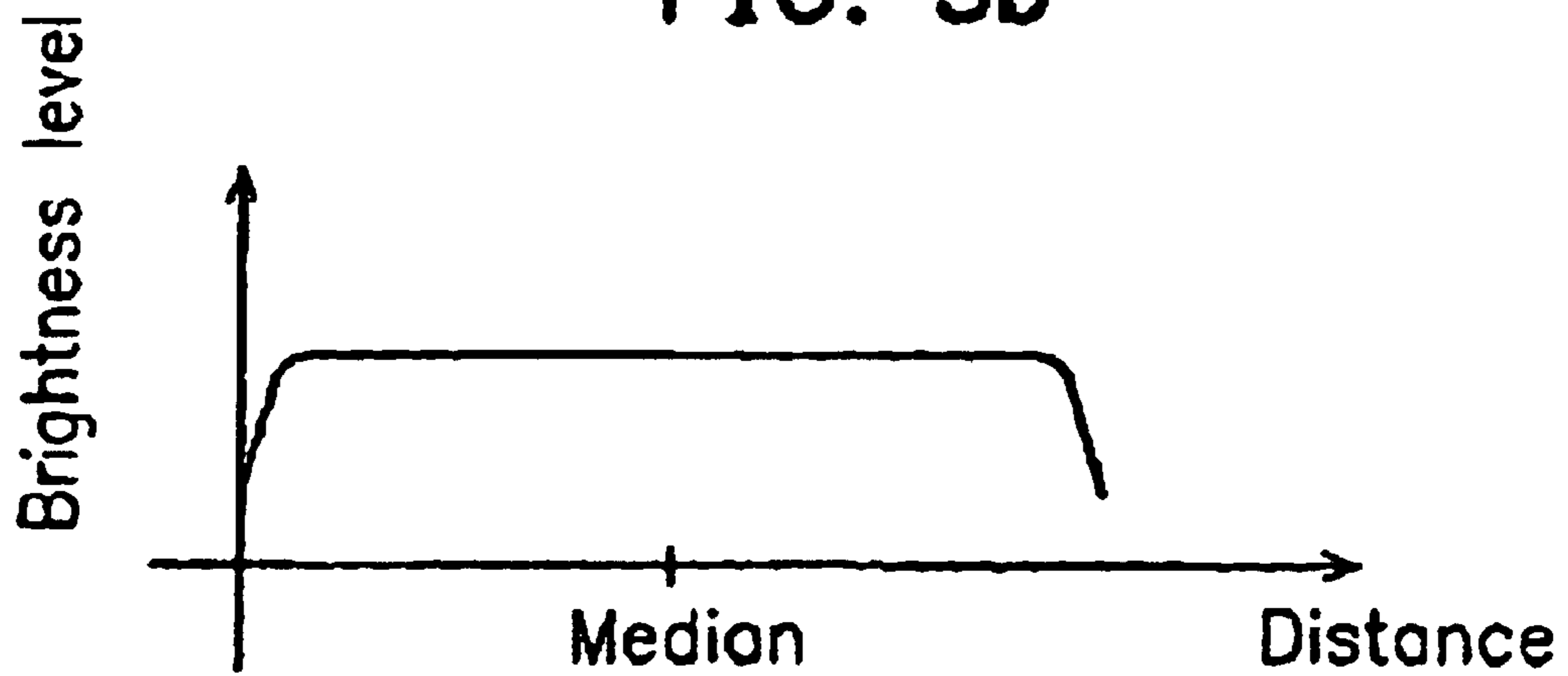

FIG. 3c

**INSTALLATION FOR INCREASING USABLE
RANGE ALONG AXIAL DIRECTION OF
LIGHT SOURCE**

Matter enclosed in heavy brackets [] appears in the original patent but forms no part of this reissue specification; matter printed in italics indicates the additions made by reissue.

CROSS-REFERENCE TO RELATED
APPLICATION

This application claims the priority benefit of Taiwan application serial no. 88222561, filed Dec. 18, 1999.

BACKGROUND OF THE INVENTION

1. Field of Invention

The present invention relates to an installation capable of increasing the usable range of a light source. More particularly, the present invention relates to an installation capable of increasing the usable range along the axial direction of a light source.

2. Description of Related Art

The operating principles of most image-extraction instruments, such as scanners and digital cameras, are very similar. Common features of image-extraction instruments include the use of a light source to produce an optical image and the passing of an optical image through an optical transmission system to an optical sensor. In general, the optical sensor is a charge couple device (CCD).

However, the longitudinal light source of a scanner has one major drawback, namely, brightness level along the central portion of the light axis is usually higher than along the adjacent sides. Hence, an image produced by the light source is brighter in the middle while dimmer along the edges. Since a scanner depends on brightness contrast to operate, a conventional scanner has poorer contrast near the two edges of the light axis. To preserve quality of the scan image, a section near the edge regions is often unused.

Hence, reducing brightness level variation along the axial direction of a light source has become one of the major improvement targets. For example, in Taiwan patent publication no. 244013 entitled 'Improved lamp shade compensation of an optical scanner', brightness variation along the light axis is improved by modifying the lamp shade structure. However, the invention requires specially made components, and hence may lead to an increase in production cost.

In Taiwan patent publication no. 352886 entitled 'A lens structure and its integration with an image-reading device', another method of improving brightness level along the axial direction of a light source is proposed. By changing the degree of reflectivity of a coated film on the reflecting lens inside the scanner, brightness level variation is reduced. However, the reflectivity of more than one reflecting lens needs to be modified, thereby increasing the production cost necessary for achieving the results. In addition, the method is not suitable for other optical sensing devices besides a scanner.

SUMMARY OF THE INVENTION

Accordingly, one object of the present invention is to provide an installation for increasing the scanning range along the axial direction of a light source by changing the light transparency of the transparent panel leading, to an optical sensor. In addition, the installation can be applied to other optical devices besides a scanner, such as a digital camera.

To achieve these and other advantages and in accordance with the purpose of the invention, as embodied and broadly described herein, the invention provides an installation for increasing the scanning range of a light source. The installation includes a light source and an optical sensor. The light source is used as a source for generating the image to be detected. The optical sensor includes a sensor and a transparent panel. The transparent panel is positioned between the sensor and the light source. Furthermore, the transparent panel also has a long axis that runs from edge to edge passing through the panel. The sensor receives an optical image formed by projecting light from the light source through the transparent panel. There is a coating over the transparent panel such that light transparency in the middle section of the long axis is higher than either side.

The coating can be deposited over the entire transparent panel. The coating can be deposited over the imaging section on the transparent panel only. In addition, the coating can be made by forming a plurality of coating materials of the same thickness over surface regions of the transparent panel so that a range of light transparencies are obtained across the panel. Conversely, a coating made from a single material but having a variable thickness is formed across the transparent panel to obtain a range of light transparencies across the panel.

In this invention, a coating is added onto the transparent panel of an optical sensor so that light transparency varies across the panel. Hence, there is no need to produce or modify components. Therefore, this invention is able to improve brightness variation of a light source with only minimum modification of the components. In addition, the installation can be applied to other optical devices besides a scanner, such as a digital camera.

It is to be understood that both the foregoing general description and the following detailed description are exemplary, and are intended to provide further explanation of the invention as claimed.

BRIEF DESCRIPTION OF THE DRAWINGS

The accompanying drawings are included to provide a further understanding of the invention, and are incorporated in and constitute a part of this specification. The drawings illustrate embodiments of the invention and, together with the description, serve to explain the principles of the invention. In the drawings,

FIG. 1 is a schematic structural diagram of an optical sensor system according to one preferred embodiment of this invention;

FIG. 2a is a cross-sectional side view of the structure along line 2—2' of FIG. 1 according to a first embodiment of this invention;

FIG. 2b is a cross-sectional side view of the structure along line 2—2' of FIG. 1 according to a second embodiment of this invention;

FIG. 3a is a graph showing the variation of light transparency along the long axis of the transparent panel due to the presence of the coating;

FIG. 3b is a graph showing the variation of brightness level along the light axis of the light source; and

FIG. 3c is a graph showing the variation of brightness level after light from the light source passes through the transparent panel.

DESCRIPTION OF THE PREFERRED
EMBODIMENTS

Reference will now be made in detail to the present preferred embodiments of the invention, examples of which are

illustrated in the accompanying drawings. Wherever possible, the same reference numbers are used in the drawings and the description to refer to the same or like parts.

FIG. 1 is a schematic structural diagram of an optical sensor system according to one preferred embodiment of this invention. The system includes, a light source 10, a coating 15, a transparent panel 20 and a sensor 25. The light source 10 is able to generate an image for sensing. The sensor 25, the transparent panel 20 and the coating 15 together constitute the optical sensor. The transparent panel 20 is positioned between the sensor 25 and the light source 10. When the image produced by the light source is projected onto the transparent panel 20, a long axis is created. The coating 15 is formed over one glass surface of the transparent panel 20.

The sensor 25 detects the light image after light from the light source 10 has passed through the coating 15 and the transparent panel 20. The coating 15 on the transparent panel 20 modifies the light transparency along the long axis such that the light transparency is lower in the middle compared with either end.

The coating 15, as shown in FIG. 1, is formed only over the region within the transparent panel 20 where the projected image produced by the light source 10 is covered. In practice, the coating 15 may cover the entire glass surface of the transparent panel 20.

FIG. 2a is a cross-sectional side view of the structure along line 2—2' of FIG. 1 according to a first embodiment of this invention. As shown in FIG. 2a, the coating 15 on the transparent panel 20 is formed using a single material having a variable thickness along the long axis. In other words, the thickness of the coating 15 near the middle is greater than the thickness along the two sides. Light transparency of the coating 15 has a characteristic curve shown in FIG. 3a. In fact, FIG. 3a is a graph showing the variation of light transparency along the long axis of the transparent panel due to the presence of the coating.

FIG. 3b is a graph showing the variation of brightness level along the light axis of the light source. After light from the light source 10 is passed through the transparent panel 20 with a single-layered coating 15, variation of brightness level along the long axis is shown in FIG. 3c. As shown in FIGS. 3b and 3c, brightness level after passing through the transparent panel 20 is much flatter and wider than the brightness level along the light axis of the original light source 10. Since the optical sensor relies heavily on brightness contrast to carry out detection, the brightness curve shown in FIG. 3c is more suitable for image detection than the curve shown in FIG. 3b.

FIG. 2b is a cross-sectional side view of the structure along line 2—2' of FIG. 1 according to a second embodiment of this invention. As shown in FIG. 2b, the coating 15 on the transparent panel 20 is actually comprised of three different coatings 15a, 15b and 15c, each having a different light transparency but identical thickness. All the coatings 15a, 15b and 15c together produce a light transparency curve shown in FIG. 3a. In other words, light transparency in the middle is lower relative to the sides.

FIG. 3b is a graph showing the variation of brightness level along the light axis of the light source. After light from the light source 10 is passed through the transparent panel 20 with multiple coatings 15a, 15b and 15c, variation of brightness level along the long axis is shown in FIG. 3c. As shown in FIGS. 3b and 3c, brightness level after passing through the transparent panel 20 is much flatter and wider than the brightness level along the light axis of the original light

source 10. Since the optical sensor relies heavily on brightness contrast to carry out detection, the brightness curve shown in FIG. 3c is more suitable for image detection than the curve shown in FIG. 3b.

Note that the number of coatings on the transparent panel 20 is not limited to three. To fit a particular design, the number of coatings can increase and the type of material forming the coatings can vary.

In summary, the greatest benefit of this invention is the reduction of brightness variation of a light source without the need to produce new components. In fact, only minor modifications of a single component are needed.

It will be apparent to those skilled in the art that various modifications and variations can be made to the structure of the present invention without departing from the scope or spirit of the invention. In view of the foregoing, it is intended that the present invention cover modifications and variations of this invention provided they fall within the scope of the following claims and their equivalents.

What is claimed is:

1. An installation for increasing [the] a usable range along [the] an axial direction of a light source, comprising:

a light source for generating a sense image; and

an optical sensor, wherein the optical sensor includes a sensor, a transparent panel and a coating, wherein the transparent panel is positioned between the sensor and the light source, the coating is formed over the transparent panel, the transparent panel has a long axis running from edge to edge, the sensor detects an image after light from the light source has passed through the coating and the transparent panel, and the coating on the transparent panel modifies the light transparency along the long axis such that the light transparency is lower in the middle compared with the ends.

2. The installation of claim 1, wherein the coating is formed only over [the] an image-forming region when light passes through the transparent panel.

3. The installation of claim 1, wherein the coating actually comprises [of] a plurality of coatings attached side by side with each coating material having a different light transparency.

4. The installation of claim 1, wherein the sensor includes a charge couple device (CCD).

5. The installation of claim 1, wherein one application is [the] a scanner.

6. An installation for increasing [the] a usable range along [the] an axial direction of a light source, comprising:

a light source for generating a sense image; and

an optical sensor, wherein the optical sensor includes a sensor, a transparent panel and a coating, wherein the transparent panel is positioned between the sensor and the light source, the coating is formed over the transparent panel, the transparent panel has a long axis running from edge to edge, the sensor detects an image after light from the light source has passed through the coating and the transparent panel, and the coating on the transparent panel modifies the light transparency along the long axis such that the light transparency is lower in the middle compared with the ends,

wherein the coating comprises [of] a single coating material but a variable thickness along the long axis.

7. An installation for increasing [the] a usable range along [the] an axial direction of a light source, comprising:

a light source for generating a sense image; and

an optical sensor, wherein the optical sensor includes a sensor, a transparent panel and a coating, wherein the

5

transparent panel is positioned between the sensor and the light source, the coating is formed over the transparent panel, the transparent panel has a long axis running from edge to edge, the sensor detects an image after light from the light source has passed through the coating and the transparent panel, and the coating on the transparent panel modifies the light transparency along the long axis such that the light transparency is lower in the middle compared with the ends,

wherein the coating comprises [of] multiple coating materials with different light transparency but with an equal thickness along the long axis.

8. An apparatus, comprising:

a sensor;

a transparent panel positioned over the sensor; and

a coating formed on a surface of the transparent panel, wherein the coating is configured to provide reduced transparency at a middle portion of the coating relative to an edge portion of the coating.

9. The apparatus of claim 8, wherein the coating comprises a single coating material having a variable thickness.

10. The apparatus of claim 8, wherein the coating comprises a plurality of coating materials.

11. A method, comprising:

forming a coating on a surface of a transparent panel, wherein the coating is configured to provide reduced transparency at a middle portion of the coating relative to an edge portion of the coating; and

positioning the transparent panel between a light source and a sensor.

12. The method of claim 11, wherein forming the coating on the surface of the transparent panel comprises forming a coating having a variable thickness.

13. The method of claim 11, wherein forming the coating on the surface of the transparent panel comprises forming a coating comprising a plurality of coating materials.

14. An apparatus, comprising:

a light source;

a sensor;

a transparent panel positioned between the light source and the sensor; and

a coating formed on a surface of the transparent panel, wherein the coating is configured to provide reduced transparency at a middle portion of the coating relative to an edge portion of the coating.

15. The apparatus of claim 14, wherein the coating comprises a single coating material having a variable thickness.

16. The apparatus of claim 14, wherein the coating comprises a plurality of coating materials.

17. The apparatus of claim 9, wherein the middle portion of the single coating material is thicker than the edge portion.

18. The method of claim 12, wherein the middle portion of the coating is thicker than the edge portion.

19. The apparatus of claim 15, wherein the middle portion of the single coating material is thicker than the edge portion.

20. An apparatus, comprising:

a sensor;

a transparent panel positioned over the sensor; and

a coating formed on a surface of the transparent panel, wherein the coating is configured to provide reduced transparency at a portion of the transparent panel disposed closer to a light source relative to a portion of the transparent panel disposed farther from the light source.

6

21. The apparatus of claim 20, wherein the coating comprises a single coating material having a variable thickness.

22. The apparatus of claim 20, wherein the coating comprises a plurality of coating materials.

23. The apparatus of claim 20, wherein the transparent panel is disposed between the sensor and the light source.

24. A method, comprising:

forming a coating on a surface of a transparent panel, wherein the coating is configured to provide reduced transparency at a portion of the transparent panel disposed closer to a light source relative to a portion of the transparent panel disposed farther from the light source; and

positioning the transparent panel between the light source and a sensor.

25. The method of claim 24, wherein forming the coating on the surface of the transparent panel comprises forming a coating having a variable thickness.

26. The method of claim 24, wherein forming the coating on the surface of the transparent panel comprises forming a coating comprising a plurality of coating materials.

27. An apparatus, comprising:

means for sensing light;

a transparent panel positioned over the light sensing means; and

means for providing reduced transparency at a portion of the transparent panel disposed closer to a light source relative to a portion of the transparent panel disposed farther from the light source.

28. An apparatus, comprising:

means for producing light;

means for sensing light;

a transparent panel positioned between the light producing means and the light sensing means; and

means for providing reduced transparency at a portion of the transparent panel disposed closer to the light producing means relative to a portion of the transparent panel disposed farther from the light producing means.

29. A digital camera, comprising:

a sensor;

a transparent panel positioned over the sensor; and

a coating formed on a surface of the transparent panel, wherein the coating is configured to provide reduced transparency at a portion of the transparent panel disposed closer to a light source relative to a portion of the transparent panel disposed farther from the light source.

30. The digital camera of claim 29, wherein the transparent panel is disposed between the sensor and the light source.

31. A scanner, comprising:

a sensor;

a transparent panel positioned over the sensor; and

a coating formed on a surface of the transparent panel, wherein the coating is configured to provide reduced transparency at a portion of the transparent panel disposed closer to a light source relative to a portion of the transparent panel disposed farther from the light source.

32. The scanner of claim 31, wherein the transparent panel is disposed between the sensor and the light source.

33. A method for increasing the usable range of a light source, the method comprising:

reducing a transparency of a first portion of a transparent panel relative to a transparency of a second portion of

7

the transparent panel, wherein reducing the transparency of the first portion comprises using a coating material having a variable thickness on the transparent panel.

34. The method of claim 33, wherein the first portion is a middle portion of the transparent panel and the second portion is an edge portion of the transparent panel.

8

35. The method of claim 33, wherein the first portion is a portion of the transparent panel disposed closer to the light source relative to the second portion.

36. The method of claim 33, wherein reducing the transparency of the first portion comprises using a plurality of coating materials on the transparent panel.

* * * * *