



US00RE41912E

(19) **United States**  
(12) **Reissued Patent**  
**Parker**

(10) **Patent Number:** **US RE41,912 E**  
(45) **Date of Reissued Patent:** **\*Nov. 2, 2010**

(54) **REUSABLE PULSE OXIMETER PROBE AND DISPOSABLE BANDAGE APPARATUS**

(75) Inventor: **Brent Parker**, Murrieta, CA (US)

(73) Assignee: **Masimo Corporation**, Irvine, CA (US)

(\* ) Notice: This patent is subject to a terminal disclaimer.

(21) Appl. No.: **11/432,798**

(22) Filed: **May 11, 2006**

**Related U.S. Patent Documents**

Reissue of:

(64) Patent No.: **6,735,459**  
Issued: **May 11, 2004**  
Appl. No.: **10/237,038**  
Filed: **Sep. 9, 2002**

U.S. Applications:

(63) Continuation of application No. 09/679,828, filed on Oct. 5, 2000, now Pat. No. 6,519,487, which is a continuation-in-part of application No. 09/417,898, filed on Oct. 14, 1999, now Pat. No. 6,343,224, and a continuation-in-part of application No. 09/289,647, filed on Apr. 12, 1999, now Pat. No. 6,144,868.

(60) Provisional application No. 60/104,332, filed on Oct. 15, 1998.

(51) **Int. Cl.**  
**A61B 5/1455** (2006.01)

(52) **U.S. Cl.** ..... **600/344; 600/310**

(58) **Field of Classification Search** ..... **600/310, 600/322, 323, 340, 344, 473, 476**  
See application file for complete search history.

(56) **References Cited**

**U.S. PATENT DOCUMENTS**

3,463,142 A	8/1969	Harte et al.
3,647,299 A	3/1972	Lavallee
3,740,570 A	6/1973	Kaelin et al.
3,799,672 A	3/1974	Vurek
4,086,915 A	5/1978	Kofsky et al.

4,169,976 A	10/1979	Cirri
4,182,977 A	1/1980	Stricklin, Jr.
4,308,456 A	12/1981	van Der Gaag et al.
4,346,590 A	8/1982	Brown
4,407,290 A	10/1983	Wilber
4,449,821 A	5/1984	Lee
4,480,886 A	11/1984	Bergamin
4,580,867 A	4/1986	Wright et al.
4,621,643 A	11/1986	New, Jr. et al.
4,653,498 A	3/1987	New, Jr. et al.
4,685,464 A	8/1987	Goldberger et al.
4,700,708 A	10/1987	New, Jr. et al.
4,770,179 A	9/1988	New, Jr. et al.
4,830,014 A	5/1989	Goodman et al.
4,848,901 A	7/1989	Hood, Jr.
4,865,038 A	9/1989	Rich et al.
4,877,322 A	10/1989	Hill
4,913,150 A	4/1990	Cheung et al.

(Continued)

**FOREIGN PATENT DOCUMENTS**

AU	745306	5/2000
AU	784021	5/2006
CA	2 346 639	4/2000

(Continued)

**OTHER PUBLICATIONS**

Copending U.S. Appl. No. 11/404,123, filed Apr. 13, 2006, and pending claims.

Copending U.S. Appl. No. 11/774,446, filed Jul. 6, 2007, and pending claims.

Copending U.S. Appl. No. 12/573,851, filed Oct. 5, 2009, and pending claims.

*Primary Examiner*—Eric F Winakur

(74) *Attorney, Agent, or Firm*—Knobbe Martens Olson & Bear, LLP

(57) **ABSTRACT**

Pulse oximeter apparatus and method comprising a reusable pulse oximeter probe and a disposable bandage. The bandage has receptacles for receiving and aligning the oximeter's light emitting diode and photocell detector.

**44 Claims, 12 Drawing Sheets**

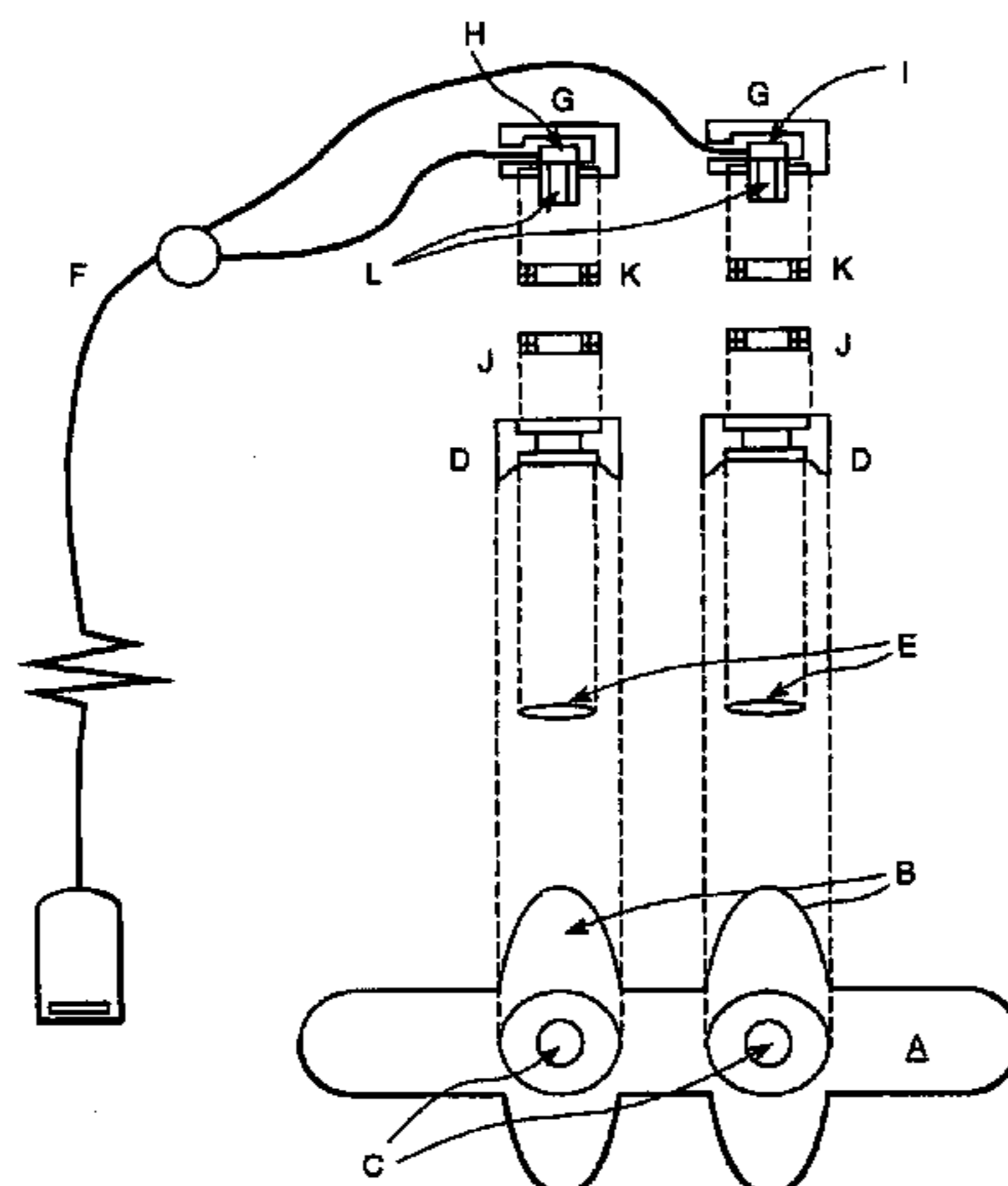

# US RE41,912 E

Page 2

U.S. PATENT DOCUMENTS			RE36,000 E	12/1998	Swedlow et al.
4,942,877	A	7/1990	Sakai et al.	1/1999	Kiani-Azarbayjany et al.
4,960,128	A	10/1990	Gordon et al.	3/1999	Roper et al.
4,964,408	A	10/1990	Hink et al.	4/1999	Mills et al.
5,041,187	A	8/1991	Hink et al.	5/1999	Wohltmann et al.
5,058,588	A	10/1991	Kaestle	6/1999	Solenberger
5,069,213	A	12/1991	Polczynski	7/1999	Taylor et al.
5,090,410	A	2/1992	Saper et al.	7/1999	Diab
5,094,240	A	3/1992	Muz	8/1999	Tobler et al.
5,113,862	A	5/1992	Mortazavi	8/1999	Lepper, Jr. et al.
5,140,228	A	8/1992	Biegel	11/1999	Levin
5,158,323	A	10/1992	Yamamoto et al.	11/1999	Kiani et al.
5,163,438	A	11/1992	Gordon et al.	12/1999	Mills et al.
5,170,786	A	12/1992	Thomas et al.	12/1999	Wang et al.
5,209,230	A	5/1993	Swedlow et al.	12/1999	Diab et al.
5,246,003	A	9/1993	DeLonzor	1/2000	Diab et al.
5,249,576	A	10/1993	Goldberger et al.	1/2000	Raley
5,267,562	A	12/1993	Ukawa et al.	2/2000	Flaherty et al.
5,273,041	A	12/1993	Richards et al.	3/2000	Diab et al.
5,279,295	A	1/1994	Martens et al.	4/2000	Caro et al.
5,287,853	A	2/1994	Vester et al.	5/2000	Lovejoy et al.
5,308,919	A	5/1994	Minnich	5/2000	Diab et al.
5,337,744	A	8/1994	Branigan	6/2000	Diab et al.
5,341,805	A	8/1994	Stavriddi et al.	7/2000	Diab et al.
D353,195	S	12/1994	Savage et al.	8/2000	Lepper, Jr. et al.
D353,196	S	12/1994	Savage et al.	9/2000	Shehada
5,377,676	A	1/1995	Vari et al.	11/2000	Parker
5,387,122	A	2/1995	Goldberger et al.	11/2000	Kiani-Azarbayjany et al.
5,397,247	A	3/1995	Aoki et al.	11/2000	Gerhardt et al.
D359,546	S	6/1995	Savage et al.	12/2000	Diab et al.
5,431,170	A	7/1995	Mathews	12/2000	Mills et al.
D361,840	S	8/1995	Savage et al.	2/2001	Coffin, IV et al.
5,437,275	A	8/1995	Amundsen et al.	3/2001	Diab et al.
D362,063	S	9/1995	Savage et al.	5/2001	Diab et al.
5,452,717	A	9/1995	Branigan et al.	5/2001	Snyder et al.
D363,120	S	10/1995	Savage et al.	5/2001	Diab et al.
5,456,252	A	10/1995	Vari et al.	7/2001	Diab et al.
5,482,036	A	1/1996	Diab et al.	7/2001	Diab et al.
5,490,505	A	2/1996	Diab et al.	8/2001	Lepper, Jr. et al.
5,494,043	A	2/1996	O'Sullivan et al.	8/2001	Tobler et al.
5,507,286	A	4/1996	Solenberger	9/2001	Tobler et al.
5,515,169	A	5/1996	Cargill et al.	10/2001	von der Ruhr et al.
5,533,511	A	7/1996	Kaspari et al.	11/2001	King
5,561,275	A	10/1996	Savage et al.	11/2001	Parker
5,590,649	A	1/1997	Caro et al.	12/2001	Al-Ali et al.
5,602,924	A	2/1997	Durand et al.	1/2002	Parker
5,619,992	A	4/1997	Guthrie et al.	2/2002	Kiani et al.
5,632,272	A	5/1997	Diab et al.	3/2002	Diab et al.
5,638,816	A	6/1997	Kiani-Azarbayjany et al.	4/2002	Xu et al.
5,638,818	A	6/1997	Diab et al.	4/2002	Caro et al.
5,645,440	A	7/1997	Tobler et al.	4/2002	Al-Ali
5,660,567	A	8/1997	Nierlich et al.	4/2002	Ashibe
5,664,270	A	9/1997	Bell et al.	5/2002	Schulz et al.
5,673,693	A	10/1997	Solenberger	5/2002	Diab et al.
5,678,544	A	10/1997	DeLonzor et al.	8/2002	Weber et al.
5,685,299	A	11/1997	Diab et al.	10/2002	Diab
D393,830	S	4/1998	Tobler et al.	10/2002	Kopotic et al.
5,743,262	A	4/1998	Lepper, Jr. et al.	12/2002	Diab et al.
5,758,644	A	6/1998	Diab et al.	1/2003	Kollias et al.
5,760,910	A	6/1998	Lepper, Jr. et al.	2/2003	Al-Ali
5,769,785	A	6/1998	Diab et al.	2/2003	Parker
5,782,757	A	7/1998	Diab et al.	2/2003	Mills et al.
5,785,659	A	7/1998	Caro et al.	2/2003	Kiani et al.
5,786,592	A	7/1998	Hök	4/2003	Schulz et al.
5,791,347	A	8/1998	Flaherty et al.	4/2003	Al-Ali et al.
5,810,734	A	9/1998	Caro et al.	6/2003	Schulz et al.
5,817,008	A	10/1998	Rafert et al.	6/2003	Ali et al.
5,817,010	A	10/1998	Hibl	7/2003	Cybulski et al.
5,823,950	A	10/1998	Diab et al.	7/2003	Tian et al.
5,830,131	A	11/1998	Caro et al.	7/2003	Kiani et al.
5,833,618	A	11/1998	Caro et al.	8/2003	Ali et al.





# US RE41,912 E

Page 4

---

WO	WO 88/10462	12/1998
WO	WO 99/53831	10/1999
WO	WO 00/21433	4/2000
WO	WO 00/42911	7/2000

WO	WO 01/03574	1/2001
----	-------------	--------

\* cited by examiner

FIG. 1

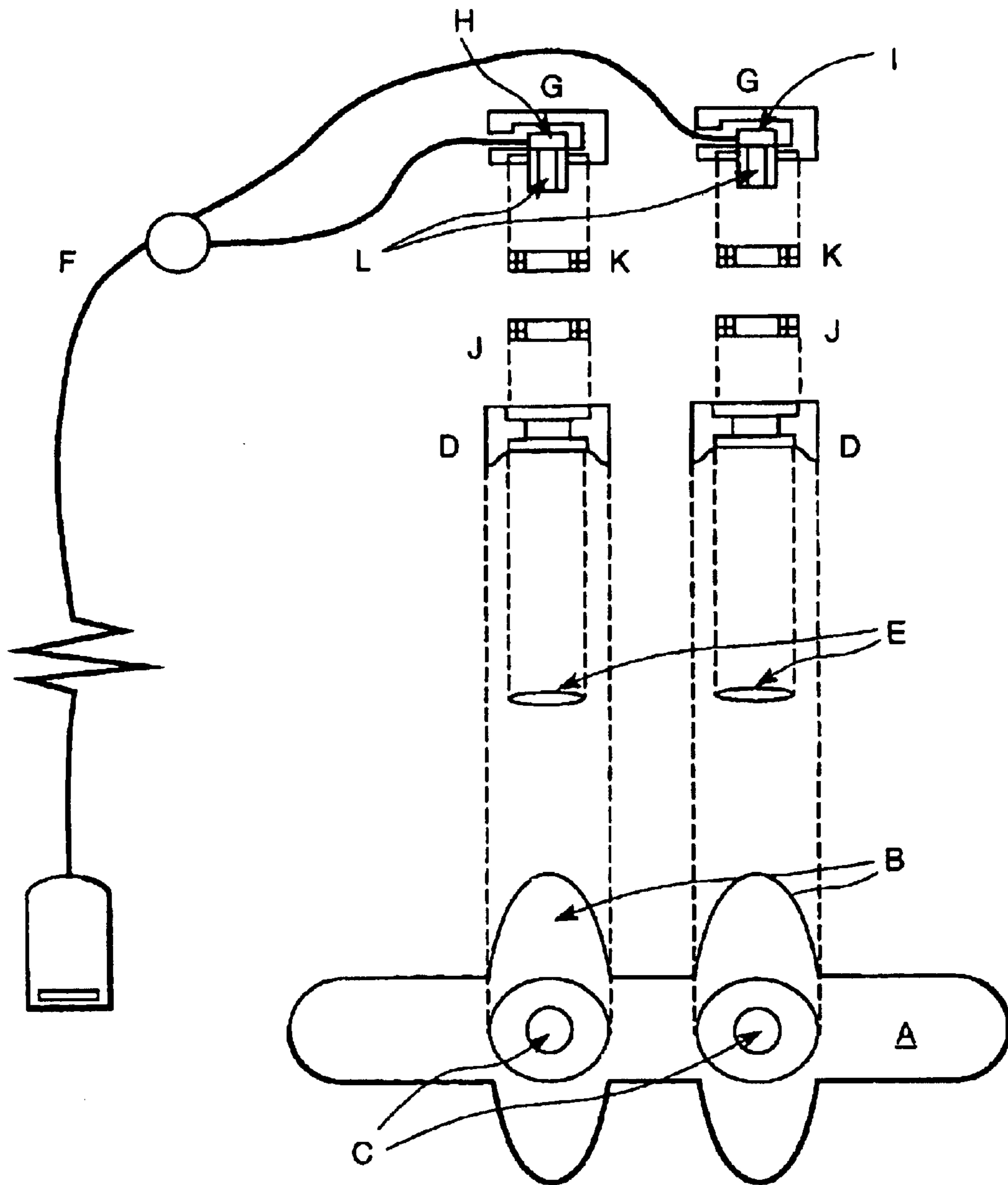

FIG. 2

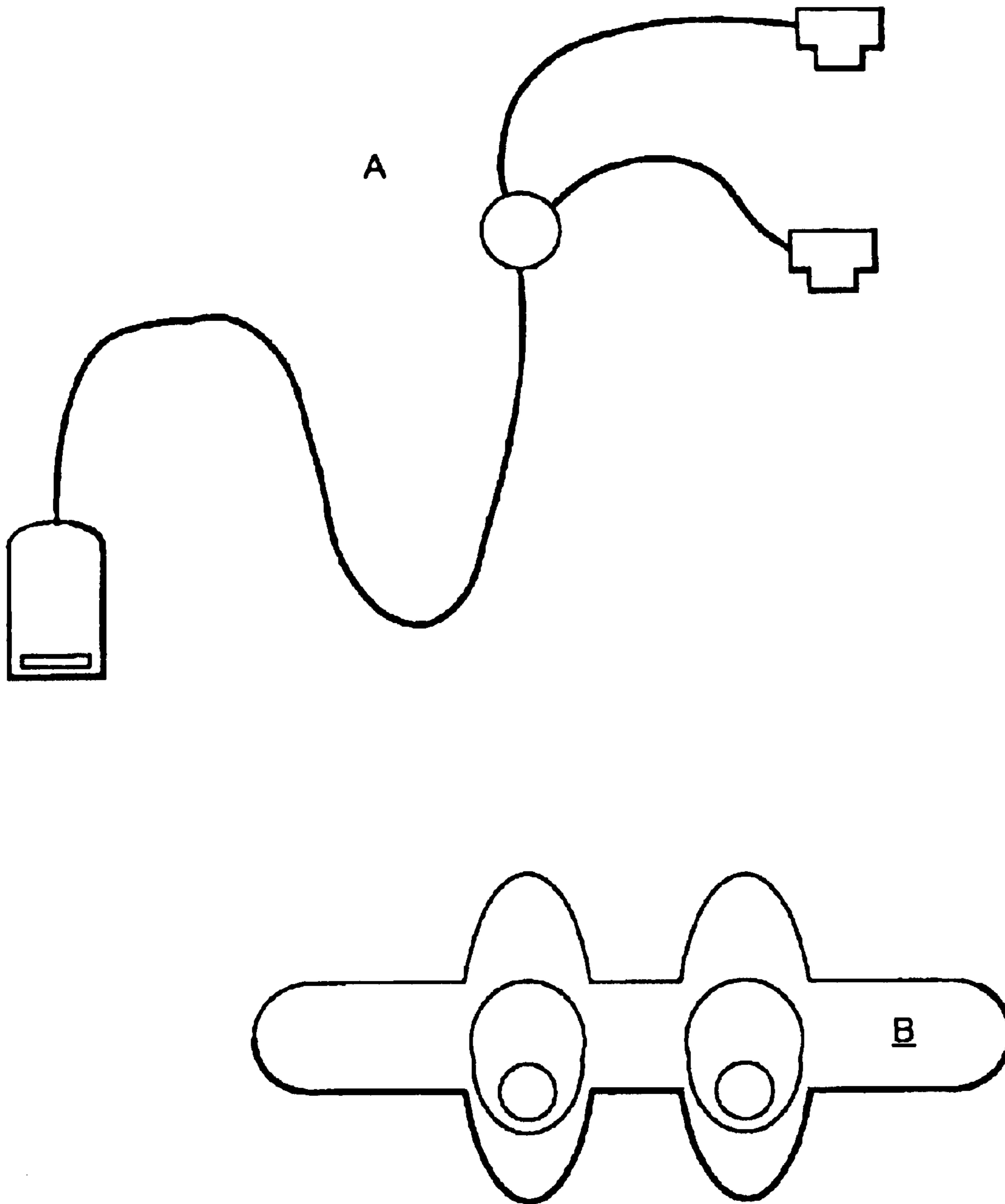

FIG. 3

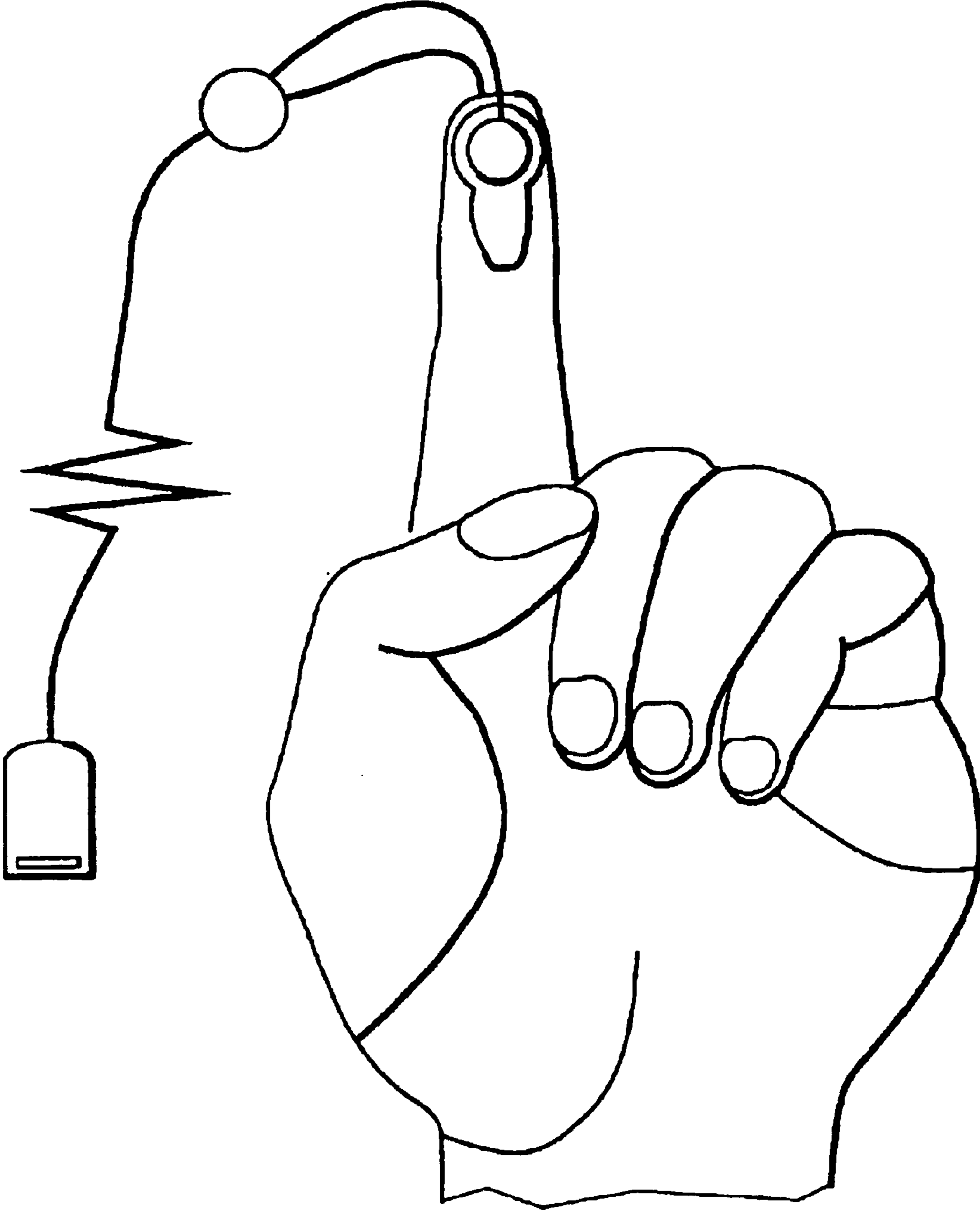
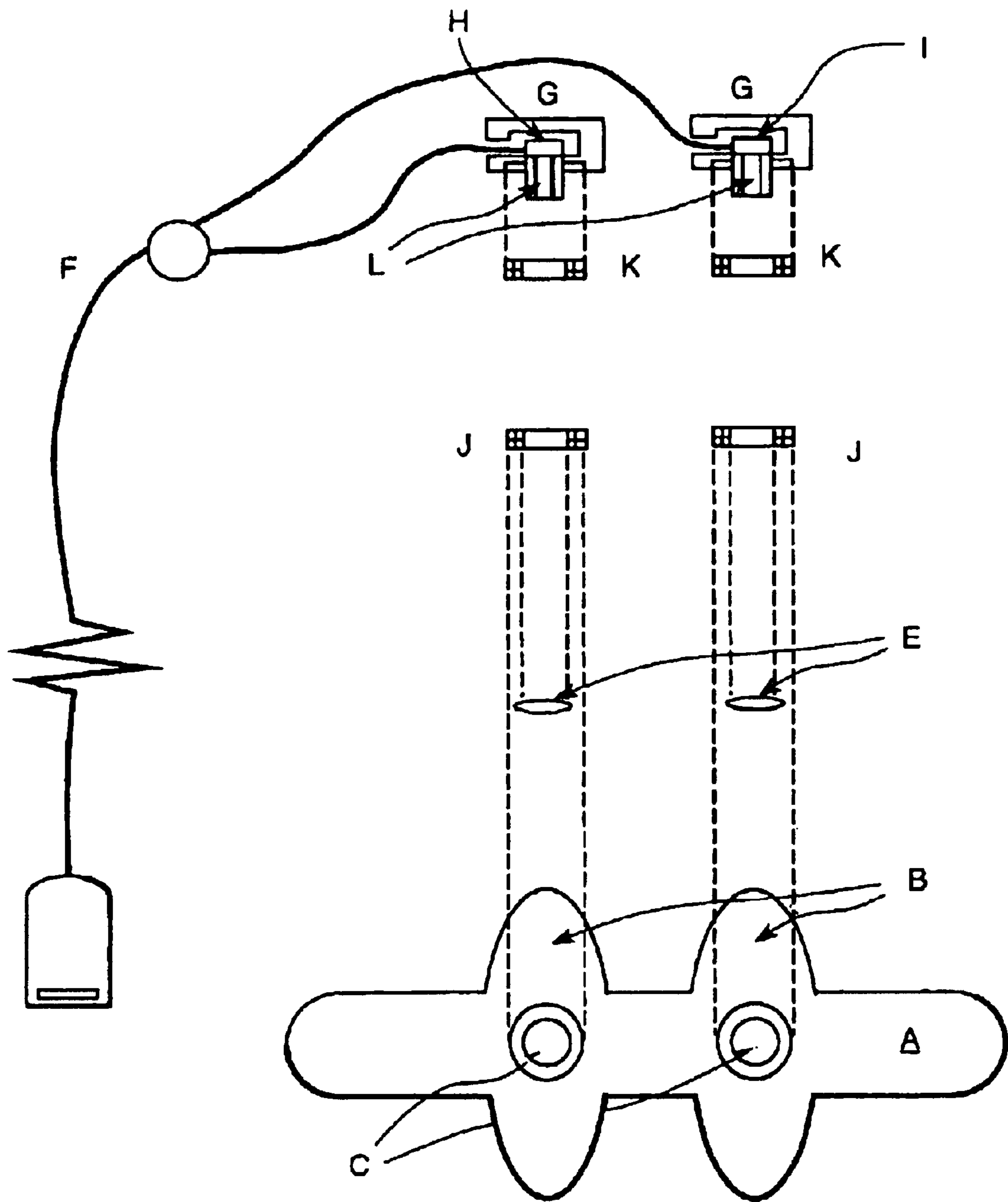

FIG. 4





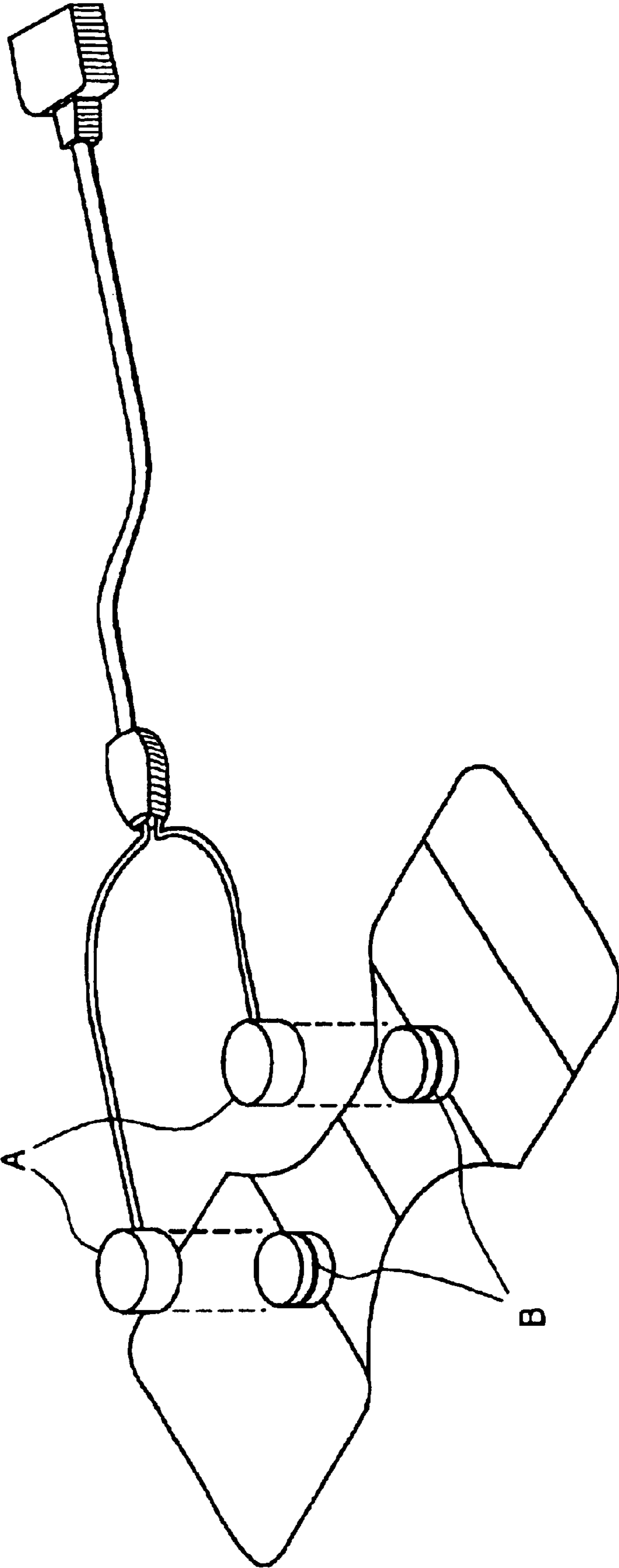

FIG. 5

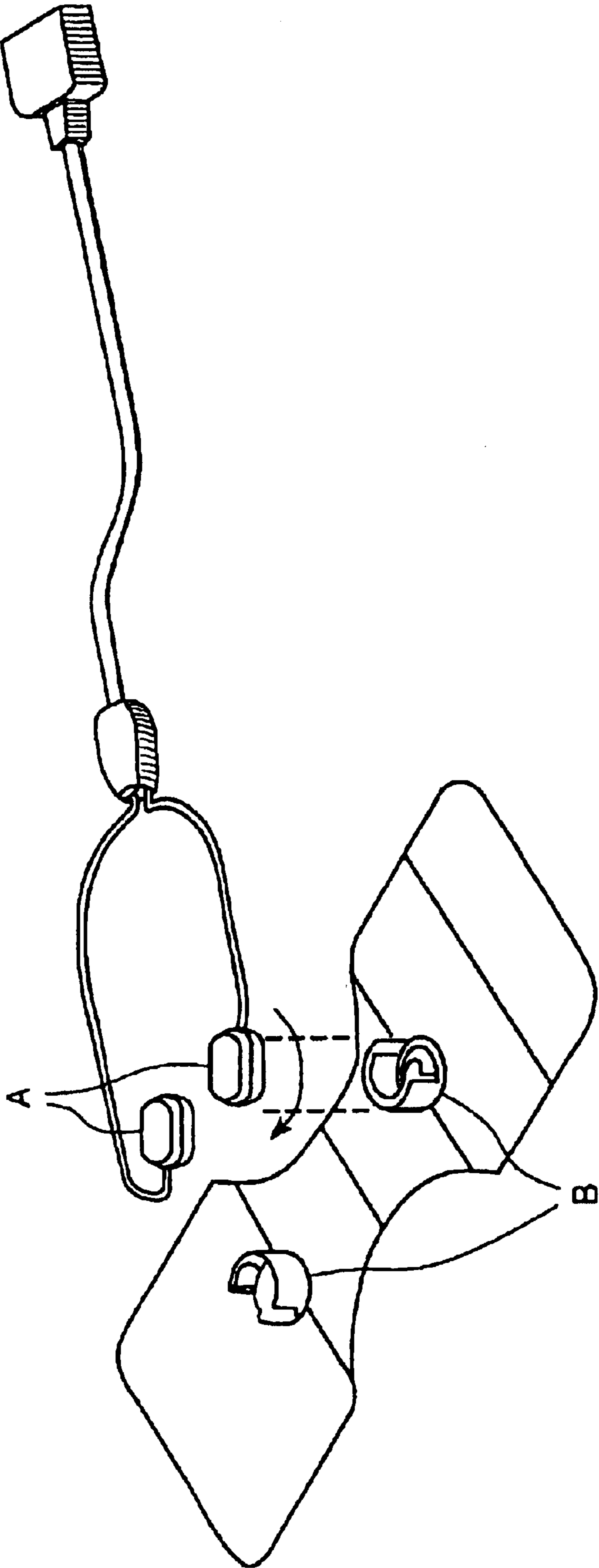

FIG. 6

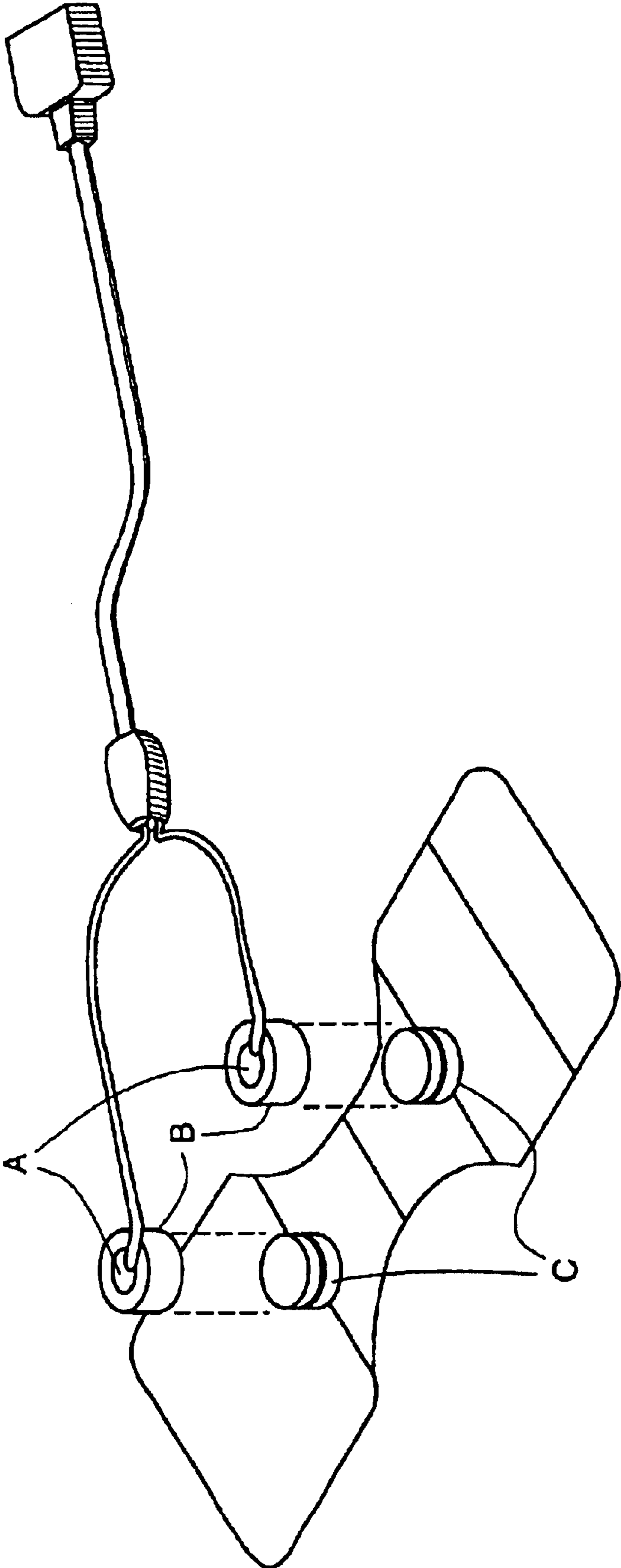

FIG. 7

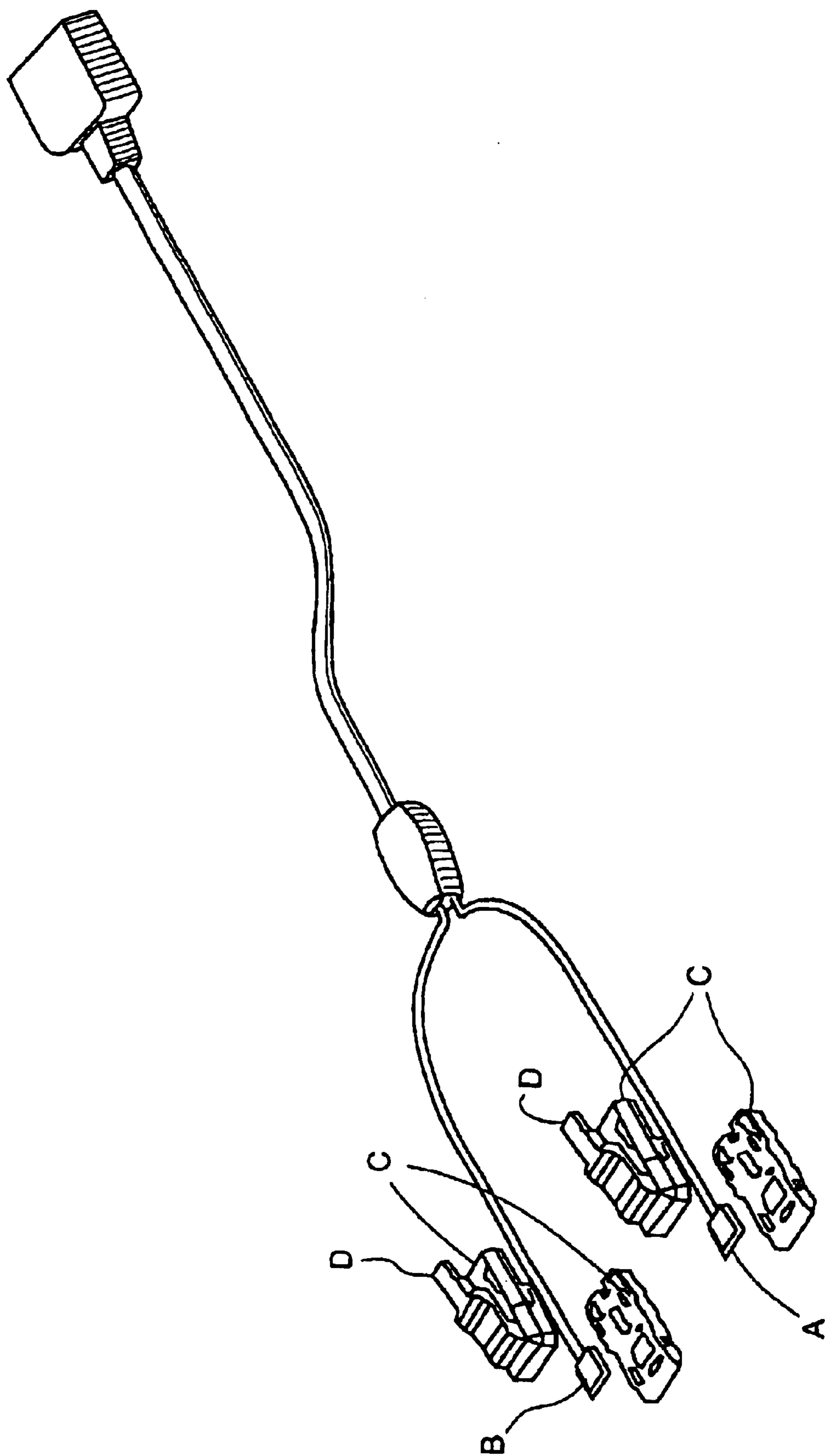
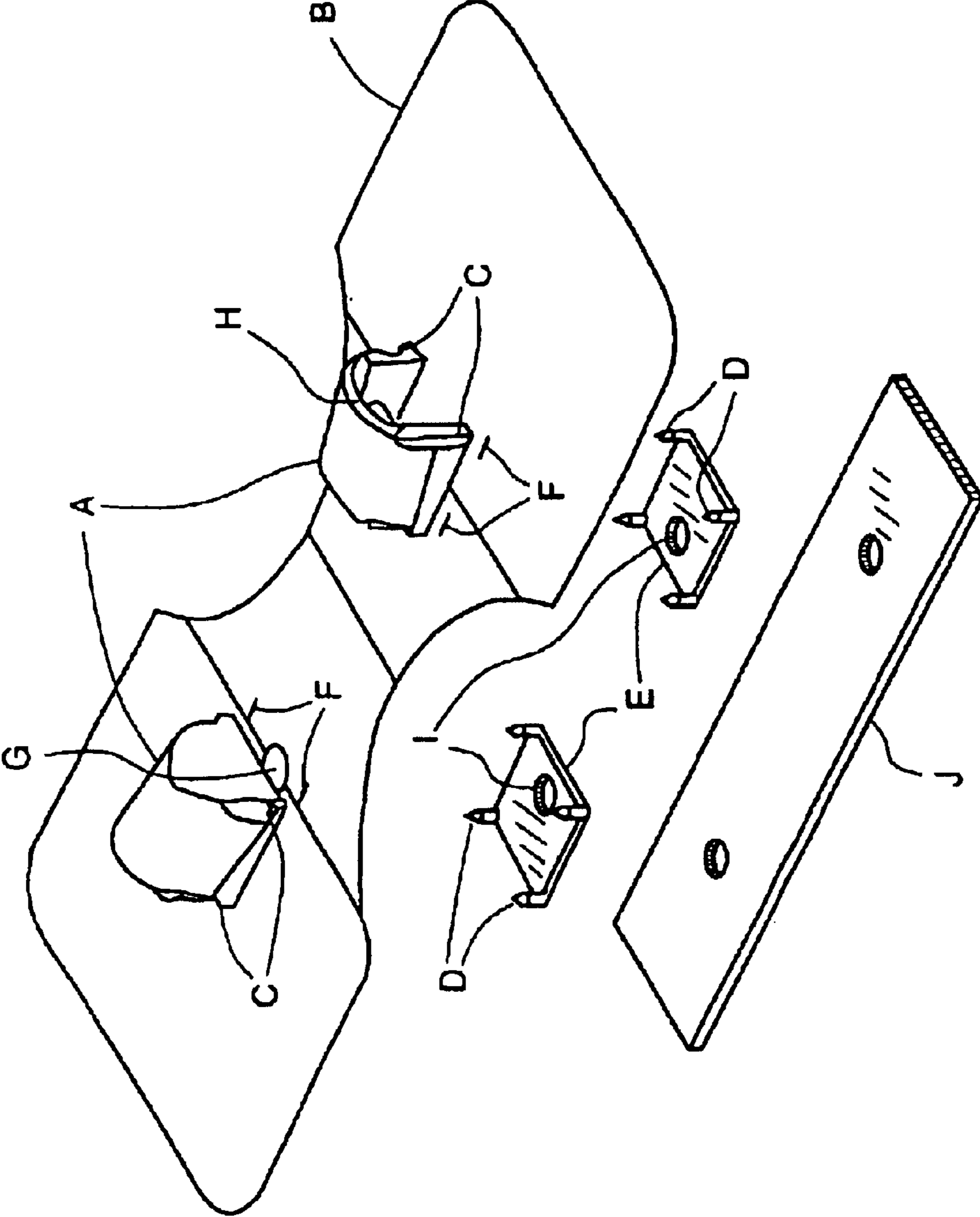

FIG. 8



FIG. 9



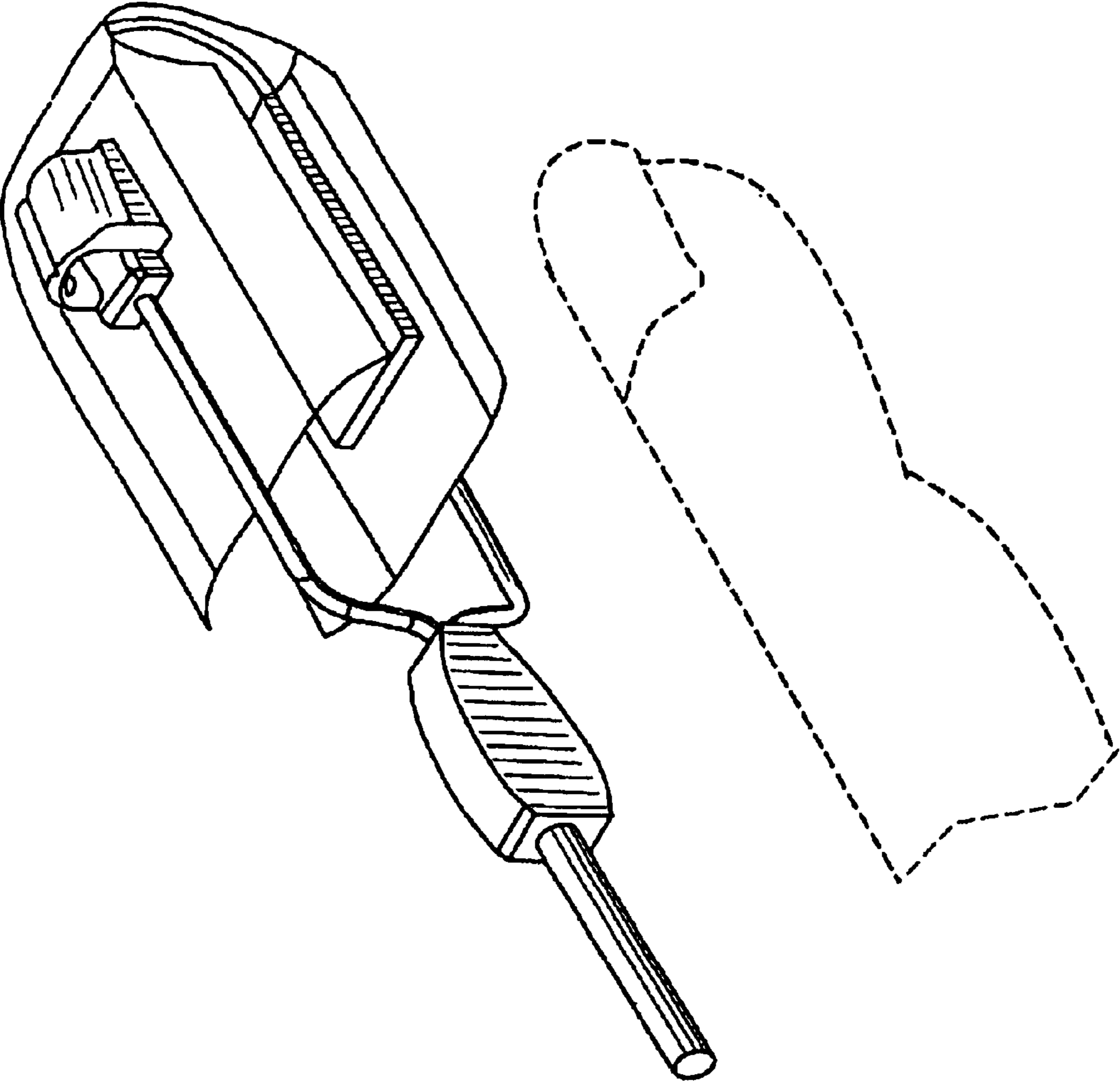
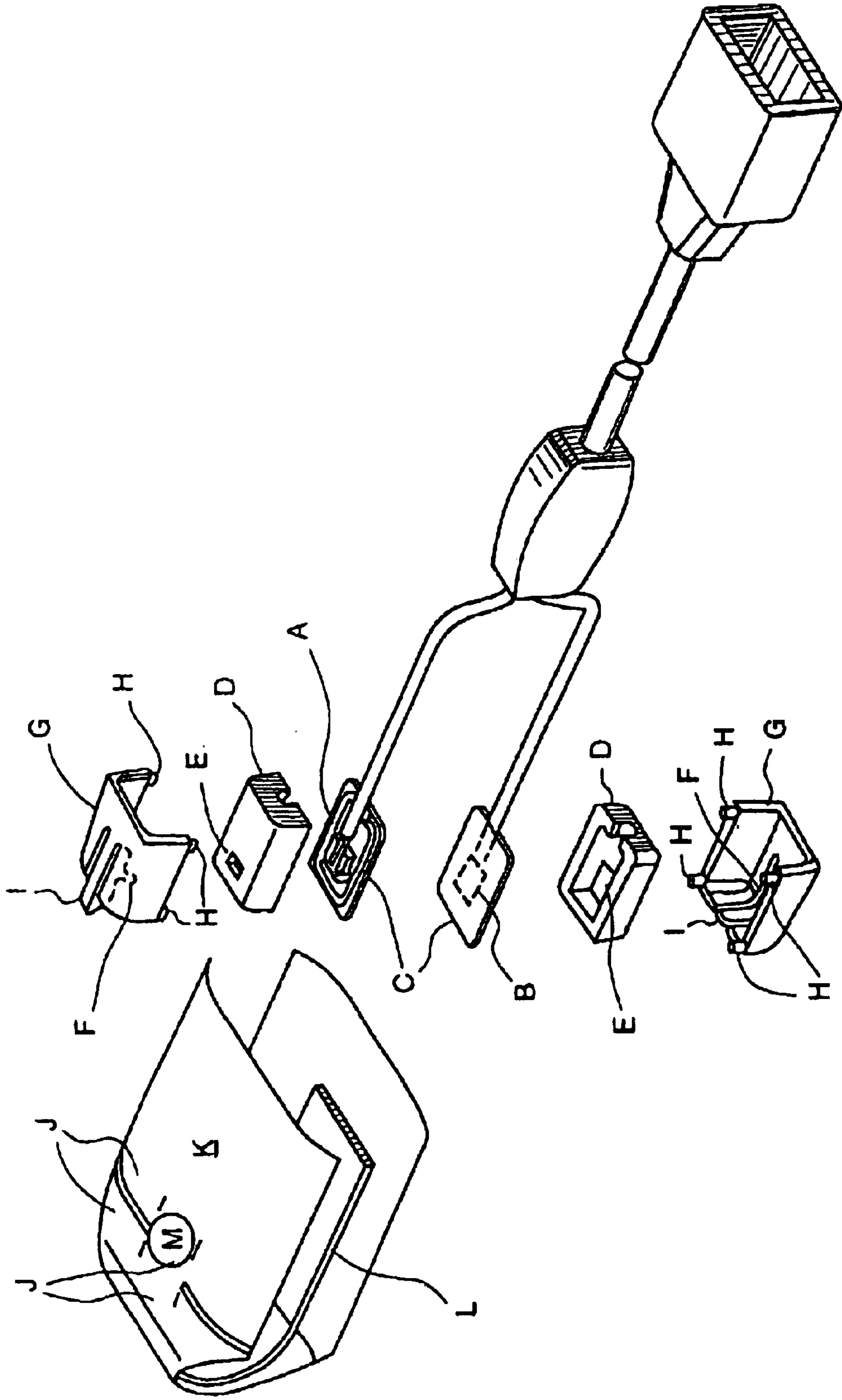

FIG. 10

FIG. 11



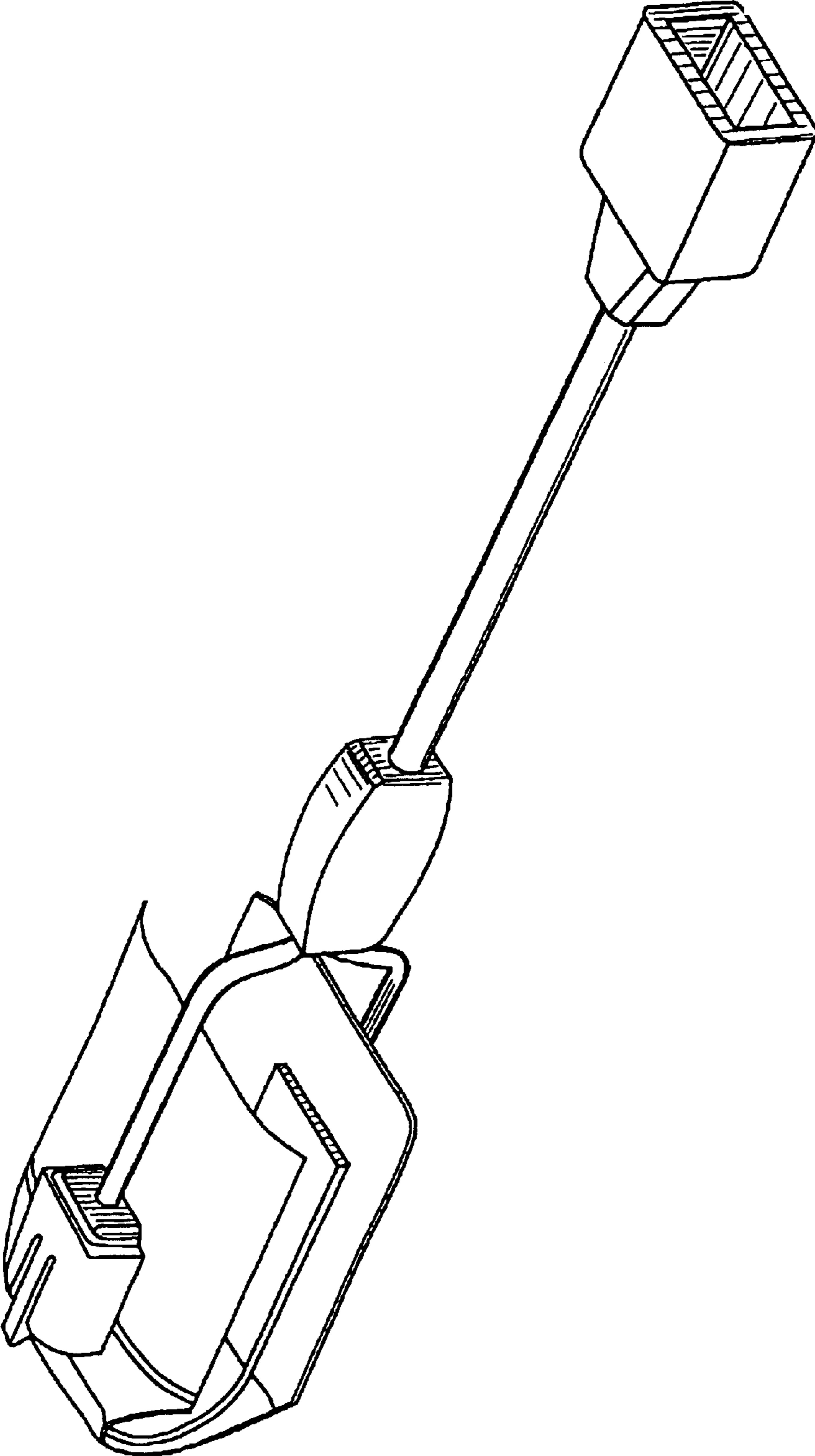

FIG. 12



## REUSABLE PULSE OXIMETER PROBE AND DISPOSABLE BANDAGE APPARATUS

**Matter enclosed in heavy brackets [ ] appears in the original patent but forms no part of this reissue specification; matter printed in italics indicates the additions made by reissue.**

### [Reference to Related Application] *REFERENCE TO RELATED APPLICATIONS*

This is a continuation application of application U.S. Ser. No. 09/679,828 filed Oct. 5, 2000 (now U.S. Pat. No. 6,519,487), which in turn is a continuation-in-part of U.S. Ser. Nos. *09/417,898 filed Oct. 14, 1999 (now U.S. Pat. No. 6,343,224)* and 09/289,647 filed Apr. 12, 1999 (now U.S. Pat. No. 6,144,868) [and 09/417,898 filed Oct. 14, 1999 (now U.S. Pat. No. 6,343,224)]; which in turn claims benefit of provisional application No. 60/104,332 filed Oct. 15, 1998.

### BACKGROUND OF THE INVENTION

The present invention relates to a method of making and affixing a reusable probe to a patient by means of disposable bandage apparatus so that there is no contact between the costly, reusable portion of the probe and the patient. The contaminated bandage apparatus, which is relatively inexpensive, can then be discarded after single patient use and the probe can be re-used with a new bandage apparatus.

Heretofore the use of pulse oximeter probes has been limited to the use of a costly reusable probe, which is contaminated by use on a patient, or cheaper, single-use probes, which, in the aggregate, amount to a considerable expenditure for a health care institution.

Other individuals have attempted to convert single use probes into multi-use probes through a lamination process. In that process, the original adhesive material is removed from the original manufacturer's sensor. The sensor is then laminated in a plastic sheath and the entire sheath is then inserted into a transparent, adhesive-backed sleeve, which is then adhered to a patient. After use, the probe can then be extracted from the sleeve and inserted into a new sleeve for use on another patient.

There are certain disadvantages to this method. Firstly, it is difficult to insert the flexible laminated sensor into a long sleeve. Secondly, the thickness of a laminated sensor inside of a sleeve makes it difficult to bend around, and to stick properly to, a human appendage. Thirdly, transmission and reception of infrared light can be affected by extraneous light entering from the sides of the sleeve. And fourthly, there is some dispute as to the affect on infrared light transmission when passing through the sleeve and the adhesive material coupled thereto.

### THE PRESENT INVENTION

The present invention not only solves the problems outlined above, but offers an alternative that is cheap to manufacture and easy to use.

The present invention is directed to improving the form and affixation method of a reusable pulse oximeter sensor. It comprises a reusable pulse oximeter probe with at least one light emitting diode and one photocell detector wherein said emitter and detector are enclosed in plastic housings, one housing having an aperture or radiation transparent window aligned with said emitter, and the other housing having an aperture or radiation transparent window aligned with said

detector. Also included is a disposable bandage apparatus which is at least one bandage strip having adhesive on at least a portion of at least one face thereof and at least two plastic receptacles mounted thereon, each receptacle having at least one aperture or radiation transparent window located therein. The probe housings can matedly engage said bandage receptacles and transmit and receive light through the apertures or radiation transparent windows of said mated housings and receptacles, and through the appendage of a patient. The housings of the reusable pulse oximeter probe may also be made of a material selected from plastic, rubber, metal, wood, or other composite material. The receptacles of the disposable bandage apparatus may also be made of a material selected from plastic, rubber, metal, wood, or other composite material. Additionally, the apertures of said receptacles are large enough to accept the tubular protrusions of the housings for the purpose of concentric location and alignment of the housings to the receptacles and the proper transmission and reception of light therethrough. Sandwiched between the adhesive strip and the receptacles attached thereto, are translucent silicone windows or windows of another radiation transparent material for isolation of the reusable probe assembly from the patient. The bandage apparatus may be discarded after single patient use and the reusable probe may be used again on another patient in conjunction with another bandage apparatus. Additionally, the receptacles of the bandage apparatus may have a concave surface on one side thereof in order to seat conformably on a human digit, or they may have a flat surface on at least one side thereof in order to attach conformably to a human foot, nose, or ear. The housings and receptacles also contain "mushroom hook" type hook and loop material for the purpose of adhering and detaching said housings to and from said receptacles. Additionally, the housings and receptacles have recessed areas for adhesion of the "mushroom hook" hook and loop material.

In another embodiment of the invention, the receptacle of the disposable bandage apparatus may be the mushroom hook material itself which may be attached directly to the adhesive strip for the selective engagement of the housings of the probe assembly.

In another embodiment of the invention, the housings of the pulse oximeter probe may be affixed to the receptacles of the disposable bandage apparatus by means of a "ring and groove" type snap-on connector.

In yet another embodiment of the invention, the housings of the reusable pulse oximeter probe may be affixed to the receptacles of the disposable bandage apparatus by means of a "twist and lock" type connector.

In a further embodiment of the invention, the housings of the pulse oximeter probe may be affixed to the receptacles of the disposable bandage apparatus by means of a "threaded flange" type of connector.

Finally, and in the first preferred embodiment of the invention, The light emitting diode and photocell detector of the probe assembly may be mounted in modular housings with locking levers which can engage an indentation or slot in the receptacles of the disposable bandage apparatus and securely lock the housings into proper position within the receptacles, thus allowing the transmission and reception of infrared light through the mated housings and receptacles and through the appendage of a patient.

In another variation of this preferred embodiment of the invention, the levers and indentations are reversed, and the light emitting diode and photocell detector of the probe assembly may be mounted in modular housings having



3

indentations therein, and the receptacles of the disposable bandage apparatus may have the locking lever located on them. In such an embodiment, the locking levers of the bandage receptacles lockingly engage the slots or indentations in the probe housings, thus locking them into place within the receptacles and allowing the transmission and reception of infrared light through the mated probe housings and bandage receptacles, and through the appendage of a patient.

In these modular housing and receptacle embodiments the radiation transparent windows, may be of hard plastic and may be mounted against the skin of a patient, thus being used to secure the receptacles on the opposite side of the bandage strip. This is accomplished by the incorporation of locking levers on the radiation transparent windows which are pushed through holes or slots in the bandage and engage holes in the receptacles mounted on the opposite side of the bandage, thus sandwiching the bandage in between. A foam strip with holes in it may also be adhered to said radiation transparent windows in order for them to rest comfortably on a patient's appendage.

In another variation of the above, the bandage receptacles may be secured to the bandage through the use of small plastic protrusions or "heat stakes" mounted on the receptacles themselves. These protrusions can be pushed through slots in the bandage and can be melted on the other side of the bandage strip by means of an ultrasonic welding machine, thus locking the receptacles into position on the bandage strip. In this embodiment a radiation transparent window may then be adhered to the underside of the bandage strip and the heat stakes and radiation transparent windows may then be overlaid with a foam pad with holes in it, the purpose of which is to allow for the transmission and reception of infrared light through the holes while aiding in patient comfort.

#### DESCRIPTION OF THE DRAWINGS

The above and other objects and features of the invention will become more clear when considered with the following specifications and accompanying drawings wherein:

FIG. 1 is an exploded view of the reusable pulse oximeter probe and disposable bandage apparatus incorporating the invention;

FIG. 2 is a view of the reusable pulse oximeter probe and disposable bandage apparatus shown individually as components of the invention;

FIG. 3 illustrates the invention in use on a human finger or digit;

FIG. 4 illustrates an exploded view of another embodiment of the invention in which the "mushroom hook" material itself is used as the receptacle of the disposable bandage apparatus;

FIG. 5 illustrates an assembled view of another embodiment of the invention in which the housings of the pulse oximeter probe are affixed to the receptacles of the disposable bandage apparatus by means of ring and groove type, snap-on connectors;

FIG. 6 illustrates an assembled view of another embodiment of the invention in which the housings of the pulse oximeter probe are affixed to the receptacles of the disposable bandage apparatus by means of "twist and lock" type connectors;

FIG. 7 illustrates an assembled view of another embodiment of the invention in which the housings of the pulse oximeter probe are affixed to the receptacles of the disposable bandage apparatus by means of a "threaded flange" type of connector;

4

FIG. 8 illustrates an exploded view of the first preferred embodiment of the reusable pulse oximeter probe in which the light emitting diode and photocell detector of the probe are encased in housings having a radiation transparent window therein and locking levers for affixing the reusable pulse oximeter probe to the disposable bandage apparatus;

FIG. 9 illustrates an exploded view of the first preferred embodiment of the disposable bandage apparatus in which the receptacle tops incorporate a slot for engaging the locking levers of the modular probe housings, and wherein the radiation transparent windows are mounted on the opposite side of the bandage strip thus sandwiching and securing the bandage in between the two receptacle halves by means of locking tabs or heat stakes that can be ultrasonically welded;

FIG. 10 illustrates the first preferred embodiment of the invention as it would appear ready for use on a human digit;

FIG. 11 illustrates an exploded view of the second preferred embodiment of the invention in which the probe housings have a slot or indentation incorporated therein and the bandage receptacles have a locking lever for securing the housings to the receptacles;

FIG. 12 illustrates an assembled view of the second preferred embodiment of the invention in which the probe housings have a slot or indentation incorporated therein and the bandage receptacles have a locking lever for securing the housings to the receptacles.

#### DESCRIPTION OF THE REUSABLE PULSE OXIMETER SENSOR

The Reusable Pulse Oximeter Sensor constitutes a "Y" style pulse oximeter probe shown as FIG. 1, Item F. Said probe incorporates two plastic housings shown as FIG. 1, Items G, said housings containing apertures or radiation transparent windows therein, said apertures or windows shown as FIG. 1, Items L. One housing contains the light emitting diode of the probe, FIG. 1, item H, and the other contains the photocell detector, FIG. 1, Item I. The emitter and detectors are aligned with the apertures or windows of said housings in order to transmit and receive light through a human appendage. Seated within a recessed area of each housing, and attached permanently thereto, is a "mushroom hook" adhesive-backed pad, FIG. 1, Item K. The purpose of these pads is to selectively engage the "mushroom hook" pads, FIG. 1, Items J, attached permanently to the plastic discs, FIG. 1, Items D, and to attach the reusable probe assembly to the Disposable Bandage Apparatus. The Reusable Pulse Oximeter Sensor is shown assembled as FIG. 2, Item A.

In another embodiment of the invention the light emitting diode and photocell detector of the reusable pulse oximeter sensor are enclosed in housings (FIG. 5, Items A) having a groove on the inner diameter of the housings that is designed to matedly engage rings (FIG. 5, Items B) located on the outer diameter of the disposable bandage apparatus, thus securing and locking the sensor housings to the bandage receptacles.

In another embodiment of the invention the light emitting diode and photocell detector of the reusable pulse oximeter sensor are enclosed in housings (FIG. 6, Items A) which are designed to enter the bandage receptacles (FIG. 6, Items B) and to twist 90 degrees thus locking the sensor housings to the bandage receptacles.

In yet another embodiment of the invention, the light emitting diode and photocell detector of the reusable pulse oximeter sensor are enclosed in housings (FIG. 7, Items A) having a threaded flange (FIG. 7, Items B) that threadedly



5

engages the bandage receptacles, (FIG. 7, Items C) thus securing and locking the sensor housings to the bandage receptacles.

In the first preferred embodiment of the Reusable Pulse Oximeter Sensor, the light emitting diode (FIG. 8, Item A) and photocell detector (FIG. 8, Item B) of the probe assembly are housed in modular receptacles (FIG. 8, Items C) having locking levers, (FIG. 8, Items D) for engaging the receptacles (FIG. 9, Items A) of the disposable bandage apparatus, and locking them into place.

In the second preferred embodiment of the Reusable Pulse Oximeter Sensor, the light emitting diode (FIG. 11, Item A) and the photocell detector (FIG. 11, Item B) are encased in modular housings having a radiation transparent bottom (FIG. 11, Items C) and having opaque housing tops (FIG. 11, Items D). These housing tops and bottoms are ultrasonically welded together thus encapsulating the light emitting diode and photocell detector of the probe assembly. The housing tops incorporate indentations or slots (FIG. 11, Items E) designed to matedly engage a protrusion on the locking levers of the bandage receptacles thus snapping into place and securing the probe housings within the bandage receptacles.

#### DESCRIPTION OF THE DISPOSABLE BANDAGE APPARATUS

The components of the apparatus include an adhesive-backed, strip, shown as FIG. 1, item A, said strip incorporating two oval protrusions centered thereon and shown as FIG. 1, Item B. Said strip also incorporates two apertures, centrally located within said oval protrusions, FIG. 1, Item C, each aperture having a diameter sufficient in size to accommodate the transmission and reception of light from a light emitting diode and photocell detector of a pulse oximeter probe.

On top of said apertures are seated two plastic discs, FIG. 1, Item D, each having a concave base designed to conform to the radius of a human digit, and an aperture of slightly larger diameter than the apertures in the adhesive backed planar strip. Said plastic discs are affixed to the adhesive planar strip by means of a permanent adhesive. Seated in a recessed area on top of each plastic disc is a "mushroom hook", adhesive backed pad shown as FIG. 1, Item J. The purpose of the "mushroom hook" pads is to selectively engage the "mushroom hook" pads attached to the probe, FIG. 1, Items K, and to attach the probe to the disposable bandage apparatus. Sandwiched between the two plastic discs and the planar adhesive strip are two translucent silicone windows, FIG. 1, Item E. Said windows are designed to permit the passage of infrared light and yet prevent contact between probe and patient, and consequently, contamination of the reusable probe itself.

The above items constitute the Disposable Bandage Apparatus of the invention, said apparatus being shown assembled as FIG. 2, Item B.

In another embodiment of the invention, the Disposable Bandage Apparatus may be configured as in FIG. 4 of the drawings. In that drawing there is an exploded view of the apparatus in which the "mushroom hook" pads of the bandage apparatus, FIG. 4, Items J, are bonded directly to the adhesive planar strip, FIG. 4, Item A, for the selective engagement of the "mushroom hook" pads of the probe, FIG. 4, Items K, said pads being attached permanently to the housings of the probe, FIG. 4, Items G.

In other embodiments of the disposable bandage apparatus, the bandage may have mounted thereon recep-

6

tacles having means of matedly engaging the housings of the reusable pulse oximeter sensor by way of "ring and groove" snap-on type connectors (FIG. 5, Items B); "Twist and Lock" type connectors (FIG. 6, Items B); or "threaded flange" type connectors (FIG. 7, Items C).

In the first preferred embodiment of the Disposable Bandage Apparatus, the bandage strip (FIG. 9, Item B) is sandwiched between interlocking receptacle halves. The top halves of the receptacles (FIG. 9, Items A) each contain 4 holes (FIG. 9, Items C) that are designed to matingly engage locking tabs (FIG. 9, Items D) on the bottom half of the receptacles (FIG. 9, Items E) that are pushed through slots cut in the bandage strip (FIG. 9, Items F) thus securing and locking the bandage in between.

The bandage strip contains two apertures or radiation transparent windows (FIG. 9, Items G) allowing for the transmission and reception of light from the light emitting diode and photocell detector of the pulse oximeter sensor which are encased in modular housings having locking levers (FIG. 8, Items D) wherein said levers engage slots in the receptacles (FIG. 9, Items H) thereby locking the housings into place within the receptacles. In addition, the bottom halves of the receptacles (FIG. 9, Items E) can be of a radiation transparent material, or may contain apertures (FIG. 9, Items I) thus allowing the light emitting diode and photocell detector contained in the probe housings, when engaged in the bandage receptacles, to transmit and receive light through the apertures of the bandage strip and through the radiation transparent material, or apertures, of the bottom halves of the receptacles, and through the appendage of a patient. The disposable bandage apparatus may also incorporate a foam strip (FIG. 9, Item J) in order to cushion a patient's appendage from any discomfort caused by the bottom half of the bandage receptacles. The complete Reusable Pulse Oximeter Sensor, engaged in the disposable Bandage Apparatus, and ready for use on a human appendage, is shown in FIG. 10.

In the second preferred embodiment of the disposable bandage apparatus, the bandage receptacles (FIG. 11, Items G) are secured to the bandage (FIG. 11, Item K) by means of four protrusions or "heat Stakes" (FIG. 11, Items H) which are pushed through slots (FIG. 11, Items J) on the bandage (FIG. 11, Item K) and are ultrasonically welded on the other side, thus securing the receptacles to the bandage. A radiation transparent window (FIG. 11, Item M) is then adhered to the underside of the bandage and the radiation transparent windows and melted heat stakes are then overlaid by a foam pad (FIG. 11, Item L) to aid in patient comfort. This foam pad also incorporates two holes which are in alignment with the two holes on the bandage itself, and when the foam pad is overlaid on the underside of the bandage, the radiation transparent windows are sandwiched in between.

The probe housings are designed to matedly engage the bandage receptacles (FIG. 11, Items G) and are held in place: within the receptacles by means of protrusions (FIG. 11, Items F) on the locking levers (FIG. 11, Items I) which snap into place when the probe housings are pushed into the bandage receptacles. When the probe housings are locked into place within the bandage receptacles the light emitting diode and photocell detector are in alignment with the holes in the bandage and the foam overlay, and the probe is then able to transmit and receive light through the mated housings and receptacles, through the holes contained in the bandage and foam overlay, and through the appendage of a patient. The complete assembled Reusable Pulse Oximeter Sensor engaged within the Disposable Bandage Apparatus, as it would appear ready for use on a patient, is shown in FIG. 12.



## Other Fastening Means

As can be appreciated there are many ways of fabricating the above components of the invention. The above description describes attachment of the Reusable Pulse Oximeter Sensor to the Disposable Bandage Apparatus by way of a “mushroom hook” type hook and loop material, by the use of “ring and groove” type snap-on connectors, “push and twist” type Luerlock connectors, and threaded flange type connectors’ as well as telephone type, modular connectors and receptacles. While these means are fairly comprehensive, they should in no way be considered exhaustive.

## Method of Use

For use on each individual patient, the probe is affixed in the following manner:

Firstly, the backing is removed from the adhesive strip of the Disposable Bandage Apparatus. One of the apertures of the apparatus is visually positioned on the center of the nail bed of the patient’s appendage and one side of the adhesive strip and the oval protrusions are adhered to the patient’s digit. The rest of the strip is then looped over the end of the patient’s appendage, and the plastic disc is aligned so as to exactly oppose the plastic disc already attached to the other side of the digit. Once the Disposable Bandage Apparatus has been properly adhered to the patient, the plastic housings of the probe assembly can be easily snapped into place on opposing sides of the digit. The entire assembled probe is shown as it would appear in use on a patient in FIG. 3.

For use with the “ring and groove” type snap-on connectors, “twist and lock”, and “threaded flange” connectors, the backing is firstly removed from the adhesive strip. The strip is then folded in half where indicated on the bandage and the bandage apparatus is adhered to either side of the human digit. Once the bandage apparatus is in place the probe housings are simply snapped, twisted or screwed into place.

For use with each patient, the modular probe and bandage assembly, in both of its embodiments, which are the preferred embodiments of the invention, would be attached as follows:

Firstly, the backing is removed from the adhesive strip. The strip is then folded where indicated on the bandage and the strip is then adhered to opposing sides of the human digit. Once the bandage apparatus is in place, the housings of the probe are pushed into the receptacles and locked in place by means of the locking levers.

In all embodiments of the invention, when the probe is no longer required on the patient, the housings of the Reusable Probe are simply unsnapped from the Disposable Bandage Apparatus, the bandage apparatus is thrown away, and the probe can then be reused on a new patient in conjunction with a new bandage apparatus.

## ADVANTAGES OF THE PRESENT INVENTION

Current reusable pulse oximeter probes are either “Clam Shell” type clamping devices which can restrict circulation or “Y” type probes which are taped directly to the patient. Both types also come in direct contact with the patient’s skin and bodily fluids and need sterilization after use. Because of the fact that these devices incorporate many surfaces and at times, porous materials, proper sterilization is very difficult. With the present invention there is no contact between the reusable probe and the skin or bodily fluids of the patient.

Disposable probes are very costly because of the fact that the cable, connectors and photodiodes are all disposed of after use. The present invention accomplishes the same goals as a disposable probe from a cleanliness standpoint, but

since only the attachment apparatus is discarded after use, the cost is much less to a healthcare institution.

The present invention, with the concave shape of the plastic discs of the bandage apparatus, when backed by the adhesive strip, is extremely effective in preventing the entrance of extraneous light from the sides of the patient’s digit. Current probes on the market, whether disposable or reusable, because of the nature of their shape and affixation means, have problems in dealing with extraneous light reception.

The present invention utilizes an easy snap on, snap off, or modular connector attachment means for attaching the probe to the Disposable Bandage Apparatus. Probe-Shield type devices available in the past not only required the modification of the original manufacturer’s probe, but required the difficult procedure of inserting a flexible laminated probe into a sheath for each patient.

Probe-Shield devices, because of the lamination process involved, raised some concern over the transmission and reception of infrared light through the laminating material. The present invention uses a silicone window for the isolation of the probe from the patient. Infrared light transmission and reception is not affected by passage through translucent silicone.

In these days of environmental consciousness the annual waste generated from tens of millions of disposable probes is enormous. The present invention, if used in considerable numbers, would greatly reduce the amount of environmental waste generated by disposable pulse oximeter probes.

While the invention has been described in relation to preferred embodiments of the invention, it will be appreciated that other embodiments, adaptations and modifications of the invention will be apparent to those skilled in the art.

What is claimed is:

1. [In a reusable] A pulse oximeter system, comprising a reusable probe [having a light-emitting diode and a photocell detector, the improvement] having a light emitter and a light detector, said probe comprising a pair of modular housings [and wherein the light emitting diode and the photocell detector], said light emitter and light detector of said probe [are] being mounted on, or incorporated into, one of said modular housings, respectively, each housing [having means for matedly engaging] being configured to matedly engage at least one bandage receptacle, [and being] wherein said housings are configured to be retained, at least in part, thereon or therein, by [means of] a locking tab or lever, and the pulse oximeter system comprising a bandage apparatus having adhesive on at least a portion of at least one face thereof, wherein the bandage apparatus comprises a pair of receptacles operably attached thereto and configured to matedly engage said modular housings.

2. The pulse oximeter [probe] system of claim 1 wherein at least one of said housings has mounted thereon, or incorporates therein, said locking tab or lever.

3. The pulse oximeter [probe] system of claim 1 wherein at least one of said housings incorporates therein, a slot or indentation, said slot or indentation for the purpose of retaining therein said locking tab or lever, said locking lever being located on or in said bandage receptacle or receptacles.

4. A disposable bandage apparatus comprising [at least one face, adhesive on at least a portion of said at least one face thereof, and] at least two receptacles mounted on said disposable bandage apparatus, each receptacle [having means for matedly engaging] being configured to matedly engage at least one housing of a pulse oximeter probe, [and] wherein a locking mechanism [retaining] retains at least a portion of said probe housing thereon or therein, and said



*disposable bandage apparatus comprising adhesive on at least a portion of at least one face thereof.*

5. An adhesive bandage apparatus], said adhesive bandage apparatus] comprising at least two receptacles mounted thereon, said at least two receptacles each having at least one aperture or radiation transparent window therein; at least a first of said receptacles being adapted to matedly engage, and lock into place, the housing of a pulse oximeter probe, said probe housing containing, or having mounted thereon, at least one light emitting diode; and a second of said receptacles being adapted to matedly engage, and lock into place, the housing of a pulse oximeter probe, said probe housing containing, or having mounted thereon, at least one photocell detector; wherein when so mated, said probe housings and bandage receptacles allow for the transmission and reception of light through the apertures or radiation transparent windows of said mated housings and receptacles, and through the appendage of a patient.

6. An oximeter probe attachment system comprising, a first adhesive bandage apparatus having at least one receptacle mounted thereon, said at least one receptacle having at least one radiation transparent window therein; said at least one receptacle being adapted to matedly engage, and lock into place, the housing of a pulse oximeter probe component, said housing containing, or having selectively mounted thereon, at least one light emitting diode, or having mounted thereon, at least one photocell detector; and at least one second adhesive bandage apparatus having at least one receptacle mounted thereon, said at least one bandage receptacle being adapted to matedly engage, and lock into place, the housing of a pulse oximeter probe component, said probe housing containing, or having mounted thereon, at least one light emitting diode, or said probe housing containing, or having mounted thereon, at least one photocell detector; wherein said at least two adhesive bandage apparatus can be positioned upon a patient to allow for the transmission and reception of light through the radiation transparent windows of said mated housings and receptacles, and through the appendage of said patient.

7. *The pulse oximeter system of claim 1, wherein said light emitter comprises a light emitting diode.*

8. *The pulse oximeter system of claim 1, wherein said light detector comprises a photocell detector.*

9. *The disposable bandage apparatus of claim 4, wherein the locking mechanism comprises one or more of a fastener, a hook and loop material, a snap-on connector, a ring, a groove, a notch, a twistable connector, a contoured portion, a threaded connector, a flange, a lever, a tab, an indentation, and a slot.*

10. *A method of providing a sensor capable of sensing a physiological parameter of a patient, the method comprising:*

*providing a sensor having first and second modular housings comprising a light emitter and a light detector, respectively;*

*providing a bandage having adhesive on at least a portion of at least one face thereof, the bandage having first and second receptacles operably attached thereto and configured to matedly engage said first and second modular housings; and*

*releasably securing said first and second modular housings to said first and second receptacles by one or more engagement mechanisms.*

11. *The method of claim 10, wherein said providing the sensor comprises providing at least one of said first and second modular housings including a locking element.*

12. *The method of claim 10, wherein said providing the bandage comprises providing at least one of the first and second receptacles including a locking element.*

13. *A bandage apparatus configured to receive a sensor for sensing a physiological parameter of a patient, the bandage apparatus comprising first and second receptacles operably attached thereto and configured to matedly engage first and second modular housings of the sensor, said receptacles being releasably securable to the modular housings by one or more engagement mechanisms, and the bandage apparatus comprising adhesive on at least a portion of at least one face thereof.*

14. *The bandage apparatus of claim 13, wherein at least one of said first and second receptacles comprises at least one of the one or more engagement mechanisms comprising a locking element.*

15. *The bandage apparatus of claim 13, wherein at least one of the first and second receptacles comprises at least one of the one or more engagement mechanisms comprising a fastener.*

16. *The bandage apparatus of claim 13, wherein the one or more engagement mechanisms comprise a hook-and-loop type material.*

17. *The bandage apparatus of claim 13, wherein the one or more engagement mechanisms comprise a snap-on connector.*

18. *The bandage apparatus of claim 13, wherein the one or more engagement mechanisms comprise a ring.*

19. *The bandage apparatus of claim 13, wherein the one or more engagement mechanisms comprise a groove.*

20. *The bandage apparatus of claim 13, wherein the one or more engagement mechanisms comprise a notch.*

21. *The bandage apparatus of claim 13, wherein the one or more engagement mechanisms comprise a twistable connector.*

22. *The bandage apparatus of claim 13, wherein the one or more engagement mechanisms comprise a contoured portion of a receptacle.*

23. *The bandage apparatus of claim 13, wherein the one or more engagement mechanisms comprise a threaded connector.*

24. *The bandage apparatus of claim 13, wherein the one or more engagement mechanisms comprise a flange.*

25. *The bandage apparatus of claim 13, wherein the one or more engagement mechanisms comprise a lever.*

26. *The bandage apparatus of claim 13, wherein the one or more engagement mechanisms comprise a tab.*

27. *The bandage apparatus of claim 13, wherein the one or more engagement mechanisms comprise an indentation.*

28. *The bandage apparatus of claim 13, wherein the one or more engagement mechanisms comprise a slot.*

29. *A probe system for sensing a physiological parameter of a patient comprising a disposable adhesive bandage apparatus having first and second receptacles mounted thereon and being adapted to matedly engage, and lock into place, first and second housings of a probe component, the first housing comprising a light emitter and the second housing comprising a light detector, wherein said disposable adhesive bandage apparatus can be positioned upon a patient to allow for the transmission and reception of a signal through an appendage of the patient.*

30. *The probe system of claim 29, wherein at least one of the first and second receptacles comprises an engagement mechanism including a hook-and-loop type material.*

31. *The probe system of claim 29, wherein at least one of the first and second receptacles comprises an engagement mechanism including a snap-on connector.*

32. *The probe system of claim 29, wherein at least one of the first and second receptacles comprises an engagement mechanism including a ring.*



## 11

33. The probe system of claim 29, wherein at least one of the first and second receptacles comprises an engagement mechanism including a groove.

34. The probe system of claim 29, wherein at least one of the first and second receptacles comprises an engagement 5 mechanism including a notch.

35. The probe system of claim 29, wherein at least one of the first and second receptacles comprises an engagement mechanism including a twistable connector.

36. The probe system of claim 29, wherein at least one of the first and second receptacles comprises an engagement 10 mechanism including a contoured portion of the receptacle.

37. The probe system of claim 29, wherein at least one of the first and second receptacles comprises an engagement mechanism including a threaded connector.

38. The probe system of claim 29, wherein at least one of the first and second receptacles comprises an engagement 15 mechanism including a flange.

39. The probe system of claim 29, wherein at least one of the first and second receptacles comprises an engagement 20 mechanism including a lever.

40. The probe system of claim 29, wherein at least one of the first and second receptacles comprises an engagement mechanism including a tab.

41. The probe system of claim 29, wherein at least one of the first and second receptacles comprises an engagement 25 mechanism including an indentation.

42. The probe system of claim 29, wherein at least one of the first and second receptacles comprises an engagement mechanism including a slot.

## 12

43. A method of sensing a physiological parameter of a patient comprising:

providing an adhesive bandage apparatus comprising at least two receptacles mounted thereon, said at least two receptacles each having at least one aperture or radiation transparent window therein;

matedly engaging, and locking into place, at least a first of said receptacles with a first housing of a pulse oximeter probe, said first housing containing, or having mounted thereon, at least one light emitting diode;

matedly engaging, and locking into place, at least a second of said receptacles with a second housing of a pulse oximeter probe, said second housing containing, or having mounted thereon, at least one photocell detector;

transmitting and receiving light through the apertures or radiation transparent windows of said first and second housings and receptacles, and through the appendage of a patient.

44. The method of claim 43, additionally comprising:  
disengaging at least the first of said receptacles from the first housing of the pulse oximeter probe; and  
disengaging at least the second of said receptacles from the second housing of the pulse oximeter probe.

\* \* \* \* \*

UNITED STATES PATENT AND TRADEMARK OFFICE  
**CERTIFICATE OF CORRECTION**

PATENT NO. : RE41,912 E  
APPLICATION NO. : 11/432798  
DATED : November 2, 2010  
INVENTOR(S) : Brent Parker

Page 1 of 1

It is certified that error appears in the above-identified patent and that said Letters Patent is hereby corrected as shown below:

Column 1, line 20, above the heading, "BACKGROUND OF THE INVENTION", insert: --Notice:  
More than one reissue application has been filed for the reissue of patent 6,735,459. The reissue  
applications are: 12/917,433, filed November 1, 2010, is a continuation of 11/432,798, filed May 11,  
2006, now RE41,912, a reissue of 10/237,038, filed September 9, 2002, now Patent No. 6,735,459.--

Signed and Sealed this  
Thirty-first Day of July, 2012

A handwritten signature in black ink that reads "David J. Kappos". The signature is written in a cursive, slightly slanted style.

David J. Kappos  
*Director of the United States Patent and Trademark Office*