



US00RE41834E

(19) **United States**
(12) **Reissued Patent**
Parks

(10) **Patent Number:** **US RE41,834 E**
(45) **Date of Reissued Patent:** **Oct. 19, 2010**

(54) **LENS ASSEMBLY PARTS AND ASSEMBLIES THEREFROM**

(75) Inventor: **Gerald R. Parks**, Chula Vista, CA (US)

(73) Assignee: **Dye Precision, Inc.**, San Diego, CA (US)

(21) Appl. No.: **11/863,161**

(22) Filed: **Sep. 27, 2007**

Related U.S. Patent Documents

Reissue of:

(64) Patent No.: **6,948,813**
Issued: **Sep. 27, 2005**
Appl. No.: **10/349,274**
Filed: **Jan. 21, 2003**

(51) **Int. Cl.**
G02C 1/00 (2006.01)

(52) **U.S. Cl.** **351/158; 351/62; 351/154; 2/436**

(58) **Field of Classification Search** **351/41, 351/44, 62, 83-86, 140, 141, 149, 154, 158; 2/9, 12, 15, 426-437, 442, 443, 452, 453**

See application file for complete search history.

(56) **References Cited**

U.S. PATENT DOCUMENTS

4,101,983	A	*	7/1978	Dera et al.	
4,768,231	A	*	9/1988	Schrack	2/13
D317,063	S	*	5/1991	Johnson	
D344,160	S	*	2/1994	Boza	
5,617,588	A	*	4/1997	Canavan et al.	
5,682,621	A	*	11/1997	Park	2/441
5,867,841	A	*	2/1999	Chiang	2/436
6,149,268	A	*	11/2000	Hall et al.	351/62
6,332,682	B1	*	12/2001	Yoshida	351/153
6,363,528	B1	*	4/2002	Cyr	
6,370,695	B2	*	4/2002	Paris et al.	
6,381,749	B1	*	5/2002	Cyr	
2003/0140403	A1	*	7/2003	Chou	2/428
2004/0060101	A1	*	4/2004	Shiue	2/426

* cited by examiner

Primary Examiner—Huy K Mai

(74) *Attorney, Agent, or Firm*—Knobbe Martens Olson & Bear LLP

(57) **ABSTRACT**

A set of lens assembly parts which contains a base and a frame and at least one or more of a lens, fasteners for securing the lens between the base and the frame, a mask, and a strap. Lens assemblies formed from the set of lens assembly parts.

37 Claims, 16 Drawing Sheets

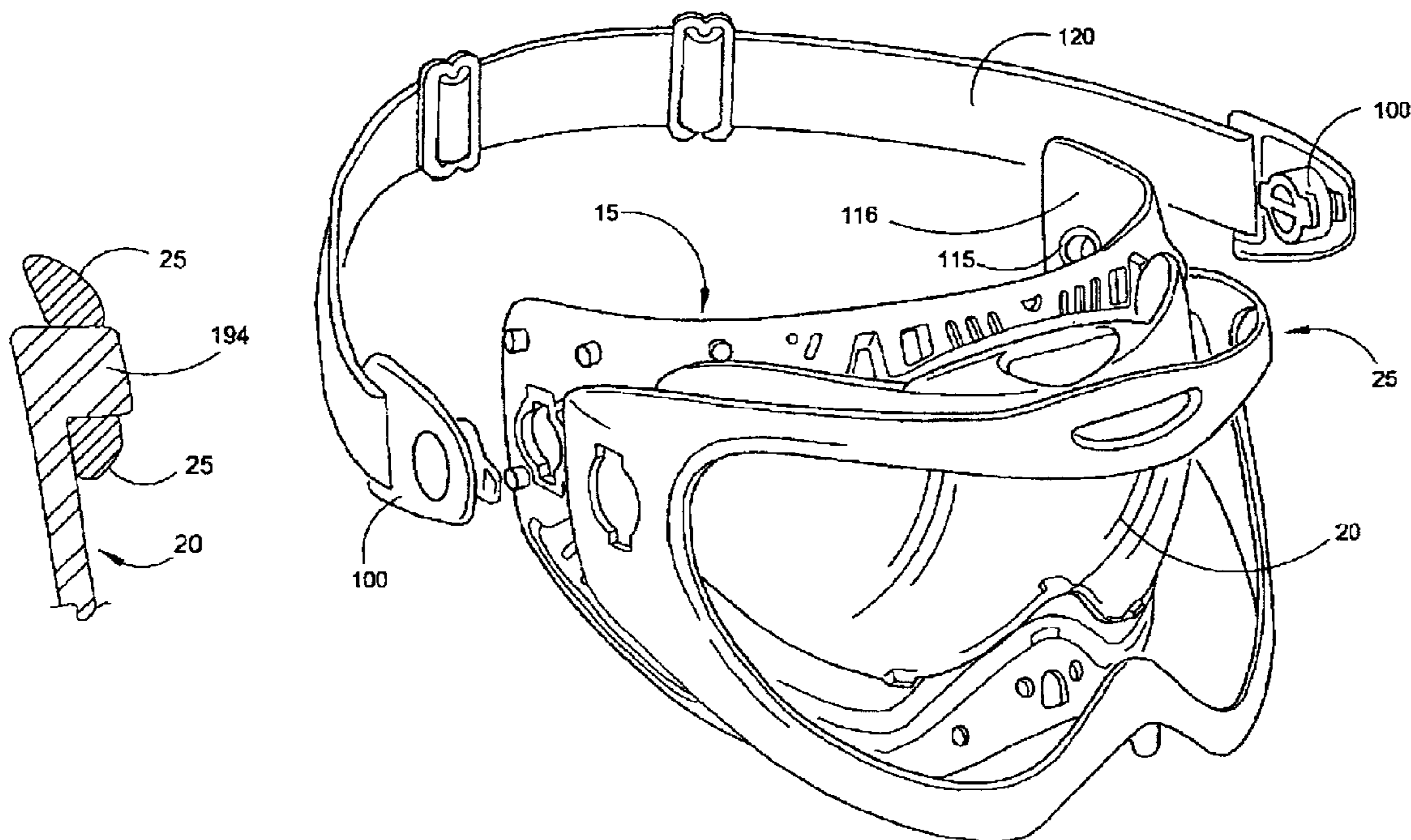

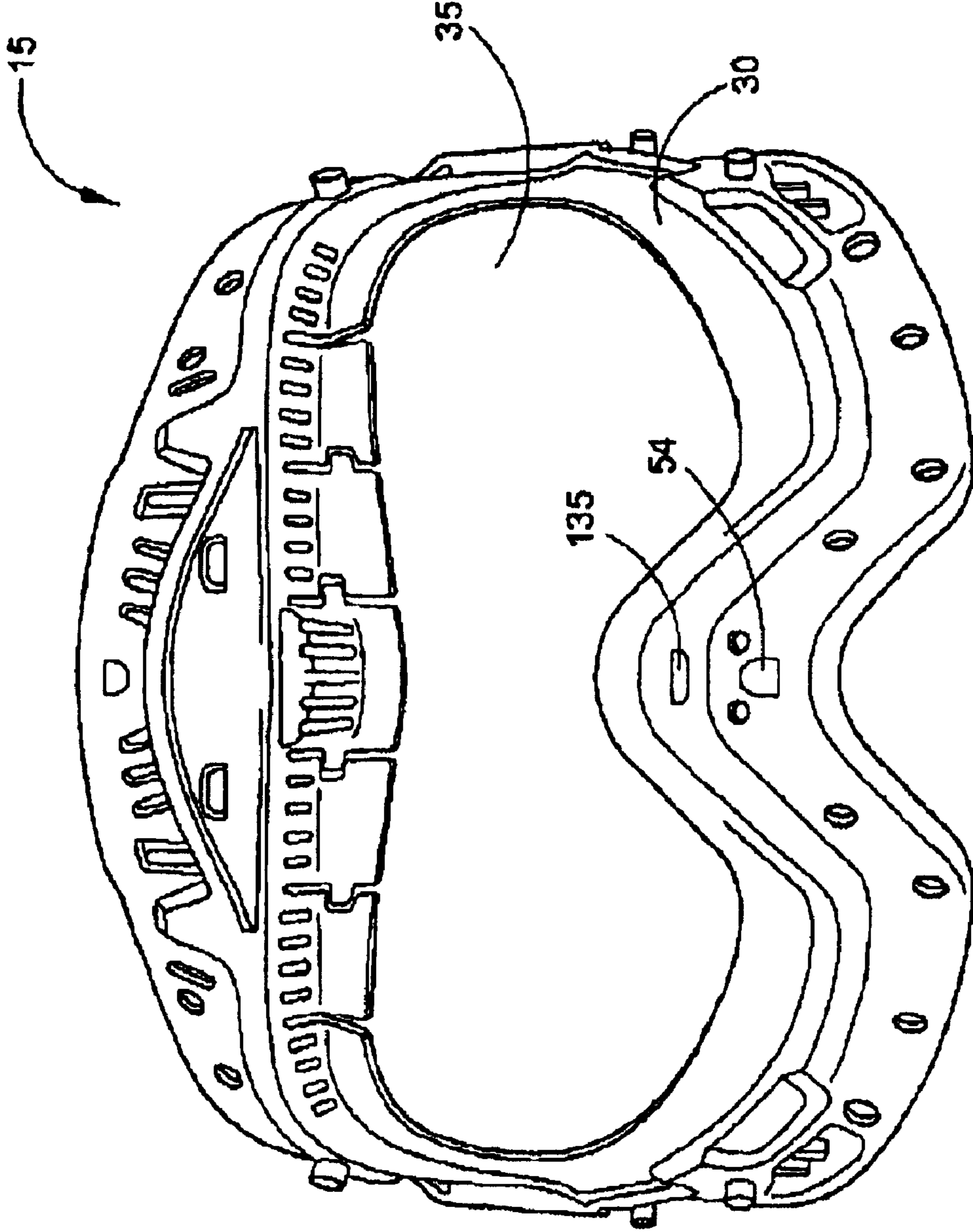

FIG. 1

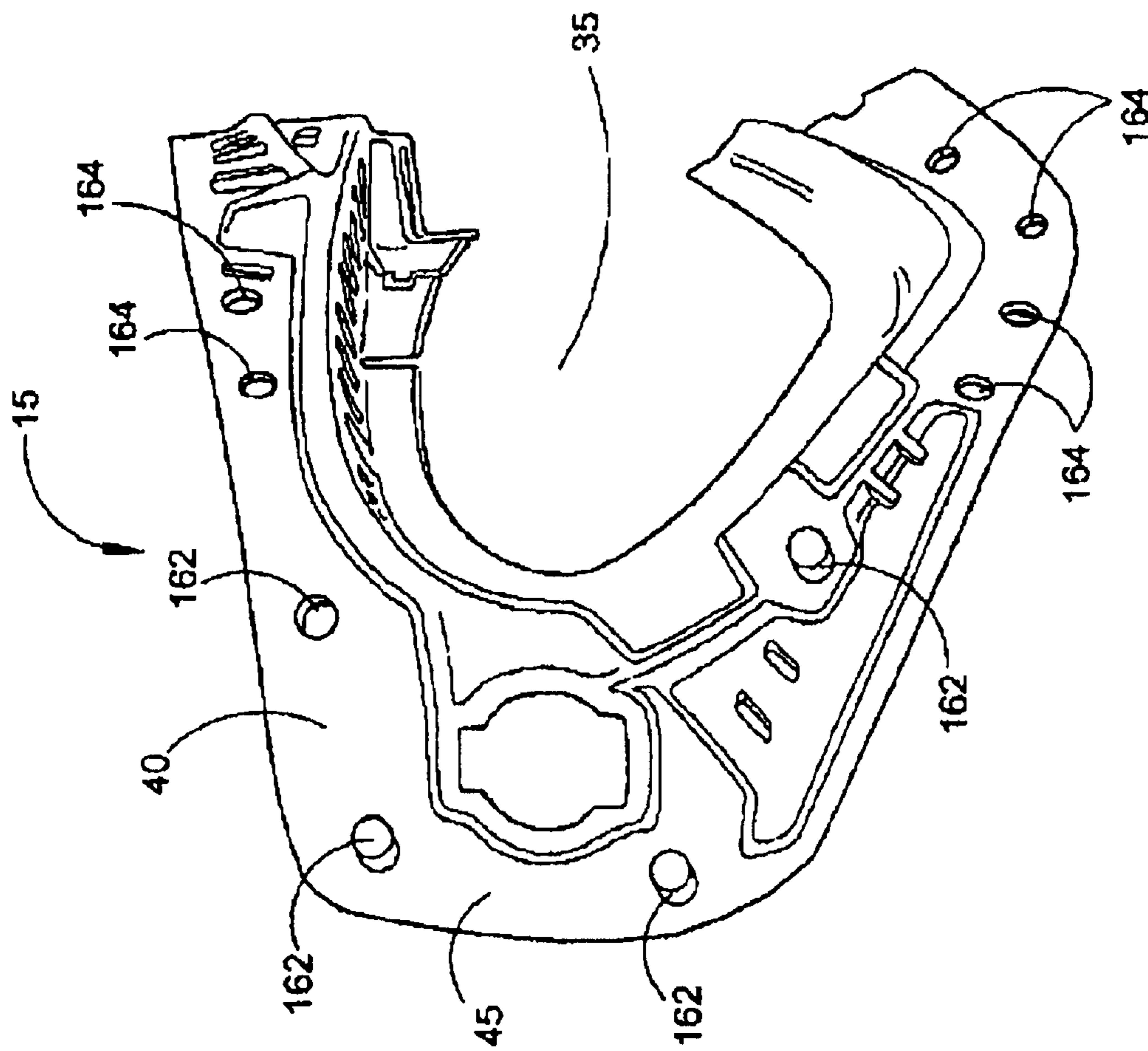
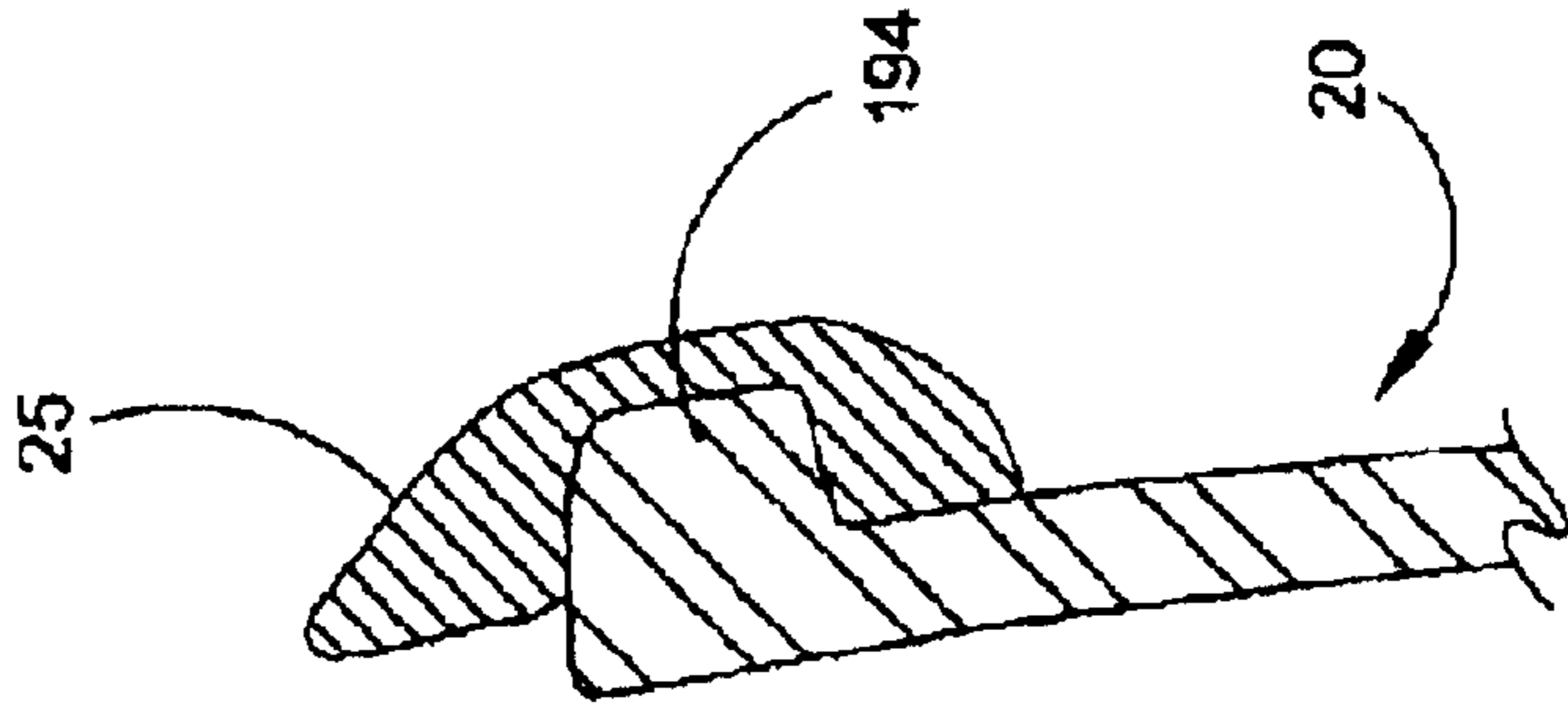
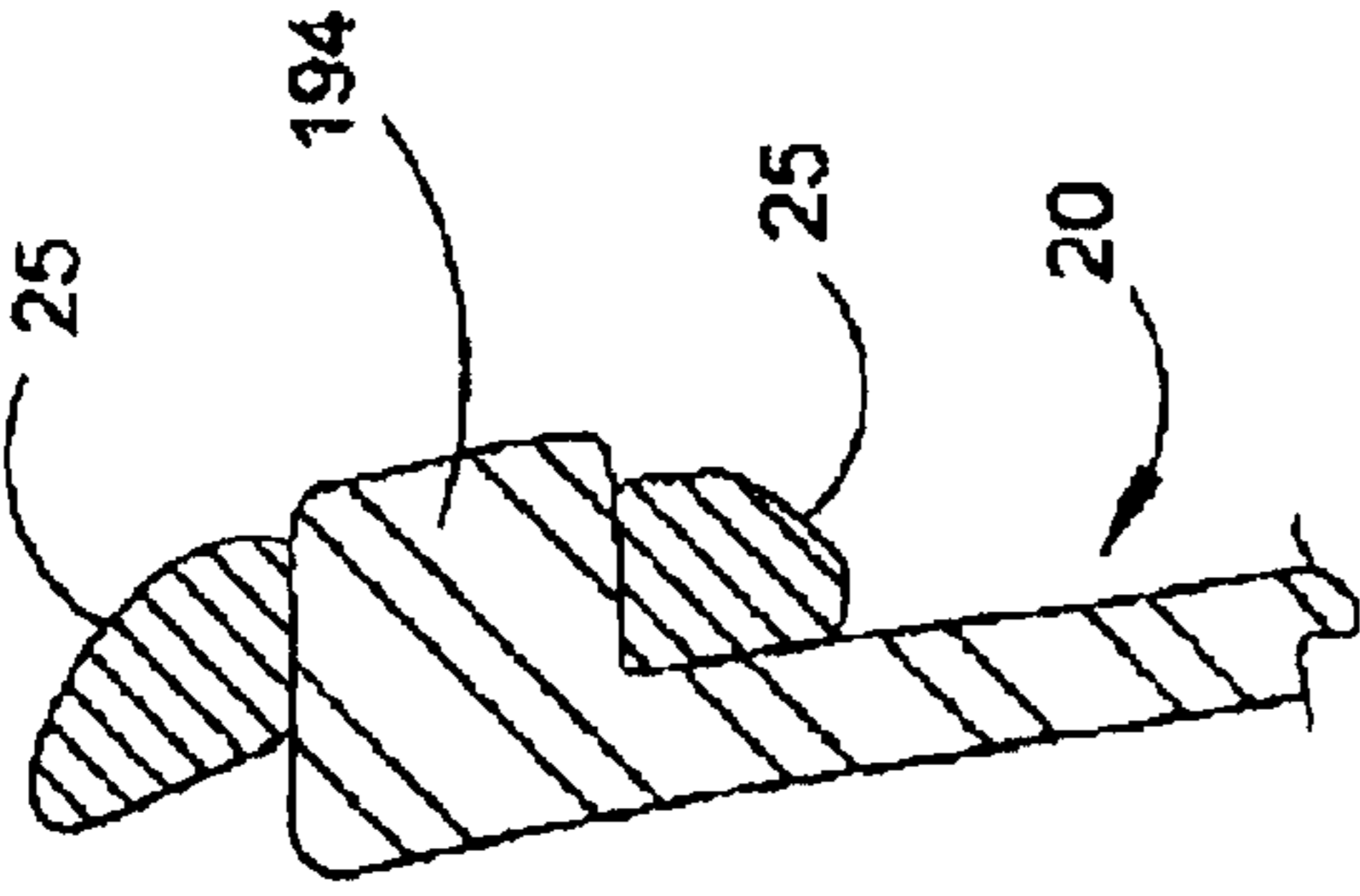
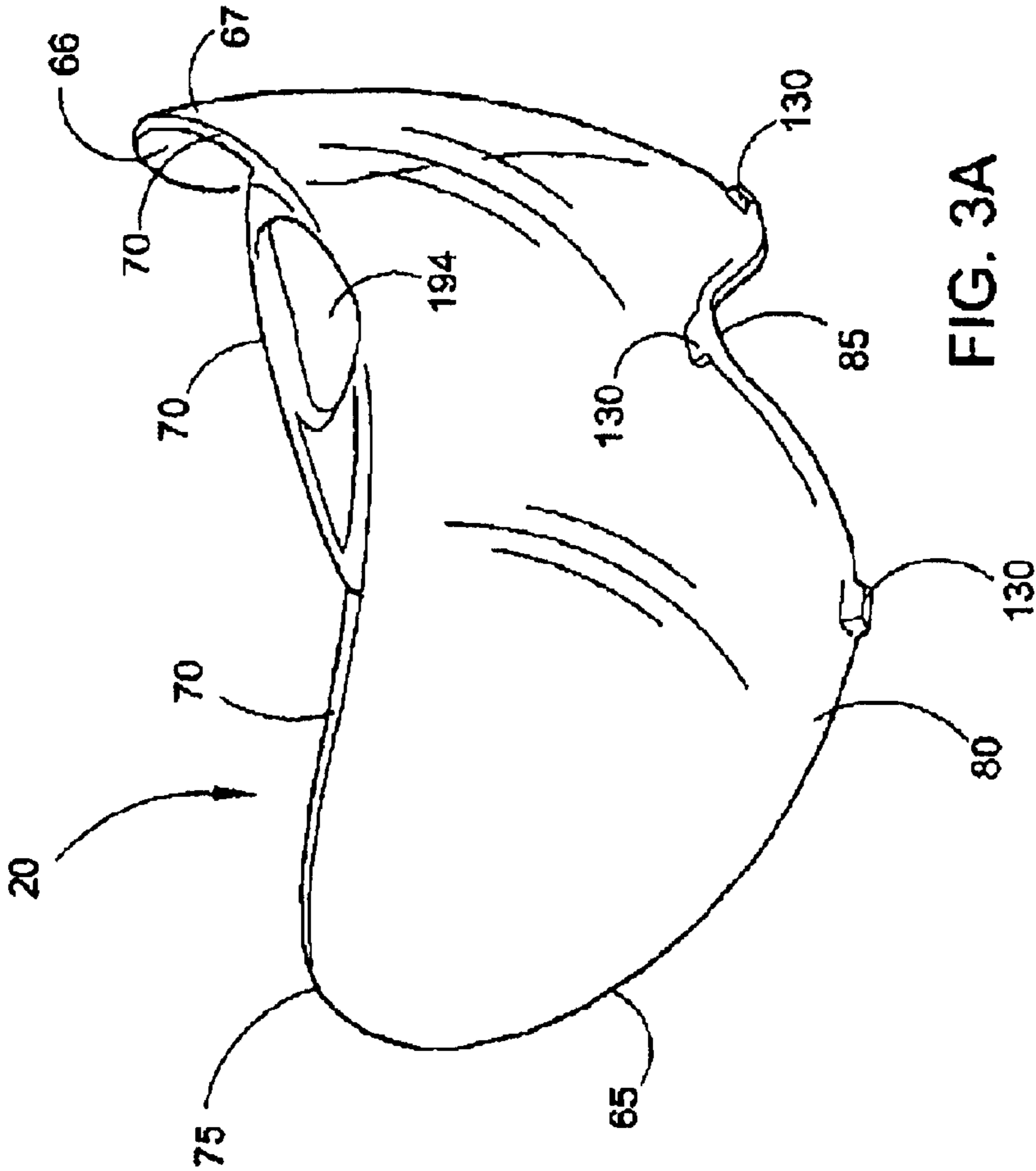

FIG. 2



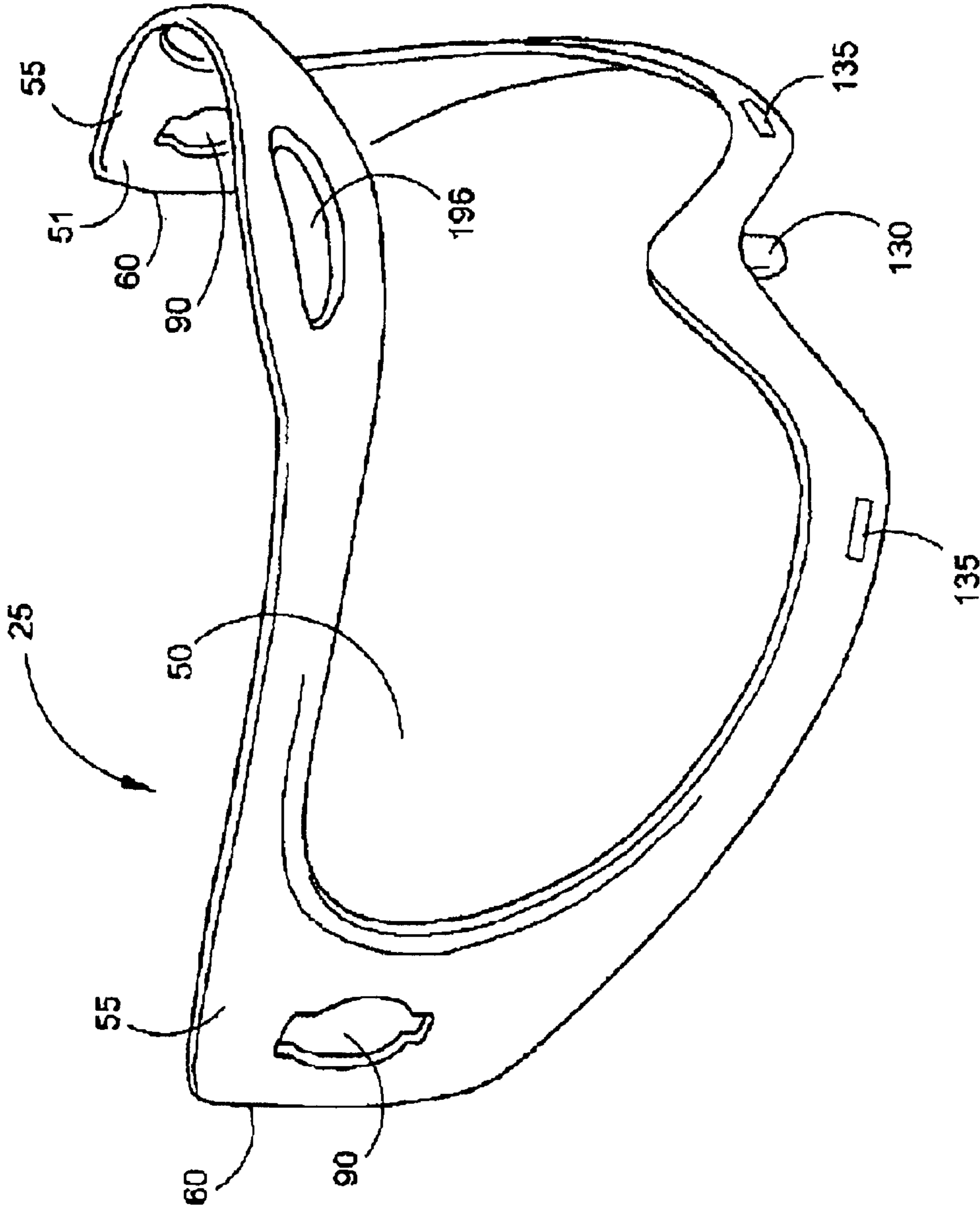
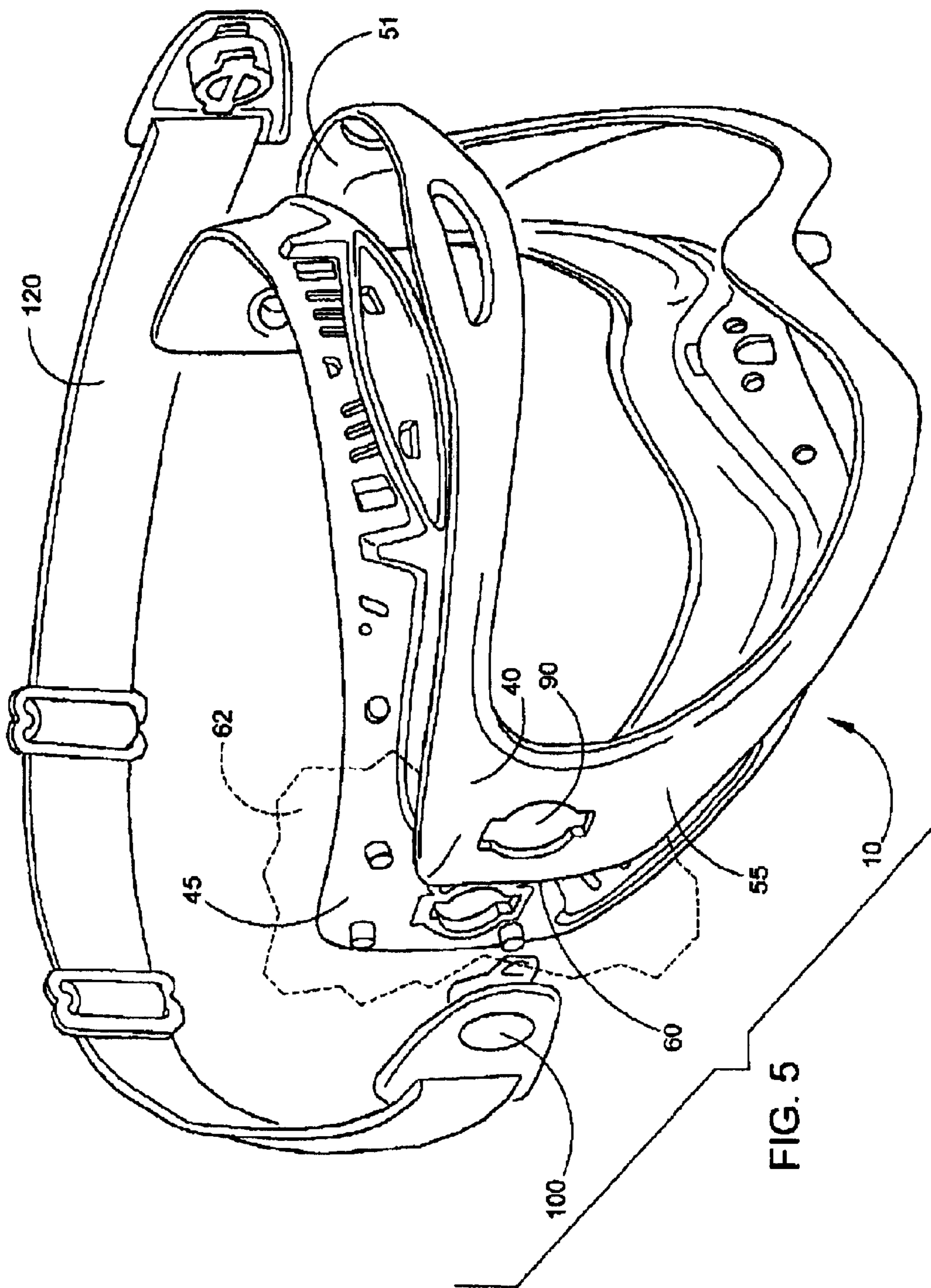

FIG. 4



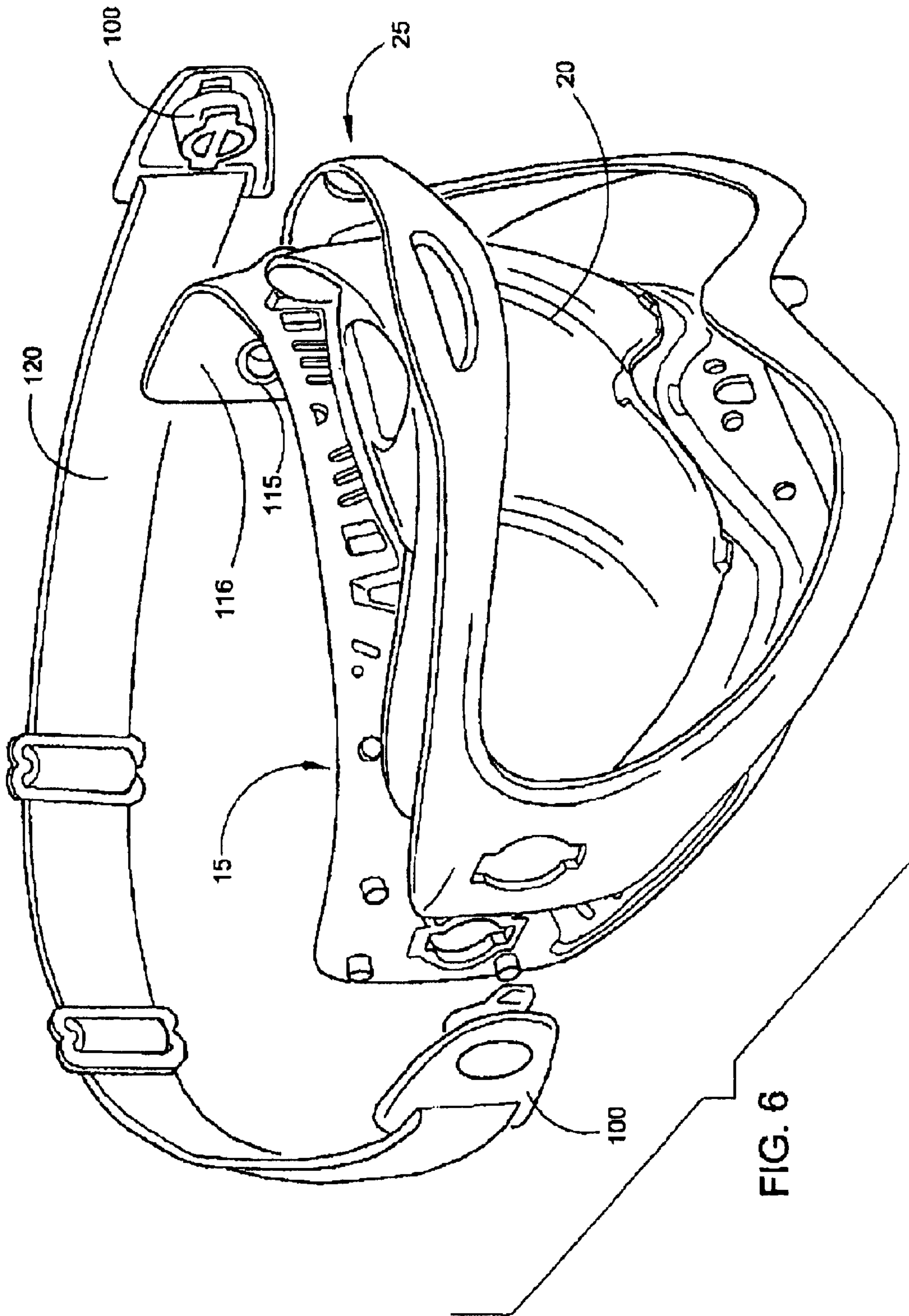
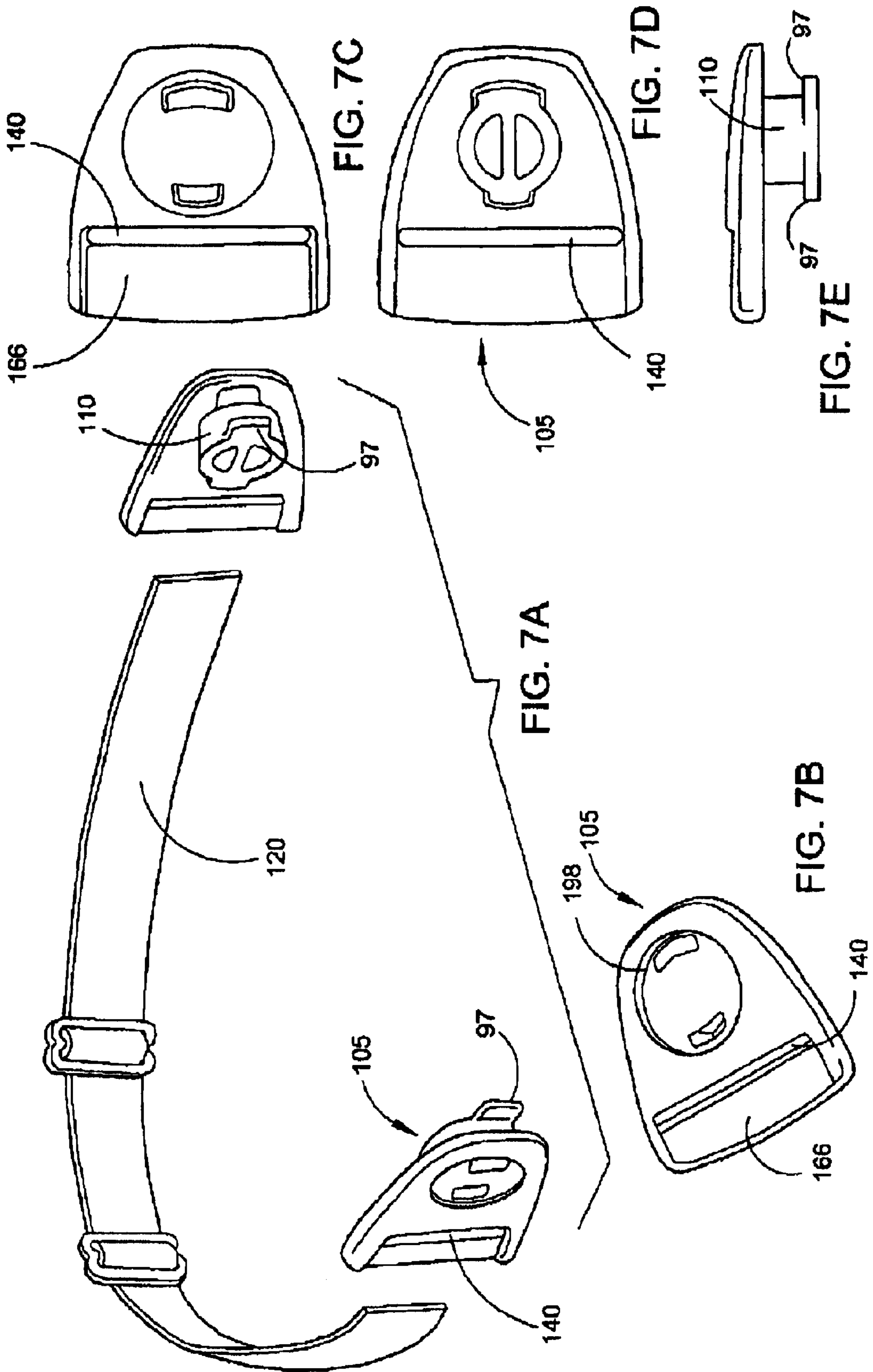

FIG. 6



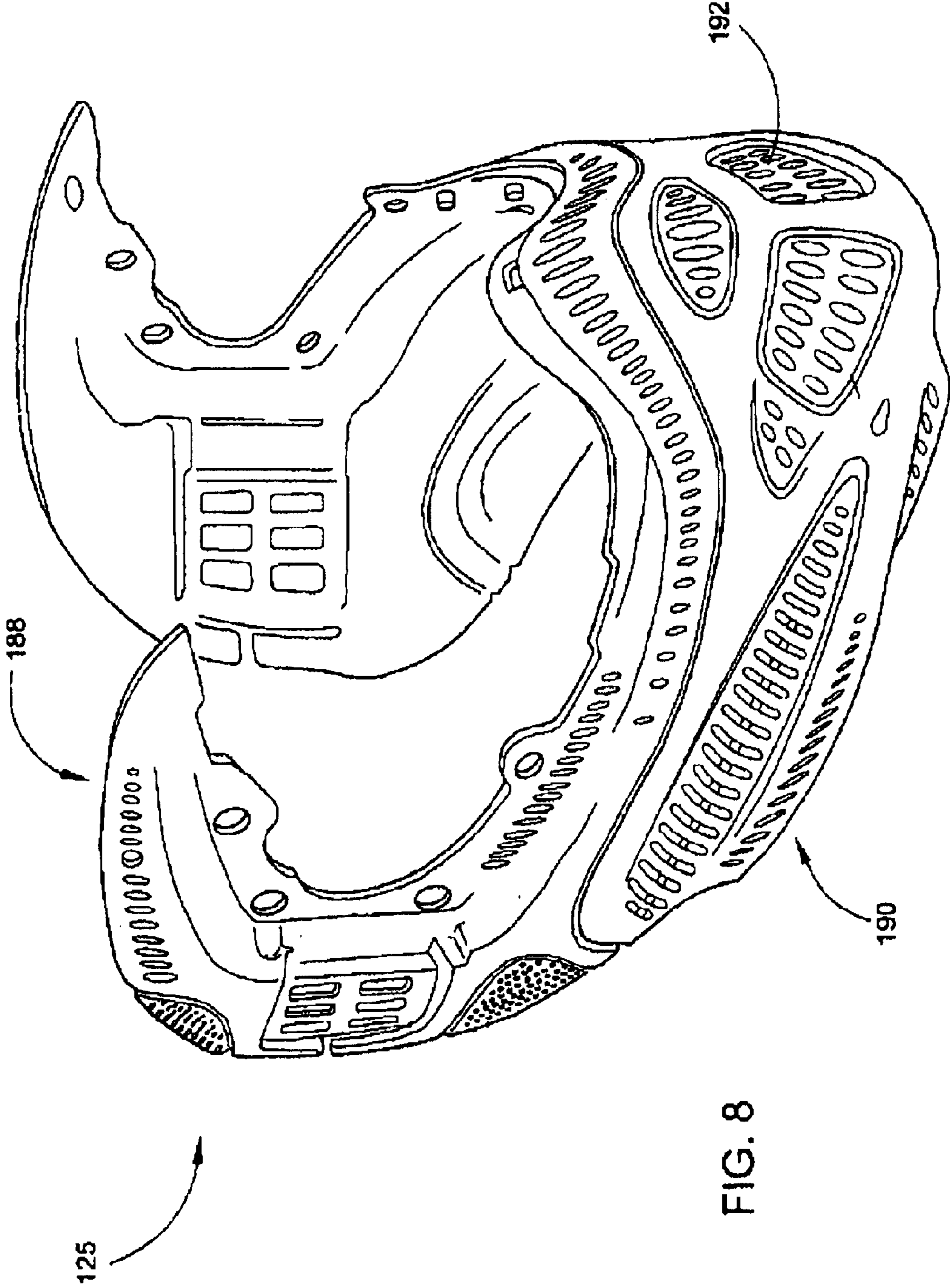

FIG. 8

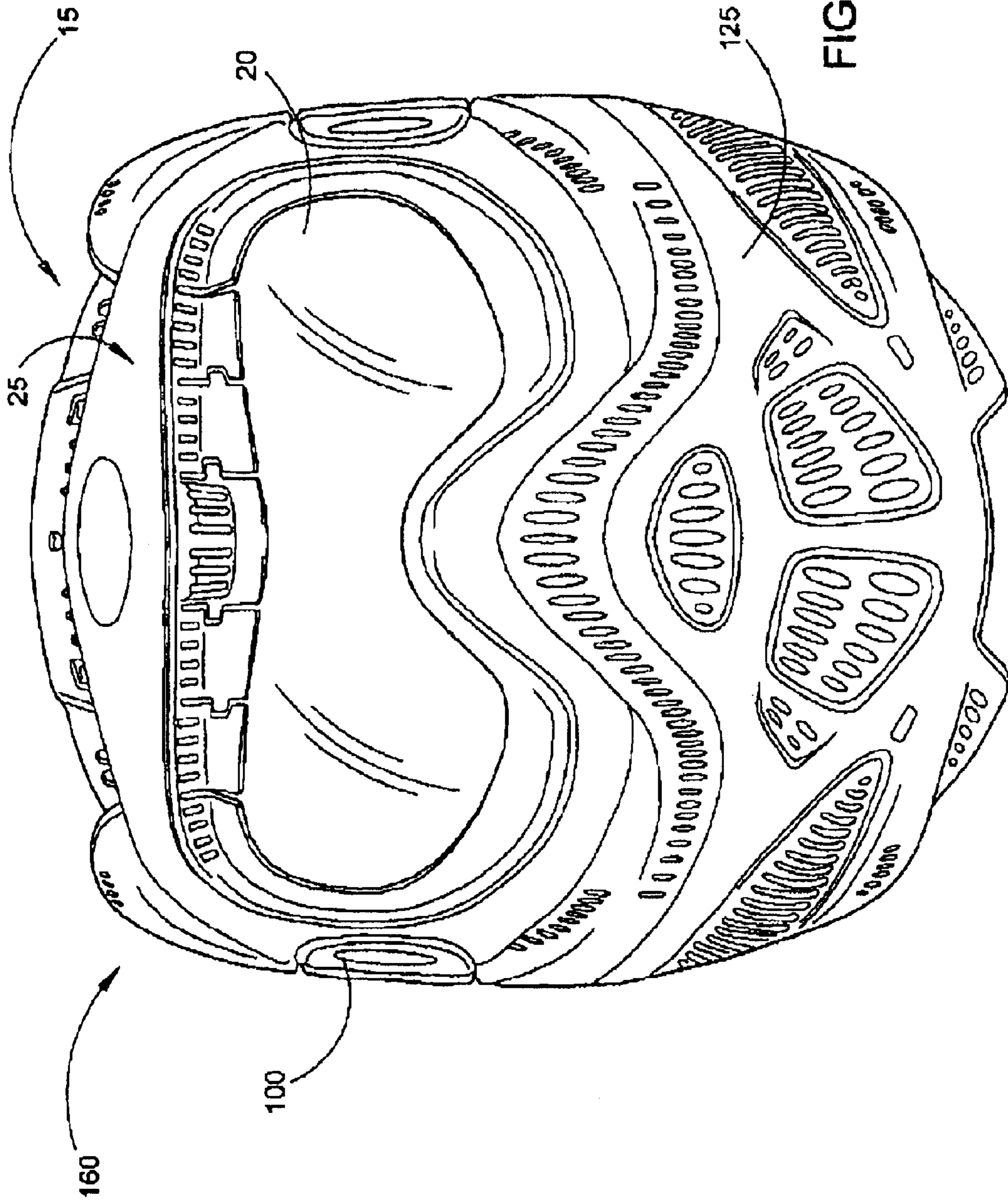

FIG. 9

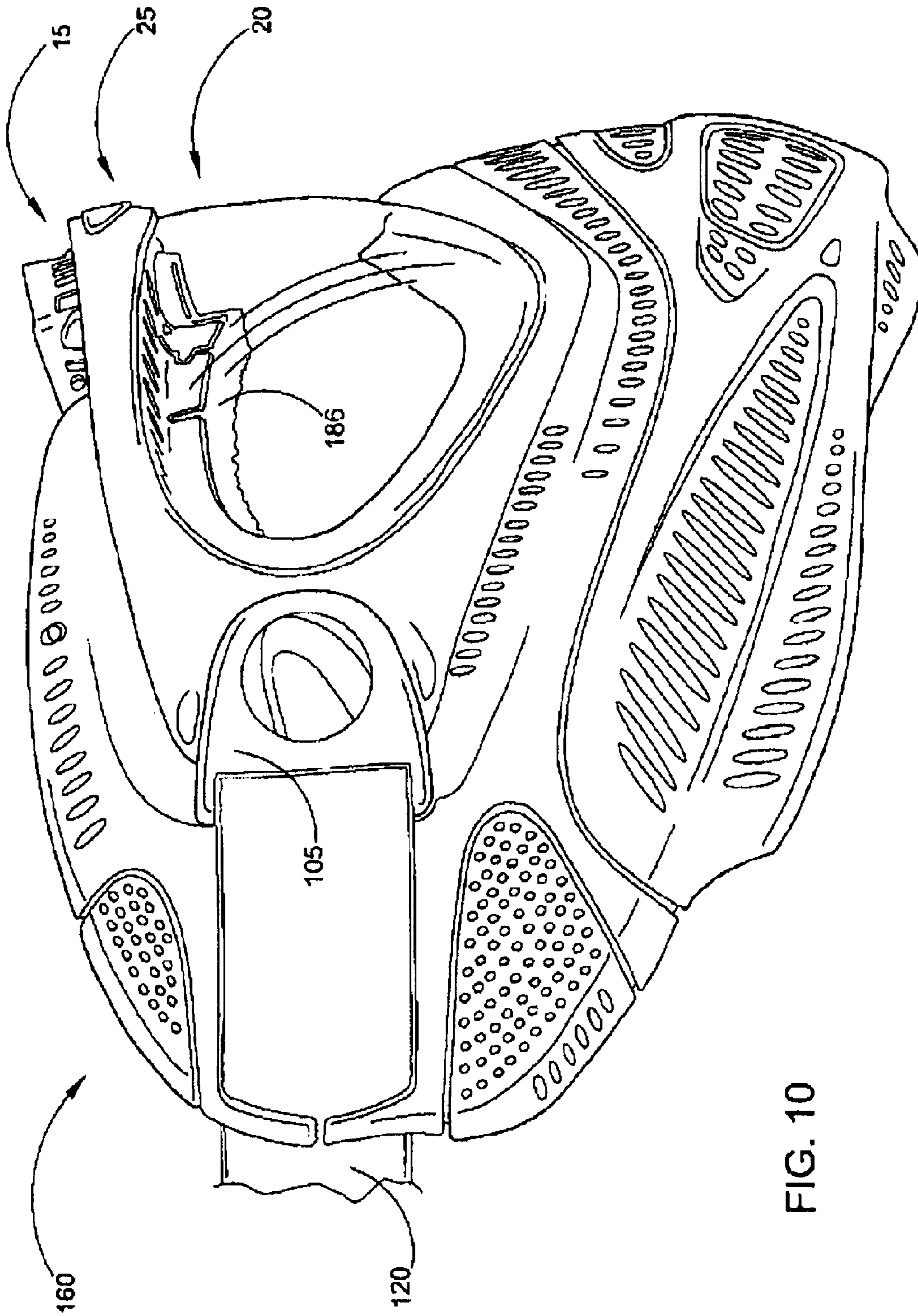

FIG. 10

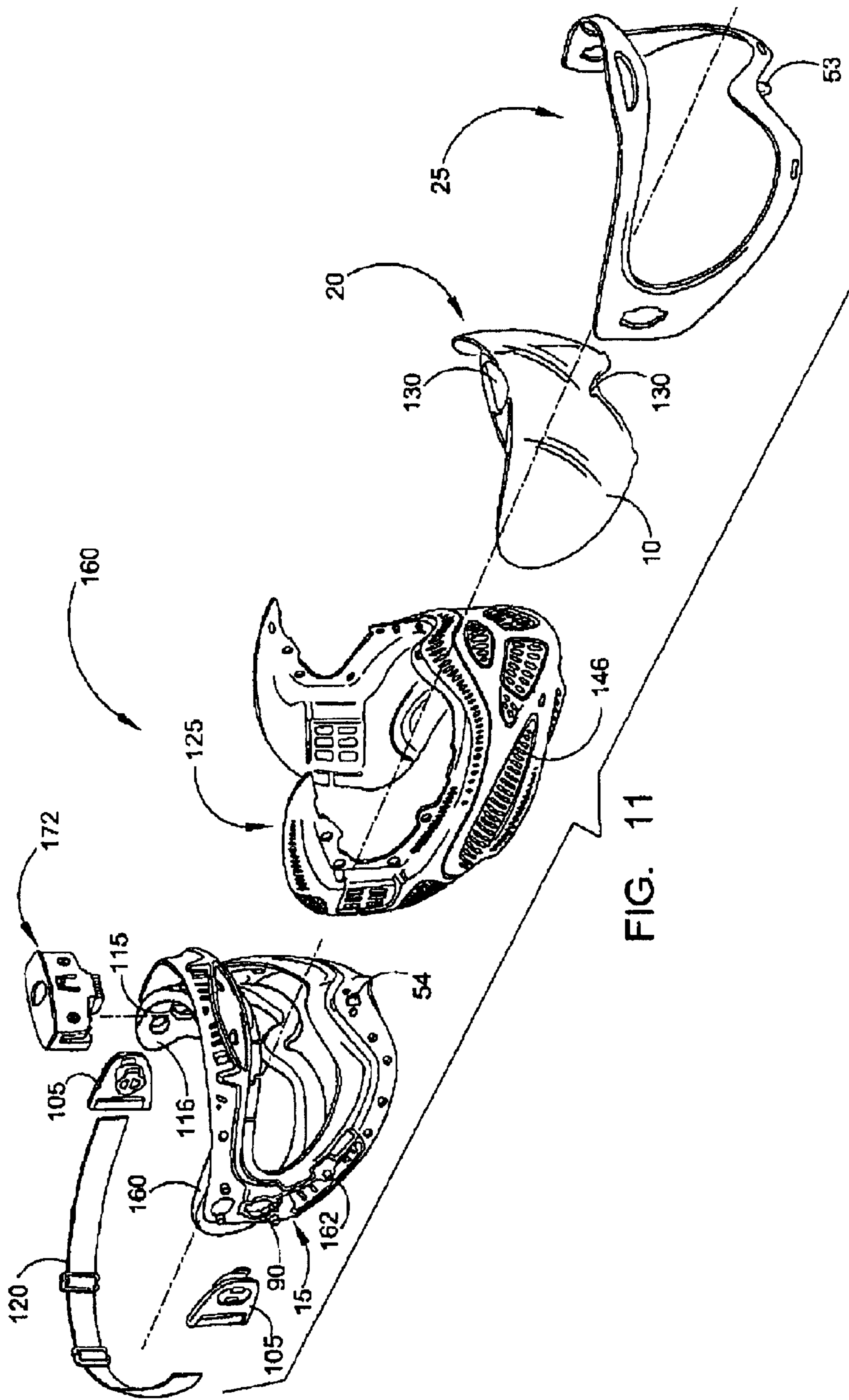
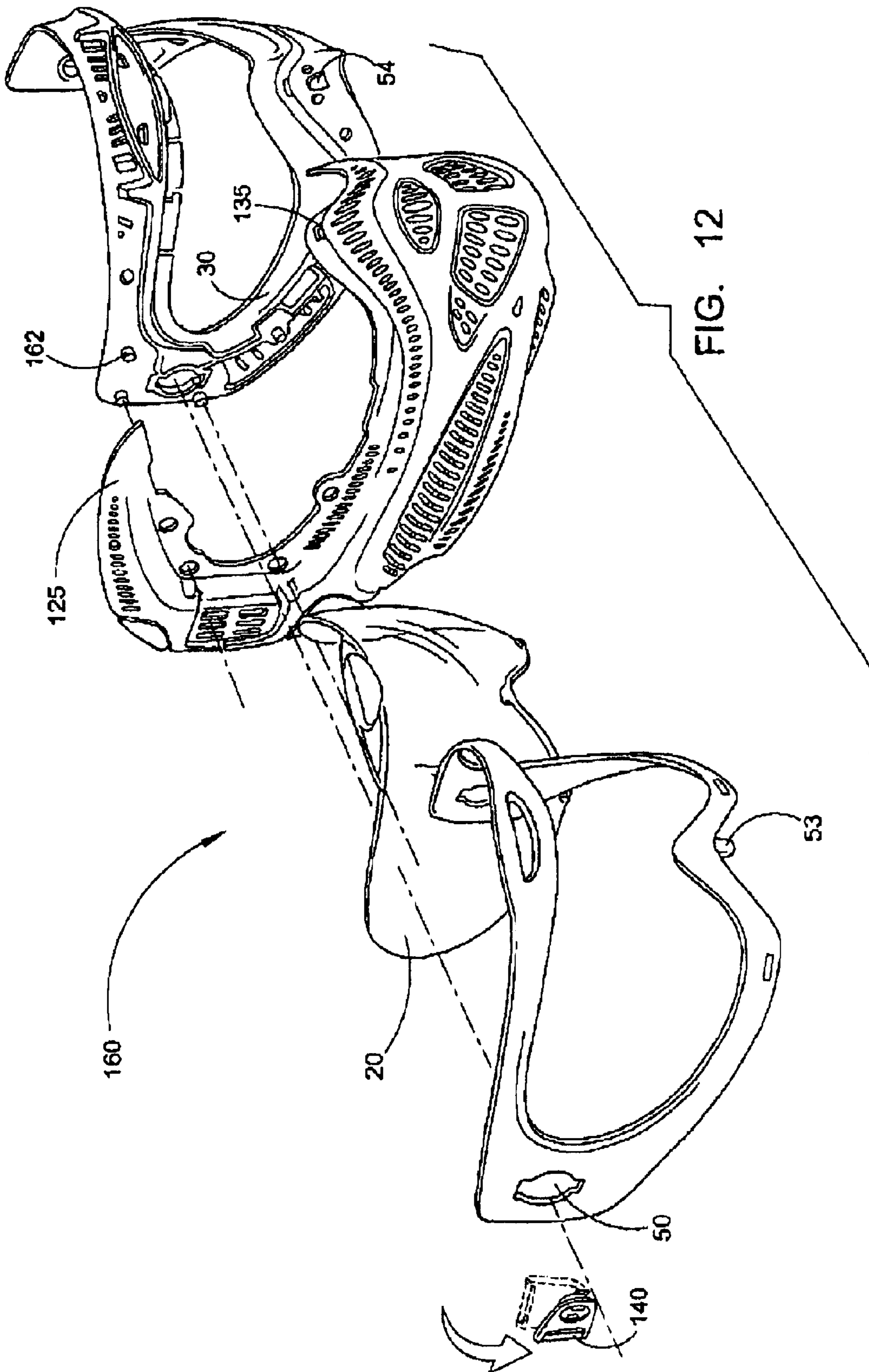

FIG. 11



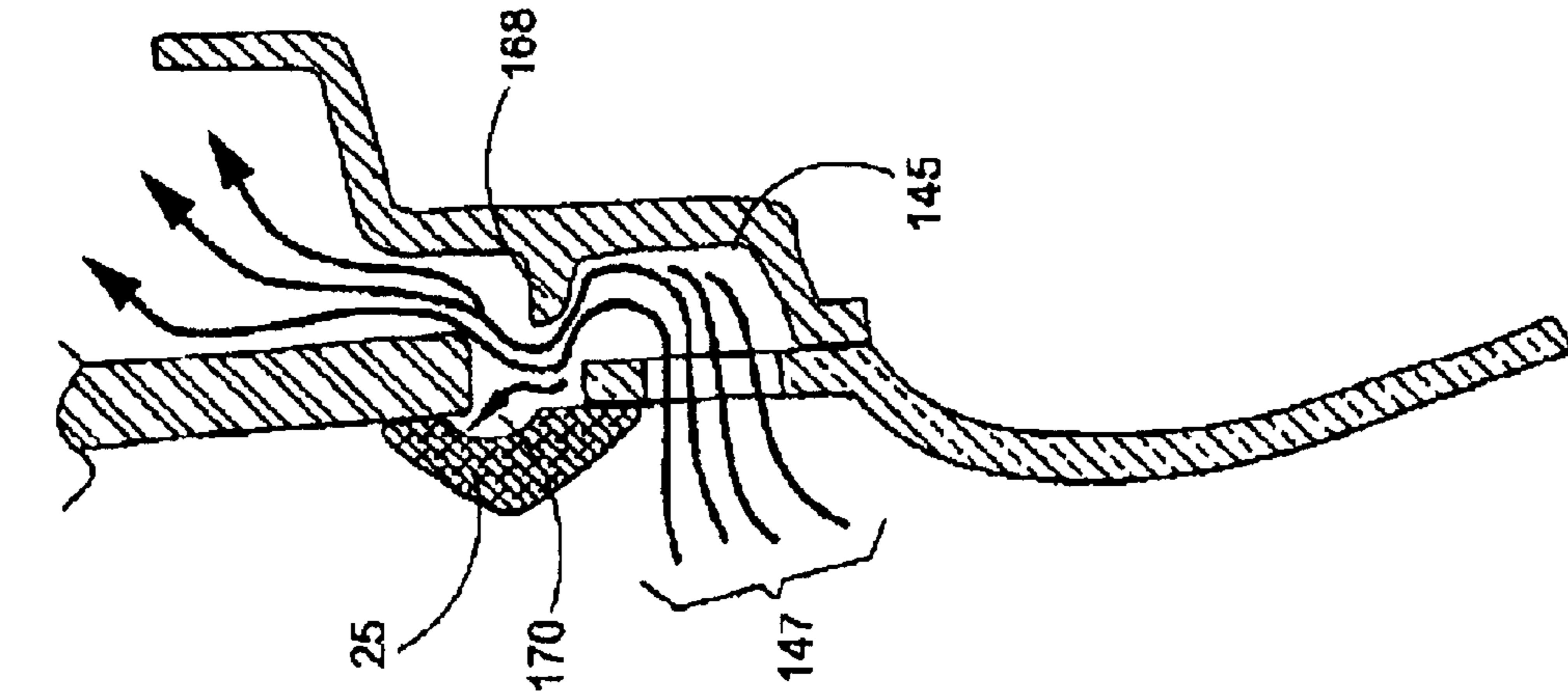

FIG. 13B

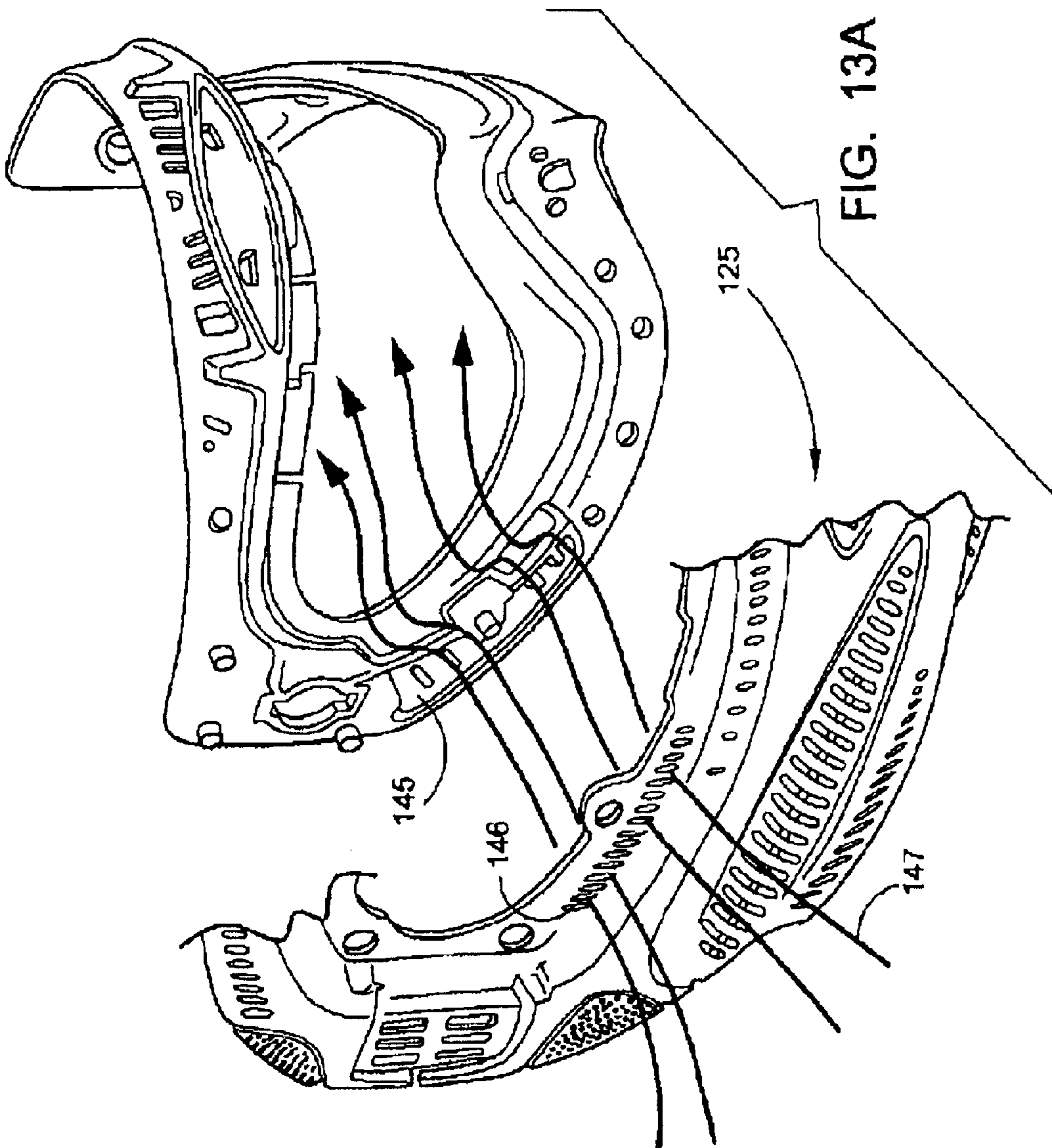
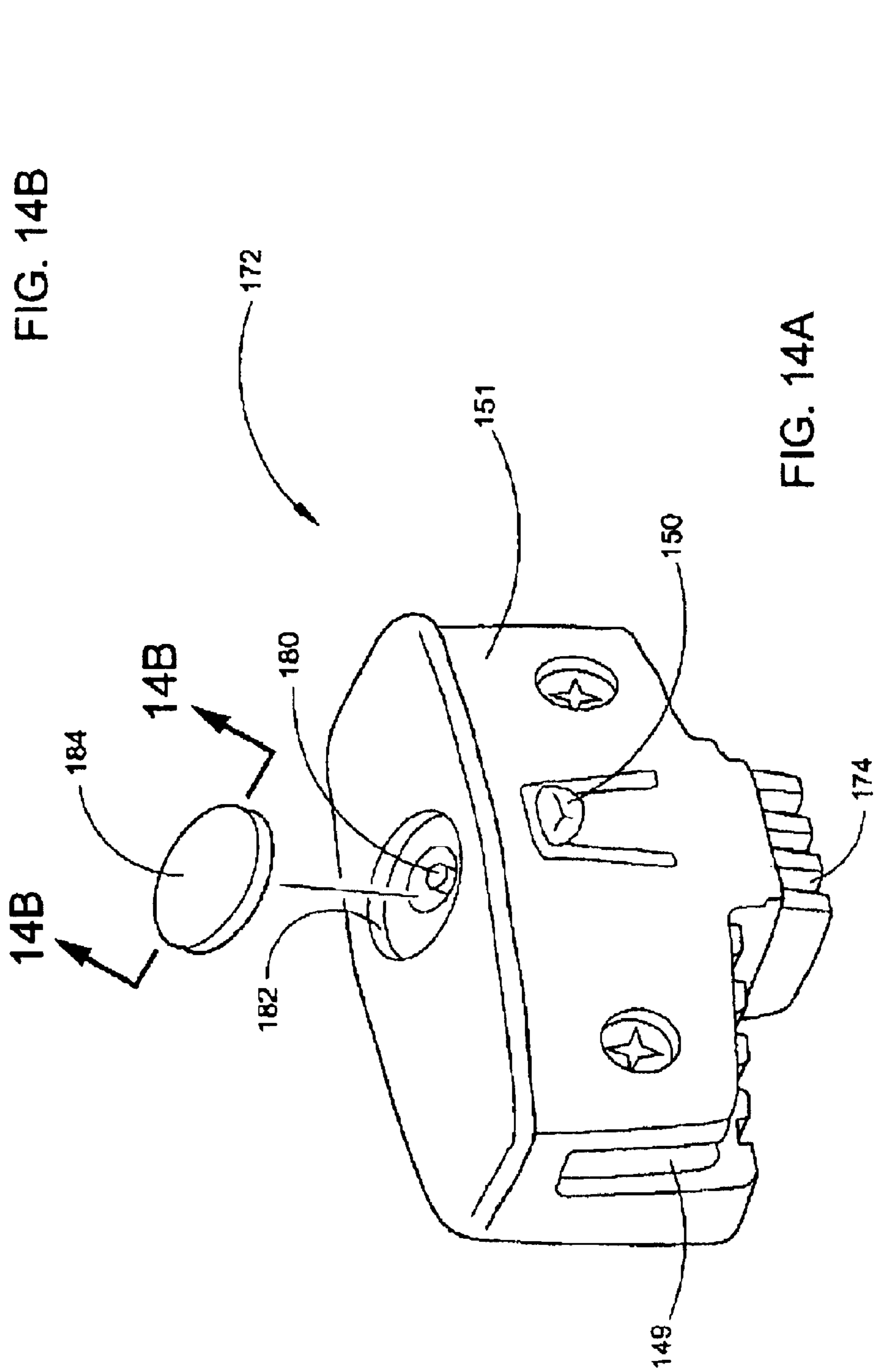

FIG. 13A



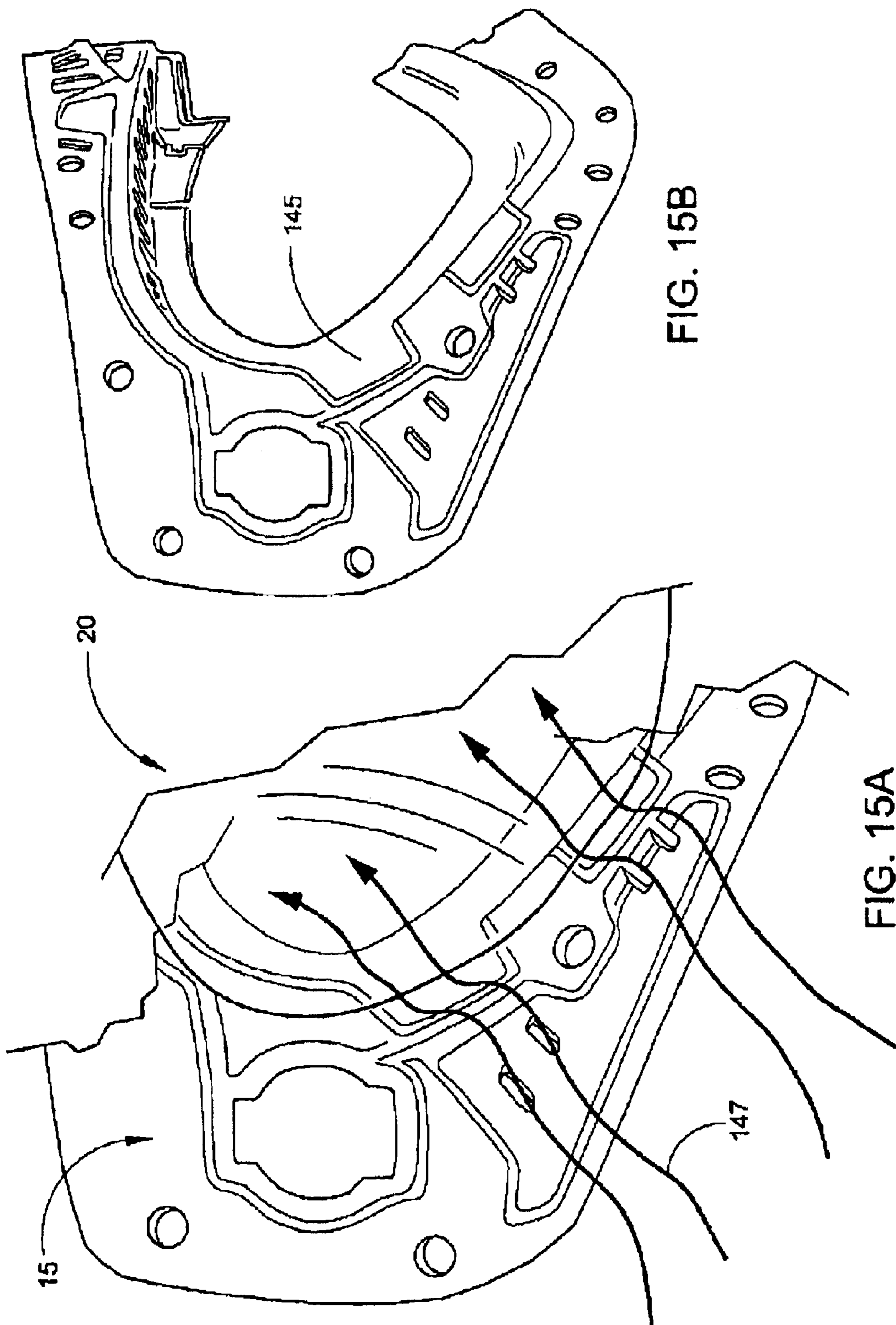
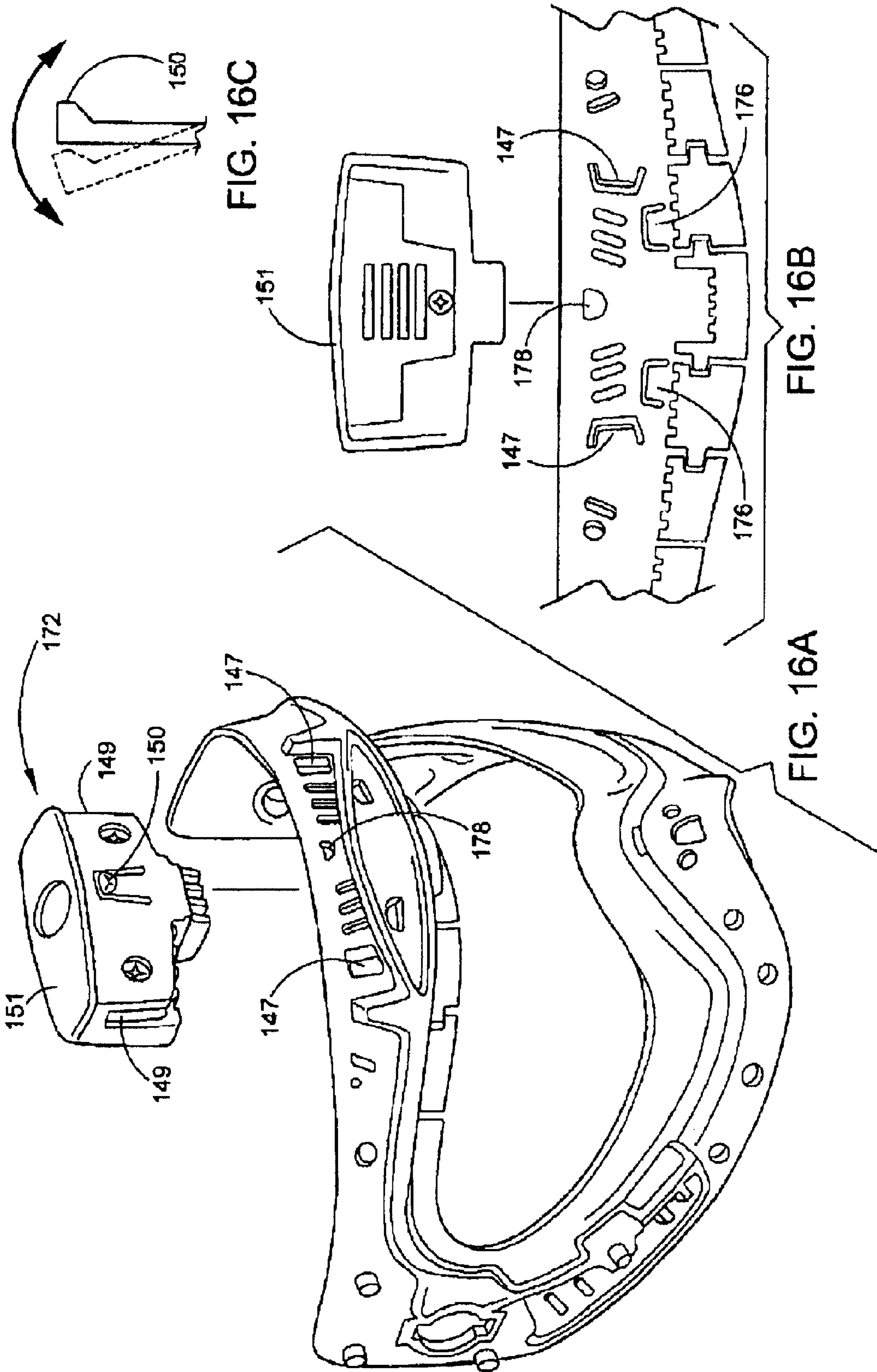

FIG. 15B

FIG. 15A



LENS ASSEMBLY PARTS AND ASSEMBLIES THEREFROM

Matter enclosed in heavy brackets [] appears in the original patent but forms no part of this reissue specification; matter printed in italics indicates the additions made by reissue.

FIELD OF THE INVENTION

The present invention relates to a set of lens-assembly parts for a protective goggle and to lens assemblies formed therefrom.

BACKGROUND OF THE INVENTION

Eye protection in sports, industry, military and police activities typically involves use of a goggle or lens assembly, often in association with a face mask in order to fully cover the face and the sides of the user's head. To prevent eye injury from impact by projectiles, splashed or projected liquids, and other flying objects, the lens is securely mounted in such assemblies to prevent dislodgement or disengagement from the assembly. Goggles or goggle-mask systems combinations are difficult to disassemble for changing lenses or for cleaning. The present invention addresses this problem, and provides a set of lens assembly parts and of assemblies therefrom for easy assembly/disassembly for replacing and/or cleaning the lens, for the replacement of other portions of the assembly, and for cleaning the assembly.

SUMMARY OF THE INVENTION

The invention is directed to sets of lens assembly parts and lens assemblies formed from the sets. In one aspect, a set of lens assembly parts comprises a base which is shaped to fit over the eyes and which has a lens receiving portion and a frame shaped for registration with the base. The base as well as the frame each comprise opposite temple portions. A lens, which is shaped to be positioned and secured between the base and the frame, may be included in the set. The opposite temple portions of the frame and the base comprise fasteners for tensioning the base against the frame and for securing the lens. The fasteners are inserted in registration openings which are formed in the frame and the base, and in which openings protrusion-retention elements (e.g. twist locks) are positioned. A version of the set of assembly parts contains a mask, which after assembly, is attached to the base. The set may contain a strap sized for fitting a lens assembly, which is made from the set of parts, to the head of the user.

Subjects of the invention further include lens assemblies formed from various combinations of lens-assembly parts.

BRIEF DESCRIPTION OF DRAWINGS

FIG. 1 is a front view of a base.

FIG. 2 is a side view of the base of FIG. 1.

FIG. 3 is a perspective view of a lens, and FIG. 3B-3C illustrate alternative placements of a logo tab of the lens in a corresponding slot.

FIG. 4 is a perspective view of a frame.

FIG. 5 is an exploded view of a lens assembly formed from a set of lens-assembly parts without a lens.

FIG. 6 is an exploded view of a lens assembly formed from a set of lens assembly parts including a lens.

FIGS. 7A-7E shows an exploded assembly of a twist lock cam fastener with a strap, and various views of a twist lock cam fastener.

FIG. 8 is a perspective view of a mask.

FIG. 9 is a front view of a lens assembly which includes a mask.

FIG. 10 is a side view of a lens assembly which includes a mask.

FIG. 11 is a first exploded view of a lens assembly including a mask and related elements.

FIG. 12 is a second exploded view of a lens assembly including a mask.

FIGS. 13A-13B shows holes in the mask and channels formed in the base to form a ventilation system and the related air flow.

FIGS. 14A-14B show a fan housing which is included in one set of lens assembly parts, and a cross-section of the logo disk housed in the fan housing.

FIGS. 15A-15B show side views of the air flow pattern under the lens, and of the channels formed in the base.

FIG. 16A discloses an exploded view of the base and fan housing; FIG. 16B shows an exploded view of the fan and the fan retention tabs on the mask; and FIG. 16C shows the flexing movement of the fan retention clip.

DESCRIPTION OF THE DRAWINGS AND THE INVENTION

In one aspect, the subject invention involves a set of parts for forming a lens-assembly. Included in the invention are different lens-assemblies formed from the set of parts.

The set of lens-assembly parts of the invention involves a base 15 which is formed of rigid or flexible plastic (FIGS. 1 and 2). The base is shaped to fit over the eyes. Formed in the base is a lens receiving portion 30 which is configured for receiving a lens 20 (FIG. 3). This lens receiving portion 30 defines a lens opening 35. Opposite temple portions 40 of the base extend rearward from the lens opening, and terminate in base terminal sections 45. A frame 25 (FIG. 4), also formed from rigid or flexible plastic material, is configured for mating alignment or engagement with the lens 20 to be positioned in the lens receiving portion 30 of the base. An opening 50 in the frame 25 registers with the lens opening 35 in the base 15. Opposite temple portions 55 of the frame extend rearward from the frame opening and terminate in frame terminal sections 60. In the lens assembly 10 (FIG. 5) formed therefrom, the opposite temple portions of the base and frame, respectively 40 and 55, are configured to be in juxtaposition in a lens assembly formed therefrom, forming opposite terminal regions 62 of the lens assembly of the invention.

When the set of lens-assembly parts is in operation, lens 20 is positioned or sandwiched between the base 15 and the frame 25 (FIG. 6). The lens 20 has a configuration which fits the lens receiving portion 30. The inner side 51 of the frame 25 is engaged with sections of the outer side 67 of the periphery 65 of the lens 20, namely, respective opposite brow 70, temple 75 and cheek 80, and nose 85 sections.

In a version of the set of lens-assembly parts, the opposite terminal regions 62 include fasteners 100. When releasably tightened or locked, the fasteners tension the lens receiving portion 30 of the base 15 and the inner surface 51 of the frame 25 against the inner and outer surfaces of the lens periphery 65, thereby fixing or clamping or otherwise securing lens 20 between the base 15 and the frame 25.

In one set of embodiments, the fastener 100 cooperates with registration openings 90 formed in the terminal section 45 and 60 of the frame and in the base. A coupler 105 extends into and about the registration openings 90 (FIG.

7A). Typically coupler **105** includes a protruding element **110** and a retention element that engages with registration openings **90**. Examples of couplers include, but are not limited to, twist lock cams **97** (a cam inserted through registration opening **90** and fitting into a cam channel formed about the side of registration opening **90** that is situated on the inner side of base **15**, (FIG. 6)). Other protruding elements **110** can be selected from bolts, rods, dowels, lugs, pins, rivets, and screws, while a retention element is selected for mating engagement with the protruding element. Retention elements are well known to those in the art, and include, without limitation, tightenable collars, annular members for frictional and/or snapping engagement with protrusion elements, and threaded openings. The fastener may also be formed in whole or in part from hook and loop materials positioned on or about the fastener in the terminal regions.

Preferred versions of the set of lens-assembly parts involve fasteners which the user can easily unfasten. Easy and quick unfastening results in easy, quick, and convenient disassembly of a lens assembly of the invention and removal of the lens **20** for cleaning or replacement, which is advantageous to the user. The base and frame can be easily cleaned and adjusted. In particular, quick and easy disassembly of the lens assembly allows the user to clean the peripheral portions of the lens **20**, the lens receiving area of the base **15**, and the inner surface **51** of the frame **25**. These areas collect solid or liquid debris that tend to corrode, craze, crack or otherwise weaken a lens, frame or base, and which are difficult to access for cleaning in conventional lens assemblies. Additionally, quick and easy disassembly allows replacement of the frame **25** with frames of other shape, size, color, design or ornamental design provided that a replacement frame is structured for registration with the base unit as described herein.

When fastener **100** comprises a twist lock cam **97**, slots of matching size to twist lock cam **97** are formed on surfaces of the frame **25** and base **15**, the slots being in juxtaposition to define registration opening **90** and to secure lens **20** between the frame **25** and the base **15**. Twist lock cams **97** and registration openings **90** are sized and positioned to correspondingly mate into sufficiently tight engagement (snapping engagement) to secure the lens, typically with a $\frac{1}{4}$ turn of protruding element **110**, yet be subject to easy unfastening by the user with a reverse $\frac{1}{4}$ turn. Fastener **100** and registration openings **90** may be positioned in the terminal region or in the regions or in the region of the base **15** and frame **25** which fit over the user's brow, cheeks, nose or any combination of those regions or sections of the base **15** and frame **25** so long as they are arranged and sized for snapping engagement and easy unfastening. Continuous or discrete areas of hook and loop fabrics can be positioned on surfaces of the frame **25** and base **15** which will be in juxtaposition for securing lens **20** between the frame **25** and the base **15**. Interengagement of the hook and loop surfaces achieves securing of the lens **20** between the frame **25** and the base **15**.

Another embodiment of the set of lens-assembly parts involves a fastener which is a clamp or sliding clip which fits about the terminal portions of the opposite temple portions of the base **15** and **25**. A fastener takes the form of a flexible band which wraps about the opposite temple portions and tightly engages, securing the lens **20** between the base **15** and the frame **25**. Hook and loop material disposed on a band provides surfaces on the band for interengagement and tightening. It is preferred to use a wrapping fastener that is easily untightened.

Another version of the set of lens assembly parts further comprises a strap **120** (FIGS. 5, 6, 7A, and 11) which is

attached to couplers **105**. The strap **120** is sized for the head of the user and fits the lens assembly to the head.

It is understood that fastening the frame **25** to the base **15**, which sandwiches the lens **20** into a secure position, is achieved by one or a combination of the above-enumerated structures and devices, and that the invention is not limited to embodiments which do not comprise more than one of the above so enumerated structures and devices.

Another embodiment of the set of lens-assembly parts further comprises a mask **125** (FIG. 8) for engagement with the base **15**, to provide for a mask system **160** (FIG. 12). The mask **125** is shaped or configured to cover at least a portion of the face. As shown in FIGS. 9 and 10, the mask section is configured to cover the user's nose, chin, lateral and temple regions of the forehead, and cheeks. The mask is formed from plastic which can have a durometer rating varying from soft to hard, depending on the requirements of the user for impact protection. A preferred version of the mask is formed from semi-soft plastic having two hardness levels, and which are co-molded as one piece. As shown in FIG. 8, the mask may comprise an upper portion **188** made of a semi-soft plastic material, and a lower portion **190** having different degree of softness. For instance, ventilation vanes **192** may be grouped in clusters and made of a plastic material softer than the remainder of lower portion **190**.

Methods of molding plastics are well known in the art. One method of making a mask comprises the use of materials having more than one hardness and shaped by using a two-shot injection molding process, wherein both the harder and softer materials are sequentially injected in the same mold. Two-shot injection molding processes are known in the art, and thus will not be described in detail. During the hardening of the rigid plastic and rubbery materials in the two-shot molding process, a chemical bond is formed at the junction of the two materials, thereby permanently bonding the two materials together. This type of molding process provides for ease of manufacture, and further provides a long lasting construction. The manufacture of the set of lens-assembly part or lens assembly of the invention is not limited to the molding procedure described above.

The base **15**, frame **25** and lens **20** are advantageously inter-engaged through a series of tabs **130** and slots **135** formed therein, and which are sized and positioned to correspondingly mate into engagement (FIGS. 1, 3, 4, 11 and 12). FIG. 1 discloses a base **15** which contains lens one or more lens retention slots **135**. FIG. 4 illustrates a frame in which slots **135** are formed on the periphery. FIG. 3 illustrates a lens **20** in which tabs **130** are formed in the periphery. The tabs **130** and slots **135** of the base **15**, lens **20**, and frame **25** are positioned in registration so that, as shown in FIG. 11, tabs **130** of the lens **20** fit in registered slots of the base **15** and slots of the frame **25** (in the embodiment shown in FIG. 3, one nose tab extends rearwards and one tab in each cheek region extends forward). Further, a logo tab **194** extends to fit in logo slot **196**, and may be visible to an outside observer (FIG. 3B) or hidden (FIG. 3C). Such a tab-slot combination prevents a vertical movement of lens **20**, yet provides for an easy assembly and disassembly of lens **20** between base **15** and frame **25**. Such easy assembly and disassembly is further expedited by the use of fasteners **100** that can be locked in position with only a $\frac{1}{4}$ turn, as explained above.

FIGS. 6 and 11, which are exploded view of the lens assembly **160**, illustrate registration openings **90** formed in opposite terminal sections of the frame **25** and the base **15**. Inserted through each registration opening **90** is a coupler **105**, such as a coupler comprising twist lock cam **97** (FIG.

5

7A). Lock cam 97 fits in a cam chamber 115 formed on the inner surface 116 of the base 15 and located about the registration opening 90. The lock cam 97 travels into the cam chamber 115; upon twisting lock cam 97 by a ¼ turn, lens 20 is secured in place between the frame 25 and the base 15. Merely twisting in another direction by a reverse ¼ turn unlocks lens 20, releasing the pressure which kept the lens 20 secured between the frame 25 and the base 15. Unfastening one or both fasteners 100 leads to rapid, easy disassembly of the lens assembly.

FIGS. 9, 10 and 11 illustrate a version of the invention in which the set of lens-assembly parts, and the mask system 160 formed therefrom, includes mask 125 attached to the base 15. Although FIG. 2 illustrates that the mask 125 is attached to the base 15 via a system of registered pins 162 and slots 164 (for instance, a total of twelve slots 164 along the upper and lower central portions of base 15, and a total of eight pins 162 along the sides of base 15), the attachment of the mask 125 to base 15 is not limited to the embodiment illustrated here. The mask 125 may be permanently attached to the base 15, for example without limitation, by adhesives, co-molding, staples, screws. Alternatively, the mask 125 may be clipped, latched or otherwise removably secured with the base 15.

FIG. 2 is a side view of a base 15 in which mask-attaching holes 164 and pins 162 are formed and located in registration with mating holes and pins formed in the mask 125 (FIG. 8). FIG. 11 illustrates assembly of mask system 160. The registration holes and pins of the base 15 and mask 125 are aligned and mated, thereby attaching the mask 125 to the base 15. The lens 20 and frame 25 are assembled by aligning and mating the registration tabs 130 of the lens 20 with slots 135 on base 15 and frame 25. The nose areas of the lens-frame assembly and the base-mask assembly are aligned. The nose pin 53 on the frame 25 is inserted through an aligned nose pin hole 54 on the base 15, which achieves placement of the lens 20 into the lens-receiving portion 30 of the base. The openings in the opposite terminal sections 45 and 60 are aligned providing registration openings 90 and a coupler 105 is inserted through the registration opening 90. The user twists twist lock cam 97 by ¼ turn, thereby locking the lens 20 between the base 15 and the frame 25.

FIG. 11 schematically shows the alignment of the frame 25, lens 20, mask 125, base 15, and coupler 105, as well as the strap 120. The strap 120 is attached to the coupler 105 (See FIGS. 7A–7E). A strap slot 140 formed in coupler 105 retains or attaches the strap 120 to the coupler 105, which when inserted and locked into the registration openings 90, achieving attachment of the strap 120 to the lens assembly. A strap depression 166, adjacent to strap slot 140, provides stability to strap 120. Further, a logo depression 198 provides a suitable area for positioning a promotional logo. In any case, strap receiving elements, such as slots, fingers, frames may be formed on the base, or on the frame; and/or clips or clipping mechanisms, hinged clipping mechanisms, buckles, rivets, screws, adhesives for attaching a strap to the lens assembly may be positioned in the terminal regions of the lens assembly, and are preferably integral with the fastener 100, or in some instances, the strap may be molded directly into a terminal region of the lens assembly.

As shown in FIGS. 13A–13B and 15A–15B, the base 15 is provided with a series of gutters or concavities which form channels 145 to provide ventilation to the user's face. Each of channels 145 may comprise one or more segments. In the version of the lens assembly which comprises a mask 125, the mask 125 is preferably provided with a series of holes 146 in a position corresponding to channels 145, so to pro-

6

vide air flow 147 over the user's face. The operation of channels 145 may be better understood with reference to FIG. 13B. A baffle 168 delimits one end of channel 145, Air flow 147 is free to enter hole 146, flow over baffle 168 and reach the user's face. Instead, liquid substances impacting mask 125 (for instance, paintball during paintball games) are prevented from reaching the user's face by baffle 168, which deviates the liquid substance 170 in the direction of frame 25. Air flow through the recessed areas of channel 145 and under lens 20.

FIGS. 11, 14, and 16A–16B depict a lens assembly in which a battery-powered fan 172 is mounted on the central brow or forehead of the base 15. Fan 172 comprises a housing 151, on which there are side slots 149, bottom slots 174, and a retention clip 150. On base 15 there are instead side retention tabs 147, in position matching side slots 149, and bottom retention tabs 176, in positions matching bottom slots 174. The side and bottom retention tabs 147 and 176 hold the fan housing 151 tight against the back of the forehead area. As the fan housing is slid down between the side tabs 147, the fan retention clip 150 contacts the top center edge of the base. While inserting the fan housing 151, the retention clip 150 flexes back and snaps into the retention hole 178 (FIG. 16C). Fan 172 is activated by an on/off button switch 180, which is situated inside a depression 182 on housing 151. A logo disk 184 may optionally be positioned over on/off button switch 180, logo disk 184 being in a position that is essentially flush with housing 151. Logo disk 184 serves the double function of providing an aesthetically pleasing finish to housing 151 (displaying a logo if desired), and also of serving as an on/off button switch within easy reach of the user.

The set of lens assembly parts may further include a layer of material 186, for instance, foam, for cushioning and/or absorbing sweat, the layer being mounted on the inner side of the base 15 (FIG. 10).

What is claimed is:

1. A set of lens-assembly parts comprising:

- (a) a base [shaped to fit over the eyes, the base] having a lens-receiving portion, one or more first slots situated around the periphery of the lens receiving portion, and opposite temple portions, each temple portion having a first opening;
- (b) a frame having an inner surface and an outer surface, the frame comprising one or more second slots and opposite temple portions, each of the temple portions having a second opening, [the frame being shaped for registration with the base,] wherein the first and second openings are in matching positions to jointly define a registration opening;
- (c) a lens [shaped] for positioning between the base and the frame, the lens having a plurality of tabs extending from the [lens in direction substantially perpendicular to the] outer and inner surfaces of the lens and cooperating with the first slots and second slots; and
- (d) one or more fasteners for tensioning the base against the frame, each of the fasteners engaging one registration opening.

2. The set of claim 1, further comprising a mask attached to the base, the mask being shaped for covering at least a portion of [the] a face, the mask being secured to the base and comprising a plurality of ventilation vanes.

3. The set of claim 2, wherein one or more fasteners comprise couplers, each of the couplers comprising:

- (a) a cap positioned against one end of the registration opening formed in said frame and said base;

7

(b) a retention element positioned against the opposite end of the registration opening, and

(c) a protruding element extending through the registration opening and connecting the cap and the retention element.

4. The set of claim 3, further comprising a strap for attachment to each of said couplers.

5. The set of claim 3, wherein the retention element is a twist lock cam of elongated shape, wherein the registration opening has a matching elongated shape, and wherein the twist lock cam is secured in position by a one-quarter turn around the longitudinal axis of the protruding element.

6. The set of claim 5, wherein the twist lock cam is secured in position within a groove defined at the matching end of the registration opening.

7. The set of claim 3, wherein the cap comprises a depression suited for lodging a disk carrying a decorative design.

8. The set of claim 3, wherein the at least one of the couplers comprises a slot for attaching a strap, and a depression for lodging a portion of the strap.

9. The set of claim 2, wherein the mask is secured to the base by a plurality of pins extending from the base into matching opening in the mask, and by a plurality of pins extending from the mask into matching openings in the base.

10. The set of claim 2, wherein the ventilation vanes are grouped in clusters.

11. The set of claim 10, wherein the mask is of molded plastic, and wherein the ventilation clusters are molded from a plastic of different hardness than the remainder of the mask.

12. The set of claim 2, wherein the base comprises one or more ventilation channels, wherein some of the plurality of mask ventilation vanes are in matching positions to the ventilation channels, and wherein the ventilation channels comprise one or more baffles to deflect a liquid impacting the ventilation vanes away from the face of the user while enabling the passage of air from the ventilation vanes to the face of the user across the ventilation channels and under the lens.

13. The set of claim 1, wherein said one or more fasteners comprise hook and loop fabric.

[14. A lens assembly formed from the set of lens-assembly parts of any of claims 1, 2, 3, 4 and 13.]

15. The set of claim 1, wherein at least one of the second slots extends through the entire thickness of the frame, the at least one of the second slots enabling the corresponding lens tab to be visible on the outer surface of the frame and to display a decorative design situated on the corresponding lens tab.

16. The set of claim 1, wherein the frame comprises a pin extending from the nose area of the frame and mating with a corresponding opening in the base.

17. The set of claim 1, further comprising a battery-powered fan having a housing, the fan being secured to the base and activated by an on/off switch.

18. The set of claim 17, wherein the on/off switch is positioned within a depression in the housing, and wherein a button of matching size is positioned within the depression, the button enabling the activation of the on/off switch and being suitable for displaying a decorative design.

19. The set of claim 17, wherein the housing comprises a retention clip and one or more slots, wherein the retention clip flexes during the positioning of the fan on the housing and then engages with a matching opening on the base when the fan reaches its operative position, and wherein the one or more slots on the housing engage with matching retention tabs on the base when the fan reaches its operative position.

8

20. The set of claim 1, further comprising one or more foam layers attached substantially around the lens receiving portion of the base, the one or more foam layers being attached to the side of the base opposite to the lens.

[21. A lens assembly formed from the set of lens-assembly parts of any of claims 5–20.]

22. *A set of goggle components comprising:*

at least one first member being configured to be positioned against the temples of a user and having a first opening;

a second member having a second opening and being disposed so that the first and second openings are in substantially matching positions to jointly define a registration opening; and

a fastener configured to rotate relative to the registration opening and between a first position and a second position, a portion of the fastener being sized and shaped to pass through the registration opening at least when the fastener is in the first position, the fastener compressing the at least one first member toward the second member at least when the fastener is in the second position.

23. *The set of goggle components of claim 22, wherein the fastener comprises:*

a cap disposed against one end of the registration opening;

a retention element disposed against the opposite end of the registration opening; and

a protruding element extending through the registration opening and connecting the cap and the retention element.

24. *The set of goggle components of claim 23, wherein the retention element is a twist lock cam having an elongated shape, and wherein the registration opening has a generally matching elongated shape.*

25. *A set of goggle components for use with a removable lens, the goggle components comprising:*

a base having a first opening;

a frame having a second opening, at least a portion of the second opening being aligned with at least a portion of the first opening; and

a removable fastener rotatable relative to the first and second openings and between a first position and a second position, a portion of the fastener being configured to pass through the first and second openings at least when the fastener is in the first position, the fastener being rotatable to the second position so as to compress the base toward the frame at least when the lens is disposed between at least a portion of the base and at least a portion of the frame.

26. *The set of goggle components of claim 25, wherein the fastener rotates approximately one-quarter turn between the first position and the second position, and wherein the fastener is removable from the base at least when the fastener is in the first position.*

27. *The set of goggle components of claim 25, wherein the fastener rotates about a longitudinal axis of the fastener.*

28. *The set of goggle components of claim 25, wherein the fastener comprises a twist lock cam.*

29. *The set of goggle components of claim 25 further comprising a strap, the strap being removable from the base at least when the fastener is in the first position and removed from the first and second openings, the strap being attached to the base at least when the fastener is disposed in the first and second openings and rotated to the second position.*

30. *The set of goggle components of claim 29, wherein the fastener includes a slot, at least a portion of the strap passing through the slot.*

9

31. The set of goggle components of claim 25, wherein each fastener comprises a slot for receiving a head strap.

32. The set of goggle components of claim 25, wherein the first and second openings define a passage and the fastener comprises:

- a cap disposed against one end of the passage;
- a retention element disposed against the opposite end of the passage; and
- a protruding element extending through the passage and connecting the cap and the retention element.

33. The set of goggle components of claim 32, wherein the retention element is a twist lock cam having an elongated shape, and wherein the passage has a generally matching elongated shape.

34. The set of goggle components of claim 32, wherein the fastener rotates about around a longitudinal axis of the protruding element.

35. A goggle for use with a removable lens, the goggle comprising:

- a base having a first opening;
- a frame having a second opening;
- a fastener rotatable when in the first and second openings and between a first position and a second position, the fastener compressing the frame towards the base at least when the fastener is in the second position and the removable lens is disposed between at least a portion of the base and at least a portion of the frame; and
- a strap secured to the fastener.

36. The goggle of claim 35, wherein the fastener comprises a slot, and wherein the strap is secured to the slot.

37. The goggle of claim 35, wherein the strap is releasable from the base and frame at least when the fastener is rotated to the first position and removed from the first and second openings, and wherein the strap is secured relative to the base and the frame at least when the fastener is disposed in the first and second openings and rotated to the second position.

10

38. The goggle of claim 35, wherein the fastener rotates approximately one-quarter turn between the first position and the second position.

39. A goggle for use with a removable lens, the goggle comprising:

- a base having a lens-receiving portion and two first openings;
- a frame having two second openings disposed so as to align with the first openings;
- a head strap;

a first attachment member having a first receiver for receiving an end portion of the head strap, the first attachment member being configured to rotate when disposed within one of the aligned first and second openings and between a first position and a second position, the first attachment member being removable from the base and frame at least when in the first position, the first attachment member tensioning the base against the frame at least when a portion of the removable lens is disposed within the lens-receiving portion and the first attachment member is in the second position; and

a second attachment member having a second receiver for receiving an end portion of the head strap, the second attachment member being configured to rotate when disposed within one of the aligned first and second openings and between a first position and a second position, the second attachment member being removable from the base and frame at least when in the first position, the second attachment member tensioning the base against the frame at least when a portion of the removable lens is disposed within the lens-receiving portion and the second attachment member is in the second position.

* * * * *