



US00RE41821E

(19) **United States**
(12) **Reissued Patent**
Ross et al.

(10) **Patent Number:** **US RE41,821 E**
(45) **Date of Reissued Patent:** **Oct. 12, 2010**

(54) **CONTROL OF MULTIPLE POWER PLANTS AT A SITE TO PROVIDE A DISTRIBUTED RESOURCE IN A UTILITY GRID**

(75) Inventors: **Ricky M. Ross**, Ellington, CT (US); **Francis A. Fragola, Jr.**, Wallingford, CT (US); **Herbert C. Healy**, Windsor, CT (US); **Douglas Gibbons Young**, Henderson, NV (US)

(73) Assignee: **UTC Power Corporation**, South Windsor, CT (US)

(21) Appl. No.: **11/019,150**

(22) Filed: **Dec. 21, 2004**

Related U.S. Patent Documents

Reissue of:

(64) Patent No.: **6,757,590**
Issued: **Jun. 29, 2004**
Appl. No.: **09/808,762**
Filed: **Mar. 15, 2001**

(51) **Int. Cl.**
G05D 11/00 (2006.01)

(52) **U.S. Cl.** **700/286; 700/22; 429/12; 429/13**

(58) **Field of Classification Search** **60/603; 429/12, 13; 700/3, 9, 22, 286, 291, 295, 298; 903/902, 906, 907, 908, 944; 307/23, 64; 323/207; 363/34, 65**

See application file for complete search history.

(56) **References Cited**

U.S. PATENT DOCUMENTS

4,004,947	A	1/1977	Bloomfield	429/17
5,315,533	A *	5/1994	Stich et al.	700/298
5,401,589	A	3/1995	Palmer et al.	429/13
5,573,867	A	11/1996	Zafred et al.	429/17
5,579,197	A	11/1996	Mengelt et al.	361/93
5,621,654	A *	4/1997	Cohen et al.	700/287
5,686,766	A *	11/1997	Tamechika	307/43

(Continued)

OTHER PUBLICATIONS

Gilbert, "The Nations largest fuel cell project, a 1 MW fuel cell power plant deployed as distributed generation resource, Anchorage, Alaska project dedication Aug. 9, 2000", IEEE 2001, 1 page.*

Schwartzenberg et al., "15 kV Medium Voltage Static Transfer Switch", Silicon Power Corporation, IEEE 1995.*

Wald, "Energy to Count on; Fuel Cells Tapped as Power Source for Computer Systems", The New York Times, Aug. 1999.*

De Miglio, "Anchorage mail processing center to be powered by world's largest commercial fuel cell system", USPS, Aug. 1999.*

"Fuel Cells for Distributed Generation", Energy Center Of Wisconsin, Mar. 2000.*

(Continued)

Primary Examiner—Paul L Rodriguez

Assistant Examiner—Carlos Ortiz Rodriguez

(74) *Attorney, Agent, or Firm*—Stephen A. Schneeberger

(57) **ABSTRACT**

A site management system (11) is provided for a power system (8) at site in a utility distribution grid (10). The power system (8) includes multiple [fuel cell] power plants, e.g., fuel cells, (18) and one or more loads (14), for selective connection/disconnection with the grid (10). The site management system (11) controls the power plants (18) in an integrated manner, alternatively in a grid connected mode and a grid independent mode. The multiple power plants (18) at the site may be viewed and operated as a unified distributed resource on the grid (10). The site management system (11) provides signals representative of the present power capability (Kw Capacity—88) of each of the power plants (18), and a signal (Total Kw Capacity—95) representative of the total present power capability at the site. These power representations are used to appropriately assign power dispatch loadings to the respective [fuel cells] power plants (18) in the grid connected mode and in the grid independent mode, and may also be used for load shedding.

34 Claims, 3 Drawing Sheets

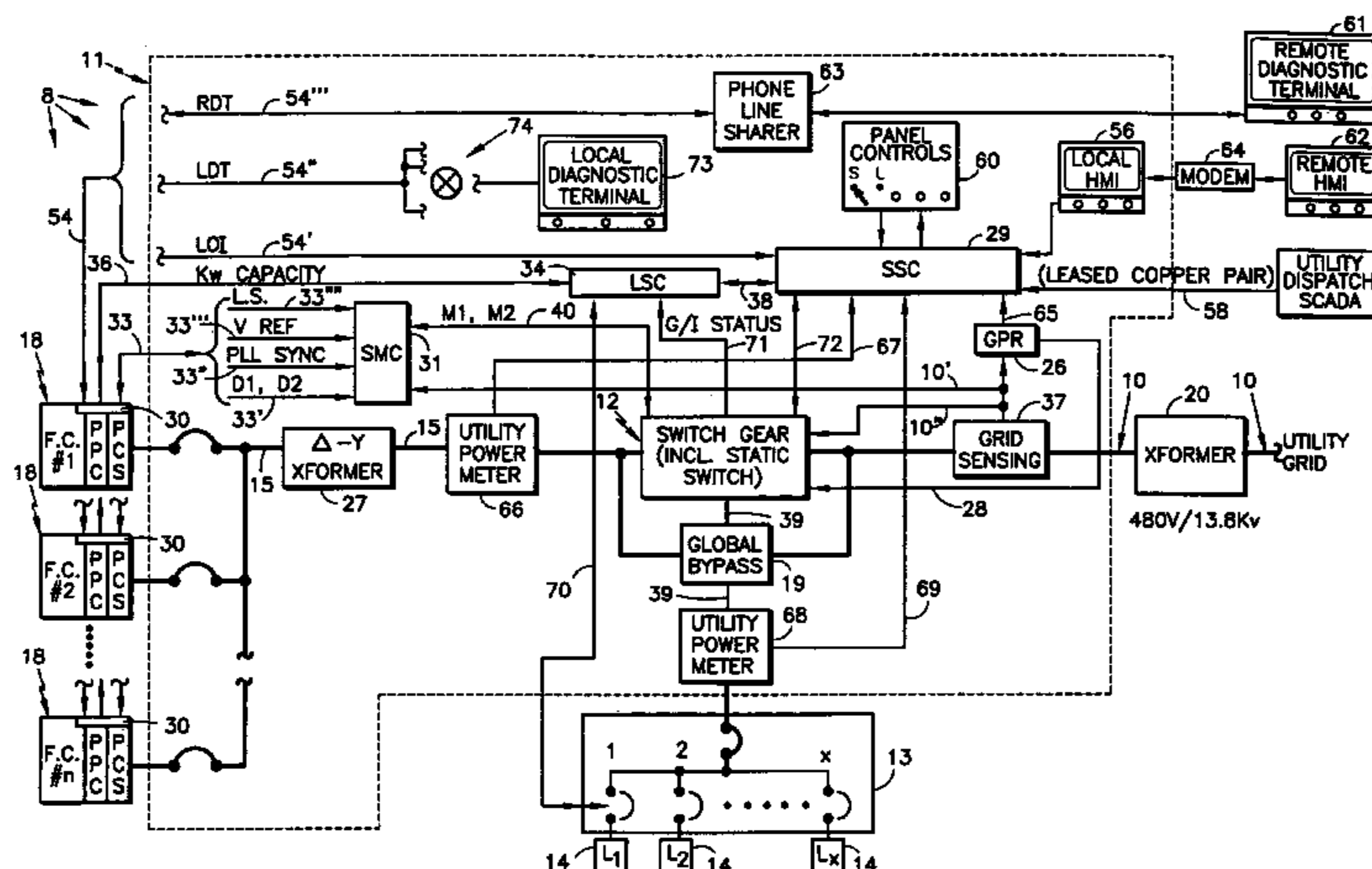

U.S. PATENT DOCUMENTS

5,750,278	A	5/1998	Gillett et al.	429/24
5,783,932	A *	7/1998	Namba et al.	322/16
5,798,939	A *	8/1998	Ochoa et al.	700/286
5,811,960	A *	9/1998	Van Sickle et al.	322/4
6,011,324	A *	1/2000	Kohlstruck et al.	307/64
6,134,124	A *	10/2000	Jungreis et al.	363/34
6,215,202	B1 *	4/2001	Luongo et al.	307/64
6,255,805	B1 *	7/2001	Papalia et al.	323/207
6,288,456	B1 *	9/2001	Cratty	307/64
6,304,006	B1 *	10/2001	Jungreis	307/64
6,384,580	B1 *	5/2002	Ochoa et al.	323/207
6,420,978	B1 *	7/2002	Shinada et al.	340/999
6,452,289	B1 *	9/2002	Lansberry et al.	307/25
6,465,910	B2 *	10/2002	Young et al.	307/64
6,503,649	B1 *	1/2003	Czajkowski et al.	429/23
6,510,369	B1	1/2003	Lacy	700/295
6,559,559	B2 *	5/2003	Cratty	307/64
6,602,627	B2 *	8/2003	Liu et al.	429/23
6,611,068	B2 *	8/2003	Cratty	307/64
6,697,951	B1 *	2/2004	Sinha et al.	713/300
6,882,904	B1 *	4/2005	Petrie et al.	700/295
6,925,361	B1 *	8/2005	Sinnock	700/286
2001/0001051	A1 *	5/2001	Cratty	429/12
2002/0014802	A1 *	2/2002	Cratty	307/43
2002/0135233	A1 *	9/2002	Cratty	307/64

OTHER PUBLICATIONS

Kornblit et al., "Installing a fuel cell on an existing power system", IEEE, 1993.*
 Carrasco et al., "Microcomputer control of a fuel cell power system", IEEE, 1994.*
 Nara et al., "An advanced flexible and reliable distribution system", IEEE, 1995.*
 Rajamani et al., "Islanding and load shedding schemes for captive power plants", IEEE, 1998.*
 Gilbert, Steve, "The Nations Largest Fuel Cell Project A 1 MW Fuel Cell Power Plant Deployed as a Distributed Generation Resource", Anchorage, Alaska, Aug. 9, 2000.*
 EG & G Services Parsons, Inc., "Fuel Cell Handbook", 5th edition, Oct. 2000.*
 "The Huber Mills digital power report, Powering the Telecom—Fuel Cells II: Big and Hot", Gilder Publishing, Sep. 2000.*
 Binder, "Site Management System for Multiple Fuel Cell System Operation", US Army Corps of Engineers, Oct. 2000.*
 Ditoro, "Fuel Cells: Improving the Bottom Line", HDR, Oct. 2000.*
 "Fuel Cells Prove Their Mettle, Provide Reliable Power", ACHRNEWS, Jan. 2001.*
 Holcomb et al., "Phosphoric Acid Fuel Cells", US Army Corp of Engineers, Dec. 2000.*

* cited by examiner

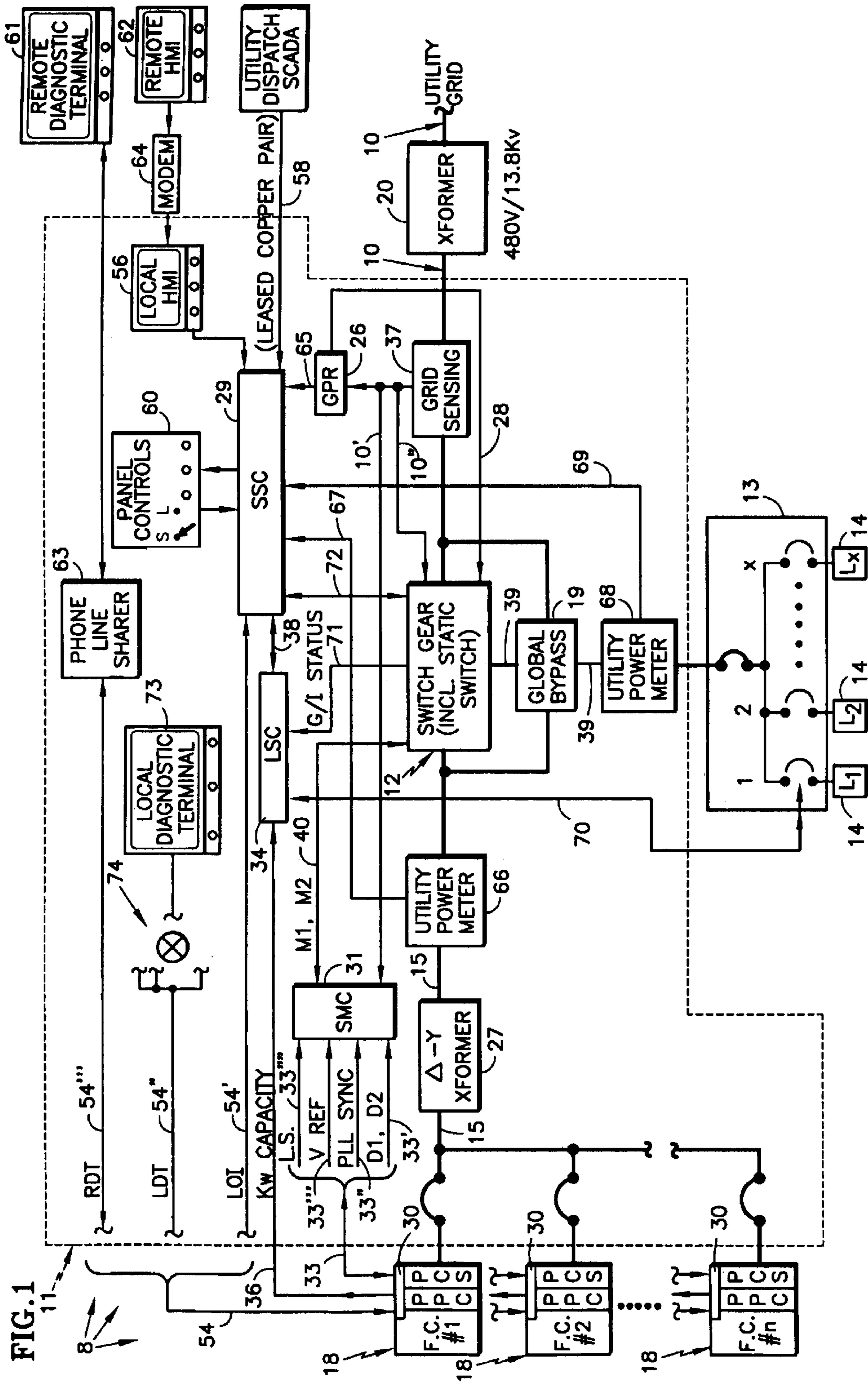

FIG. 1

FIG.2

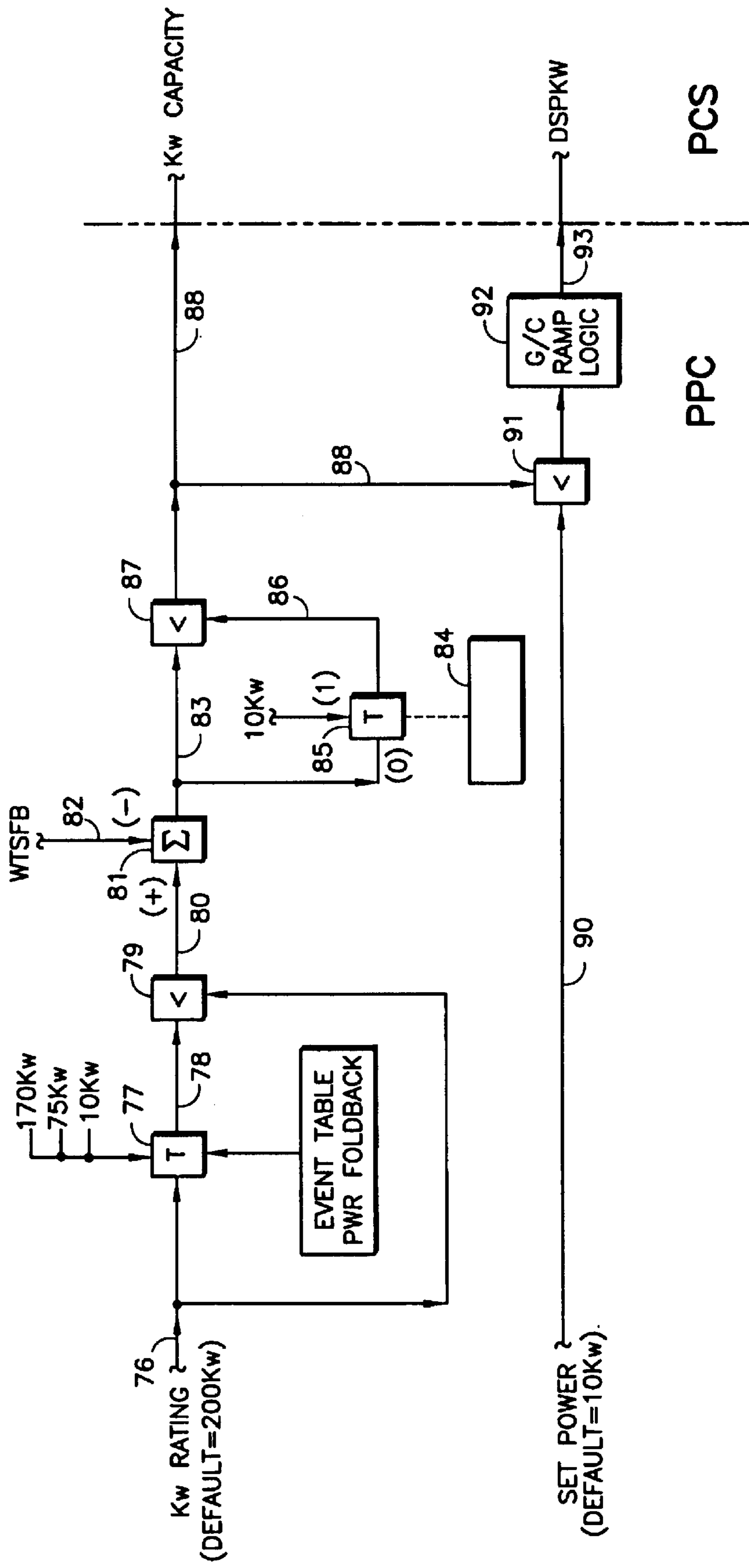
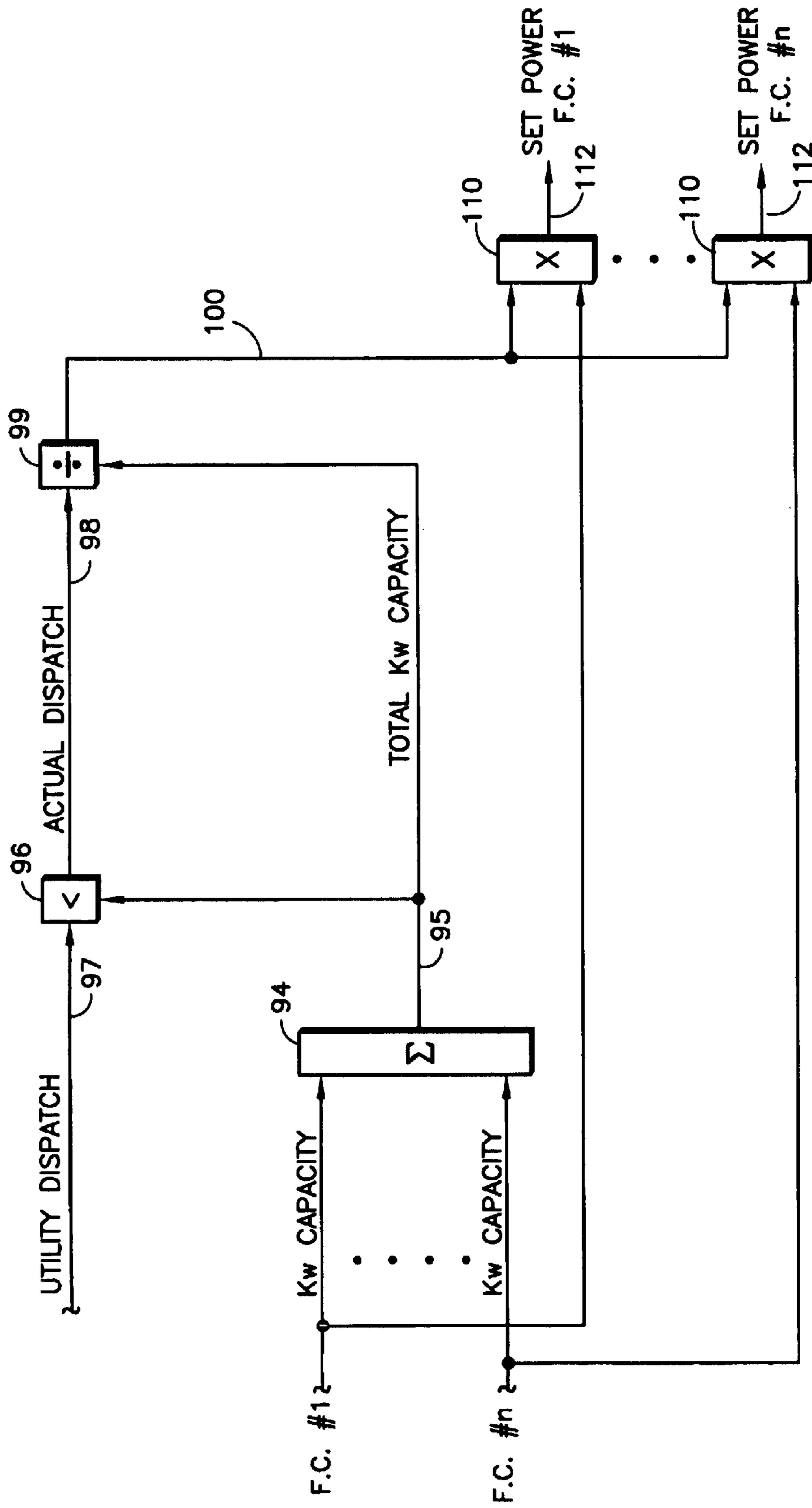

FIG. 3



**CONTROL OF MULTIPLE POWER PLANTS
AT A SITE TO PROVIDE A DISTRIBUTED
RESOURCE IN A UTILITY GRID**

Matter enclosed in heavy brackets [] appears in the original patent but forms no part of this reissue specification; matter printed in italics indicates the additions made by reissue.

CROSS-REFERENCE TO RELATED
APPLICATION

Reference is made here to related, patent application U.S. Ser. No. 09/782,402, filed Feb. 13, 2001 for System for Providing Assured Power for a Critical Load by the same inventive entities as herein and owned by the same assignee as herein, now U.S. Pat. No. 6,465,910 issued Oct. 15, 2002, which application/patent is incorporated herein by reference to the extent necessary, if at all, to provide essential and/or nonessential material.

TECHNICAL FIELD

This invention relates *generally to power systems and to the control of [fuel cell] power plants, and more particularly to the control of multiple [fuel cell] power plants at a site.* More particularly still, the invention relates to the control of multiple fuel cells at a site to provide a distributed resource in a utility grid.

BACKGROUND ART

Individual fuel cells have been used both experimentally and commercially in various configurations to power various electrical loads. In the main, the applications have relied on a single fuel cell, or fuel cell power plant, to supply electrical power to one or more loads at the site. While such sites may be mobile, as in the powering of the electric drive motor of a vehicle, in the main they are large and stationary. These applications have typically been individual commercial installations or buildings, perhaps involving computers or similar electronic data processing equipment or medical equipment requiring a reliable source of power.

To operate such fuel cell power plants, there are normally associated various controls for the direct control of the fuel cell itself and its production of DC electrical power, as well as additional controls for convening the DC power to AC power, for connecting and disconnecting power with the loads, etc. In some instances, the fuel cell power plant is connected to the loads in parallel with the normal electric utility grid, and may act in lieu of, or in addition to, the grid to supply power to the loads. In other instances, there may be multiple fuel cell power plants at a site, collectively connected to the loads in parallel with the utility grid. However, even in such configuration, the control of the fuel cells has typically been on an individual basis, with little or no provision for an integrated control arrangement to optimize the use of multiple fuel cell power plants interconnected with the utility grid and the loads.

When one or more fuel cell power plants are connected to the utility grid as well as the loads, they are said to be in a grid connected (G/C) configuration or mode. Alternatively, when those fuel cell power plants are connected only to the loads, they are said to be in grid independent (G/I) mode. In the G/I mode, the fuel cell power plants typically follow the load and apportion the load among the power plants. The transition from one such mode to the other, and the control of multiple fuel cell power plants relative to the loads present

additional control complexities that have impeded the efficient and economic utilization of multiple fuel cell power plants as distributed resources in electric utility grids.

Accordingly, it is an object of the invention to provide *a power system having* a control arrangement for the efficient and economic utilization of multiple [fuel cell] power plants, *e.g., fuel cells*, at a site as a distributed resource in a utility grid.

It is a further object of the invention to provide a control arrangement to optimize the interrelationship between multiple fuel cell power plants and multiple loads at a site in order to enhance utilization of the plants as a distributed resource in a utility grid.

It is a still further object to provide a control arrangement for a multiple fuel cell power plant generation system at a site that coordinates operation of the fuel cell power plants in an integrated, or unified, manner in both the G/C and the G/I modes of operation.

DISCLOSURE OF INVENTION

The present invention concerns the control of multiple [fuel cell] power plants *in a power system* at a site, particularly as a distributed resource for inclusion in a utility grid. The invention further concerns the unified, or integrated, control of multiple fuel cell power plants at a site, both in a grid connected (G/C) mode to facilitate their use as a distributed resource in a utility grid network and in a grid independent (G/I) mode to optimize their value and utility as an/the independent power supply to one, or typically multiple, customer loads at the site.

Accordingly the present invention relates to a fuel cell-powered generating system at a site for inclusion as a distributed generating resource in a distributed generation utility power grid, and comprises multiple fuel cell power plants at the site, at least one, and typically multiple, loads located substantially at the site, and a site management system operatively connected to the multiple fuel cell power plants, the one or more loads, and the utility grid for controlling the fuel cell power plants in an integrated, or unified manner, in, alternatively, a grid connected mode of operation having the fuel cell power plants connected to the load(s) and to the power grid, and a grid independent mode having the fuel cell power plants connected to the load(s) independent of connection to the power grid. This integrated control provided by the site management system allows the utility to view the multiple fuel cell power plants at the site as a single, or unified, distributed generating resource when connected to the grid. Accordingly, as used in this context, the terms "integrated" and "unified" are viewed as being substantially synonymous. Moreover, the integrated control facilitates the operation of the site in the G/I mode where the fuel cells are typically load-following and have operated independently of one another. In this latter regard, the integrated control in the G/I mode further facilitates a load management (sharing and shedding) capability for assuring power to critical loads.

The fuel cell power plants each include control and logic capabilities for folding back (reducing) rated power levels to lesser levels, if necessary, in response to various power plant conditions, and for providing signals representative of the instant power level capability of the respective plants. As used herein in association with power capacity and load demand, the term "instant" is intended to be synonymous with "present", "current", or "instantaneous". The site management system sums the individual power capacities of the respective fuel cell power plants and obtains a measure of the total instant power capacity of the multiple power plants

at the site. This measure of total power capacity and the respective individual power capacity measures are used to provide a site power measure to the utility grid and to appropriately load each of the power plants in G/C mode, and are used in the G/I mode to appropriately load each of the power plants to operate in a unified manner and further, for a load shedding function. In this latter regard and assuming multiple loads, the site management system is operative to recognize the instant load demand, the instant total power capacity, and a predetermined prioritization of the loads in the event load demand exceeds instant total power capacity, and to selectively shed or disconnect loads in accordance with the schedule, if necessary.

The site management system includes at least one, and typically several, signal processing logic controllers cooperatively interacting with one another, the multiple fuel cell power plants, and the utility grid to perform the integrated control functions of the invention.

The foregoing features and advantages of the present invention will become more apparent in light of the following detailed description of exemplary embodiments thereof as illustrated in the accompanying drawings.

BRIEF DESCRIPTION OF DRAWINGS

FIG. 1 is a simplified schematic block diagram of a power system, employing multiple fuel cell power plants at a site, as a distributed resource in a utility grid system and a backup power source to one or more loads located at the site when the grid is unavailable;

FIG. 2 is a generalized, functional schematic block diagram illustrating the development of a signal representative of the present power generating capacity of a respective fuel cell power plant; and

FIG. 3 is a generalized, functional schematic block diagram algorithmically illustrating the power dispatch loading of multiple fuel cell power plants when operating in the G/C mode.

BEST MODE FOR CARRYING OUT THE INVENTION

Referring to FIG. 1, there is depicted a simplified block diagram of a fuel cell-based power system **8** in accordance with the invention, which is readily available and utilized at a site as a distributed resource in a utility grid system. The power system **8** is connected to utility grid bus **10**, and employs multiple fuel cell power plants **18** located at a common site, for supplying, with the grid **10**, 3-phase power to, and through, load contactor array **13** to loads **14**, usually also at the same site. In the preferred and normal instance, the fuel cell power plants **18** provide power to the loads **14** on a substantially continuous basis, irrespective of occasional disconnects of the utility grid **10** from the power plants **18** and loads **14**. Switching gear, generally designated **12** and described below, includes a static switch that rapidly opens during utility grid disturbances to isolate the loads **14** and the fuel cell power plants **18** from the grid **10**, and the fuel cells provide substantially continuous power to the loads during these disturbances. For simplicity, a "single line" diagram, or representation is used herein to depict the 3-phase supply lines, as well as their included switches and other circuit components. Similarly, with respect to the control circuitry forming part of this invention, it will be understood that single-line representations have often been used for twisted pairs, or grouped parallel leads, which serve as signal conductors. For convenience of explanation and visual distinction, the portions of the schematic carrying the rela-

tively higher voltage/current/power to the loads **14** are bolded, in contrast with the lower-voltage, control portions of the system **8**.

The grid **10**, the fuel cell power plants **18**, and the loads **14** are interconnected and controlled through a Site Management System (SMS), represented by broken line block **11**. The loads **14**, here designated L_1, L_2, \dots, L_x , are those of the customer at the site, and typically include one or more "critical" loads, such as computers, electronic data processing devices, and/or medical devices, that require a substantially continuous supply of power. Others of those loads **14** may be less critical, being able to tolerate brief or longer-term power interruptions. In a typical contactor array **13**, there may be 12 individual, separately-controllable, contactors i.e., 1, 2, . . . X, with respective loads $L_1, L_2 \dots L_x$ connected to a terminal thereof. Selective actuation of the individual contactors may be used to selectively connect and disconnect the respective loads from the power sources, as will be described hereinafter.

The utility grid bus **10**, following step-down by transformer **20**, normally provides power at 480 Vac and 60 Hz, as also do the fuel cell power plants **18** via lead, or bus, **15**, through the delta-to-wye transformer **27**. Switching gear, **12** serves to interconnect the fuel cell power plants **18** through bus **15**, the loads **14** through a load power bus **39**, and the utility grid **10**. In this way, the fuel cell power plants **18** (or simply "fuel cells **18**" or "power plants **18**") are available and connected for supplying power on a full time basis to the loads **14** or to the loads **14** and utility grid **10**, for economical usage of the fuel cells. The switching gear **12** preferably includes a high current capacity, high speed, static (solid-state) switching arrangement and several inter-tie or breaker switches (not shown), as described in the aforementioned application U.S. Ser No. 09/782,402, now U.S. Pat. No. 6,465,910. The static switch, which may be pairs of counter-connected, silicon controlled rectifiers, serves as the main operational switch, and is closed during normal operation of the grid **10**, to connect the grid **10** with the power plants **18** and loads **14**, and is open if the grid goes out of limits or if an "enable" signal is removed. The breaker switches are typically electromechanical and may be automatically or manually actuated to selectively provide bypass paths around the static switch and/or to open otherwise closed paths. Global bypass breakers **19** connected to busses **15**, **10** and **39**, serve, when manually closed, to further bypass the switching gear **12**, as during maintenance or a start-up or shutting down operation.

There are multiple fuel cell power plants **18** at the site, and it is the integrated control of and/or involving, those multiple power plants **18** which comprises the present invention. In an exemplary arrangement, five (5) such power plants **18** are located at the site and controlled by the SMS **11**. Each power plant **18** is a 200 kw International Fuel Cells, LLC (formerly ONSI) PC25™ power plant, with the five units collectively being capable of providing up to 1 megawatt of power. Each such power plant **18** includes the basic fuel cell (F.C.), a Power Plant Controller (PPC), and a Power Conditioning System (PCS) which includes its own separate controller. The fuel cell, F.C., includes (not shown) a fuel stack assembly, ancillary fuel processing and delivery equipment, oxidant delivery equipment, and a water and steam management system, as is generally well known. The PPC includes the controls, logic and monitoring equipment directly associated with the operation and control of the respective F.C., as generally known, and including additional provision for evaluating the present power generating capability of the power plant **18**, as will be described. The PCS contains a

5

solid-state inverter and its controller which converts DC power to AC power at the desired voltage and frequency. Control of and by the PCS, as through its associated controller and the other controllers to be hereinafter discussed, further enables conversion of the mode of operation of a power plant **18** from G/C to G/I, and vice versa, as is generally known and will be better understood by reference to the aforementioned application U.S. Ser. No. 09/782,402, now U.S. Pat. No. 6,465,910. When used in G/C mode, the variable controlled by the PCS is power delivered (both real and reactive). When used in the G/I mode, the variables controlled are output voltage and frequency, and, if multiple power plants **18** are involved, phase. The output voltage of a three-phase system is, of course, controlled to be at a phase angle of 120° between each phase. The outputs of the several fuel cell power plants **18** are collectively joined by bus **15**. Control signals may be exchanged between the several component portions of a power plant **18**, i.e., the F.C, PPC, and PCS, via one or more signal paths, here collectively depicted for convenience as a common signal bus and I/O port **30**.

In addition to the switching gear **12**, the SMS **11** for the site includes three controllers which are responsible for coordinating integrated operation of the multiple power plants **18**, first with respect to each other and with respect to the customer loads **14**, and ultimately as a single power resource with respect to the utility grid.

A Site Management Controller (SMC) **31** provides direct control of the PCSs of the fuel cells **18** in response to mode indicating/controlling signals M1 and M2 Image Page 4 on lead **40** from logic associated with the static switch of switching gear **12**, and further in response to a grid voltage reference signal **10'** provided by grid sensing circuitry **37**. The grid sensing circuitry **37** typically includes a potential transformer (sensor) and a current transformer (sensor) to sense the voltage and current of grid **10** and provide respective signals thereof. The mode signals M1 and M2 from switching gear **12** are indicative of switching of the static switch, and thus the need for a mode change from G/C to G/I, or vice versa. Logic associated with the static switch receives a signal via lead **10''** from the grid sensing circuitry **37** and determines whether the grid is within limits or not. A change in this condition acts through the logic to “toggle” the static switch, as described in the aforementioned application U.S. Ser. No. 09/782,402, now U.S. Pat. No. 6,465,910, and to signal such action via the M1 and M2 signals on lead **40**. The SMC **31** also includes provision for issuing load share control signals to each of the PCSs of the respective fuel cells **18**, to apportion the load among the fuel cells **18** during load following operation in the G/I mode. That load sharing typically takes into account the present power generating capacity of each fuel cell **18**, as provided by status signals from the fuel cell power plants **18**, and apportions the load accordingly amongst them.

The SMC **31** is typically composed of computers, programmable logic, sensors, and control circuitry. The combination of the mode signals M1 and M2, and the information about grid voltage, phase and frequency provided on lead **10'**, serve in the SMC **31** to provide, as outputs, further mode control signals D1 and D2 on lead **33'**, a phase lock loop sync signal on lead **33''**, and a voltage reference signal on lead **33'''**. A signal bus **33** exchanges these control signals between the SMC **31** and the PCSs of the several power plants **18**. The signal bus **33** also conveys, between the SMC **31** and each of the PCSs, the several load share status and control signals collectively represented as lead **33''''** to/from the SMC **31**. These signals are used to apportion the load among the fuel cells **18** during load-following operation in

6

the G/I mode. The “load sharing” algorithm takes into account the present power generating capacity of each fuel cell **18**, as provided by status signals from the fuel cell power plants **18**, and apportions the load accordingly amongst them.

The grid **10** voltage and current signals sensed by the grid sensing circuit **37** are also extended to a grid protection relay **26**, which in turn is responsive to the grid voltage and current being in or out of limits to provide a control signal on lead **28**. The lead **28** is connected to the switching gear **12**, and the signal thereon serves to control one or more breaker switches in a manner to assure the load continues to have power during grid disturbances and also to protect the static switch, the grid **10**, the power plants **18** and/or the loads **14** in the event of extreme conditions.

A second controller is the Load Shed Controller (LSC) **34**, which is a programmable logic control comprised of appropriate standard integrated circuits. The LSC **34** provides high-speed load shed control in the G/I mode, as will be described below. The LSC **34** receives respective kilowatt (Kw) capacity signals from each of the power plants **18** (1 through n) via a signal bus **36**, here collectively representative of all “n” of the signals. The respective Kw capacity signals are typically developed in the respective PPCs of each power plant **18**, pass through the respective PCSs, and each extend to the LSC **34** via I.O. port **30** as a 4–20 ma signal via respective pairs, here collectively represented as lead **36**. The development of the Kw capacity signals at the PPCs, and their eventual use in the various controls of the SMS **11**, will be described below in greater detail. Suffice it to say at this juncture that the Kw capacity signals are a measure of the power generating capacity of the individual power plants **18**, and find use in load sharing, load shedding, and in the overall control of the multiple power plants **18** as a unified, or singular, resource in a utility grid of distributed resources. Further, 2X signals (possibly 24 in number) are communicated between the LSC **34** and the X (possibly 12 in number) contactors 1 through X of the contactor array **13** via discrete signal lines, here represented for simplicity as a single lead **70**. Half of these signals are representative of the status of the respective contactors, and the other half are responsible for controlling the opening or closing of the respective contactors. The LSC **34** also receives an indication, via lead **71** from the logic associated with the static switch of switching gear **12**, of the mode status, and particularly entry into the G/I mode. This enables operativeness of the load shedding function in that mode, and vice versa.

The third controller is the Site Supervisory Controller (SSC) **29**, which provides the operator interface for the power system **8**, is responsible for integrated supervisory control of the system at a high level, and provides an interface between the customer (or operator) at the site and the utility. As with the LSC **34**, the SSC **29** is a programmable logic control comprised of appropriate standard integrated circuits programmed to perform the required functions. A bus extender **38** connects the LSC **34** and the SSU **29** such that the two may be viewed collectively as a unit. The SSC **29** includes six interfaces with the remainder of the power system **8**, as well as with the utility grid.

One of those interfaces is the interconnection of the LSC **34** with the SSC **29** via the bus extender **38**. The LSC **34** communicates the 2X number of signals associated with contactor array **13** to the SSC **29** approximately every half second such that the SSC **29** has override capability of the customer load contactors **13** as well as monitoring the customer load status, when in G/I mode.

Another interface involves the communications between the SSC 29 and the individual power plants 18 via n pairs of Local Operator Interface (LOI) leads 54', only one being shown connected to the SSC 29, and the connection with the PPCs of the power plants 18 being represented, for simplicity, as but part of a cumulative, multiple path, diverse signal communication bus 54. These signals include those necessary for the routine supervisory control of the power plants 18, and are used to obtain data from the power plants 18 for both local display on the Local Human Machine Interface (HMI) 56 and for use at the utility dispatch Supervisory Control and Data Acquisition (SCADA) interface on lead 58 from/to the utility. A panel control 60 includes manual controls for various annunciators and, particularly, a mode switch input providing selection between a local operating mode (L) in which the power plants 18 are controlled individually, and a supervisory mode (S) in which the several power plants are operated as a unit. When the mode selector switch from panel control 60 is in the supervisory mode (S), as depicted in FIG. 1, both the Local HMI 56 and a Remote HMI 62 are inhibited from issuing control or dispatch commands. Then, all control and dispatch signals come from the utility's remote dispatch station (not shown) via the SCADA interface line 58, which is a Modbus remote terminal link comprised of a leased (dedicated) copper pair. The Remote HMI 62 is connected with a remote site, such as the power plant 18 manufacturer and/or the utility, by phone line through a local modem 64, and conducts data and control commands from and to the Power Plants 18 via leads 54 and 54'" only when the mode selector switch is in the local mode. The Local HMI 56 conducts data and control commands from and to the power plants 18 via leads 54 and 54', with the interaction of the SSC 29, only when the mode selector switch is in the local mode (L). The connection between the local HMI 56 and the SSC 29 represents a third interface with the SSC 29. Similarly, the Remote HMI 62 is connected with a remote site, such as the power plant 18 manufacturer and/or the utility, as by a phone line through a local modem 64, and conducts data and control commands to and from the power plants 18 via the Local HMI 56, the SSC 29, and the leads 54 and 54' only when the mode selector switch is in the local mode (L).

A fourth interface with SSC 29 involves the grid protection relay 26 via lead 65. This connection reports the status of grid 10, and any faults or out of limit conditions therewith, such as current, voltage, phase or frequency abnormalities, as discerned by grid sensing unit 37 and applied through the GPR 26.

A fifth interface with the SSC 29 involves the provision of signals indicative of the power delivery by the several power plants 18, by means of a utility power meter 66 connected to power bus 15 and having a signal lead 67 connected to SSC 29, and indicative of the power delivered to/drawn by the loads 14, by means of a utility power meter 68 connected to load power bus 39. The power meter 68 is connected to bus 39 intermediate the contactors 13 and the global bypass 19, and has a signal lead 69 connected to SSC 29. The power meters 66 and 68 each typically include a potential (voltage) sensor and a current sensor (neither shown) for cumulatively determining power. These power readings are used by the SSC 29 and the LSC 34 for control actions to be hereinafter explained.

The sixth interface involves 2-way communication between the SSC 29 and the switching gear 12, as represented by the lead 72. The SSC 29 may provide discrete signals to the static switch control and to selected breaker switches to allow it to select the operating mode of the SMS

11 if necessary. Similarly, those switches return respective status signals to the SSC 29. The SSC 29 may provide an "enable" signal to the static switch, and when present allows the switch to operate autonomously based on the condition of grid 10 at the time. When the signal is "disabled", it forces the static switch to open and cause power system 8 to operate in the G/I mode.

A local diagnostic terminal 73 is connected selectively through an "n-way" switch 74 and leads 54" and 54, to the individual ones of the n-number of power plants 18 for obtaining diagnostic data. Also included is a remote diagnostic terminal (RDT) 61 connected through an "n-way" phone line sharer 63 to the individual n-number of power plants 18, via leads 54 and 54'", for similarly obtaining diagnostic data.

Reference is now made to FIG. 2, which depicts a generalized functional schematic block diagram of the development, in the PPC of a respective power plant 18, of a Kw capacity signal (Kw Capacity) indicative of the present power generating capacity of the respective fuel cell power plant 18. This signal is then used, both on an individual plant basis and on a cumulative power system 8 basis, to enable and facilitate remote dispatch of power requirements by the utility in the G/C mode, as well as load sharing and load shedding capabilities in the G/I mode. A Kw rating value (KwRATING) is initially assigned to a respective fuel cell power plant 18, as represented on input lead 76 to an Event Table 77. The KwRATING signal has a normal default value of 200 Kw, which assumes the fuel cell and plant are operating, or operable, at full capacity. This value may be adjusted by an operator or the manufacturer to reflect a lesser value in view of predetermined circumstances which may degrade performance of the plant by a prescribed amount. The Event Table 77 contains several power foldback values, each of which correspond with one or more "abnormal" conditions in the operation of the fuel cell F.C. portion of the power plant 18. For instance, for conditions of low steam to fuel ratio in the fuel cell system, the power rating may be folded back to 170 Kw, and for conditions such as inability to satisfy fuel demand, insufficient make-up water, excessive fuel cell cabinet temperature, etc., the foldback may be greater, to a Kw rating of only 75 Kw. These foldback power values (and others) are depicted on the scale appearing at the top of table 77, whereas in fact the table serves to correlate a sensed condition with a predetermined foldback power rating and provide as an output, a signal on lead 78 which is representative of a folded back power rating. This signal is applied to a lesser select function 79, which has as its other input the initial KwRATING value from lead 76. The lesser power value of the signals on leads 76 and 78 is then provided as the output on lead 80. A further possible power foldback may be made at the summer 81, which receives a (+) input from lead 80 and may receive a (-) input on lead 82. The lead 82 contains any power foldback magnitude resulting from a sensed abnormality in the water treatment system for the fuel cell, and that foldback magnitude is variable and may range from a power decrease of as little as 0 Kw to as much as 190 Kw. In this instance, the value appearing on lead 80 will be reduced by the value appearing on the lead 82, to provide a resultant output on lead 83. The value on lead 83 may also, or further, be folded back, or overridden if the fuel cell water treatment system is placed in a maintenance mode. This potential override results when a water treatment maintenance mode signal 84 is applied to a Table 85, which Table is scheduled to provide, as an output on lead 86, either the value on lead 83 if the water treatment is operating normally or a preset folded back value of only 10 Kw if

the mode signal on **84** indicates the maintenance mode. The value on lead **86** is compared with that on lead **83** at the lesser select function **87**, and the lesser value is then provided as the Kw Capacity signal on lead **88**. Thus it will be realized that under normal operating circumstances and conditions, the Kw Capacity signal may be as large as 200 Kw; whereas if one or more of the other conditions arise or exist, the rating will be folded back to a value between 200 kw and 10 kw, accordingly. This, then, represents the power generating capacity of that power plant **18** at that moment. The various contributing parameters are monitored at least as frequently as 0.5 sec. such that the Kw Capacity signal may be updated and sent every 0.5 seconds.

Referring further to FIG. 2, a Set Power value (designated **112** in FIG. 3 below) is applied to lead **90**, and is the result, for a single power plant, of the total power dispatch signal (designated **97** in FIG. 3 below). The total dispatch is apportioned among the multiple power plants in accordance with the algorithm to be described with respect to FIG. 3, and the resulting Set Power is indicative of a desired or commanded level of power output from the respective single ones of the power plants **18**. This total dispatch value may be set by the utility via the SCADA input **58** to SSC **29**, and is conditioned by the algorithm depicted in FIG. 3 to provide the resultant Set Power value. This Set Power value on lead **90** is compared with the Kw Capacity value on lead **88** at lesser select function **91**, and the lesser of the two is then available as the control signal DISPKW to command the level of power to be dispatched by that power plant **18**. The output of lesser select **91** may be extended through GIC ramp logic **92**, such that the DISPKW signal on lead **93** will change levels at a predetermined rate so as to insure relatively smooth power transitions, particularly when transitioning between G/C and G/I modes. Each Kw Capacity signal is passed through the PCS of a power plant and, from a current transducer in the PCS, is passed to LSC **34** via lead **36**. Each DISPKW signal on a lead **93** represents a command signal sent from a respective PPC to a respective PCS for regulating the Kw power output of the respective power plant **18**.

Referring to FIG. 3, there is a generalized functional schematic block diagram of logic, typically in the SSC **29**, that determines the power dispatch loading of the multiple (1 through n) power plants **18** when operating in the G/C mode. The Kw Capacity signals for/from each of the n fuel cell power plants **18** are cumulatively applied as inputs to a summer **94** to provide a Total Kw Capacity signal as the output on lead **95**. This signal represents the total power generating capacity of the power system **8** at that moment. The Total Kw capacity signal is provided as one input to a lesser select function **96**, with another input being a UTILITY DISPATCH signal on lead **97**. The UTILITY DISPATCH signal may be derived from a demand signal received from the utility via SCADA line **58**. The output of the lesser select **96** appears on line **98**, and is thus the ACTUAL DISPATCH value. In other words, the actual dispatch value is the lesser of those two input values, and can never be more than the Total Kw Capacity. The ACTUAL DISPATCH value is then ratioed with, or divided by, the Total Kw Capacity value in the division function block **99** to provide an output value represented on lead **100**. In the event the UTILITY DISPATCH value is equal to or greater than the Total Kw Capacity value, the output **100** will be unity (one), whereas if the UTILITY DISPATCH request is less, then the output **100** will have some fractional value less than one. This value on line **100** may be deemed a weighting, or pro rating, factor. It is applied as an input to each of n multiplier function blocks **110**, which function blocks have the Kw Capacity value for

that respective power plant as their other input. The products of these multiplication functions are the respective SET POWER signal values appearing as outputs on lines **112**, and used as the SET POWER value on line **90** in FIG. 2. In this way, the SET POWER demand signal for each power plant **18** (1 through n), is the ratioed amount of that plant's Kw capacity, and can never be greater than its capacity. In the instances when the UTILITY DISPATCH value is equal to or greater than the Total Kw Capacity, each plant will be loaded to its present maximum capacity. Conversely, if the ratio is less than unity, each plant will be loaded to that ratioed amount of its present capacity.

An alternative to the algorithm depicted with respect to FIG. 3 is one which initially assumes that all power plants have equal capacity and thus, divides the UTILITY DISPATCH request value by the number of fuel cell power plants (n) to obtain an initial "per power plant" dispatch value. The relevant logic then compares the Kw Capacity signal for the first power plant **18** (#1) with the initial "per power plant" dispatch value and, if sufficient capacity exists, the requested value is put in that power plant's power dispatch register. The same is done for the remaining fuel cell power plants (#2 through n). If a particular fuel cell power plant **18** is limited and can not supply the full requested "per power plant" dispatch value, then it is loaded to its power-limited capacity and the remainder is stored in an overflow register or the like. When all fuel cells **18** have been polled and loaded based on their respective kilowatt generating capacities, then the Kw amount accumulated and stored in the overflow register is distributed amongst the fuel cells **18** with remaining, or extra, power generating capacity, using the same logic as described above. This process continues iteratively until either the entire dispatch request has been assigned to the power plants **18** or no additional capacity remains for the overflow dispatch request. If the latter occurs, an alarm message is sent to the utility's dispatch center via line **58**, stating that the power request exceeds the current generating capacity of the site.

During operation of the site-based power system **8** in the G/C mode, not only is the total capacity of the n fuel cell power plants **18** available to supply the demands of the local customer loads **14**, but the nominally "infinite" resource of the utility grid **10** is also available. However, when operating in the G/I mode, the maximum power available is that represented by the Total Kw Capacity value **95** depicted in FIG. 3. In such instance, if the actual total power demand of the collective loads **14** (L_1, L_2, \dots, L_x) is greater than the Total Kw Capacity value, as because the latter is reduced because of power "foldbacks" at the power plants **18**, some administrative action must be taken. According to an aspect of the invention, the customer loads **14** are arranged, or identified, according to a schedule of priorities. In the most refined instance, each of the total X number of loads has its own different relative priority. Alternatively, the loads **14** may be grouped, as for instance in high, medium, and low priority groups.

Then, in one embodiment, the total power demand of the loads **14**, as indicated by the signal **69** from Utility Power Meter **68**, is conveyed to SSC **29** where it is compared with the Total Kw Capacity signal **95** (of FIG. 3) to determine whether or not there is sufficient capacity to meet the instant demand of the loads. If there is, then that demand is met according to the established system load-sharing algorithm in SMC **31**. However, if that comparison, by subtraction or ratio or other convenient means, indicates that the instant load demand is greater than the Total Kw Capacity, a load shedding condition arises. This is done in accordance with

the previously determined schedule of priorities, by disconnecting (shedding) certain ones, or groups, of the loads **14** (L_1, L_2, \dots, L_x) by selective actuation (opening) of the respective individual load contactors **13** (1, 2, . . . X) by the control signals represented by lead **70** between the LSC **34** and the contactors **13**. The LSC **34**, in conjunction with SSC **29**, will then use the load priority schedule to actuate (open) those contactors **13** required to disconnect the lower priority loads and retain connected the more critical, higher priority loads. In one configuration, the loads can be shed sequentially by priority through an iterative process until the demand can be met by the Total Kw Capacity. In another, more sophisticated, arrangement, the instant demand of the load associated with each separate contactor **13** (1, 2, . . . X) might be determined by associating power meters with each contactor and using the information to compute, according to the priority schedule, which loads to disconnect in a single disconnection action. Of course, with either configuration, because the usage pattern of the loads **14** may be constantly changing as loads are “turned on and off” by the user, it is necessary to continually repeat this analysis and control action in the G/I mode to avoid overloading. When a power foldback condition is removed and/or certain higher priority loads are removed or “turned off”, some or all of the lower priority loads previously shed may be reconnected to the load power line **39**. In this way, the most critical customer loads always have power.

Although the invention has been described and illustrated with respect to the exemplary embodiments thereof, it should be understood by those skilled in the art that the foregoing and various other changes, omissions and additions may be made without departing the spirit and scope of the invention. For instance, the logic functions depicted in FIGS. **2** and **3**, as well as the many other logic functions performed by the invention, may be done with dedicated logic or via programmable logic circuitry, with the latter in the extreme instance being performed via one or more appropriately programmed computers.

What is claimed is:

1. A fuel cell-powered generating system (**8**) at a site for inclusion as a distributed generating resource in a distributed generation utility power grid (**10**), comprising:

- a. multiple fuel cell power plants (18_{1-n}) at the site;
- b. at least one electrical load (14_{L1-Lx}) located substantially at the site; and
- c. a site management system (**11**) operatively connected in each of the multiple fuel cell power plants (18_{1-n}), the at least one load (**14**), and the utility power grid (**10**) for issuing command signals for controlling multiple control functions of the power generating system in an integrated manner, including controlling the multiple fuel cell power plants (18_{1-n}) and the at least one load (14_{L1-Lx}) in an integrated manner, with respect to each other and with respect to the at least one load, in, alternatively:
 - i. a grid connected mode of operation having the fuel cell power plants (**18**) directly connected to the at least one load (14_{L1-Lx}) and to the utility power grid (**10**), and
 - ii. a grid independent mode of operation having the fuel cell power plants (**18**) directly connected to the at least one load (14_{L1-Lx}) independent of connection to the utility power grid (**10**); wherein the site management system is configured to control a transition of each fuel cell power plant from operation in one of the grid connect and grid independent modes, to operation in the other.

2. The fuel cell-powered generating system (**8**) of claim **1** wherein each fuel cell power plant (**18**) includes a fuel cell and associated sub-systems (F. C.) for generating power, a power plant controller (PPC) for controlling and monitoring [the] a condition of the fuel cell and support sub-systems (F. C.), and a power conditioning system (PCS) for conditioning the power provided by the fuel cell to the at least one load[s] (14_{L1-Lx}), the power plant controller (PPC) further including signal processing logic (**77, 79, 81, 85, 87**) responsive to signals indicative of the monitored condition of the fuel cell and support sub-systems (F. C.) for providing a signal (Kw Capacity—**88**) representative of the instant power output capacity of the respective fuel cell power plant (**18**), and wherein the site management system (**11, 94**) is responsive to the instant power output capacity signals (Kw capacity—**88**) from each of the fuel cell power plants (18_{1-n}) for providing a signal (Total Kw Capacity—**95**) representative of the total instant power output capacity of the multiple fuel cell power plants (18_{1-n}).

3. The fuel cell-powered generating system (**8**) of claim **2**, further including a received utility dispatch signal (**58, 97**) [received from the utility], and wherein the site management system (**11**) includes signal processing means (**96, 97, 110**) responsive to the received utility dispatch signal (**58, 97**) and the Total Kw Capacity signal (**95**) for selecting the lesser thereof to provide an Actual Dispatch signal (**98**) and for comparing the Actual Dispatch signal (**98**) with the Total Kw Capacity signal (**95**) to provide a pro-rated dispatch signal (**100**), and responsive to the pro-rated dispatch signal (**100**) and to the Kw Capacity signals (**88**) from each of the respective fuel cell power plants (**18**) to provide respective Set Power control signals (**112, 90**) for controlling [the] dispatch power for each respective fuel cell power plant (18_{1-n}).

4. The fuel cell-powered generating system (**8**) of claim **3** wherein the signal processing means (**96, 97, 110**) of the site management system (**11**) determines [the] a mathematical product of the pro-rated dispatch signal (**100**) and each of the Kw Capacity signals (**88**) from each of the respective fuel cell power plants (**18**), to provide each of the respective Set Power Control signals (**112, 90**).

5. The fuel cell-powered generating system (**8**) of claim **1**, further including a received utility dispatch signal (**58, 97**) [received from the utility], each fuel cell power plant (**18**) including a fuel cell and associated sub-systems (F. C.) for generating power, a power plant controller (PPC) for controlling and monitoring [the] a condition of the fuel cell and support sub-systems (F. C.), and a power conditioning system (PCS) for conditioning the power provided by the fuel cells to the loads, the power plant controller (PPC) further including signal processing logic (**77, 79, 81, 85, 87**) responsive to [the] signals indicative of the monitored condition of the fuel cell and support sub-systems (F. C.) for providing a signal (Kw Capacity—**88**) representative of the instant power output capacity of the respective fuel cell power plant (**18**), and wherein the site management system (**11**) includes signal processing means for dividing the received utility dispatch signal (**58, 97**) by the multiple number of fuel cell power plants (**18**) to provide an initial per power plant dispatch signal value, for comparing the Kw Capacity signal (**88**) for an initial fuel cell power plant (**18**) with the per power plant dispatch signal value and assigning to that plant as much of the per power plant dispatch signal value as allowed by the respective Kw Capacity signal (**88**), for storing any remainder value in overflow storage, for similarly comparing and assigning to each successive one of the multiple fuel cell power plants (**18**) as much of the per power plant dispatch signal value as allowed by the respective Kw

13

Capacity signal (88) and storing any respective remainder value, and for iteratively repeating the foregoing functions to allocate any remainder value remaining in the overflow storage.

6. The fuel cell-powered generating system (8) of claim 2, wherein *at least one of the at least one load* (14_{L1-Lx}) is connected (13) to receive power and the site management system (11) includes a power monitor (68) for providing a signal (69) representative of the total power demand of the *at least one connected load*[s] (14_{L1-Lx}), and further signal processing logic (34, 29) for comparing the total power demand signal (69) and the Total Kw Capacity signal (95) and, if and to the extent the total power demand exceeds the total Kw Capacity, shedding [one or more] *at least one connected loads* [14_{L1-Lx}] in accordance with a predetermined schedule.

7. The fuel cell-powered generating system (8) of claim 6, wherein each [of the multiple] *at least one connected load*[s] (14_{L1-Lx}) is connected to the fuel cell power plants (18) through respective selectively controlled contactors (13_{L1-Lx}), and wherein said shedding of *the at least one* [or more] of the *connected load*[s] is effected by selectively opening respective ones of the contactors (13_{L1-Lx}).

8. The fuel cell-powered generating system (8) of claim 1, wherein the site management system (11) is connected to receive dispatch signals from and provide status signals to, [the] *a remote utility* via communications linkage (58, 62, 64, 61) [connected between the site management system (11) and the utility].

9. The fuel cell-powered generating system (8) of claim 8, wherein the site management system includes a site supervisory controller (29) for effecting the integrated control of the multiple fuel cell power plants (18) and providing [the] control interface with the *remote utility*.

10. The fuel cell-powered generating system (8) of claim 9, wherein the site management system (11) includes a means (60) operatively connected with the site supervisory controller (29) for manually selecting operation of the generating system (8) either in a local operating mode in which the multiple power plants (18) are controlled individually or in a supervisory operating mode in which the multiple power plants (18) are operated in a unified manner.

11. The fuel cell-powered generating system (8) of claim 1, wherein the site management system (11) comprises a site supervisory controller (29) for effecting the integrated control of the multiple fuel cell power plants (18), a load shed controller (34) connected (38, 70) to interact with the site supervisory controller (29) and the *at least one load*[s] (14_{L1-Lx} , 13) to control load shedding, and a site management controller (31) connected to each of the fuel cell power plants (18) for controlling the power provided by the power plants (18) to the *at least one load*[s] (14_{L1-Lx}).

12. The fuel cell-powered generating system (8) of claim 2, wherein the site management system (11) comprises a site supervisory controller (29) for establishing, in response to a *received utility* power dispatch signal [from the utility], [the] power dispatch loading of the fuel cell power plants (18) in an integrated manner when operating in the grid connected mode, a load shed controller (34) connected (38, 70) to interact with the site supervisory controller (29) and the *at least one load*[s] (14_{L1-Lx} , 13), and a site management controller (31) connected to the PCSs of each of the respective fuel cell power plants (18) for controlling the transition of each fuel cell power plant (18) from operation in one of the grid connected and the grid independent modes, to operation in the other.

13. The fuel cell-powered generating system (8) of claim 12, wherein said site management system (11) further

14

includes high speed, static switching means (12) connected to the utility *power* grid (10), the fuel cell power plants (18, 15), and the *at least one load*[s] (14_{L1-Lx} , 13, 39) for rapidly disconnecting the *at least one load*[s] (14_{L1-Lx}) and the fuel cell power plants (18) from the utility *power* grid (10) and transitioning from the grid connected mode of operation to the grid independent mode of operation.

14. The fuel cell-powered generating system (8) of claim 2, wherein initial power rating signals (Kw Rating—76) representative of a base power capacity are provided for each of the multiple fuel cell power plants (18_{1-n}), and the signal processing logic (77, 79) is responsive to the monitored condition of each of the respective fuel cells and support sub-systems (F. C._{1-n}) to foldback the base power capacity (Kw Rating—76) of the respective power plant (18) by an amount predetermined in accordance with the monitored condition to thereby provide the respective instant power output capacity signal value (Kw Capacity—88).

[15. A fuel cell-powered generating system (8) at a site for inclusion as a distributed generating resource in a distributed generation utility power grid (10), comprising:

- a. multiple fuel cell power plants (18_{1-n}) at the site;
- b. at least one electrical load (14) located substantially at the site;
- c. a site management system (11) operatively connected to each of the multiple fuel cell power plants (18), the at least one load (14), and the utility grid (10) for controlling the multiple fuel cell power plants (18_{1-n}) in an integrated manner, in, alternatively:
 - i. a grid connected mode of operation having the fuel cell power plants (18) connected to the at least one load (14) and to the power grid (10), and
 - ii. a grid independent mode of operation having the fuel cell power plants (18) connected to the at least one load (14) independent of connection to the power grid (10), and wherein each fuel cell power plant (18) includes a fuel cell and associated sub-systems (F. C.) for generating power, a power plant controller (PPC) for controlling and monitoring the condition of the fuel cell and support sub-systems (F. C.), and a power conditioning system (PCS) for conditioning the power provided by the fuel cell to the loads, the power plant controller (PPC) further including signal processing logic (77, 79, 81, 85, 87) responsive to signals indicative of the monitored condition of the fuel cell and support sub-systems (F. C.) for providing a signal (Kw Capacity—88) representative of the instant power output capacity of the respective fuel cell power plant (18).]

[16. The fuel cell-powered generating system (8) of claim 15, wherein said site management system (11) further includes high speed, static switching means (12) connected to the utility grid (10), the fuel cell power plants (18, 15), and the loads (14, 13, 39) for rapidly disconnecting the loads (14) and the fuel cell power plants (18) from the utility grid (10) and transitioning from the grid connected mode of operation to the grid independent mode of operation.]

[17. A fuel cell-powered generating system (8) at a site for inclusion as a distributed generating resource in a distributed generation utility power grid (10), comprising:

- d. multiple fuel cell power plants (18_{1-n}) at the site;
- e. at least one electrical load (14) located substantially at the site; and
- f. a site management system (11) operatively connected to each of the multiple fuel cell power plants (18_{1-n}), the at least one load (14), and the utility grid (10) for control-

ling the multiple fuel cell power plants (18_{1-n}) in an integrated manner, in, alternatively:

- i. a grid connected mode of operation having the fuel cell power plants (18) connected to the at least one load (14) and to the power grid (10), and
- ii. a grid independent mode of operation having the fuel cell power plants (18) connected to the at least one load (14) independent of connection to the power grid (10),

wherein the site management system (11) further includes high speed, static switching means (12) connected to the utility grid (10), the fuel cell power plants (18, 15), and the loads (14, 13, 39) for rapidly disconnecting the loads (14) and the fuel cell power plants (18) from the utility grid (10) and transitioning from the grid connected mode of operation to the grid independent mode of operation to substantially continuously maintain power to the loads (14) from the fuel cell power plants (18).]

18. A power generating system (8) at a site for inclusion as a distributed generating resource in a distributed generation utility power grid (10), comprising:

- a. multiple power plants (18_{1-n}) at the site;
- b. at least one electrical load (14_{L1-Lx}) located substantially at the site; and
- c. a site management system (11) operatively connected to each of the multiple power plants (18_{1-n}), the at least one load (14_{L1-Lx}), and the utility power grid (10) for issuing command signals for controlling multiple control functions of the power generating system in an integrated manner, including controlling the multiple power plants (18_{1-n}) and the at least one load (14_{L1-Lx}) in an integrated manner, with respect to each other and with respect to the at least one load, in, alternatively:
 - i. a grid connected mode of operation having the power plants (18) directly connected to the at least one load (14_{L1-Lx}) and to the utility power grid (10), and
 - ii. a grid independent mode of operation having the power plants (18) directly connected to the at least one load (14_{L1-Lx}) independent of connection to the utility power grid (10);

wherein the site management system is configured to control a transition of each power plant from operation in one of the grid connect and grid independent modes, to operation in the other.

19. The power generating system (8) of claim 18 wherein each power plant (18) generates power and includes a power plant controller (PPC) for controlling and monitoring the condition of the power plant and a power conditioning system (PCS) for conditioning the power provided by the power plant to the at least one load (14_{L1-Lx}), the power plant controller (PPC) further including signal processing logic (77, 79, 81, 85, 87) responsive to signals indicative of the monitored condition of the power plant for providing a signal (Kw Capacity—88) representative of the instant power output capacity of the respective power plant (18), and wherein the site management system (11, 94) is responsive to the instant power output capacity signals (Kw capacity—88) from each of the power plants (18_{1-n}) for providing a signal (Total Kw Capacity—95) representative of the total instant power output capacity of the multiple power plants (18_{1-n}).

20. The power generating system (8) of claim 19, further including a received utility dispatch signal (58, 97), and wherein the site management system (11) includes signal processing means (96, 97, 110) responsive to the received utility dispatch signal (58, 97) and the Total Kw Capacity signal (95) for selecting the lesser thereof to provide an

Actual Dispatch signal (98) and for comparing the Actual Dispatch signal (98) with the Total Kw Capacity signal (95) to provide a pro-rated dispatch signal (100), and responsive to the pro-rated dispatch signal (100) and to the Kw Capacity signals (88) from each of the respective power plants (18) to provide respective Set Power control signals (112, 90) for controlling dispatch power for each respective power plant (18_{1-n}).

21. The power generating system (8) of claim 20 wherein the signal processing means (96, 97, 110) of the site management system (11) determines a mathematical product of the pro-rated dispatch signal (100) and each of the Kw Capacity signals (88) from each of the respective power plants (18), to provide each of the respective Set Power Control signals (112, 90).

22. The power generating system (8) of claim 18, further including a received utility dispatch signal (58, 97), each power plant (18) generates power and includes a power plant controller (PPC) for controlling and monitoring a condition of the power plant and a power conditioning system (PCS) for conditioning the power provided by the power plant to the loads, the power plant controller (PPC) further including signal processing logic (77, 79, 81, 85, 87) responsive to signals indicative of the monitored condition of the power plant for providing a signal (Kw Capacity—88) representative of the instant power output capacity of the respective power plant (18), and wherein the site management system (11) includes signal processing means for dividing the received utility dispatch signal (58, 97) by the multiple number of power plants (18) to provide an initial per power plant dispatch signal value, for comparing the Kw Capacity signal (88) for an initial power plant (18) with the per power plant dispatch signal value and assigning to that plant as much of the per power plant dispatch signal value as allowed by the respective Kw Capacity signal (88), for storing any remainder value in overflow storage, for similarly comparing and assigning to each successive one of the multiple power plants (18) as much of the per power plant dispatch signal value as allowed by the respective Kw Capacity signal (88) and storing any respective remainder value, and for iteratively repeating the foregoing functions to allocate any remainder value remaining in the overflow storage.

23. The power generating system (8) of claim 19, wherein at least one of the at least one loads (14_{L1-Lx}) is connected (13) to receive power and the site management system (11) includes a power monitor (68) for providing a signal (69) representative of the total power demand of the at least one connected load, and further signal processing logic (34, 29) for comparing the total power demand signal (69) and the Total Kw Capacity signal (95) and, if and to the extent the total power demand exceeds the Total Kw Capacity, shedding the at least one connected load in accordance with a predetermined schedule.

24. The power generating system (8) of claim 23, wherein each at least one connected load is connected to the power plants (18) through respective selectively controlled contactors (13_{L1-Lx}), and wherein said shedding of the at least one connected load is effected by selectively opening respective ones of the contactors (13_{L1-Lx}).

25. The power generating system (8) of claim 18, wherein the site management system (11) is connected to receive dispatch signals from and provide status signals to, a remote utility via communications linkage (58, 62, 64, 61).

26. The power generating system (8) of claim 25, wherein the site management system includes a site supervisory controller (29) for effecting the integrated control of the multiple power plants (18) and providing control interface with the remote utility.

27. The power generating system (8) of claim 26, wherein the site management system (11) includes a means (60) operatively connected with the site supervisory controller (29) for manually selecting operation of the generating system (8) either in a local operating mode in which the multiple power plants (18) are controlled individually or in a supervisory operating mode in which the multiple power plants (18) are operated in a unified manner.

28. The power generating system (8) of claim 18, wherein the site management system (11) comprises a site supervisory controller (29) for effecting the integrated control of the multiple power plants (18), a load shed controller (34) connected (38, 70) to interact with the site supervisory controller (29) and the at least one load (14_{L1-Lx}) to control load shedding, and a site management controller (31) connected to each of the power plants (18) for controlling the power provided by the power plants (18) to the at least one load (14_{L1-Lx}).

29. The power generating system (8) of claim 19, wherein the site management system (11) comprises a site supervisory controller (29) for establishing, in response to a received utility power dispatch signal, power dispatch loading of the power plants (18) in an integrated manner when operating in the grid connected mode, a load shed controller (34) connected (38, 70) to interact with the site supervisory controller (29) and the at least one load (14_{L1-Lx}), and a site management controller (31) connected to the PCSs of each of the respective power plants (18) for controlling the transition of each power plant (18) from operation in one of the grid connected and the grid independent modes, to operation in the other.

30. The power generating system (8) of claim 29, wherein said site management system (11) further includes high speed, static switching means (12) connected to the utility power grid (10), the power plants (18), and the at least one load (14_{L1-Lx}) for rapidly disconnecting the at least one load (14_{L1-Lx}) and the power plants (18) from the utility power grid (10) and transitioning from the grid connected mode of operation to the grid independent mode of operation.

31. The power generating system (8) of claim 19, wherein initial power rating signals (Kw Rating—76) representative of a base power capacity are provided for each of the multiple power plants (18_{1-n}), and the signal processing logic (77, 79) is responsive to the monitored condition of each of the respective power generating means (F. C._{1-n}) to foldback the base power capacity (Kw Rating—76) of the respective power plant (18) by an amount predetermined in accordance with the monitored condition to thereby provide the respective instant power output capacity signal value (Kw Capacity—88).

32. A power generating system (8) at a site for inclusion as a distributed generating resource in a distributed generation utility power grid (10), comprising:

- a. multiple power plants (18_{1-n}) at the site;
- b. at least one electrical load (14_{L1-Lx}) located substantially at the site;
- c. a site management system (11) operatively connected to each of the multiple power plants (18_{1-n}), the at least one load (14_{L1-Lx}), and the utility power grid (10) for controlling the multiple power plants (18_{1-n}) and the at least one load (14_{L1-Lx}) in an integrated manner, with respect to each other and with respect to the at least one load, in, alternatively:
 - i. a grid connected mode of operation having the power plants (18) directly connected to the at least one load (14_{L1-Lx}) and to the utility power grid (10), and
 - ii. a grid independent mode of operation having the power plants (18) directly connected to the at least

one load (14_{L1-Lx}) independent of connection to the utility power grid (10), wherein the site management system is configured to control a transition of each power plant from operation in one of the grid connect and grid independent modes, to operation in the other, and wherein each power plant (18) includes means (F. C.) for generating power, a power plant controller (PPC) for controlling and monitoring a condition of the power generating means (F. C.), and a power conditioning system (PCS) for conditioning the power provided by the power generating means to the loads, the power plant controller (PPC) further including signal processing logic (77, 79, 81, 85, 87) responsive to signals indicative of the monitored condition of the power generating means (F. C.) for providing a signal (Kw Capacity—88) representative of the instant power output capacity of the respective power plant (18).

33. The power generating system (8) of claim 32, wherein said site management system (11) further includes high speed, static switching means (12) connected to the utility power grid (10), the power plants (18), and the at least one load (14_{L1-Lx}) for rapidly disconnecting the at least one load (14_{L1-Lx}) and the power plants (18) from the utility power grid (10) and transitioning from the grid connected mode of operation to the grid independent mode of operation.

34. A power generating system (8) at a site for inclusion as a distributed generating resource in a distributed generation utility power grid (10), comprising:

- a. multiple power plants (18_{1-n}) at the site;
- b. at least one electrical load (14_{L1-Lx}) located substantially at the site; and
- c. a site management system (11) operatively connected to each of the multiple power plants (18_{1-n}), the at least one load (14_{L1-Lx}), and the utility grid (10) for controlling the multiple power plants (18_{1-n}) and the at least one load (14_{L1-Lx}) in an integrated manner, with respect to each other and with respect to the at least one load, in, alternatively:
 - i. a grid connected mode of operation having the power plants (18) directly connected to the at least one load (14_{L1-Lx}) and to the utility power grid (10), and
 - ii. a grid independent mode of operation having the power plants (18) directly connected to the at least one load (14_{L1-Lx}) independent of connection to the utility power grid (10), wherein the site management system is configured to control a transition of each power plant from operation in one of the grid connect and grid independent modes, to operation in the other, and wherein the site management system (11) further includes high speed, static switching means (12) connected to the utility power grid (10), the power plants (18), and the at least one load (14_{L1-Lx}) for rapidly disconnecting the at least one load (14_{L1-Lx}) and the power plants (18) from the utility power grid (10) and transitioning from the grid connected mode of operation to the grid independent mode of operation to substantially continuously maintain power to the at least one load (14_{L1-Lx}) from the power plants (18).

35. A power generating system (8) at a site for inclusion as a distributed generating resource in a distributed generation utility power grid (10), comprising:

- a. multiple power plants (18_{1-n}) at the site;
- b. at least one electrical load (14_{L1-Lx}) located substantially at the site; and

- c. a site management system (11) operatively connected to each of the multiple power plants (18_{1-n}), the at least one load (14_{L1-Lx}), and the utility power grid (10) for controlling the multiple power plants (18_{1-n}) in an integrated manner, in, alternatively:
- iii. a grid connected mode of operation having the power plants (18) connected to the at least one load (14_{L1-Lx}) and to the utility power grid (10), and
 - iv. a grid independent mode of operation having the power plants (18) connected to the at least one load (14_{L1-Lx}) independent of connection to the utility power grid (10);

wherein each power plant (18) generates power and includes a power plant controller (PPC) for controlling and monitoring the condition of the power plant and a power conditioning system (PCS) for conditioning the power provided by the power plant to the at least one load (14_{L1-Lx}), the power plant controller (PPC) further including signal processing logic (77, 79, 81, 85, 87) responsive to signals indicative of the monitored condition of the power plant for providing a signal (Kw Capacity—88) representative of the instant power output capacity of the respective power plant (18), and wherein the site management system (11, 94) is responsive to the instant power output capacity signals (Kw capacity—88) from each of the power plants (18_{1-n}) for providing a signal (Total Kw Capacity—95) representative of the total instant power output capacity of the multiple power plants (18_{1-n}); and

further including a received utility dispatch signal (58, 97), and wherein the site management system (11) includes signal processing means (96, 97, 110) responsive to the received utility dispatch signal (58, 97) and the Total Kw Capacity signal (95) for selecting the lesser thereof to provide an Actual Dispatch signal (98) and for comparing the Actual Dispatch signal (98) with the Total Kw Capacity signal (95) to provide a pro-rated dispatch signal (100), and responsive to the pro-rated dispatch signal (100) and to the Kw Capacity signals (88) from each of the respective power plants (18) to provide respective Set Power control signals (112, 90) for controlling dispatch power for each respective power plant (18_{1-n}).

36. The power generating system (8) of claim 35 wherein the signal processing means (96, 97, 110) of the site management system (11) determines a mathematical product of the pro-rated dispatch signal (100) and each of the Kw Capacity signals (88) from each of the respective power plants (18), to provide each of the respective Set Power Control signals (112, 90).

37. A power generating system (8) at a site for inclusion as a distributed generating resource in a distributed generation utility power grid (10), comprising:

- a. multiple power plants (18_{1-n}) at the site;
- b. at least one electrical load (14_{L1-Lx}) located substantially at the site; and
- c. a site management system (11) operatively connected to each of the multiple power plants (18_{1-n}), the at least one load (14_{L1-Lx}), and the utility power grid (10) for issuing command signals for controlling multiple control functions of the power generating system in an integrated manner, including controlling the multiple power plants (18_{1-n}) in an integrated manner, in, alternatively:
 - i. a grid connected mode of operation having the power plants (18) connected to the at least one load (14_{L1-Lx}) and to the utility power grid (10), and
 - ii. a grid independent mode of operation having the power plants (18) connected to the at least one load (14_{L1-Lx}) independent of connection to the utility power grid (10); and

further including a received utility dispatch signal (58, 97), each power plant (18) generates power and includes a power plant controller (PPC) for controlling and monitoring a condition of the power plant and a power conditioning system (PCS) for conditioning the power provided by the power plant to the loads, the power plant controller (PPC) further including signal processing logic (77, 79, 81, 85, 87) responsive to signals indicative of the monitored condition of the power plant for providing a signal (Kw Capacity—88) representative of the instant power output capacity of the respective power plant (18), and wherein the site management system (11) includes signal processing means for dividing the received utility dispatch signal (58, 97) by the multiple number of power plants (18) to provide an initial per power plant dispatch signal value, for comparing the Kw Capacity signal (88) for an initial power plant (18) with the per power plant dispatch signal value and assigning to that plant as much of the per power plant dispatch signal value as allowed by the respective Kw Capacity signal (88), for storing any remainder value in overflow storage, for similarly comparing and assigning to each successive one of the multiple power plants (18) as much of the per power plant dispatch signal value as allowed by the respective Kw Capacity signal (88) and storing any respective remainder value, and for iteratively repeating the foregoing functions to allocate any remainder value remaining in the overflow storage.

* * * * *