

US00RE41778E

(19) **United States**
(12) **Reissued Patent**
Maruyama et al.

(10) **Patent Number:** **US RE41,778 E**
(45) **Date of Reissued Patent:** **Sep. 28, 2010**

(54) **RECORDING-MATERIAL TYPE DETERMINATION APPARATUS AND METHOD AND IMAGE FORMING APPARATUS**

6,668,144 B2 12/2003 Maruyama 399/45
6,684,048 B2 1/2004 Caruthers et al. 399/296
6,731,886 B2 5/2004 Takeda 399/45
2002/0071688 A1 6/2002 Maruyama 399/45

(75) Inventors: **Shoji Maruyama**, Shizuoka (JP);
Masanori Akita, Shizuoka (JP)

FOREIGN PATENT DOCUMENTS
EP 1 215 878 A2 6/2002
EP 1 308 798 A2 5/2003
JP 11-27103 1/1999

(73) Assignee: **Canon Kabushiki Kaisha**, Tokyo (JP)

(21) Appl. No.: **11/104,643**
(22) Filed: **Apr. 13, 2005**

OTHER PUBLICATIONS

Official Letter/Search Report, dated Feb. 2, 2009, issued by the European Patent Office, in European Application No. 03008361.2.

Related U.S. Patent Documents

Reissue of:

(64) Patent No.: **6,801,727**
Issued: **Oct. 5, 2004**
Appl. No.: **10/409,137**
Filed: **Apr. 9, 2003**

Primary Examiner—David M. Gray
Assistant Examiner—Gregory H Curran
(74) Attorney, Agent, or Firm—Fitzpatrick, Cella, Harper & Scinto

(30) **Foreign Application Priority Data**

Apr. 12, 2002 (JP) 2002-109922

(51) **Int. Cl.**
G03G 15/00 (2006.01)

(57) **ABSTRACT**

To provide a recording-material type determination apparatus and recording-material type determination method which can determine the type of recording material using simple calculations as well as to provide an image forming apparatus capable of obtaining stable image quality independent of the type of recording material using the apparatus and method.

(52) **U.S. Cl.** **399/45**; 399/53; 399/66;
399/67; 400/703; 400/708; 356/601

(58) **Field of Classification Search** 399/45,
399/53, 66-68; 356/601; 400/703, 708
See application file for complete search history.

Based on data read by a read unit which reads surface images of recording material, a first calculation unit calculates the depth of irregularities in the surface of recording material and stores the results of calculation in a register A while a second calculation unit calculates the spacing of irregularities on the surface of the recording material and stores the results of calculation in a register B. Based on the values in the registers A and B, the type of recording material such as gloss paper, plain paper, rough paper or OHT is determined.

(56) **References Cited**

U.S. PATENT DOCUMENTS

5,109,236 A 4/1992 Watanabe et al. 346/76 PH
5,654,799 A 8/1997 Chase et al. 356/371
5,689,757 A 11/1997 Ferrante et al. 399/45
6,215,552 B1 4/2001 Acquaviva et al. 356/371
6,477,892 B1 11/2002 Lindig 73/105
6,629,452 B2 10/2003 Lindig 73/105

19 Claims, 9 Drawing Sheets

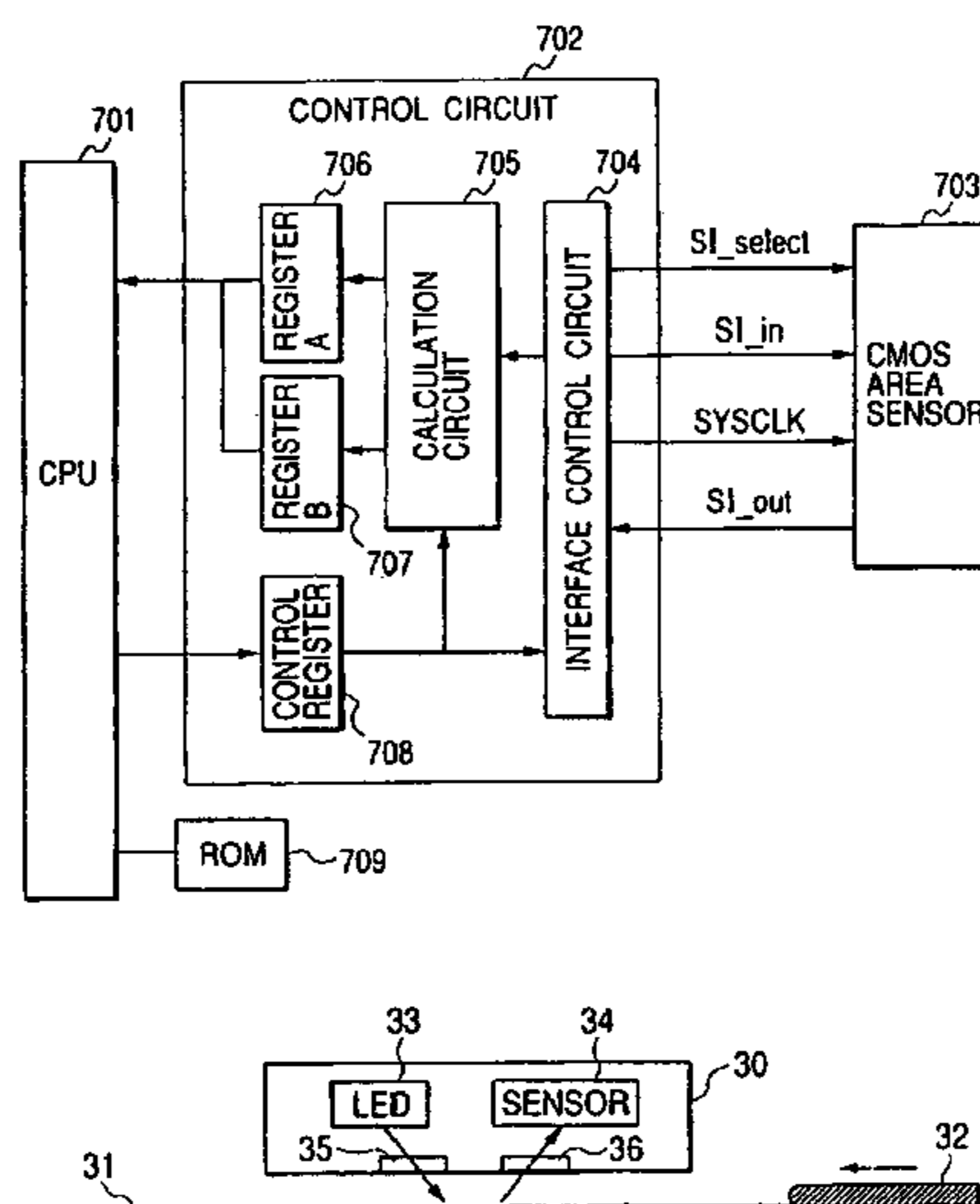

FIG. 1

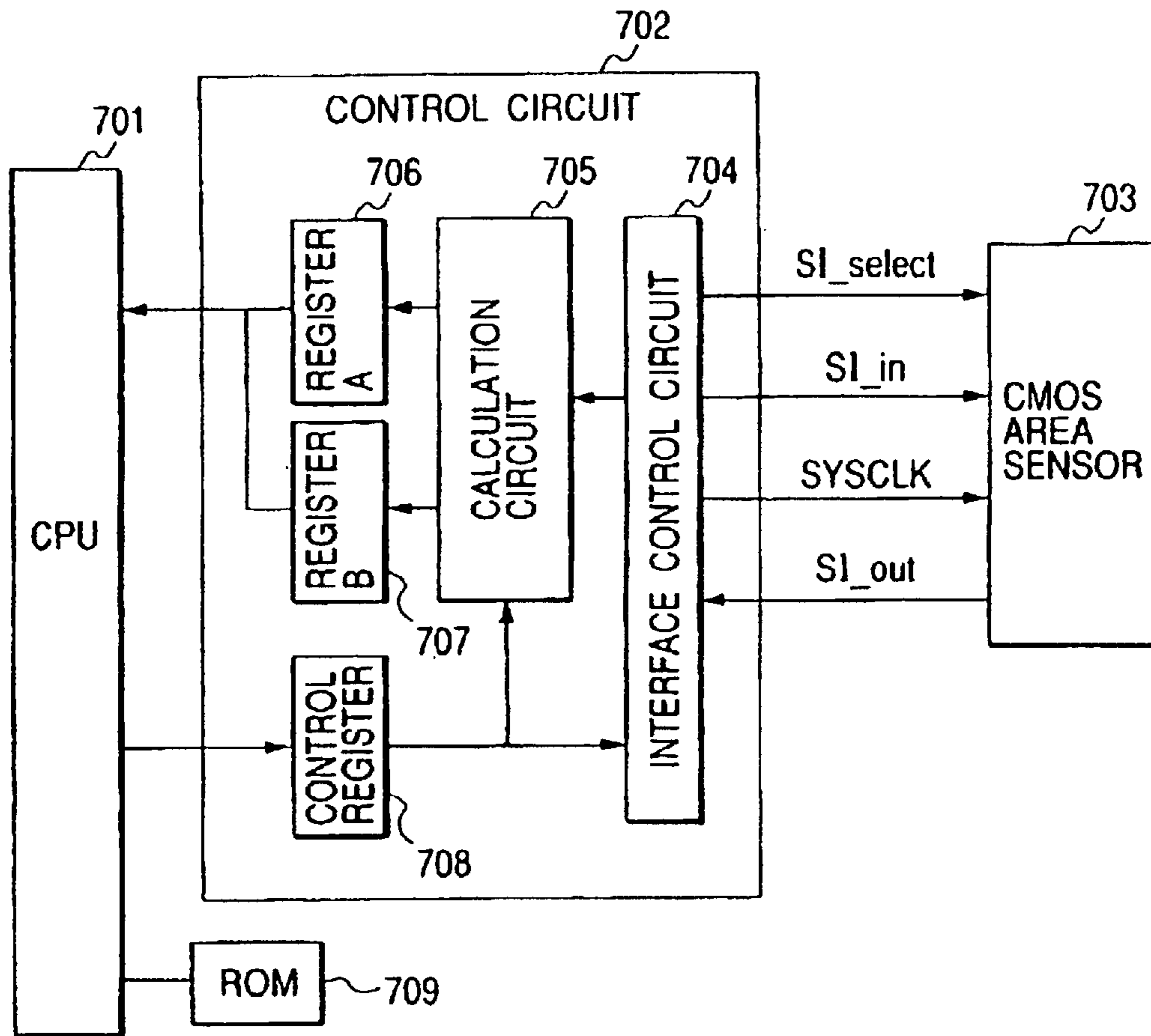

FIG. 2

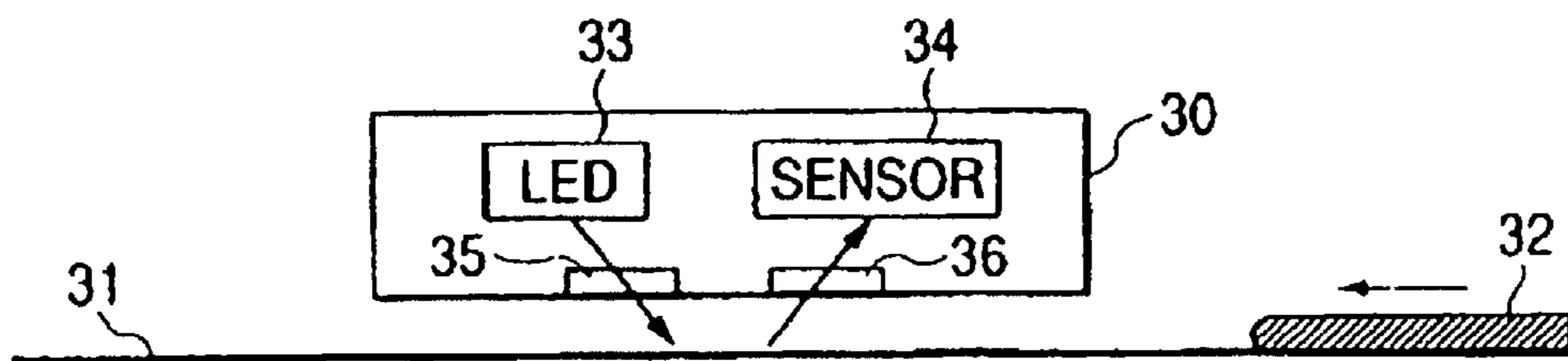

FIG. 3A

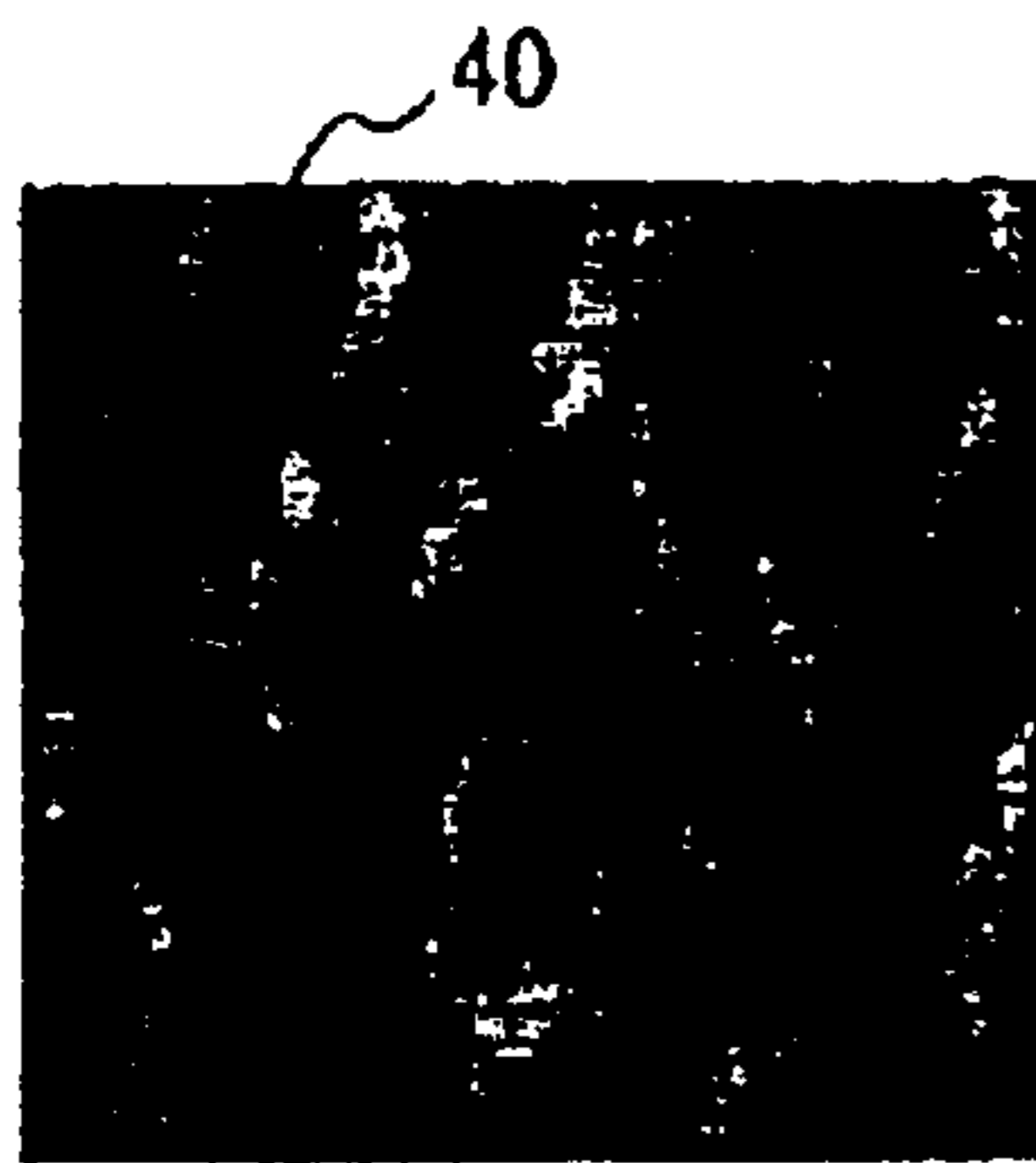

FIG. 3B

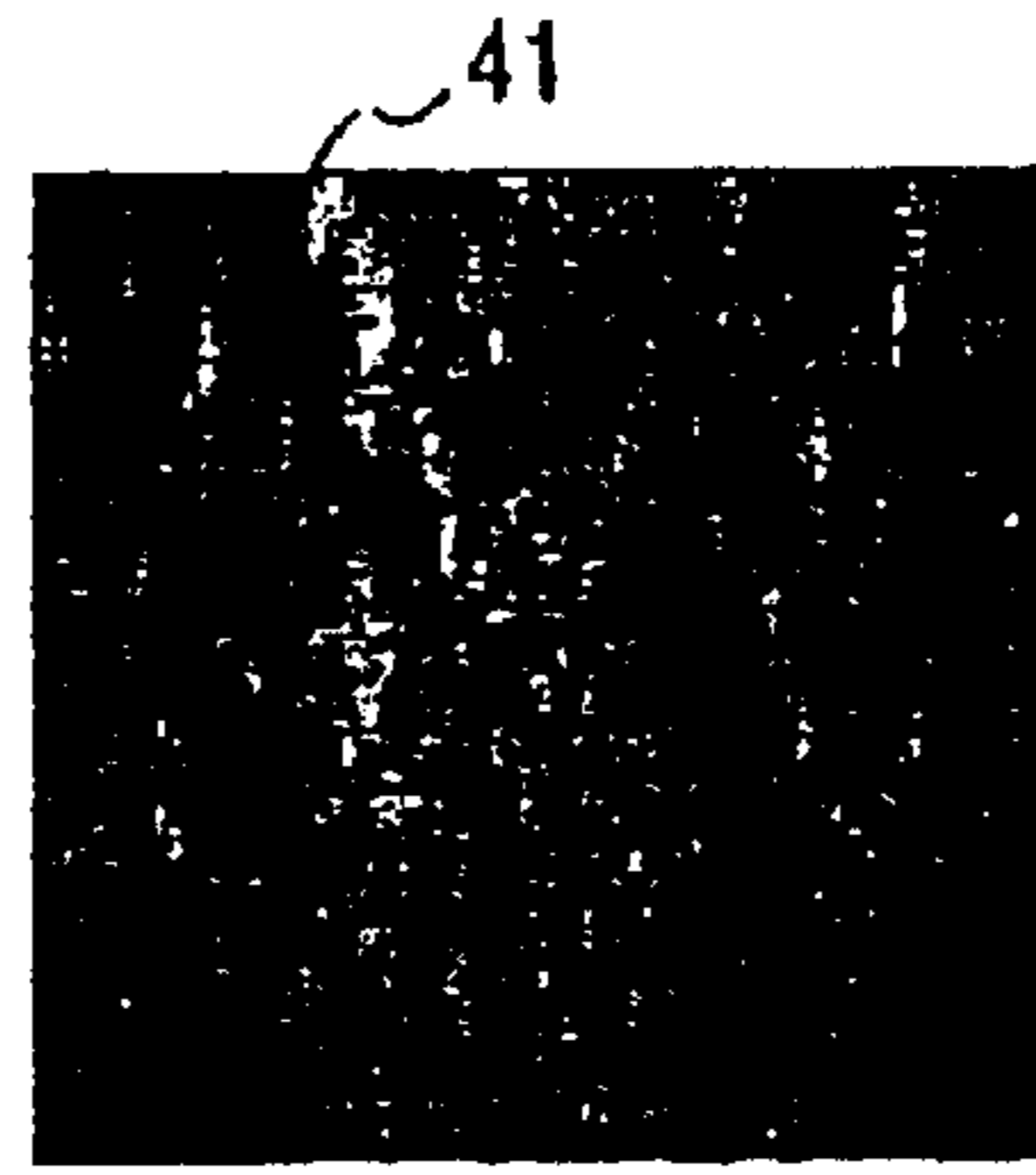

FIG. 3C



FIG. 3D

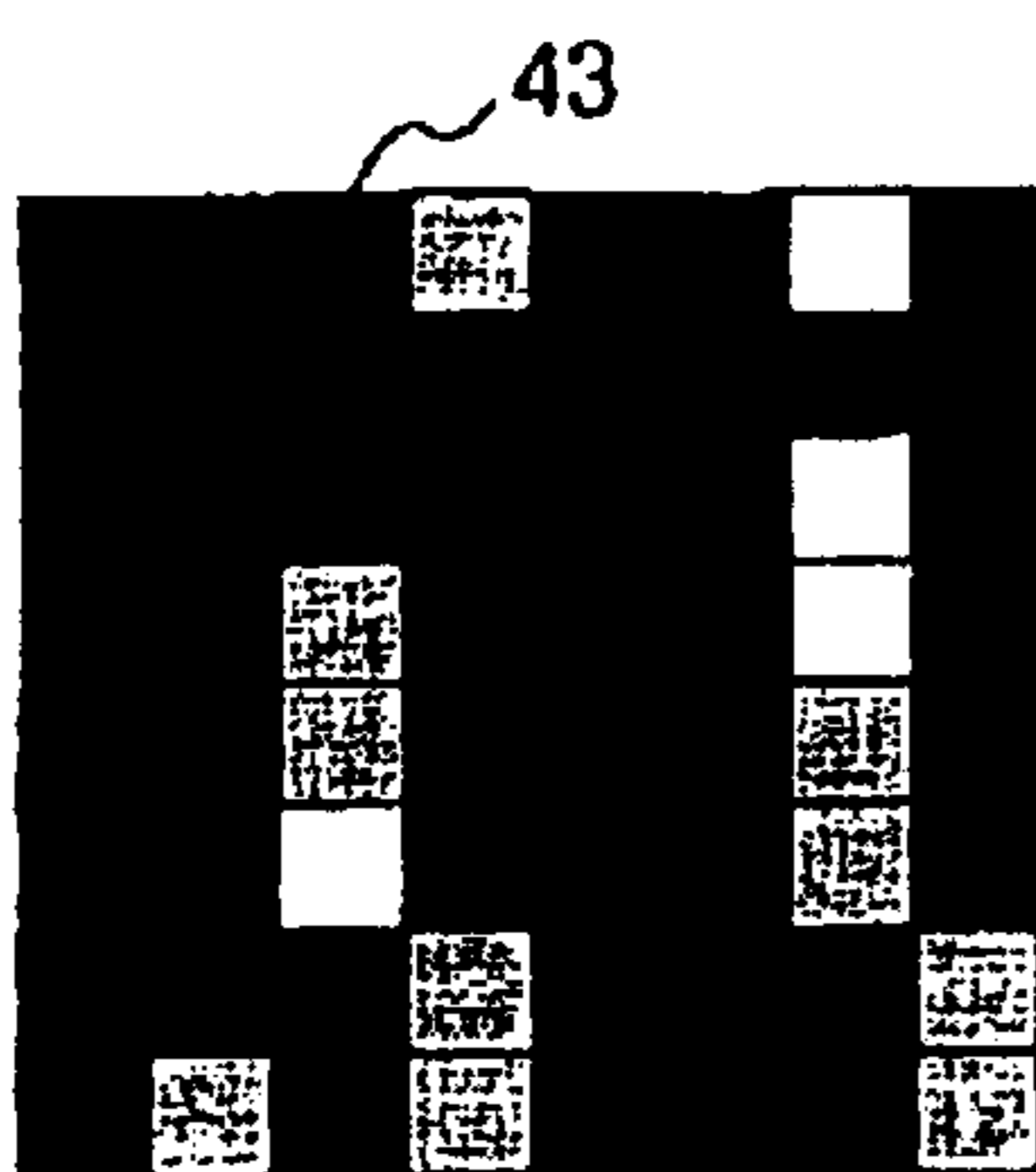

FIG. 3E

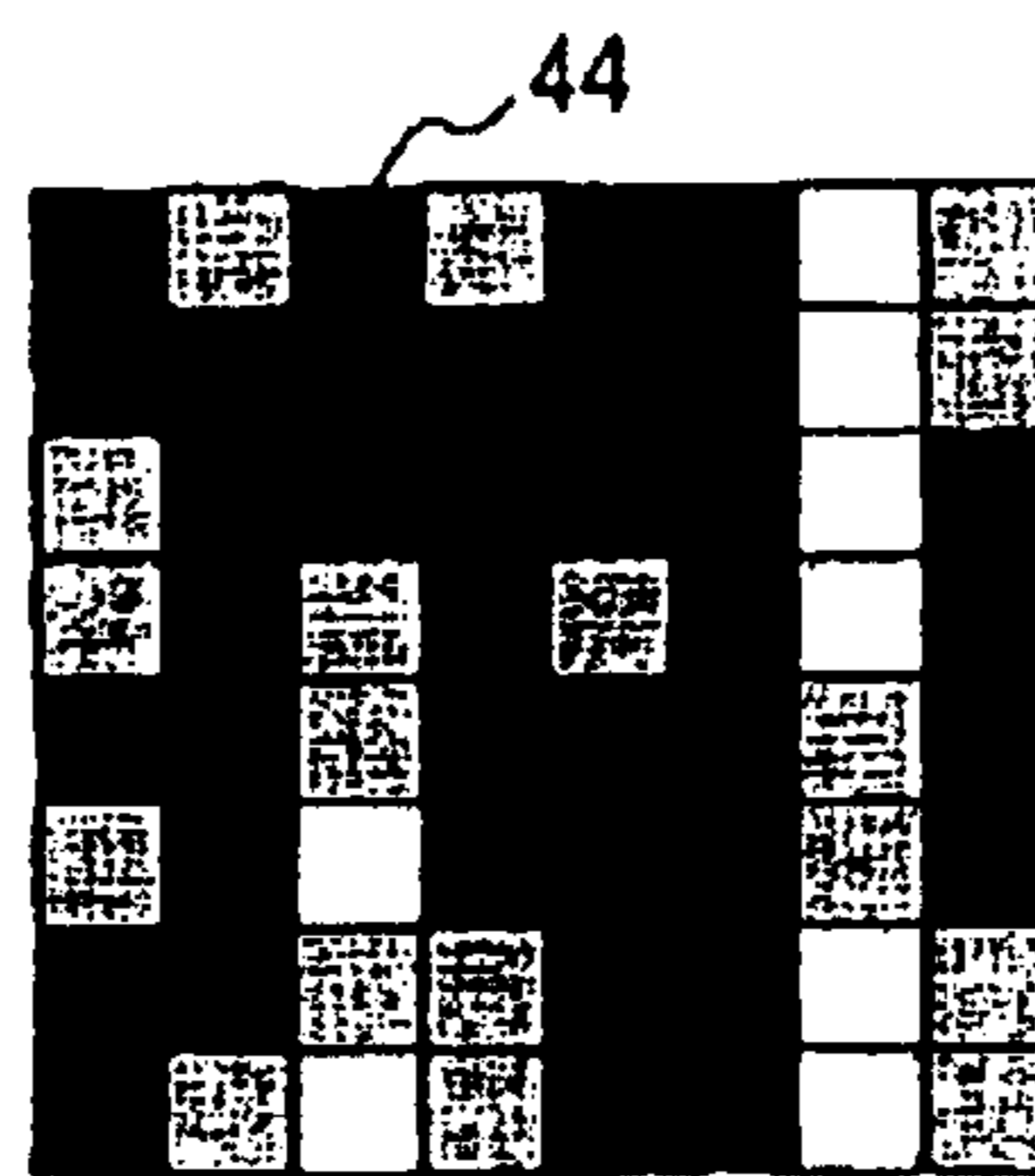

FIG. 3F

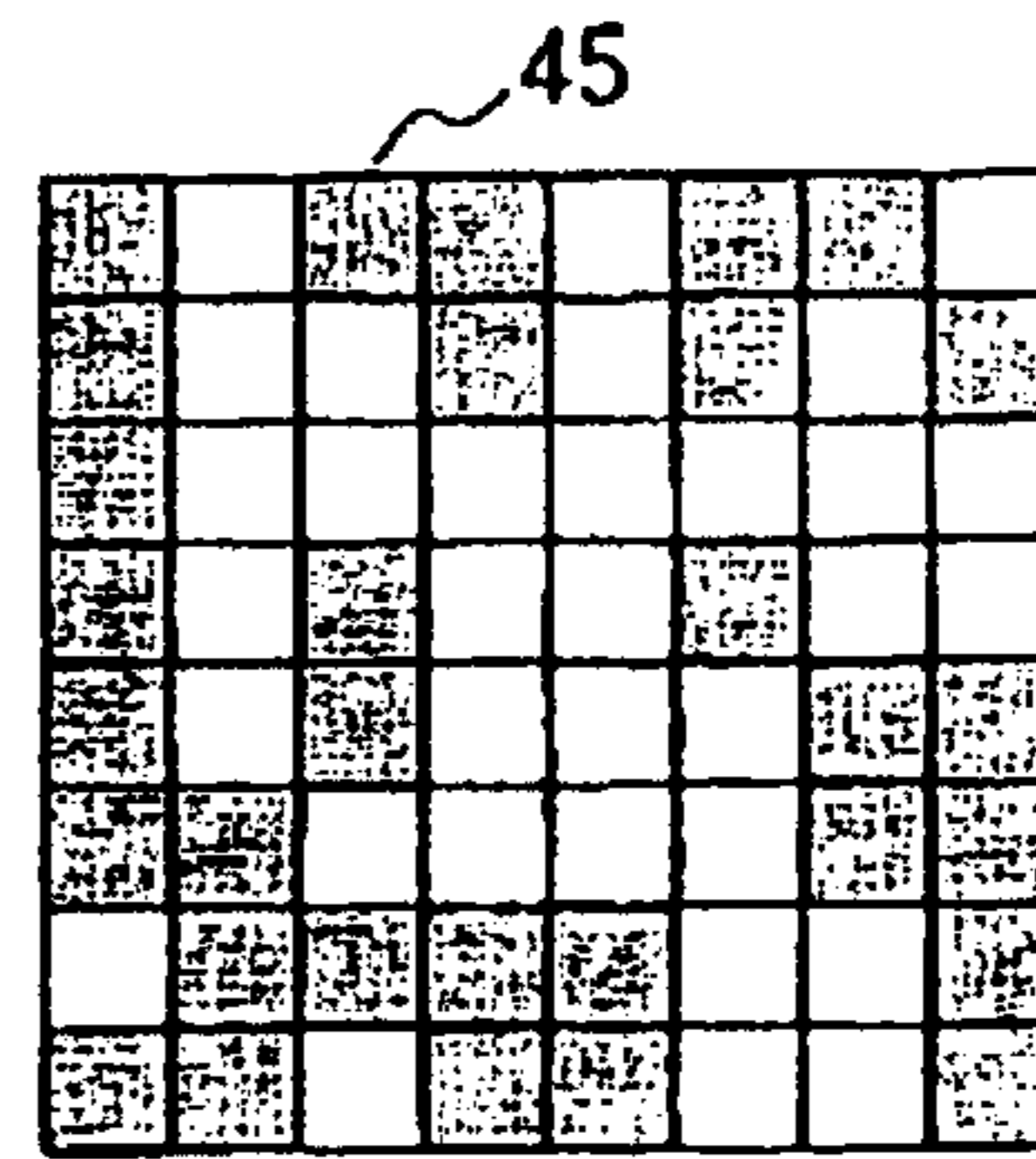

FIG. 4

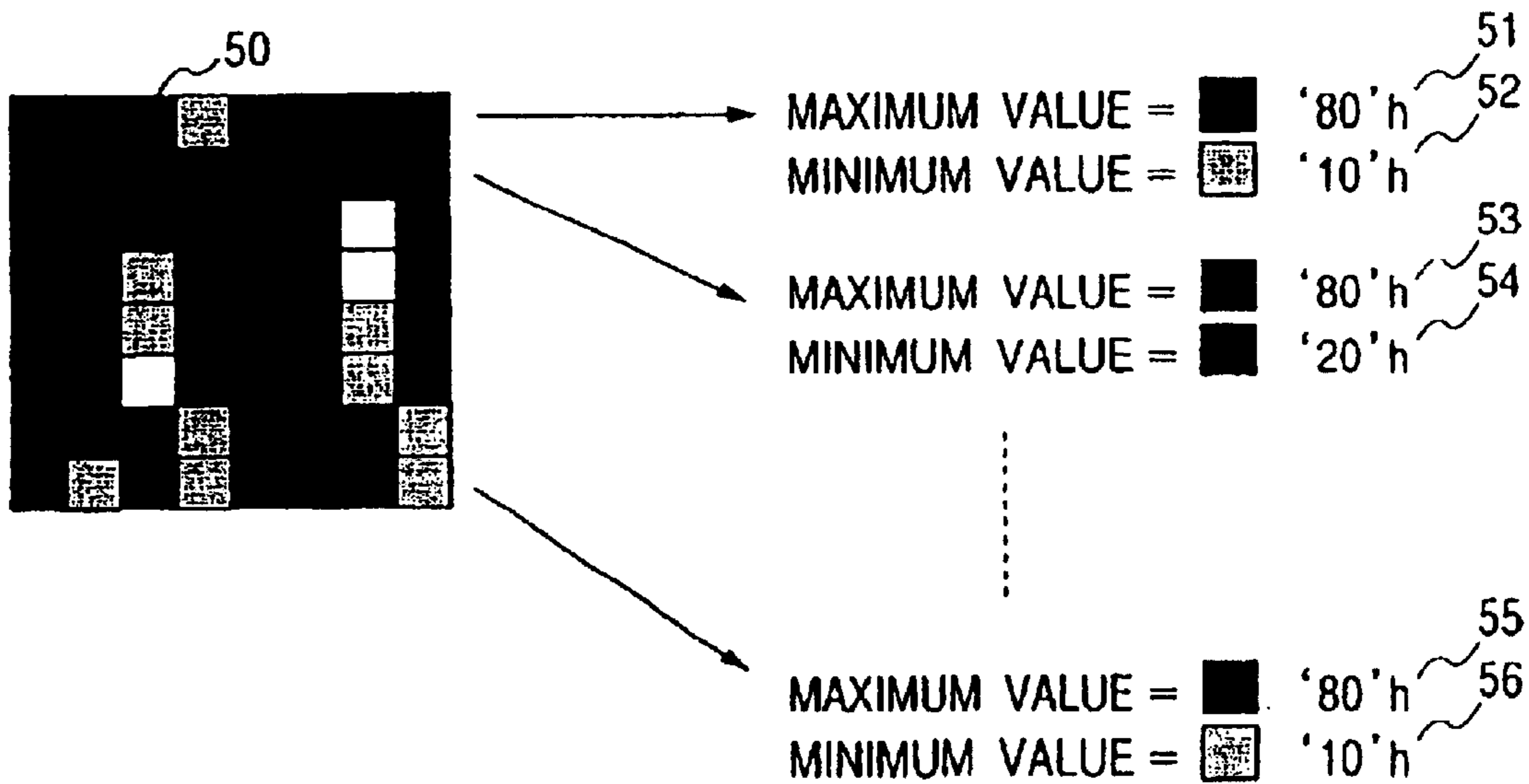

FIG. 5

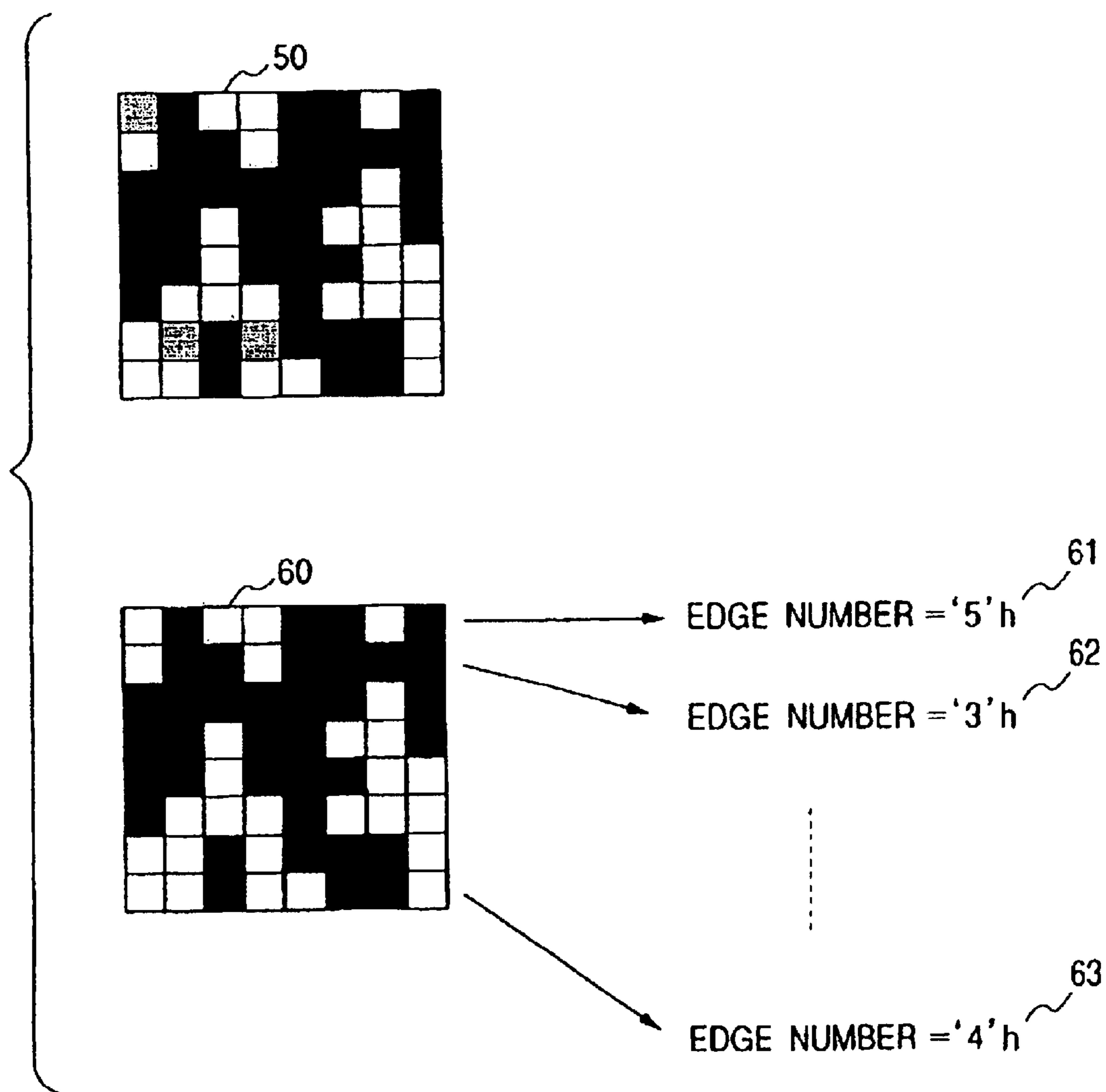

FIG. 6

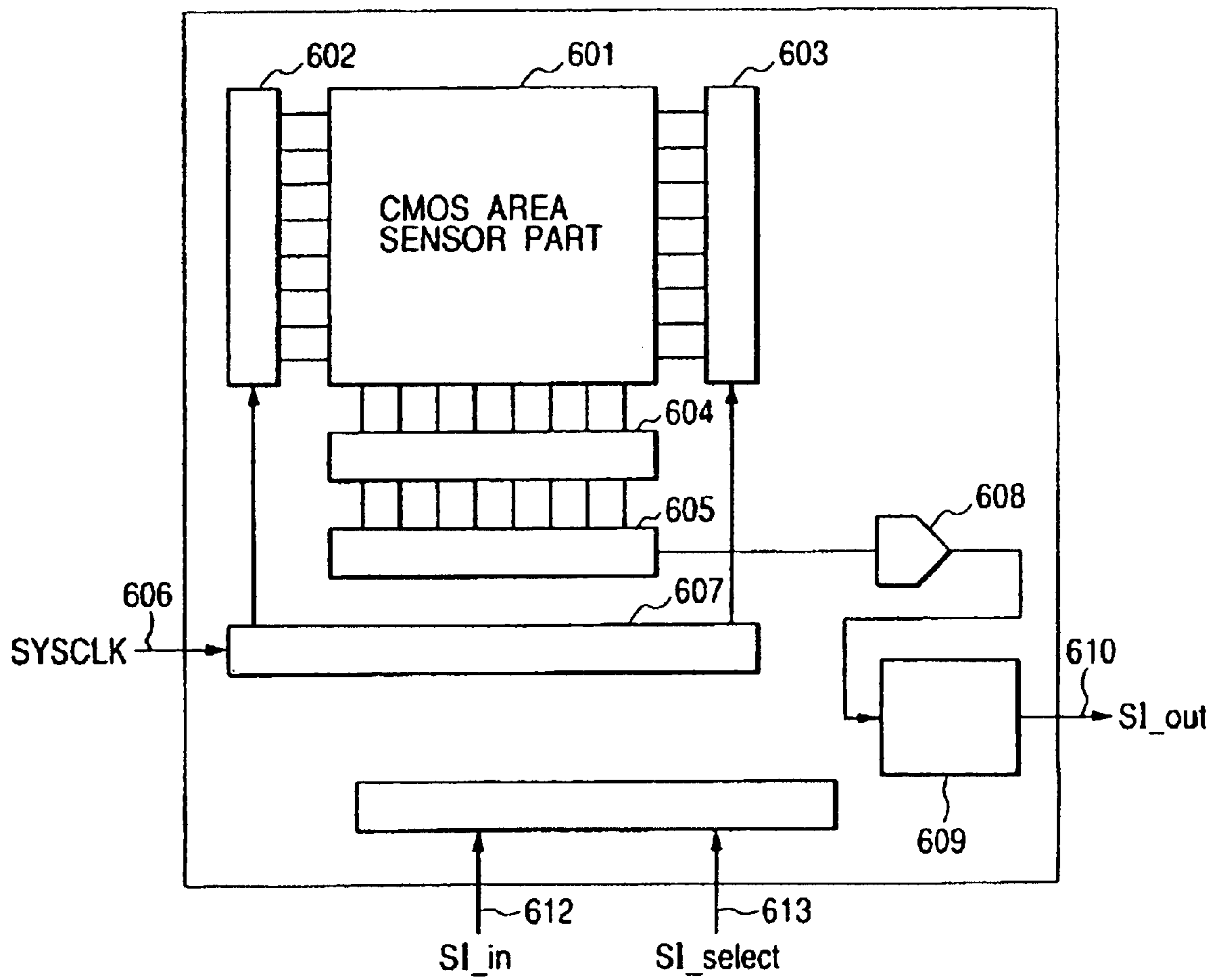

FIG. 7

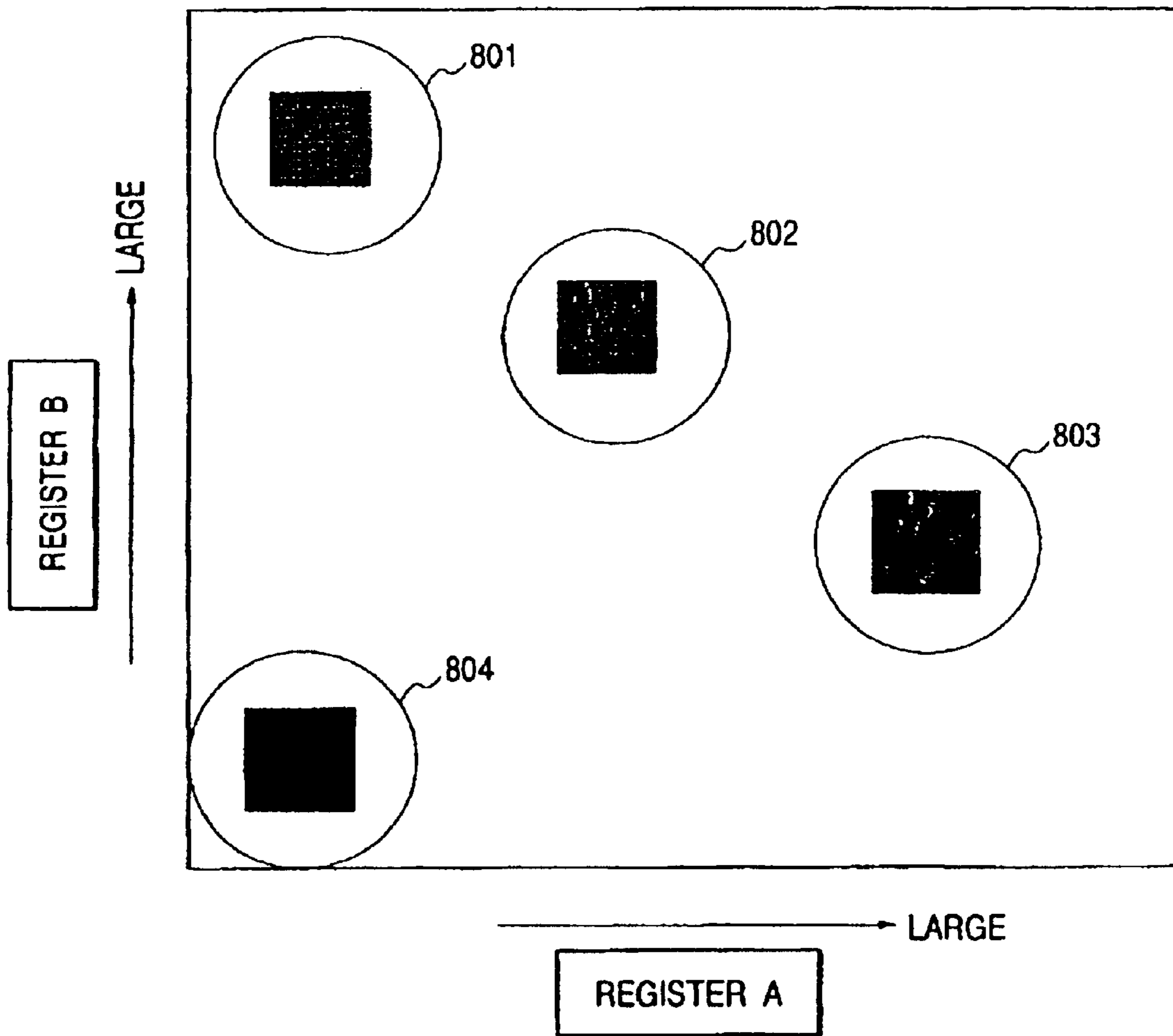

FIG. 8

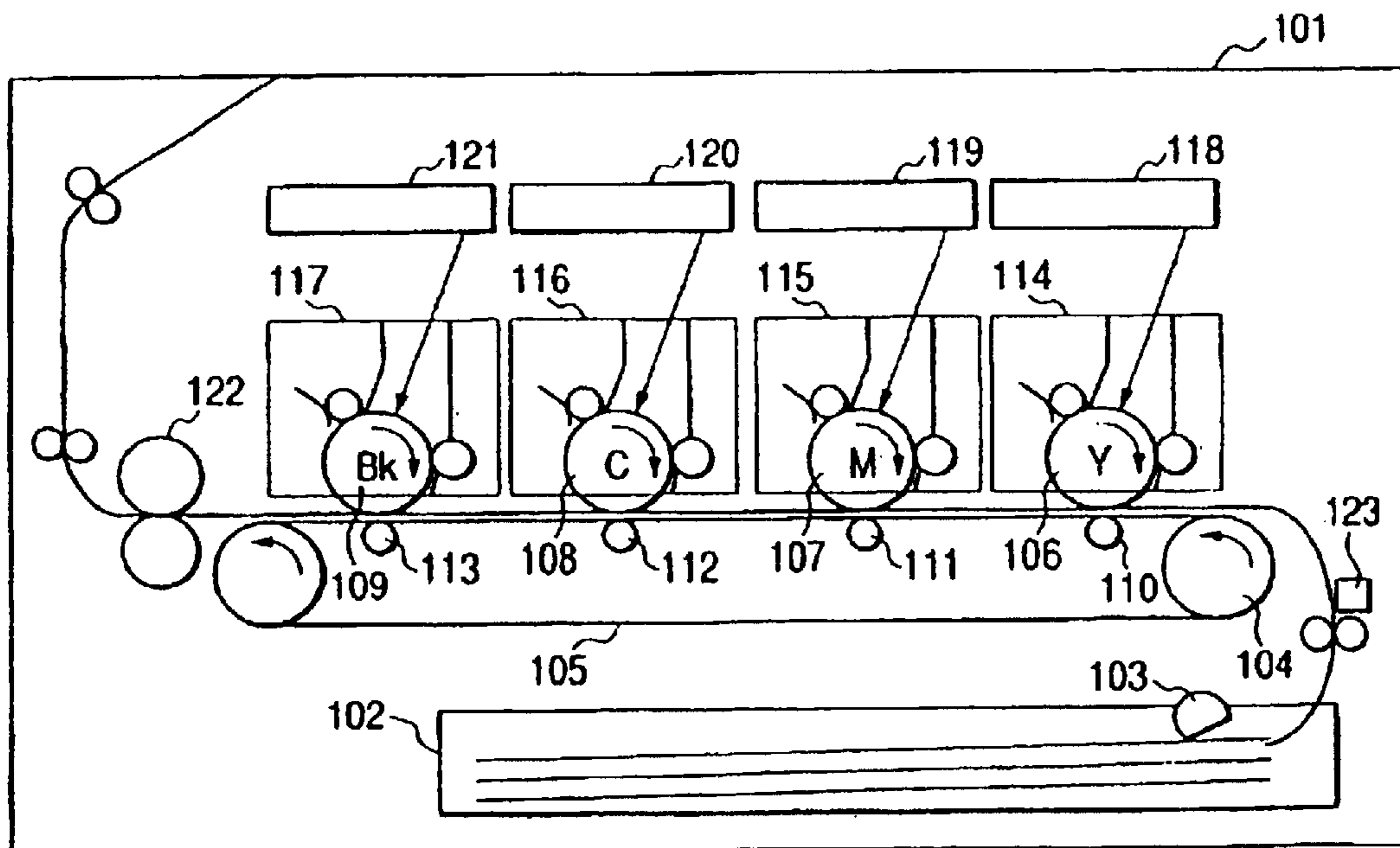

FIG. 9

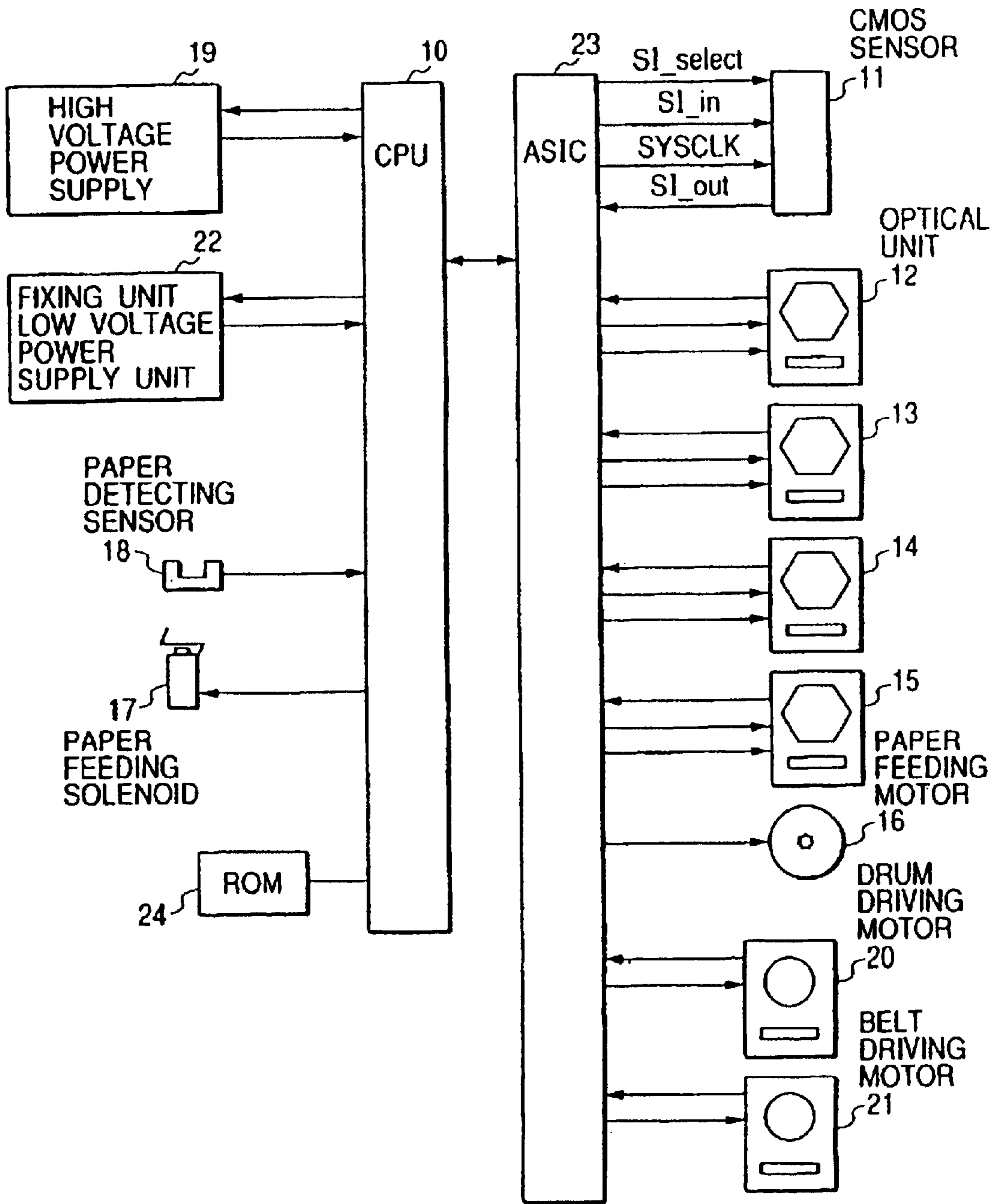
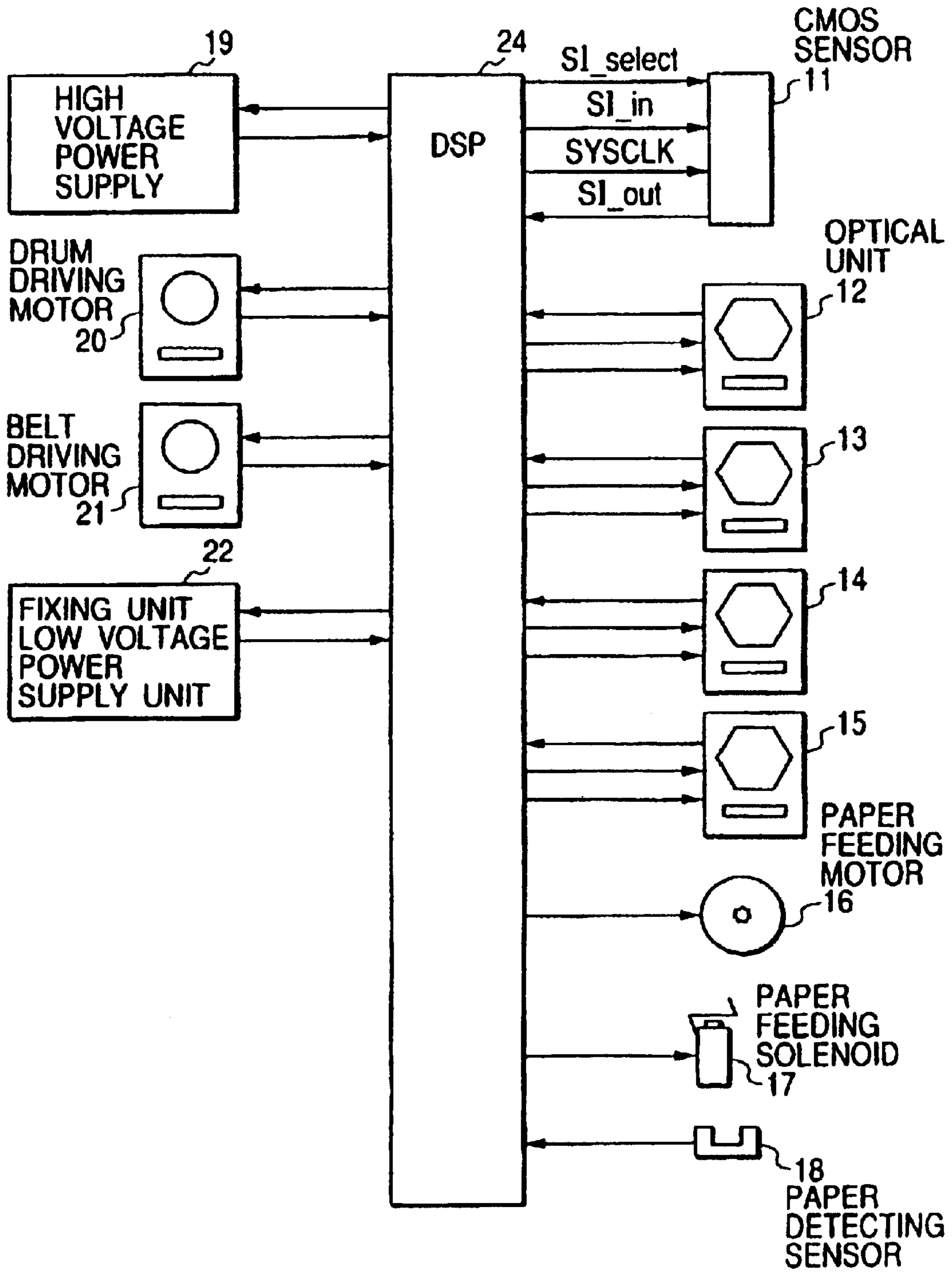

FIG. 10



**RECORDING-MATERIAL TYPE
DETERMINATION APPARATUS AND
METHOD AND IMAGE FORMING
APPARATUS**

Matter enclosed in heavy brackets [] appears in the original patent but forms no part of this reissue specification; matter printed in italics indicates the additions made by reissue.

Notice: More than one reissue application has been filed for the reissue of U.S. Pat. No. 6,801,727. The reissue applications are (1) reissue application Ser. No. 11/104,643 filed on Apr. 13, 2005 (the present application) and (2) 12/203,464 filed on Sep. 3, 2008, which is a continuation of reissue application 11/104,643.

BACKGROUND OF THE INVENTION

1. Field of the Invention

The present invention relates to a recording-material type determination apparatus, recording-material type determination method, and image forming apparatus such as a copier or laser printer which controls imaging conditions using the recording-material type determination apparatus.

2. Related Background Art

An image forming apparatus such as a copier or laser printer comprises a latent-image bearing member which bears a latent image, a developing apparatus which visualizes the latent image as a developer image (developed image) by applying developer to the latent-image bearing member, transferring means which transfers the developer image formed by the developing apparatus to recording material conveyed in a predetermined direction, and a fixing apparatus which fixes the developer image on the recording material by applying heat and pressure to the recording material under predetermined fixing conditions after the developer image has been transferred to the recording material by the transferring means.

Conventionally, such an image forming apparatus controls to set fixing conditions (e.g. fixing temperature and conveying speed of the recording paper passing through the fixing apparatus) according to user settings after the user sets a size and type (also called a paper type) of the recording paper, which is recording material, on a control panel or the like installed, for example, on the image forming apparatus main body.

Alternatively, an image forming apparatus incorporates a sensor for determining recording material and controls developing conditions, fixing conditions or transfer conditions variably according to the type of recording material.

In the latter case, in particular, Japanese Patent Application Laid-Open No. 11-27103, for example, proposes a technique for picking up a surface picture of recording material using a CCD sensor, converting it into fractal dimension information, and thereby detecting the surface flatness of the recording material.

However, the image forming apparatus has the following problems.

1) When calculations are performed using fractal dimensions, picture information is binarized according to a certain threshold and the number of black pixels is counted based on the binarized information. Then, the picture information is visualized roughly and binarized similarly and the number of black pixels is counted again based on the binarized information. This process is repeated several times, taking a very long calculation time.

Therefore, especially if surface flatness varies widely within one sheet of recording material, video images of a plurality of points on the recording material need to be detected. In such a case, it takes time to detect the surface flatness of the recording material, reducing the throughput (the number of prints per unit time) of the image forming apparatus

2) The calculation method, if implemented by a hardware circuit, will increase the scale of the circuit, reducing the cost-effectiveness of the image forming apparatus significantly.

3) Furthermore, if implemented by a software, the calculation method, which binarizes captured images and performs calculation, binarizes the, resulting images and performs calculation, and so on, requires a memory (RAM) to buffer the captured images and the images resulting from calculations. Especially if a sensor with increased pixel counts is used to improve detection accuracy, the buffer memory will increase in size, reducing the cost-effectiveness of the image forming apparatus significantly.

SUMMARY OF THE INVENTION

The present invention has been made in view of the above circumstances. Its object is to provide a recording-material type determination apparatus and recording-material type determination method which can determine the type of recording material (i.e., determine the flatness of recording material) using simple calculations as well as to provide an image forming apparatus capable of obtaining stable image quality independent of the type of recording material using the apparatus and method.

Another object of the present invention is to provide a recording material type determination apparatus comprising: a light emit unit, adapted to illuminate a surface of recording material; a read unit, adapted to read an illuminated region on the surface of the recording material as a video image; a first calculation unit adapted to calculate information about depth of irregularities in the surface of the recording material based on video information read by the read unit; a second calculation unit adapted to calculate information about spacing of irregularities on the surface of the recording material based on the video information read by the read unit; and a determination unit adapted to determine a type of recording material based on calculation results produced by the first calculation unit and the second calculation unit.

Yet another object of the present invention is to provide a recording-material type determination apparatus comprising: an input unit adapted to input a video image of a surface of recording material; a first calculation unit adapted to calculate information about depth of irregularities in a surface of the recording material based on video information inputted in the input unit; a second calculation unit adapted to calculate information about spacing of irregularities on the surface of the recording material based on the video information inputted in the input unit; and a determination unit adapted to determine a type of recording material based on calculation results produced by the first calculation unit and the second calculation unit.

Yet another object of the present invention is to provide a recording-material type determination method comprising: a read step of reading a surface of recording material as a video image; a first calculation step of calculating information about depth of irregularities in the surface of the recording material based on results of the read step; a second calculation step of calculating information about spacing of irregularities on the surface of the recording material based

on the results of the read step; and a determination step of determining a type of recording material based on calculation results produced in the first calculation step and the second calculation step.

Yet another object of the present invention is to provide an image forming apparatus comprising: a conveyor adapted to convey recording material; an image forming unit which forms an image on the recording material conveyed by the conveyor; a light emit unit, adapted to illuminate a surface of recording material; a read unit, adapted to read an illuminated region on the surface of the recording material as a video image; a first calculation unit adapted to calculate information about depth of irregularities in the surface of the recording material based on video information read by the read unit; a second calculation unit adapted to calculate information about spacing of irregularities on the surface of the recording material based on the video information read by the read unit; a determination unit adapted to determine a type of recording material based on calculation results produced by the first calculation unit and the second calculation unit; and a controller which controls image forming conditions of the image forming unit based on the type of recording material determined by the determination unit.

Other objects, features and advantages of the present invention will become readily apparent from the following detailed description taken in conjunction with the accompanying drawings.

BRIEF DESCRIPTION OF THE DRAWINGS

FIG. 1 is a block diagram showing configuration of a first example;

FIG. 2 is a diagram showing schematic configuration of an image sensor;

FIGS. 3A, 3B, 3C, 3D, 3E and 3F are diagrams showing surface images of recording materials;

FIG. 4 is an explanatory diagram of first calculation means;

FIG. 5 is an explanatory diagram of second calculation means;

FIG. 6 is a block diagram showing circuit configuration of a CMOS area sensor;

FIG. 7 is a diagram showing determination results of recording materials;

FIG. 8 is a sectional view showing schematic configuration of a second example;

FIG. 9 is a control block diagram of the second example; and

FIG. 10 is a control block diagram of a third example.

DESCRIPTION OF THE PREFERRED EMBODIMENTS

A preferred embodiment of the present invention will be described in detail below citing examples of a "recording-material type determination apparatus" and "image forming apparatus." Incidentally, the present invention can be implemented not only as apparatus, but also as methods, being backed up by the description of the examples.

EXAMPLES

Example 1

FIG. 1 is a block diagram showing configuration of a "recording-material type determination apparatus" according to a first example.

First, with reference to FIG. 1, description will be given of a control circuit block which performs first calculation and second calculation and determines the type of recording material.

In the figure, reference numeral 701 denotes a CPU which serves as a determination part, 702 denotes a control circuit, 703 denotes a CMOS area sensor, 704 denotes an interface control circuit, 705 denotes a calculation circuit, 706 denotes a register A which stores results of calculation on the amount of irregularities in the surface of recording material carried out by first calculation means (means of calculating the depth of irregularities in the surface of recording material), 707 denotes a register B which stores results of calculation on the edge amount of irregularities in the surface of recording material carried out by second calculation means (means of calculating the spacing of irregularities on the surface of recording material), 708 denotes a control register. Reference numeral 709 denotes a ROM (memory part) which pre-stores programs to be executed by the CPU 701 as well as reference information about various recording materials (described later).

Operation will be described next. When the CPU 701 instructs the control register 708 to operate the CMOS area sensor 703, the CMOS area sensor 703 starts picking up (taking) a picture of the recording material. In other words, the CMOS area sensor 703 starts to accumulate charge.

The CMOS area sensor 703 is selected at SL_select sent by the interface control circuit 704, SYSCLK is generated at a predetermined time, and digital image data picked up is transmitted by the CMOS area sensor 703 using an SL_out signal.

The imaging data received via the interface control circuit 704 is calculated by the calculation circuit 705 in the control circuit 702 using a first calculation method described later and the results are stored in the register A 706 as the amount of irregularities in the surface of the recording material.

The imaging data received via the interface control circuit 704 and calculated by the calculation circuit 705 in the control circuit 702 using a second calculation method described later is stored in the register B 707 as the edge amount of irregularities in the surface of the recording material. The CPU 701 judges the type of recording material based on the values of the two registers A and B.

Next, the CMOS area sensor 703 serving as an image sensor will be described with reference to FIG. 2.

In the figure, reference numeral 30 denotes a sensor unit, 31 denotes a recording-paper convey guide, 32 denotes recording material, 33 denotes an LED serving as lighting means, 34 denotes a CMOS area sensor, and 35 and 36 denote lenses.

Light from the LED light source illuminates the surface of the convey guide 31 or the surface of the recording material 32 via the lens 35.

Reflected light from the recording material 32 is collected via the lens 36 and is focused onto the CMOS area sensor 34 to allow a surface image to be read from the recording-paper convey guide 31 or recording material 32. At this time, the LED 33 is placed in such a way that its light will fall on the surface of the recording material at an oblique angle as shown in the figure.

Reference numerals 43 to 45 in FIGS. 3A to 3F denote images resulting from digital processing of surface images read by the 8×8 pixels CMOS area sensor 34 from the recording material. The digital processing consists of converting analog output of a sensor part of the CMOS area sensor 34 into 8-bit pixel data by means of A/D conversion.

5

Reference numeral **40** denotes recording material A, so-called rough paper, whose surface fibers are relatively rough. Reference numeral **41** denotes recording material B, so-called plain paper, which is in common use. Reference numeral **42** denotes an enlarged view of a surface of recording material C, so-called gloss paper, whose fibers have been compressed adequately. These images, after being read by the CMOS area sensor and subjected to digital processing, result in the images **43** to **45**.

In this way, surface images vary with the type of recording material. This is caused by differences in surface conditions of paper fibers. Specifically, raised fibers cast shadows when the paper surface is illuminated at an oblique angle whereas smooth fibers do not. The video images **43** to **45** are obtained as a result of this phenomenon.

Next, with reference to FIG. 4, description will be given of how the calculation circuit **705** as first calculation means calculates the depth of irregularities in the surface of recording material (hereinafter referred to simply as the amount of irregularities). In FIG. 4, reference numeral **50** denotes an image obtained by digitally processing a video image of the surface of the recording material.

Analog data outputted from the sensor part of the CMOS area sensor is converted into 8-bit pixel data by means of A/D conversion. The 8-bit data is determined in proportion to the brightness of the image.

Reference numeral **51** denotes the darkest part in the first line of the 8×8 pixels. Its value is '80'h in the example of FIG. 4. Reference numeral **52** denotes the brightest part in the first line of the 8×8 pixels. Its value is '10'h in the example of FIG. 4. The difference between the two values is '80'h-'10'h='70'h.

Thus, the difference (contrast) between the maximum value and minimum value in the first line is '70'b.

Similarly, reference numeral **53** denotes the darkest part in the second line. Its value is '80'b. Reference numeral **54** denotes the brightest part in the second line. Its value is '20'h. The difference is '80'h-'20'b='60'h.

Reference numeral **55** denotes the darkest part in the eighth line. Its value is '80'h. Reference numeral **56** denotes the brightest part in the eighth line. Its value is '10'h. The difference is '80'h-'10'h='70'h.

The difference between the maximum value and minimum value is added for each line and the resulting value for all the lines is defined as the result of the calculation carried out by the first calculation means on the amount of irregularities in the surface of the recording material.

Next, with reference to FIG. 5, description will be given of how the calculation circuit **705** as second calculation means calculates the spacing of irregularities on the surface of the recording material (edge amount).

Reference numeral **50** denotes an image obtained by digitally processing the surface of the recording material. Reference numeral **60** denotes an image obtained by binarizing 8×8 pixels picked up at the next sampling time using, as a threshold, an average calculated from the image **50** picked up beforehand at the previous sampling time.

Edge numbers obtained as a result of binarization are as follows. Reference numeral **61** denotes the edge number in the first line, which is '05'h in this example. Reference numeral **62** denotes the edge number in the second line, which is '03'h in this example.

Similarly, reference numeral **63** denotes the edge number in the eighth line, which is '03'h in this example.

The edge number is counted for each line and the resulting value for all the lines is defined as the result of the calculation

6

tion carried out by the second calculation means on the edge amount on the surface of the recording material.

Incidentally, the edge amount of irregularities is inversely proportional to the spacing of irregularities and in this example, information about the spacing of irregularities is obtained by calculating the edge amount.

The CMOS area sensor **703** will be described with reference to FIG. 6.

FIG. 6 is a block diagram showing configuration of the CMOS area sensor **703**. In the figure, reference numeral **601** denotes a CMOS area sensor part where, for example, sensors for 8×8 pixels are arranged in a matrix. Reference numerals **602** and **603** denote vertical shift registers, **604** denotes an output buffer, **605** denotes a horizontal shift register, **606** denotes a system clock, **607** denotes a timing generator.

Operation will be described next. When an SL_select signal **613** becomes active, the CMOS sensor part **601** starts accumulating charge based on received light. Next, when the system clock **606** is generated, the vertical shift registers **602** and **603** sequentially select columns of pixels to be read based on the timing generator **607** and put the data in the output buffer **604** in sequence.

The data placed in the output buffer **604** is transferred to an A/D converter **608** by the horizontal shift register **605**. After digital conversion by the A/D converter **608**, resulting pixel data is controlled with predetermined timing by an output interface circuit **609** and outputted as the SL_out signal **610** during a period when the SL_select signal **613** is active.

On the other hand, a control circuit **611** can control A/D conversion gain variably using an SL_in signal **612**. For example, if contrast of an image is not available, the CPU **701** can pick up the image always using the best contrast by changing gain.

Next, with reference to FIG. 7, description will be given of how the CPU **701** determines the type of recording material based on two register values.

FIG. 7 is a diagram showing distribution of recording materials together with video images of their actual surfaces, wherein the horizontal axis represents the value of the register A, i.e., the result of calculation carried out by the first calculation means on the amount of irregularities in the surface of the recording material while the vertical axis represents the value of the register B, i.e., the result of calculation carried out by the second calculation means on the edge amount of irregularities in the surface of the recording material.

Reference numeral **801** denotes gloss paper, **802** denotes plain paper, **803** denotes rough paper, and **804** denotes OHT.

As shown in the figure, in the case of the gloss paper **801**, which has high surface flatness, the value of the register A is small and the value of the register B is large.

In the case of the plain paper **802**, the value of the register A is larger than that of the gloss paper **801** and the value of the register B is smaller than that of the gloss paper **801** as can be seen from the video image of its surface.

Similarly, the rough paper **803** has a larger register A value than the plain paper **802** and a smaller register B value than the plain paper **802**.

On the other hand, since OHT is transparent, the black convey guide located below the OHT produces a dark image. Consequently, the values of both register A and register B are small and OHT occupies the position shown in FIG. 7.

Prescribed reference information about the amount of irregularities and the edge amount of irregularities of each

recording material is prestored in the ROM (memory unit) **709** shown in FIG. **1**. The CPU **701** reads the value stored in the register A and value stored in the register B in sequence by sending a read signal to the control register and then determines the type of recording material by comparing these values with the reference information stored in the ROM (memory unit) **709**.

In this way, the CPU **701** can detect surface characteristics, etc, of various recording materials by comparing the value of the register A, i.e., the result of calculation carried out by the first calculation means on the amount of irregularities in the surface of the recording material and the value of the register B, i.e., the result of calculation carried out by the second calculation means on the edge amount of irregularities on the surface of the recording material with the information stored in the ROM (memory unit) **709**. Thus, it can determine recording material by distinguishing among gloss paper, plain paper, rough paper and OHT.

In particular, the use of the edge amount of irregularities makes it possible to distinguish between the gloss paper **801** and OHT **804**.

Example 2

FIG. **8** is a sectional view showing configuration of an "image forming apparatus" according to a second example. The recording-material type determination apparatus used in this example is the same as the first example, and thus its description will be quoted.

In FIG. **8**, reference numeral **101** denotes an image forming apparatus; **102** denotes a paper cassette; **103** denotes a paper feeding roller; **104** denotes a transferring-belt driving roller; **105** denotes a transferring belt; **106** to **109** denote yellow, magenta, cyan and black photosensitive drums; **110** to **113** denote transferring rollers; **114** to **117** denote yellow, magenta, cyan and black cartridges; **118** to **121** denote yellow, magenta, cyan and black optical units; and **122** denotes a fixing unit.

Using an electrophotographic process, the image forming apparatus according to this example transfers yellow, magenta, cyan and black images onto recording paper by superimposing them and thermally fixes the toner images by a fixing roller under temperature control.

The optical units for individual colors scan the respective photosensitive drums by exposing their surface to a laser beam to form latent images. These scanning operations for forming images are synchronized so that images will be transferred from preset positions on conveyed recording paper.

Furthermore, the image forming apparatus comprises a paper feeding motor which feeds and conveys recording paper which is a recording material, transferring-belt driving motor which drives the transferring-belt driving roller, photosensitive-drum driving motor which drives the photosensitive drums for color inks and transferring roller, and fixing-roller driving motor which drives the fixing roller.

Reference numeral **123** denotes an image sensor which illuminates the surface of recording paper being fed and conveyed, collects and focuses the light reflected from the surface, and thereby detects an image of a specific area on the recording paper.

A control CPU (not shown) mounted on the image forming apparatus fuses and fixes the toner images on the recording paper by giving a desired quantity of heat to the recording paper using the fixing unit (part) **122**.

Next, operation of the control CPU will be described with reference to FIG. **9**.

FIG. **9** shows composition of units (parts) controlled by the control CPU. In the figure, reference numeral **10** denotes a CPU; **11** denotes a CMOS sensor; **12** to **15** denote optical units which are equipped with a polygon mirror, motor and laser, and paint desired latent images by scanning the surfaces of photosensitive drums with a laser; **16** denotes a paper feeding motor which feeds recording paper; **17** denotes a paper feeding solenoid used to start a paper feeding roller for feeding recording material; **18** denotes a paper detecting sensor which detects whether or not recording material is placed in position; **19** denotes a high voltage power supply which controls primary electrification, developing, primary transfer and a secondary transfer bias needed for an electrophotographic process; **20** denotes a drum driving motor which drives the photosensitive drums and transferring roller; **21** denotes a belt driving motor which drives the transferring bell and fixing unit roller; and **22** denotes a fixing unit and low voltage power supply unit which monitors temperature and keeps fixing temperature constant using a thermistor (not shown) under the control of the control CPU. Besides, reference numeral **24** denotes a ROM (memory unit) which prestores programs to be executed by the CPU **10** as well as reference information about various recording materials.

Reference numeral **23** denotes an ASIC which controls the speed of motors in the CMOS sensor **11** and optical units **12** to **15** as well as the speed of the paper feeding motor under instructions from the control CPU **10**.

To control the speed of the motors, tack signals from a motor (not shown) are detected and acceleration signals or deceleration signals are output to the motors such that the interval between the tack signals has a predetermined duration. Thus, it is advantageous to implement the control circuit as a hardware circuit using the ASIC **23** in that control loads on the CPU **10** can be reduced.

Upon receiving a print command from a host computer (not shown), the control CPU **10** makes the paper detecting sensor **18** judge whether or not recording material is present. If paper is present, the control CPU **10** drives the paper feeding motor **16**, drum driving motor **20**, belt driving motor **21** and paper feeding solenoid **17** to convey the recording material into position.

When the recording material is conveyed to the CMOS sensor **11**, the control CPU **10** instructs the ASIC **23** to make the CMOS sensor **11** pick up an image (taking a picture of a surface). Consequently, the CMOS sensor **11** picks up a surface image of the recording material.

In so doing, the ASIC **23** sets SL_select (see FIG. **1**) active, outputs a predetermined SYSCLK pulse at a predetermined time, and captures imaging data outputted from the CMOS sensor **11** using SL_out.

The gain of the CMOS sensor **11** is set as follows. When the control CPU **10** sets a predetermined value in a register in the ASIC **23**, the ASIC **23** sets SL_select active, outputs a predetermined SYSCLK pulse at a predetermined time, and sets the gain of the CMOS sensor **11** using SL_in.

The ASIC **23** comprises circuits which serve as the first calculation means and the second calculation means described in the first example and calculation results produced by them are stored in registers in the ASIC **23**.

The CPU **10** reads the registers in the ASIC **23**, determines the type of the recording material which has been fed, and variably controls developing-bias conditions of the high voltage power supply **19** according to the determined type.

For example, if the recording material used is so-called rough paper whose surface fibers are relatively rough, the

CPU **10** sets the developing bias to a lower value than in the case of plain paper to prevent scattering of toner by reducing the amount of toner sticking to the surface of the recording material. This is done to solve the problem of degradation in image quality caused by toner scattering from paper fibers especially in the case of rough paper whose surface tend to collect a large amount of toner.

Also, the CPU **10** determines the type of the recording material which has been fed, and variably controls transfer conditions of transferring means according to the determined type.

Also, the CPU **10** determines the type of the recording material which has been fed, and variably controls temperature conditions of the fixing unit **22** according to the determined type.

Especially in the case of OHT, this is effective in dealing with the problem that low fixability of the toner sticking to the recording material lowers the transparency of OHT.

Furthermore, the CPU **10** determines the type of the recording material which has been fed, and variably controls the conveying speed of the recording material according to the determined type. The variable control of the conveying speed is achieved as the CPU **10** sets the value of a speed control register in the ASIC **23**.

Especially in the case of OHT or gloss paper, this is effective in increasing the fixability of the toner which sticks to the recording material, improving gloss, and thereby improving image quality.

Thus, according to this example, the ASIC-based hardware circuit performs first calculation and second calculation based on the surface image of the recording material picked up by the CMOS area sensor, and the CPU variably controls the developing conditions and transfer conditions of the high voltage power supply, controlled-temperature conditions of the fixing unit, or conveying speed of the recording material based on the calculation results.

Example 3

FIG. **10** is diagram showing composition of units controlled by a control CPU in an "image forming apparatus" according to a third example. The recording-material type determination apparatus used in this example is the same as the first example, and thus its description will be quoted.

In FIG. **10**, reference numeral **24** denotes a digital signal processor. Reference numerals **11** to **22** denote the same components as those described in the second example, and thus description thereof will be omitted.

In this example, instead of the control CPU described in the second example, the digital signal processor (DSP) directly controls the image forming apparatus including motors as well as imaging information from the CMOS area sensor.

Recently, the performance of DSPs has been improved greatly. This has enabled real-time control including motor control as well as high-speed arithmetic processing of imaging information from CMOS area sensors, using a single DSP chip.

The image captured by the CMOS area sensor **11** is processed by the DSP **24** using the first calculation means and the second calculation means. Consequently, the DSP **24** variably controls control conditions of the high voltage power supply **19**, fixing unit **22**, drum driving motor **20** and belt driving motor **21**.

This makes it possible to simplify and downsize the control circuit of the image forming apparatus. Also, DSP-based

software control makes it possible to adjust calculation methods of the first calculation means and second calculation means flexibly.

For example, any contamination of the CMOS area sensor **11** or its lens with dust or other foreign matter may degrade the accuracy with which the surface characteristics of recording material are detected based on results of calculations carried out by the first calculation means and second calculation means.

The above problem can be solved by picking up an image of the recording material as a reference image before the recording material passes through the CMOS area sensor **11** and subtracting the reference image from a surface image of the recording material.

In this way, taking full advantage of the flexibility of DSP-based control, image forming apparatus according to this example can greatly improve the accuracy with which the type and surface characteristics of recording material are detected based on the calculations carried out by the first calculation means and second calculation means.

As described above, the present invention provides a recording-material type determination apparatus and recording-material type determination method which can determine the type of recording material using simple calculations as well as provides an image forming apparatus capable of obtaining stable image quality independent of the type of recording material using the apparatus and method. Also, since the present invention determines the type of recording material from two standpoints—namely, depth of irregularities in the surface of the recording material and spacing of irregularities on the surface of the recording material, it can determine the type of recording material more accurately.

The present invention has been described above citing a few preferred examples, but the present invention is not limited to these examples and it will be apparent that various modifications and applications are possible within the scope of the appended claims.

What is claimed is:

1. A recording-material type determination apparatus comprising:

a light emit unit, adapted to illuminate a surface of recording material;

a read unit, adapted to read an illuminated region on the surface of the recording material as a video image;

a first calculation part adapted to calculate information about depth of irregularities in the surface of the recording material based on video information read by the read unit;

a second calculation part adapted to calculate information about spacing of irregularities on the surface of the recording material based on the video information read by the read unit; and

a determination part adapted to determine a type of recording material based on calculation results produced by the first calculation part and the second calculation part.

2. A recording-material type determination apparatus according to claim **1**, wherein the read unit is an area sensor including a plurality of pixels.

3. A recording-material type determination apparatus according to claim **1**, wherein the read unit outputs a video image of the surface of the recording material as digital values.

4. A recording-material type determination apparatus according to claim **1**, wherein the first calculation part quan-

11

titatively determines the depth of irregularities in the surface of the recording material by extracting a maximum value of contrast difference among pixels in a specific pixel region, from video information picked up by the read unit.

5 5. A recording-material type determination apparatus according to claim 1, wherein the second calculation part quantitatively determines the spacing of irregularities on the surface of the recording material by binarizing video information about pixels in a specific pixel region in video information picked up by the read unit and counting edge numbers in a binarized image.

10 6. A recording-material type determination apparatus according to claim 1, comprising:

a memory part adapted to [prestore] *store reference* information about depth of irregularities and spacing of irregularities for each type of recording material,

15 wherein the determination part determines the type of recording material by comparing the calculation results produced by the first calculation part and the second calculation part with *the reference* information stored in the memory unit.

20 7. A recording-material type determination apparatus according to claim 1, wherein the first calculation part and the second calculation part consist of a DSP.

8. A recording-material type determination apparatus according to claim 1, wherein the determination part determines that the recording material is plain paper.

25 9. A recording-material type determination apparatus according to claim 1, wherein the determination part distinguishes whether the recording material is glossy paper or plain paper.

30 10. A recording-material type determination apparatus according to claim 1, wherein the determination part distinguishes whether the recording material is rough paper or plain paper.

35 11. A recording-material type determination apparatus according to claim 1, wherein the determination part distinguishes whether the recording material is OHT or plain paper.

12. A recording-material type determination apparatus comprising:

an input part adapted to input a video image of a surface of recording material;

40 a first calculation part adapted to calculate information about depth of irregularities in a surface of the recording material based on video information inputted in the input unit;

45 a second calculation part adapted to calculate information about spacing of irregularities on the surface of the recording material based on the video information inputted in the input unit; and

50 a determination part adapted to determine a type of recording material based on calculation results produced by the first calculation part and the second calculation part.

13. A recording-material type determination method comprising:

55 a read step of reading a surface of recording material as a video image;

a first calculation step of calculating information about depth of irregularities in the surface of the recording material based on results of the read step;

60 a second calculation step of calculating information about spacing of irregularities on the surface of the recording material based on the results of the read step; and

a determination step of determining a type of recording material based on calculation results produced in the first calculation step and the second calculation step.

65 14. A recording-material type determination method according to claim 13, wherein, in the read step, an area sensor including a plurality of pixels is used.

12

15. An image forming apparatus comprising:

a conveying part adapted to convey recording material;
an image forming part which forms an image on the recording material conveyed by the [conveyor] *conveying part*;

a light emit unit, adapted to illuminate a surface of recording material;

a read unit, adapted to read an illuminated region on the surface of the recording material as a video image;

10 a first calculation part adapted to calculate information about depth of irregularities in the surface of the recording material based on video information read by the read unit;

15 a second calculation part adapted to calculate information about spacing of irregularities on the surface of the recording material based on the video information read by the read unit; *and*

[a determination part adapted to determine a type of recording material based on calculation results produced by the first calculation part and the second calculation part; *and*]

20 a control part which controls image forming conditions of the image forming part based on [the type of recording material determined by the determination part] *calculation results produced by the first calculation part and the second calculation part*.

25 16. An image forming apparatus according to claim 15, wherein the image forming part comprises a developing part which develops a latent image on an image bearing member, a transferring part which transfers a visible image produced by the developing part to the recording material conveyed by the conveyor, and a fixing part which thermally fixes the visible image transferred to the recording material by the transferring part.

35 17. An image forming apparatus according to claim [15] 16, wherein the image forming conditions controlled by the [controller] *control part* include at least one of developing conditions of the developing part, transfer conditions of the transferring part and fixing temperature for the fixing part.

40 18. An image forming apparatus according to claim [15] 16, wherein an image forming condition controlled by the control part is speed at which the recording material passes through the fixing part.

19. *An image forming apparatus comprising:*

a conveying part adapted to convey recording material;

an image forming part which forms an image on the recording material conveyed by the conveying part;

a light emit unit, adapted to illuminate a surface of recording material;

a read unit, adapted to read an illuminated region on the surface of the recording material as a video image;

a first calculation part adapted to calculate information about depth of irregularities in the surface of the recording material based on video information read by the read unit;

a second calculation part adapted to calculate information about spacing of irregularities on the surface of the recording material based on the video information read by the read unit;

a determination part adapted to determine a type of recording material based on calculation results produced by the first calculation part and the second calculation part; and

a control part which controls image forming conditions of the image forming part based on the type of recording material determined by the determination part.