

US00RE41677E

(19) **United States**
(12) **Reissued Patent**
DeRose et al.

(10) **Patent Number:** **US RE41,677 E**
(45) **Date of Reissued Patent:** **Sep. 14, 2010**

(54) **HYBRID SUBDIVISION IN COMPUTER GRAPHICS**

FOREIGN PATENT DOCUMENTS

(75) Inventors: **Anthony David DeRose**, San Rafael, CA (US); **Michael Kass**, Berkeley, CA (US)

WO WO 89/07301 A1 8/1989
WO WO 89/07301989 * 8/1989
WO WO 95/06291 * 3/1995
WO WO 95/06291 A1 3/1995

(73) Assignee: **Pixar**, Emeryville, CA (US)

OTHER PUBLICATIONS

(21) Appl. No.: **11/004,170**

(22) Filed: **Dec. 3, 2004**

Related U.S. Patent Documents

Reissue of:

(64) Patent No.: **6,489,960**
Issued: **Dec. 3, 2002**
Appl. No.: **09/756,112**
Filed: **Jan. 9, 2001**

U.S. Applications:

(

(63) Continuation of application No. 08/905,436, filed on Aug. 4, 1997, now Pat. No. 6,300,960.

(51) **Int. Cl.**
G06T 17/20 (2006.01)
G06T 15/70 (2006.01)

(52) **U.S. Cl.** **345/423**; 345/428

(58) **Field of Classification Search** None
See application file for complete search history.

(56) **References Cited**

U.S. PATENT DOCUMENTS

5,083,262 A * 1/1992 Haff, Jr. 703/27
5,179,647 A * 1/1993 Chang 345/442
5,602,979 A * 2/1997 Loop 345/423
5,929,860 A * 7/1999 Hoppe 345/419
5,963,209 A * 10/1999 Hoppe 345/419
5,966,133 A * 10/1999 Hoppe 345/420
6,078,331 A * 6/2000 Pulli et al. 345/423
6,130,673 A * 10/2000 Pulli et al. 345/428
6,222,532 B1 4/2001 Ceccarelli

Kari Pulli and Mark Segal, "Fast Rendering of Subdivision Surfaces," Mar. 1996, Technical Report UW-CSE-96-03-02, University of Washington, pp. 1-11.*
Mark Halstead, Michael Kass, Tony DeRose, "Efficient, Fair Interpolation using Catmull-Clark Surfaces," Sep. 1993, Proceedings of the 20th Annual Conference on Computer Graphics and Interactive Techniques, p. 35-44.*
Maneesh Agrawala, Andrew C. Beers, Marc Levoy, "3D Painting on Scanned Surfaces," Apr. 9, 1995, Proceedings of the 1995 Symposium on Interactive 3D Graphics, p. 145-150.*
Kari Pulli and Michael Lounsbery, "Hierarchical editing of subdivision surfaces," Apr. 1997, Technical Report UW-CSE-97-04-07, University of Washington.*
Jean E. Schweitzer, "Analysis and Application of Subdivision Surfaces", Aug. 2, 1996, University Department of Computer Science and Engineering, University of Washington, Technical Report UW-CSE-96-08-02, p. 31-86.*
Hugues Hoppe, Tony DeRose, Tom Duchamp, Mark Halstead, Hubert Jin, John McDonald, Jean Schweitzer and Werner Stuetzle, "Piecewise Smooth Surface Reconstruction," 1994, Computer Graphics, vol. 28, p. 295-302.*

(Continued)

Primary Examiner—Ulka Chauhan
Assistant Examiner—Jason M Repko
(74) *Attorney, Agent, or Firm*—Townsend and Townsend and Crew LLP; Gerald T. Gray

(57) **ABSTRACT**

Different limit surfaces are derived from the same initial arbitrary polygon mesh by sequentially combining different subdivision rules. This added freedom allows for the more efficiently modeling of objects in computer graphics including objects and characters with semi-sharp features.

39 Claims, 12 Drawing Sheets

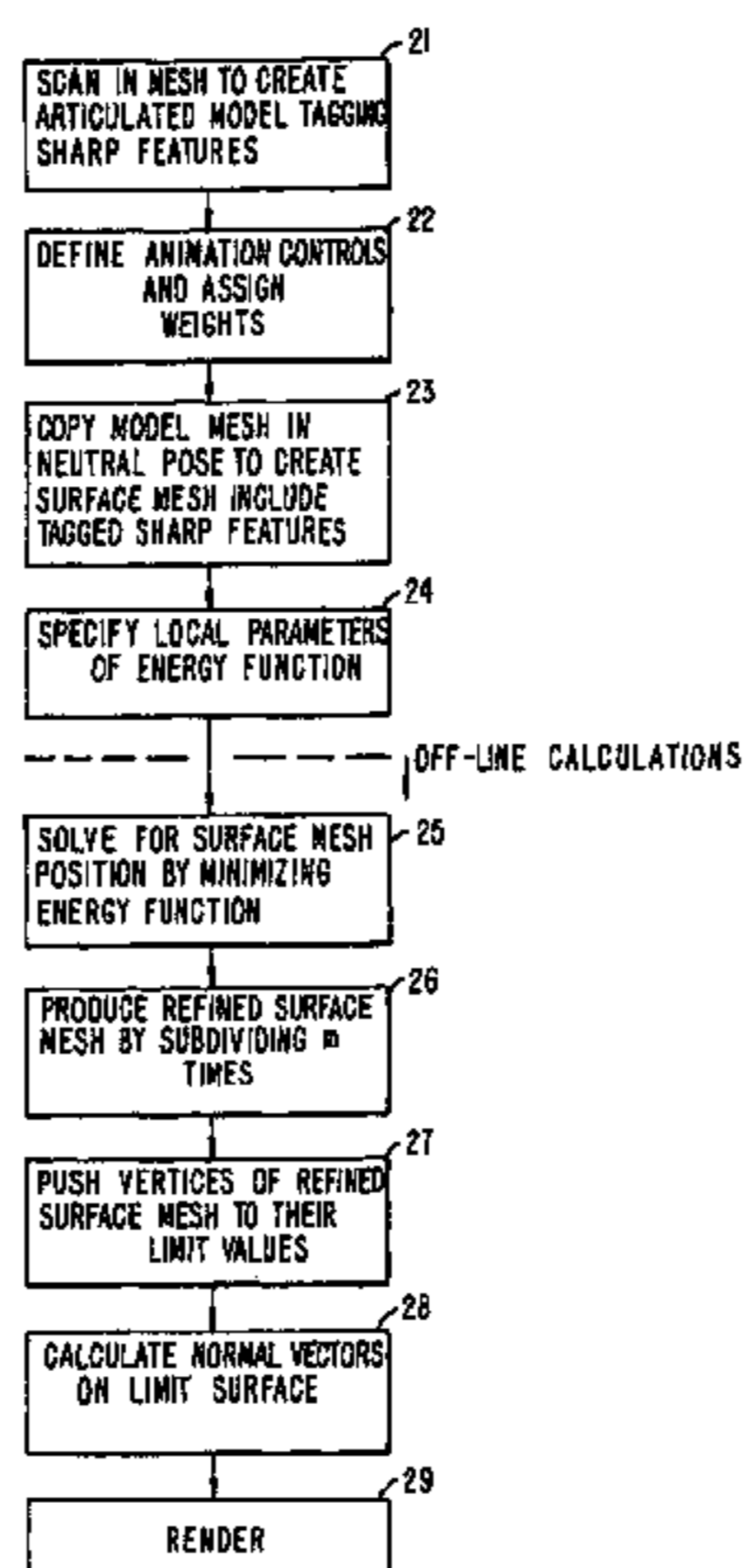

OTHER PUBLICATIONS

- Bajaj, C.L. et al., "Automatic Reconstruction of Surfaces and Scalar Fields From 3D Scans," *Computer Graphics (SIGGRAPH '95 Conference Proceedings)*, pp. 109–118 (1995).
- Bajaj, C.L. et al., "Adaptive Reconstruction of Surfaces and Scalar Fields From Dense Scattered Trivariate Data," *Computer Science Technical Report*, pp. 1–19 (1995).
- Ball, A.A. et al., "A Matrix Approach to the Analysis of Recursively Generated B-Spline Surfaces," *Computer-Aided Design*, 18–437–442 (1986).
- Ball, A.A. et al., "Conditions for Tangent Plane Continuity Over Recursively Generated B-Spline Surfaces," *ACM Transactions on Graphics*, 7–83–102 (1988).
- Ball, A.A. et al., "An Investigation of Curvature Variations Over Recursively Generated B-Spline Surfaces," *ACM Transactions on Graphics*, 9–424–437 (1990).
- Brunet, P., "Including Shape Handles in Recursive Subdivision Surfaces," *Computer-Aided Geometric Design*, 5:1:41–50 (1988).
- Catmull, E. et al., "Recursively Generated B-Spline Surfaces on Arbitrary Topological Meshes," *Computer Aided Design*, 10:350–355 (1978).
- Certain, A. et al., "Interactive Multiresolution Surface Viewing," *Computer Graphics (SIGGRAPH 96 Conference Proceedings)*, pp. 91–98 (1996).
- Chadwick, J.E. et al., "Critter Construction: Developing Characters for Computer Animation," *Proceedings of PIXIM 88*, pp. 283–306 (Oct. 24–28, 1988).
- Derfel, G. et al., "Generalized Refinement Equations and Subdivision Processes," Ben-Gurion University and Tel-Aviv University.
- Doo, D. et al., "Behavior for Recursive Division Surfaces Near Extraordinary Points," *Computer Aided Design*, 10:356–360 (1978).
- Dyn, N. et al., "Analysis of Asymptotically Equivalent Binary subdivision Schemes," School of Mathematical Sciences, Tel Aviv University.
- Dyn, N. et al., "Interpolating Subdivision Schemes for the Generation of Curves and Surfaces," *Multivariate Interpolation and Approximation*, W. Haussman et al., eds. Birkhauser, Veriga, Basel, pp. 91–106 (1990).
- Dyn, N. et al., "Analysis of Uniform Binary Subdivision Schemes for Curve design," *Constructive Approximation*, Springer-Verlag, New York Inc., 7:127–147 (1991).
- Dyn, N., "Subdivision Schemes in Computer-Aided Geometric Design," *Advances in Numerical Analysis*, vol. II, Clarendon Press, Oxford, pp. 36–104 (1992).
- Dyn, N. et al., "Subdivision Schemes for Surface Interpolation," Department of Mathematics, Tel Aviv University (1993).
- Eck, M. et al., "Automatic Reconstruction of B-Spline Surfaces of Arbitrary Topological Type," *Computer Graphics (SIGGRAPH 96 Conference Proceedings)*, pp. 325–334 (1996).
- Gudukbay, U. et al., "A Spring Force Formulation For Elastically Deformable Models," *Computers & Graphics*, 21:3:335–346 (May–Jun. 1997).
- Hahn, J.K., "Realistic Animation of Rigid Bodies," *Computer Graphics SIGGRAPH '88 Conference Proceedings*, 22:4:299–308 (Aug. 1–5, 1988).
- Hoppe, H. et al., "Piecewise Smooth Surface Reconstruction," *Computer Graphics (SIGGRAPH 94 Conference Proceedings)*, pp. 295–302 (1994).
- Hoppe, H., "Progressive Meshes," *Computer Graphics (SIGGRAPH 96 Conference Proceedings)*, pp. 99–108 (1996).
- Hoppe, H., *Computer Graphics (SIGGRAPH 97 Conference Proceedings)*, pp. 189–198 (Aug. 3–8, 1997).
- Ip, H.H.S. et al., "Dynamic Simulation of Human Hand Motion Using an Anatomical Correct Hierarchical Approach," *Computational Cybernetics And Simulation (1997 IEEE International Conference On Systems, Man and Cybernetics)*, vol. 2, pp. 1307–1312 (1997).
- Krishnamurthy, V. et al., "Fitting Smooth Surfaces to Dense Polygon Meshes," *Computer Graphics (SIGGRAPH 96 Conference Proceedings)*, pp. 313–324 (1996).
- Lee, Y. et al., "Realistic Modeling for Facial Animation," *Computer Graphics Proceedings, SIGGRAPH 1995, Annual Conference Series*, 1995, pp. 55–62.
- Lee, Y. et al., "Realistic Modeling for Facial Animation," *Computer Graphics (SIGGRAPH 95 Conference Proceedings)*, pp. 55–62 (1995).
- Nasri, A.H., "Polyhedral Subdivision Methods for Free-Form Surfaces," *ACM Transactions on Graphics*, 6:29–73 (1987).
- Nasri, A.H., "Boundary-Corner Control in Recursive-Subdivision Surfaces," *Computer Aided Design*, vol. 2, pp. 405–410 (1990).
- Nasri, A.H., "Surface Interpolation of Irregular Networks with Normal Conditions," *Computer Aided Geometric Design*, 8:89–96 (1991).
- Parke, F., "Parameterized Models for Facial Animation," *IEEE Computer Graphics and Applications*, pp. 61–68 (1982).
- Platt, S.M. et al., "Animating Facial Expressions," *Computer Graphics*, 15:245–252 (1981).
- Reif, U., "A Unified Approach to Subdivision Algorithms," Department of Mathematics University of Stuttgart.
- Turner, R. et al., "The Elastic Surface Layer Model for Animated Character Construction," *Communication With Virtual Worlds (Proceedings of Computer Graphics International '93)*, pp. 399–412 (Jun. 21–25, 1993).
- Warren, J., *Subdivision Methods for Geometric Design* (1994).
- Wilhelms, J. et al., "Anatomically Based Modeling," *Computer Graphics (SIGGRAPH 97 Conference Proceedings)*, pp. 173–180 (1997).
- PCT Written Opinion dated May 10, 1999 for International Application No. PCT/US98/15703.*
- Ip, Horace H.S. and C.S. Chan, "Dynamic Simulation of Human Hand Motion Using an Anatomical Correct Hierarchical Approach," *Computational Cybernetics And Simulation (1997 IEEE International Conference On Systems, Man and Cybernetics)* vol. 2 pp. 1307–1312 (1997) XP002084380.*
- International Search Report dated Nov. 27, 1998 for International Application No. PCT/US 98/15702 (International Filing Date: Jul. 29, 1998).*
- International Search Report dated Dec. 8, 1998 for International Application No. PCT/US 98/15703 (International Filing Date: Jul. 29, 1998).*
- International Search Report dated Nov. 4, 1998 for International Application No. PCT/US 98/15704 (International Filing Date: Jul. 29, 1998).*
- Hoppe, H., "Progressive Meshes," *Computer Graphics (SIGGRAPH 96 Conference Proceedings)*, pp. 99–108 (1996).*

* cited by examiner

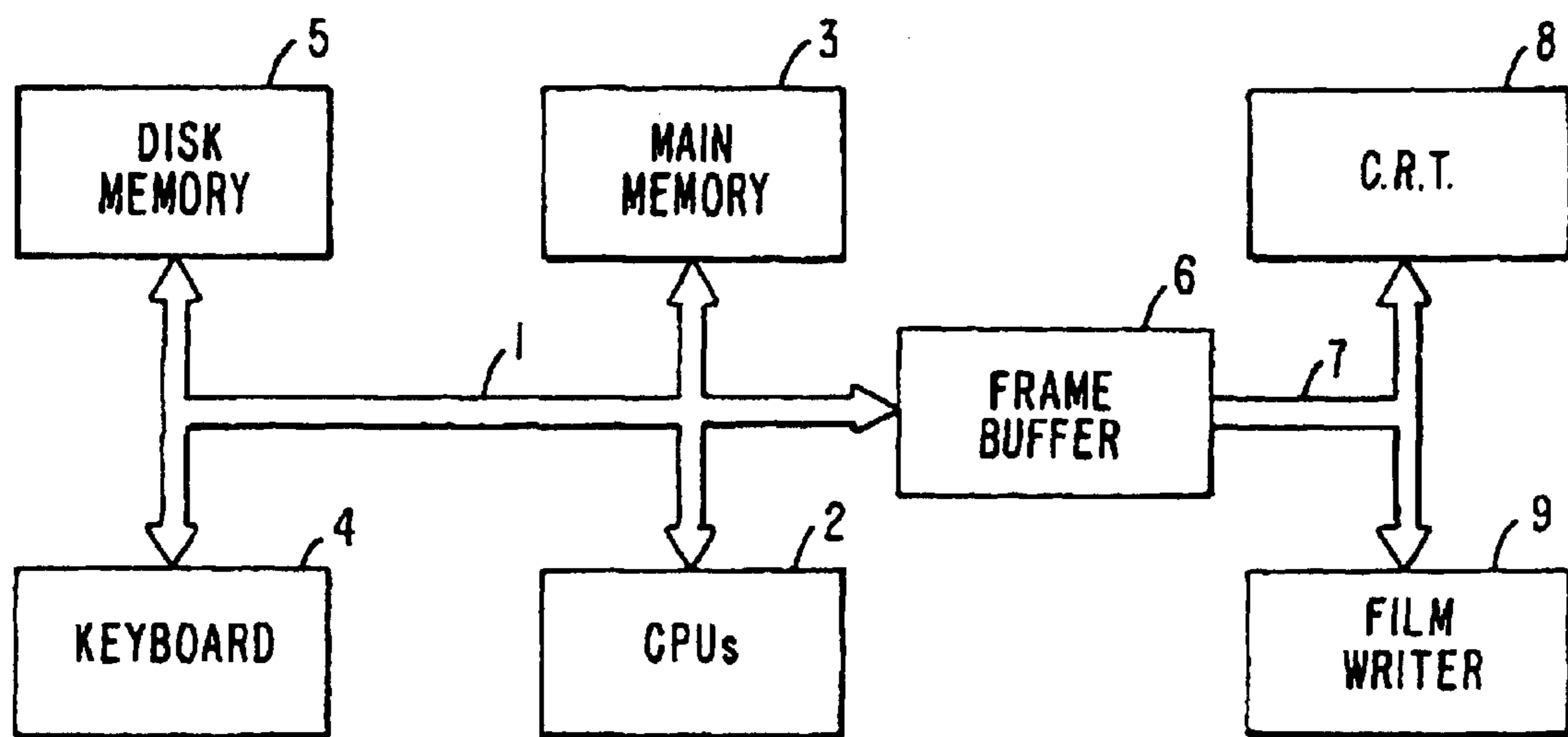

FIG. 1.

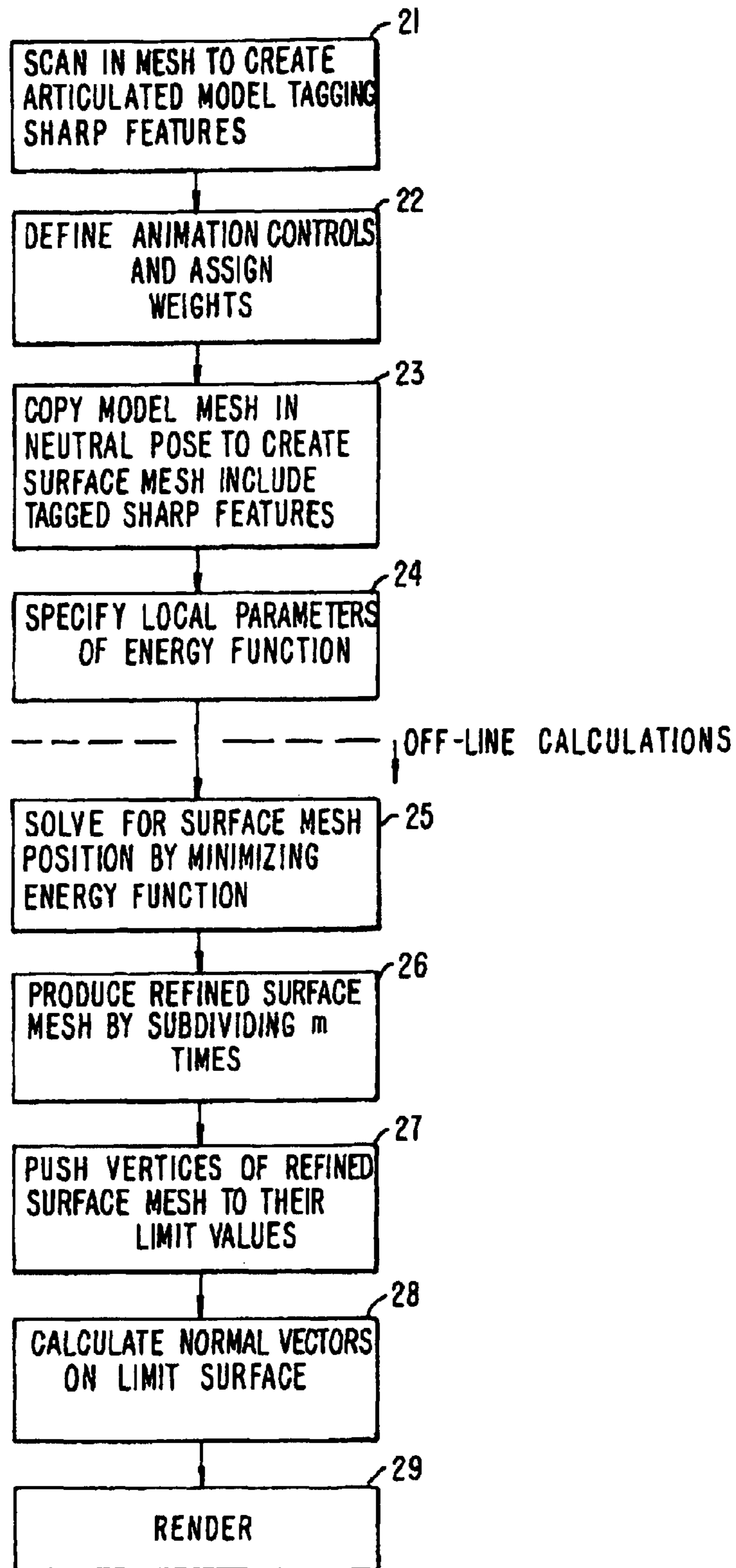

FIG. 2.

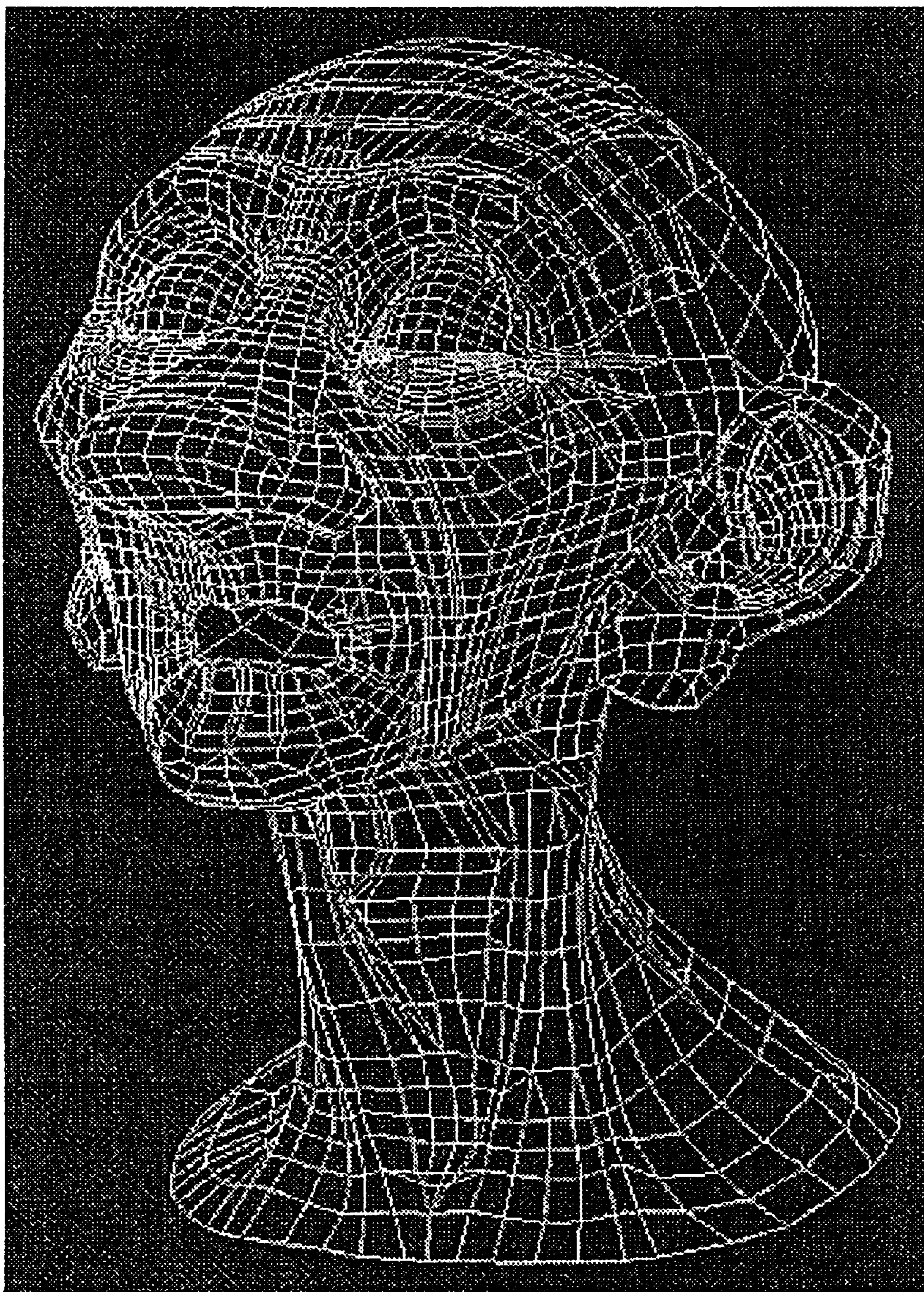

FIG. 3.

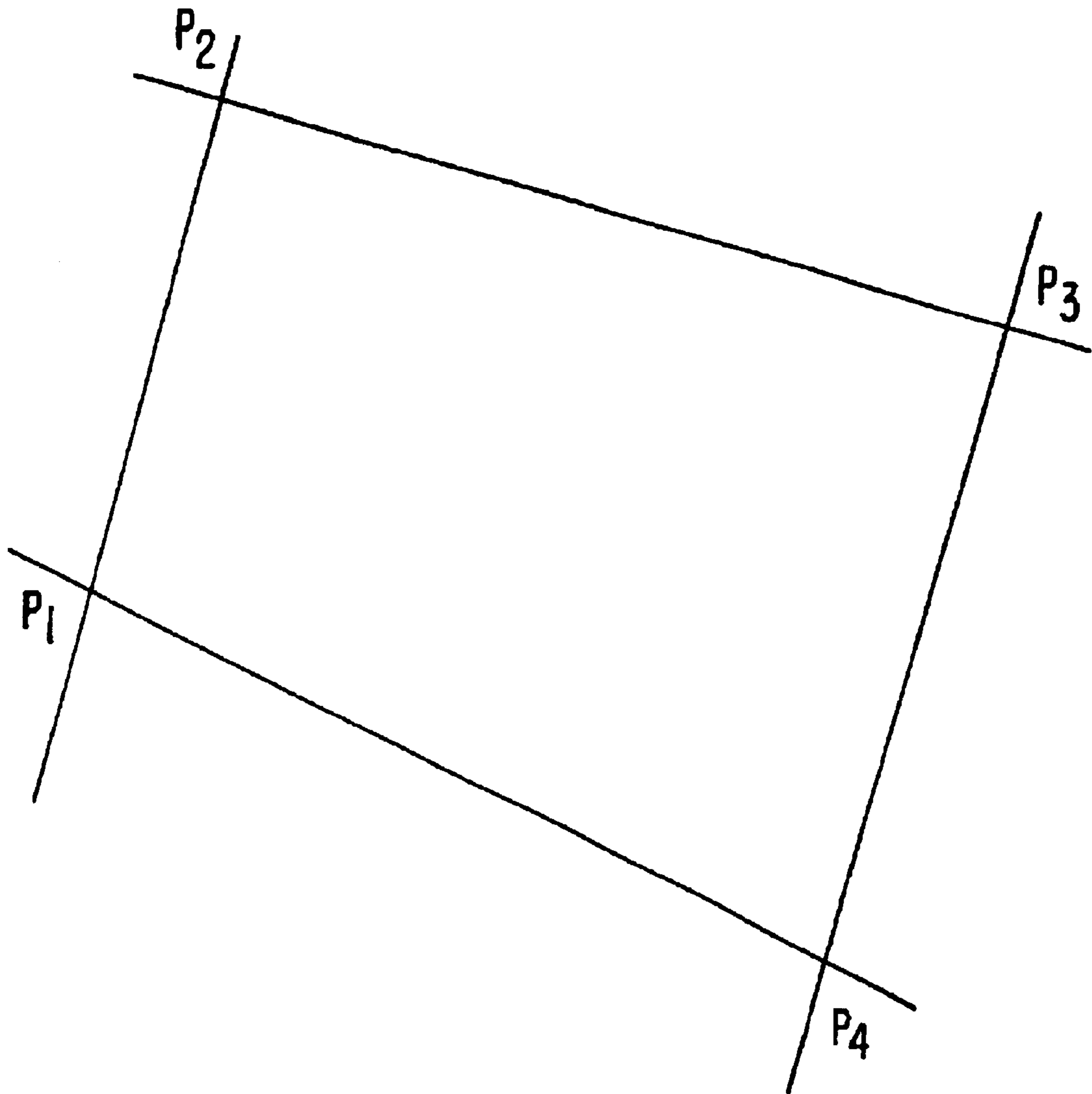

FIG. 4.



FIG. 5.

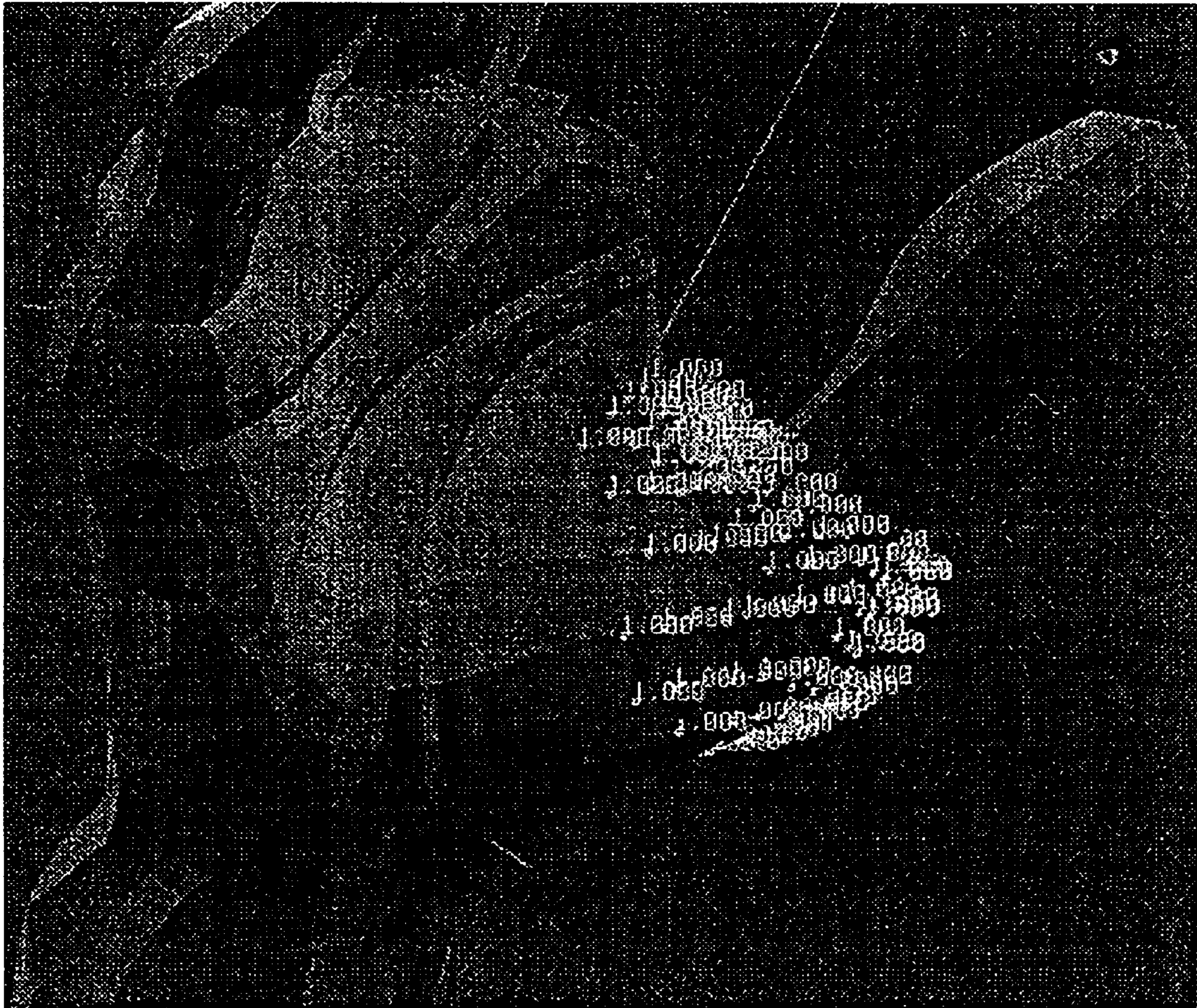

FIG. 6.

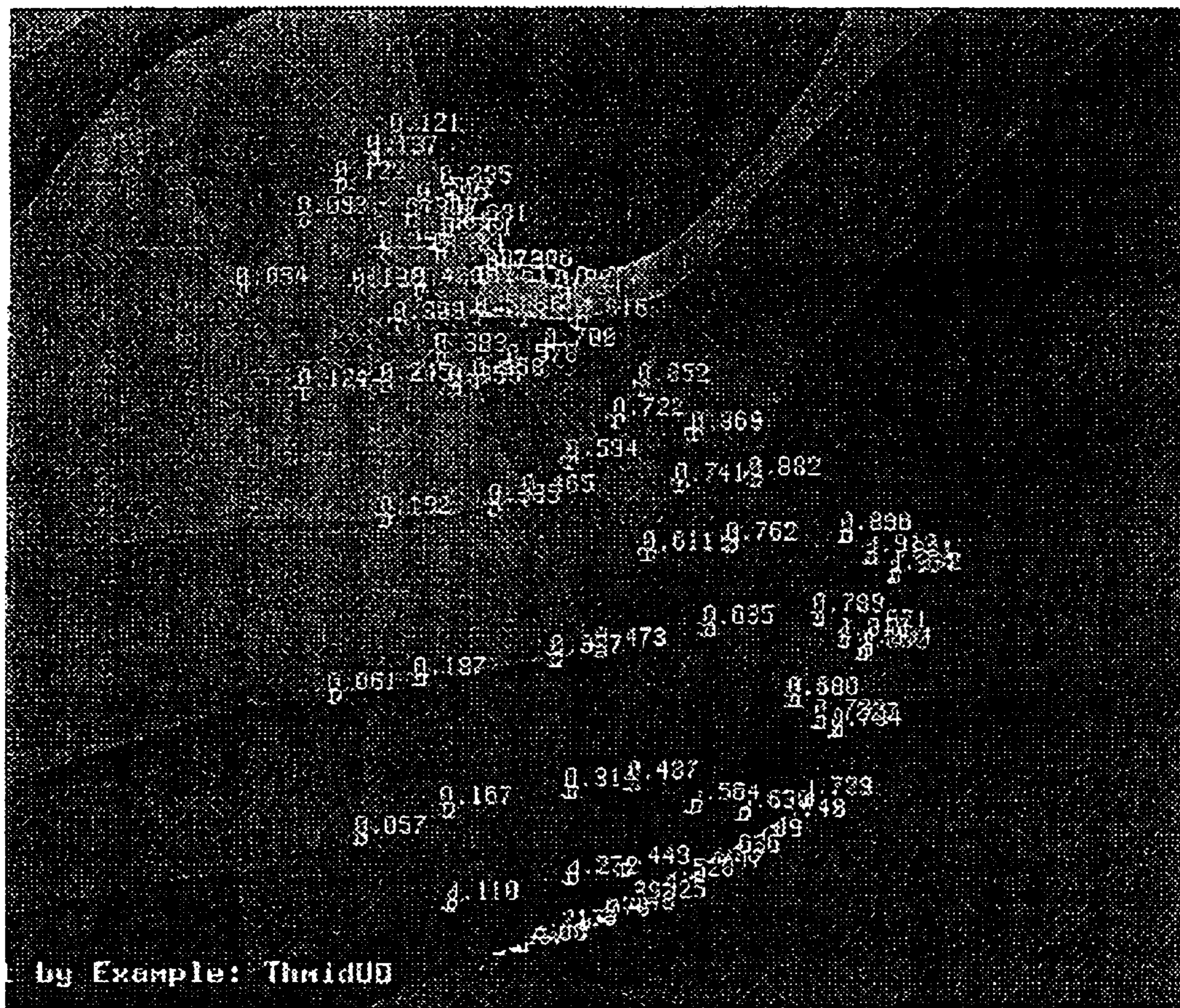

FIG. 7.

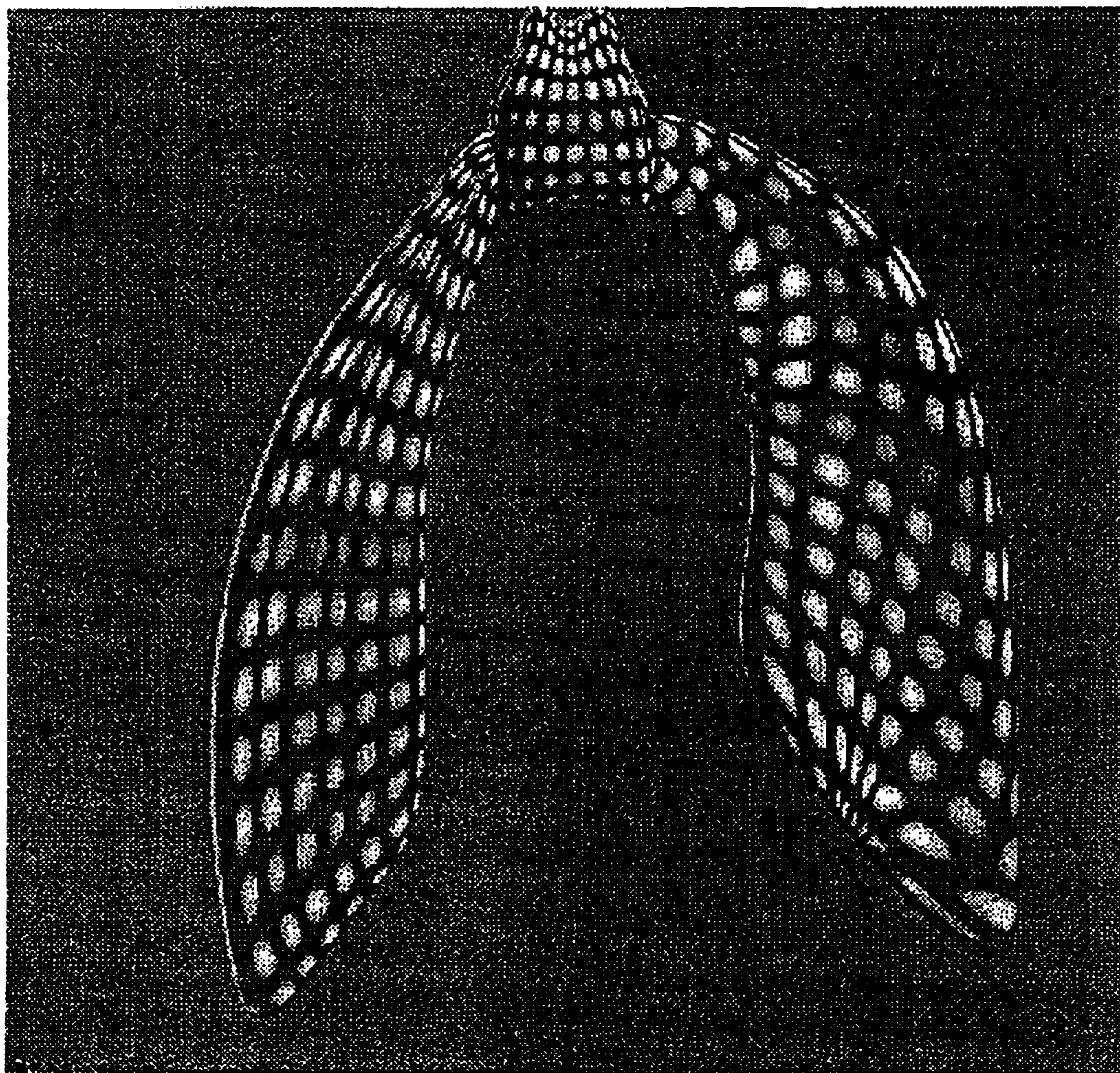

FIG. 8.

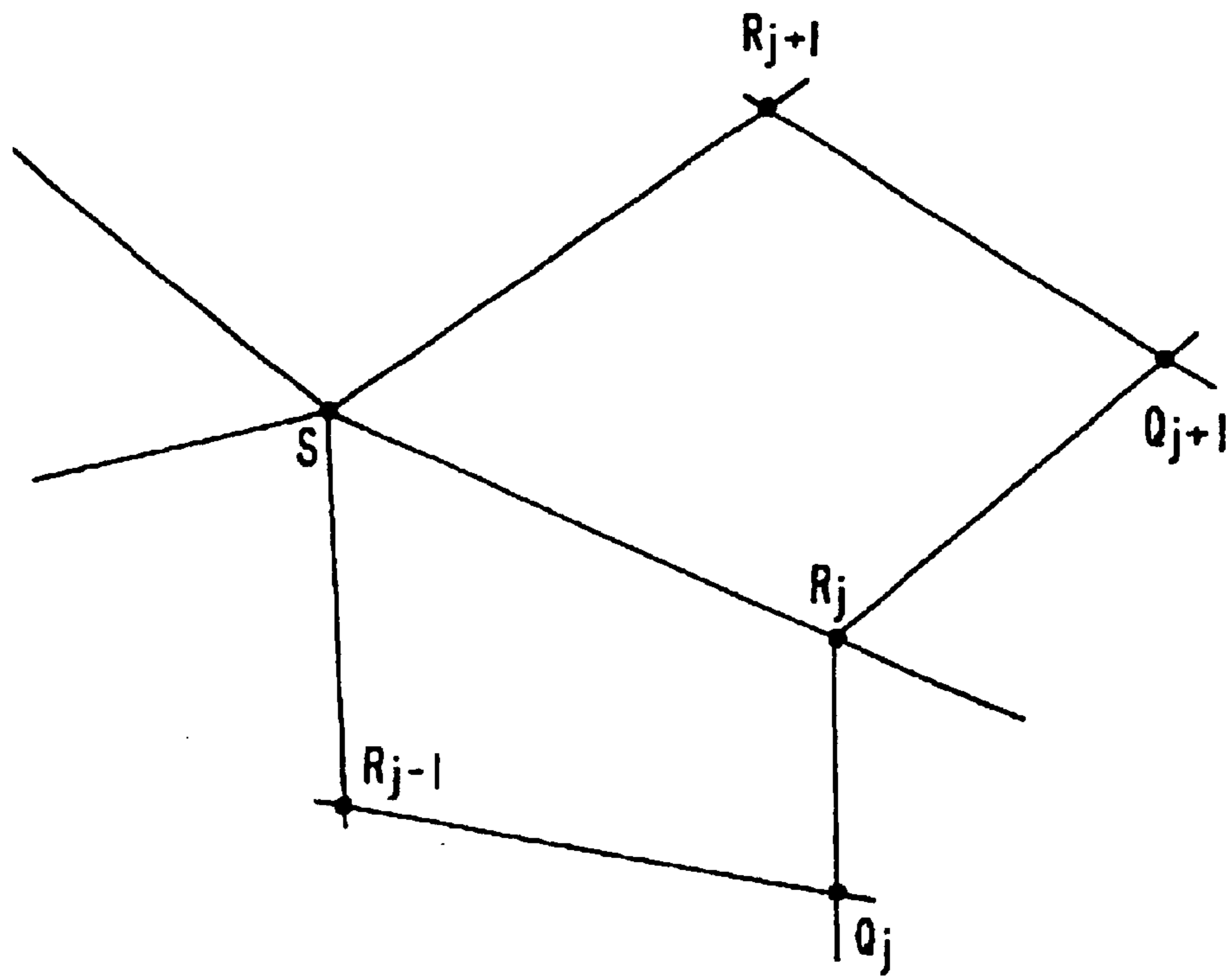

FIG. 9.

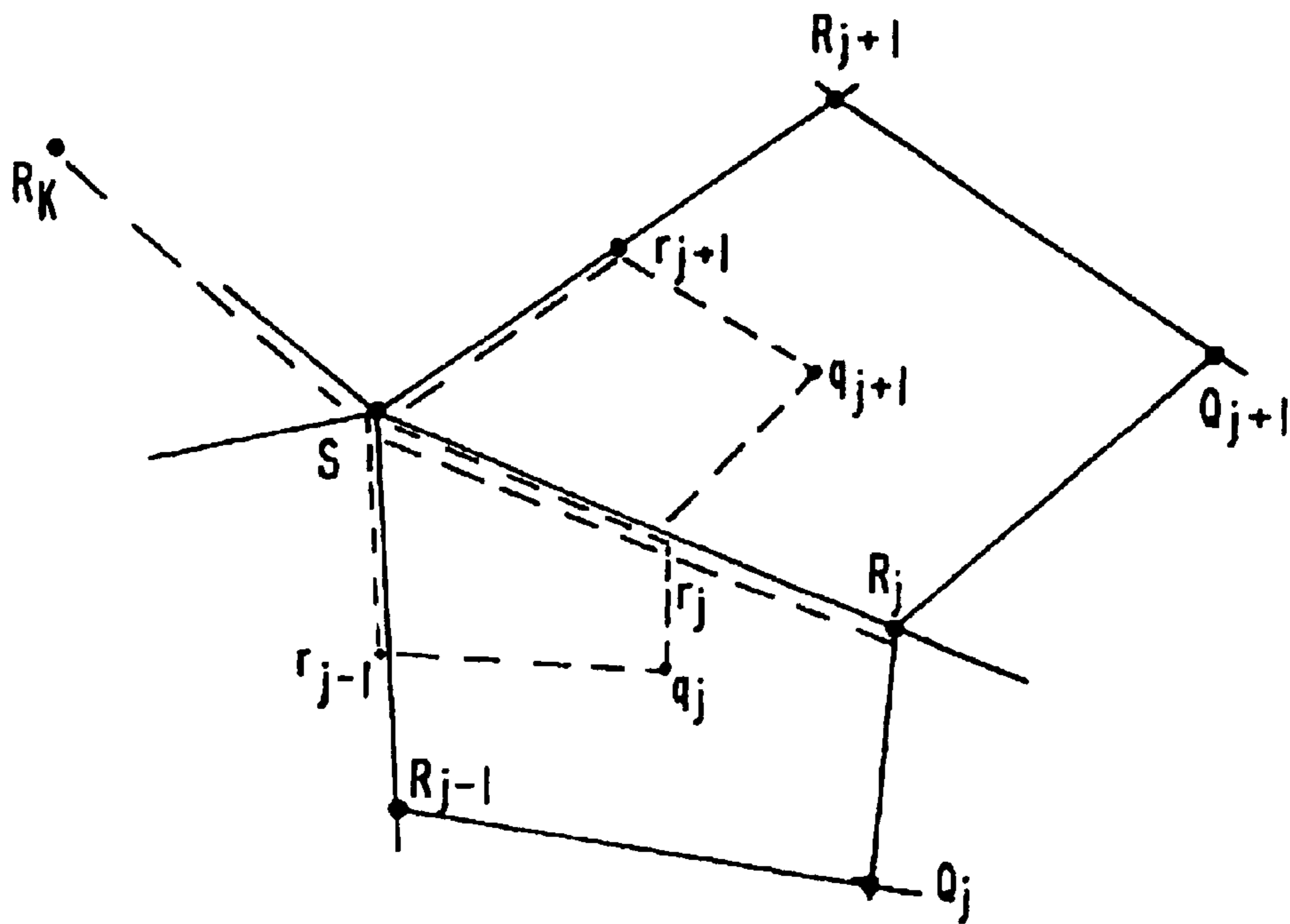

FIG. 10.

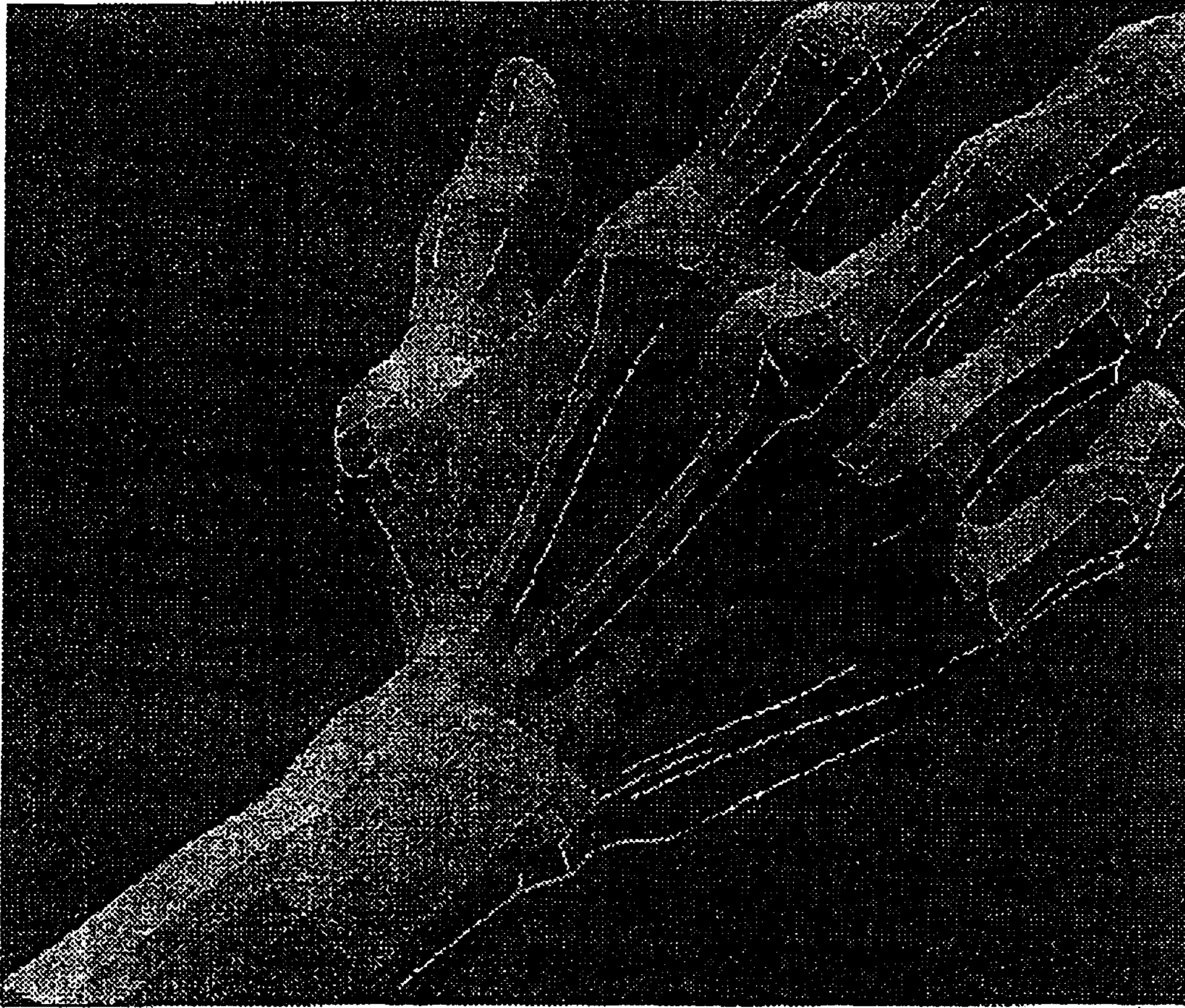

FIG. II.



FIG. 12.

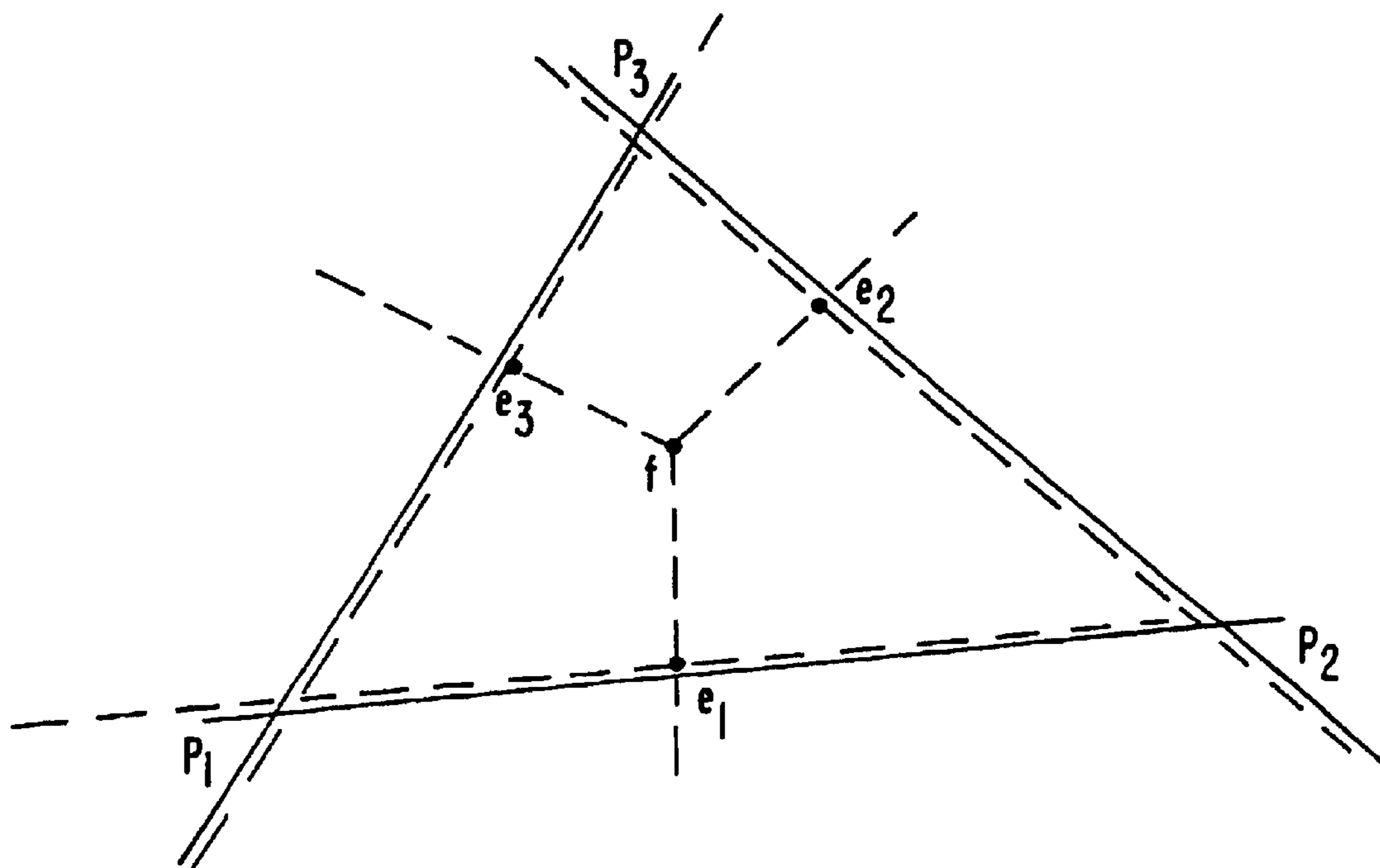

FIG. 13.

HYBRID SUBDIVISION IN COMPUTER GRAPHICS

Matter enclosed in heavy brackets [] appears in the original patent but forms no part of this reissue specification; matter printed in italics indicates the additions made by reissue.

This is a Continuation of application Ser. No. 08/905,436 filed Aug. 4, 1997 *now U.S. Pat. No. 6,300,960*. The disclosure of the prior application(s) is hereby incorporated by reference herein in its entirety.

CROSS-REFERENCE TO RELATED APPLICATIONS

The following co-pending U.S. Patent applications relate to the present application. Each of the listed co-pending applications is assigned to the same assignee as the present application.

1. U.S. patent application Ser. No. 08/905,436, filed Aug. 4, 1997 and titled: "REALISTIC SURFACE SIMULATION IN COMPUTER ANIMATION".

2. U.S. patent application Ser. No. 08/905,434 filed Aug. 4, 1997 and titled: "TEXTURE MAPPING AND OTHER USES OF SCALAR FIELDS ON SUBDIVISION SURFACES IN COMPUTER GRAPHICS AND ANIMATION".

FIELD OF THE INVENTION

The invention relates generally to the art of computer graphics and the modeling of objects. More particularly the invention relates to the modeling of objects using subdivision surfaces and to the modeling of objects with semi-sharp creases or edges.

BACKGROUND OF THE INVENTION

No real objects have perfectly sharp features. All edges, even those on seemingly sharp objects, have some finite radius of curvature. Though inevitable in real life, this unavoidable lack of precision presents a difficult problem for computer graphics and computer animation. Some modeling methods, e.g., the use of piecewise linear surfaces (polygon meshes) work well for objects with sharp boundaries. Other methods, e.g., NURBS (non-uniform rational B-splines) work well (i.e., are more accurate and compact) for modeling curved surfaces, but fair less well and are less efficient for modeling objects with sharp features.

In recent work, Hoppe, et al. have shown that piecewise smooth surfaces incorporating sharp features, including edges, creases, darts and corners, can be efficiently modeled using subdivision surfaces by altering the standard Loop subdivision rules in the region of such sharp features. Hoppe, et al., Piecewise Smooth Surface Reconstruction, Computer Graphics (SIGGRAPH '94 Proceedings), pgs. 295-302. The modified subdivision surface technique developed by Hoppe, et al, provides for an efficient method for modeling objects containing both curved surfaces and sharp features. The resulting sharp features are, however, infinitely sharp, i.e., the tangent plane is discontinuous across the sharp feature.

Even the method of Hoppe, et al. does not, therefore, solve the problem of modeling real objects with finite radius edges, creases and corners. To model such objects with existing techniques, either subdivision surfaces, NURBS, or polygons, requires vastly complicating the model by including many closely spaced control points or polygons in the region of the finite radius contour. As soon as one moves

away from infinite sharpness, which can be modeled easily and efficiently with subdivision surfaces following Hoppe, et al. most, if not all of the advantages of the method are lost, and one must create a vastly more complicated model to enjoy the incremental enhancement in realism. Accordingly, there is a need for a way to efficiently model objects with semi-sharp features and, more generally, there is a need for a way to sculpt the limit surface defined by subdivision without complicating the initial mesh.

SUMMARY OF THE INVENTION

The present invention involves a method for modeling objects with surfaces created by sequentially combining different subdivision rules. By subdividing a mesh a finite number of times with one or more sets of "special rules" before taking the infinite subdivision limit with "standard rules" one can produce different limit surfaces from the same initial mesh.

One important application of the invention is to the modeling of objects with smooth and semi-sharp features. The present invention allows one to model objects with edges and creases of continuously variable sharpness without adding vertices or otherwise changing the underlying control point mesh. The result is achieved in the exemplary embodiment by explicitly subdividing the initial mesh using the Hoppe, et al. rules or a variation which like the Hoppe, et al. rules do not require tangent plane continuity in the region of a sharp feature. After a finite number of iterations, one switches to the traditional continuous tangent plane rules for successive iterations. One may then push the final mesh points to their smooth surface infinite subdivision limits. The number of iterations performed with the "sharp" (i.e., discontinuous tangent plane) rules determines the sharpness of the feature on the limit surface. Though the number of explicit subdivisions must be an integer, "fractional smoothness" can be achieved by interpolating the position of points between the locations determined using N and N+1 iterations with the sharp rules.

In another exemplary embodiment, the invention is used to improve the shape of Catmull-Clark limit surfaces derived from initial meshes that include triangular faces.

BRIEF DESCRIPTION OF THE DRAWINGS

The file of this patent contains at least one drawing executed in color. Copies of this patent with color drawings will be provided by the Patent and Trademark Office upon request and payment of the necessary fee.

FIG. 1 shows generally the elements of a computer system suitable for carrying out the present invention.

FIG. 2 shows the main steps in generating a computer animation of a character using the techniques of the present invention.

FIG. 3 shows the control point mesh of Geri's head.

FIG. 4 shows some points on the skin mesh which contribute to the energy function.

FIG. 5 shows Geri's head with a scalar field for k_r in red.

FIG. 6 shows a portion of Geri's hand with articulation weights set to the default value before smoothing.

FIG. 7 shows Geri's hand with articulation weights as scalar field values derived by smoothing.

FIG. 8 shows the result of texture mapping on a subdivision surface using the method of the present invention.

FIG. 9 shows a neighborhood of a point in the control mesh prior to subdivision.

3

FIG. 10 shows a region of the control mesh with a sharp crease and its subdivision.

FIG. 11 shows the control mesh of Geri's hand with sharpness 1 features highlighted.

FIG. 12 shows the resulting semi-sharp features in a rendered image.

FIG. 13 shows a triangular face in the initial mesh and its first subdivision.

DETAILED DESCRIPTION OF AN EXEMPLARY EMBODIMENT

FIG. 1 shows a computer system suitable for carrying out the invention. A main bus 1 is connected to one or more CPU's 2 and a main memory 3. Also connected to the bus are a keyboard 4 and large disk memory 5. The frame buffer 6 receives output information from the main bus and sends it through another bus 7 to either a CRT or another peripheral which writes the image directly onto film. To illustrate the present invention we will describe its use in the animation of a character, Geri. The main steps in that process are summarized in FIG. 2.

The first step 21 involves the production of a two dimensional control mesh corresponding to a character to be modeled and animated. In the present case, the mesh, shown in FIG. 3, was derived from data scanned in from a physical model of Geri's head. Alternatively, the mesh could be created internally through a CAD program without a physical model. Depending on the type of geometrical primitives to be used, e.g. polygons, NURBS or sub-division surfaces, the set of the control points should be selected so that the chosen primitive representation provides an accurate fit to the original model or design and captures all poses of the character during the animation.

In an exemplary embodiment, Geri's head, depicted in FIG. 3, the control mesh contains approximately 4100 control points grouped to form approximately 4300 polygon faces. The points were entered manually using a touch probe on a physical model. Much care was taken in selecting the control points. Regions with fine scale details require more control points, i.e., smaller polygons. In addition, regions with larger polygons—greater spaced control points—should not directly abut regions of small polygons, instead, to prevent artifacts in the rendered image the number and position of control points should be chosen so that transitions between regions of high and low detail (i.e., little and big polygons) are smooth. In addition, one should select the control points so that creases, or other semi-sharp features along polygon edges (the treatment of these features will be discussed in detail below). Control points are stored as a list which includes an identifier and the three dimensional coordinates for each point. Points are grouped as polygons and stored in another list with a polygon identifier and the identifiers of the included points. Sharp features are also stored as ordered lists of vertices and sharpness values.

Once the set of control points, polygons and creases defining the kinematic head are entered and stored in the computer, the articulation engineer must determine how each point is to move for each gesture or character movement. This step 22 is done by coding animation controls, which effectuate transformations of the model corresponding to different movements, e.g., jaw down, or left eyebrow up. The transformations may be either linear displacements or, as in the "jaw down" control, rotation about a specified axis. The magnitude of the control, i.e., the amount of displacement or angle of rotation is specified by a scalar parameter, s , supplied by the animator. The corresponding

4

transformation of the model can be written as a function $T(s)$. The possible movements of Geri's face are specified using approximately 252 such controls. The articulation engineer can specify the relative motion of different control points under a given animation control by assigning weights to the control points. In the case of Geri's head, each of the 252 animation controls affects the motion of approximately 150 control points to which non-zero weights are assigned. The effect of the weight is to specify the "strength" of the transformation at the given point, i.e., the transformation T with strength s at a point with weight w is given by $T(w*s)$. The weights for a given control can either be assigned individually, control point by control point, or as a smooth scalar field covering the portion of the mesh whose location is altered by the transformation. The scalar field approach, described in detail in below, offers a great improvement in efficiency over the point-by-point approach which, for 252 controls times an average of 150 weights per control, would require individually specifying almost 40,000 weights to specify the motion of Geri's head alone.

The next step 23 in FIG. 2 is the creation of a second mesh of points, the skin mesh, which will typically be in one-to-one correspondence with the control points of the kinematic head. This need not be the case, however. In some embodiments, a skin mesh is used with a greater number of control points than are contained in the kinematic head and a projection of the skin points to the kinematic head is defined so that each skin point is "tied" to a unique point on the kinematic head (which need not be a control point). Other embodiments may have a skin mesh that is sparser than the underlying kinematic head. In that case, the same projection strategy can be used to tie skin control points to points on the kinematic head.

In the exemplary embodiment of Geri's head, the positions of the skin points were determined by copying the kinematic head control points while Geri's face was in the "neutral pose", which was taken to be the expression on the model head when it was scanned in with the touch probe. The "neutral pose" defines the equilibrium positions of the skin points, i.e., the position of Geri's features for which his skin mesh control points will exactly match the positions of the control points of the kinematic head.

In step 24, the articulation engineer specifies the properties of Geri's skin and the degree to which it is constrained to follow the underlying kinematic head. This is done by specifying the local parameters of an energy function, the extrema of which determine the position of the quasi-static surface, which in the present example is the skin on Geri's head. Though the details of the energy function used to simulate the skin on Geri's head is illustrative, variations are possible and will be readily apparent to those of ordinary skill in the art. The present invention is thus in no way limited to the details of the described implementation. That said, the energy function used to model Geri's head takes the form:

$$E = \sum_{\text{edge pairs}} E_{s1}(P_i, P_j) + \sum_{\text{non-edge pairs}} E_{s2}(P_i, P_j) + \sum_{\text{triplets}} E_p(P_i, P_j, P_k) + \sum_{\text{faces}} E_d(P_i, P_j, P_k, P_l) + \sum_{\text{points}} E_h(P_i)$$

The first term accounts for stretching of the skin surface and is given by: $E_{s1}(P_1, P_2) = k_{s1}(|P_1 - P_2| - R)^2$ where P_1 and P_2 , as shown in FIG. 4, are the locations (in R^3) of two nearest neighbor points connected by an edge of the mesh and R is the distance between the points in the neutral pose. k_{s1} is a

5

spring constant which can either be specified globally or locally for each edge as a combination of scalar field values for the two points, e.g., $K_{s1}(P_1, P_2)=S_1(P_1)+S_1(P_2)$ where $S_1(P_1)$ is a scalar field defined on the mesh by one of the methods described below. The second term includes contributions from nearest neighbor points which are not connected by an edge, e.g., points across a diagonal in a quadrilateral. $E_{s2}(P_1, P_3)$ has the same form as the first term but with a potentially different spring constant K_{s2} which again may be constant through out the mesh or defined locally by a second scalar field, $K_{s2}(P_1, P_3)=S_2(P_1)+S_2(P_3)$. The three point function $E_p(P_1, P_2, P_3)=K_p(|(P_3-P_2)/D_1-(P_2-P_1)/D_2|-R_p)^2$ is included to penalized bending and includes a contribution from each connected triplet of points. D_1 is the distance in R^3 between P_3 and P_2 in the neutral pose similarly D_2 is the distance between P_2 and P_1 in the neutral pose. R_p is the value of $|(P_3-P_2)/D_1-(P_2-P_1)/D_2|$ when all three points are in their neutral pose positions (note that this is not generally zero because (P_3-P_2) and (P_2-P_1) are vectors in R^3). The four point function, $E_d(P_1, P_2, P_3, P_4)=K_d E_{s2}(P_1, P_3)E_{s2}(P_2, P_4)$ includes a contribution from each quadrilateral face and is included to penalize skewing. The coefficient K_d may either be a constant throughout the mesh or a combination of scalar field values at the four vertices.

The last term in the energy function penalizes the skin points for straying from their corresponding kinematic mesh points: $E_h(P_s)=K_h|P_s-P_k|^2$ where P_s is a skin mesh point and P_k is its corresponding point in the kinematic mesh. The spring constant K_h is generally given by a scalar field associated with either the dynamic skin mesh or underlying kinematic mesh.

Defining Scalar Fields

Scalar fields were used at several points in the above described process in order to define smoothly varying parameters on either the kinematic mesh or skin mesh. These include the articulation weights which specify the relative movement of kinematic mesh control points under the different animation control transformations, as well as the various spring constants and other locally variable parameters of the energy function. When modeling with subdivision surfaces, the control point mesh is a polygonal mesh of arbitrary topology, on which one cannot define global surface coordinates and on which there is no "natural" or "intrinsic" smooth local parameterization. The absence of a local parameterization has slowed the adoption of subdivision surfaces as a means for modeling objects in computer animation, in part, because it was believed that a surface parametrization was necessary to define scalar fields and perform parametric shading, e.g., texture or surface mapping.

One aspect of the current invention is a solution to this problem and a method for consistently defining scalar fields on subdivision surfaces, including scalar fields which can be used as "pseudo-coordinates" to perform parametric shading. Three exemplary methods for defining smoothly varying scalar fields on arbitrary polygonal meshes which can be consistently mapped through the recursive subdivision process are described below.

Painting

The first method for defining scalar fields is by painting them directly onto the surface mesh. In this technique, an image of a portion of the surface on which the field is to be defined is painted using a standard two-dimensional computer painting program, e.g., Amazon, the intensity of the color applied to the image is chosen to represent the desired magnitude of the scalar field on the corresponding portion of the painted surface, e.g. if one wants the skin of Geri's fore-

6

head to more closely follow the movement of his kinematic head than the flesh in his jowls, one would paint his forehead correspondingly darker when "applying" the field giving rise to the parameter k_h in the above described energy function.

The first step in the painting method is to perform a single subdivision of the control point mesh in the region on which one intends to define the scalar field in order to obtain a mesh with only quadrilateral faces, as will always be the case after the first subdivision with Catmull-Clark rules (discussed in detail in the Subdivision section below). The faces in the once subdivided mesh are then numbered and separately coordinatized with two dimensional coordinates u and v assigned to each vertex (thus the need for quadrilateral faces). The surface is then further subdivided one or more additional times so that the resulting mesh sufficiently approximates the smooth surface limit. The u, v , coordinates for each patch (face in the once subdivided mesh) are carried through these additional subdivisions and coordinatize new vertices within the faces of the once subdivided mesh. The image is then rendered and painted with a two dimensional painting program such that the distribution and intensity of the applied color represents the desired local magnitude of the particular scalar field being defined. The painted image is then scanned and patch numbers, u, v , coordinates, and color intensity are stored for each pixel. Each patch is then further subdivided until a dense set of points is obtained within each patch including points with u, v coordinates close to those stored for each pixel in the painted image. The scanned pixel color intensities are then assigned as target scalar field values to the corresponding points in this further subdivided mesh.

Going back to the initial undivided mesh, one then assigns to its vertices initial guesses for the scalar field values which one hopes after several subdivisions will reproduce the target values. The mesh is then subdivided to the level of refinement at which the target values were assigned with scalar field values calculated from the initial guesses using the same subdivision rules used to calculate vertex locations in the refined mesh. The values of the scalar field at the target points resulting from subdividing the mesh with the initial guesses is then compared with the target values at the corresponding points. Differences from the target values are computed and averaged back, reversing the subdivision calculations, to find corrections to the initial guesses for scalar field values at the vertices in the unsubdivided mesh. This comparison and correction process is iterated until convergence. The result is a smooth field that closely approximates the painted intensities defined for any level of subdivision including the smooth surface limit.

Smoothing

The second more direct, if less picturesque, method for defining scalar fields is through smoothing. One begins by specifying values of the desired field explicitly at some boundary or known points in a region of the mesh and solving for the rest through an iterative relaxation approach constraining the scalar field value of the vertices to be equal to the average of their nearest neighbors. FIG. 5 shows Geri's face with the k_h ("glue" field) shown in red. Smoothing was used in applying the k_h field to his chin region. The use of this method to assign smoothly varying articulation weights is illustrated in FIGS. 6 and 7. To assign articulation weights to control points in the transition region between Geri's thumb which will move with full strength, $w=1$ under the control, and his palm which will not move at all, i.e., have weight 0 under the control, one begins by enforcing these conditions and, as shown in FIG. 4, by giving the control points in the intermediate region default values of 1. One

then performs the iterative relaxation smoothing calculation until one obtains the result shown in FIG. 5., a smooth interpolation of intermediate scalar field values over the control points in the transition region.

Energy Method

Scalar fields can also be used as pseudo coordinates to enable parameteric shading, e.g., texture and surface mapping. One reason that subdivision surfaces have not been more widely adopted for modeling in computer graphics is that the absence of a surface parameterization was thought to prevent the use of texture maps. One can, however, utilizing one aspect of the present invention, define s and t scalar fields ("pseudo-coordinates") on regions of the subdivision surface which can serve as local coordinates for texture mapping. One cannot, of course, trick topology, so these pseudo coordinate fields can only be consistently defined in topologically flat regions of the surface. One can then patch these regions together either discontinuously (e.g., if one wanted two different pieces of cloth to abut along a seam) or continuously (by requiring fields in overlapping regions to have common values). Pseudo-coordinates need only be defined, and consistency requirements need only be enforced after the model has been animated and only in regions in which the texture mapping is to be applied. These static pseudo-coordinate patching constraints are thus far easier to deal with and satisfy than the ubiquitous kinematic constraints required to model complex objects with NURB patches.

Though s and t fields can be defined using either the painting or smoothing method described above, an elaboration of the smoothing method, the energy method, is useful for defining scalar fields to be used as pseudo-coordinates for texture mapping. To avoid unacceptable distortions in the surface texture, the mapping between the surface in R^3 and the s and t pseudo-coordinate parameterization of the texture sample in R^2 should be at least roughly isometric (i.e. preserve lengths and angles). If one pictures the mapping of the two dimensional texture onto the surface as fitting a rubber sheet over the surface, one wants to minimize the amount of stretching and puckering. If the mapping is onto a portion of the surface with curvature, a pucker free mapping is not possible. A best fit, so to speak, can be achieved, however, by utilizing the first two terms in the energy function described above restricted to two dimensions. Though this technique for achieving a "best fit" approximate isometry is useful for texture mapping onto other curved surfaces, including those defined by NURBS, as will be readily apparent to one of ordinary skill in the art, its implementation will be described in detail for the case of subdivision surfaces.

The aim is to insure that as closely as the geometry allows distances between points measured along the surface embedded in R^3 equal distances measured between the same points in the flat two dimensional s and t pseudo-coordinates of the texture patch for all points on the surface to which the texture mapping is to be applied. To achieve a good approximation to this best compromise solution, we begin by subdividing the initial mesh several times in the region to be texture mapped. This provides a fine enough mesh so that the distances between nearest neighbor vertices measured in R^3 sufficiently approximate the distance between the same points measured along the surface. One then generally orients the texture on the surface by assigning s and t pseudo coordinates to several control points. One then completes the mapping, finding pseudo-coordinate s and t values for the remaining mesh vertices, by minimizing a two dimensional energy function over the region of the mesh on which the

texture is to be applied. An exemplary energy function contains the two point functions from the energy function defined above, i.e.,

$$E = \sum_{\substack{\text{edge} \\ \text{pairs}}} E_1(P_i, P_j) + \sum_{\substack{\text{non-edge} \\ \text{pairs}}} E_2(P_i, P_j)$$

with as before $E_1(P_1, P_2) = k_1(|P_1 - P_2| - R)^2$ but now R is the distance between the points as measured along the surface (as approximated by adding distances in three space along the subdivided mesh) and $|P_1 - P_2|$ is the two dimensional Euclidean distance between the points' s and t pseudo-coordinates, i.e., $\sqrt{(s_1 - s_2)^2 + (t_1 - t_2)^2}$. This energy function can be minimized using Newton's method or other standard numerical technique as described below for minimizing the full energy function to determine the position of skin points.

Off-Line Steps

At this point in the process all of the manual steps in the animation are finished. The remaining steps can all be performed "off-line" as a precursor to the actual rendering of the scene. Because these steps do not require additional input by the animator and take a small fraction of the computation time required for rendering, they add little to the time required for the overall animation project.

Minimizing the Energy Function to Determine the Position of Skin Points

The positions of the control points for the surface mesh are determined by minimizing the energy function. This can be done iteratively using Newton's method or other standard numerical technique. For each frame of animation, the location of the skin control points can be taken initially to correspond with the positions of the control points of the kinematic mesh. A quadratic approximation to the energy function is then computed and minimized yielding approximate positions for the control points for the surface mesh. These approximate positions are used in the next quadratic approximation which is solved yielding more refined approximate positions. In practice, a few iterations generally suffice.

To drive the system to a definite solution in the situation in which the energy function has a null space, an additional term is added to the energy function for each point in the dynamic mesh which, for the n th iteration, takes the form $\alpha N |P_i^n - P_i^{n-1}|^2$. Where N is the number of successive quadratic approximation iterations performed per frame and P_j^n is the position of the j th control point after n iterations. Though the discussion of the exemplary embodiment to this point has dealt primarily with the quasi-static determination of the surface control point locations, this degeneracy breaking term can be slightly modified to allow for the incorporation of dynamic effects as well, e.g., momentum of the surface mesh. To do so one can replace the above described term with one of the form $E_m = \alpha N |P_i^n - 2P_i^{n-1} + P_i^{n-2}|^2$. One can then treat the iteration index as indicating time steps as well and update the underlying kinematic control point positions in steps between frames. The incorporation of momentum in this manner may be useful in some cases, e.g., to automatically incorporate jiggling of fleshy characters.

Subdivision

Once the positions of the skin mesh vertices are determined by iteratively minimizing the energy function, the model can be refined prior to rendering in order to produce a smoother image. One method for refining the mesh is through recursive subdivision following the method of Catmull and Clark. See E. Catmull and J. Clark. Recursively generated B-Spline surfaces on arbitrary topological

meshes. Computer Aided Design, 10(6):350–355, 1978. One could apply other subdivision algorithms, e.g., Doo and Sabin, see D. Doo and M. Sabin. Behavior of recursive division surfaces near extraordinary points. Computer Aided Design, 10(6): 356–360, 1978, or Loop if one chose the initial mesh to be triangular rather than quadrilateral, see Charles T. Loop. Smooth subdivision surfaces based on triangles. M. S. Thesis, Department of Mathematics, University of Utah, August 1987. In the current example Catmull-Clark subdivision was used in part because a quadrilateral mesh better fits the symmetries of the objects being modeled. In the limit of infinite recursion. Catmull-Clark subdivision leads to smooth surfaces which retain the topology of the initial mesh and which are locally equivalent to B-Splines except in the neighborhoods of a finite number of exceptional points at which the initial mesh had a vertex or face with other than 4 edges.

The details of constructing smooth surfaces (and approximations to smooth surfaces) through subdivision is now well known in the art and will only be discussed briefly for completeness and as background to the discussion of hybrid subdivision below. FIG. 9 shows a region about a vertex in a quadrilateral mesh. This may be either the initial skin mesh or the mesh resulting from one or more subdivisions. The vertex has n edges. For a “normal point,” $n=4$. If n is not equal to 4, the point is one of a finite number of exceptional points which will exist in any mesh that is not topologically flat. The number of such points will not increase with subdivision. FIG. 10 shows the same region overlaid with the mesh resulting from a single subdivision. The positions of the resulting vertices which can be characterized as either vertex, edge, or face vertices, are linear combinations of the neighboring vertices in the unsubdivided mesh:

$$q_i = \frac{1}{4}(Q_i + R_{i-1} + R_i + S)$$

$$r_i = \frac{1}{4}(q_i + q_{i+1} + R_i + S)$$

$$s = \sum_{i=1}^n (q_i + R_i) / n^2 + \frac{(n-2)}{nS}$$

Where j runs from 1 to n , the number of edges leaving the vertex S . Capital letters indicate points in the original mesh and small letters represent points in the next subdivision. The subdivision process can be written as a linear transformation taking the vector $V=(S, R_1, \dots, R_n, Q_1, \dots, Q_n)^T$ to the vector $v=(s, r_1, \dots, r_n, q_1, \dots, q_n)^T$ defined by the $2n+1$ by $2n+1$ square matrix M_n : $v=M_n V$. For Catmull-Clark subdivision about an ordinary point, i.e., when $n=4$, using the subdivision formulas given above M_n takes the form:

$$M_4 = 1/16 \begin{pmatrix} 9 & 3 & 3 & 3 & 3 & 1 & 1 & 1 & 1 \\ 6 & 6 & 1 & 0 & 1 & 1 & 0 & 0 & 1 \\ 6 & 1 & 6 & 1 & 0 & 1 & 1 & 0 & 0 \\ 6 & 0 & 1 & 6 & 1 & 0 & 1 & 1 & 0 \\ 6 & 1 & 0 & 1 & 6 & 0 & 0 & 1 & 1 \\ 4 & 4 & 4 & 0 & 0 & 4 & 0 & 0 & 0 \\ 4 & 0 & 4 & 4 & 0 & 0 & 4 & 0 & 0 \\ 4 & 0 & 0 & 4 & 4 & 0 & 0 & 4 & 0 \\ 4 & 4 & 0 & 0 & 4 & 0 & 0 & 0 & 4 \end{pmatrix}$$

In practice, the subdivision procedure is applied a finite number of times, depending on the level of detail required of the object which may be specified explicitly or determined

automatically as a function of the screen area of the object in a given scene. Typically if one starts with an initial mesh with detail on the order of the control mesh for Geri's head, 4 or 5 subdivisions will suffice to produce quadrilateral faces corresponding to a screen area in the rendered image of a small fraction of a pixel. Iterating the above formulas gives the positions and scalar field values for the vertices in the finer subdivided mesh as a function of the positions and scalar field values of the control mesh.

After a sufficient number of iterations to produce enough vertices and small enough faces for the desired resolution, the vertex points and their scalar field values can be pushed to the infinite iteration smooth surface limit. In the case of Catmull-Clark surfaces, the smooth surface limit is a cubic spline everywhere but in the neighborhoods of the finite number of extraordinary points in the first subdivision of the original mesh. These limit values are easily determined by analyzing the eigenspectrum and eigenvectors of the subdivision matrix, M_n . See M. Halstead, M. Kass, and T. DeRose. Efficient, fair interpolation using Catmull-Clark surfaces, Computer Graphics (SIGGRAPH 1993 Proceedings), volume 27, pages 35–44, August 1993. Specifically, applying the matrix M_n to a vector an infinite number of times projects out the portion of the initial vector along the direction of the dominant right eigenvector of the matrix M_n . If we take $m=2n+1$, the size of the square matrix M_n , then we can write the eigenvalues of M_n as $e_1 \cong e_2 \cong \dots \cong e_m$ with corresponding right eigenvectors E_1, \dots, E_m . We can then uniquely decompose V as

$$V=c_1 E_1+c_2 E_2+\dots+c_m E_m$$

Where the c_j are three dimensional coordinates and/or values of various scalar fields on the surface but are scalars in the vector space in which M_n acts. Applying M_n we get $M_n V=e_1 c_1 E_1+e_2 c_2 E_2+\dots+e_m c_m E_m$. For $(M_n)^\infty V$ to have a nontrivial limit the largest eigenvalue of M_n must equal 1. So that $(M_n)^\infty V=c_1 E_1$. Finally, Affine invariance requires that the rows of M_n sum to 1 which means that $E_1=(1, \dots, 1)$. Which gives $s^\infty=c_1$.

If one chooses a basis for the left eigenvectors of M_n , L_1, \dots, L_m so that they form an orthonormal set with their right counterparts, i.e., $L_j \cdot E_k=\delta_{jk}$, this projection is given by the dot product $L_1 \cdot V$ where L_1 is the left eigenvector of M_n with eigenvalue 1 and V is the column vector defined above of points in the neighborhood of S . For Catmull-Clark subdivision, the value of this dot product and thus the position of the point s after infinite subdivision is given by

$$s^\infty = \frac{1}{n(n+5)} \left(n^2 s + 4 \sum_{i=1}^n r_i + \sum_{i=1}^n q_i \right)$$

This formula gives not only the smooth surface limit value of the position of the vertex points in R^3 but can also be used to calculate the smooth surface limit of any scalar fields at those points as a function of their values at points in the neighborhood of S .

Similarly, with a bit more math, see Halstead, et al. cited above, it can be shown that the eigenvectors for the second and third largest eigenvalues of the local subdivision matrix M_n span the tangent space of the limit surface at the point s^∞ . One can again project these out of the vector V using the orthonormality property of the left and right eigenvectors giving $c_2=L_2 \cdot V$ and $c_3=L_3 \cdot V$. Because c_2 and c_3 span the tangent space at the point s^∞ , their cross product gives a vector normal to the limit surface at that point, i.e., $N^\infty=c_2 \times$

11

C_3 at the point s^∞ . These tangent vectors have been calculated for Catmull-Clark subdivision and are given by:

$$c_2 = \sum_{i=1}^n A_n \cos(2\pi i/n) r_i + (\cos(2\pi i/n) + \cos(2\pi(i+1)/n)) q_i$$

Where

$$A_n = 1 + \cos(2\pi/n) + \cos(\pi/n) \sqrt{2(9 + \cos(2\pi/n))}$$

and c_3 is obtained by replacing r_1 with r_{i+1} and q_i with q_{i+1} .

After constructing N^∞ , the smooth surface limit normal, at each of the vertices of the refined mesh. One can then interpolate these normals across the subpixel faces of the refined mesh to render the character using Phong shading.

Hybrid Subdivision Schemes

One aspect of the present invention is a method for creating surfaces by sequentially combining different subdivision rules. By subdividing a mesh a finite number of times with one or more sets of "special rules" before taking the infinite subdivision limit with the "standard rules", one can produce different limit surfaces from the same initial mesh. Combining different subdivision rules thus provides an additional degree of freedom which can be a more efficient means for obtaining the desired limit surface than adding points to the initial mesh. Below we describe in detail two particular exemplary uses of this aspect of the invention in modeling Geri. Many others will be readily apparent to those of ordinary skill in the art.

Semi-Sharp Edges and Creases

Human skin is not a completely smooth surface. Faces and hands, for example, contain somewhat sharp features, both creases and edges. To model these features using the general smooth-surface-limit subdivision techniques outlined above, or more conventional B-spline patch methods, would require a very complicated initial control mesh in which the vertex spacing in regions of sharp features would have to be very small, leading to lots of points and quadrilaterals. One method for modeling sharp features with subdivision surfaces without adding substantially to the complexity of the initial control mesh is to alter the subdivision rules for points lying on corners or sharp edges or creases. As described above, these features can be incorporated and tagged in the initial control mesh.

The sharpness of these features can be maintained throughout the otherwise smoothing subdivision process by decoupling the subdivision process along sharp edges so that points on either side of the sharp feature do not contribute to the position of points on the edge in subsequent subdivisions. Locally modifying the subdivision algorithm in this way results in a limit surface with sharp edges or creases across which the tangent plane is discontinuous. Details of this method for modeling various sharp features using Loop subdivision on a triangular mesh can be found in Hoppe, et al. Piecewise smooth surface reconstruction. Computer Graphics (SIGGRAPH '94 Proceedings) (1994) 295-302.

The problem with using the Hoppe, et al. approach for the realistic animation of characters is that skin surfaces do not have infinitely sharp edges. All real objects, including humans, have some finite radius of curvature along their otherwise sharp features. This fact may be ignored when rendering machined metal objects but is very apparent when modeling and rendering human faces. The exemplary embodiment includes a modification of the above described

12

subdivision algorithm to allow the modeling and rendering of edges and creases of arbitrary and continuously variable sharpness.

FIG. 11 shows a portion of the initial control mesh of Geri's hand with sharp features highlighted. As described above, care was taken in the initial choice of mesh vertices so that these sharp features lay along edges of the initial mesh. Their position in the mesh was stored along with a sharpness value between 0 and 5 (assuming 5 explicit subdivisions was the maximum performed before pushing the vertices to their limits). Because the skin mesh has the same topology as the control mesh, the corresponding edge in the skin mesh is uniquely identified. To model an edge or crease with sharpness N where N is an integer, one applies the sharp edge subdivision technique described in Hoppe et al. to determine the locations of points along the designated edge or crease for the first N subdivisions. Thus to determine new edge and vertex locations along the crease or edge instead of applying the standard Catmull-Clark formulas described above, one uses for example the following sharp edge formulas:

$$r_i = \frac{1}{2}R_i + \frac{1}{2}S$$

$$s = \frac{1}{8}R_j + \frac{1}{8}R_k + \frac{3}{4}S$$

where R_j and R_k are the points on either side of S along the sharp edge or crease, as shown in FIG. 10. If S is a vertex at which a crease or edge ceases to be sharp its position after subdivision is calculated using the normal Catmull-Clark formulas.

After N subdivisions one applies the normal smooth algorithm for subsequent explicit subdivisions and then pushes the points to their smooth surface limits. Thus for sharpness 2 features, one applies the sharp formulas for the first two subdivisions and then uses the smooth formulas for subsequent subdivision and for taking the smooth surface limit. One can get "fractional sharpness" e.g., 1.5, by linearly interpolating edge point locations between the sharpness 1 and 2 results, i.e., calculate the position of control points after performing one sharp and one smooth subdivision and calculate the position of control points after subdividing twice with the sharp subdivision rules and take the average of the two locations before subdividing farther with the smooth rules or pushing the points to their smooth surface limits.

One can also determine the positions and tangents on the limit surface of points in the initial mesh on a semisharp feature without explicitly iterating the semisharp rules, by analyzing the eigenstructure of the combined transformation matrix in a manner similar to that described above for the case of smooth subdivision. The limit surface position for the neighborhood of a semisharp feature of sharpness k is given by

$v^\infty = (M_{smooth})^\infty (M_{sharp})^k V$ where we have suppressed the n index indicating the number of edges and added a subscript designating smooth and sharp transformations. As above for the smooth case, we can replace the application of M_{smooth} an infinite number of times with dotting by L_1 its dominant left eigenvector, giving $v^\infty = L_1 \cdot (M_{sharp})^k V$. We can then replace L_1 by its decomposition in terms of left eigenvectors of M_{sharp} . $L_1 = t_1 l_1 + t_2 l_2 + \dots + t_m l_m$ where l_i are left eigenvectors of M_{sharp} and t_j are expansion coefficients, scalars under M_{sharp} . Applying M_{sharp} k times from the right to this expansion, we get: $v^\infty = (t_1 \lambda_1^k l_1 + \dots + t_m \lambda_m^k l_m)$ where the λ_j are the eigenvalues of M_{sharp} .

One may also create a feature with varying sharpness along its length. Assuming again that the initial mesh is created so that the sharp feature lies along one or more connected edges, one can specify sharpness values at the vertices of the feature either by hand or by one of the scalar field techniques described above, limited to one dimension. One can calculate the limit values of the sharpness field treating the sharp feature as a subdivision curve and taking its limit value using the dominant left eigenvector as described above for two dimensional surface subdivision. For uniform cubic B-Spline subdivision along a curve, that vector is given by $u_1 = \frac{1}{6}[1,4,1]$. See, e.g. E. Stollnitz, T. DeRose and D. Salesin. Wavelets for Computer Graphics, 1996, 61-72. The limit value of the field on a point along the semi-sharp feature is thus given by $\frac{2}{3}$ of its value plus one $\frac{1}{6}$ of the value of each of its nearest neighbors.

The location of each vertex point on the semisharp feature is then calculated using the limit value of its sharpness field, i.e., one applies the sharp rules in the neighborhood of that point the number of times specified by the point's sharpness value (including interpolation, as described above for non-integer sharpness values).

This continuous smoothing of sharp edges can be used in conjunction with other subdivision schemes as well including those proposed by Loop and Doo and Sabin, cited above. In particular, all of the sharp edge techniques and results of Hoppe, et al. can be extended to allow for the efficient modeling of semi-sharp features by combining smooth and sharp subdivision rules in the manner described above for Catmull-Clark subdivision.

Improving The Surface In the Neighborhood of Triangular Faces

A second application of hybrid subdivision used in the exemplary embodiment involves a modification to the standard Catmull-Clark rules used to determine the location of face points in the first subdivision of a triangular face. As described above, if one begins with an arbitrary polygon mesh which includes non-quadrilateral faces, after one subdivision with Catmull-Clark rules, all faces in the refined mesh will be quadrilateral (though some vertices will have more than four edges). If one has an initial mesh which is convex with some triangular faces, e.g., the initial control point mesh of Geri's head, the smooth surface resulting from standard Catmull-Clark subdivision will be somewhat "lumpy" in regions in which there were triangular faces in the original mesh. The shape of the limit surface can be improved if when calculating the location of the face point for a triangular face in the first subdivision (the only time there will be triangular faces), one takes its location to be the average of the locations of its surrounding edge points after subdivision rather than the average of the its surrounding vertices in the undivided mesh, the standard Catmull-Clark rule. This is illustrated in FIG. 13. The solid lines and points P_i are points in the initial mesh. The dashed lines show the once subdivided mesh with points e_i and f . Under normal Catmull-Clark rules the location of f is given by: $f = \frac{1}{3}(P_1 + P_2 + P_3)$. Instead, we take $f = \frac{1}{3}(e_1 + e_2 + e_3)$. Because the e_i locations of neighboring faces as well as the P_i , f will be drawn closer to the center of a convex mesh and the limit surface will have a smoother contour.

The specific arrangements and methods described herein are merely illustrative of the principles of the present invention. Numerous modifications in form and detail may be made by those of ordinary skill in the art without departing from the scope of the present invention. Although this invention has been shown in relation to particular embodiments, it should not be considered so limited. Rather, the present invention is limited only by the scope of the appended claims.

What is claimed is:

1. A computer-implemented method for generating a [surface] feature of a limit surface in a graphical object represented at least in part as a polygonal mesh, said computer-implemented method comprising [the steps of]:

a) subdividing all or part of a polygon mesh representation of at least a portion of said graphical object a first number of times using one or more shape parameters and a first set of rules to produce a first mesh representation in addition to the polygon mesh of said at least a portion of said graphical object, wherein at least one of the shape parameters has a non-integer value that defines the limit surface;

b) subdividing said first mesh representation [of said at least a portion of said graphical object] a second number of times using a second set of rules, different than said first set of rules, for generating a second mesh representation [of said at least a portion of said graphical object] in addition to the first mesh representation and the polygon mesh representation; and

c) outputting a representation of said graphical object having said surface feature;

wherein a sum of the first and second numbers is equal to a total number of iterations required to achieve the [surface] feature of the limit surface; and wherein the points on the limit surface are determined as the infinite subdivision limit of the second mesh using the second set of rules.

[2. The method of claim 1 wherein the points on a limit surface are determined by taking the infinite subdivision limit of said second mesh using said second set of rules.]

3. The method of claim [2] 1 comprising the further step of determining the smooth surface limit normals at the limit locations of the points in the final mesh in order to shade the rendered image.

4. In a computer graphics system, a method of creating subdivision surface features in graphical objects the method comprising [the steps of]:

sequentially applying distinct first and second sets of subdivision rules to a polygonal mesh representation of a feature of a limit surface of a graphical object; and displaying said graphical object having said feature;

wherein said first set of subdivision rules uses one or more shape parameters, wherein the second set of subdivision rules is applied to an intermediate mesh representation, in addition to the polygonal mesh representation, resulting from the application of said first set of subdivision rules to said polygonal mesh representation [of said feature of said graphical object], wherein at least one of the shape parameters has a non-integer value that define the limit surface, and wherein the points on the limit surface are determined as the infinite subdivision limit of the intermediate mesh using the second set of rules.

5. A computer readable medium storing code for controlling a processor to generate render data, the code comprising:

code that directs the processor to retrieve a polygonal mesh associated with a three-dimensional object;

code that directs the processor to subdivide the polygonal mesh to form a first subdivided polygonal mesh using one or more shape parameters and a first subdivision rule, wherein the first subdivided polygonal mesh comprises a first plurality of vertices, and wherein at least one of the shape parameters has a non-integer value that defines a limit surface;

15

code that directs the processor to subdivide the first subdivided polygonal mesh one or more times to form a second subdivided polygonal mesh using a second subdivision rule, wherein the second subdivision rule is different than the first subdivision rule, wherein the second subdivided polygonal mesh comprises a second plurality of vertices;

code that directs the processor to determine a first plurality of scalar values associated with vertices from the second plurality of vertices;

code that directs the processor to determine a second plurality of scalar values associated with vertices from the first plurality of vertices in response to the first plurality of scalar values; and

code that directs the processor to output data for rendering a portion of the three-dimensional object based on the second plurality of scalar values, and

wherein the points on the limit surface are determined as the infinite subdivision limit of the second subdivided polygonal mesh using the second subdivision rule.

6. The computer readable medium of claim 5 wherein scalar values from the second plurality of scalar values comprise parametric shading values.

7. The computer readable medium of claim 5 further comprising:

code that directs the processor to determine a third plurality of scalar values associated with the vertices from the second plurality of vertices in response to the first plurality of scalar values and the second plurality of scalar values; and

wherein the scalar values from the third plurality of scalar values are used for mapping purposes selected from the group consisting of: texture, surface.

8. The computer readable medium of claim 5 further comprising:

code that directs the processor to determine a third plurality of scalar values associated with the vertices from the second plurality of vertices in response to the first plurality of scalar values and the second plurality of scalar values; and

code that directs the processor to render a portion of the three-dimensional object in response to the third plurality of scalar values.

9. The computer readable medium of claim 5 wherein the scalar values from the first plurality of scalar values comprise parameters selected from the group consisting of: kinematic parameters, animation parameters.

10. The computer readable medium of claim 5 wherein code that directs the processor to determine the first plurality of scalar values comprises code that directs the processor to determine the first plurality of scalar values associated with the vertices from the second plurality of vertices in response to a projection of a two-dimensional image comprising intensity values.

11. The computer readable medium of claim 5 wherein code that directs the processor to determine the first plurality of scalar values comprises code that directs the processor to smooth a third plurality of scalar values associated with the vertices from the second plurality of vertices.

12. The computer readable medium of claim 11 wherein the third plurality of scalar values associated with the vertices from the second plurality of vertices are specified by a user.

13. The computer readable medium of claim 11 wherein the third plurality of scalar values comprise energy values.

14. The computer readable medium of claim 5 wherein the code that directs the processor to determine the second plurality of scalar values comprises:

16

code that directs the processor to receive a plurality of estimated scalar values associated with the first plurality of vertices;

code that directs the processor to determine a plurality of estimated scalar values associated with the second plurality of vertices;

code that directs the processor to determine a plurality of error values in response to the plurality of estimated scalar values and the plurality of estimated scalar values associated with the second plurality of vertices; and

code that directs the processor to determine the second plurality of scalar values associated with the first plurality of vertices in response to the plurality of estimated scalar values associated with the first plurality of vertices, and in response to the plurality of error values.

15. A computer system that comprises:

a memory configured to store a polygonal mesh associated with a three-dimensional object, wherein the memory is also configured to store a scalar field; and

a processor coupled to the memory, wherein the processor is configured to retrieve the polygonal mesh associated with a three-dimensional object from the memory, wherein the processor is also configured to subdivide the polygonal mesh to form a first subdivided polygonal mesh using one or more shape parameters and a first subdivision rule, wherein at least one of the shape parameters has a non-integer value that defines a limit surface, wherein the first subdivided polygonal mesh comprises a first plurality of vertices, wherein the processor is configured to subdivide the first subdivided polygonal mesh one or more times to form a second subdivided polygonal mesh using a second subdivision rule, wherein the first subdivision rule is different than the second subdivision rule, wherein the second subdivided polygonal mesh comprises a second plurality of vertices, wherein the processor is configured to determine a first plurality of scalar values associated with vertices from the second plurality of vertices in response to the scalar field,

wherein the processor is configured to determine a second plurality of scalar values associated with vertices from the first plurality of vertices in response to the first plurality of scalar values, and wherein the processor is configured output data for rendering a portion of the three dimensional object based on the second plurality of scalar values, and

wherein the points on the limit surface are determined as the infinite subdivision limit of the second subdivided polygonal mesh using the second subdivision rule.

16. The computer system of claim 15 wherein scalar values from the second plurality of scalar values comprise parametric shading values.

17. The computer system of claim 15

wherein the processor is configured to determine a third plurality of scalar values associated with the vertices from the second plurality of vertices in response to the first plurality of scalar values and the second plurality of scalar values; and

wherein the scalar values from the third plurality of scalar values are used for a mapping purpose selected from the group consisting of: texture, surface.

18. The computer system of claim 15

wherein the processor is also configured to determine a third plurality of scalar values associated with the ver-

tices from the second plurality of vertices in response to the first plurality of scalar values and the second plurality of scalar values, and wherein the processor is configured to render a portion of the three-dimensional object in response to the third plurality of scalar values.

19. The computer system of claim 15 wherein the scalar values from the first plurality of scalar values comprise parameters selected from the group consisting of: kinematic parameters, animation parameters.

20. The computer system of claim 15 wherein the scalar field comprises a two-dimensional image comprising intensity values.

21. The computer system of claim 15

wherein the scalar field specifies a third plurality of scalar values associated with at least some of the vertices from the second plurality of vertices; and

wherein the processor is configured to determine the first plurality of scalar values by smoothing the third plurality of scalar values associated with the vertices from the second plurality of vertices.

22. The computer system of claim 21 wherein the third plurality of scalar values associated with at least some of the vertices from the second plurality of vertices are specified by a user.

23. The computer system of claim 21 wherein the third plurality of scalar values comprise energy values.

24. The computer system of claim 15 wherein the processor is configured to determine the second plurality of scalar values by being configured to receive a plurality of estimated scalar values associated with the first plurality of vertices, being configured to determine a plurality of estimated scalar values associated with the second plurality of vertices, being configured to determine a plurality of error values in response to the plurality of estimated scalar values and the plurality of estimated scalar values associated with the second plurality of vertices, and being configured to determine the second plurality of scalar values associated with the first plurality of vertices in response to the plurality of estimated scalar values associated with the first plurality of vertices, and in response to the plurality of error values.

25. A method for a computer system that comprises:

retrieving a polygonal mesh associated with a three-dimensional object;

subdividing the polygonal mesh using one or more shape parameters and a first subdivision rule to form a first subdivided polygonal mesh including a first plurality of vertices, wherein at least one of the shape parameters has a non-integer value that defines a limit surface;

subdividing the first subdivided polygonal mesh one or more times using a second subdivision rule to form a second subdivided polygonal mesh comprising a second plurality of vertices, wherein the first subdivision rule and the second subdivision rule are different;

determining a first plurality of scalar values, wherein the first plurality of scalar values is associated with vertices from the second plurality of vertices;

determining a second plurality of scalar values in response to the first plurality of scalar values, wherein the second plurality of scalar values is associated with vertices from the first plurality of vertices; and

outputting data for rendering at least a portion of the three dimensional object based on the second plurality of scalar values and

wherein the points on the limit surface are determined as the infinite subdivision limit of the second subdivided polygonal mesh using the second subdivision rule.

26. The method of claim 25 wherein scalar values from the second plurality of scalar values comprise parametric shading values.

27. The method of claim 25 further comprising:

determining a third plurality of scalar values in response to the first plurality of scalar values and the second plurality of scalar values, wherein the third plurality of scalar values is associated with the vertices from the second plurality of vertices;

wherein the scalar values from the third plurality of scalar values are used for mapping purposes selected from the group consisting of: texture mapping, surface mapping.

28. The method of claim 25 further comprising:

determining a third plurality of scalar values in response to the first plurality of scalar values and the second plurality of scalar values, wherein the third plurality of scalar values is associated with the vertices from the second plurality of vertices; and

rendering a portion of the three-dimensional object in response to the third plurality of scalar values.

29. The method of claim 25 wherein the scalar values from the first plurality of scalar values comprise parameters selected from the group consisting of: kinematic parameters, animation parameters.

30. The method of claim 25 wherein determining the first plurality of scalar values comprises determining the first plurality of scalar values in response to a projection of a two-dimensional image comprising intensity values onto the second plurality of vertices.

31. The method of claim 25 wherein determining the first plurality of scalar values comprises smoothing a third plurality of scalar values, wherein the third plurality of scalar values is associated with at least some of the vertices from the second plurality of vertices.

32. The method of claim 31 wherein the third plurality of scalar values are specified by a user.

33. The method of claim 31 wherein the third plurality of scalar values comprise energy values.

34. The method of claim 25 wherein determining the second plurality of scalar values comprises:

receiving a plurality of estimated scalar values associated with the first plurality of vertices;

determining a plurality of estimated scalar values associated with the second plurality of vertices in response to the plurality of estimated scalar values associated with the first plurality of vertices;

determining a plurality of error values in response to the plurality of estimated scalar values and the plurality of estimated scalar values associated with the second plurality of vertices; and

determining the second plurality of scalar values associated with the first plurality of vertices in response to the plurality of estimated scalar values associated with the first plurality of vertices, and in response to the plurality of error values.

35. The method of claim 25, wherein the one or more shape parameters are assigned to one of a vertex, a plurality of vertices, a face, a plurality of faces, an edge, a plurality of edges, or a plurality of connected edges.

36. The method of claim 25, wherein one or both of the first plurality of scalar values and the second plurality of scalar values represent coordinates.

37. A computer-implemented method for generating a feature of a limit surface in a graphical object represented at least in part as a polygonal mesh, the computer-implemented method comprising:

19

- a) receiving one or more shape parameters associated with a polygon mesh representation of at least a portion of the graphical object, wherein at least one of the shape parameters has a non-integer value that defines the limit surface;
- b) subdividing all or part of the polygon mesh representation a first number of times using the one or more shape parameters and a first set of rules to produce a first mesh representation in addition to the polygon mesh of the at least a portion of said graphical object;
- c) subdividing the first mesh representation a second number of times using a second set of rules, different than the first set of rules, for generating a second mesh representation in addition to the first mesh representation and the polygon mesh representation; and
- d) outputting a representation of the graphical object having the surface feature;

20

wherein a sum of the first and second numbers is equal to a total number of iterations required to achieve the feature of the limit surface; and

wherein the points on the limit surface are determined as the infinite subdivision limit of the second mesh using the second set of rules.

38. The method of claim 37, wherein the one or more shape parameters are selected or input by a user.

39. The method of claim 1, wherein the one or more shape parameters are assigned to one of a vertex, a plurality of vertices, a face, a plurality of faces, an edge, a plurality of edges, or a plurality of connected edges.

40. The method of claim 1, wherein the non-integer value of the at least one shape parameter enables a sharpness of the feature of the limit surface to vary continuously.

* * * * *