

US00RE41628E

(19) **United States**
(12) **Reissued Patent**
Barbeau et al.

(10) **Patent Number:** **US RE41,628 E**
(45) **Date of Reissued Patent:** **Sep. 7, 2010**

- (54) **AUTOILLUMINATING LAMP SYSTEM**
- (75) Inventors: **Stefane E. Barbeau**, Roxbury, MA (US); **Duane B. Smith**, Boston, MA (US); **Donald E. Drumm**, Billerica, MA (US)
- (73) Assignee: **Helen of Troy Limited**, St. Michael (BB)
- (21) Appl. No.: **11/600,966**
- (22) Filed: **Nov. 16, 2006**

Related U.S. Patent Documents

Reissue of:

- (64) Patent No.: **6,819,080**
- Issued: **Nov. 16, 2004**
- Appl. No.: **10/292,007**
- Filed: **Nov. 9, 2002**

| | | |
|-------------|---------|-----------------|
| 3,781,631 A | 12/1973 | Nelson et al. |
| 3,809,882 A | 5/1974 | Wetmore |
| 3,840,785 A | 10/1974 | Roszyk et al. |
| 3,885,211 A | 5/1975 | Gutai |
| 3,976,986 A | 8/1976 | Zabroski |
| 4,029,954 A | 6/1977 | Moyer |
| 4,150,302 A | 4/1979 | Roche |
| 4,177,500 A | 12/1979 | Nicholl et al. |
| 4,214,185 A | 7/1980 | Breeze |
| 4,223,232 A | 9/1980 | Bulat |
| 4,244,011 A | 1/1981 | Hammel et al. |
| 4,374,354 A | 2/1983 | Petrovic et al. |
| 4,383,212 A | 5/1983 | Ballman |
| 4,463,283 A | 7/1984 | Penney et al. |
| 4,605,993 A | 8/1986 | Zelina, Jr. |
| 4,647,831 A | 3/1987 | O'Malley et al. |
| 4,716,352 A | 12/1987 | Hurn et al. |
| 4,739,242 A | 4/1988 | McCarty et al. |
| 4,754,376 A | 6/1988 | Winslow |
| 4,764,853 A | 8/1988 | Thomas et al. |

(Continued)

U.S. Applications:

- (63) Continuation-in-part of application No. 09/885,848, filed on Jun. 20, 2001, now Pat. No. 6,479,965.

- (51) **Int. Cl.**
H01M 10/46 (2006.01)

- (52) **U.S. Cl.** **320/107; 320/114**

- (58) **Field of Classification Search** **320/107, 320/108, 109, 110, 112-116; 362/20, 447, 362/806**

See application file for complete search history.

- (56) **References Cited**

U.S. PATENT DOCUMENTS

| | | | | | |
|-------------|---|---------|----------------|-------|---------|
| 3,217,224 A | * | 11/1965 | Sherwood | | 320/115 |
| 3,277,358 A | | 10/1966 | Nicholl | | |
| 3,373,274 A | | 3/1968 | Kott | | |
| 3,418,552 A | | 12/1968 | Holmes | | |
| 3,517,185 A | | 6/1970 | Moore et al. | | |
| 3,576,990 A | | 5/1971 | Johnson et al. | | |
| 3,641,336 A | | 2/1972 | Boin | | |
| 3,746,877 A | | 7/1973 | Seiter et al. | | |

FOREIGN PATENT DOCUMENTS

| | | |
|----|-----------|---------|
| DE | 4220148 | 12/1993 |
| JP | 05-168175 | 7/1993 |

Primary Examiner—Edward Tso

(74) *Attorney, Agent, or Firm*—Seyfarth Shaw LLP

(57) **ABSTRACT**

An autoilluminating rechargeable lamp system includes a set of one or more self-standing rechargeable lighting fixtures (luminaries) removably supported on a recharging and support member. The luminaries each include a light diffuser that may resemble a candle that turn on when removed from the recharging and support member. The luminaries may also turn on when power to the recharging and support member is turned off, turning the luminaries on automatically as during a power failure. The luminaries may each be inductively coupled to the recharging and support member, which enables to provide an aesthetically pleasing interface free of electrical contacts.

24 Claims, 13 Drawing Sheets

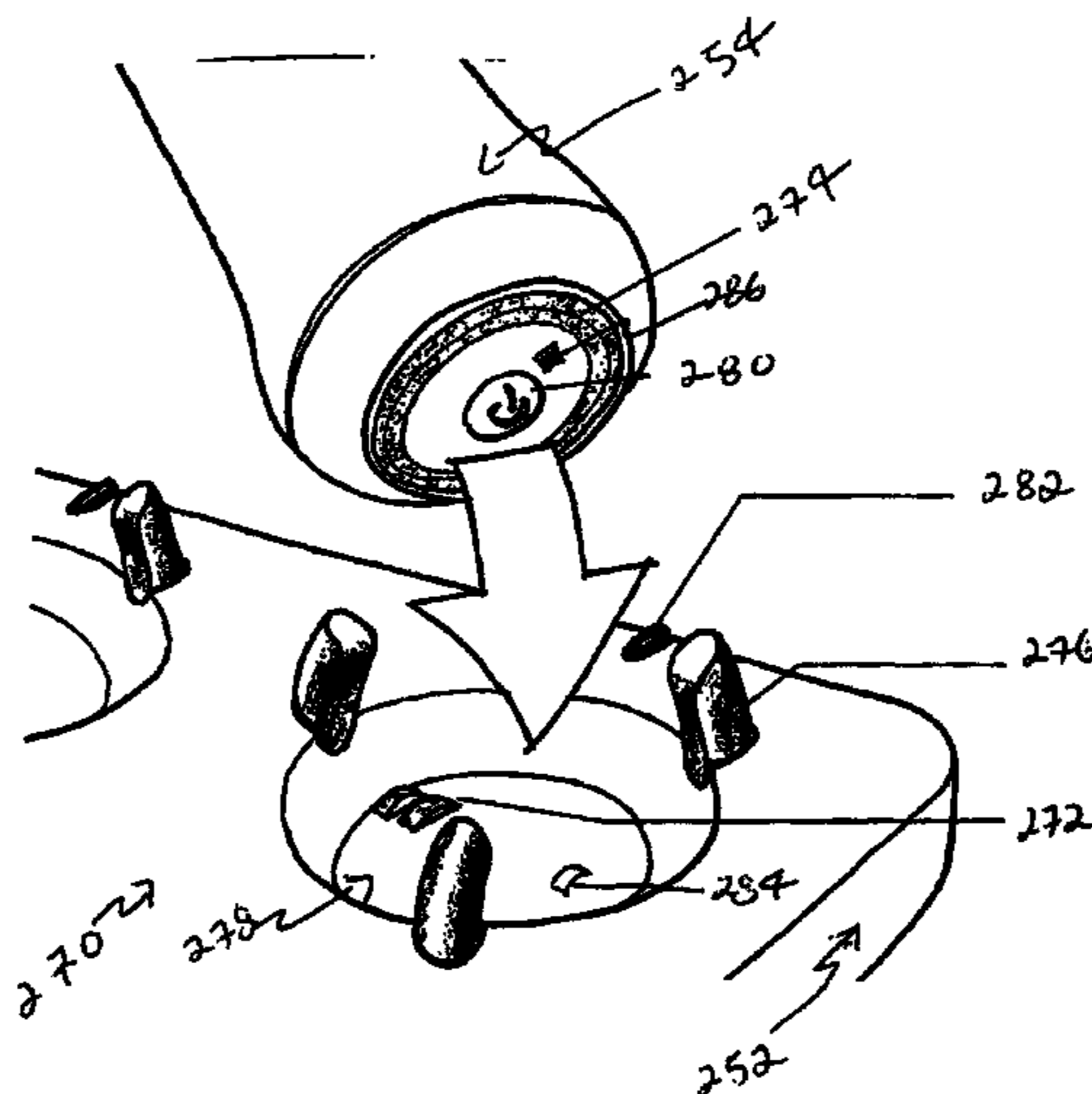

US RE41,628 E

Page 2

| U.S. PATENT DOCUMENTS | | | | | | |
|-----------------------|----|--------------------------------------|--------------|----|---------|--------------------|
| | | | 6,633,152 | B2 | 10/2003 | Sharrah et al. |
| | | | 6,634,768 | B2 | 10/2003 | McKenzie et al. |
| 4,827,245 | A | 5/1989 Lipman | 6,652,115 | B2 | 11/2003 | Sharrah |
| 5,010,454 | A | 4/1991 Hopper | 6,659,621 | B2 | 12/2003 | Sharrah et al. |
| 5,039,929 | A | 8/1991 Veistroffer et al. | D485,390 | S | 1/2004 | Stancik et al. |
| 5,055,986 | A | 10/1991 Johnson | D486,787 | S | 2/2004 | Krieger et al. |
| 5,124,532 | A | 6/1992 Hafey et al. | D495,819 | S | 9/2004 | Krieger et al. |
| 5,233,271 | A | 8/1993 Huang | 6,819,080 | B2 | 11/2004 | Barbeau et al. |
| 5,365,145 | A | 11/1994 Fields | 6,851,820 | B2 | 2/2005 | Choi et al. |
| 5,392,162 | A | 2/1995 Glucksman | 6,900,595 | B2 | 5/2005 | Cojocary |
| 5,399,089 | A | 3/1995 Eickman et al. | 6,909,260 | B2 | 6/2005 | Parker |
| 5,426,347 | A | 6/1995 Nilssen | 6,911,917 | B2 | 6/2005 | Higgs |
| 5,471,129 | A | 11/1995 Mann | 6,945,664 | B1 | 9/2005 | Frieling et al. |
| 5,473,517 | A | 12/1995 Blackman | 6,986,589 | B2 | 1/2006 | Evans et al. |
| 5,535,108 | A | 7/1996 Logsdon | 7,006,002 | B2 | 2/2006 | Shomali |
| 5,550,452 | A | 8/1996 Shirai et al. | 7,011,426 | B2 | 3/2006 | Gabor |
| 5,558,429 | A | 9/1996 Cain | 7,029,146 | B2 | 4/2006 | Kitchen |
| 5,662,406 | A | 9/1997 Mattice et al. | 7,071,625 | B2 | 7/2006 | Ceng et al. |
| 5,734,229 | A | 3/1998 Bavaro et al. | 7,125,145 | B2 | 10/2006 | Gardner et al. |
| 5,748,080 | A | 5/1998 Clay | 2002/0064041 | A1 | 5/2002 | Parker |
| 5,754,124 | A | 5/1998 Daggett et al. | 2003/0090892 | A1 | 5/2003 | Su |
| 5,801,513 | A | 9/1998 Smith et al. | 2003/0141819 | A1 | 7/2003 | Cojocary |
| 5,844,474 | A | * 12/1998 Saling et al. 340/440 | 2003/0142501 | A1 | 7/2003 | Exilien |
| 5,900,715 | A | 5/1999 Roberts | 2004/0037069 | A1 | 2/2004 | Blackbourn |
| 5,908,233 | A | 6/1999 Heskett et al. | 2004/0160769 | A1 | 8/2004 | Currie et al. |
| 6,000,811 | A | 12/1999 Bordak | 2004/0184273 | A1 | 9/2004 | Reynolds et al. |
| 6,016,046 | A | 1/2000 Kaite et al. | 2004/0252492 | A1 | 12/2004 | Peterson |
| 6,034,505 | A | 3/2000 Arthur et al. | 2005/0194930 | A1 | 9/2005 | Barbeau et al. |
| 6,040,680 | A | 3/2000 Toya et al. | 2005/0196716 | A1 | 9/2005 | Haab et al. |
| 6,040,780 | A | 3/2000 Lucas | 2005/0239007 | A1 | 10/2005 | Dell'Aquila et al. |
| 6,102,549 | A | 8/2000 Thomas et al. | 2005/0264261 | A1 | 12/2005 | Barbeau et al. |
| 6,107,744 | A | 8/2000 Bavaro et al. | 2005/0284856 | A1 | 12/2005 | Cafaro et al. |
| 6,179,438 | B1 | 1/2001 Parker | 2006/0034078 | A1 | 2/2006 | Kovacik et al. |
| 6,186,641 | B1 | 2/2001 Parker | 2006/0062019 | A1 | 3/2006 | Young |
| RE37,092 | E | 3/2001 Sharrah et al. | 2006/0072306 | A1 | 4/2006 | Woodyard |
| 6,238,061 | B1 | 5/2001 McKenzie | 2006/0082988 | A1 | 4/2006 | Riblett et al. |
| 6,243,276 | B1 | 6/2001 Neumann | 2006/0103543 | A1 | 5/2006 | Chen et al. |
| 6,268,027 | B1 | 7/2001 Wu | 2006/0120069 | A1 | 6/2006 | West |
| 6,479,965 | B2 | 11/2002 Barbeau et al. | 2006/0133089 | A1 | 6/2006 | Reid et al. |
| 6,536,917 | B1 | 3/2003 Aperocho et al. | 2006/0139927 | A1 | 6/2006 | Kovacik et al. |
| 6,554,445 | B1 | 4/2003 Jacoby | 2006/0171143 | A1 | 8/2006 | Yuen |
| 6,599,001 | B2 | 7/2003 Johnson | | | | |
| 6,605,900 | B2 | 8/2003 Chien | | | | |

* cited by examiner

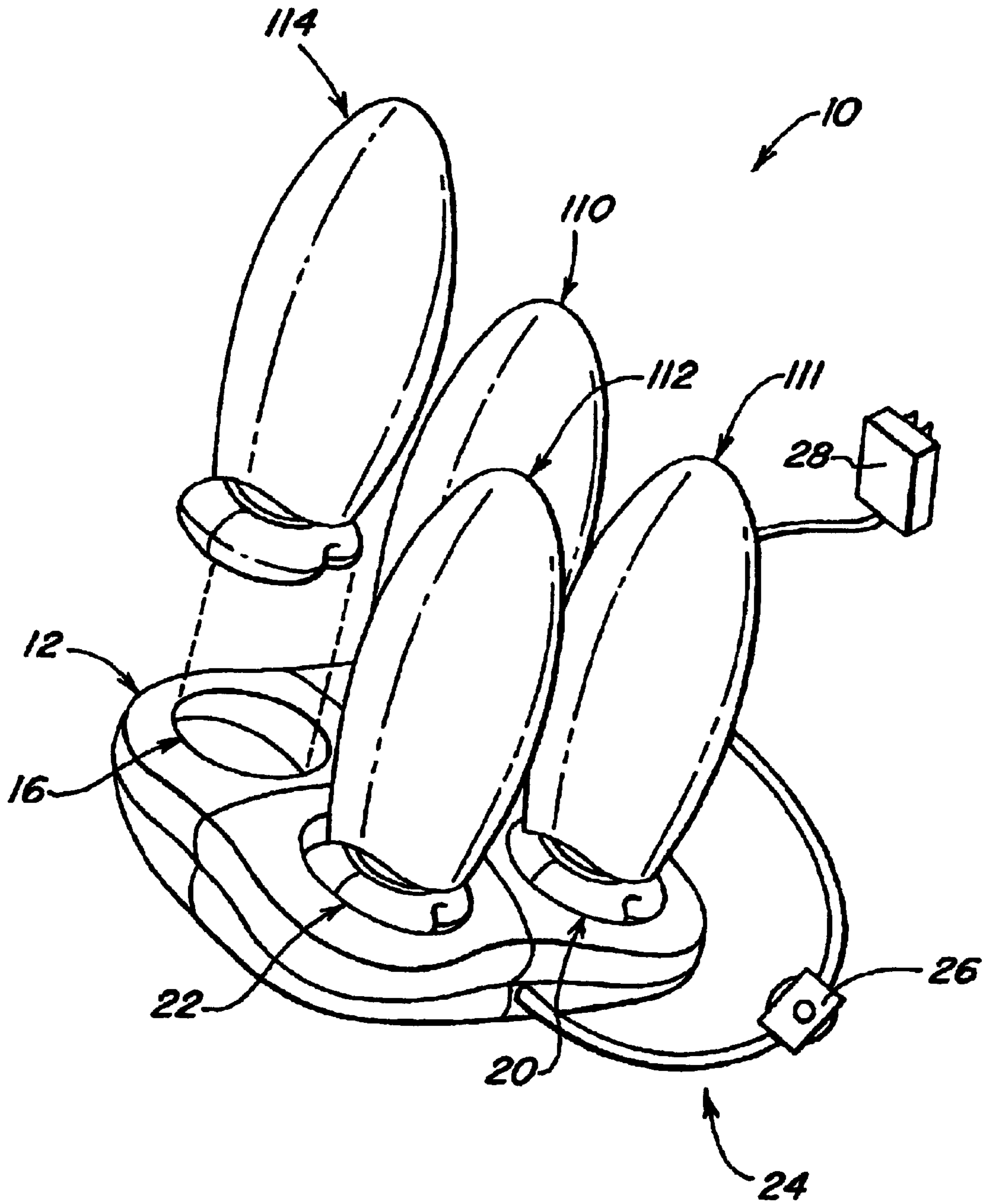

FIG. 1

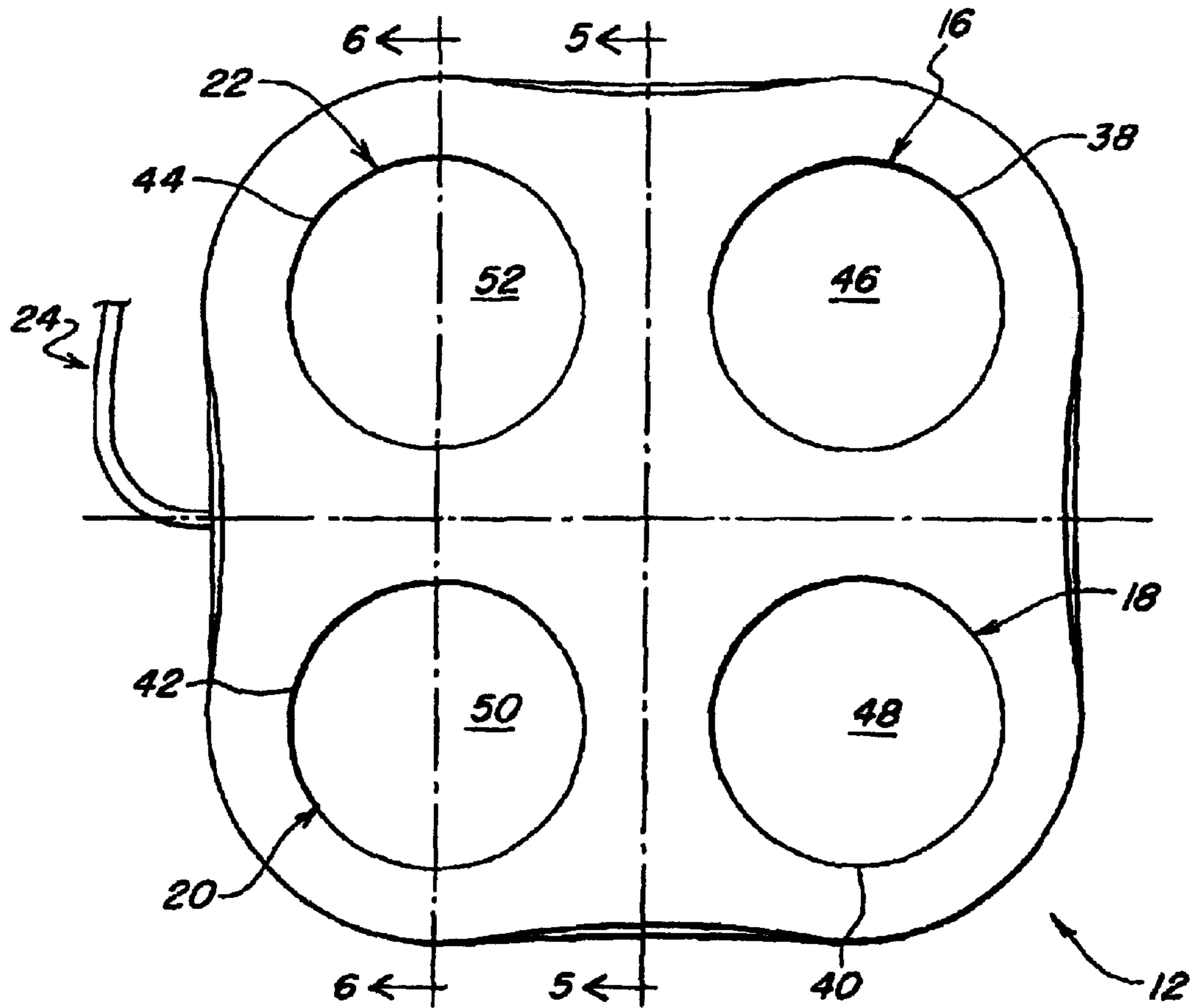

FIG. 2

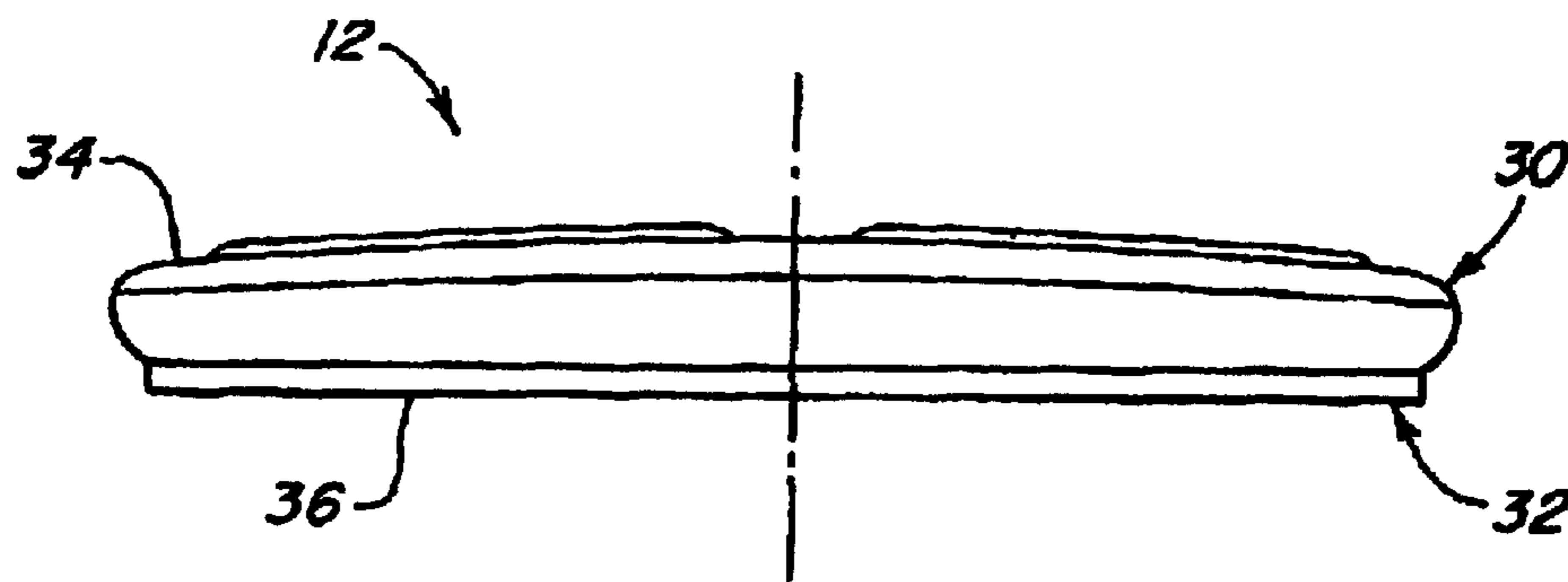

FIG. 3

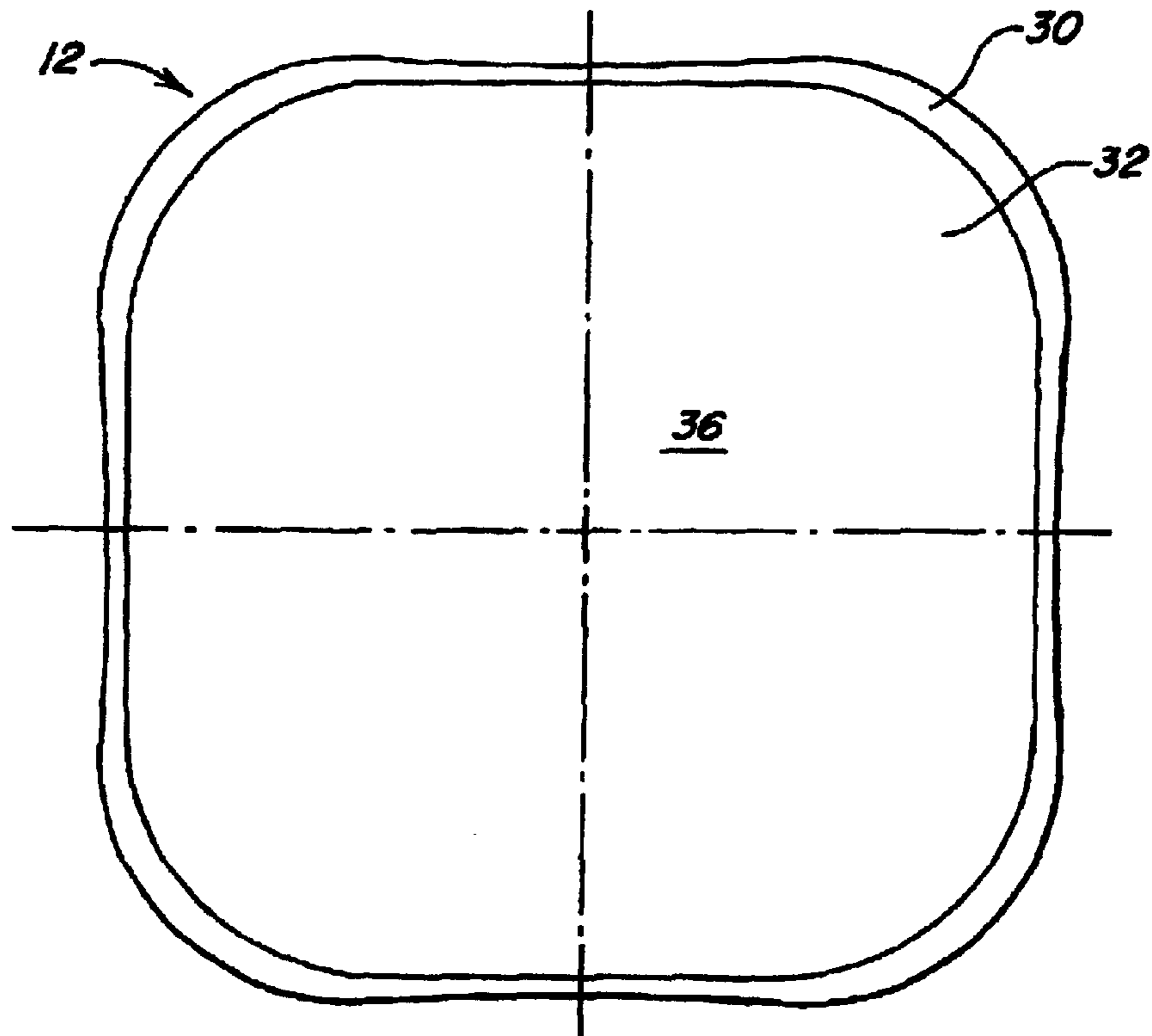

FIG. 4

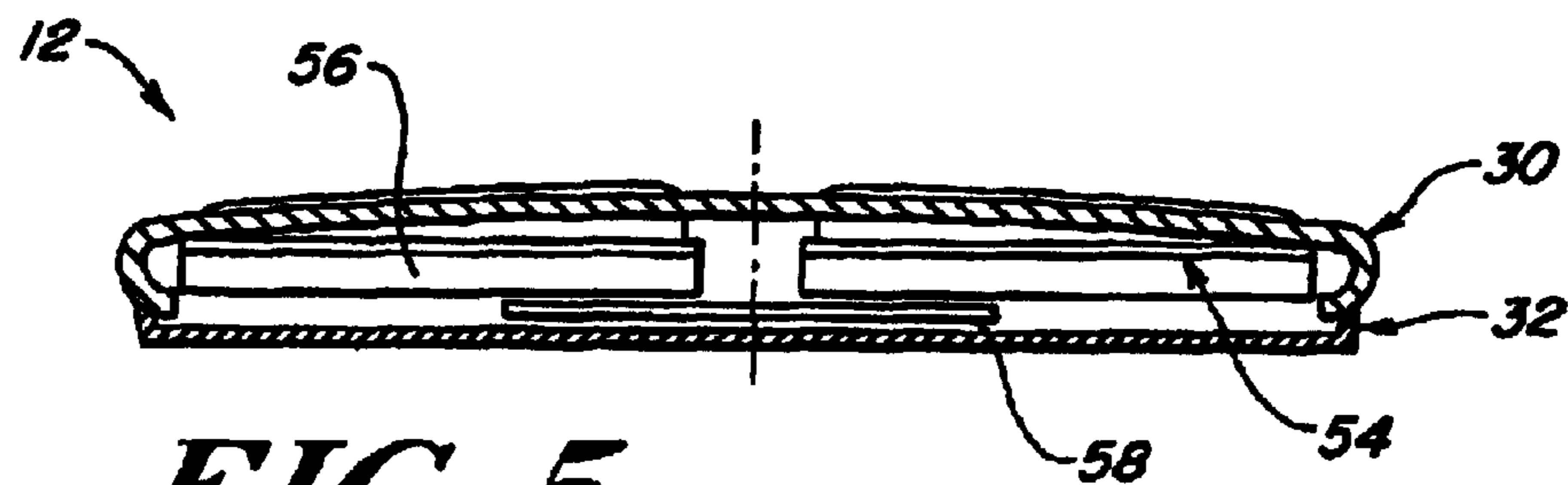

FIG. 5

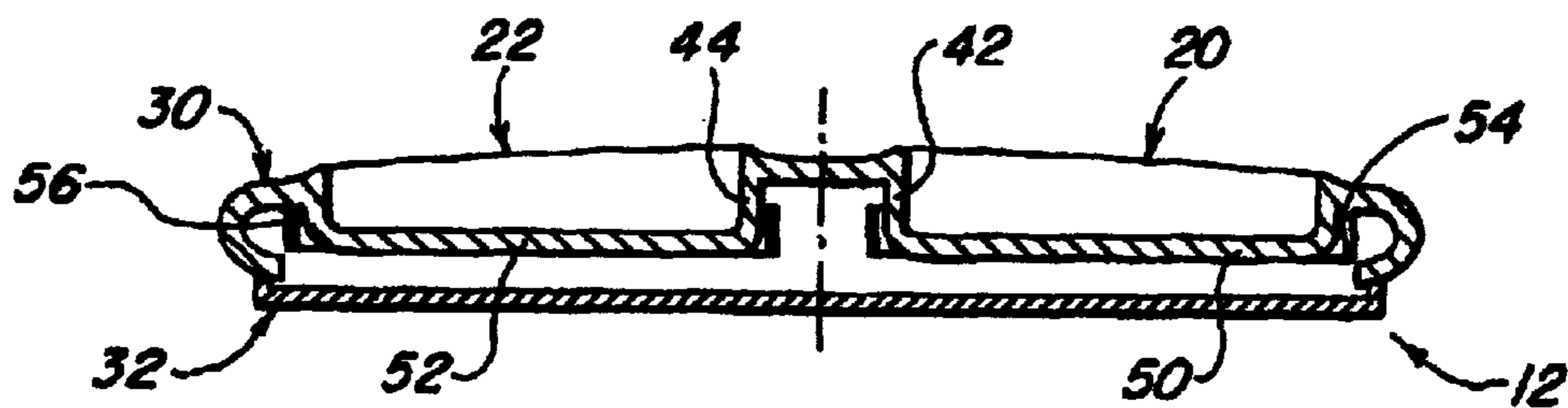

FIG. 6

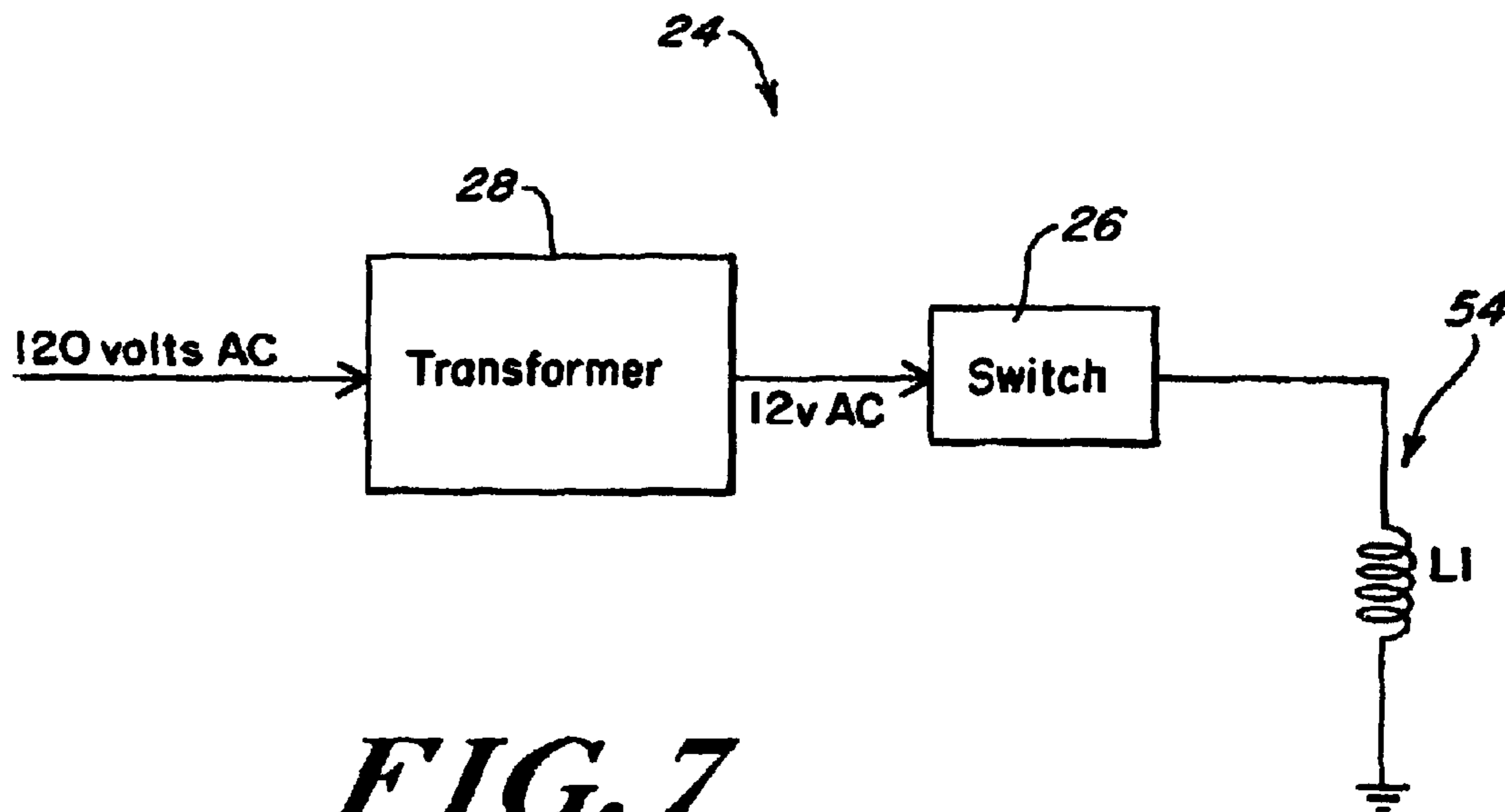

FIG. 7

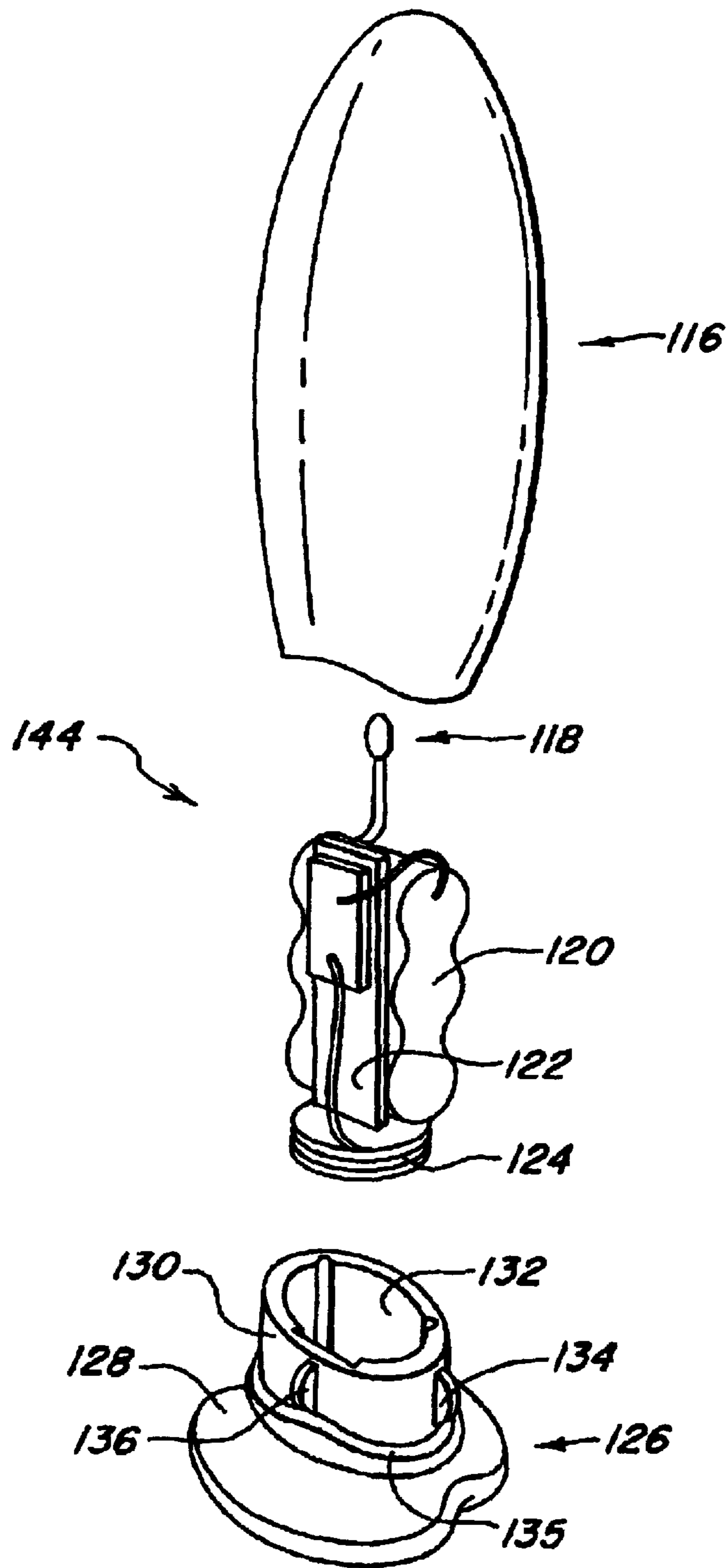

FIG. 8

FIG. 11

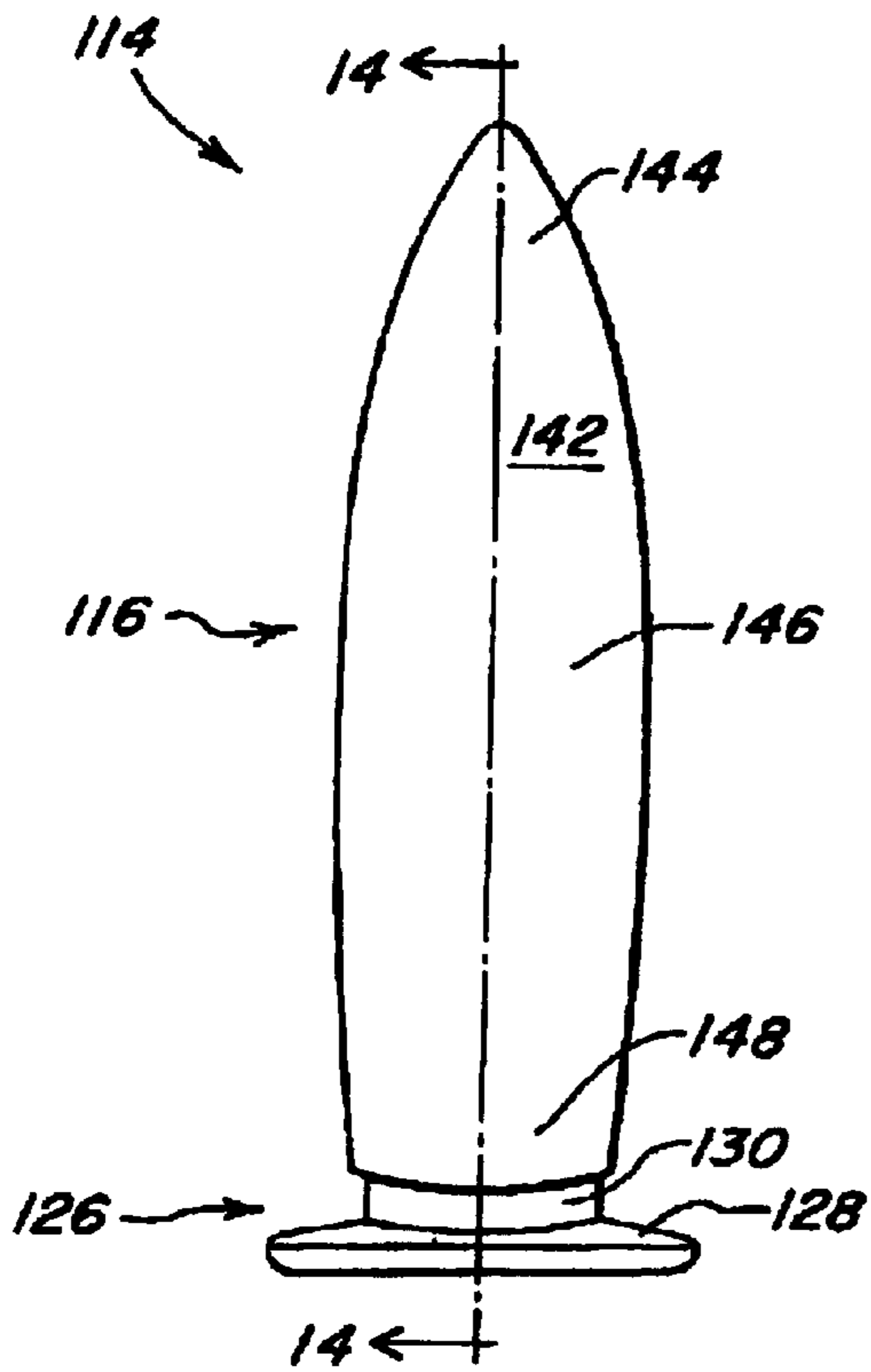
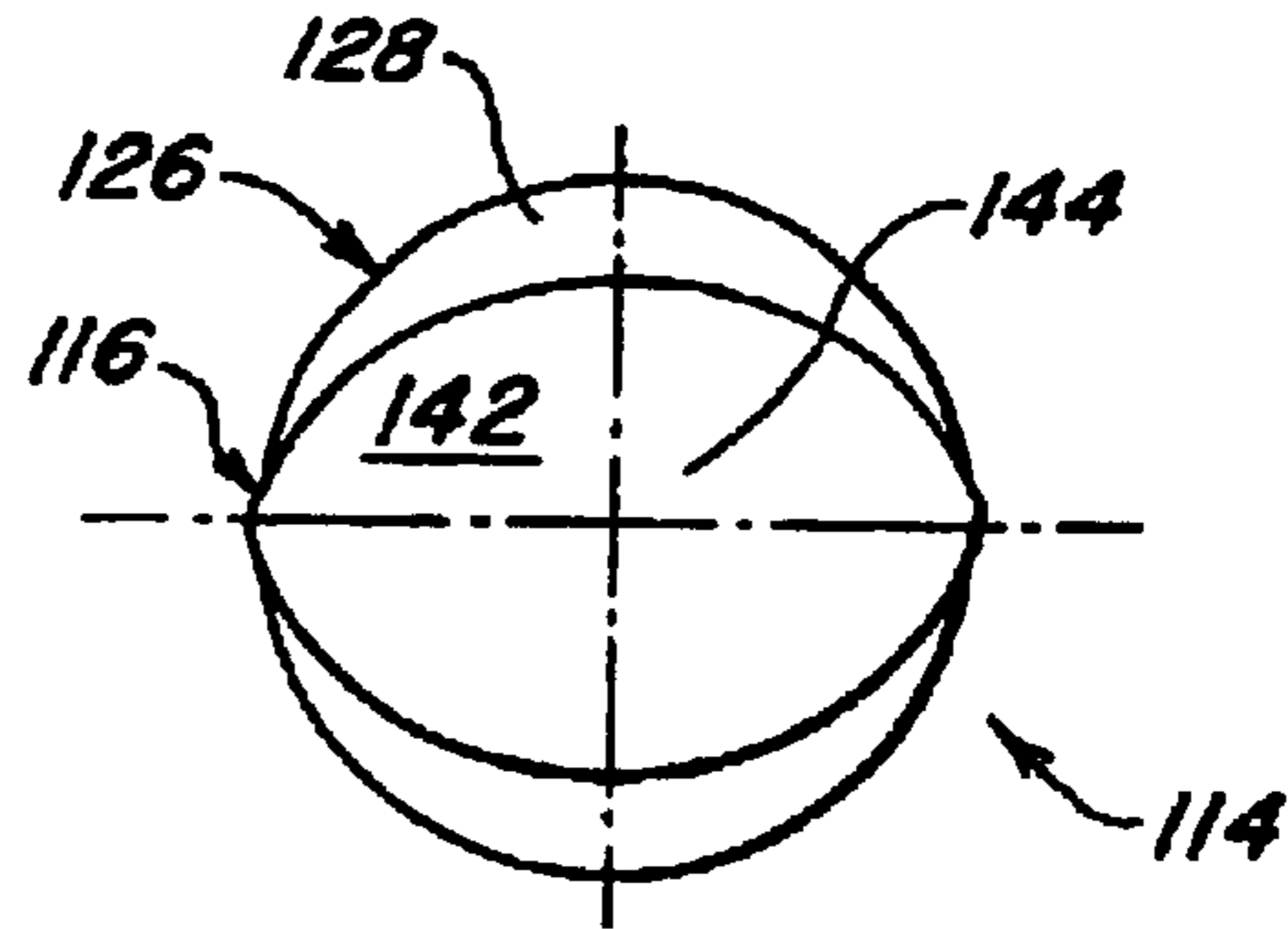

FIG. 10

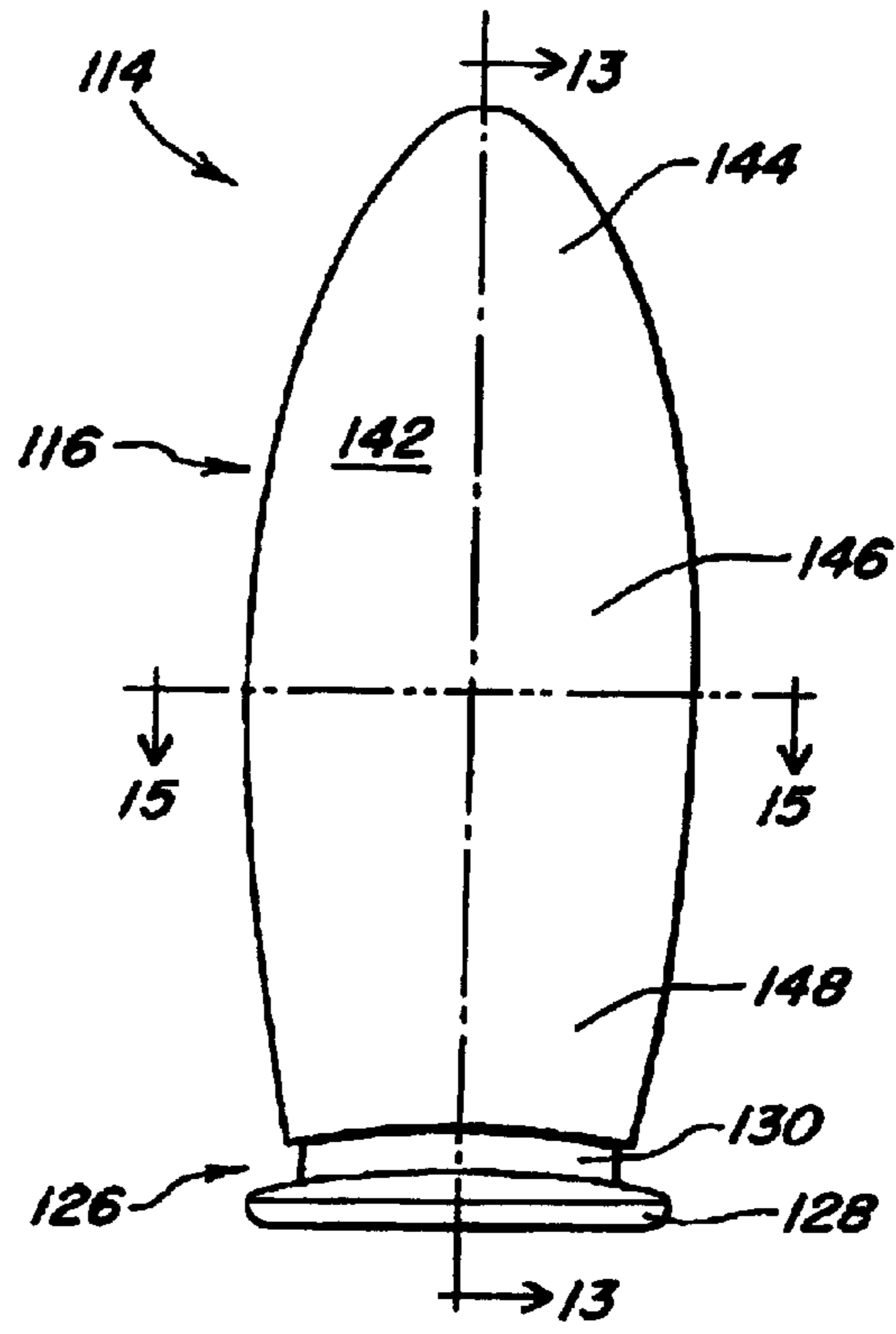

FIG. 9

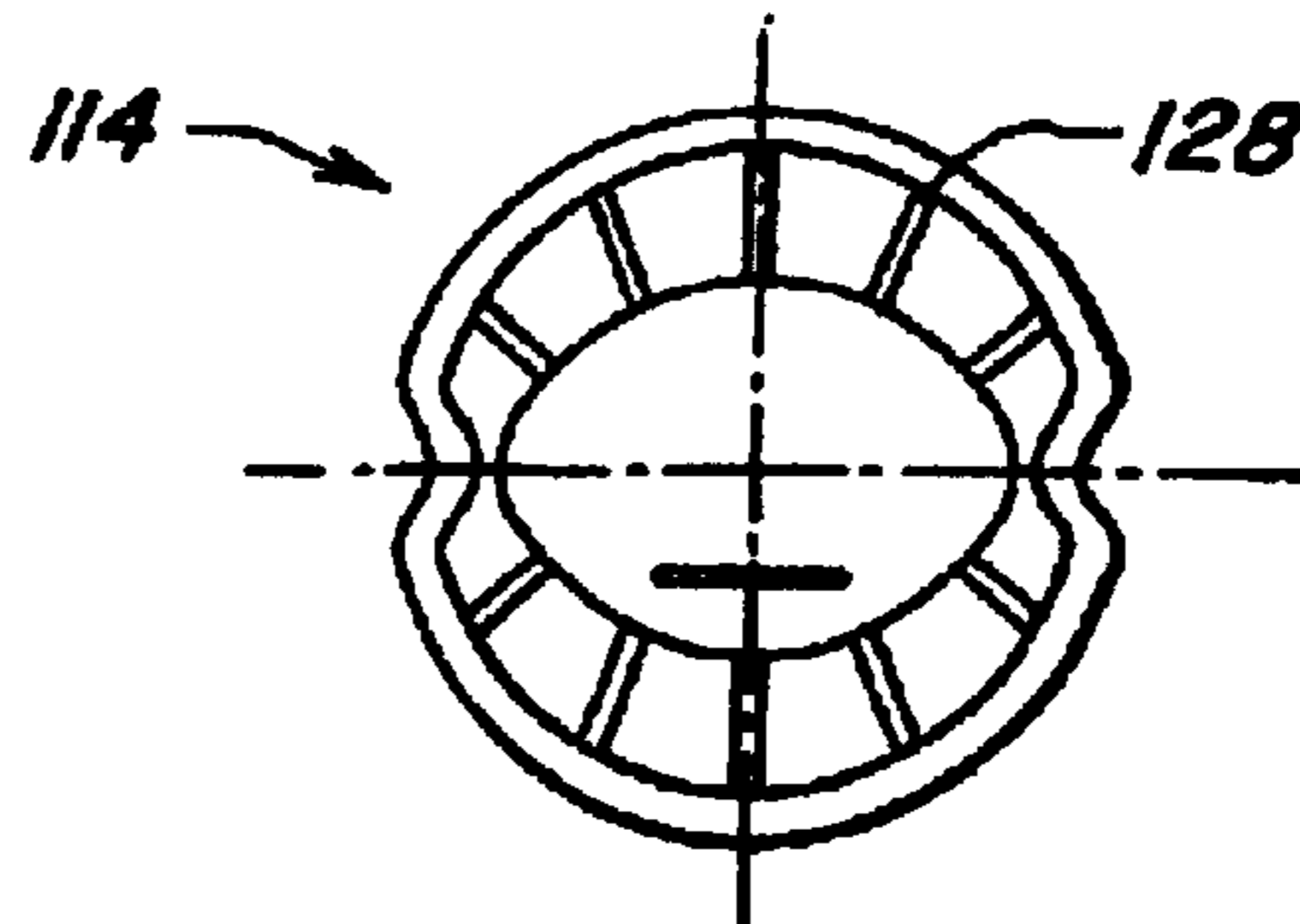

FIG. 12

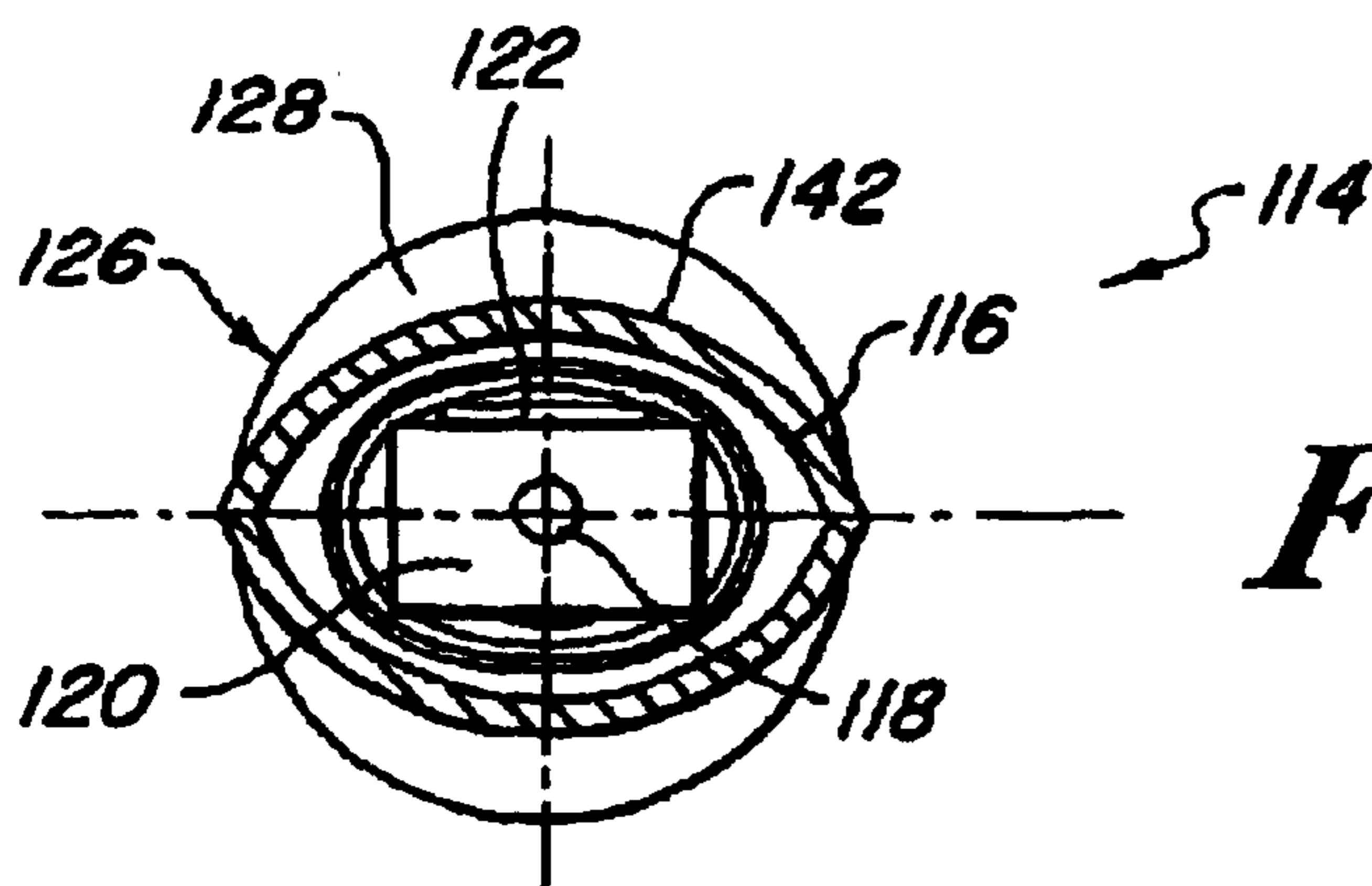

FIG. 15

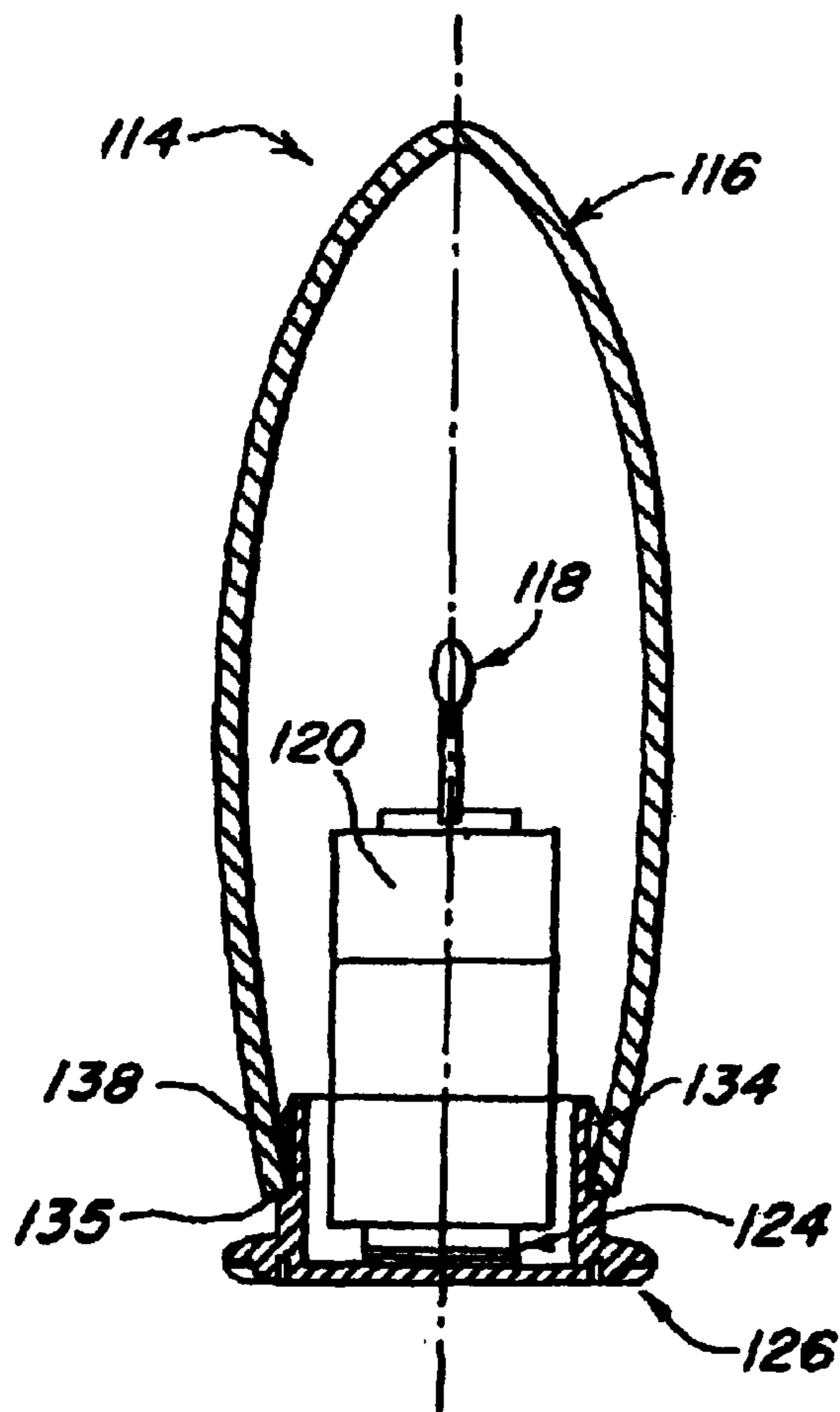

FIG. 14

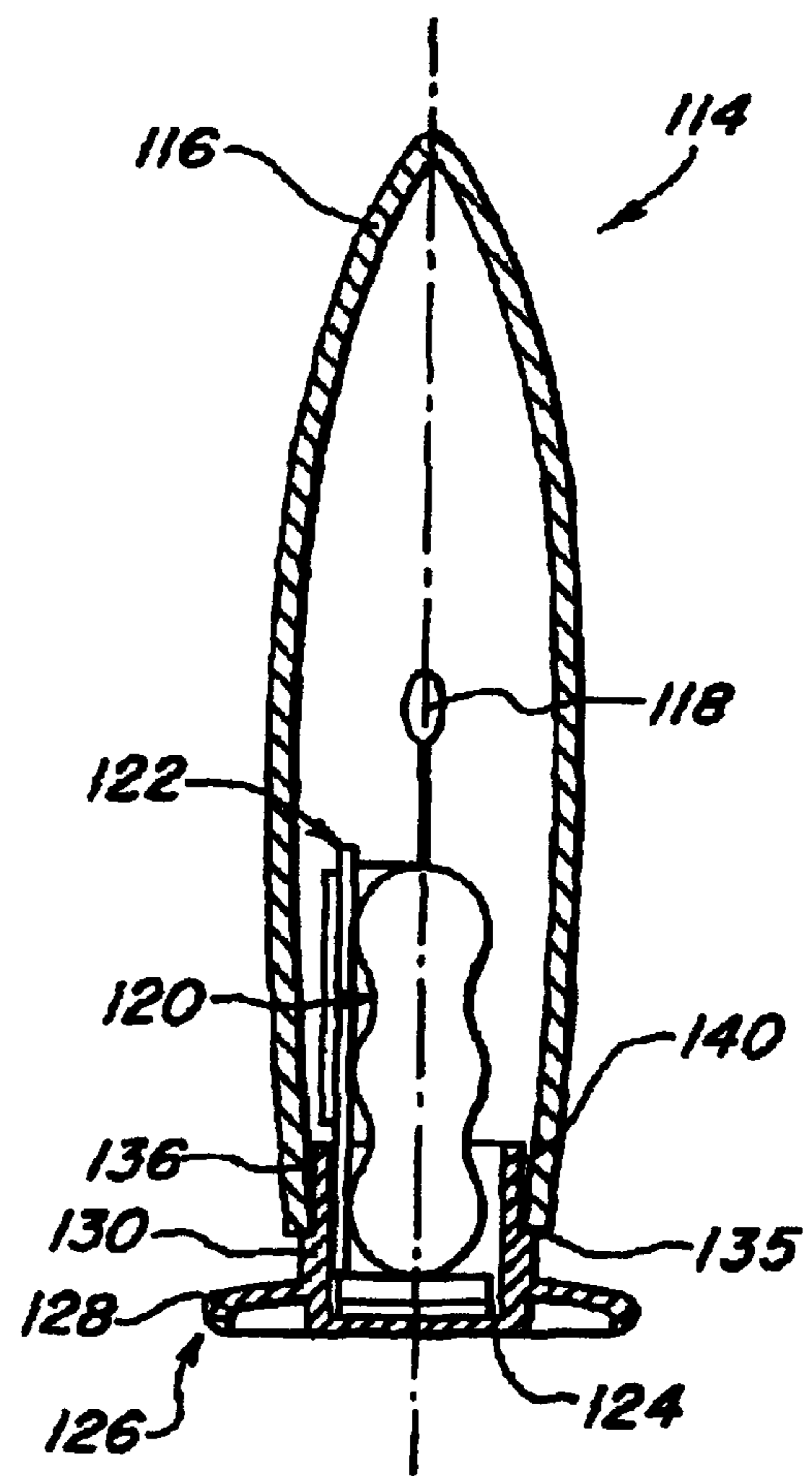
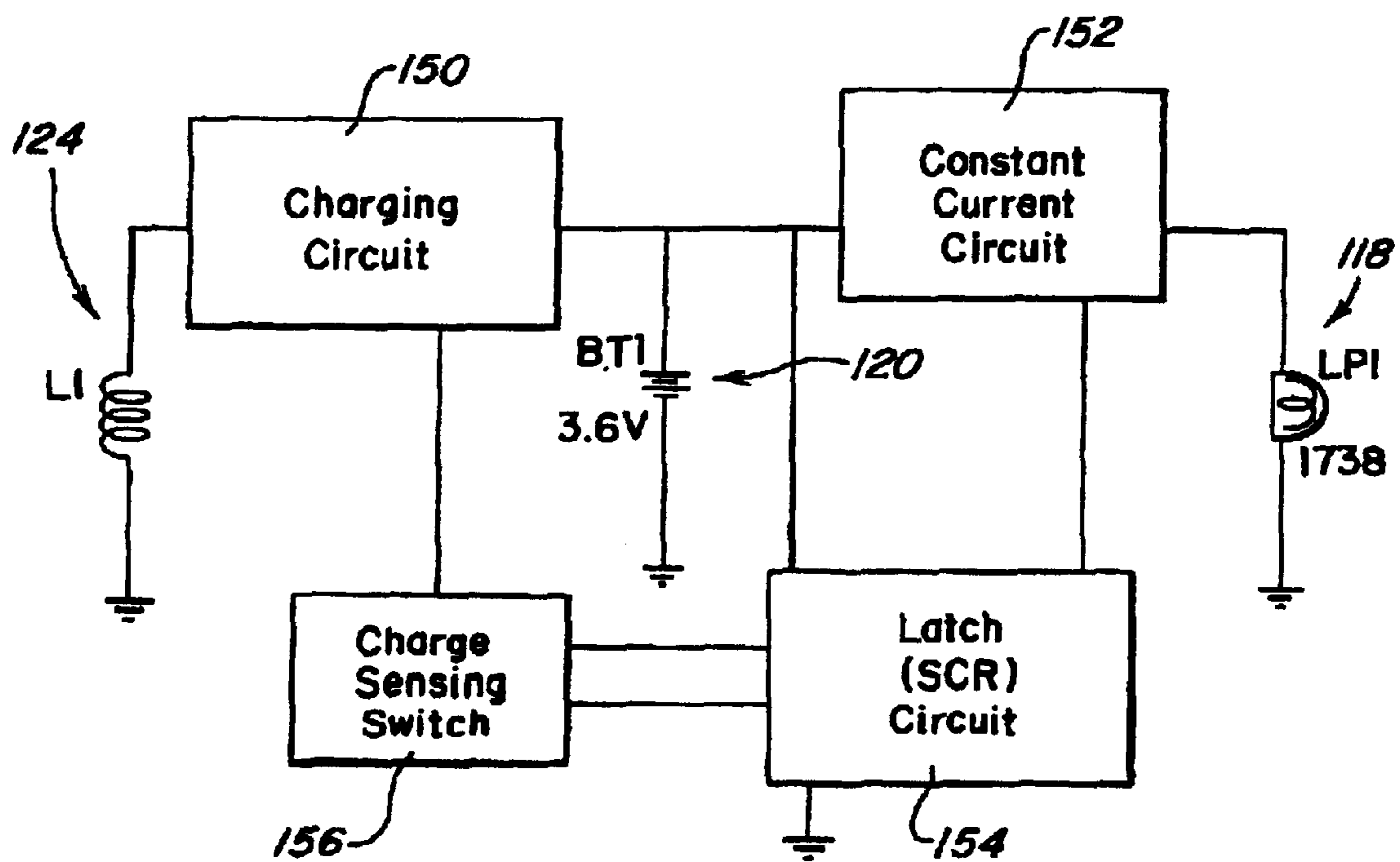

FIG. 13



122

FIG. 16

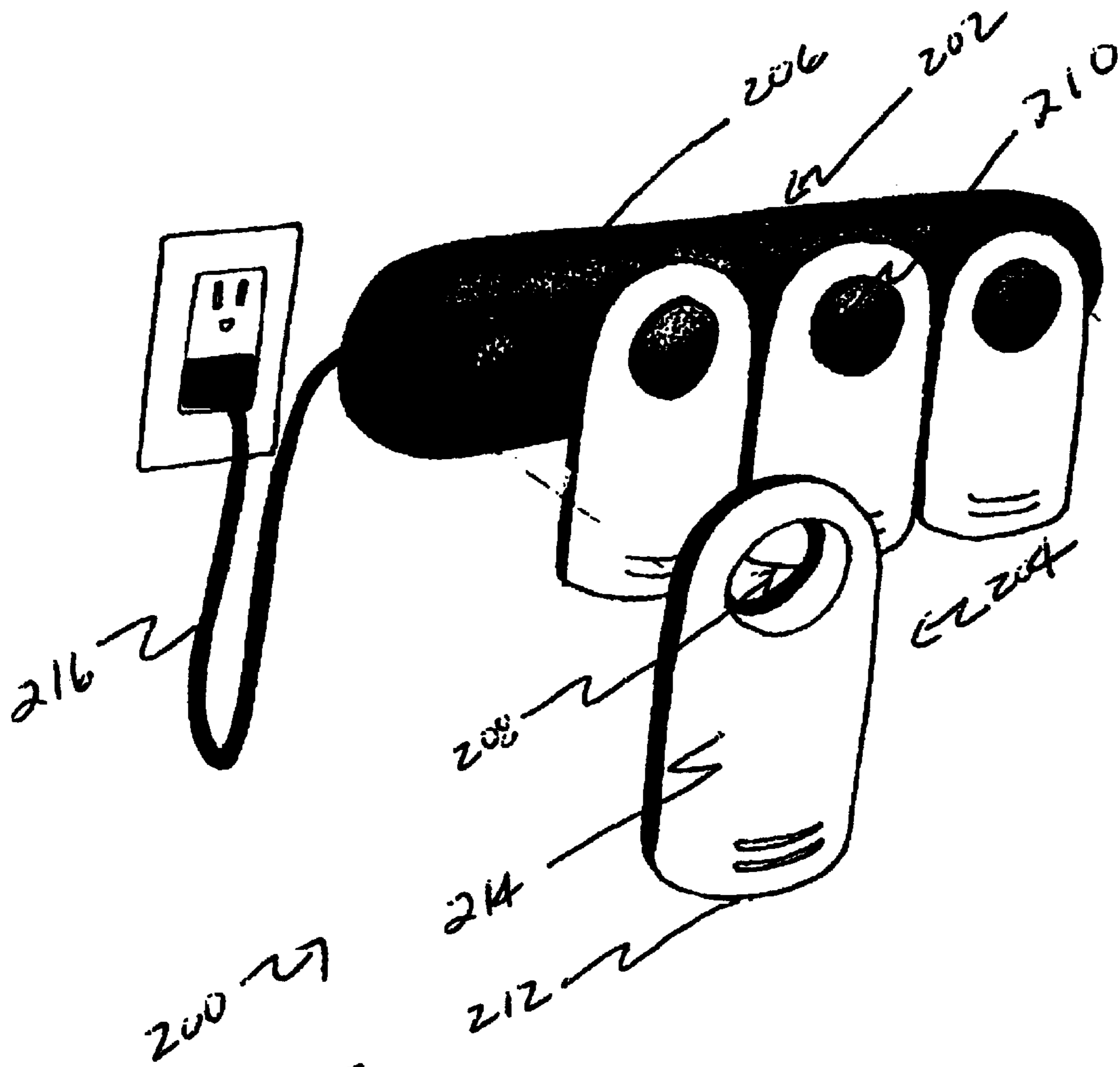

FIG. 17

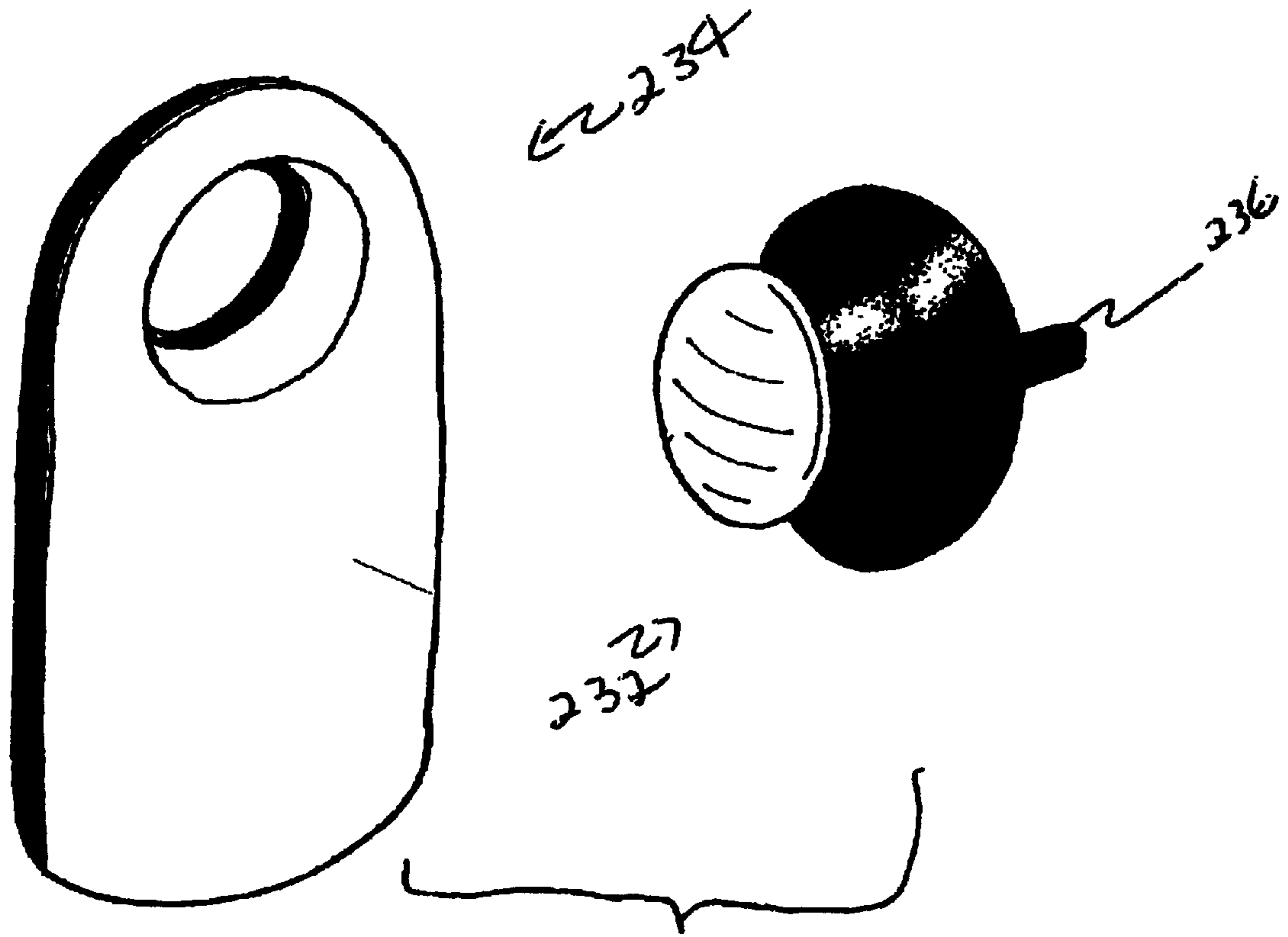

FIG. 18

230 27

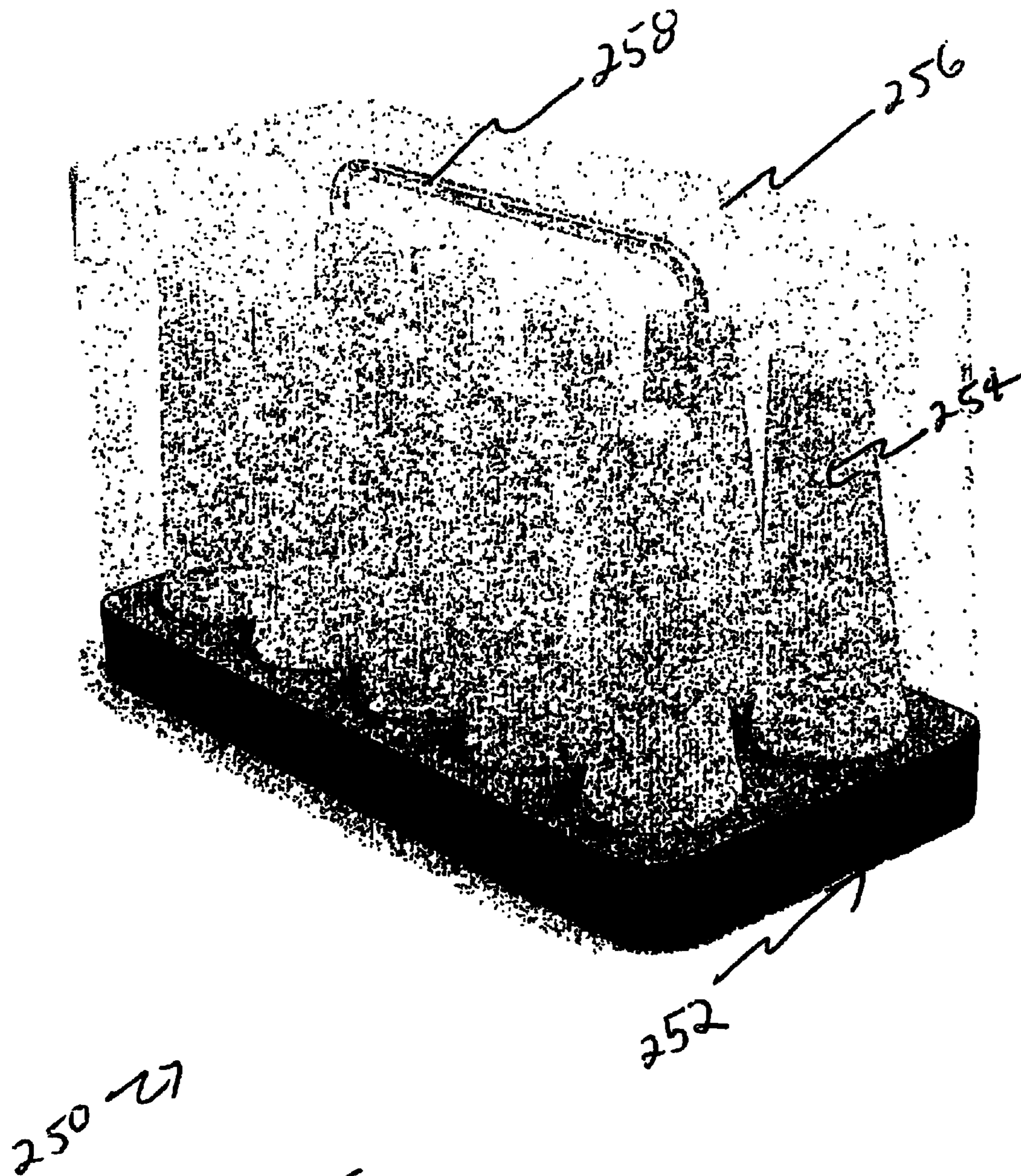

FIG. 19

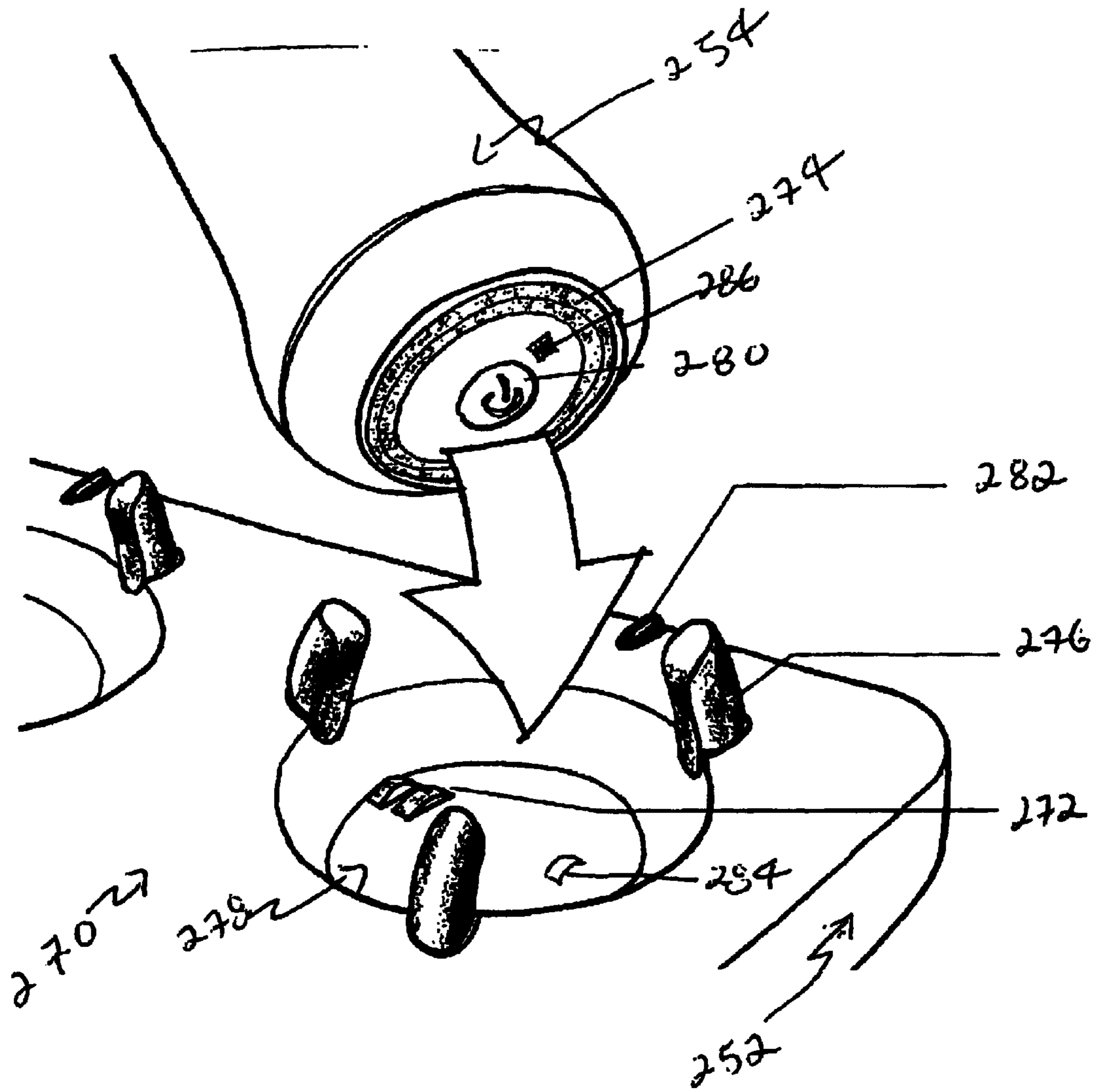
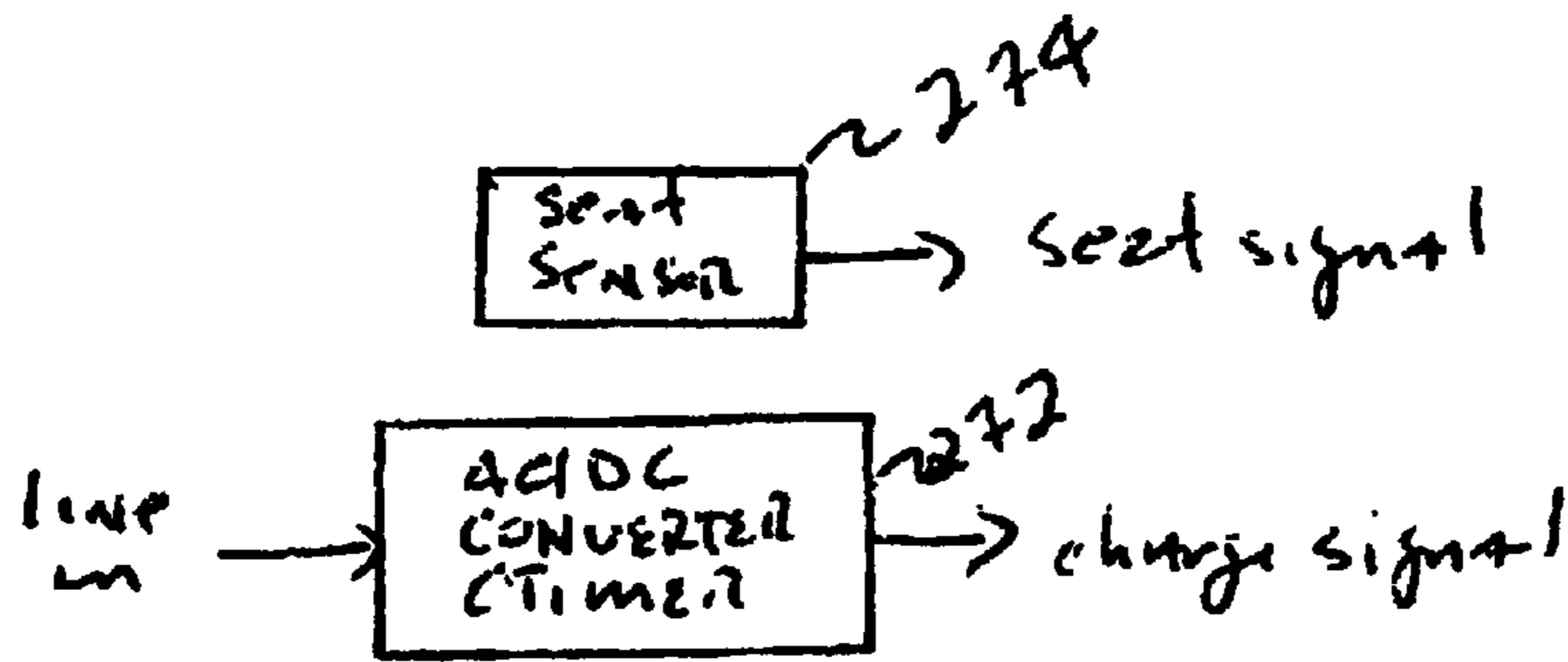
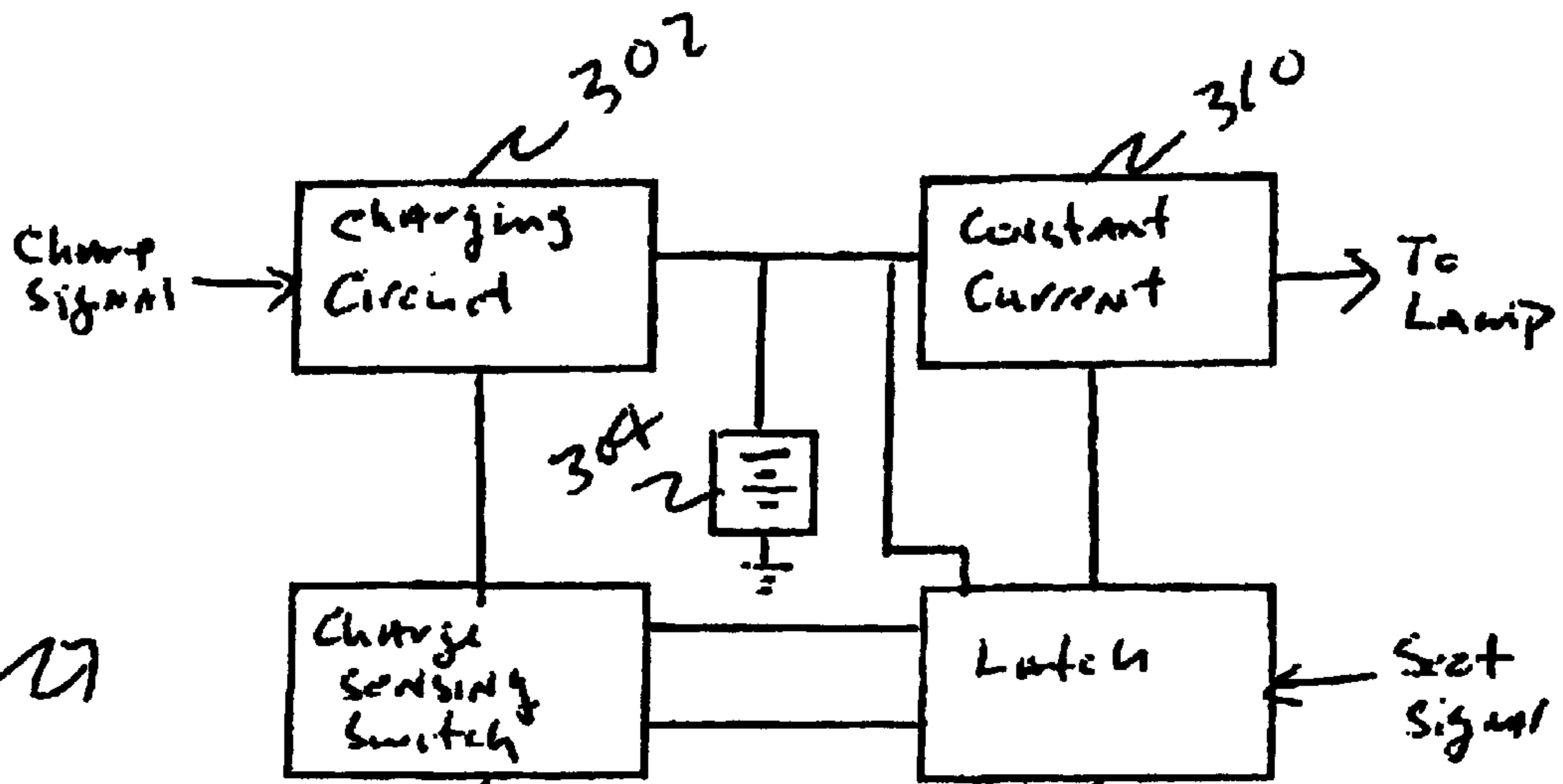

FIG. 20



270 ~>
 fig. 21



300 ~>
 308 ~>
 fig. 22

AUTOILLUMINATING LAMP SYSTEM

Matter enclosed in heavy brackets [] appears in the original patent but forms no part of this reissue specification; matter printed in italics indicates the additions made by reissue.

CROSS-REFERENCE TO RELATED APPLICATIONS

The present invention is a continuation-in-part of allowed U.S. utility patent application Ser. No. 09/885,848 filed Jun. 20, 2001 of the same inventive entity as herein, now U.S. Pat. No. 6,479,965, incorporated herein by reference.

FIELD OF THE INVENTION

The present invention is drawn to the field of illumination, and more particularly, to a novel rechargeable lamp system.

BACKGROUND OF THE INVENTION

Candles may be moved and placed to provide illumination and/or ambience. While their utilitarian and aesthetic advantages are well-known, candles suffer from an undesirable self-consumption, needing to be replaced when used-up; produce smoke especially when snuffed, which may foul the air; require vigilant attendance to mitigate an ever-present fire hazard; are susceptible to being extinguished by gusts of air when used outdoors or moved around; and may give rise to undesirable wax build-up, which in many instances needs removed from candle support members or underlying structures.

There is thus a need to provide a rechargeable lamp system that enjoys the many utilitarian and aesthetic advantages of candles but is not subject to their disadvantages.

SUMMARY OF THE INVENTION

It is accordingly a general object of the present invention to disclose a rechargeable lamp system that provides candle-like lighting for indoor or outdoor use that avoids the problems associated with candles.

In accordance therewith, the autoilluminating rechargeable lamp system of the present invention includes a recharging platter adapted to receive a set of luminaries including a first circuit coupled to each luminary of said set of luminaries received thereon operative in response to supplied AC power to provide a charge signal to each luminary of said set of luminaries received thereon; and a set of luminaries each having a light emitting element connected to a rechargeable battery pack via a second circuit operative in one mode to charge said rechargeable battery pack in response to said charge signal when each luminary of said set of luminaries is received on said recharging platter and operative in another mode to activate said light emitting element in response to the absence of said signal, whereby, each said luminary lights if removed from said recharging platter and lights if no AC power is supplied to said recharging platter when received therein.

In the presently preferred embodiments, the set of luminaries includes one or more luminaries each of which is inductively coupled to the first circuit of the recharging platter. The inductive coupling provides automatic, hands-free recharging of the rechargeable battery pack of a luminary upon its receipt by the recharging platter, and provides automatic, hands-free actuation of a luminary when it is removed therefrom.

In the presently preferred embodiments, each luminary of the set of luminaries is self-standing and includes a diffusor

that may be shaped to resemble a candle releasably mounted to a base member supporting said light emitting element therewithin.

In further accordance therewith, the autoilluminating rechargeable lamp system of the present invention includes a wall mountable charging base adapted to support a set of luminaries including a first circuit coupled to each luminary of said set of luminaries supported thereon operative in response to supplied AC power to provide a charge signal to each luminary of said set of luminaries supported thereon; and a set of luminaries each having a light emitting element connected to a rechargeable battery pack via a second circuit operative in one mode to charge said rechargeable battery pack in response to said charge signal when each luminary of said set of luminaries is supported thereon and operative in another mode to activate said light emitting element in response to the absence of said signal, whereby, each said luminary lights if removed from said wall mountable charging base and lights if no AC power is supplied to said wall mountable charging base when supported thereon.

In the presently preferred embodiments, the wall mountable charging base may be plugged directly into an AC wall outlet and/or mounted adjacent an AC wall outlet by any suitable mounting hardware.

In further accordance therewith, the autoilluminating rechargeable lamp system of the present invention includes a charging base adapted to support a set of luminaries including a first circuit coupled to each luminary of said set of luminaries supported thereon operative in response to supplied AC power to provide a charge signal to each luminary of said set of luminaries supported thereon; a sensor to provide a seat signal representative that each luminary of said set of luminaries is supported on said charging base; and a set of luminaries each having a light emitting element connected to a rechargeable battery pack via a second circuit operative in one mode to charge said rechargeable battery pack in response to said charge signal when each luminary of said set of luminaries is supported thereon and operative in another mode to activate said light emitting element in response to the absence of said seat signal, whereby, each said luminary lights if removed from said charging base and does not light if no AC power is supplied to said charging base when supported thereon.

In the presently preferred embodiments, the charging base maybe provided with a removable cover that protects the luminaries during charging, storage, and a handle that aids in transit.

BRIEF DESCRIPTION OF THE DRAWINGS

These and other objects, advantageous features and inventive aspects of the present invention will be more fully appreciated as the same becomes better understood from the following detailed description of the preferred embodiments when considered in connection with the accompanying drawings, in which:

FIG. 1 is a perspective view of an exemplary embodiment of the present invention, showing a charging stand and one lamp module;

FIG. 2 is a top view of the charging stand;

FIG. 3 is a front view of the charging stand;

FIG. 4 is a bottom view of the charging stand;

FIG. 5 is a sectional view of the charging stand, taken along line 5—5 of FIG. 2;

FIG. 6 is a sectional view of the charging stand, taken along line 6—6 of FIG. 2;

FIG. 7 is a circuit diagram of the charging stand circuit;

FIG. 8 is an exploded perspective view of an exemplary embodiment of a lamp module according to the present invention;

FIG. 9 is a front view of the lamp module;

FIG. 10 is a right side view of the lamp module;

FIG. 11 is a top view of the lamp module;

FIG. 12 is a bottom view of the lamp module;

FIG. 13 is a sectional view of the lamp module taken along line 13—13 of FIG. 9;

FIG. 14 is a sectional view of the lamp module taken along line 14—14 of FIG. 10.

FIG. 15 is a sectional view of the lamp module taken along line 15—15 of FIG. 9;

FIG. 16 is an exemplary embodiment of a circuit diagram of the lamp module circuit board according to the present invention;

FIG. 17 is a pictorial view of another exemplary embodiment of the present invention, showing a wall mountable charging base and four lamp modules;

FIG. 18 is a pictorial view of another exemplary embodiment of the present invention, showing a wall plug mountable charging base and single lamp modules;

FIG. 19 is a pictorial view of another exemplary embodiment of the present invention, showing a carrier/charging base and eight lamp modules;

FIG. 20 is a pictorial view showing one module-to-carrier/charging base interface;

FIGS. 21 and 22 are block diagrams respectively of exemplary carrier/charging base and lamp module circuitry.

DETAILED DESCRIPTION OF THE PREFERRED EMBODIMENTS

Referring now to FIG. 1, reference numeral 10 generally refers to the rechargeable lamp system of the present invention. Lamp system 10 comprises a charging stand 12 and a plurality of lamp modules 110, 111, 112 and 114.

As shown in FIGS. 1 and 2, stand 12 comprises slots 16, 18, 20 and 22 which are each adapted to removably receive one of said lamp modules 110, 111, 112 and 114. Slots 16, 18, 20 and 22 each include a respective cylindrical wall 38, 40, 42, and 44 and a substantially planar floor 46, 48, 50 and 52.

A power cord 24 having an inline power switch 26 and a "wall-block" style transformer provides power to charging stand 12 via ordinary 120-volt household current. In alternate embodiments, the transformer may be dispensed with.

As will be described in greater detail herein, each of modules 110, 111, 112 and 114 is battery-powered and designed to be charged by magnetic induction when placed in a respective one of slots 16, 18, 20 and 22. Modules 110, 111, 112 and 114 are each designed to illuminate when removed from slots 16, 18, 20 and 22, or when AC power is cut off to charging stand 12.

The number of lamp modules (and a corresponding slot for each module) shown in the preferred embodiment is intended to be merely exemplary. It should be understood that the lamp system 10 of the present invention may be constructed with any number of modules.

Referring now to FIGS. 3-4, stand 12 also includes an upper portion 30 and a lower portion 32. In an exemplary embodiment, upper portion 30 is ceramic. However, upper portion 30 may be made from other suitable materials, such

as wood or plastic. In the interest of economy, lower portion 32 in the exemplary embodiment is formed of injection-molded plastic, but may as well be made of other suitable materials, such as steel or other metal or other material. In the exemplary embodiment, upper portion 30 and lower portion 32 snap together. However, any suitable means, such as bonding, screws, etc. could be used to secure upper portion 30 and lower portion 32.

As shown in FIGS. 2, 5 and 6, stand 12 further includes a circuit board 58 which is hard-wired to cord 24 and four primary induction coils (wired in parallel), one coil encircling each of walls 38, 40, 42 and 44, respectively. FIG. 5 shows a pair of primary induction coils 54 and 56 that encircle walls 44 and 42, respectively. Identical primary coils (not shown) encircle walls 38 and 40.

FIG. 7 shows the circuit formed by transformer 28, inline power switch 26, and primary induction coil 54. As shown in FIG. 7, transformer 28 converts 120 volts AC to 12 volts AC. The three other primary induction coils, not shown, are preferably wired in parallel with primary induction coil 54. In other embodiments, the transformer component can be replaced by the inductor coils (on the platter and luminaries), whose turn-ratios are selected to provide a stepped-down voltage to the lamps. As will be appreciated by those of skill in the art, an oscillator providing frequencies higher than line frequency may be employed to improve efficiency (inductor size and attendant cost).

Modules 110, 111 and 112 are identical to module 114. Thus, it will only be necessary to describe module 114 in detail.

As shown in FIGS. 8-16, module 114 comprises a diffuser 116, a light bulb 118, a battery pack 120, a circuit board 122, a secondary induction coil 124 and a base 126.

Diffuser 116 in the exemplary embodiment is formed of blow-molded plastic (or glass) having a frosted outer surface 142. It could also be injection-molded plastic with a frosted, translucent finish. In the exemplary embodiment, diffuser 116 is slender and elongated in shape and includes a mid-section 146 that tapers upwardly to a tip 144 and tapers slightly to a tail 148. This shape is chosen to provide optimal light color and transmission, as well as even diffusion of light from bulb 118. Obviously, numerous alternative shapes for diffuser 116 are possible. However, the internal volume created by diffuser 116 must be sufficient to envelop bulb 118, battery pack 120 and circuit board 122. In addition, because of the heat generated by bulb 118, it is desirable to provide air space between bulb 118 and diffuser 116 to prevent diffuser 118 from melting or deforming.

Base 126 comprises a lower portion 128 that provides stable support for module 114 when placed on a level surface or within slot 16. Neck 130 is adapted to removably receive diffuser 116 (to enable access to bulb 118 and battery pack 120). Neck 130 includes tabs 134, 136, 138 and 140 and a lip 135 that cooperate to secure tail 148 of module 114 to neck 130 (see FIGS. 8, 13 and 14).

Battery pack 120 in the exemplary embodiment comprises three "AA" Nickel-Cadmium (Ni-Cad) cells wrapped in PVC shrink-wrap and having a total output of 3.6 Vdc and 500-800 mA. Of course, other types and sizes of rechargeable cells, such as Nickel-Metal-Hydride or Lithium cells, could be substituted for the Ni-Cad cells. Such cells would provide more power, and charge more quickly than Ni-Cads, but are substantially more expensive.

The power requirements for bulb 118 are, of course, chosen to match the power output of battery pack 120. In the exemplary embodiment, bulb 118 is a conventional minia-

ture incandescent bulb, such as Chicago Miniature Lamp, Inc. part #CM1738, having an output of 1 candela and having design power requirements of 2.80V and 60 mA and an expected life of 6,000 hours. Of course, other lamps and types of light sources, such as a light-emitting diode (L.E.D.) may be substituted for bulb 118. The incandescent bulb shown is preferred because of its balance of cost, heat generation, power consumption, expected service life and brightness characteristics.

As shown in FIGS. 13 and 14, bulb 118 and battery pack 120 are preferably hard-wired to circuit board 122. As shown in FIG. 16, circuit board 122 comprises four primary circuits that control the charging of battery pack 120 and the lighting of bulb 118.

A charging circuit 150 regulates the voltage and current flowing to battery pack 120 from secondary induction coil 124 to prevent damage to battery pack 120. A latch circuit 154 cuts off current to bulb 118 when the voltage output of battery pack 120 drops below 3.1 volts, thus preventing damage to battery pack 120 which could be caused by fully draining battery pack 120. A charge-sensing switch 156 works in cooperation with latch circuit 154 to turn off current to bulb 118 when current is detected in charging circuit 150. A constant current source circuit 152 provides a constant flow of current (65 mA in the exemplary embodiment) to bulb 118. This enables bulb 118 to shine at a constant brightness despite fluctuations in the output current from battery pack 120. In alternate embodiments, a constant voltage source could be employed.

As described above, battery pack 120 is charged by magnetic induction. The magnetic field created by primary induction coil 54 (when current is applied) induces a current in secondary induction coil 124 when secondary induction coil 124 is concentrically located relative to primary induction coil 54. In the present invention, this occurs when module 114 is placed within slot 16 (see FIG. 1).

It is preferable to ship battery pack 120 fully charged, as this will increase the shelf life of the Ni-Cad cells. However, shipping battery pack 120 fully charged requires the inclusion of means for electrically isolating battery pack 120 from lamp 118 between the time battery pack 120 is charged and when module 114 is first used by an end consumer. Such means could comprise a Mylar tab (not shown) inserted between two electrical contacts after the initial charging which would be removed by the consumer before first use. Alternatively, such means could comprise a fusible link (not shown). The fusible link would be adapted to close current regulating circuit 152 when current is sensed in charging circuit 150 (i.e., the first time the consumer plugs in charging stand 12).

Operation of lamp system 10 is elegantly straightforward. As described above, bulb 118 is designed to illuminate when no current is sensed in charging circuit 150. Thus, bulb 118 will automatically turn on when module 114 is removed from slot 16. Charging stand 12 and module 114 can also function as a table lamp by leaving module 114 in slot 16 and switching off inline power switch 26. Module 114 also functions as an emergency light—automatically turning on during a power failure.

Referring now to FIG. 17, reference numeral 200 generally refers to another exemplary embodiment of the rechargeable lamp system of the present invention. Lamp system 200 comprises a wall mountable charging base generally designated 202 and four lamp modules generally designated 204. The number of lamp modules shown in the preferred embodiment is intended to be merely exemplary. It

should be understood that the lamp system 200 of the present invention may be constructed with any number of modules.

As shown, the wall mountable charging base 202 comprises projections 206 spaced laterally apart a distance larger than the width of each lamp module 204, and each lamp module 204 comprises an opening thereinthrough generally designated 208 adjacent to its top surface. The projections 206 cooperate with the openings 208 to removably support the lamp modules 204 on the wall mountable charging base 202. Projections 206 and openings 208 are each of generally cylindrical geometry, although projections and openings of another geometry or other removable supporting means may be employed without departing from the inventive concepts.

Each projection has a free end, and a diffuser 210 is removably or fixedly mounted to the free end over an LED and ambient light sensor mounted thereon not shown, that switches the LED “on” in response to a condition of ambient darkness. Each lamp module 204 has a flat base 212 and a front face diffuser 214 that extends from top to bottom and surrounds the opening 208. The flat base 212 enables to place each lamp module 204 on a shelf or table and the opening 208 allows it to be carried about or hung on a hook to provide illumination in a wide variety of situations.

A power cord 216 having an inline power switch, not shown, provides power to wall mountable charging base 202 via ordinary 120-volt household current. The base 202 may be wall mounted over or spaced in relation to the AC wall outlet by any suitable mounting means, and a recess and/or power cord wrap or other means may be employed to stow any excess cord within the wall mountable charging base 202. In alternate embodiments, the power switch may be dispensed with.

As in the embodiment described above in connection with the description of the FIGS. 1–16, each lamp module 204 is designed to be charged by magnetic induction. Inductive magnetic coupling is provided by primary and secondary coils, not shown, carried on the projections 206 of the charging base and about the openings 208 of the lamp modules 204 when supported by a respective one of the projections 206. Other coupling means such as mating electrical contacts or other means could be employed without departing from the inventive concepts,

As in the embodiment described above in connection with the description of the FIGS. 1–16, modules 204 are each designed to illuminate when removed from projections 206, or when AC power is cut off to wall mountable charging base 202. The wall mountable recharging base includes a first charge circuit responsive to supplied AC power to provide a charge signal and each lamp module includes a light emitting element connected to a rechargeable battery pack via a second circuit operative in one mode to charge the rechargeable battery pack in response to the charge signal when each lamp module is supported by the wall mountable charging base and operative in another mode to activate the light emitting element in response to the absence of the charge signal, whereby, each lamp module lights if removed from the wall mountable recharging base and lights if no AC power is supplied to the wall mountable recharging base when supported thereon.

A switch, not shown, may be provided to independently turn each lamp module 204 on/off to conserve charge or to use the light as needed.

Referring now to FIG. 18, reference numeral 230 generally refers to another exemplary embodiment of the rechargeable lamp system of the present invention. Lamp system 230 comprises a wall plug mountable charging base

generally designated **232** and a single lamp module generally designated **234**. The embodiment **230** is generally the same as the embodiment **200** described above in connection with the description of FIG. **17**, except the wall plug mountable charging base **232** includes extending plug members **236** adapted to plug the base directly into a standard AC wall outlet.

Referring now to FIG. **19**, reference numeral **250** generally refers to another exemplary embodiment of the rechargeable lamp system of the present invention. Lamp system **250** comprises a carrier/charging base generally designated **252** and ten lamp modules generally designated **254**. A cover **256**, preferably translucent, is removably mounted by any suitable means to the carrier/charging base **252** and a handle member **258**, preferably of aluminum but which could be of other metal or material, is attached by any suitable means to be carrier/charging base **252**. The cover member **256** protects the lamp modules during charging, storage and transit, and the handle member **258** provides for ease of transport. The number of lamp modules shown in the preferred embodiment is intended to be merely exemplary. It should be understood that the lamp system **250** of the present invention may be constructed with any number of modules.

Referring now to FIG. **20**, reference numeral **270** generally shows a pictorial view of one module-to-carrier/charging base interface. Unlike inductive coupling employed for the hereinabove described embodiments, contacts **272** on carrier/charging base **252** cooperate with contacts **274** to provide the charge signal to each lamp module **254** when supported on the carrier/charging base **252**. Spring-loaded arms **276** are provided to hold each lamp module **254** when seated in receptacles generally designated **278** provided therefore on the carrier/charging base **252**. And on/off membrane switch **280** (or other suitable means) is provided on each lamp module **254** by which they may be independently turned on/off. A charging status LED **282** for each module is provided on the carrier/charging base **252** that lights when the associated lamp module **254** is fully charged. Seat sensor contacts **284**, **286** provides a seat signal used by each lamp module in a manner to be described to inhibit lighting of each lamp module when supported on the carrier/charging base if no AC power is supplied. The seat signal is preferably at ground potential, although any suitable sensor contact or other means providing any signal representative of a lamp module being in supported condition could be employed without departing from the inventive concepts

Referring now to FIG. **21**, reference numeral **270** generally shows a block diagram of the carrier/charging base circuitry. As shown, an AC/DC converter **272** responds to standard AC power to provide a charge signal output signal and the seat sensor **274** provides a seat signal at ground potential. The AC/DC converter **272** preferably includes a timer to turn off the charge signal after a predetermined time determined to provide a full charge for each rechargeable battery pack.

Referring now to FIG. **22**, reference numeral **300** generally shows a block diagram of the lamp module circuitry. A charging circuit **302** regulates the voltage and current flowing to battery pack **304** (of each module) to prevent damage to battery pack **304**. A latch circuit **306** cuts off current to each lamp when the voltage output of battery pack **304** drops below a predetermined value, thus preventing damage to battery pack **304** which could be caused by fully draining battery pack **304**. Latch circuit **306** works in cooperation with a charge-sensing switch **308** to turn off current to each lamp when current is detected in charging circuit **302** or when the seat signal is detected. A constant current source circuit **310**

provides a constant flow of current to each lamp. This enables the lamps to shine at a constant brightness despite fluctuations in the output current from battery pack **304**. In alternate embodiments, a constant voltage source could be employed.

The present invention in its broader aspects is not limited to the described embodiments, and departures may be made therefrom without departing from the principles of the invention and without sacrificing its primary advantages. Obviously, numerous modifications may be made to the present invention. Thus, the invention may be practiced otherwise than as specifically described herein. One feature of one embodiment may be employed in another disclosed embodiment. The power cord may be made removable to base placement without cord limitations. Other modifications will be readily apparent to one of skill in the art without departing from the scope of the present invention.

What is claimed is:

[1. An autoilluminating rechargeable lamp system, comprising:

a wall mountable recharging base adapted to removably support a set of luminaries including a first circuit coupled to each luminary of said set of luminaries supported thereby operative in response to supplied AC power to provide a charge signal to each luminary of said set of luminaries; and

a set of luminaries each having a light emitting element connected to a rechargeable battery pack via a second circuit operative in one mode to charge said rechargeable battery pack in response to said charge signal when each said luminary of said set of luminaries is supported by said wall mountable recharging base and operative in another mode to activate said light emitting element in response to the absence of said charge signal, whereby, each said luminary of said set of luminaries lights if removed from said wall mountable recharging base and is turned "off" if received on said wall mountable recharging base.]

[2. The autoilluminating rechargeable lamp system of claim **1**, wherein said first circuit includes a manually actuated switch, and wherein each said luminary of said set of luminaries lights if no AC power is supplied in response to turning off said manually actuated switch.]

[3. The autoilluminating rechargeable lamp system of claim **1**, wherein each said luminary of said set of luminaries lights if no AC power is supplied in response to an AC power service failure.]

[4. The autoilluminating rechargeable lamp system of claim **1**, wherein the set of luminaries includes one or more luminaries.]

[5. The autoilluminating rechargeable lamp system of claim **4**, wherein each luminary of said set of luminaries is inductively coupled to said charge signal provided by said first circuit of said recharging platter.]

[6. The autoilluminating rechargeable lamp system of claim **1**, wherein, each luminary of said set of luminaries is self-standing and includes a front face diffuser.]

[7. The autoilluminating rechargeable lamp system of claim **1**, wherein said wall mountable charging base has at least one projection adapted to support a luminary and wherein each luminary of said set of luminaries has an opening adapted to be supported by each said at least one projection.]

[8. The autoilluminating rechargeable lamp system of claim **7**, wherein each said projections and openings is generally cylindrically shaped.]

[9. The autoilluminating rechargeable lamp system of claim **8**, wherein each said projection has a free end, and further including a diffuser mounted to said free end.]

[10. The autoilluminating rechargeable lamp system of claim 1, wherein said wall mountable charging base is a wall plug mountable charging base.]

[11. An autoilluminating rechargeable lamp system, comprising:

a charging base removably supporting a set of luminaries including a charge circuit providing a charge signal to each luminary of said set of luminaries supported by said base;

a set of luminaries each including a lamp and a rechargeable battery pack connected to said lamp; and

autoilluminating means coupled to each luminary of said set of luminaries and responsive to said charge signal for lighting said lamp of each luminary in response to non-detection of said charge signal, and for turning said lamp of each luminary "off" in response to detection of said charge signal, whereby, each said luminary of said set of luminaries lights if removed from said base and is turned "off" if supported thereby.]

[12. The autoilluminating rechargeable lamp system of claim 11, wherein said set includes one or more luminaries.]

[13. The autoilluminating rechargeable lamp system of claim 11, wherein said charging base is a wall mountable charging base.]

[14. The autoilluminating rechargeable lamp system of claim 13, wherein said wall mountable charging base is a wall plug mountable charging base.]

15. An autoilluminating rechargeable lamp system, comprising:

a charging subassembly adapted to removably support a set of luminaries including a first circuit coupled to each luminary of said set of luminaries when supported thereon operative in response to supplied [AC] power to provide a charge signal to each luminary of said set of luminaries when supported thereon;

a sensor to provide a seat signal representative that each luminary of said set of luminaries is supported on said charging [base] subassembly; and

a set of luminaries *including one or more luminaries*, each luminary having a light emitting element connected to a rechargeable battery pack via a second circuit operative in one mode to charge said rechargeable battery pack in response to said charge signal when each luminary of said set of luminaries is supported thereon and operative in another mode to activate said light emitting element in response to the absence of said seat signal, whereby, each said luminary lights if removed from said charging subassembly, does not light if no [AC] power is supplied to said charging subassembly when supported thereon, and does not light if there is no charge signal when supported thereon.

[16. The autoilluminating rechargeable lamp system of claim 15, wherein said set includes one or more luminaries.]

17. The autoilluminating rechargeable lamp system of claim 15, wherein said charging subassembly is a charging base, *and the autoilluminating rechargeable lamp system further includes a cover removably mounted to said charging base.*

[18. The autoilluminating rechargeable lamp system of claim 17, further including a cover removably mounted to said charging base.]

[19. The autoilluminating rechargeable lamp system of claim 17, further including a handle mounted to said charging base.]

20. The autoilluminating rechargeable lamp system of claim 15, further including a switch mounted to at least one said luminary of said set of luminaries to independently turn it on/off.

[21. An autoilluminating lamp system, comprising:

a base member adapted to removably support at least one rechargeable lamp member receivable on and removable from said base member;

at least one lamp member each including a light having an "on" and an "off" state powered by a power source, each said at least one lamp member is adapted to be received on and removed from said base member; and

an autoilluminating circuit coupled to each said at least one lamp member operative in one mode in response to receipt of each said at least one lamp member on said base member adapted to removably support at least one lamp member each adapted to be received on and removed from said base member to place said light of each said at least one lamp member received on said base member in its "off" state, and operative in another mode in response to removal of each said at least one lamp member from said base member adapted to removably support at least one lamp member each adapted to be received on and removed from said base member to place said light of each said at least one lamp member removed from said base member in its "on" state; whereby, each said at least one lamp member lights if removed from said base member and de-lights if received on said base member.]

[22. The autoilluminating lamp system of claim 21, wherein each said at least one lamp member is a rechargeable lamp member; and wherein said power source of each said at least one rechargeable lamp member is a rechargeable battery.]

[23. The autoilluminating lamp system of claim 22, further including a charge circuit adapted to provide a charge signal in response to supplied AC power; and wherein said autoilluminating circuit operative in response to receipt of each said at least one lamp member on said base member is further operative in said one mode to apply said charge signal to said rechargeable battery of each said at least one rechargeable lamp member received on said base member.]

24. *An autoilluminating rechargeable lamp system comprising:*

a set of luminaries each having a light emitting element connected to a rechargeable battery pack, the set of luminaries including one or more luminaries;

a recharging support, each of the set of luminaries being engagable with and supportable by the recharging support, the recharging support providing a charge to each of the set of luminaries engaged therewith in response to power supplied to the recharging support;

each of the set of luminaries including an autoilluminating circuit electrically responsive to the charge of the recharging support for turning the luminary on or off.

25. *The autoilluminating rechargeable lamp system of claim 24 wherein each luminary supported on the recharging support is inductively coupled by the presence of the power from the recharging support, the inductive coupling providing the charge for charging the battery pack, and the auto-illuminating circuit responsive to the inductive coupling for turning the luminary off and responsive to an absence of the inductive coupling to turn the luminary on.*

26. *A lamp system comprising:*

a set of luminaries each having a light emitting element and a battery pack connected thereto, the set of luminaries including one or more luminaries;

a support for engaging and supporting the luminaries and providing an electrical signal to each of the luminaries

11

engaged therewith, wherein the luminaries are electrically responsive to said electric signal to determine an "on" or "off" state for the light emitting element.

27. The lamp system of 26 wherein the support is wall mountable.

28. The lamp system of 26 wherein the support and each of the luminaries include respective electric contacts engagable when the luminary is engaged with the support, the support providing the electrical signal to each of said luminaries via the electric contacts.

29. The lamp system of 26 wherein the support provides the electrical signal to each of the luminaries via one or more induction circuits, the signal being provided when the luminary is engaged with the support.

30. The lamp system of 26 wherein the battery pack is rechargeable, and the support provides power to the battery pack when the luminary is engaged with the support.

31. A lamp system comprising:

a set of luminaries including one or more luminaries, each luminary having a light emitting element connected to a rechargeable battery pack;

a wall-mountable recharging support having a first portion positionable proximate to a wall and a second portion extending at least partially laterally to the first portion for supporting each of the luminaries, each of the set of luminaries being engagable with the recharging support to receive power from the recharging support for charging the battery pack thereof, the recharging support providing a charge to each of the set of luminaries engaged therewith in response to power supplied to the recharging support;

each of the set of luminaries including an auto-illuminating circuit responsive to the power from the recharging support for turning the luminary on or off.

32. The lamp system of claim 31 wherein each luminary is responsive to a presence of the power from the recharging support to turn off.

33. The lamp system of claim 31 wherein each luminary is responsive to an absence of the power from the recharging support to turn off.

34. The lamp system of claim 31 wherein each luminary includes a mechanically-responsive manually actuated switch, and, to turn the luminary on or off, the luminary responds via the electrically-responsive auto-illuminating circuit to a presence or an absence of the power from the recharging support and responds via the manually actuated switch.

35. The lamp system of claim 34 wherein the manually actuated switch has a first position opening a mechanically-activated circuit so that the luminary is off.

36. The lamp system of claim 35 wherein the manually actuated switch has a second position closing the mechanically-activated circuit, and, with the manually actu-

12

ated switch in the second position, the luminary is turned on in the absence of the power from the recharging support and is turned off in the presence of power from the recharging support.

37. The lamp system of claim 31 wherein each luminary supported on the recharging support is inductively coupled by the presence of the power from the recharging support, the inductive coupling providing power for charging the battery pack, and the auto-illuminating circuit responsive to the inductive coupling for turning the luminary off.

38. An autoilluminating lamp system comprising:

a set of luminaries including one or more luminaries, each luminary having a first circuit, a light emitting element, a rechargeable battery pack connected to the light emitting element via the first circuit, and a second circuit for receiving electrical power for charging the battery pack;

a recharging support providing electrical power to the second circuit, wherein the recharging support is adapted to be mounted on a wall for receiving electrical current, the recharging support adapted to support each of the luminaries thereon, and the luminaries being responsive to the received power from the recharging support to open or close the first circuit to turn the luminary off or on, respectively.

39. The autoilluminating lamp system of claim 38 wherein the first circuit includes a non-mechanical switch, the non-mechanical switch being opened or closed by the second circuit in response to an absence or presence of electrical power being delivered by the recharging support.

40. The autoilluminating lamp system of claim 38 wherein the recharging support includes a first portion positionable against or proximate to a wall and a second portion extending at least partially laterally to the first portion for supporting each of the luminaries.

41. The autoilluminating lamp system of claim 38 wherein each luminary supported on the recharging support is inductively coupled by the presence of the power from the recharging support, the inductive coupling providing power for charging the battery pack, and the second circuit responsive to the inductive coupling for opening the first circuit to turn the luminary off.

42. The autoilluminating lamp system of claim 38 wherein the recharging support has at least one projection adapted to support a luminary and wherein each luminary of said set of luminaries has an opening adapted to be supported by each the at least one projection.

43. The autoilluminating lamp system of claim 42 wherein each projection and each opening are generally cylindrically shaped.

44. The autoilluminating lamp system of claim 43 wherein each said luminary has a free end including a diffuser.

* * * * *