

US00RE41536E

(19) **United States**
(12) **Reissued Patent**
Hagelstein et al.

(10) **Patent Number:** **US RE41,536 E**
(45) **Date of Reissued Patent:** **Aug. 17, 2010**

(54) **INJECTION MOLDING APPARATUS HAVING AN ELONGATED NOZZLE INCORPORATING MULTIPLE NOZZLE BODIES IN TANDEM**

(75) Inventors: **Hans Hagelstein**, Bischweier (DE); **Andreas Schrom**, Forbach/Bermersbach (DE); **Denis Babin**, Georgetown, CA (US); **Gino Colonico**, Georgetown, CA (US)

(73) Assignee: **Mold-Masters (2007) Limited**, Georgetown (CA)

4,818,217 A	4/1989	Schmidt et al.
4,836,766 A	6/1989	Gellert
4,875,845 A	10/1989	Hara et al.
4,875,848 A	10/1989	Gellert
4,892,474 A	1/1990	Gellert
4,899,288 A	2/1990	Tsutsumi
4,902,218 A	2/1990	Leonard et al.
4,945,630 A	8/1990	Gellert
4,981,431 A	1/1991	Schmidt
5,028,227 A	7/1991	Gellert et al.
5,046,942 A	9/1991	Gellert
5,051,086 A	9/1991	Gellert
5,061,174 A	10/1991	Gellert
5,125,827 A	6/1992	Gellert

(21) Appl. No.: **12/351,770**

(Continued)

(22) Filed: **Jan. 9, 2009**

FOREIGN PATENT DOCUMENTS

Related U.S. Patent Documents

AU 452137 B2 3/1973

Reissue of:

(Continued)

(64) Patent No.: **7,160,100**
 Issued: **Jan. 9, 2007**
 Appl. No.: **10/751,507**
 Filed: **Jan. 6, 2004**

OTHER PUBLICATIONS

U.S. Appl. No. 60/460,417, filed Apr. 7, 2003, Olaru.*

(Continued)

(51) **Int. Cl.**
B29C 45/20 (2006.01)

Primary Examiner—Tim Heitbrink
(74) *Attorney, Agent, or Firm*—Medler Ferro PLLC

(52) **U.S. Cl.** **425/549**

(57) **ABSTRACT**

(58) **Field of Classification Search** 425/549
See application file for complete search history.

The present invention generally relates to an injection molding apparatus, comprising a manifold including a plurality of manifold channels and a plurality of nozzles. Each of the nozzles defines a nozzle channel in fluid communication with one of the manifold channels and including a plurality of nozzle bodies coupled in tandem by a removable and secure connection. The nozzle bodies include at least an upstream nozzle body and a downstream nozzle body. The upstream nozzle body has an upstream end adjacent said manifold channel, and the downstream nozzle body has a downstream end adjacent a mold plate. A removable nozzle tip is retained in a downstream end of each downstream nozzle body. The nozzles also include a plurality of heaters, wherein at least one heater is embedded into each nozzle body.

(56) **References Cited**

U.S. PATENT DOCUMENTS

3,677,682 A	7/1972	Putkowski
3,812,323 A	5/1974	Pink
3,843,295 A	10/1974	Greenberg et al.
4,230,934 A	10/1980	ter Beek et al.
4,344,750 A	8/1982	Gellert
4,370,115 A	1/1983	Miura
4,517,453 A	5/1985	Tsutsumi
4,557,685 A	12/1985	Gellert
4,576,567 A	3/1986	Gellert
4,662,837 A	5/1987	Anderson
4,678,426 A	7/1987	Stauber
4,795,338 A	1/1989	Gellert

67 Claims, 10 Drawing Sheets

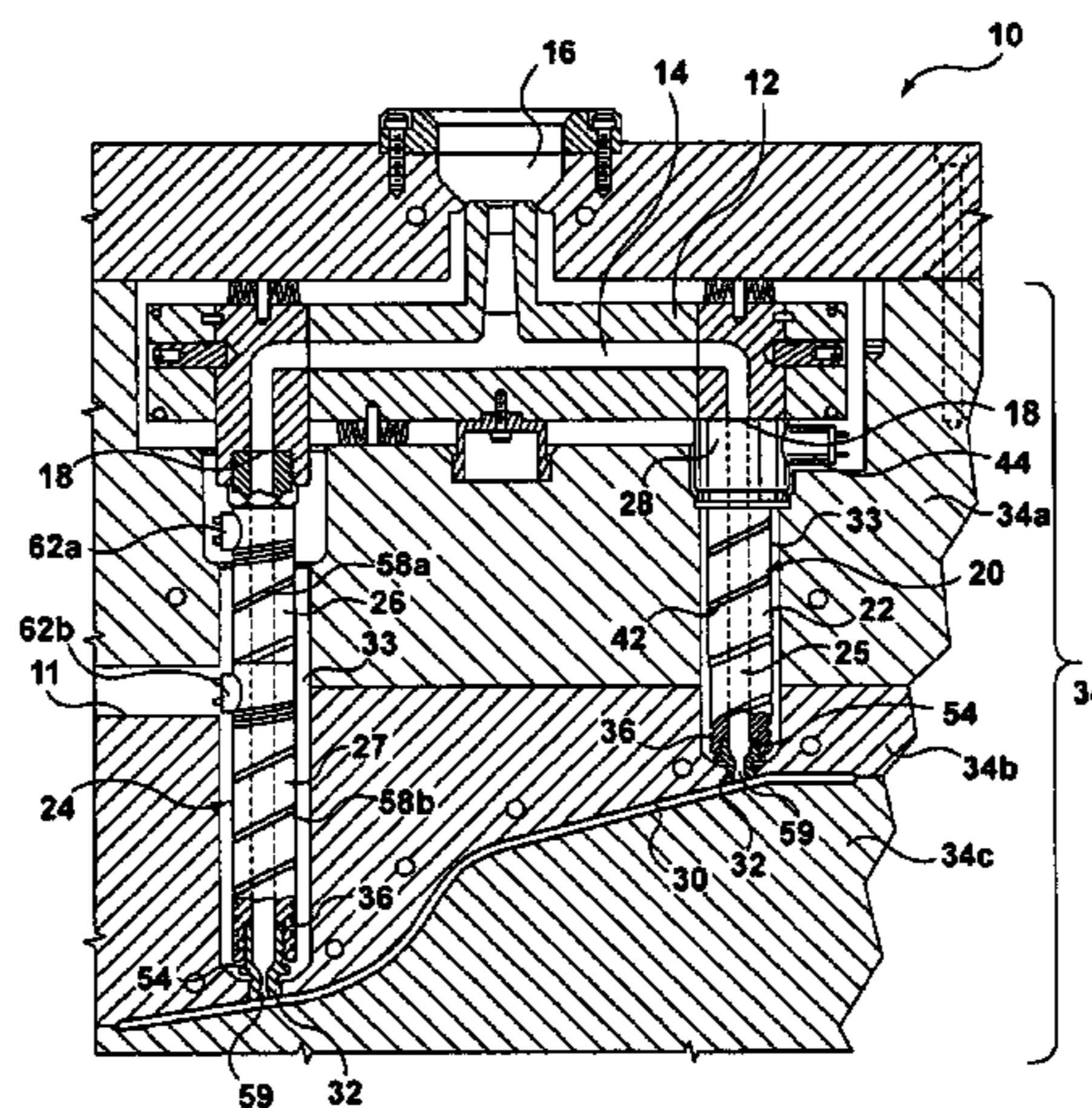

U.S. PATENT DOCUMENTS

5,135,377	A	8/1992	Gellert
5,225,211	A	7/1993	Imaida et al.
5,232,710	A	8/1993	Miyazawa et al.
5,268,184	A	12/1993	Gellert
5,299,928	A	4/1994	Gellert
5,316,468	A	5/1994	Gunther
5,320,513	A	6/1994	Schmidt
5,421,716	A	6/1995	Gellert
5,494,433	A	2/1996	Gellert
5,507,637	A	4/1996	Schad et al.
5,518,389	A	5/1996	Nonomura et al.
5,536,165	A	7/1996	Gellert
5,591,465	A	1/1997	Babin
5,609,893	A	3/1997	Eastwood
5,820,803	A	10/1998	Hashimoto
5,820,899	A	10/1998	Gellert
5,871,786	A	2/1999	Hume et al.
5,879,727	A	3/1999	Puri
5,894,025	A	4/1999	Lee et al.
5,952,016	A	9/1999	Gellert
6,095,790	A	8/2000	Gellert et al.
6,230,384	B1	5/2001	Gellert et al.
6,261,083	B1	7/2001	Stern
6,305,923	B1	10/2001	Godwin et al.
6,447,283	B1	9/2002	Gellert
6,666,675	B2	12/2003	Ihara et al.
6,712,597	B1	3/2004	Van Boekel
6,789,745	B1	9/2004	Babin et al.
6,921,257	B2	7/2005	Olaru
7,118,703	B2	10/2006	Trudeau
7,121,820	B2	10/2006	Tooman et al.
7,131,833	B2	11/2006	Babin
7,137,806	B2	11/2006	Babin et al.
7,179,081	B2	2/2007	Sicilla et al.
7,252,498	B2	8/2007	Olaru
7,306,454	B2	12/2007	Babin et al.
7,462,030	B2	12/2008	Fischer et al.
2004/0005380	A1	1/2004	Babin et al.
2004/0101589	A1	5/2004	Babin
2004/0166194	A1	8/2004	Trudeau
2004/0197437	A1	10/2004	Olaru
2005/0019444	A1	1/2005	Sicilla et al.
2005/0100625	A1	5/2005	Tooman et al.
2005/0147713	A1	7/2005	Hagelstein et al.
2005/0225000	A1	10/2005	Tabassi
2005/0226956	A1	10/2005	Fischer et al.

FOREIGN PATENT DOCUMENTS

DE	86 18 162	U1	10/1986
DE	86 20 956	U1	1/1987
DE	40 05 437		8/1991
DE	4005437	C2	5/1992
DE	43 12 153	A1	12/1994

DE	43 24 027	A1	1/1995
DE	4404894	C1	1/1995
DE	44 04 894	C1	1/1995
DE	103 33 206	A1	4/2004
EP	0 438 739	A1	7/1991
EP	0 438 739	B1	7/1991
EP	0 443 203	A2	8/1991
EP	0 443 203	A3	8/1991
EP	0 443 203	B1	8/1991
EP	0 583 601	A1	2/1994
EP	0443203	B1	8/1994
EP	0 995 574	B1	4/2000
EP	0 995 574	A1	4/2000
EP	0 835 176	B1	5/2000
EP	1 148 985	B1	10/2001
EP	1244541	B1	10/2004
EP	1466715	A1	10/2004
FR	2641227	A1	7/1990
JP	60-110416	A	6/1985
JP	63-202418	A	8/1988
JP	2-112919	A	4/1990
JP	9-123222	A	5/1997
JP	11-58448	A	3/1999
JP	2002-331552	A	11/2002
JP	2003-276057	A	10/2003
JP	2005-132026	A	5/2005
KR	10-2006-0032979	A	4/2006
WO	WO-95/05930	A1	3/1995
WO	WO-00/46008	A1	8/2000
WO	WO-01/15884	A3	3/2001
WO	WO-01/15884	A2	3/2001
WO	WO-03/080315	A1	10/2003

OTHER PUBLICATIONS

“AuBenbeheizte HeiBkanalduse, 230 V. fur schnelle Far-
bwechsel (with translation)”, *Ewikon Brochure*, Oct. 2000.
“Automotive Hotrunners”, *Mold Hot Runners Solutions, Inc.*
Product Information, Jul. 2002.
“HPS III–NV Valve Gate Systems”, *Ewikon Brochure* Jun. ,
2001.
“PSG Brochure”, Date Unknown.
Lohl, R., “Standardisiertas Schmelzeleitsystem fur Grob-
werkzeuge”, *Plastverarbeiter* 38 Jahrgang 1987.
U.S. Appl. No. 60/460,418, filed Apr. 7, 2003, Sicilia et al.
U.S. Appl. No. 60/468,973, filed May 9, 2003, Olaru.
U.S. Appl. No. 60/559,977, filed Apr. 7, 2004, Fischer et al.
U.S. Appl. No. 10,819,165, filed Apr. 7, 2004, Sicila et al.
U.S. Appl. No. 60/559,976, filed Apr. 7, 2004, Tabassi.
U.S. Appl. No. 10/819,267, Apr. 7, 2004, Olaru.
Mold Hot Runner Solutions Product Information entitled
“Automotive Hotrunners,” Mold Hot Runner Solutions, Inc.,
Jul. 2002.

* cited by examiner

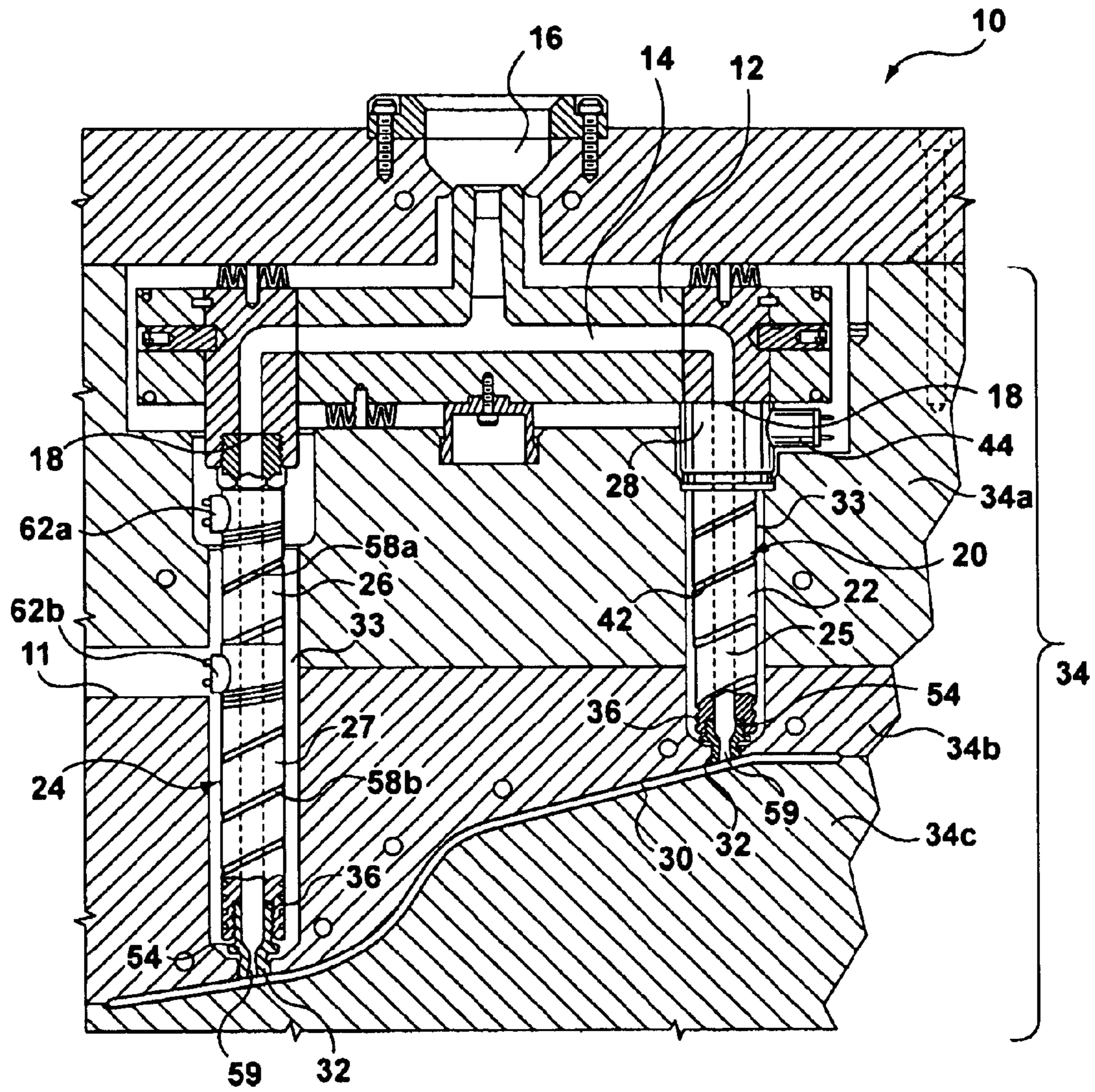

FIG. 1A

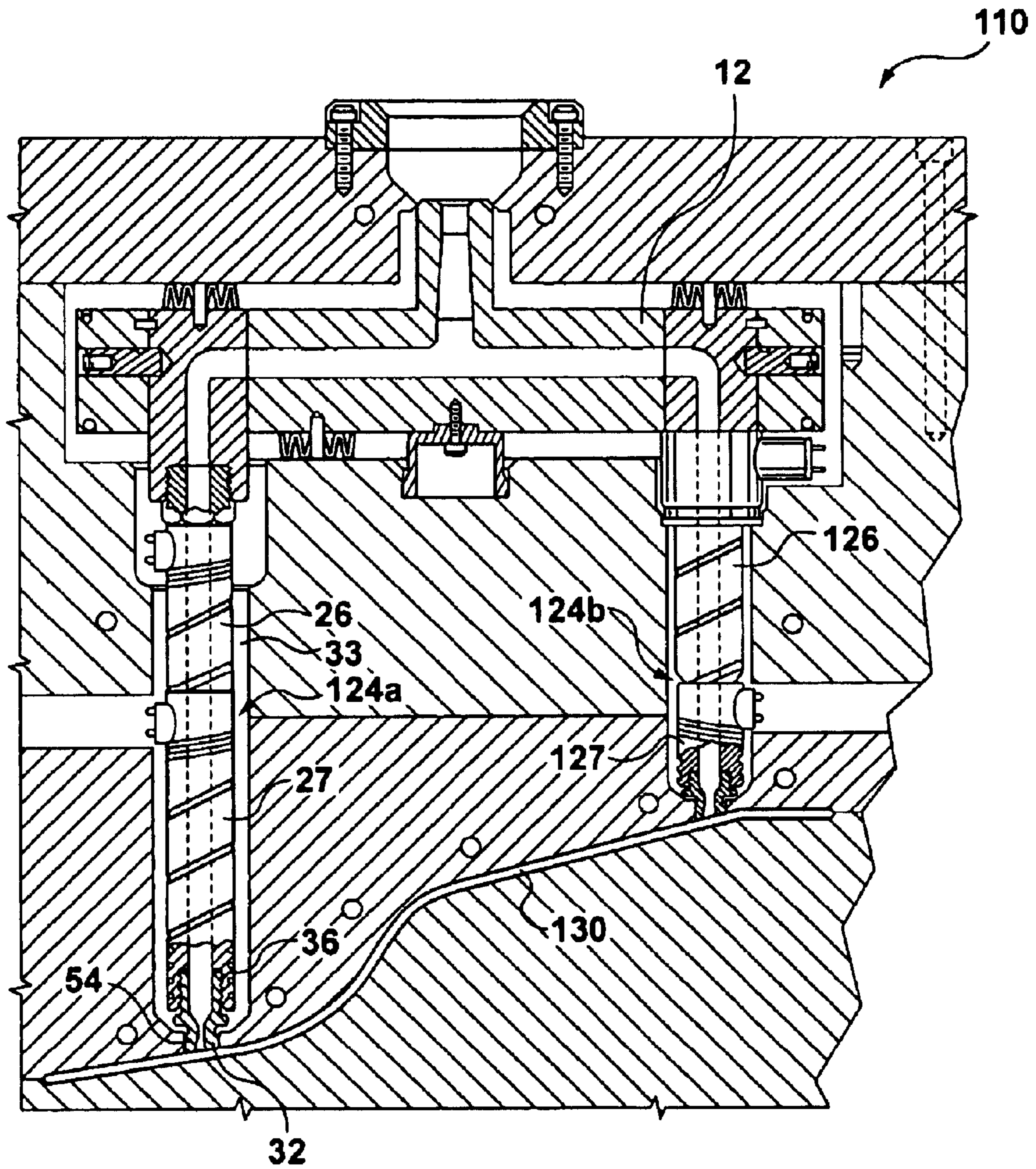
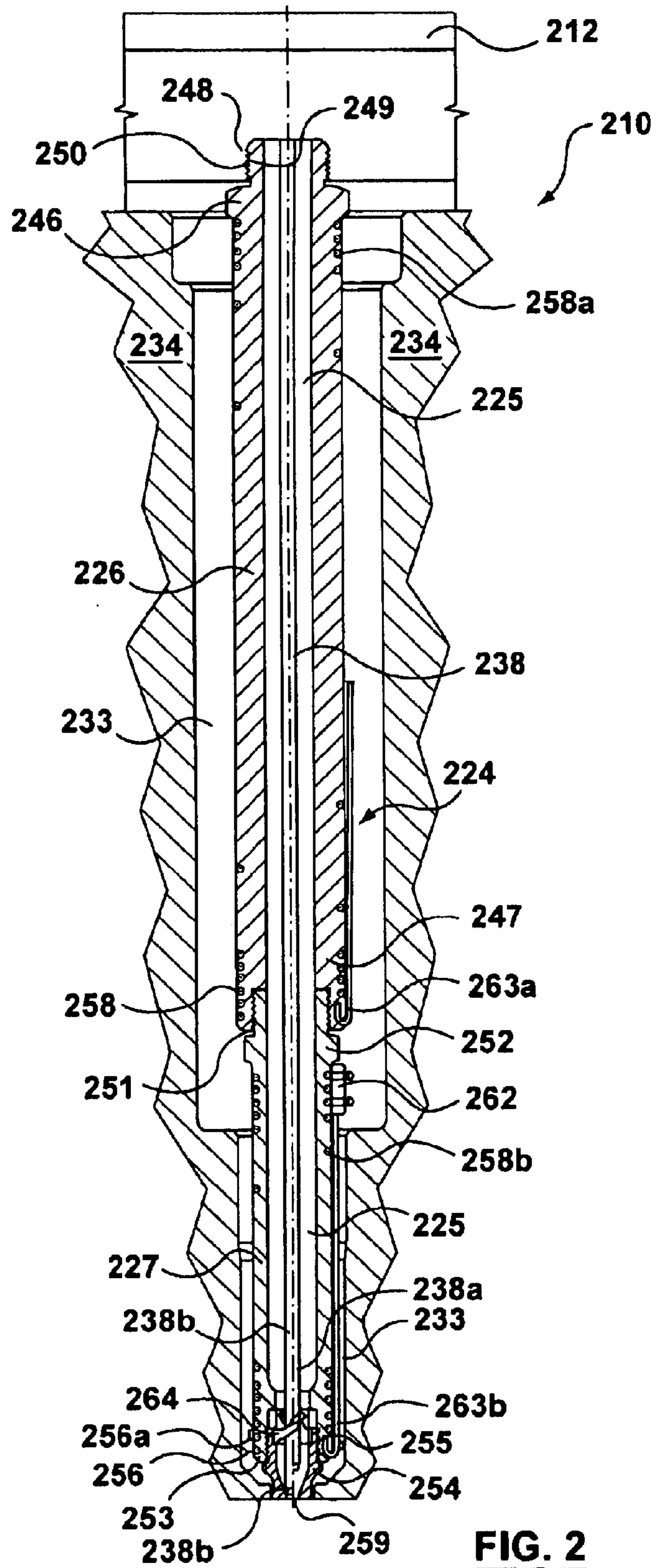

FIG. 1B



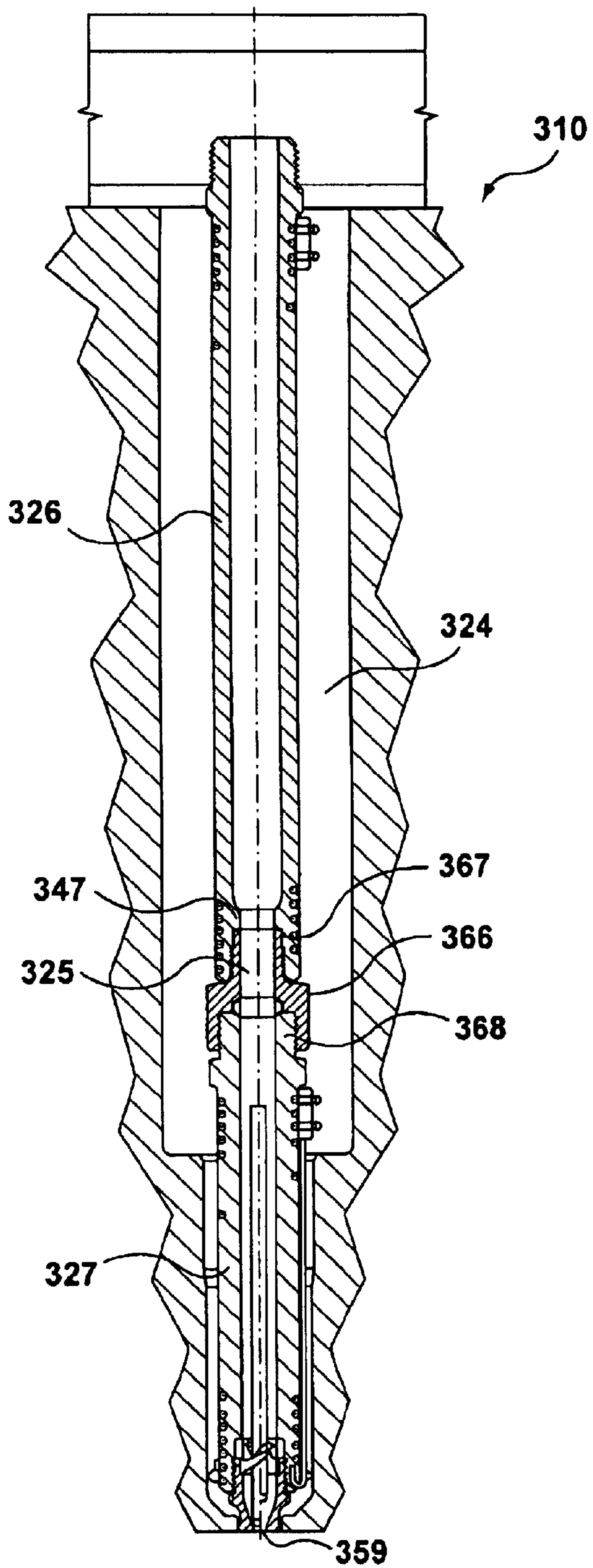

FIG. 3

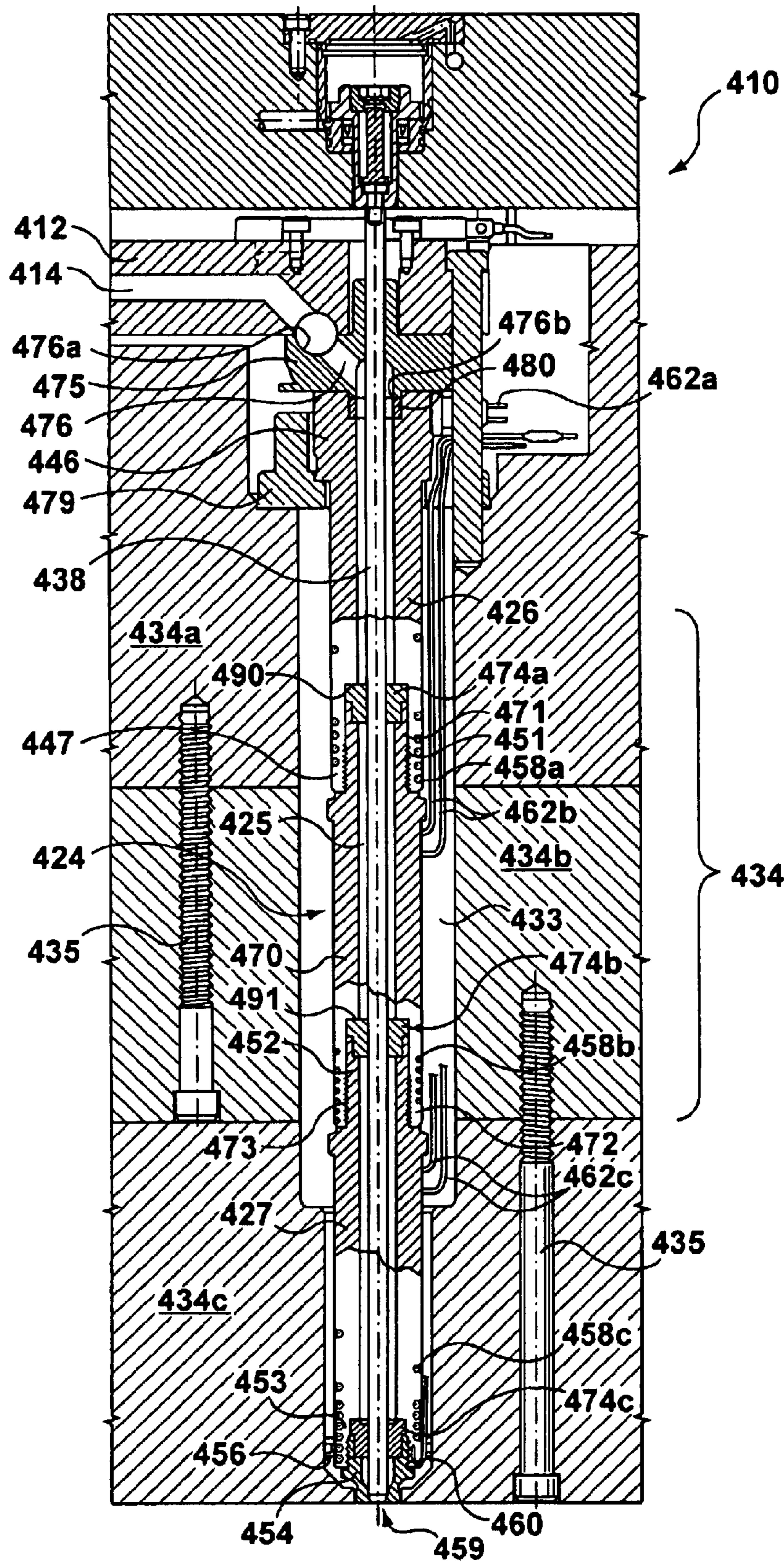

FIG. 4

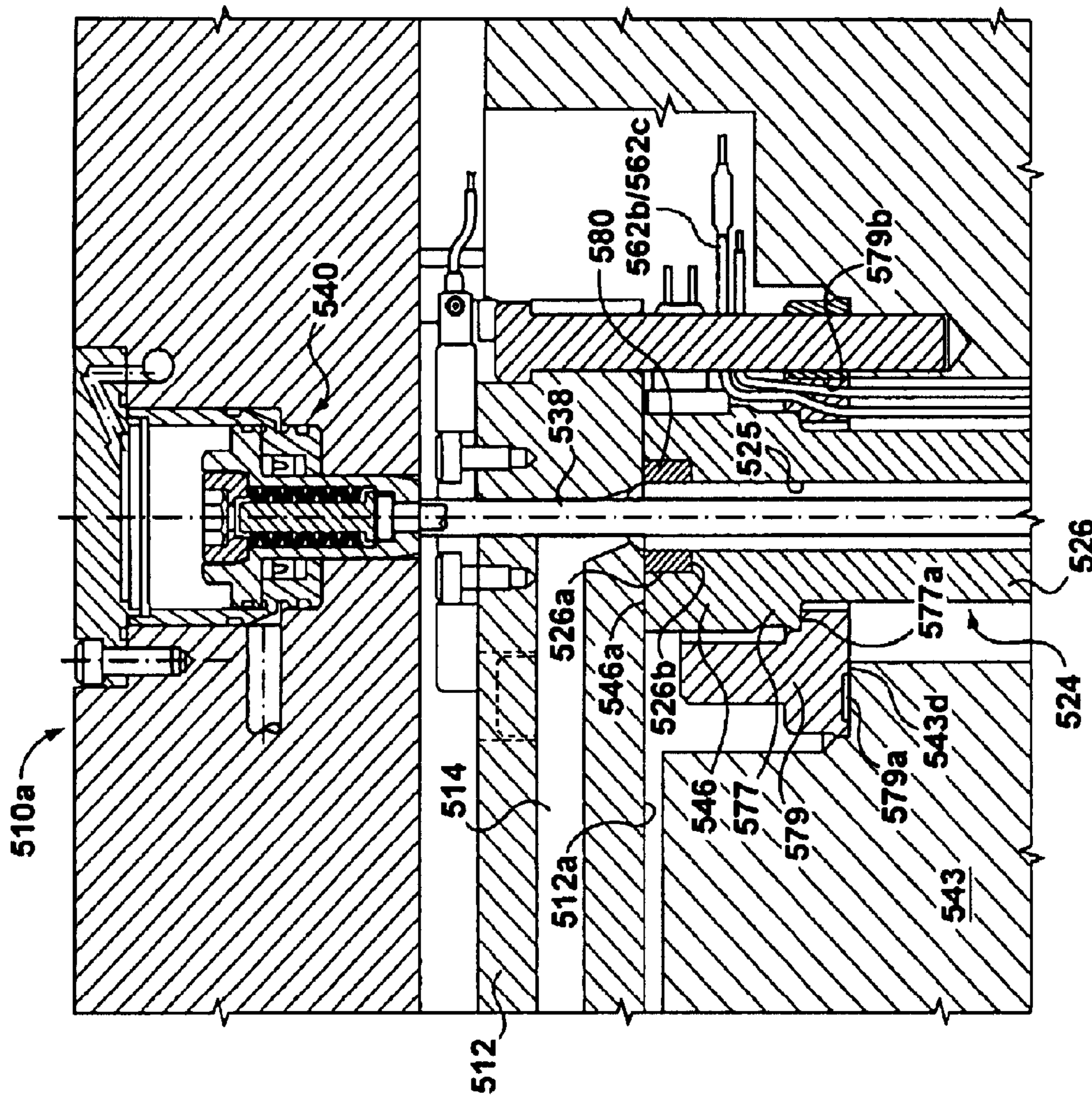

FIG. 5B

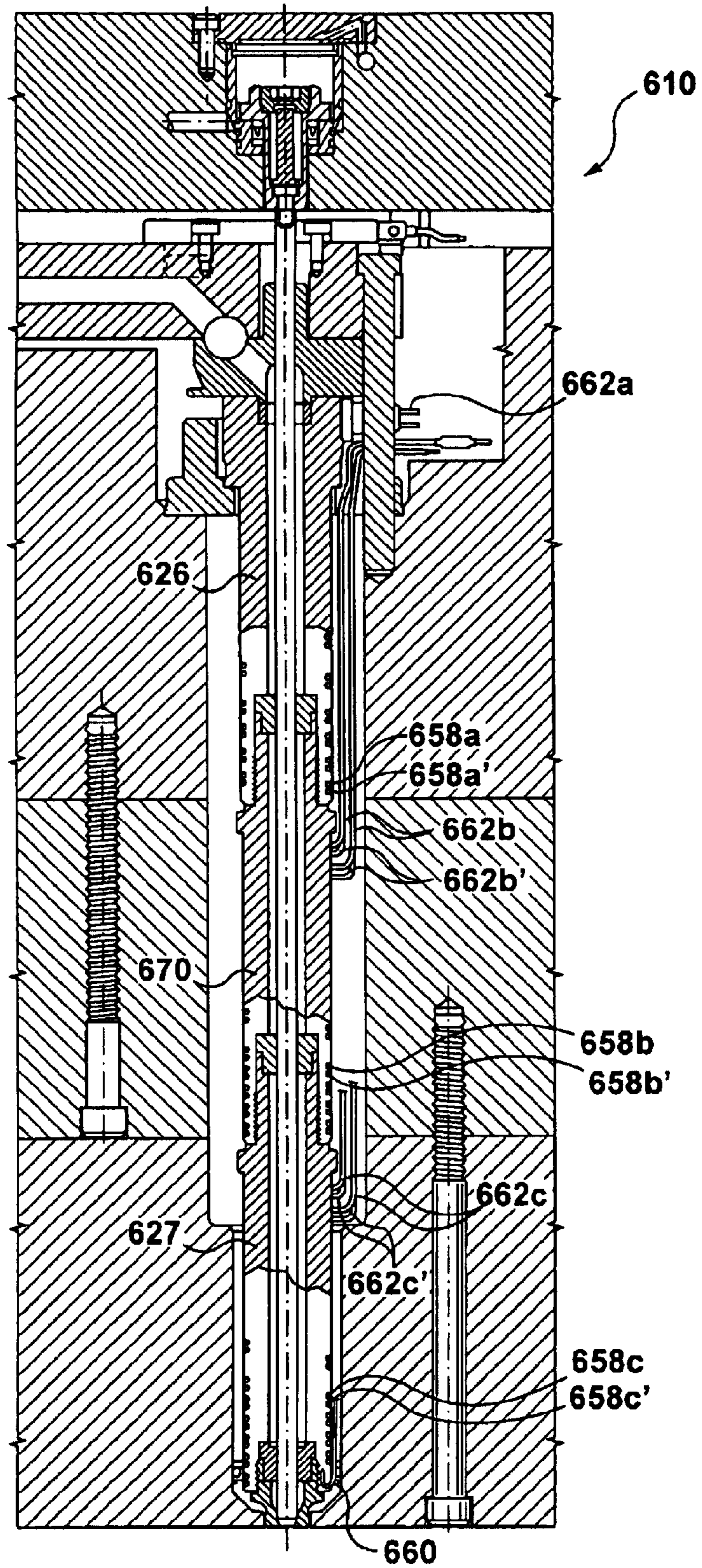

FIG. 6

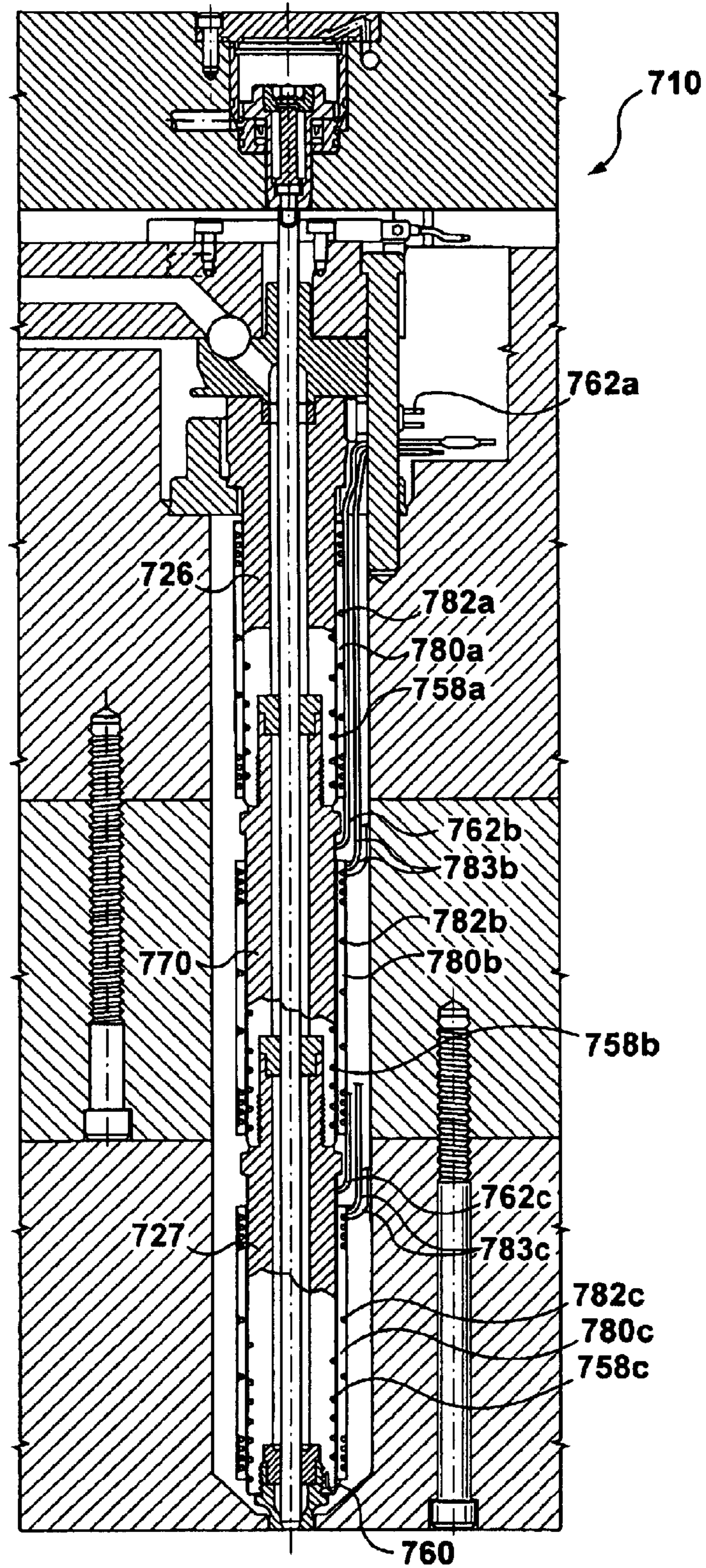
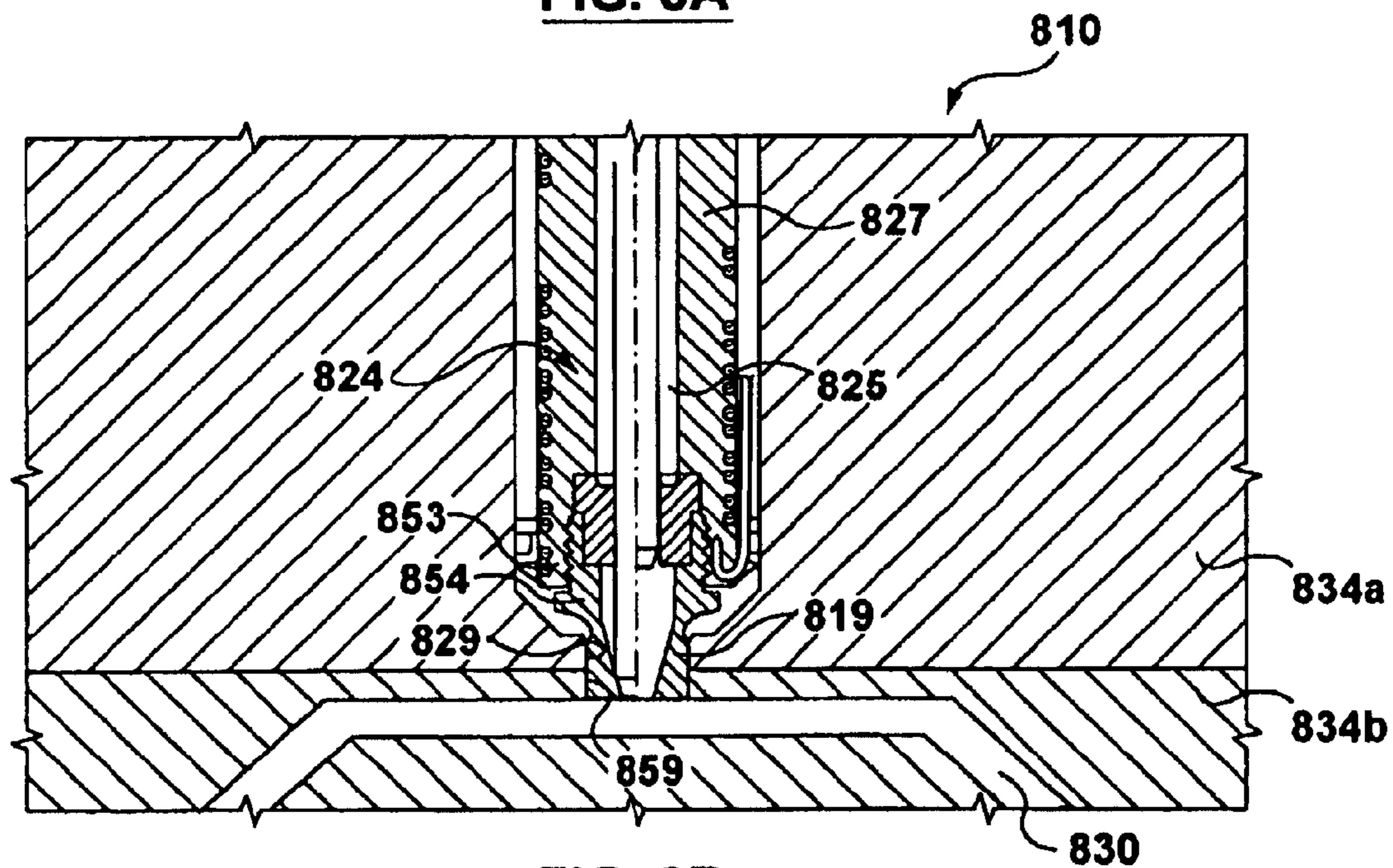
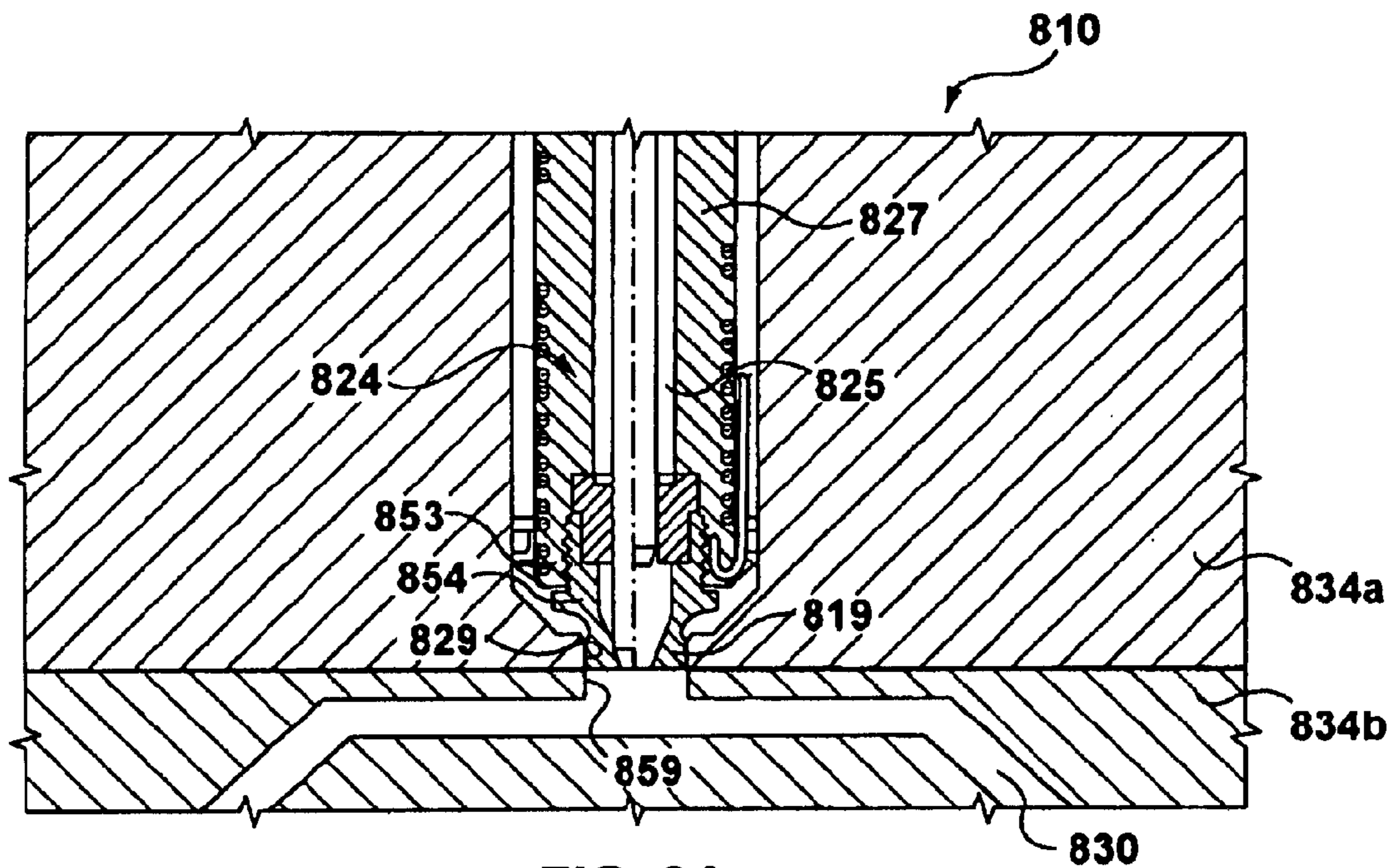

FIG. 7



**INJECTION MOLDING APPARATUS HAVING
AN ELONGATED NOZZLE INCORPORATING
MULTIPLE NOZZLE BODIES IN TANDEM**

Matter enclosed in heavy brackets [] appears in the original patent but forms no part of this reissue specification; matter printed in italics indicates the additions made by reissue.

FIELD OF THE INVENTION

This invention relates generally to an injection molding apparatus having an elongated nozzle incorporating multiple nozzle bodies arranged in tandem.

BACKGROUND OF THE INVENTION

As is well known in the art, hot runner injection molding systems include a manifold for conveying pressurized melt from an inlet to one or more manifold outlets. An injection molding apparatus may also include a nozzle having two nozzle bodies. An example of an injection molding apparatus having two nozzle bodies in tandem can be found in U.S. Pat. No. 4,818,217 to Schmidt et al., which is incorporated herein by reference in its entirety. In particular, these nozzles are used in situations where it is desirable to have a longer nozzle from a conventional nozzle, or an extended nozzle. For example, an extended nozzle may be used when the injection of the plastic and the ejection of the product are mounted on the same side of the mold. Another environment where extended nozzles may be useful is when multiple split molds are used with a single hot runner manifold. This type of apparatus is generally described in U.S. Pat. No. 3,843,295 to Greenberg et al., which is incorporated herein by reference in its entirety.

Thermal expansion can cause tandem nozzles to expand, causing a downstream nozzle to push against an adjacent mold plate. One solution to this problem is to have one nozzle telescope inside another to form a sliding interface between the two nozzles. Thus, as the nozzles thermally expand, the interface between the nozzles can adapt to account for the thermal expansion. However, such an interface between the nozzles can cause leakage, particularly when thermal expansion causes shifting between the two nozzles.

Further, melt flowing through a nozzle channel provides best results when maintained at a consistent temperature. Thus, a heater is generally provided for a nozzle along its length to control the temperature of the melt.

BRIEF SUMMARY OF THE INVENTION

The present invention is directed towards an injection molding apparatus having at least one elongated nozzle comprising at least two nozzle bodies connected in tandem. In particular, one aspect of the present invention is an injection molding apparatus comprising a hot runner manifold including at least two manifold channels and at least two nozzles. Each nozzle defines a nozzle channel in fluid communication with one of the manifold channels. At least one of the nozzles includes at least two nozzle bodies removably fastened in tandem, including at least an upstream nozzle body, having an upstream end adjacent said manifold channel, and a downstream nozzle body, having a downstream end adjacent a mold plate. A separate and removable nozzle tip is retained in a downstream end of the downstream nozzle body. The advantage of having a nozzle tip in a downstream end of a downstream nozzle body is that pressure

created by thermal expansion affects the nozzle tip, which is more easily replaced than a downstream nozzle body. Further, the nozzle tip may provide relief from this pressure by having an extended portion which is slidably positioned adjacent the mold plate, such that the nozzle tip may slide with respect to the mold plate upon thermal expansion. The pressure may alternatively be relieved by having the upstream end of the upstream nozzle slidably positioned adjacent the manifold.

In another aspect of the present invention, each of the nozzle bodies includes at least one heater attached thereto. However, each nozzle tip does not have a separate heater connected directly thereto. The nozzle tip receives adequate heat from the heater attached to the adjacent nozzle body to maintain the temperature of the melt stream as it leaves the nozzle. A nozzle tip without a heater has the advantage of being easily replaced due to wear caused by thermal expansion, without the need for disconnecting electrical connections to a heater specifically for the nozzle tip.

In yet another aspect of the present invention, each of the nozzle bodies of a nozzle of an injection molding apparatus includes at least a first heater and a second heater, wherein at least the first heater is embedded into the nozzle body. Further, the second heater may either be embedded into the nozzle or embedded in a heating band coupled to the nozzle. Additional heaters provide for more even temperature control along a nozzle.

Further features and advantages of the invention, as well as the structure and operation of various embodiments of the invention, are described in detail below with reference to the accompanying drawings. It is noted that the invention is not limited to the specific embodiments described herein. Such embodiments are presented herein for illustrative purposes only. Additional embodiments will be apparent to persons skilled in the relevant art(s) based on the teachings contained herein.

BRIEF DESCRIPTION OF THE FIGURES

The accompanying drawings, which are incorporated herein and form a part of the specification, illustrate the present invention and, together with the description, further serve to explain the principles of the invention and to enable a person skilled in the pertinent art to make and use the invention.

FIG. 1A illustrates an injection molding apparatus, with nozzles of various lengths having either a single or multiple nozzle bodies.

FIG. 1B illustrates an alternate embodiment of an injection molding apparatus, with nozzles of various lengths having various sized multiple nozzle bodies.

FIG. 2 illustrates a schematic cross-section of a portion of an injection molding apparatus of the present invention including a nozzle having tandem nozzle bodies.

FIG. 3 illustrates a schematic cross-section of an alternate embodiment of an injection molding apparatus of the present invention including an alternate connection between tandem nozzle bodies.

FIG. 4 illustrates a schematic cross-section of an alternate embodiment of an injection molding apparatus of the present invention including three nozzle bodies in tandem.

FIG. 5A illustrates an enlarged schematic cross-section of an alternate embodiment of an injection molding apparatus of the present invention including a nozzle positioned adjacent a manifold.

FIG. 5B illustrates an enlarged schematic cross-section of an alternate embodiment of an injection molding apparatus

3

of the present invention including a valve gated nozzle positioned adjacent a manifold.

FIG. 6 illustrates a schematic cross-section of an alternate embodiment of an injection molding apparatus of the present invention including double heaters.

FIG. 7 illustrates a schematic cross-section of an alternate embodiment of an injection molding apparatus of the present invention including heating bands.

FIG. 8A illustrates an enlarged schematic cross-section of an alternate embodiment of an injection molding apparatus of the present invention including a nozzle tip positioned adjacent a mold gate at a cold non-operational temperature.

FIG. 8B illustrates an enlarged schematic cross-section of an alternate embodiment of an injection molding apparatus of the present invention including a nozzle tip positioned adjacent a mold gate when heated to an operational temperature.

The present invention will be described with reference to the accompanying drawings.

DETAILED DESCRIPTION OF THE INVENTION

The present invention is directed towards an injection molding apparatus having a nozzle with multiple nozzle bodies arranged in tandem. FIG. 1A shows an injection molding apparatus 10 of the present invention. The injection molding apparatus 10 comprises a manifold 12 having a manifold channel 14 extending therethrough. A manifold bushing 16 is located at an inlet of the manifold channel 14 to receive a melt stream of moldable material from a machine nozzle (not shown) and to deliver the melt stream to manifold outlets 18. A heating element (not shown) heats manifold 12 to maintain the melt stream at a desired temperature. The heating element of the manifold may be embedded into or attached to a surface of the manifold 12.

FIG. 1A shows a first nozzle 20 and a second nozzle 24, each positioned in an opening 33 formed in mold plates 34a and 34b of a split mold plate 34. Nozzles 20 and 24 are positioned between the manifold 12 and a respective mold cavity 30, which is defined by mold plates 34b and 34c of split mold plate 34. Nozzle 20 includes a single nozzle body 22 having an upstream nozzle head 28 and a downstream nozzle end 32. A nozzle channel 25 (shown in shadow) extends through nozzle 20 for delivering the melt stream from one manifold outlet 18 to the corresponding mold cavity 30 through a mold gate 59. Nozzle 20 is further provided with a single heater 42, which helps to maintain the melt stream at a desired temperature as it passes through nozzle 20. Heater 42 is powered through an electrical connector 44 that is in communication via leads (not shown) to a power source (not shown) external to injection molding apparatus 10. Nozzle 20 also includes a nozzle tip 54 retained in a downstream end 32 of nozzle 20 via a threaded connection 36 with nozzle body 22.

FIG. 1A also shows a second nozzle 24 that includes two nozzle bodies, an upstream nozzle body 26 and a downstream nozzle body 27, for delivering a melt stream from a manifold outlet 18 to mold cavity 30. Upstream nozzle body 26 and downstream nozzle body 27 are connected by a removable, yet secure connection (not shown), such as a threaded connection. The mold cavity adjacent nozzle 24 may be a different section of the same mold cavity as that into which melt is delivery via nozzle 20, as shown by mold cavity 30 in FIG. 1A. Alternatively, nozzle 24 may be adjacent a different mold cavity than nozzle 20. Upstream nozzle body 26 includes a first heater 58a powered through a first electrical connector 62a. Downstream nozzle body 27

4

includes a second heater 58b, powered through a second electrical connector 62b. Leads (not shown) for electrical connector 62b may be drawn through a bore 11 positioned between mold plates 34a and 34b. In an alternate embodiment, lead for the electrical connection to a heater in a downstream nozzle body may be drawn along the nozzle through opening 33 formed in split mold plate 34. In this case, the leads exit the injection molding apparatus near an upstream end of the nozzle, as shown in FIGS. 4, 5A, 5B, 6 and 7, which are each discussed in detail below. Nozzle 24 also includes a nozzle tip 54 retained in a downstream end 32 of the downstream nozzle body 27 via a threaded connection 36.

Mold gates 59 are provided at the entrance to the mold cavity 30. The mold gates 59 are selectively openable to allow melt to be delivered to the mold cavities 30. Nozzles 20 and 24 may be thermal gated or valve gated (discussed further with respect to FIG. 2). Each manifold outlet leads to a nozzle which, in turn, extends to the mold gate of an injection mold cavity. Manifolds have various configurations, depending upon the number and arrangement of the nozzles and the corresponding injection mold cavities. For example, a manifold heater may be located in a variety of locations, as is known by those skilled in the art.

FIG. 1B illustrates an alternate embodiment of an injection molding apparatus 110. The embodiment of FIG. 1B includes a first nozzle 124a which is identical to nozzle 24 described above in FIG. 1A, including an upstream nozzle body 26 securely connected to a downstream nozzle body 27, preferably via a threaded connection. Downstream nozzle body 27 includes a nozzle tip 54 retained in a downstream end 32 by a threaded connection 36. Injection molding apparatus 110 also includes a second nozzle 124b which also includes an upstream nozzle body 126 and a downstream nozzle body 127. However, as seen with downstream nozzle body 127, the lengths of upstream and downstream nozzle bodies 126 and 127 may be varied to create several different nozzle lengths. Thus, the particular nozzle lengths may be customized by adding or removing nozzle bodies of various lengths. In FIG. 1B, upstream nozzle bodies 26 and 126 are slightly different lengths and have different connections to manifold 12, which are discussed in detail below. However, an injection molding apparatus of the present invention may alternatively have a uniform length for all upstream nozzle bodies and a different length of downstream nozzle bodies to customize the apparatus for a particular mold.

FIG. 2 shows a portion of an injection molding apparatus 210 of the present invention, including a manifold 212 and a nozzle 224, which is generally positioned within an opening 233 in a mold plate 234. In FIG. 2, nozzle 224 has at least an upstream nozzle body 226 and a downstream nozzle body 227, which define a nozzle channel 225 in fluid communication with a manifold channel (not shown) in manifold 212. Upstream nozzle body 226 may be made from the same material as downstream nozzle body 227, or it may be made from a different material than downstream nozzle body 227. Generally, upstream and downstream nozzle bodies 226 and 227 are made from the same tool steel, H13 or stainless steel.

Upstream nozzle body 226 has an upstream end 246 and a downstream end 247. Upstream end 246 is shown in FIG. 2 coupled to manifold 212 via a removable secure connection 248. In particular, connection 248 includes upstream end 246 having a first set of threads 249 and the manifold 212 having a second set of threads 250, which interlock to fasten upstream nozzle body 226 to manifold 212.

FIG. 2 shows a threaded connection 251 coupling downstream end 247 of upstream nozzle body 226 to an upstream

end **252** of downstream nozzle body **227**, similar to threaded connection **248**. Threaded connection **251** is removable so that downstream nozzle **227** may be replaced if damaged or if a different length is required. As discussed above with respect to FIG. 1B, nozzle bodies of other lengths, either longer or shorter, may be coupled together to provide a customized nozzle **224** of a particularly desired length, such that a single manifold may utilize several different nozzles of various lengths. Further, a threaded connection is a secure connection created by interlocking threads, reducing leakage between upstream nozzle **226** and downstream nozzle **227**.

A removable nozzle tip **254** is inserted into a downstream end **253** of downstream nozzle body **227** and retained by a threaded connection **255** with the downstream end **253** of downstream nozzle body **227**. Because each of the connections **248**, **251** and **255** are secure connections, nozzle bodies may not shift or move with respect to one another to account for thermal expansion. Consequently, nozzle **224** lengthens and presses against the mold plate as nozzle bodies thermally expand. Thus, expansion pressure may result in contact between nozzle **224** and mold plate **234** and wearing at the point of contact therebetween. In the present invention, however, any wear is limited to the easily replaceable nozzle tip **254** which is in contact with mold plate **234**, avoiding expensive and difficult replacement of the entire downstream nozzle body **227**.

Nozzle tip **254**, may be made of a material that is the same or different from the material of downstream nozzle body **227**. For example, nozzle tip may be made from a material having a higher coefficient of thermal conductivity than the downstream nozzle body, such as copper. Preferably, nozzle tip is made from a material having good thermal and heat conductive characteristics, such as H13, tool steel or stainless steel. As such heat may be easily transferred from the adjacent downstream nozzle body **227**, such that a separate heater is not needed in the nozzle tip **254**.

Downstream nozzle body **227** also includes a flange **256** that extends in a radial direction from downstream end **253**. Flange **256** has a tip **256a** that contacts the mold plate **234** and positions downstream nozzle body **227** so that part of nozzle channel **225** formed by nozzle tip **254** is aligned with a mold gate **259** opening into a mold cavity (not shown). flange **256** may be made of a material with a lower thermal conductivity than the material of downstream nozzle body **227** in order to prevent heat loss to the mold plate **234** from downstream nozzle body **227**.

To maintain melt in nozzle channel **255** at a consistent temperature, nozzle **224** has a first heater **258a** embedded into upstream nozzle body **226** including a first electrical connection (not shown). A first thermocouple **263a** for monitoring the temperature of upstream nozzle body **226** and for controlling first heater **258a** is also embedded into upstream nozzle body **226**. Nozzle **224** also includes a second heater **258b** including a second electrical connection **262** and a second thermocouple **263b** for monitoring the temperature of downstream nozzle body **227** and for controlling second heater **258b**. Heaters are coiled closer together at the upstream and downstream end of a nozzle body and looser in the center of a nozzle body because heat loss from the nozzle body occurs via contact with other components at the upstream and downstream ends. For example, sufficient heat is transferred from downstream nozzle body **227** to nozzle tip **254** and further to mold plate **234** to require additional heat to a downstream end **253** of downstream nozzle body **227**. Similarly, heat is lost at the upstream end of upstream nozzle body **226** by transfer to manifold **212**.

Nozzle **224** is a valve gated nozzle and includes a valve pin **238** that is driven by a valve actuator (not shown), typi-

cally a piston, such as that shown as reference number **540** in FIG. 5B. Each valve pin **238** is selectively movable to open and close the respective mold gates **259**. Valve pin **238** running through nozzle channel **225** along the length of nozzle **224** is shown in a split view in FIG. 2 to demonstrate a retracted, or opened, position **238a** and an extended, or closed, position **238b** at the downstream end **253** of downstream nozzle **227**. The downstream end **253** of downstream nozzle **227** also includes a valve pin guide **246** to help guide the valve pin into the mold gate **259**. Valve pin guide **246** includes channels allowing melt to backflow past the valve pin **238** when it is extending to close mold gate **259**.

Under certain conditions, a threaded connection, such as connections **248**, **251**, and **255**, may suffer from thread galling. Thread galling occurs when pressure builds between the contacting and sliding thread surfaces during the process of fastening the threads together. Protective oxides are broken, possibly wiped off, and interface metal high points shear or lock together. In some cases, the shearing may cause the threads to freeze together, so that the connections cannot be unthreaded. Several methods are available to reduce thread galling, such as using threads of different materials. Thus, thread galling may be avoided by having upstream nozzle body **226** be a different material than downstream nozzle body **227**. Alternatively, one set of the threads of connections **248**, **251**, **255** may be coated with a layer of a different material, preferably a lubricating material such as copper, copper alloys, graphite, bronze, brass, or other material as would be apparent to one skilled in the art.

An alternate embodiment of an injection molding apparatus **310** is shown in FIG. 3. This embodiment includes a spacer **366** which defines a portion of nozzle channel **325**. Spacer **366** is one of several devices that may be used to couple upstream nozzle body **326** and downstream nozzle body **327**. In this case, spacer **366** has an upstream threaded end **367** threaded into downstream end **347** of upstream nozzle body **326** and a downstream threaded end **368** threaded into an upstream end **368** of downstream nozzle body **327**. Spacer **366** may provide threads of a different material than upstream nozzle body **326** and downstream nozzle body **327** to avoid thread galling. Depending upon the material it is made from, spacer **366** may act as an insulator to avoid heat transfer between upstream and downstream nozzle bodies **326**, **327** or as a heat sink to avoid overheating in the center of nozzle **324**.

FIG. 4 shows another embodiment of an injection molding apparatus **410** of the present invention including nozzle **424** having three nozzle bodies, i.e., a upstream nozzle body **426**, a downstream nozzle body **427** and an intermediate nozzle body **470**. These nozzle bodies define a nozzle channel **425** fluidly connected to a manifold channel **413**. FIG. 4 also show a split mold plate **434**, similar to that shown in FIGS. 1A and 1B, including separate mold plates **434a**, **434b** and **434c**. In another embodiment, another nozzle (not shown) connected to manifold **412** may be shorter and inject melt into a different mold cavity formed between mold plates **434a** and **434b** or between mold plates **434b** and **434c**; while, an extended nozzle, such as nozzle **424** injects melt into yet another mold cavity (not shown) formed below mold plate **434c**. Mold plates **434a**, **434b** and **434c** are pressed and held together during the molding process, such as by bolts **435**, but released when the molded article has cured to eject the molded article formed therebetween. By using a split mold **434**, one manifold **412** can inject melt into different molds on more than one linear plane, this being able to form more or larger molded articles with a single manifold **412**. Split mold plate **434** may have more or less mold plates

forming a variety of configurations in an injection molding apparatus of the present invention, as would be apparent to one skilled in the art.

As seen in FIG. 4, a downstream end 447 of upstream nozzle 426 is coupled to an upstream end 471 of intermediate nozzle body 470 by a threaded connection 451, and downstream end 472 of intermediate nozzle body 470 is coupled to an upstream end 452 of downstream nozzle body 427 by a threaded connection 473. Because of the length of an extended nozzle, such as nozzle 424, a small misalignment of the valve pin 438 in an upstream area of nozzle 424 may skew the valve pin so as to be greatly misaligned downstream at a mold gate 459. Thus, valve pin guides 474a, 474b and 474c may be positioned along the length of nozzle 424. For example, in FIG. 4, valve pin guided 474a is positioned in recess 490 formed by upstream nozzle body 426 and intermediate nozzle body 470 and is retained by threaded connection 451. Valve pin guide 474b is positioned similarly in a recess 491 between intermediate nozzle body 470 and downstream nozzle body 427 and retained by threaded connection 473. Valve guide 545(a) is positioned and retained, similar to valve pin guide 264 in FIG. 2, by nozzle tip 54.

Each of valve pin guides 474a, 474b and 474c comprise one or more channels therein (not shown) to allow melt to flow past each of valve pin guides 474a, 474b and 474c, while maintaining the alignment of the valve pin 438 in the center of nozzle channel 425 and aligned with mold gate 459. The valve pin guides may be made of the same material or a different material than that of nozzle bodies 426, 470 and 427. Further, the valve pin guides may be made of a material that has a high coefficient of thermal expansion. Therefore, as valve pin guides 474a and 474b thermally expand, each creates a seal and additional support for threaded connections 451 and 473. Further, downstream end 453 of downstream nozzle body 427 includes a flange 456 which contacts mold plate 434c to align nozzle 424 with mold gate 459, as discussed above with respect to FIG. 2.

To further guide the valve pin 438 and keep it aligned with mold gate 459, a pin support 475 is positioned between the upstream end 446 of upstream nozzle body 426 and manifold 412. Pin support 475 includes a melt channel 476 which is aligned and in fluid communication with manifold channel 414 at an upstream end 476a and which nozzle channel 425 at a downstream end 476b.

Nozzle 424 comprises heaters 458a, 458b and 458c, respectively embedded into nozzle bodies 426, 470, and 427, as well as electrical connections 462a, 462b, and 462c, respectively connected to heaters 458a, 458b and 458c. Nozzle 424 also includes thermocouples for monitoring the temperature of each of the nozzle bodies 426, 470 and 427 and for controlling each heaters 458a, 458b and 458c, such as thermocouple 460 shown embedded into downstream nozzle body 427 in FIG. 4.

Downstream nozzle body 427 includes a nozzle tip 454 inserted into a downstream end 453. Nozzle tip 454 is similar to nozzle tip 254 defined and described with respect to FIG. 2. As discussed above, nozzle 424 will elongate due to thermal expansion, upon which nozzle tip 454 will be pressed against mold plate 434c. Because nozzle tip 454 is removable, it can be easily replaced when this pressure causes wear to nozzle tip 454. Further, a separate heater for nozzle tip 454 is not necessary, as it is sufficiently heated by heat transferred from downstream nozzle body 427.

Upstream end 446 of upstream nozzle body 426 is not secured to pin support 475 by a threaded connection as discussed above with respect to FIG. 2. Instead, features of the

arrangement between upstream nozzle body 426 and pin support 475 are discussed in detail below with respect to FIGS. 5A and 5B and with respect to FIG. 10 in U.S. patent application Ser. No. 10/357,420, filed Feb. 4, 2003 (now U.S. Pat. No. 6,860,732), which is incorporated herein by reference in its entirety.

FIGS. 5A and 5B are enlarged views of other injection molding apparatuses 510 and 510a, respectively, of the present invention. Injection molding apparatus 510 of FIG. 5A is not a valve gated injection molding apparatus, and thus does not include a pin support between a manifold 512 and an upstream end 546 of a upstream nozzle body 526. Meanwhile, FIG. 5B illustrates an injection molding apparatus which is valve gated, but without a pin support positioned between a manifold 512 and an upstream end 546 of upstream nozzle body 526.

In the embodiment of FIG. 5A, upstream end 546 includes an upstream surface 546a which abuts a downstream surface 512a of manifold 512 and a shoulder 577 extending in a radial direction. A sleeve 579 is located between a lower surface 577a of shoulder 577 and a contact surface 543d of the manifold plate 543. Sleeve 579 is made of a material having a low thermal conductivity, for example titanium or ceramic, to act as insulation to prevent heat transfer from upstream nozzle body 526 to mold plate 543. Sleeve 579 also includes a cavity 579a to limit the contact between sleeve 579 and contact surface 543d of mold plate 543, reducing the heat loss from upstream nozzle body 526 even further. As would be apparent to one of ordinary skill in the art, sleeve 579 positions and aligns upstream nozzle body 526, and thus nozzle 524, with respect to manifold 512 and a mold gate. Sleeve 579 also includes an opening 579b through which leads for electrical connections 562b/562c extend to be externally connected to a power source.

Upstream end 546 of upstream nozzle body 526 includes a recess 526a that is formed in upstream surface 546a. The recess 526a is delimited by a shoulder 526b. A sealing insert 580 defining a portion of nozzle channel 525 is nested in recess 526a. When injection molding apparatus 510 is in a cold condition a clearance (not shown) is provided between sealing insert 580 and downstream surface 512a of manifold 512.

Sealing insert 580 has a higher coefficient of thermal expansion than both manifold 512 and upstream nozzle body 526, which are typically comprised of tool steels such as H13 or P20 steel, for example. Sealing insert 580 may be comprised of copper, beryllium copper, brass, carbide or some steels. Alternatively, any suitable material having a higher coefficient of thermal expansion than manifold 512 and upstream nozzle body 526 may be used for sealing insert 580.

In operation, the injection molding apparatus 510 starts in the cold condition, in which all of the components are at generally the same ambient temperature. During operation, manifold 512 and multiple nozzle bodies, such as upstream nozzle body 526, are heated and maintained at their respective temperatures so that the melt stream may flow unhindered into a melt cavity, which is chilled. As injection molding apparatus 510 is heated to operating temperature (as shown in FIGS. 5A and 5B), sealing insert 580 expands. Because sealing insert 580 has a higher coefficient of thermal expansion, the length of sealing insert 580 increases by a larger amount than the surrounding components, including upstream end 546 of upstream nozzle body 526 and manifold 512. As such, sealing insert 580 applies a sealing force to downstream surface 512a of manifold 512. The expansion

of the sealing insert **580** may, in fact, cause upstream surface **546a** of upstream nozzle body **526** and downstream surface **512a** of manifold **512** to push apart slightly, however, fluid communication between the components is sealed, providing a continuous, sealed path for melt to flow between manifold channel **514** and nozzle channel **225**.

Further, since there is no secured connection between manifold **512**, upstream nozzle body **526** and sleeve **579**, these components can shift upon thermal expansion to relieve some of the pressure created by the secured connections between the plurality of nozzle bodies due to thermal expansion.

Returning to FIG. 4, sleeve **479** positions and aligns upstream nozzle body **426** and thus nozzle **424** with respect to manifold **412**, pin support **475** and mold gate **459**. Sleeve **479** and sealing ring **480** operate as discussed above with respect to sleeve **579** and sealing ring **580** of FIG. 5A, except that sealing ring **580** creates a seal with respect to pin support **475** instead of directly with manifold **412**. Similarly, FIG. 5B, illustrates a valve gated injection molding apparatus **510a**, including a valve pin **538**, however, without a pin support. Upstream end **546** of upstream nozzle body **526** is further positioned with respect to manifold **512** via having sleeve **579** and seal insert **580**, as discussed above with respect to FIG. 5A. FIG. 5B also shows an actuator **540** for retracting and extending valve pin **538** within a nozzle channels **525**. Actuator **540** is a hydraulic or pneumatic piston that moves up and down via pressure changes created as a fluid flows in an out of the actuator via lines **541**.

FIG. 6 shows another injection molding apparatus **610** of the present invention. Injection molding apparatus **610** is similar to injection molding apparatus of FIG. 4, except that each of an upstream nozzle body **626**, an intermediate nozzle body **670**, and a downstream nozzle body **627** includes at least two independent heaters embedded therein, respectively. For example, heaters **658a** and **658a'** are embedded into upstream nozzle body **626**. Although not shown in FIG. 6, heaters **658a** and **658a'** are both connected via separate electrical connections, such as electrical connection **662a**. Similarly, intermediate nozzle body **670** has embedded therein heaters **658b** and **658b'**, with electrical connections **662b** and **662b'**, respectively. Finally, heaters **658c** and **658c'** are embedded into downstream nozzle body **627**, with electrical connections **662c** and **662c'**, respectively. Having two or more heaters embedded in a nozzle body adds additional heat to the nozzle bodies. Further, each of nozzle bodies **626**, **670** and **627** also include an embedded thermocouple for monitoring the temperature of the nozzle body and for controlling heaters **658a**, **658a'**, **658b**, **658b'**, **658c** and **658c'**, such as thermocouple **660** embedded into downstream nozzle body **627** shown in FIG. 6.

FIG. 7 shows another injection molding apparatus **710** of the present invention. In this embodiment, injection molding apparatus **710** is also similar to injection molding apparatus of FIG. 4, except that an upstream nozzle body **726**, an intermediate nozzle body **770** and a downstream nozzle body **727** are each surrounded by heating bands **780a**, **780b** and **780c**, respectively. Embedded within heating bands **780a**, **780b** and **780c**, are heaters **782a**, **782b** and **782c**, respectively. Heating bands supplement that heat provided to nozzle bodies **726**, **770** and **727** by heaters **758a**, **758b** and **758c**, respectively, which are embedded within the nozzle bodies. Heating bands may be made from a different material, preferably a high thermally conductive material, and may be attached to the nozzle bodies by a mechanical means such as welding or brazing or by another method apparent to one skilled in the art. Further, heating band heaters **782a**, **782b**,

and **782c** have separate electrical connections, i.e., a connection (not shown) for band heater **782a** and connections **783b** and **783c** for band heaters **782b** and **782c**, respectively, than the electrical connections **762a**, **762b**, and **762c** for heaters **758a**, **758b** and **758c**, as shown in FIG. 7. Finally, the temperature of each nozzle body **726**, **770** and **727** is monitored by, and both heating band heaters **782a**, **782b** and **782c** and heaters **758a**, **758b** and **758c** are controlled by, thermocouple place in each nozzle body, such as thermocouple **760** embedded into downstream nozzle body **727**, as shown in FIG. 7.

FIGS. 8A and 8B illustrate an aspect of yet another embodiment of an injection molding apparatus **810** of the present invention. FIGS. 8A and 8B illustrate an enlarged view of a downstream nozzle body **827** of a nozzle **824**.

A nozzle tip **854**, retained in a downstream end **853** of downstream nozzle body **827** by a second connection, has an extended portion **819**. Extended portion **819** slidably fits into a bore **829** in mold plate **834a** which is aligned with mold gate **859** in mold plate **834b**. The extended portion **819** aligns downstream nozzle body **827**, and thus nozzle channel **825**, with mold gate **859**. FIG. 8A shows the position of nozzle tip **854**, when the injection molding apparatus is not being operated and is cold. During operation of injection molding apparatus **810**, nozzle **824** thermally expands. As it does, nozzle tip **954** slides with respect to mold plates **834a**, and **843b**, and extended portion **819** of nozzle tip **854** expands into mold gate **859**, as shown in FIG. 8B. Thus, the slidable coupling between nozzle tip **854** and mold plates **834a** and **834b** relieves the pressure caused by the secure connection between nozzle bodies in tandem. Extended portion **819** also expands in a radial direction, which is perpendicular to the flow of the melt stream, forming a seal with mold plates **834a** and **834b** to prevent leaking of the melt stream.

While the invention has been particularly shown and described with reference to preferred embodiments thereof, it will be understood by those skilled in the art that they have been presented by way of example only, and not limitation, and various changes in form and details can be made therein without departing from the spirit and scope of the invention. For example, multiple nozzle bodies can be used in an injection molding apparatus of the present invention. As such, the number of nozzle bodies is not limited to either two or three as shown in the figures.

Thus, the breadth and scope of the present invention should not be limited by any of the above-described exemplary embodiments, but should be defined only in accordance with the following claims and their equivalents. Additionally, all references cited herein, including issued U.S. patents, or any other references, are each entirely incorporated by reference herein, including all data, tables, figures, and text presented in the cited references.

The foregoing description of the specific embodiments will so fully reveal the general nature of the invention that others can, by applying knowledge within the skill of the art (including the contents of the references cited herein), readily modify and/or adapt for various applications such specific embodiments, without undue experimentation, without departing from the general concept of the present invention. Therefore, such adaptations and modifications are intended to be within the meaning and range of equivalents of the disclosed embodiments, based on the teaching and guidance presented herein. It is to be understood that the phraseology or terminology herein is for the purpose of description and not of limitation, such that the terminology or phraseology of the present specification is to be inter-

11

preted by the skilled artisan in light of the teachings and guidance presented herein, in combination with the knowledge of one of ordinary skill in the art.

What is claimed is:

1. An injection molding apparatus, comprising:
a hot runner manifold including at least two manifold channels;
at least two nozzles, each of said at least two nozzles defining a nozzle channel in fluid communication with a respective one of said at least two manifold channels;
at least one of said at least two nozzles including nozzle bodies coupled together said nozzle bodies including at least an upstream nozzle body having an upstream end adjacent said manifold channel and a downstream end, and a downstream nozzle body having a downstream end adjacent a mold plate and an upstream end directly adjacent the downstream end of the upstream nozzle body;
a separate and removable nozzle tip retained in said downstream end of said downstream nozzle body; and
another nozzle tip coupled to another one of said at least two nozzles.
2. The injection molding apparatus of claim 1, further comprising a threaded connection configured to removably couple said nozzle bodies.
3. The injection molding apparatus of claim 2, wherein said threaded connection includes a first set of threads and a second set of threads, wherein said first set of threads are made of a material that is different from said second set of threads.
4. The injection molding apparatus of claim 2, wherein at least one of said upstream body or downstream nozzle body includes threads made from a material that is different from said nozzle bodies.
5. The injection molding apparatus of claim 1, wherein at least one of said nozzles includes an intermediate nozzle body, wherein an upstream end of said intermediate nozzle body is removably fastened to said downstream end of said upstream nozzle body and a downstream end of said intermediate nozzle body is removably fastened to said upstream end of said downstream nozzle body.
6. The injection molding apparatus of claim 1, wherein said nozzle tip is configured to be retained in said downstream nozzle body by a removably fastened connection.
7. The injection molding apparatus of claim 6, wherein said nozzle tip is configured to be retained in said downstream nozzle body via a threaded connection.
8. The injection molding apparatus of claim 1, wherein each of said nozzle bodies includes a heater attached thereto.
9. The injection molding apparatus of claim 8, wherein said nozzle tip does not have a heater attached directly thereto.
10. The injection molding apparatus of claim 1, wherein said upstream end of said upstream nozzle body is threadably connected to said manifold.
11. The injection molding apparatus of claim 1, wherein said upstream end of said upstream nozzle body is slidably connected with said manifold.
12. The injection molding apparatus of claim 1, wherein at least one of said at least two nozzles includes a valve pin and an actuator, the actuator configured for extending and retracting said valve pin.
13. The injection molding apparatus of claim 12, wherein said at least one of said at least two nozzles includes at least one valve pin guide.
14. The injection molding apparatus of claim 12, wherein a pin support is disposed between said upstream end of said upstream nozzle body and said hot runner manifold.

12

15. The injection molding apparatus of claim 1, wherein said nozzle tip is made from a different material than said nozzle bodies.

16. The injection molding apparatus of claim 15, wherein the material making up said nozzle tip has a high thermal conductivity.

17. The injection molding apparatus of claim 1, wherein the mold plate comprises a split mold plate that includes a plurality of mold plates.

18. The injection molding apparatus of claim 1, wherein said nozzle tip includes an extended portion that is slidable within a bore in said mold plate.

19. An injection molding apparatus, comprising:

a manifold defining at least two manifold channels;

at least two nozzles, each of said at least two nozzles defining a nozzle channel in fluid communication with a respective one of said at least two manifold channels an coupled to respective nozzle tips; and

at least one of said at least two nozzles including at least two nozzle bodies, the at least two nozzle bodies including an upstream nozzle body directly connected in tandem with a downstream nozzle body via a removably fastened connection, a respective one of the nozzle tips being disposed in a downstream end of said downstream nozzle body;

wherein each of said at least two nozzle bodies includes at least one heater attached thereto, and

wherein each of said nozzle tips does not have a separate heater connected directly thereto.

20. The injection molding apparatus of claim 19, wherein each of said at least two nozzle bodies has a first heater at least partially embedded therein.

21. The injection molding apparatus of claim 20, wherein each of said nozzle bodies includes at least two heaters.

22. The injection molding apparatus of claim 21, wherein each of said nozzle bodies includes a second heater at least partially embedded therein.

23. The injection molding apparatus of claim 20, wherein at least one of said nozzle bodies includes a second heater embedded in a heating band coupled to said nozzle body.

24. A manifold injection molding apparatus, comprising:
a manifold defining at least two manifold channels;

at least two nozzles, each of said nozzles defining a nozzle channel in fluid communication with a respective one of said at manifold channels; and

at least one of said nozzles including at least two nozzle bodies, including at least a upstream nozzle body and a downstream nozzle body removably fastened in tandem;

wherein each of said nozzle bodies includes at least a first heater and a second heater, wherein each of at least said first heater is embedded into each of said nozzle bodies.

25. The injection molding apparatus of claim 24, wherein each of said second heater is embodied in a heating band surrounding an outside surface of each of said nozzle bodies.

26. The injection molding apparatus of claim 25, wherein said heating band comprises a material having a high thermal conductivity.

27. The injection molding apparatus of claim 24, wherein each of said first heater and said second heater have separate electrical connections extending therefrom.

28. The injection molding apparatus of claim 24, wherein said downstream nozzle body includes an electrical connection for at least one of said first and second heaters with leads exiting said injection molding apparatus through a bore between a first and second mold plate.

29. The injection molding apparatus of claim 24, wherein said downstream nozzle body includes an electrical connection for at least one of said first and second heaters with leads drawn along an opening in a mold plate into which said nozzle is inserted.

30. The injection molding apparatus of claim 24, wherein a nozzle tip is disposed in a downstream end of said downstream nozzle body.

31. The injection molding apparatus of claim 30, wherein said nozzle tip is not heated by a separate heater attached directly thereto.

32. The injection molding apparatus of claim 24, wherein both said first heater and said second heater are embedded in each of said nozzle bodies.

33. An injection molding nozzle apparatus, comprising:
first and second nozzles each having a nozzle channel that is in fluid communication with corresponding first and second manifold channels of a hot runner manifold, at least one of the first and second nozzles including upstream and downstream nozzle bodies coupled together, the upstream nozzle body having an upstream end adjacent the manifold channel and the downstream nozzle body having a downstream end adjacent a mold plate;

removable nozzle tips coupled to each of the first and second nozzles; and

a spacer having a first end threaded to the upstream nozzle body and a second end threaded to the downstream nozzle body.

34. The injection molding nozzle apparatus of claim 33, wherein said spacer is made from a different material than said upstream and said downstream nozzle bodies.

35. The injection molding nozzle apparatus of claim 34, wherein said spacer is an insulator.

36. The injection molding nozzle apparatus of claim 34, wherein said spacer is a heat sink.

37. An injection molding apparatus comprising:
a manifold having a manifold channel;

a nozzle having a nozzle body including an upstream nozzle body, a downstream nozzle body, and a spacer disposed between said upstream nozzle body and said downstream nozzle body such that said upstream nozzle body, said downstream nozzle body, and said spacer collectively define a nozzle channel in fluid communication with said manifold channel, wherein said spacer is connected to said downstream nozzle body such that said spacer is not movable relative to said downstream nozzle body, and wherein said upstream and downstream nozzle bodies are heated and said spacer is devoid of a nozzle heater; and

a nozzle tip coupled to the downstream nozzle body, said nozzle tip for receiving melt from said nozzle channel and delivering the melt to a mold cavity.

38. The injection molding apparatus of claim 37, further comprising:

a first thermocouple coupled to said upstream nozzle body; and

a second thermocouple coupled to said downstream nozzle body.

39. The injection molding apparatus of claim 37, wherein said spacer is removably connected to at least one of said upstream nozzle body and said downstream nozzle body.

40. The injection molding apparatus of claim 37, wherein said spacer is made from a material such that it acts as a heat sink.

41. The injection molding apparatus of claim 37, wherein said spacer is made from a material such that it acts as an

insulator to avoid heat transfer between said upstream nozzle body and said downstream nozzle body.

42. The injection molding apparatus of claim 37, wherein said spacer is connected to said downstream nozzle body using a threaded connection.

43. The injection molding apparatus of claim 37, wherein said spacer is connected to said upstream nozzle body using a threaded connection and is connected to said downstream nozzle body using a threaded connection.

44. The injection molding apparatus of claim 37, wherein said nozzle tip is a single nozzle tip.

45. A nozzle for use in an injection molding apparatus having a manifold and a mold gate, said nozzle comprising:
a first nozzle body disposed adjacent the manifold having a first melt channel;

a spacer having a spacer melt channel; and

a second nozzle body disposed adjacent the mold gate and having a second melt channel, said spacer being disposed between said first nozzle body and said second nozzle body such that said first, second and spacer melt channels collectively define a nozzle melt channel,

wherein said spacer is connected to said second nozzle body such that said spacer is not slidable relative to said second nozzle body, and wherein said first and second nozzle bodies are heated and said spacer is devoid of a nozzle heater.

46. The nozzle of claim 45, wherein said spacer is removably connected to at least one of said first nozzle body and said second nozzle body.

47. The nozzle of claim 45, wherein said spacer is made from a material such that it acts as a heat sink.

48. The injection molding apparatus of claim 45, wherein said spacer is made from a material such that it acts as an insulator.

49. The nozzle of claim 45, wherein said spacer is connected to said second nozzle body via a threaded connection.

50. The nozzle of claim 45, wherein said spacer is connected to said first nozzle body using a threaded connection and is connected to said second nozzle body using a threaded connection.

51. An injection molding apparatus having a plurality of mold gates, said apparatus comprising:
a manifold; and

a plurality of nozzles disposed between said manifold and the mold gates, wherein at least one of said plurality of nozzles has a nozzle body including an upstream nozzle body adjacent said manifold, a spacer, and a downstream nozzle body adjacent one of the mold gates, said spacer disposed between said upstream nozzle body and said downstream nozzle body, and wherein at least two of said nozzles are of different lengths,

wherein said upstream and downstream nozzle bodies of said at least one nozzle are heated and said spacer does not have a heater in contact with it.

52. The injection molding apparatus of claim 51, wherein at least two of said nozzles are in fluid communication with separate mold cavities.

53. The injection molding apparatus of claim 51, wherein said spacer is connected to each of said upstream and downstream nozzle bodies using a threaded connection.

54. An injection molding apparatus comprising:
a manifold having a heater and a manifold melt channel for distributing melt from a manifold inlet to a plurality of manifold outlets;

a nozzle having a nozzle melt channel, the nozzle being coupled to the manifold for receiving the melt from a manifold outlet, the nozzle including:

15

- an upstream nozzle body forming a portion of said nozzle melt channel,
 a downstream nozzle body forming a portion of said nozzle melt channel,
 a spacer forming a portion of said nozzle melt channel and disposed between said upstream and downstream nozzle bodies such that said upstream nozzle body, said downstream nozzle body, and said spacer are coupled together along a common axis, wherein said spacer is made from a material such that it acts as an insulator as compared to said upstream and downstream nozzle bodies, and
 a heater coupled to said upstream and downstream nozzle bodies; and
 a nozzle tip coupled to a downstream end of said downstream nozzle body, said nozzle tip for receiving the melt from said nozzle melt channel and delivering the melt to a mold cavity.
55. The injection molding apparatus of claim 54, wherein said upstream and downstream nozzle bodies are made of the same material.
56. The injection molding apparatus of claim 55, wherein said upstream and downstream nozzle bodies are made of steel.
57. The injection molding apparatus of claim 54, wherein said nozzle heater comprises a first heater coupled to said upstream nozzle body and a second heater coupled to said downstream nozzle body.
58. The injection molding apparatus of claim 57, further comprising a first thermocouple coupled to said upstream nozzle body and a second thermocouple coupled to said downstream nozzle body.
59. The injection molding apparatus of claim 58, wherein said first heater and said second heater are independently controllable.
60. The injection molding apparatus of claim 54, wherein an upstream end of said spacer is directly connected to a downstream end of said upstream nozzle body, and a downstream end of said spacer is directly connected to an upstream end of said downstream nozzle body.
61. The injection molding apparatus of claim 60, wherein said spacer is connected to said upstream and downstream nozzle bodies by threads.

16

62. The injection molding apparatus of claim 54, wherein said spacer is coupled to said upstream and downstream nozzle bodies by threads.
63. An injection molding apparatus comprising:
 a manifold having a heater and a manifold melt channel for distributing melt from a manifold inlet to a plurality of manifold outlets;
 a nozzle having a nozzle melt channel, said nozzle being coupled to said manifold for receiving the melt from a manifold outlet, said nozzle including:
 an upstream nozzle body forming a portion of said nozzle melt channel,
 a downstream nozzle body forming a portion of said nozzle melt channel,
 a spacer forming a portion of said nozzle melt channel, said spacer being disposed between and coupled to said upstream and downstream nozzle bodies such that the spacer substantially limits heat transfer between said upstream nozzle body and said downstream nozzle body, and
 a heater coupled to said upstream and downstream nozzle bodies; and
 a nozzle tip coupled to a downstream end of said downstream nozzle body, said nozzle tip for receiving the melt from said nozzle melt channel and delivering the melt to a mold cavity.
64. The injection molding apparatus of claim 63, wherein said spacer is formed from an insulative material.
65. The injection molding apparatus of claim 63, wherein said upstream and downstream nozzle bodies are made of the same material.
66. The injection molding apparatus of claim 65, wherein said upstream and downstream nozzle bodies are made of steel.
67. The injection molding apparatus of claim 63, wherein said spacer is coupled to said upstream and downstream nozzle bodies by threads.

* * * * *