



US00RE41520E

(19) **United States**  
(12) **Reissued Patent**  
**Quinn**

(10) **Patent Number: US RE41,520 E**  
(45) **Date of Reissued Patent: Aug. 17, 2010**

(54) **GYROSCOPIC POINTER AND METHOD**  
(75) Inventor: **Thomas J. Quinn**, Los Gatos, CA (US)  
(73) Assignee: **Thomson Licensing**, Boulogne, Billancourt (FR)  
(21) Appl. No.: **09/642,250**  
(22) Filed: **Oct. 12, 2000**

5,097,707 A 3/1992 Church  
5,142,655 A 8/1992 Drumm  
5,287,119 A 2/1994 Drumm  
5,288,078 A 2/1994 Capper et al.  
5,329,276 A 7/1994 Hirabayashi  
5,363,120 A 11/1994 Drumm  
5,453,758 A 9/1995 Sato

**Related U.S. Patent Documents**

Reissue of:  
(64) Patent No.: **5,898,421**  
Issued: **Apr. 27, 1999**  
Appl. No.: **08/643,991**  
Filed: **May 7, 1996**

**U.S. Applications:**

(63) Continuation of application No. 08/406,727, filed on Mar. 20, 1995, now abandoned, which is a continuation of application No. 08/000,651, filed on Jan. 5, 1993, now Pat. No. 5,440,326, which is a continuation of application No. 07/497,127, filed on Mar. 21, 1990, now abandoned.  
(51) **Int. Cl.**  
**G09G 5/00** (2006.01)  
(52) **U.S. Cl.** ..... **345/156; 345/157; 345/158; 345/166; 463/37**  
(58) **Field of Classification Search** ..... **345/156-166; 278/148 B; 463/37-38**  
See application file for complete search history.

(56) **References Cited**

**U.S. PATENT DOCUMENTS**

2,309,853 A 2/1943 Lyman et al.  
3,782,205 A 1/1974 Fletcher et al.  
4,267,731 A 5/1981 Jacobson  
4,489,609 A 12/1984 Burdess et al.  
4,580,006 A 4/1986 Hull  
4,601,206 A 7/1986 Watson  
4,639,547 A 1/1987 Jacob-Grinschgl et al.  
4,644,793 A 2/1987 Church  
4,831,544 A 5/1989 Hojo et al.  
4,839,838 A 6/1989 LaBiche et al.  
4,862,152 A 8/1989 Milner  
5,068,645 A 11/1991 Drumm

**FOREIGN PATENT DOCUMENTS**

JP 62-143124 6/1987

**OTHER PUBLICATIONS**

Walter Wrigley et al., "Gyroscopic Theory, Design, and Instrumentation", M.I.T. Press, Jan. 1980.  
Oshima, Mitsuaki, et al., "VHS Camcorder with Electronic Image Stabilizer", IEEE Transactions on Consumer Electronics, vol. 35, No. 4, Nov. 1989, pp. 749-757.  
Analog Devices, Inc., "Analog Devices Introduces the World's Smallest and Least Expensive Micromachined Tilt/Motion Sensor", Copyright 2000, [online], [retrived on Jun. 14, 2000], retrieved from the internet<URL:http://biz.yahoo.com/prnews/000612/ma\_analog\_.html>, pp. 1-2.

*Primary Examiner*—Richard Hjerpe  
*Assistant Examiner*—Leonid Shapiro  
(74) *Attorney, Agent, or Firm*—Robert D. Shedd; Vincent E. Duffy

(57) **ABSTRACT**

A vertical gyroscope is adapted for use as a pointing device for controlling the position of a cursor on the display of a computer. A motor at the core of the gyroscope is suspended by two pairs of orthogonal gimbals from a hand-held controller device and nominally oriented with its spin axis vertical by a pendulous device. Electro-optical shaft angle encoders sense the orientation of a hand-held controller device as it is manipulated by a user and the resulting electrical output is converted into a format usable by a computer to control the movement of a cursor on the screen of the computer display. For additional ease of use, the bottom of the controller is rounded so that the controller can be pointing while sitting on a surface. A third input is provided by providing a horizontal gyroscope within the pointing device. The third rotational signal can be used to either rotate a displayed object or to display or simulate a third dimension.

**47 Claims, 6 Drawing Sheets**

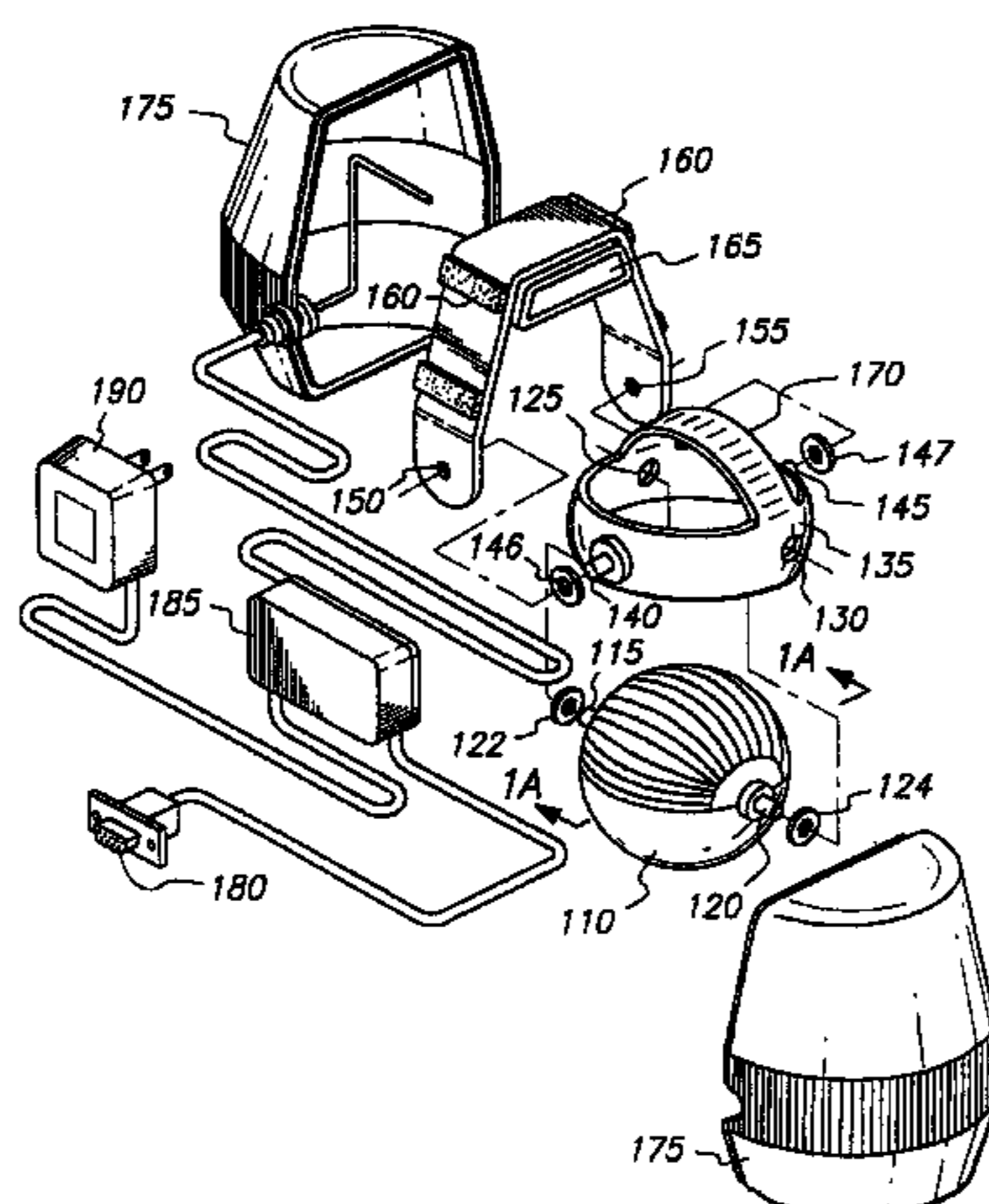

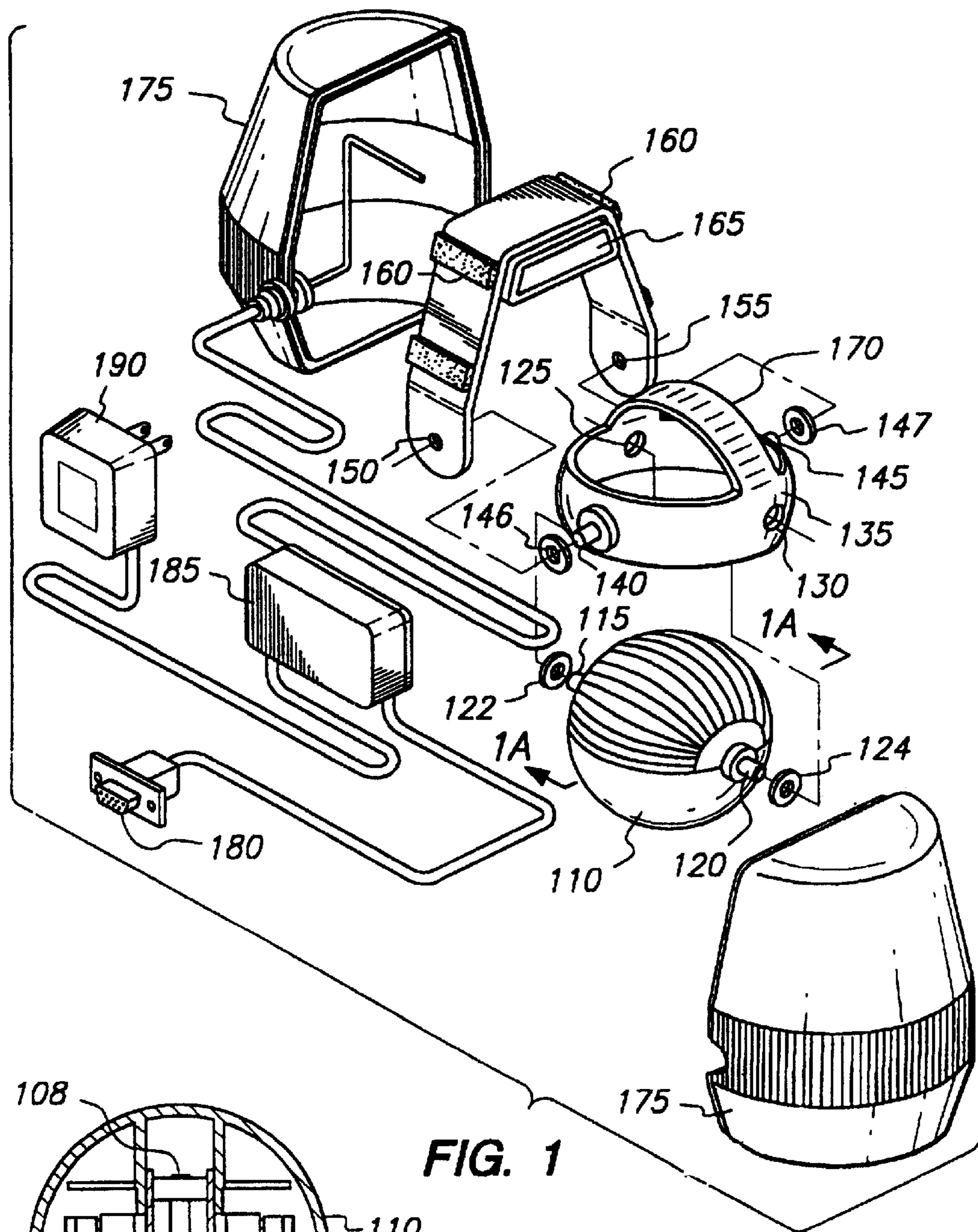

**FIG. 1**

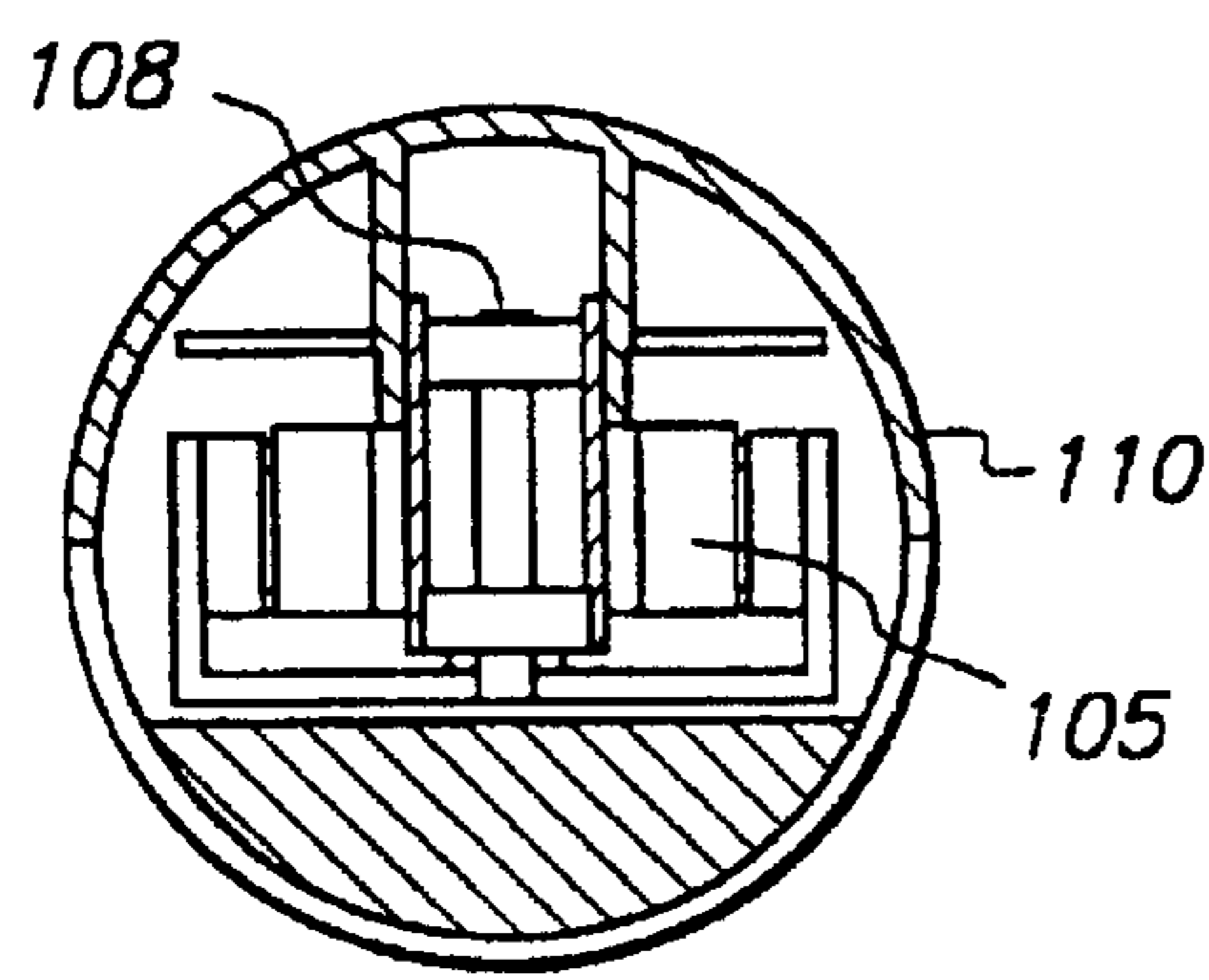

**FIG. 1A**  
(SECTION A-A)

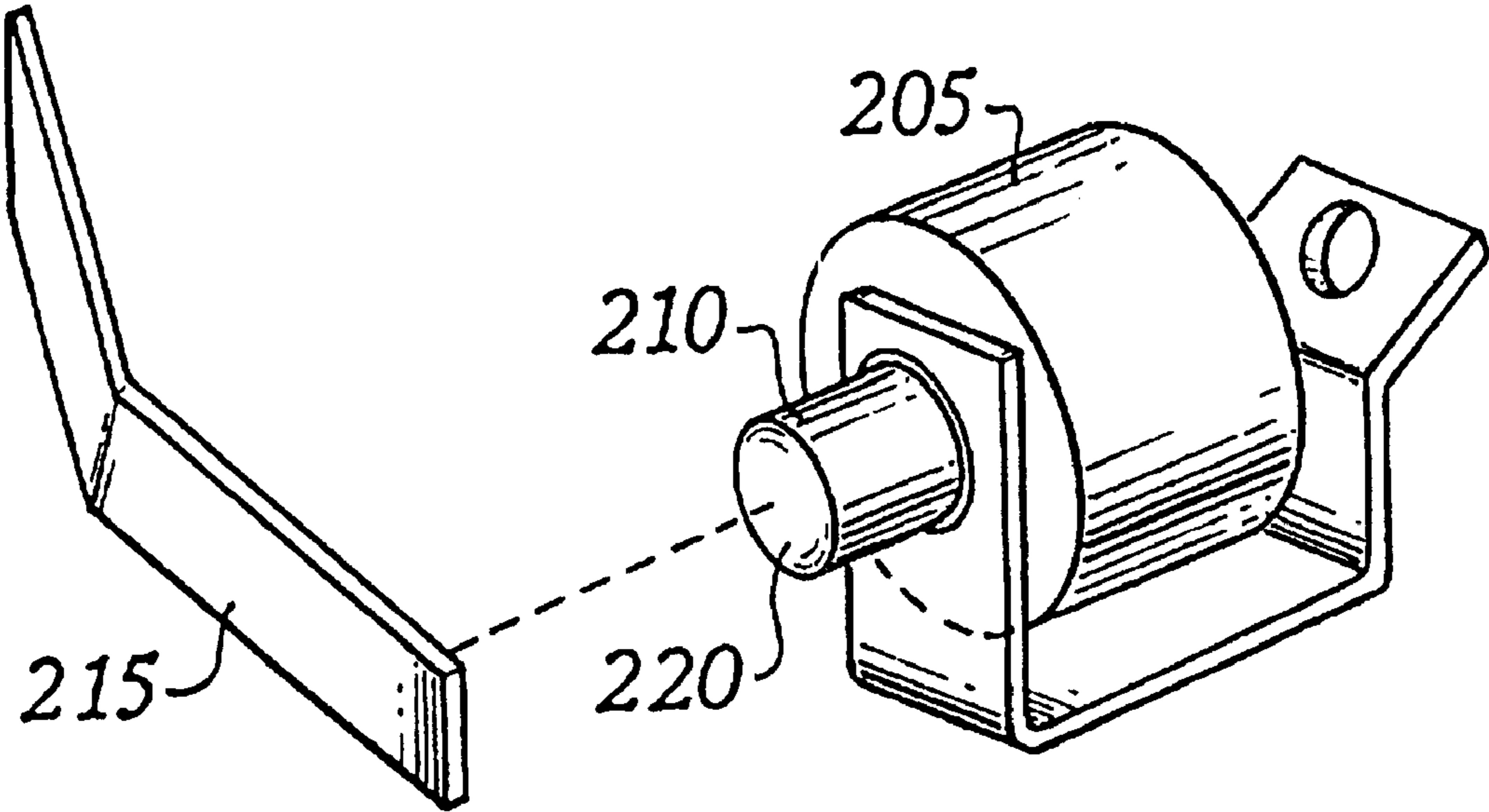
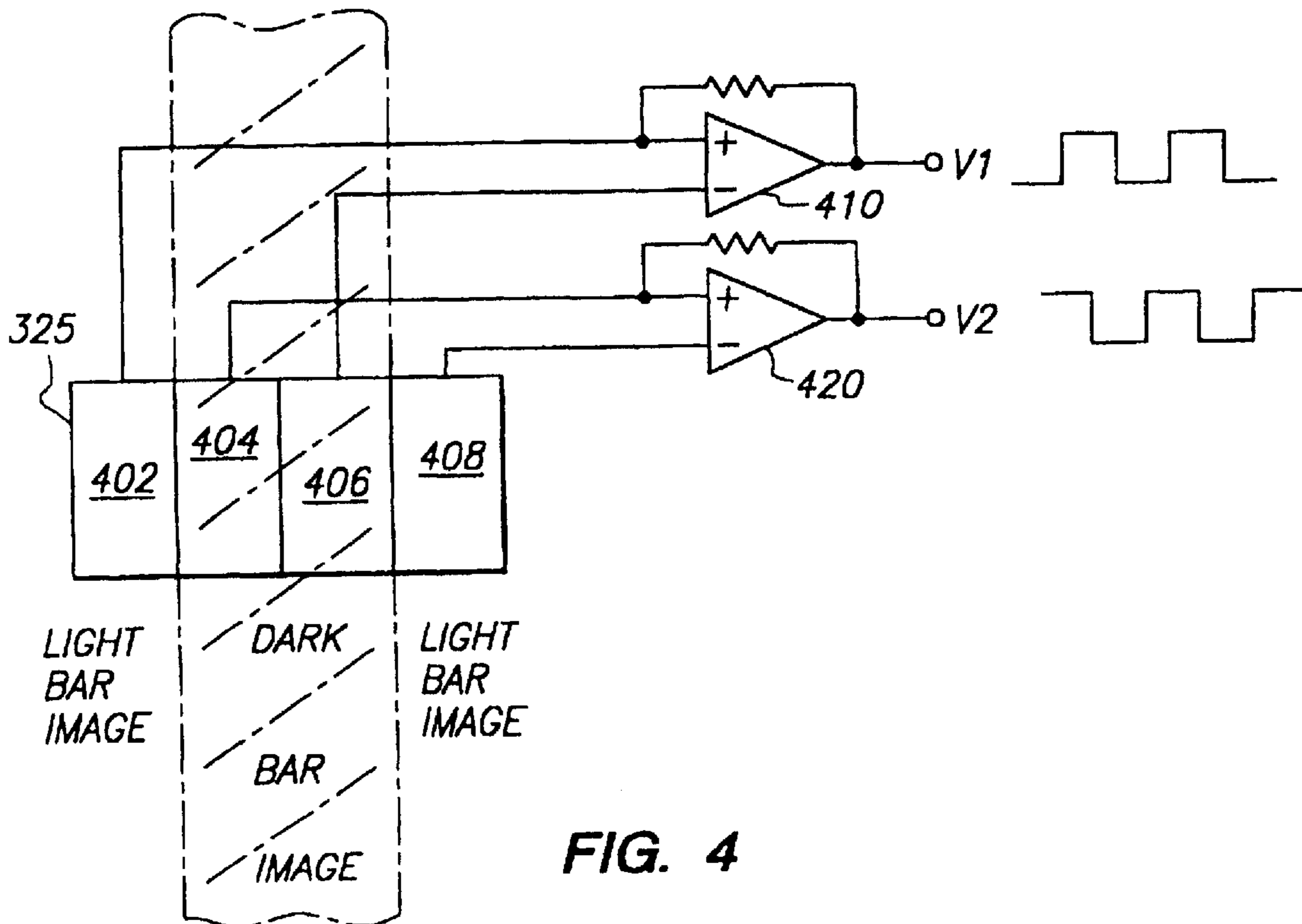
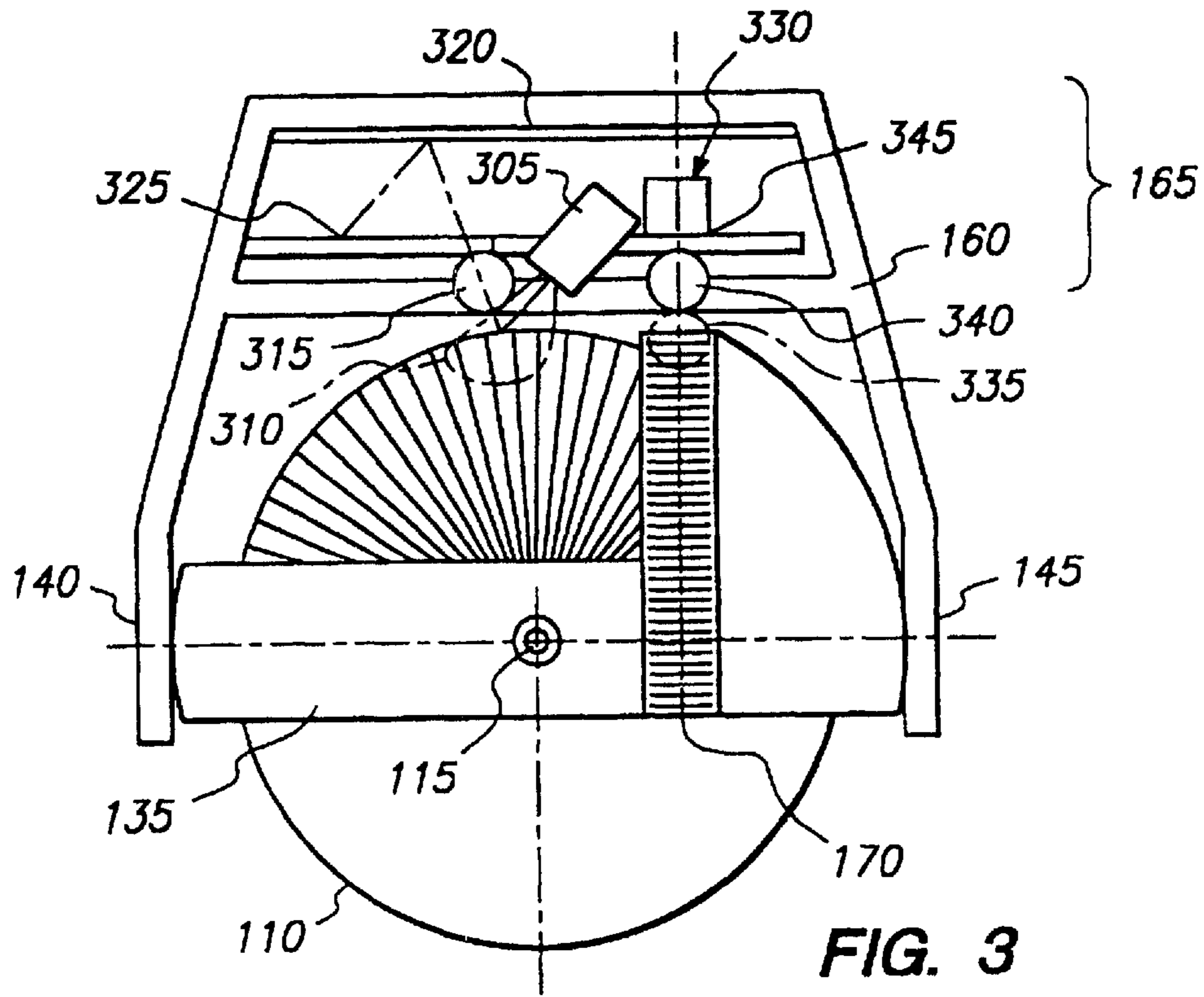

Figure 2



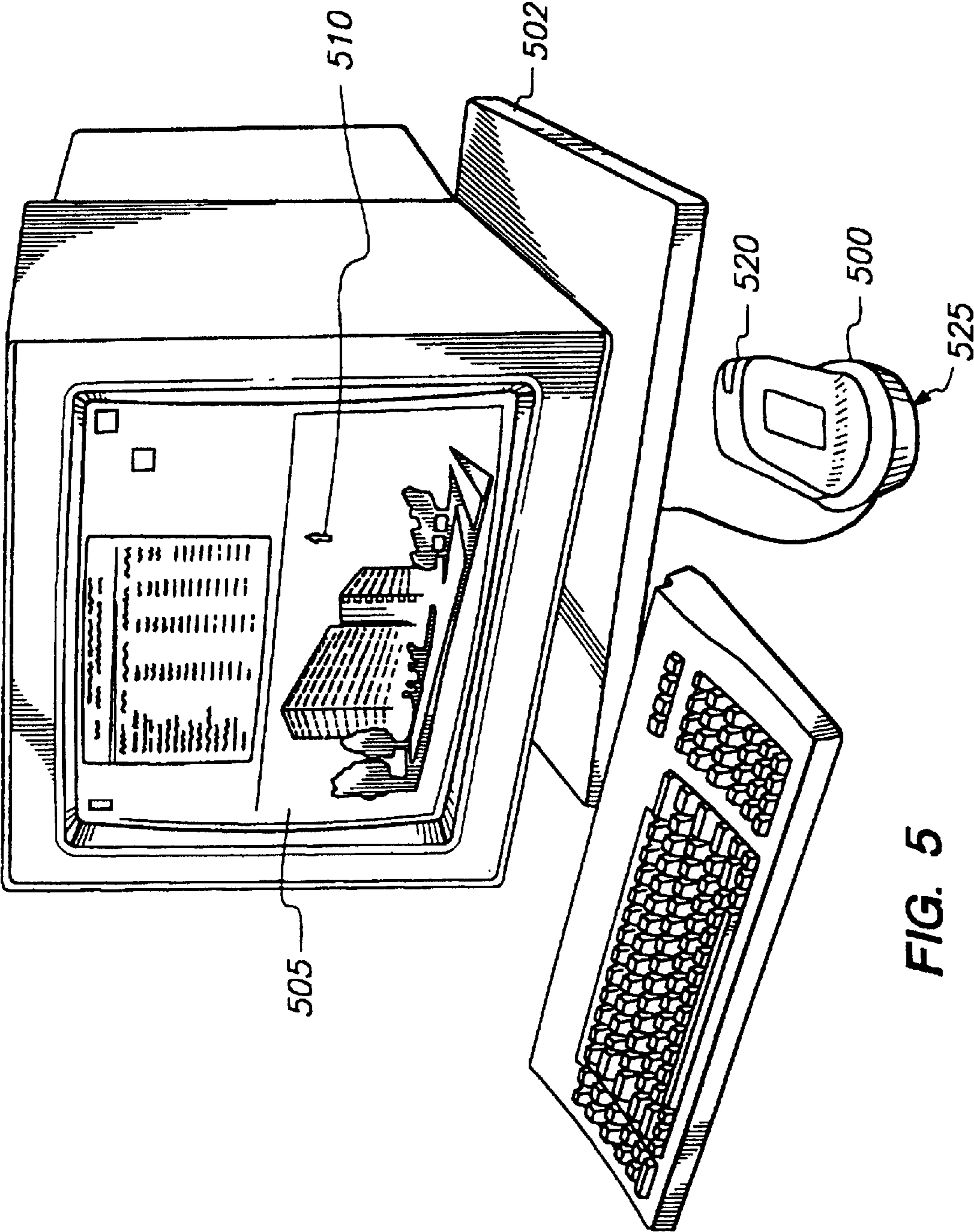

FIG. 5

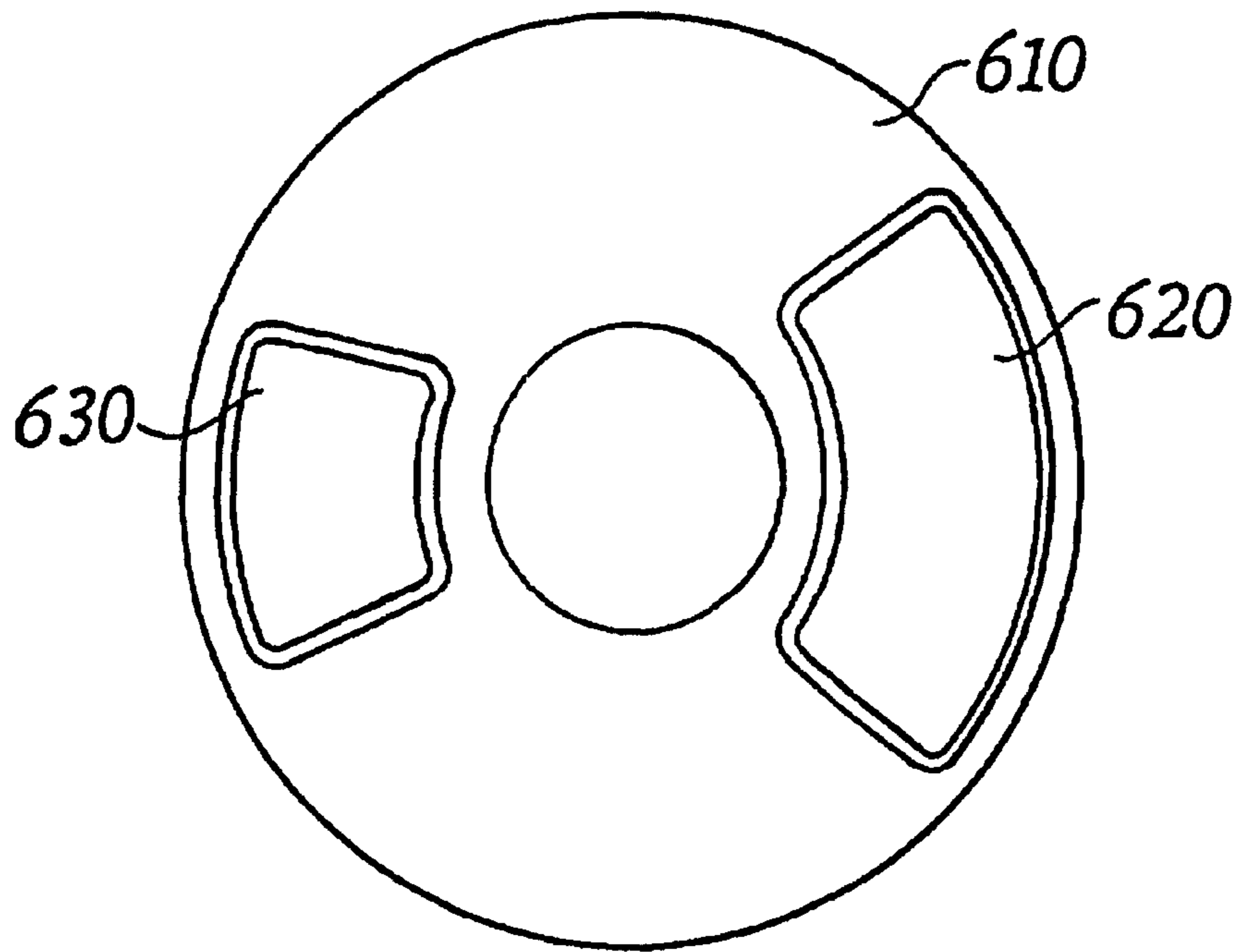

Figure 6

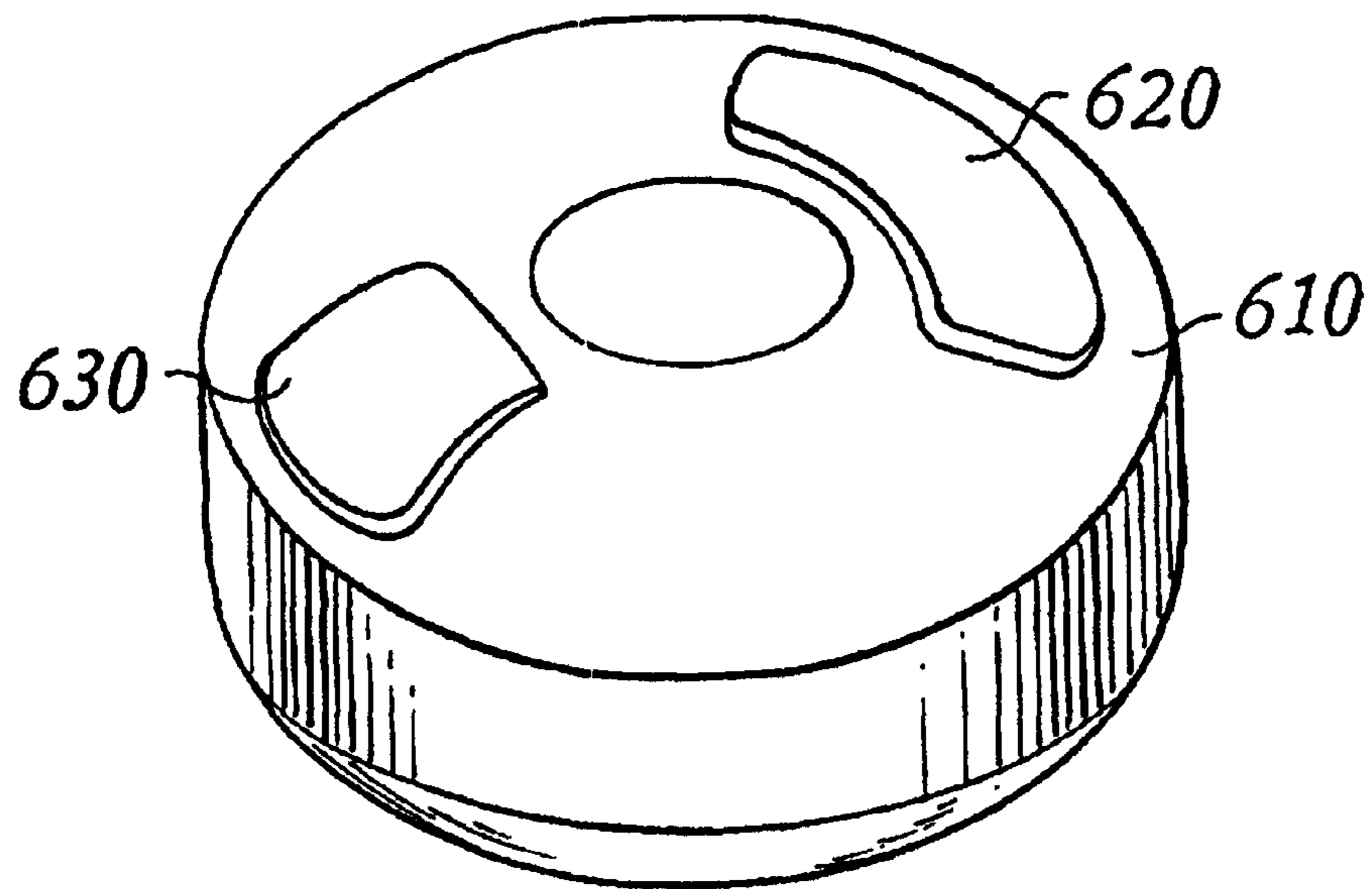
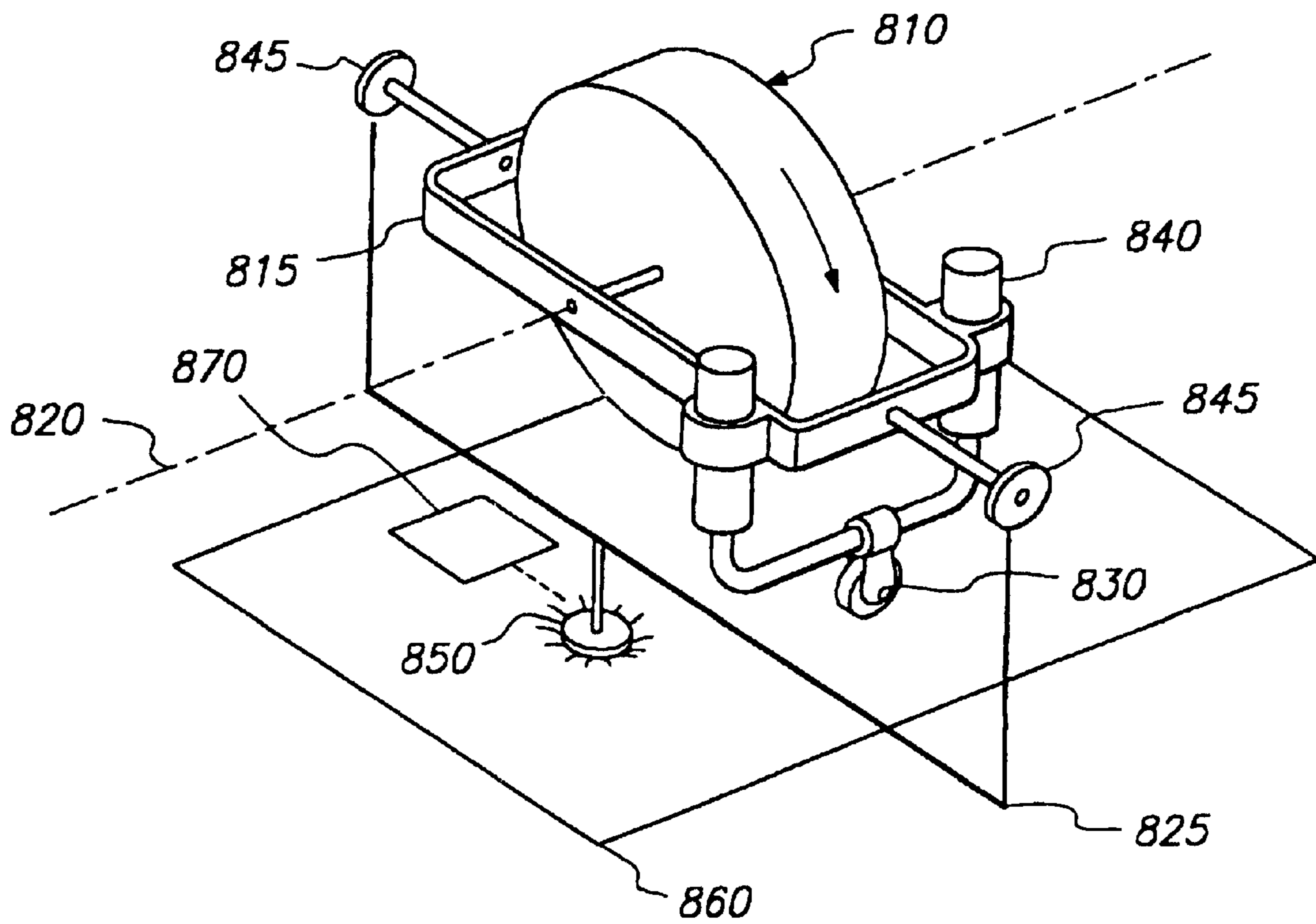

Figure 7



**FIG. 8**

## GYROSCOPIC POINTER AND METHOD

**Matter enclosed in heavy brackets [ ] appears in the original patent but forms no part of this reissue specification; matter printed in italics indicates the additions made by reissue.**

This is a continuation of application Ser. No. 08/406,727, filed on Mar. 20, 1995, now abandoned, which is a continuation of Ser. No. 08/000,651, filed on Jan. 5, 1993, now U.S. Pat. No. 5,440,326, which is a continuation of Ser. No. 07/497,127, filed on Mar. 21, 1990, now abandoned.

## BACKGROUND OF THE INVENTION

## 1. Field

The present invention relates to the field of hand-held computer controllers. More specifically, the present invention relates to a hand-held gyroscopic pointer adapted for use as a cursor-control device for a computer.

## 2. Art Background

## A. Computer controllers:

Historically, computer instructions have taken the form of commands entered as words on a keyboard. More recently, pointing devices and icon-based interface techniques have been developed which permit a computer user to select tasks and to enter commands by moving a cursor on a computer display screen in response to movement of a pointing device. Pointing devices used for this task have included joysticks, trackballs and mouse controllers. One early use of a mouse as a pointing device for an icon-based computer interlace was at Xerox PARC. More recently, the mouse has become well known as a computer input device with its use on the Apple Macintosh line of computers and on the workstation computers distributed by Sun Microsystem.

However, a mouse, requires a relatively large and flat 2-dimensional surface on which to move. Typically, this surface must be unobstructed and dedicated to mouse movement and measure over 9"x9" [ . As] as a result. Other controllers, such as the trackball and joystick, are often used when flat surfaces are unavailable. as in the case of portable computers. However, trackballs and joysticks are constrained to use on a surface for practical applications.

Further, trackballs, joysticks, keys and mice are not mobile in free space nor do they provide three-dimensional output. One controller which is [mobil] *mobile* in space is taught by Ronald E. Milner in this U.S. Pat. No. 4,862,152. "Sonic Positioning Device," issued Jan. 25, 1990. This device senses the position of a controller device in three dimensions by sensing the position of an ultrasonic transmitter relative to an array of receivers. However this device is not a true pointing device as it senses position rather than a vector from the device. Since the controller must be repositioned in space, rather than simply reoriented, relatively large hand movements are required to define cursor movements. Another controller [mobil] *mobile* in free space, the Mattel Power Glove video game controller, incorporates two ultrasonic transmitters in a single controller and thus can determine a position [as web as] and define a "pointing" vector through the two transmitters. However, both of these ultrasonic controllers are based on ranging techniques and thus have range and resolution limitations. Specifically, both must be used in conjunction with an array of receivers to determine the exact position of the controllers. This results in reduced accuracy as the controller is moved to a position more distant from the receivers. Further, these controllers are only [use able] *usable* in an active volume of space defined by those receivers. Further still, both are limited to use in relatively noise-free environments.

## B. Gyroscopes:

Attitude indicators in aircraft, known as artificial horizons, use two-degree-of-freedom gyroscopes for inertia space reference and the measurement of pitch and roll relative to the gravitational vector. The gravity vector is approximated by a pendulous device (suspended weight) which indicates the apparent vertical, that is, the combined effect of gravity and acceleration. Such a device, as described in Gyroscopic Theory Design, and Instrumentation, 1980, Wrigley, Hollister and Denhard, The M.I.T. Press, Cambridge, Mass., does not correctly indicate the true direction of gravity at any instant because of vehicle accelerations. However, the average direction of the apparent vertical over a period of several minutes approximates the direction of gravity well enough to provide an attitude reference. Gyroscopes thus provide a known technique for measuring roll and pitch relative to a gravity vector. However, gyroscopes are typically heavy and expensive and have not been successfully adapted to practical use as a handheld pointing devices for cursor control in computers.

Accordingly, it is desirable to provide a hand-held computer control device which has a long range and high resolution. Further, the controller should not be constrained to use on a flat surface or within a confined space. Further, it is desirable to have a controller which responds to a vector defined by the controller, i.e. responds to "pointing" of the controller, as opposed to merely detecting the position of the controller. It is desirable to have a controller which is self-contained and not subject to interference [form] *from* outside sources of noise or subject to reduced accuracy as it is moved distant from an array of receivers.

Further, it is desirable to provide a controller that produces three-dimensional output.

## SUMMARY OF THE INVENTION

The present invention comprises a hand-held gyroscope adapted for use as a cursor control device for a computer. A motor at the core of the gyroscope is suspended by two pairs of orthogonal gimbals from a hand-held controller device which provide two-degrees-of-freedom for the gyroscope. The spin axis of the motor is norminally oriented vertically by a pendulous device. Electro-optical shaft angle encoders sense the rotation of a hand held controller device about the gyroscope as it is manipulated by a user and the resulting electrical output is converted into a format usable by a computer to control the x-y movement of a cursor on a two dimensional display screen of a computer display. The controller thus responds to angular movements of a user's hand, which permits relatively large and accurate movements of a cursor to be accurately defined without requiring correspondingly large and tiring hand movements. Further, the controller is self-contained and is thus not subject to sources of outside noise or constrained to use within any active volume. For additional ease of use, the bottom of the controller is rounded so that the controller can be reoriented or "pointed" while sitting on a surface

The resulting controller device is thus responsive to a vector

defined by the controller, i.e. the "pointing" of the controller, as opposed to merely detecting its position, and can be used either in free space or while sitting on a surface. Unlike a classical pointing device such as a stick or a flashlight, it does not require both position and vector information to "point" to another fixed position. Rather, the vector information (i.e. "pitch" and "roll") is transformed directly into the "x" and "y" coordinates of a cursor position



on a computer display. Further, by including a second gyroscope in the controller with the spin axis of the second gyroscope orthogonal to the first, "yaw" information, i.e. the angle of rotation of the controller about the spin axis of the first gyroscope, can be measured. This angle is transformed directly into the "z" information, and used to control rotation of objects or to otherwise alter the computer display, such as by making an object appear closer or further away, in response to "z" axis information. This controller is highly accurate as the result of using electro-optic shaft angle encoders, and not limited to use on a flat surface or an active volume. It allows the input of three dimensional input, in the form of "pitch," "roll," and "yaw" angles, which are transformed into "x," "y," and "z" coordinates for input to a computer for the control of the cursor location and screen display. Further, since it is self contained, it is not subject to ambient noise, such as is the case with ultrasonic controllers.

These and other advantages and features of the invention will become readily apparent to those skilled in the art after reading the following detailed description of the invention and studying the accompanying drawings.

#### BRIEF DESCRIPTION OF THE DRAWINGS

FIGS. 1 and 1A are an expanded perspective view of one embodiment of the preferred invention.

FIG. 2 is an expanded perspective view of inner gimbal 115 and bearing 122.

FIG. 3 is an illustration of the optical pattern on inner module 110, the optical pattern on gimbal frame 135, and the elements of shaft angle encoder sensing optics 165.

FIG. 4 is an illustration of a quad photodiode.

FIG. 5 is an illustration of the preferred embodiment of a gyroscopic pointing device 500 coupled to a computer and computer display 505.

FIG. 6 is a top view of an alternative embodiment of the present invention.

FIG. 7 is a top perspective view of the embodiment of FIG. 6.

FIG. 8 is a perspective illustration of a directional gyroscope used to provide three-dimensional output in the embodiment of FIGS. 6 and 7.

#### DETAILED DESCRIPTION OF THE PREFERRED EMBODIMENT

FIG. 1 is an expanded perspective view of one embodiment of the present invention. A brushless D.C. motor 105 at the core of the gyroscope spins continuously, providing the angular momentum that stabilizes the inner part of the gyroscope. Brushless D.C. Motors 105 is a motor such as used in miniature cooling fans distributed by U.S. TOYO Fan Corporation. Brushless D.C. Motors 105 is illustrated in the vertical cross section A—A of FIG. 1, and is firmly mounted to inner module 110 with motor shaft 108 aligned orthogonally with respect to the axis of rotation of inner module 110 about inner gimbals 115 and 120. Inner module 110 consists of injection molded plastic and two conductive inner gimbals gimbal 115 and gimbal 120. Inner gimbals 115 and 120 are located on and aligned with the axis of rotation of inner module 110. Further, inner gimbals 115 and 120 are electrically coupled to motor 105. The center of mass of inner module 110, which includes motor 105, is slightly displaced along the axis of rotation of motor shaft 108 below the axis of rotation of inner module 110. This results in a pendulous affect which causes motor shaft 108 to generally align with the gravity vector.

Inner gimbals 115 and 120 mechanically support inner module 110 and also provide an electrical path for the transmission of power from the gimbals to motor 105 without restricting the travel of inner module 110. Two bearings support the inner gimbals relative to gimbal frame 135. Specifically, bearing 122 is mounted within bearing alignment hole 125 of gimbal frame 135 and supports inner gimbal 115. Similarly, bearing 124 is mounted within bearing alignment hole 130 of gimbal frame 135 and supports inner gimbal 120. Gimbal frame 135 includes two conductive outer gimbals 140 and 145. Two bearings support the outer gimbals relative to shock frame 160. Specifically, bearing 146 is mounted within bearing alignment hole 150 of shock frame 160 and supports outer gimbal 140. Similarly, bearing 147 is mounted within bearing alignment hole 155 of shock frame 160 and supports outer gimbal 145. Outer gimbal 140 is electrically coupled to inner gimbal 115. Similarly, outer gimbal 145 is electrically coupled to inner gimbal 120. This completes the electrical path from the non-rotating shock frame 160 to motor 105 within inner module 110.

Shock frame 160 is mounted with shock absorbing rubber to outer housing 175, which consists of two halves. This shock mounting prevents damage to the bearings or optical sensors in the event that the gyroscope is dropped, and permits the inner assemblies to be constructed with finer tolerances than would be possible without the shock mounting. Shaft angle encoder sensing optics 165, discussed in more detail below, are mounted on shock frame 160.

Outer housing 175 is opaque so as to prevent outside light from interfering with the optical sensing system and is adapted for hand holding as described more fully below with reference to FIGS. 5 and 6.

Cabling 180 transmits power from an [interlace] interface box 185 to outer housing 175 and returns data signals from shaft angle encoder sensing optics 165. In the preferred embodiment interface box 185 translates signals from the optical sensing system 165 into serial data for an RS-232 port. Wall adapter 190 provides D.C. power for motor 105 and [shalt] shaft angle encoder sensing optics 165.

The construction details of the inner and outer gimbals [is] are shown in further detail in FIG. 2. FIG. 2 is an expanded perspective view of inner gimbal 115 and bearing 122. Inner gimbal 115 includes a circular plug 205 which fits within the inner race of bearing 122. A conductive pin 210, having a diameter smaller than that of plug 205, is mounted concentrically with plug 205 and electrically coupled to motor 205. Pin 210 is preferably made of a low-friction conductive material such as carbon-teflon and designed to protrude from the inner race of bearing 122. The diameter of pin 210 is smaller than the diameter of the inner race so as not to contact the inner race and to minimize the friction of the rotating contact. A stainless steel spring 215 is mounted to gimbal frame 135 and aligned with and in electrical contact with protruding surface 220 of pin 210.

Spring 215 is electrically coupled to a D.C. power source through outer gimbal 140. Spring 215 presses against pin 210 providing a low friction electrical connection between gimbal frame 135 and inner module 110. Inner gimbal 120 and outer gimbals 140 and 145 are constructed in an identical manner.

Inner module 110 has a hemispherical outer surface with an optical pattern which interacts with shaft angle encoder sensing optics 165 to sense the rotation of inner module 110 around the axis of rotation through gimbals 115 and 120. This optical pattern is illustrated in FIG. 3. The optical pattern on inner module 110 is constructed by first painting the

5

hemispherical surface with a highly reflective aluminum flaked paint and then machining grooves of 0.015 inch depth and width along "lines of longitude" from gimbal 115 towards gimbal 120 along the surface. The grooves are machined to within 30 degrees of each inner gimbal and are 0.015 inches apart at 30 degrees from each gimbal. The pattern causes the spacing between the groove centerlines to widen to approximately 0.04 inches at the middle ("equator") of inner module 110. Inner module 110 is molded from a non-reflective black plastic. Thus the grooved portions of inner module 110, where the reflective paint has been machined off, are non-reflective. This provides a precise optical pattern on inner module 110 having a relatively high contrast ratio.

[And] A second optical pattern is machined into gimbal frame 135 along a cylindrical section 170 of gimbal frame 135. This pattern interacts with [shaft] shaft angle encoder sensing optics 165 for sensing rotation of gimbal frame 135 around its axis of rotation through gimbals 140 and 145. This cylindrical section is geometrically centered about the axis of rotation of gimbal frame 135, which passes through gimbals 140 and 145. As with the optical pattern on the inner module 110, the optical pattern on gimbal frame 135 is constructed by applying reflective paint to cylindrical section 170 and then machining grooves of 0.015 inch depth and width on the surface of the cylinder.

These grooves are machined along lines parallel to the axis of rotation of gimbal frame 135 and evenly spaced so that the light and dark strips are of equal width. Cylindrical section 170 is displaced slightly from the center of gimbal frame 135 so as not to interfere with the interaction of shaft angle encoder sensing optics 165 and the optical pattern on inner module 110. Specifically, the closest edge of cylindrical section 170 is spaced approximately 0.15 inches away from the "equator" of frame 170 passing through inner gimbals 115 and 120.

Shaft angle encoder sensing optics 165 interact with the optical pattern on inner module 110 so as to determine the rotation of the inner module 110 about its axis of rotation. More specifically, shaft angle encoder sensing optic 165 include sources for illuminating the patterns, lenses for focusing images of the patterns, and photodetectors for [detect a] detecting dark or light areas. Referring to FIG. 3, a first LED 305 is mounted to shock frame 160 at an angle of 30 degrees from vertical in a plane parallel to the axis through gimbals 140 and 145 so as to floodlight an area 310 of the optical pattern on inner module 110. This area is centered on the "equator" of frame 135 so as to provide maximum range of detectable movement in both directions. Lens 315 and mirror 320 focus and reflect the image of the illuminated optical pattern onto quad photodiode 325. Lens 315 is an injection molded lens of approximately 1/8 inch in diameter having a focal length of approximately 0.2 inches.

Quad photodiode 325 comprises four photodiodes, 402, 404, 406 and 408, located in a row as illustrated in FIG. 4. The sides of quad photodiode 325 are aligned with the edges of the projected image of the optical pattern on inner module 110. One period of the projected image of the optical pattern on inner module 110 (one light and one dark bar) nominally covers the quad photodiode 325, which comprise four photodiodes centered 0.02 inches apart. Photodiodes 402 and 406 are [counted] coupled to comparator [420] 410. Photodiodes 404 and 408 are coupled to comparator [410] 420. The output V1 of comparator 410 is thus in phase quadrature with the output V2 of comparator 420. These outputs are then detected by conventional means to determine the rotation of the inner module. An example of phase quadrature

6

resolution is provided in U.S. Pat. No. 4,346,989 titled Surveying Instrument, issued to Alfred F. [Gori] Gort and Charles E. Moore Aug. 31, 1982 and assigned to the Hewlett-Packard Company. A prototype of this embodiment of the present invention results in a resolution of approximately 100 counts per inch.

Shaft angle encoder sensing optics 165 also interacts with the optical pattern on gimbal frame 160 so as to determine the rotation of gimbal frame 135 about its axis of rotation. More specifically, a second sensing system, similar to the one described but oriented 90 degrees with respect to the first, is positioned on frame 160 so as to interact with the optical pattern on frame 135 and to detect rotation of frame 135 about its axis of rotation. Referring again to FIG. 3, a second LED 330 is mounted to shock frame 160 at an angle of 30 degrees from vertical in a plane parallel to the axis through gimbals 115 and 120 in alignment with cylindrical section 170 so as to floodlight an area 335 of the optical pattern on cylindrical section 170. Lens 340 and mirror 320 focus and reflect the image of the illuminated optical pattern onto quad photodiode 345. Lens 340 is an injection molded lens of approximately 1/8 inch in diameter having a focal length of approximately 0.2 inches.

Quad photodiode 345 comprises four photodiodes located in a row and is identical in construction to quad photodiode 325 illustrated in FIG. 4. The sides of quad photodiode 345 are aligned with the edges of the projected image of the optical pattern on gimbal frame 135. FIG. 5 is an illustration of the preferred embodiment of a gyroscopic pointing device 500 coupled to a computer 502 and computer display 505. Computer 502 is adapted so that changing the pitch of controller 500 relative to the gravity vector [charges] changes the vertical position of cursor 510 on computer display 505. That is, rotating the controller forward ("pitch") causes the cursor to drop on a vertical computer screen, *rotating it back causes the cursor to drop on a vertical computer screen*, rotating it back causes the cursor to rise, as if the controller was pointing at the cursor. Similarly, rotating the controller from side to side ("roll") changes the horizontal position of cursor 510 on computer display 505. That is, rotating the controller left causes the cursor to move left on a vertical computer screen, rotating it right causes the cursor to move to the right, again, as [it] if the controller was pointing at the cursor. Controller 500 further includes a thumb operated push button 520 and has a rounded hemispherically shaped bottom portion 525 adapted for smoothly rocking on a flat surface when the pitch and roll of controller 500 is varied while resting on a flat surface. This can be a two position switch, where initial pressure on the switch activates the controller and causes the cursor to move in response to the controller, and a second position of the switch results in a "pick" or "select" signal being transmitted to the computer.

FIG. 6 is a top view of an alternative embodiment of the present invention. FIG. 7 is a top perspective view of the same embodiment. Specifically, FIGS. 6 and 7 illustrate a controller shaped so as to be hand held in a manner such that the palm will be facing down while controller 610 is resting on a flat surface. The under side of controller 610 is rounded to facilitate changes of its orientation with respect to vertical. A palm button 620 is actuated when the controller is grasped, thus permitting the controller to be deactivated, moved or reoriented, then reactivated. A pick button 630 is located for selective activation by a [users lingers] user's fingers in a manner similar to the use of a pick button on a mouse controller.

The embodiment of FIGS. 6 and 7 includes a first gyroscope as discussed with regards to FIGS. 1-4 for the mea-

surement of pitch and roll. Further, it includes a second gyroscope, as illustrated in FIG. 8, for measurement of yaw about the vertical axis. Specifically, a rotating gyroscopic element 810 is mounted in a two-degree-of freedom gimbal system with its spin axis 820 in a horizontal direction. In the preferred embodiment a mass gives the gyroscope a pendulosity at right angles to spin axis 820. More specifically, gyroscope 810 is mounted to inner frame 815. Inner frame 815 is mounted to gimbal frame 825 by inner gimbals 845. Gimbal frame 825 is mounted to an outer housing 860 by gimbal 850. A shaft angle encoder 870 is coupled to detect the rotation of gimbal frame 825 relative to outer housing 860. Oscillations are damped out by applying an antipendulous torque caused by liquid flow of a viscous fluid through a constriction in a tube, as in damper 840. Computer 502 is further adapted to convert the angle measured by shaft angle encoder 870. This conversion could be to rotation of the cursor or a cursor-selected object or for providing a "z" input for a three dimensional display or a two-dimensional display simulating a three dimensional view.

While the invention has been particularly taught and described with reference to the preferred embodiment, those versed in the art [rill] will appreciate that minor modifications in form and detail may be made without departing from the spirit and scope of the invention. For instance, although the illustrated embodiment teaches one system of shaft angle encoders, many alternative systems could be used for detecting the orientation of the gyroscopic controller. Further, while the preferred embodiment [leaches] teaches a vertically oriented gyroscope and detection of two angles from vertical such as in an artificial horizon instrument. Other gyroscopic orientations, such as those used for directional gyroscopes, could be substituted. Further, while the present invention teaches the detection of two angles from a vertically oriented gyroscope and one angle from a horizontally oriented gyroscope, two angles could be detected from the horizontal gyroscope, and one from the vertical gyroscope. Further, many techniques equivalent [techniques] to the pendulous technique are known for orienting gyroscopes. Accordingly, all such modifications are embodied within the scope of this patent [as] and properly come within [our] my contribution to the art [and] as are particularly pointed out by the following claims.

I claim:

1. A method for [moving] effecting movements of a [displayed] displayable object on [an interactive] a computer graphic display having vertical and horizontal Cartesian coordinate axes in response to one of pitch and yaw rotations of an input device, the method comprising: [the steps of:]

[detecting the pitch or yaw rotation of the device;]  
sensing an inertial response to [provide] pitch or yaw rotation of the input device to produce a signal [indicative of] proportional to the at least one of the pitch and yaw rotations of the input device; and

[in response to the signal indicating the detected pitch or yaw movement of the input device,] moving the [displayed] displayable object a distance in a plane defined by the vertical and horizontal axes on the computer graphic display[, the displayed object being moved] in substantially continuous proportionality to the signal and translationally along one of the vertical and horizontal axes in substantially a single direction for each direction in which the input device is rotated.

2. [A] The method [for effecting translational movements of a displayed object on an interactive computer graphic display as in] according to claim 1 further comprising: [the steps of:]

selectively inhibiting the input device from producing a signal to permit reorientation of the input device without substantially proportional translational movement of the displayed object on the computer graphic display; and

selectively enabling the input device for producing the signal in response to said one of pitch and yaw rotations of the input device.

3. A method for [providing a signal to effect] effecting translational movements of a [displayed] displayable object on [an interactive] a computer graphic display using an input device including an inertial gyroscopic element that is manually movable in free space, the method comprising: [the steps of:]

supporting the inertial gyroscopic element with respect to the input device;

actuating the gyroscopic element to exhibit inertia relative to an inertial axis;

detecting rotational movement of the input device relative to the inertial axis of the gyroscopic element; and

[providing] producing a signal [responsive] substantially proportional to the rotation of the input device relative to the inertial axis for effecting translational movements of the [displayed] displayable object on the computer graphic display in substantially continuous proportionality to the signal and in a single direction for each direction in which the input device is rotated.

4. A method for [providing a signal to effect] effecting translational movements of a [displayed] displayable object on [an interactive] a computer graphic display using an inertial input device that is manually movable in free space, the method comprising: [the steps of:]

detecting[, by inertial means,] rotational movement of the input device about one axis; and

[providing] producing a first signal [responsive] substantially proportional to the rotation of the input device about the one axis for effecting translational movements of the [displayed] displayable object on the computer graphic display in substantially continuous proportionality to the first signal and in a single direction for each direction in which the input device is rotated.

5. [A] The method according to claim 4 for [providing signals to effect] effecting the translational movements on [an interactive] the computer graphic display along at least one of first and second coordinate axes[, using the inertial input device, the method further comprising: [the steps of:]

detecting[, by inertial means,] rotational movement of the input device about a second axis not parallel to the one axis;

[providing] producing a second signal [responsive] substantially proportional to the rotation of the input device about the second axis[; and] for effecting translational movements [on the display] of the displayable object along a first coordinate axis of the computer graphic display in [response] substantially continuous proportionality to the first signal and in a single direction for each direction in which the input device is rotated about the one axis, or along a second coordinate axis of the computer graphic display in [response] substantially continuous proportionality to the second signal and in a single direction for each direction in which the input device is rotated about the second axis.

6. [A graphical] An input device for providing a signal to effect translational movements of a [displayed] displayable object on [an interactive] a computer graphic display, comprising:

a *hand-held* housing adapted for manual movement in free space; and

an inertial gyroscopic element mounted with respect to said housing, [for providing a signal, in response] *and responsive* to rotation of the housing about an axis, to effect] *for producing a signal substantially proportional to said rotation for effecting* translational movements of the [displayed] *displayable* object on [an interactive] *the* computer graphic display in substantially *continuous proportionality to the signal and in a* single direction for each direction in which the [device] *housing* is rotated.

7. [A graphical] *The* input device [for providing a signal to effect translational movements of a displayed object on an interactive computer graphic display as in] *according to* claim 6[,] wherein the gyroscopic element comprises an angular position gyroscope.

8. [A graphical] *The* input device [for providing a signal to effect translational movement of a displayed object on an interactive computer graphic display as in] *according to* claim 7[,] wherein the angular position gyroscope comprises:

an inertial gyroscopic element disposed to spin about a spin axis;

a gimbal supporting the gyroscopic element with respect to the housing; and

a sensor disposed with respect to the gimbal and the housing for producing said signal in response to rotation of the housing relative to the spin axis.

9. A graphical input device for providing a signal to effect the translational movement of a cursor on an interactive computer graphic display comprising:

a housing adapted for manual movement in free space;

an inertial gyroscopic element disposed to spin about one spin axis;

a gimbal supporting the gyroscopic element with respect to the housing; and

a sensor disposed with respect to the gimbal and the housing for producing a signal, in response to rotation of the housing relative to one spin axis, to effect translational movement of the cursor in substantially a single direction for each direction in which the housing is rotated.

10. A graphical input device for providing a signal to effect the translational movement of a cursor on an interactive computer graphic display as in claim 9 further comprising a manually operable switch mounted with respect to the housing and operatively connected for selecting inhibiting the graphical input device from producing a signal to permit reorientation of the graphical input device without translational movement of the cursor in response to said signal, and for selectively enabling the graphical input device for producing said signal in response to rotational movement of the housing relative to the spin axis of the gyroscopic element.

11. A graphical input device for providing signals to effect translational movement of a cursor on an interactive computer graphic display as in claim 10 wherein the signal is produced in response to one of pitch and yaw rotational movement of the housing for effecting the translational movement of the cursor along one of vertical and horizontal Cartesian coordinate axes of the display in response to the signal.

12. An interactive computer graphic display system comprising a graphical input device as in claim 11 and further comprising a circuit coupled to the display for effecting the translational movement of the cursor along one of the horizontal and vertical Cartesian coordinate axes of the display in response to the signal.

13. A method for controlling translational movements of a [displayed] *displayable* object on [an interactive] *a* computer graphic display having vertical and horizontal Cartesian coordinate axes in response to one of pitch and yaw rotations of an input device, the method comprising: [the steps of:]

detecting the pitch or yaw rotation of the *input* device;

sensing an inertial response to [provide] *produce* a signal [indicative of] *substantially proportional to* at least one of the pitch and yaw rotations of the *input* device; and

in response to [detecting pitch or yaw movement of the input device,] *the signal*, moving the [displayed] *displayable* object a *substantially continuously proportional* distance in a plane defined by the vertical and horizontal axes on the computer graphic display without rotating the [displayed] *displayable* object.

14. [A graphical] *An* input device for providing a signal to manipulate translational movements of a [displayed] *displayable* object on [an] *a* computer graphic display, comprising:

a *hand-held* housing adapted for manual movement in free space; and

an inertial gyroscopic element mounted with respect to said housing[, for providing a signal, in response] *and responsive* to rotation of the housing about an axis[, to manipulate] *for producing a signal substantially proportional to said rotation for manipulating* translational movements of the [displayed] *displayable* object on [an interactive] *the* computer graphic display in *substantially continuous proportionality to the signal* without causing the [displayed] *displayable* object to be rotated.

15. A method for [providing] *producing* a signal to control translational movements of a [displayed] *displayable* object on [an interactive] *a* computer graphic display using an input device including an inertial gyroscopic element that is manually movable in free space, the method comprising: [the steps of:]

supporting the inertial gyroscopic element with respect to the *input* device;

actuating the gyroscopic element to exhibit inertia relative to an inertial axis;

detecting rotational movement of the *input* device relative to the inertial axis of the gyroscopic element; and

[providing] *producing* a signal [responsive] *substantially proportional to* the rotation of the *input* device relative to the inertial axis for controlling translational movements of the [displayed] *displayable* object in *substantially continuous proportionality to the signal* without causing the [displayed] *displayable* object to be rotated.

16. *An interactive computer graphic display system comprising an input device according to claim 6 and further comprising a circuit coupled to the computer graphic display for effecting the translational movement of a displayable object along one of horizontal and vertical Cartesian coordinate axes of the computer graphic display in substantially continuous proportionality to the signal.*

17. *A method for effecting movements of a displayable object on a graphic display having vertical and horizontal Cartesian coordinate axes in response to one of pitch and yaw rotations of an input device, the method comprising:*

*sensing gravitational orientation;*

*sensing an inertial response to pitch or yaw rotation of the input device relative to the gravitational orientation to produce a signal indicative of at least one of the pitch and yaw rotations of the input device relative to the gravitational orientation; and*

*and*

11

moving the displayable object a distance in a plane defined by the vertical and horizontal axes on the computer graphic display translationally along one of the vertical and horizontal axes in substantially a single direction for each direction in which the input device is rotated.

18. The method according to claim 17, further comprising:

selectively inhibiting the input device from producing the signal to permit reorientation of the input device without translational movement of the displayed object on the computer graphic display; and

selectively enabling the input device for producing the signal in response to said one of pitch or yaw rotations of the input device relative to the gravitational orientation.

19. A method for effecting movements of a displayable object on a graphic display having vertical and horizontal Cartesian coordinate axes in response to one of pitch and yaw rotations of an input device including an inertial element, the method comprising:

sensing gravitational orientation;

sensing an inertial response to pitch or yaw rotation of the inertial element relative to the gravitational orientation to produce a signal indicative of at least one of the pitch and yaw rotations of the device relative to the gravitational orientation; and

moving the displayable object a distance in a plane defined by the vertical and horizontal axes on the computer graphic display translationally along one of the vertical and horizontal axes in substantially a single direction for each direction in which the input device is rotated.

20. The method according to claim 19, further comprising:

selectively inhibiting the inertial element from producing the signal to permit reorientation of the input device without translational movement of the displayed object on the computer graphic display; and

selectively enabling the inertial element for producing the signal in response to said one of pitch or yaw rotations of the input device relative to the gravitational orientation.

21. A method for effecting translational movements of a displayable object on a computer graphic display using an input device including an inertial gyroscopic element that is manually movable in free space, the method comprising:

supporting the inertial gyroscopic element with respect to the input device; actuating the gyroscopic element to exhibit inertia relative to an inertial axis;

sensing gravitational orientation;

detecting rotational movement of the input device about the inertial axis of the gyroscopic element relative to the gravitational orientation; and

producing a signal responsive to the rotation of the input device about the inertial axis relative to the gravitational orientation for effecting translational movements of the displayable object on the computer graphic display in substantially a single direction for each direction in which the input device is rotated.

22. A method for effecting translational movements of a displayable object on a computer graphic display using an inertial input device that is manually movable in free space, the method comprising:

12

sensing gravitational orientation;

detecting rotational movement of the input device about one axis relative to the gravitational orientation; and

producing a first signal substantially proportional to the rotation of the input device about the one axis for effecting translational movements of the displayable object on the computer graphic display in substantially continuous proportionality to the first signal and in a single direction for each direction in which the input device is rotated.

23. The method according to claim 22 for effecting the translational movements on the computer graphic display along at least one of first and second coordinate axes using the inertial input device, the method further comprising:

detecting rotational movement of the input device about a second axis not parallel to the one axis and relative to the gravitational orientation;

producing a second signal responsive to the rotation of the input device about the second axis for effecting translational movements of the displayable object along a first coordinate axis of the computer graphic display in substantially continuous proportionality to the first signal and in a single direction for each direction in which the input device is rotated about the one axis, or along a second coordinate axis of the computer graphic display in response to the second signal and in a single direction for each direction in which the input device is rotated about the second axis.

24. An input device for producing a signal to effect translational movements of a displayable object on a computer graphic display, comprising:

a hand-held housing adapted for manual movement in free space;

sensing apparatus in the housing to detect gravitational orientation; and

an inertial gyroscopic element mounted with respect to said housing and responsive to rotation of the housing about an axis relative to the gravitational orientation to produce a signal indicative of said rotation for effecting translational movements of the displayable object on the computer graphic display in substantially a single direction for each direction in which the housing is rotated.

25. An input device according to claim 24, wherein the sensing apparatus detects substantially vertical gravitational orientation independent of the orientation of the housing in free space.

26. The input device according to claim 25, wherein the sensing apparatus comprises:

an inertial gyroscopic element disposed to spin about a spin axis;

a gimbal supporting the gyroscopic element with respect to the housing and including a center of mass eccentric the spin axis; and

a sensor communicating with the gimbal for producing an output indicative of the gravitational orientation.

27. An input device for producing a signal to effect translational movement of a displayable object on a graphic display, the input device comprising:

a hand-held housing adapted for manual movement in free space;

an inertial gyroscopic element disposed to spin about one spin axis;

a gimbal supporting the gyroscopic element with respect to the housing and including a center of mass eccentric the spin axis;

13

a first sensor disposed with respect to the gimbal and the housing and responsive to rotation of the housing relative to one spin axis for producing a signal substantially proportional to said rotation for effecting translational movement of the displayable object in substantially continuous proportionality to the signal and in a single direction for each direction in which the housing is rotated; and

a second sensor in communication with the gimbal for producing an output indicative of gravitational orientation, independent of the orientation of the housing in free space.

28. An interactive computer graphic display system comprising an input device as in claim 24 and further comprising a circuit coupled to the display for effecting translational movement of the displayable object along one of horizontal and vertical Cartesian coordinate axes of the computer graphic display in response to the rotation of the housing relative to the gravitational orientation.

29. An input device for manipulating translational movements of a displayable object on a computer graphic display, comprising:

a hand-held housing adapted for manual movement in free space;

sensing apparatus in the housing to detect gravitational orientation; and

an inertial element mounted with respect to said housing and responsive to rotation of the housing about an axis relative to gravitational orientation for producing a signal indicative of said rotation for manipulating translational movements of the displayable object on the computer graphic display without causing the displayable object to be rotated.

30. A method for producing a signal to control translational movements of a displayable object on a computer display using an input device including an inertial element that is manually movable in free space, the method comprising:

supporting the inertial element with respect to the input device;

sensing gravitational orientation of the input device in free space;

sensing inertia of the input device relative to the sensed gravitational orientation;

detecting rotational movement of the input device with respect to an inertial axis of the inertial element relative to the gravitational orientation; and

producing a signal substantially proportional to the rotation of the input device about the inertial axis relative to the gravitational orientation for controlling translational movements of the displayable object in response to the signal without causing the displayable object to be rotated.

31. The method according to claim 5 further comprising: selectively inhibiting producing at least one of the first and second signals to permit reorientation of the device without translational movement of the displayable object on the computer display; and

selectively enabling producing the at least one of the first and second signals in response to rotational movement of the input device about the corresponding one and second axes.

32. The input device according to claim 6 comprising:

a switch mounted on the housing for manual activation to one operating state for selectively inhibiting producing said signal, and for actuation to another operating

14

state for enabling producing said signal in response to said rotation of the housing.

33. An input device for producing a signal to manipulate translational movements of a displayable object on a computer graphic display, comprising:

a hand-held housing adapted for manual movement in free space;

an inertial element mounted with respect to the said housing and responsive to rotation of the housing with respect to an inertial axis of the inertial element for producing a signal indicative of said rotation for manipulating translational movements of the displayable object on the computer graphic display; and

a switch mounted on the housing for manual actuation to one operating state for selectively inhibiting producing said signal, and for actuation to another operating state for enabling producing said signal in response to said rotation.

34. The method according to claim 23 further comprising:

selectively inhibiting producing at least one of the first and second signals to permit reorientation of the input device without translational movement of the displayable object on the computer graphic display; and

selectively enabling producing at least the one of the first and second signals in response to said rotation of the input device about the corresponding one and second axes.

35. The input device according to claim 24 comprising:

a switch mounted on said housing for manual actuation to one operating state for selectively inhibiting producing said signal, and for actuation to another operating state for enabling producing said signal in response to said rotation of the housing.

36. The input device according to claim 29 comprising:

a switch mounted on said housing for manual actuation to one operating state for selectively inhibiting producing said signal and for actuation to another operating state for enabling producing said signal in response to said rotation of the housing.

37. The method according to claim 30, further comprising:

selectively inhibiting producing said signal to permit reorientation of the input device without translational movement of the displayable object on the computer graphic display; and

selectively enabling producing said signal in response to said rotation of the input device.

38. An input device for producing a signal to effect translational movements of a displayable object on a computer graphic display, comprising:

an inertial gyroscopic means adapted for manual movement in free space for producing a signal substantially proportional to rotation of the housing about an axis to effect translational movements of the displayable object on the computer graphic display in substantially continuous proportionality to the signal and in a single direction for each direction in which the inertial gyroscopic means is rotated.

39. The input device according to claim 38 wherein the inertial gyroscopic means comprises an angular position gyroscope.

40. The input device according to claim 38 further comprising:

switch means mounted with respect to the inertial gyroscopic means for selectively inhibiting producing said

15

signal to permit reorientation of the input device without translational movement of the displayable object in response to said signal and for selectively enabling the input device to produce said signal.

41. An interactive computer graphic display system comprising an input device as in claim 38 and further comprising circuit means for effecting translational movement of the displayable object along one of horizontal and vertical Cartesian coordinate axes of the computer graphic display in substantially continuous proportionality to the signal.

42. An input device according to claim 38 comprising:  
sensing means for detecting gravitational orientation;  
and  
said inertial gyroscopic means produces said signal indicative of said rotation relative to the gravitational orientation.

43. An interactive computer graphic display system comprising an input device as in claim 42 and further comprising circuit means for effecting translational movement of the displayable object along one of horizontal and vertical Cartesian coordinate axes of the computer graphic display in response to the rotation of the housing relative to the gravitational orientation.

44. An input device for manipulating translational movements of a displayable object on a computer graphic display, comprising:

hand-held housing means adapted for manual movement in free space;  
sensing means in the housing means for detecting gravitational orientation; and

16

*inertial means mounted with respect to said housing means and responsive to rotation of the housing means about an axis relative to gravitational orientation for producing a signal indicative of said rotation for manipulating translational movements of the displayable object on the computer graphic display without causing the displayable object to be rotated.*

45. The input device according to claim 38 comprising:  
switch means with the inertial gyroscopic means for manual activation to one operating state for selectively inhibiting producing said signal, and for actuation to another operating state for enabling producing said signal in response to said rotation of the housing.

46. The input device according to claim 42 comprising:  
switch means mounted with said sensing means and said inertial gyroscopic means for manual actuation to one operating state for selectively inhibiting producing said signal, and for actuation to another operating state for enabling producing said signal in response to said rotation.

47. The input device according to claim 44 comprising:  
switch means on said housing means for manual actuation to one operating state for selectively inhibiting producing said signal, and for actuation to another operating state for enabling producing said signal in response to said rotation of said housing means.

\* \* \* \* \*