



US00RE41508E

(19) **United States**
(12) **Reissued Patent**
Treece

(10) **Patent Number:** **US RE41,508 E**
(45) **Date of Reissued Patent:** ***Aug. 17, 2010**

(54) **UNIVERSAL CEMENTING PLUG**
(75) Inventor: **Harold O. Treece**, Duncan, OK (US)
(73) Assignee: **Halliburton Energy Services, Inc.**,
Duncan, OK (US)

EP 0498990 8/1992
EP 0697496 2/1996
EP 0 697 496 A2 * 2/1996
EP 0774564 5/1997
EP 0 774 564 A2 * 5/1997
EP 0 869 257 A2 * 10/1998
EP 0869257 10/1998
FR 2 663 678 A1 * 12/1991

(*) Notice: This patent is subject to a terminal disclaimer.

(21) Appl. No.: **10/930,058**
(22) Filed: **Aug. 30, 2004**

OTHER PUBLICATIONS
Halliburton Services Sales & Service Catalog No. 44, pp. 26–30 and 48–52 (1990).

(Continued)

Related U.S. Patent Documents

Reissue of:
(64) Patent No.: **6,196,311**
Issued: **Mar. 6, 2001**
Appl. No.: **09/175,664**
Filed: **Oct. 20, 1998**

Primary Examiner—Christopher J. Novosad
(74) Attorney, Agent, or Firm—Craig W. Roddy; Haynes and Boone, LLP

U.S. Applications:

(63) Continuation of application No. 09/970,432, filed on Oct. 3, 2001, now Pat. No. Re. 41,117.

(51) **Int. Cl.**
E21B 33/16 (2006.01)

(52) **U.S. Cl.** **166/192**

(58) **Field of Classification Search** 166/192–194,
166/289–291, 153–155, 317
See application file for complete search history.

(57) **ABSTRACT**

A cementing plug having a universal construction and improved wiping and extended wear characteristics. The cementing plug has a plug subassembly with a body member and an elastomeric jacket on the body member. The body member defines a central opening therethrough with a shoulder therein. To configure the plug as a bottom cementing plug, a shearable insert is positioned on the shoulder, and to configure the plug as a top cementing plug, a non-shearable insert is positioned on the shoulder. The shearable insert is one of a plurality of such inserts designed to shear at correspondingly different shear pressures. In a first embodiment, the shearable insert is a substantially flat disk having a uniform thickness, and in a second embodiment, the shearable insert has an outer ring portion and a relatively thin inner domed portion. Thus, a bottom plug may be pumped down a well casing with cement and a top plug thereabove so that when the bottom plug lands at the bottom of the casing, the shearable insert will shear at the predetermined pressure. The jacket has one or more wiper cups which have a conical surface extending at an acute angle with respect to a longitudinal axis of the plug, thereby providing a substantially large contact area in the well casing to improve wiping efficiency and extend life.

(56) **References Cited**

U.S. PATENT DOCUMENTS

3,605,896 A 9/1971 Perkins

(Continued)

FOREIGN PATENT DOCUMENTS

EP 0 371 576 A1 * 6/1990
EP 0371576 6/1990
EP 2663678 12/1991
EP 0 498 990 A1 * 8/1992

23 Claims, 2 Drawing Sheets

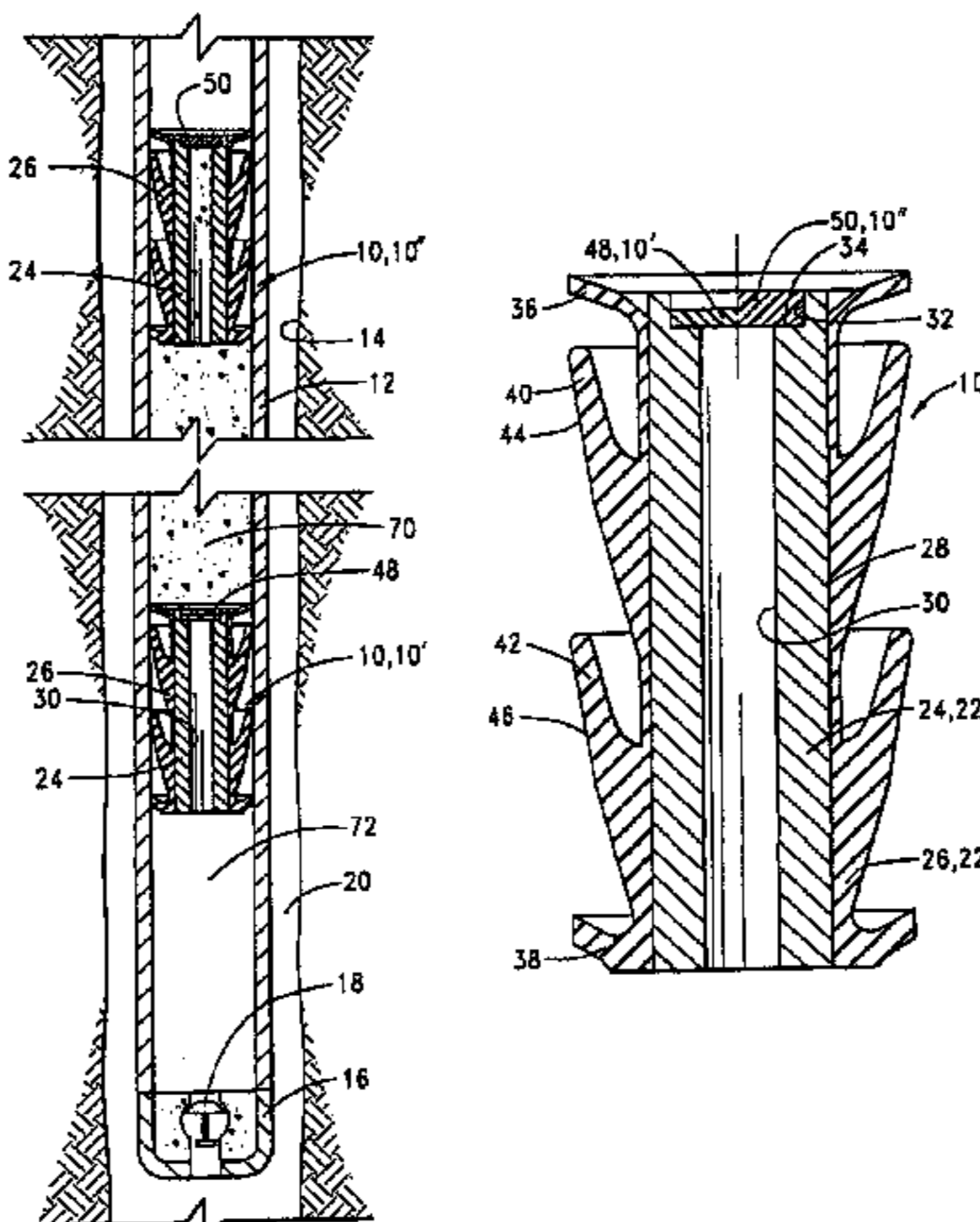

U.S. PATENT DOCUMENTS

3,616,850	A	11/1971	Scott	
3,630,281	A	* 12/1971	Fast et al.	166/290
3,768,556	A	10/1973	Baker	
3,768,562	A	10/1973	Baker	
3,796,260	A	3/1974	Bradley	
3,948,322	A	4/1976	Baker	
4,246,967	A	1/1981	Harris	
4,246,968	A	1/1981	Jessup et al.	
4,624,312	A	11/1986	McMullin	
4,706,747	A	11/1987	Schneider	
4,756,365	A	7/1988	Schneider	
4,836,279	A	6/1989	Freeman	
4,858,687	A	8/1989	Watson et al.	
4,921,046	A	5/1990	Caskey	
4,934,452	A	6/1990	Bradley	
5,095,980	A	3/1992	Watson	
5,117,910	A	6/1992	Brandell et al.	
5,226,561	A	* 7/1993	Hamilton et al.	222/5
5,242,018	A	9/1993	LaFleur	
5,311,940	A	5/1994	LaFleur	
5,361,835	A	11/1994	LaFleur	
5,433,270	A	7/1995	LaFleur	
5,435,386	A	7/1995	LaFleur	
5,437,330	A	8/1995	Gambertoglio	
5,533,570	A	7/1996	Streich et al.	
5,722,491	A	3/1998	Sullaway et al.	
5,813,457	A	9/1998	Giroux et al.	
6,419,015	B1	7/2002	Budde et al.	

OTHER PUBLICATIONS

Halliburton Energy Services Drawing No. 402.15013 (Aug. 1993).

Office Action mailed Mar. 1, 2002, by the U.S. Patent and Trademark Office in connection with U.S. Appl. No. 09/970, 432.

Office Action mailed Sep. 16, 2002, by the U.S. Patent and Trademark Office in connection with U.S. Appl. No. 09/970, 432.

Office Action mailed Nov. 18, 2002, by the U.S. Patent and Trademark Office in connection with U.S. Appl. No. 09/970, 432.

Office Action mailed Apr. 16, 2003, by the U.S. Patent and Trademark Office in connection with U.S. Appl. No. 09/970, 432.

Office Action mailed Jun. 30, 2006, by the U.S. Patent and Trademark Office in connection with U.S. Appl. No. 09/970, 432.

Office Action mailed May 30, 2008, by the U.S. Patent and Trademark Office in connection with U.S. Appl. No. 09/970, 432.

Office Action mailed Sep. 19, 2008, by the U.S. Patent and Trademark Office in connection with U.S. Appl. No. 09/970, 432.

Office Action mailed Mar. 17, 2006, by the U.S. Patent and Trademark Office in connection with U.S. Appl. No. 11,267, 892.

Office Action mailed Aug. 14, 2006, by the U.S. Patent and Trademark Office in connection with U.S. Appl. No. 11,267, 892.

Office Action mailed Dec. 9, 2008, by the USPTO, in connection with U.S. Appl. No. 11/267,892.

* cited by examiner

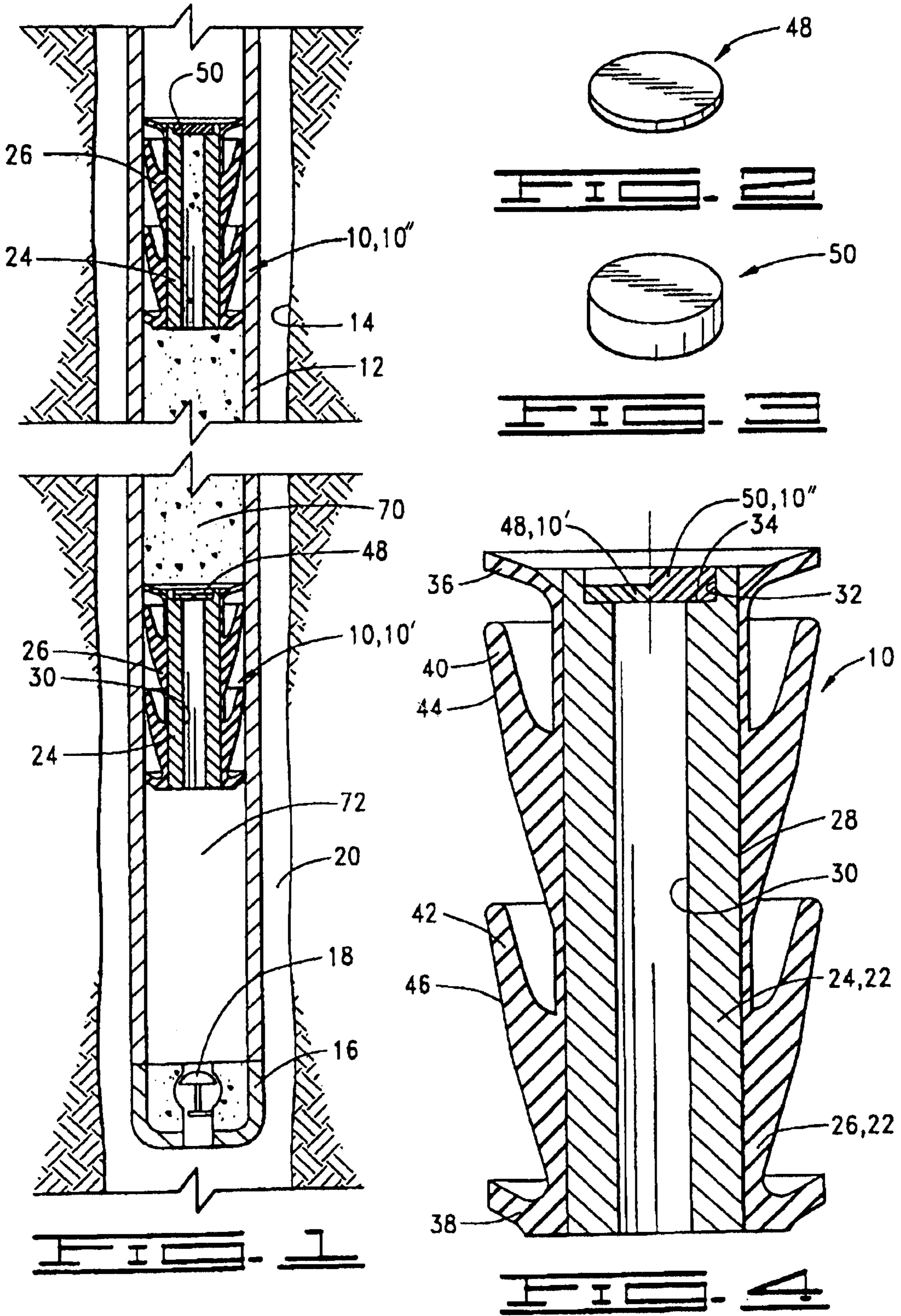

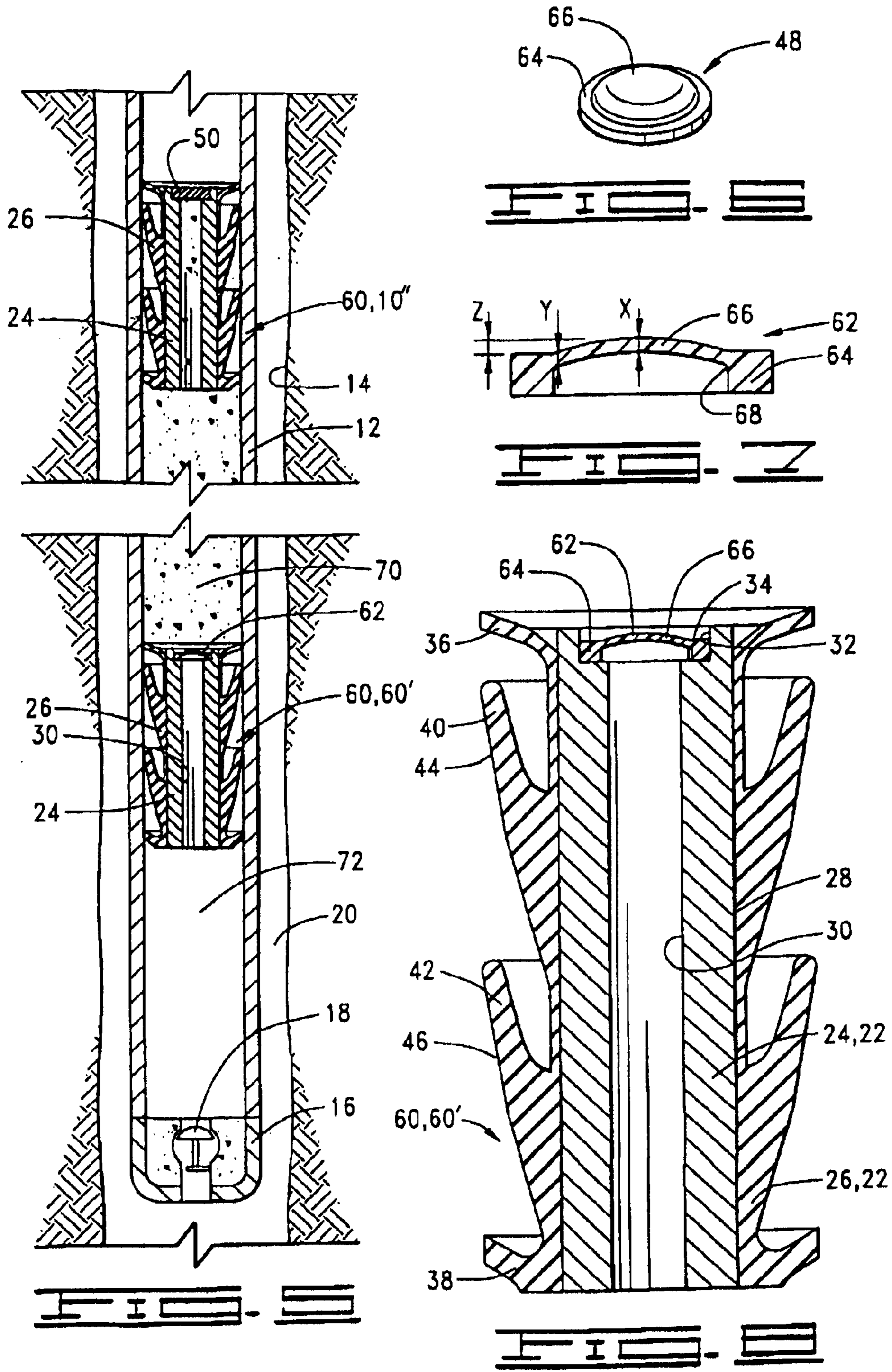

UNIVERSAL CEMENTING PLUG

Matter enclosed in heavy brackets [] appears in the original patent but forms no part of this reissue specification; matter printed in italics indicates the additions made by reissue.

CROSS REFERENCE

This application is a continuation of U.S. patent application Ser. No. 09/970,432 filed Oct. 3, 2001 which is a reissue of U.S. patent application Ser. No. 09/175,664 filed Oct. 20, 1998, now U.S. Pat. No. 6,196,311 which issued on Mar. 6, 2001. This application is related to U.S. patent application Ser. No. 10/307,113 filed Apr. 10, 2003 (now abandoned) and U.S. patent application Ser. No. 11/267,892 filed Nov. 4, 2005 both of which are divisional of U.S. patent application Ser. No. 09/970,432 filed Oct. 3, 2001.

BACKGROUND OF THE INVENTION

1. Field of the Invention

This invention relates to cementing plugs for use in cementing casing in a well, and more particularly, to a universal cementing plug having improved wiping and extended wear and which includes a plurality of interchangeable inserts so that the plug may be selectively used as a top or a bottom plug.

2. Description of the Prior Art

In the process of preparing a well for testing and/or production, a casing is positioned in the well and cemented in place. Typically, at the beginning of the cementing job in rotary-drilled wells, the casing and the wellbore are usually filled with drilling mud. In many areas, to reduce contamination on the interface between the mud and cement a bottom plug is released from a plug container and pumped ahead of the cement slurry. Such plugs have wipers of an elastomeric material thereon to wipe the casing of any accumulated mud film so that the mud is pushed ahead of the bottom plug.

When the bottom plug reaches floating equipment such as a float collar or float shoe at the bottom of the casing string, a fluid pressure differential created across the plug ruptures a rubber diaphragm at the top of the plug and allows the cement slurry to proceed down the casing through the plug and floating equipment and then up an annulus space defined between the casing and the wellbore.

When all of the cement has been mixed and pumped into the casing string, a top cementing plug is released from the plug container. The top plug also has wipers of elastomeric material thereon. The function of the top plug is to follow the cement and wipe any accumulated cement film from the inside of the casing. The top plug is also designed to reduce the possibility of any contamination or channeling of the cement slurry with the drilling mud that is used to displace the cement column down the casing and into the annular space between the casing the wellbore. The top cementing plug is typically solid in construction, and the design is such that when it reaches the bottom cementing plug at the float collar or float shoe, the top cementing plug causes a shutoff of fluids being pumped into the casing. This causes a normal pressure rise at the surface and notifies the operator that the cementing job is complete.

The landing of the top plug lessens the possibility of any further displacement of the cement slurry and provides a better quality of cement slurry around the bottom of the casing where a good cement bond to the casing is required.

Currently, two different cementing plugs are used in this cementing operation, one for the top and one for the bottom.

The bottom plug has a shearable member, such as the rubber diaphragm previously mentioned, which shears when a specific fluid pressure differential is applied thereto. The top plug is substantially solid. Because each plug requires different construction, separate molds must be used for each of the plugs which increase the costs of manufacturing, and also, the two separate plugs must be kept in inventory. The present invention solves this problem by using a single plug subassembly design which has the same general construction whether it is used as a top plug or a bottom plug. A shearable insert is positioned in one plug so that it may be used as a bottom plug. This shearable member is designed to shear at a predetermined differential pressure thereacross. In one embodiment, the shearable member is a flat disc, and in another embodiment, the shearable member has a relatively thin domed portion. Another insert, which is essentially non-shearable at the pressures in which the plugs are utilized, is positioned in another plug so that it can be used as a top plug. By the use of a single plug subassembly, with separate inserts, the cost of molds of the plugs is decreased, and only one plug must be maintained in inventory along with the different inserts.

Another advantage of the present invention is that the shearable member may be interchangeable with a plurality of shearable members, including, but not limited to, the two embodiments previously described, designed to shear at any one of a selected number of differential pressures as necessary for different well conditions. This is an improvement over the previous design which had essentially one shear pressure.

With prior art cementing plugs, the wiping efficiency of the wipers on the plugs is affected by pumping rate and wear along the casing surface. The cementing plug of the present invention provides an improved wiper design which offers more surface contact, and as the plug is pumped down the casing, wiping efficiency is increased. As a top cup on the plug wears, the pressure is transferred to a bottom cup which prolongs the surface engagement maintaining the wiping, resulting in extended wear.

SUMMARY OF THE INVENTION

The present invention is a universal cementing plug which may be configured as either a bottom cementing plug or a top cementing plug. The plug may also be described as an improved wiping and/or extended wear plug.

The cementing plug is adapted for use in cementing casing in a well and comprises a body member defining a central opening therethrough, an elastomeric jacket disposed around the body member and having a wiper cup extending therefrom for engaging an inner surface of the casing, and an insert disposed across the central opening in the body member for at least temporary closure thereof. The insert is one of a plurality of interchangeable inserts. These inserts include a shearable insert or disk adapted for shearing and thereby opening the central opening when a predetermined differential pressure is applied across the shearable insert and a substantially non-shearable insert or disk adapted for substantially permanent closure of the central opening. When the cementing plug is configured as a bottom plug, a shearable insert is used, and when the cementing plug is configured as a top plug, a non-shearable insert is used.

Each body member defines a recess adjacent to the central opening with an upwardly facing shoulder therein. When configuring the cementing plug as a bottom plug or a top plug, one of the inserts is disposed on the shoulder.

The invention may also be described as a cementing plug for use in cementing casing in a well, comprising a body

3

member and an elastomeric jacket disposed around the body member with a wiper cup having a substantially conical outer surface thereon extending upwardly and outwardly at an acute angle with respect to a longitudinal axis of the plug. The conical surface deflects into substantially cylindrical, wiping engagement with an inner surface of the casing when the plug is disposed therein. This provides a large wiping surface for improved wiping and increased wear. Preferably, the wiper cup is one of a plurality of such wiper cups. As the upper wiper cup wears, the pressure will be gradually applied to the next lower wiper cup which continues the wiping action. This also provides extended wear life.

Stated in another way, the invention is a cementing plug apparatus for use in cementing casing in a well. The apparatus comprises a first cementing plug and a second cementing plug.

The first cementing plug comprises a first body member defining a first central opening therethrough, a first jacket disposed on the first body member, and a replaceable first disk disposed adjacent to the first body member for temporarily closing the first central opening and subsequently shearing when subjected to a predetermined pressure, thereby opening the first central opening. The first jacket has a wiper cup extending therefrom adapted for wiping engagement with an inner surface of the casing.

The second cementing plug comprises a second body member defining a second central opening therethrough, a second jacket disposed on the second body member, and a replaceable second disk disposed adjacent to the second body member for substantially permanently closing the second central opening. The second jacket has a wiper cup extending therefrom adapted for wiping engagement with an inner surface of the casing.

In the preferred embodiment, the first and second body members are substantially identical, and the first and second jackets are substantially identical. The first and second disks are interchangeable. The first disk is a selected one of a plurality of disks which are shearable at a corresponding plurality of predetermined pressures.

Also in the preferred embodiment, the first body member defines a first shoulder therein, and the second body member defines a second shoulder therein. The first disk is disposed on the first shoulder, and the second disk is disposed on the second shoulder.

Numerous objects and advantages of the invention will become apparent as the following detailed description of the preferred embodiments is read in conjunction with the drawings which illustrate such embodiments.

BRIEF DESCRIPTION OF THE DRAWINGS

FIG. 1 shows a first embodiment of the universal cementing plug and system of the present invention in use in a wellbore.

FIG. 2 is a perspective illustrating a first embodiment of a shearable insert used in the cementing plug as a bottom plug.

FIG. 3 illustrates in perspective a substantially non-shearable insert for use in the cementing plug as a top plug.

FIG. 4 illustrates a longitudinal cross section of the cementing plug of FIGS. 1-3.

FIG. 5 shows a second embodiment of the universal cementing plug and system of the present invention in use in a wellbore.

FIG. 6 is a perspective illustrating a second embodiment of a shearable insert used in the cementing plug as a bottom plug.

4

FIG. 7 is a longitudinal cross section of the second embodiment shearable insert.

FIG. 8 illustrates a longitudinal cross section of the cementing plug as a bottom plug including the second embodiment shearable insert of FIGS. 6 and 7.

DESCRIPTION OF THE PREFERRED EMBODIMENTS

Referring now to the drawings, and more particularly to FIG. 1, a first embodiment of the universal cementing plug of the present invention is shown and generally designated by the numeral 10. Universal cementing plug 10 may also be referred to as an improved wiping and/or extended wear cementing plug. As will be further discussed herein, cementing plug 10 can be configured as a first embodiment bottom plug 10' or a top plug 10". Bottom plug 10' and a top plug 10" may be referred to together as a first embodiment cementing plug system.

Cementing plug 10 is designed for use in a casing 12 disposed in a wellbore 14. At the lower end of casing 12 is floating equipment, such as a casing float collar or float shoe 16, of a kind known in the art, having a valve 18 therein designed to allow cement to be pumped into an annulus 20 between casing 12 and wellbore 14 while preventing back-flow.

Referring now to FIGS. 2-3, the details of first embodiment cementing plug 10 will be discussed. Cementing plug 10 includes a plug subassembly 22 which comprises a body member 24 and a jacket 26 disposed around the body member. Body member 24 is made of any one of a number of drillable materials known in the art, such as aluminum, plastic, wood, etc. Jacket 26 is made of an elastomeric material and is molded onto the outer surface of body member 24.

Body member 24 has a substantially cylindrical configuration with an outer surface 28 and a central opening, such as a first bore 30, defined longitudinally therethrough. A larger second bore 32 is defined in the upper end of body member 24 such that an upwardly facing annular shoulder 34 is defined between first bore 30 and second bore 32. Thus, a recess is formed in the upper end of the central opening.

Jacket 26 has an upper radially outwardly extending lip 36 and a lower radially outwardly extending lip 38. Between upper lip 36 and lower lip 38 are a pair of upwardly opening cup portions 40 and 42. Cup portion 40 may be referred to as upper cup 40, and cup portion 42 may be referred to as lower cup 42. It will be seen that upper cup 40 and lower cup 42 extend upwardly and radially outwardly. As seen in FIG. 4, cups 40 and 42 extend at an angle with respect to a longitudinal axis of cementing plug 10, and thus are angled much more sharply with respect to body member 24 than are upper lip 36 and lower lip 38. Upper cup 40 has an acutely angled conical outer surface 44 which is deflected into substantial wiping engagement with the inner surface of casing 12 as seen in FIG. 1, and lower cup 42 has a similar acutely angled conical surface 46.

FIG. 2 illustrates a first embodiment of a shearable insert or disk 48 which is substantially flat and of uniform thickness. FIG. 3 illustrates a substantially solid, non-shearable insert or disk 50 which is also substantially flat. Either of inserts 48 and 50 may be positioned on shoulder 34 in body member 24 of first embodiment cementing plug 10. Referring to the right side of FIG. 4, non-shearable insert 50 is shown thus forming a top plug 10'. In the left side of FIG. 4, first embodiment shearable insert 48 is shown, thus illustrating a first embodiment bottom plug 10'.

First embodiment shearable insert 48 is made of a material which is easily shared or ruptured when a predetermined

5

differential pressure is applied thereacross. One typical material is rubber, but the invention is not intended to be so limited. The thickness of shearable insert **48** may be one of a plurality of available thicknesses so that the shear pressure may be predetermined as conditions dictate.

Non-shearable insert **50** is substantially thicker than shearable insert **48** and is designed to be substantially non-shearable when normal pressures are applied thereacross. Thus, non-shearable insert **50** provides substantially permanent closure of the central opening in the corresponding body member **24**.

Referring now to FIG. **5**, a second embodiment of the uniform cementing plug of the present invention is shown and generally designated by the numeral **60**. Universal cementing plug **60** may also be referred to as an improved wiping and/or extended-wear cementing plug. As will be further discussed here, cementing plug **60'** can be configured as a second embodiment bottom plug **60** or the same top plug **10''** as in first embodiment cementing plug **10**. Second embodiment bottom plug **60'** and top plug **10'** may be referred together as a second embodiment cementing plug system.

As with the first embodiment, second embodiment cementing plug **60** is designated for use in casing **12** disposed in wellbore **14**. Again, at the lower end of casing **12** is floating equipment, such as casing float collar or float shoe **16** having valve **18** therein. An annulus **20** is formed between casing **12** and wellbore **14**.

Referring now to FIGS. **6-8**, the details of second embodiment cementing plug **60** will be discussed. Cementing plug **60** includes the same plug subassembly **22** used in first embodiment cementing plug **10**. Therefore, the same reference numerals are used for the components of plug subassembly **22** in FIG. **8** as were used in FIG. **4** for the first embodiment. As with the first embodiment, in the second embodiment, upper lip **40** on jacket **26** has an acutely angled conical outer surface **44** which is deflected into substantial wiping engagement with the inner surface of casing **12** as seen in FIG. **5**, and lower cup **42** has a similar acutely angled conical surface **46**.

FIGS. **6** and **7** illustrate a second embodiment of a shearable insert or member **62**. Shearable insert **62** has an outer ring portion **64** and a relatively thin inner portion **66** which acts as a ruptured disk portion. In the preferred embodiment, but not by way of limitation, inner portion **66** has an outwardly convex, curvilinear configuration. Thus, inner portion **66** may also be referred to a domed portion **66**.

Domed portion **66** is integrally formed with outer ring portion **64** and extends upwardly and inwardly from the ring portion.

Domed portion **66** preferably has a variable thickness including a first thickness **X** at or near its center and a second thickness **Y** adjacent to an internal corner **68** formed on the inside between ring portion **64** and domed portion **66**. In the illustrated embodiment, first thickness **X** is less than second thickness **Y**. Corner **68** is preferably radiused.

EXAMPLES

Although various materials may be used for shearable insert **62**, a preferred material is 23570 glass-filled plastic from Baelow-Hunt, Inc., of Tulsa, Okla. This material has a working temperature range of room temperature to about 410° F.

6

The following table illustrates the pressure at which domed portion **66** shears based on different values of **X** and **Y** using this material.

X	Y	Shear Pressure
0.100°	0.125°	370 psi
0.125°	0.150°	700 psi
0.131°-0.135°	0.175°	1200 psi

In a preferred embodiment, but not by way of limitation, the height **Z** of domed portion **66** above ring portion **64** is approximately equal to center thickness **X** of domed portion **66**.

Second embodiment shearable material **62** may be positioned on shoulder **34** in body member **24** of plug subassembly **22** to form second embodiment bottom plug **60'**, as seen in FIGS. **5** and **8**.

In second embodiment cementing plug **60**, top plug **10''** used with bottom plug **60'** is identical to that in first embodiment cementing plug **10**.

OPERATION OF THE INVENTION

Referring again to FIGS. **1** and **5**, the operation of cementing plug systems **10** and **60** are shown, respectively. First, a bottom plug **10'** or **60'** is prepared by positioning a shearable insert **48** or **62**, respectively, in body member **24** of a plug subassembly **22**, and a top plug **10''** is similarly formed by positioning a non-shearable insert **50** in body member **24** of another plug subassembly **22**. Bottom plug **10'** or **60'** is dropped into casing **12** in a manner known in the art. Cement **70** is pumped into casing **12** above bottom plug **10'** or **60'**, thus forcing the bottom plug downwardly to displace mud and other fluid in casing volume **72** below bottom plug **10'** or **60'**. This mud is forced outwardly into well annulus **20** after opening of valve **18** in float shoe **16**.

Once the desired amount of cement **70** is pumped into casing **12**, top plug **10''** is dropped into the well, and additional fluid pumped into casing **12** to force top plug **10''** downwardly. The downward movement of top plug **10''**, forces cement **70** downwardly, and thus, bottom plug **10'** or **60'** is also forced downwardly until it lands only top of float shoe **16**. Additional pressure applied above upper plug **10''** will create a pressure differential across shearable insert **48** in bottom plug **10'** or shearable insert **62** in bottom plug **60'** until the insert shears. At this point, further pumping of fluid above top plug **10''** will force cement downwardly through first bore **30** in body member **24** of lower plug **10'** or **60'** and past valve **18** in float shoe **16** so that the cement is pumped into well annulus **20**. Pumping is stopped when top plug **10''** lands on top of bottom plug **10'** or **60'**, at which point all of the cement has been forced into well annulus **20**. Once the cement cures, top plug **10''**, bottom plug **10'** or **60'** and float shoe **16** may be drilled out of casing **12** as desired in a manner known in the art.

The sharply angled configuration of conical surfaces **44** and **46**, respectively, of upper cup **40** and lower cup **42** on jacket **26** of bottom plug **10'** or **60'** and top plug **10''** offers more surface contact with the inside of casing **12** than previous cementing plugs. When bottom plug **10'** or **60'** and top plug **10''** are positioned in casing **12**, conical surfaces **44** and **46** are compressed such that they are in flat, substantially cylindrical contact with the inner surface of the casing. As any of plugs **10'**, **60'** or **10''** moves outwardly through casing **12**, the pressure above the plug is first mostly applied to

7

upper cup **40**. As conical surface **44** wears and fluid pressure leaks therepast, the pressure is then applied to lower cup **42** and conical surface **46** thereof. Cementing plug **10** or **60** can be designed with any number of cups portions as well conditions dictate.

Because of the design of new cementing plug **10** or **60**, the operator of the well only has to maintain one plug subassembly **22** in inventory, along with the necessary corresponding number of shearable material **48** or **62** and non-shearable inserts **50**. Thus, inventory control is simpler than with prior art plugs. Further, by having a plurality of different shearable plugs **48** or **62**, the operator has the opportunity to select a shear pressure rather than use the single pressure previously available.

It will be seen, therefore, that the cementing plug of the present invention is well adapted to carry out the ends and advantages mentioned, as well as those inherent therein. While a preferred embodiment of the invention has been shown for the purposes of this disclosure, numerous changes in the arrangement and construction of parts may be made by those skilled in the art. All such changes are encompassed within the scope and spirit of the appended claims.

What is claimed is:

[1. A cementing plug for use in cementing casing in a well, comprising:

a body member defining a central opening therethrough;
an elastomeric jacket disposed around said body member and having a wiper cup extending therefrom for engaging an inner surface of the casing;

an insert disposed across said central opening in said body member for closure thereof, said insert being one of a plurality of interchangeable inserts; and

wherein said insert is a shearable member adapted for shearing and opening said central opening when a predetermined differential pressure is applied across said shearable member or a substantially non-shearable disk adapted for substantially permanent closure of said central opening.]

[2. The plug of claim **1** wherein said shearable member is made of a rupturable material.]

[3. The plug of claim **1** wherein said shearable member is a substantially flat disk having a substantially uniform thickness.]

[4. The plug of claim **1** wherein said shearable member comprises:

a ring portion; and
a domed portion extending from said ring portion.]

[5. The plug of claim **1** wherein:
said body member defines a shoulder in said central opening; and
said insert is disposed on said shoulder.]

[6. The plug of claim **1** wherein said wiper cup is one of a plurality of such wiper cups.]

[7. The plug of claim **1** wherein said wiper cup has an conical outer surface extending upwardly and outwardly at an acute angle with respect to a longitudinal axis of the plug.]

[8. A cementing plug for use in a cementing casing in a well, comprising:

a body member defining a central opening therethrough and having a longitudinal axis;

an elastomeric jacket disposed around said body member and having a wiper cup extending therefrom, said wiper cup defining a conical outer surface extending upwardly and outwardly at an acute angle with respect

8

to said longitudinal axis, wherein said outer surface is deflected into substantially cylindrical, wiping engagement with an inner surface of a casing when the plug is disposed therein;

an insert disposed in said central opening for at least temporary closure thereof, said insert being a selected one of a plurality of inserts; and

wherein said insert is a shearable member adapted for shearing and opening said central opening when a predetermined differential pressure is applied across said shearable member or a substantially non-shearable disk adapted for substantially permanent closure of said central opening.]

[9. The plug of claim **8** wherein said wiper cup is one of a plurality of said wiper cups.]

[10. The plug of claim **8** wherein said insert is positioned on a shoulder defined on said body member.]

[11. A cementing plug apparatus for use in cementing a length of well casing in a well, said apparatus comprising:

a pair of substantially identical plug subassemblies, each of said plug subassemblies comprising:

a generally cylindrical body member defining a central opening longitudinally therethrough; and

an outer jacket disposed around said body member, said jacket having a resilient wiper cup extending therefrom adapted for wiping engagement with an inner surface of said length of casing;

a shearable insert positionable in one of said body members for temporarily closing said central opening in said one body member and for rupturing and thereby opening said central opening in response to a predetermined differential pressure thereacross; and

a substantially non-shearable insert positionable in the other of said body members for substantially permanently closing said central opening in the other body member.]

[12. The apparatus of claim **11** wherein said jacket is made of an elastomeric material.]

[13. The apparatus of claim **11** wherein said wiper cup is one of a plurality of wiper cups extending from said jacket.]

[14. The apparatus of claim **11** wherein said wiper cup has an outer surface extending upwardly and outwardly at an acute angle with respect to a longitudinal axis of the corresponding body member.]

[15. The apparatus of claim **11** wherein:

said body member has a recess defined therein adjacent to said central opening;

said shearable insert is positioned in the recess of said one of said plugs; and

said non-shearable insert is positioned in the recess of the other of said plugs.]

[16. The apparatus of claim **11** wherein said shearable insert comprises:

a ring portion; and

a domed portion extending upwardly and outwardly from said outer ring portion.]

[17. The apparatus of claim **11** wherein said shearable insert comprises a substantially flat disk of substantially uniform thickness.]

[18. The apparatus of claim **11** wherein said non-shearable insert comprises a substantially flat disk of substantially uniform thickness.]

[19. A cementing plug apparatus for use in cementing casing in a well, said apparatus comprising:

a first cementing plug comprising:

a first body member defining a first central opening therethrough;

a first jacket disposed on said first body member, said first jacket having a wiper cup extending therefrom adapted for wiping engagement with an inner surface of the casing; and

a replaceable first insert disposed adjacent to said first body member for temporarily closing said first central opening and subsequently shearing when subjected to a predetermined pressure, thereby opening said first central opening; and

a second cementing plug comprising:

a second body member defining a second central opening therethrough;

a second jacket disposed on said second body member, said second jacket having a wiper cup extending therefrom adapted for wiping engagement with an inner surface of the casing; and

a replaceable second insert disposed adjacent to said second body member for substantially permanently closing said second central opening.]

[20. The apparatus of claim 19 wherein:

said first and second body members are substantially identical; and

said first and second jackets are substantially identical.]

[21. The apparatus of claim 20 wherein said second insert comprises a substantially flat disk.]

[22. The apparatus of claim 19 wherein said first and second inserts are interchangeable.]

[23. The apparatus of claim 19 wherein said first insert is a selected one of a plurality of inserts shearable at a corresponding plurality of predetermined pressures.]

[24. The apparatus of claim 23 wherein said first insert comprises a substantially flat disk.]

[25. The apparatus of claim 23 wherein said first insert comprises:

an outer ring portion; and

an inner domed portion integrally formed with said outer ring portion.]

[26. The apparatus of claim 19 wherein said first and second jackets are made of an elastomeric material.]

[27. The apparatus of claim 19 wherein:

said wiper cup on said first jacket is made of a pair of wiper cups; and

said second wiper cup on said second jacket is one of a pair of wiper cups.]

[28. The apparatus of claim 19 wherein said wiper cup on said first jacket and said wiper cup on said second jacket have a conical outer surface extending upwardly and outwardly at an acute angle with respect to a longitudinal axis of said first and second body members.]

[29. The apparatus of claim 28 wherein said wiper cups are made of an elastomeric material.]

[30. The apparatus of claim 19 wherein:

said first body member defines a first shoulder therein;

said second body member defines a second shoulder therein;

said first disk is disposed on said first shoulder; and

said second disk is disposed on said second shoulder.]

[31. A plug for use in a well casing, comprising:

a body member defining a central opening therethrough;

a jacket disposed around said body member and having a wiper cup extending therefrom for engaging an inner surface of the casing; and

an insert disposed in said central opening for at least temporary closure thereof, wherein said insert is a shearable member or a substantially non-shearable disk.]

[32. The plug of claim 31 wherein said insert is one of a plurality of shearable and non-shearable inserts.]

[33. The plug of claim 32 wherein said inserts are interchangeable.]

[34. The plug of claim 31 wherein said insert is a substantially flat disk having a substantially uniform thickness.]

[35. The plug of claim 31 wherein said shearable member is adapted for shearing and opening said central opening when a predetermined differential pressure is applied across said shearable member and said non-shearable disk is adapted for substantially permanent closure of said central opening.]

[36. The plug of claim 31 wherein said shearable member is made of a rupturable material.]

[37. The plug of claim 31 wherein said shearable member is one of a plurality of available thicknesses so that the shear pressure may be predetermined.]

[38. The plug of claim 37 wherein said ring portion and said domed portion are integrally formed.]

[39. The plug of claim 31 wherein said shearable member comprises:

a ring portion; and

a domed portion extending from said ring portion.]

[40. The plug of claim 31 wherein said insert is positioned on a shoulder defined on said body member.]

[41. The plug of claim 31 wherein said jacket is made of an elastomeric material.]

[42. The plug of claim 31 wherein said wiper cup is one of a plurality of such wiper cups.]

[43. The plug of claim 31 wherein said wiper cup has a conical outer surface extending upwardly and outwardly at an acute angle with respect to a longitudinal axis of the plug.]

[44. A plug for use in a well casing, comprising:

a body member defining a central opening therethrough; and

an insert positioned for at least temporary closure of said central opening, wherein said insert comprises:

an outer ring portion; and

an inner portion extending from said outer ring portion, wherein said inner portion is thinner than said outer ring portion and has a viable thickness.]

[45. The plug of claim 44 wherein said outer ring portion and said inner portion are integrally formed.]

[46. The plug of claim 44 wherein said outer ring portion and said inner portion form an internal corner.]

[47. The plug of claim 46 wherein said corner is radiused.]

[48. The plug of claim 44 wherein said inner portion has a first thickness at a center thereof and a second thickness at an outer portion thereof adjacent to said outer ring portion.]

[49. The plug of claim 48 wherein said inner portion is an outwardly convex domed portion.]

[50. The plug of claim 49 wherein said domed portion has a height above said outer ring portion approximately equal to said first thickness.]

[51. The plug of claim 48 wherein said first thickness is less than said second thickness.]

52. A cementing plug comprising:

a cylindrical body member having an opening extending longitudinally therethrough;

a jacket disposed around said body member having at least two wipers extending radially outward therefrom; and

11

a one-piece dome-shaped insert extending across the opening for temporarily closing the opening and adapted for being shearingly removed from the entire opening;

wherein the insert comprises an outer ring and an inner portion extending within the ring, wherein the inner portion has a variable thickness including a first thickness at the center thereof and a second thickness adjacent to an internal corner formed between the ring and the inner portion.

53. The cementing plug of claim 52 wherein the insert shears in response to a predetermined fluid pressure applied to one surface thereof.

54. The cementing plug of claim 53 wherein the cementing plug is adapted to be lowered into a well and the fluid pressure is created by introducing a fluid into the well.

55. The cementing plug of claim 54 wherein a passage is formed through the body member through which the fluid flows when the insert shears.

56. The cementing plug of claim 52 wherein the inner portion is thinner than the ring and is adapted to shear when subjected to the predetermined fluid pressure.

57. The cementing plug of claim 52 wherein the inner portion has an outwardly convex, curvilinear configuration.

58. The cementing plug of claim 52 wherein the height of the inner portion above the ring is approximately equal to the center thickness of the inner portion.

59. The cementing plug of claim 52 wherein the first thickness is less than the second thickness.

60. The cementing plug of claim 52 wherein the insert is fabricated from a material selected from the group consisting of rubber, plastic, and glass-filled plastic.

61. A cementing method comprising:

lowering a body into a well;

providing an opening in the body;

disposing a one-piece dome-shaped member across the opening; and

subjecting the member to a fluid pressure sufficient to shear the member and open the opening.

62. The method of claim 61 wherein the member shears in response to a predetermined fluid pressure applied against one surface of the member.

12

63. The method of claim 61 wherein the step of subjecting comprises introducing a fluid into the well.

64. The method of claim 63 wherein the opening is a passage through the body through which the fluid flows when the member shears.

65. The method of claim 61 wherein the sheared member falls from the opening to open the entire opening.

66. The method of claim 61 further comprising fabricating the member from a material selected from the group consisting of rubber, plastic, and glass-filled plastic.

67. A cementing method comprising:

lowering a body into a well;

providing an opening in the body;

providing a one-piece dome-shaped member having a first thickness at the center thereof and a second thickness spaced from the center that is different from the first thickness;

disposing the member across the opening; and

subjecting the member to a fluid pressure sufficient to shear the member and open the opening.

68. The method of claim 67 wherein the member shears in response to a predetermined fluid pressure applied against one surface of the member.

69. The method of claim 67 wherein the step of subjecting comprises introducing a fluid into the well.

70. The method of claim 67 wherein the opening is a passage through the body through which the fluid flows when the member shears.

71. The method of claim 67 wherein the sheared member falls from the opening to open the entire opening.

72. The method of claim 67 further comprising providing a ring around the member.

73. The method of claim 72 wherein the member is thinner than the ring and is adapted to shear when subjected to a predetermined fluid pressure.

74. The method of claim 73 further comprising fabricating the member from a material selected from the group consisting of rubber, plastic, and glass-filled plastic.

* * * * *