



US00RE41490E

(19) **United States**
(12) **Reissued Patent**
Ala-Luukko et al.

(10) **Patent Number:** **US RE41,490 E**
(45) **Date of Reissued Patent:** ***Aug. 10, 2010**

(54) **TRANSMISSION OF MULTIMEDIA MESSAGES BETWEEN MOBILE STATION TERMINALS**

5,724,407 A 3/1998 Bruno et al.

(Continued)

(76) Inventors: **Sami Ala-Luukko**, Lauttasaarentie 15 A 11, FIN 00200, Helsinki (FI); **Jussi Koski**, Knaackstrasse 16, 10405 Berlin (DE)

FOREIGN PATENT DOCUMENTS

EP 0 817443 A2 1/1998
WO WO 97/08906 3/1997
WO WO 98/19438 5/1998
WO WO 99/56445 11/1999
WO WO 99/61966 12/1999

(*) Notice: This patent is subject to a terminal disclaimer.

OTHER PUBLICATIONS

(21) Appl. No.: **11/603,355**

TSG-SA Working Group 1 (Services) Meeting #5, Source: Motorola, Siemens, BT, France Telecom, T-Mobil, Non-Realtime Multimedia Messaging Proposals, Sep. 27, 1999-Oct. 1, 1999, 3 Sheets.

(22) Filed: **Nov. 20, 2006**

Related U.S. Patent Documents

Reissue of:

(64) Patent No.: **6,718,168**
Issued: **Apr. 6, 2004**
Appl. No.: **10/135,161**
Filed: **Apr. 30, 2002**

(Continued)

Primary Examiner—Sonny Trinh
(74) *Attorney, Agent, or Firm*—Foley & Lardner LLP

(57) **ABSTRACT**

U.S. Applications:

(63) Continuation of application No. 11/400,073, filed on Apr. 6, 2006.

(51) **Int. Cl.**
H04M 3/42 (2006.01)
H04L 29/08 (2006.01)

(52) **U.S. Cl.** **455/412.1; 455/412.2; 455/413; 455/414.4**

(58) **Field of Classification Search** 455/412.1, 455/412.2, 413, 414.4, 403, 517, 560, 561, 455/445; 370/259, 310, 351, 471, 473, 474
See application file for complete search history.

A method and a system for transmitting messages containing multimedia information or content that enables transmission and communication of multimedia messages between subscribers connected to telecommunication systems of different system operators. The inventive system includes a first mobile station terminal from which a multimedia message is sent, a second mobile station terminal that is the intended recipient of the multimedia message, a digital mobile network, a first multimedia message server for receiving a multimedia message from the first mobile station terminal, a first address database associated with the first multimedia message server, a second multimedia message server for receiving the multimedia message from the first multimedia message server, an IP network for carrying communications between the first and second multimedia message servers, and a second address database associated with the second multimedia message server.

(56) **References Cited**

U.S. PATENT DOCUMENTS

5,706,211 A 1/1998 Beletic et al.

51 Claims, 2 Drawing Sheets

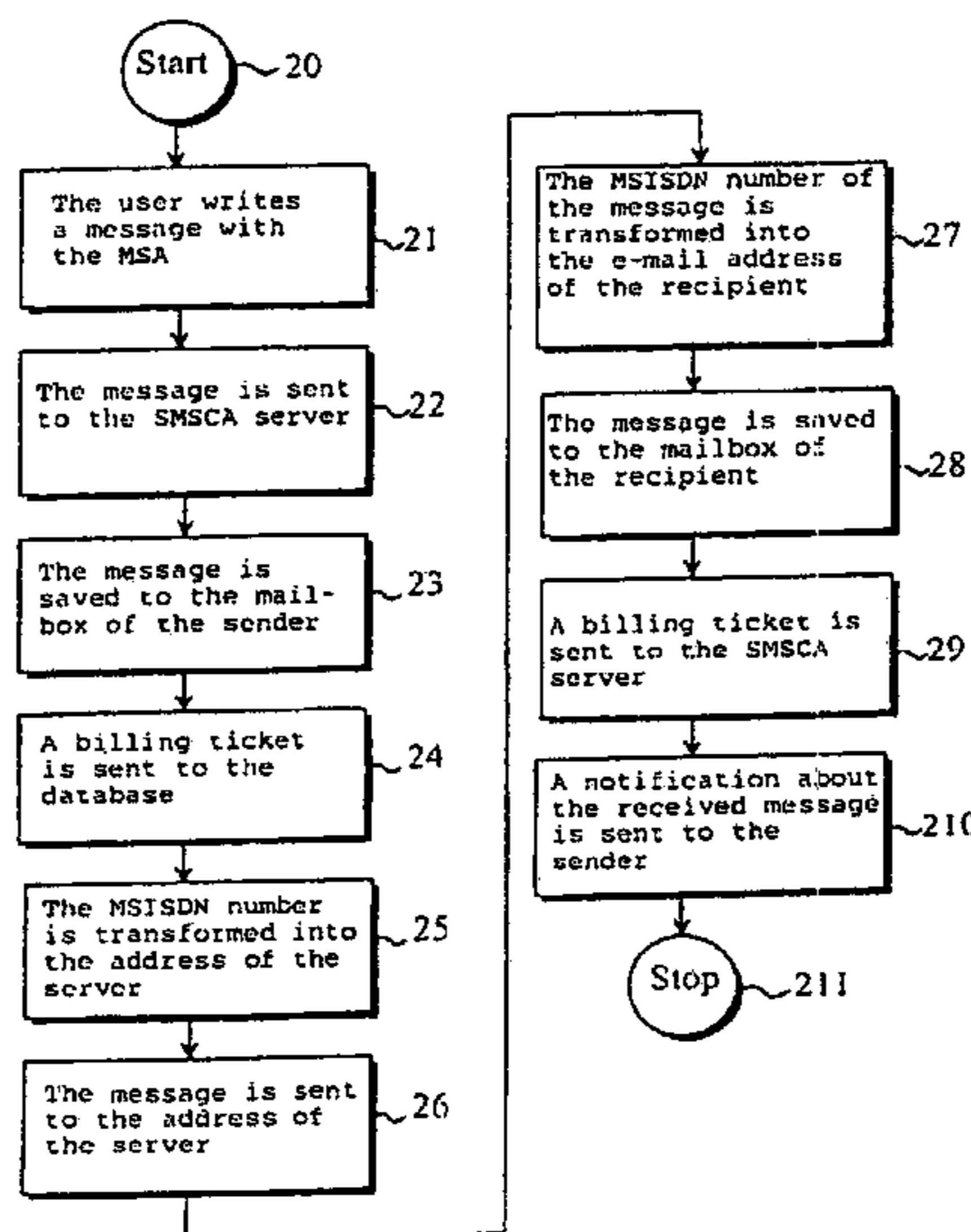

U.S. PATENT DOCUMENTS

5,742,905 A 4/1998 Pepe et al.
5,751,791 A 5/1998 Chen et al.
5,946,629 A * 8/1999 Sawyer et al. 455/466
5,974,449 A 10/1999 Chang et al.
6,195,345 B1 2/2001 Kramer
6,333,919 B2 12/2001 Gaffney
6,421,707 B1 7/2002 Miller et al.
6,438,114 B1 8/2002 Womack et al.
6,600,732 B1 7/2003 Sevanto et al.
6,895,251 B2 * 5/2005 Soh et al. 455/466
7,272,385 B2 * 9/2007 Mirouze et al. 455/414.1
7,333,822 B2 * 2/2008 Laumen et al. 455/466
2002/0132608 A1 9/2002 Shinohara

OTHER PUBLICATIONS

3GPP TSG-T2#4, Source: Nokia, Title; MMS Architecture Proposal, Jun. 14-16, 1999, 4 Sheets.
3G TS 23.040, Technical Specification, 3rdGeneration Partnership Project; Technical Specification Group Terminals; Technical Realization of the Short Message Service (SMS); Point-to-Point (PP), May 1999, 121 Sheets.
3G TS 23.140, Technical Specification, 3rdGeneration Partnership Project; Technical Specification Group Terminals; Multimedia Messaging Service (MMS); Functional Description, Stage 2, Oct. 1999, 15 Sheets.

* cited by examiner

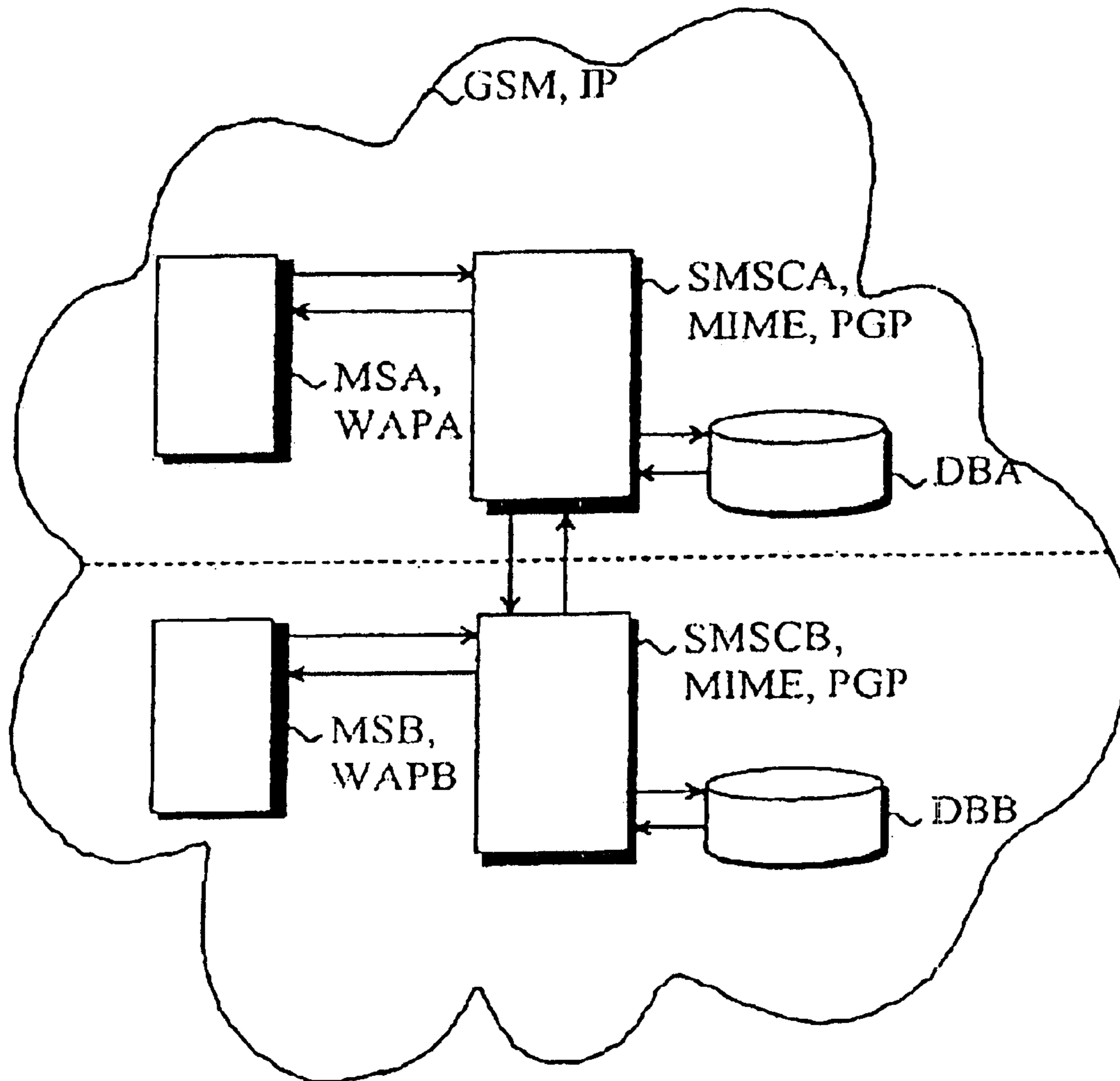

Fig. 1

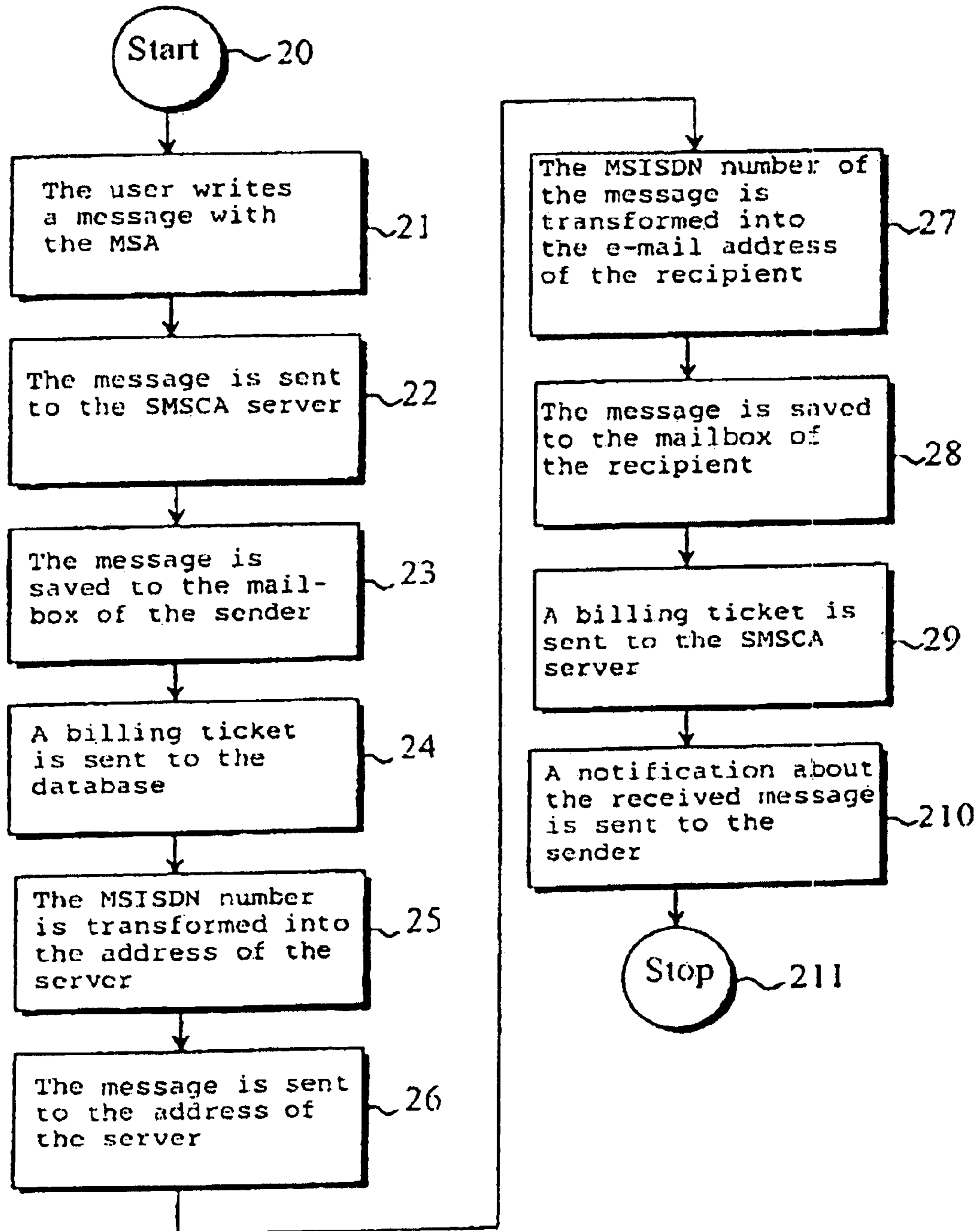

Fig. 2

**TRANSMISSION OF MULTIMEDIA
MESSAGES BETWEEN MOBILE STATION
TERMINALS**

Matter enclosed in heavy brackets [] appears in the original patent but forms no part of this reissue specification; matter printed in italics indicates the additions made by reissue.

*CROSS-REFERENCE TO RELATED
APPLICATIONS*

[This application is a continuation of] *More than one reissue application has been filed for the reissue of U.S. Pat. No. 6,718,168. The present application is a continuation reissue application of U.S. Pat. application Ser. No. 11/400,073 filed Apr. 6, 2006, which is a reissue application of U.S. Pat. No. 6,718,168, which claims priority to PCT/F100/00969 filed Nov. 6, 2000, which in turn claims priority to Finland Patent Application Number 19992399, filed Nov. 5, 1999.*

BACKGROUND OF THE INVENTION

1. Field of the Invention

The present invention generally relates to the telecommunications. In particular, the invention is directed to methods and apparatus for transmitting messages containing multimedia information or content between mobile station communication terminals.

2. Description of Related Art

The use of short messages for effecting communication between mobile stations of wireless telecommunication networks has become extremely common among wireless network subscribers over the past several years. Each such short message can have a maximum length of up to 160 characters. The transmission of short messages does not require that the mobile station be switched on since, if the mobile station cannot be reached at the time that the short message is sent, the message is saved to the short message service centre. The short message service centre retains the saved message for a period of several days and, when the mobile station to which the message has been directed is activated within the access range of the mobile network, the saved message is then transmitted to the activated mobile station. Such short messages may be transmitted either within the range or boundaries of the same cell or to other cells by means of the standard roaming features of mobile stations. Today these short messages are most typically, although not exclusively, transmitted in GSM (i.e. Global System for Mobile Communications) networks.

As is known, short messages may currently only be used for sending text-form, i.e. plaintext, messages. By virtue of the rapid development of technology, however, consumers will in the near future demand and be offered the ability to send and receive multimedia short messages consisting of a variety of different media components. But multimedia messages have not heretofore been standardized in any effective manner, so that whatever solutions are offered are likely to be operator and/or device-manufacturer specific. This will either in effect prevent the transmission of multimedia messages between the mobile stations of or serviced or supported by different system operators or manufacturers, or alternatively require the use of difficult and expensive implementations to enable such transmissions.

**OBJECTS AND SUMMARY OF THE
INVENTION**

It is accordingly the desideratum of the present invention to provide methods and apparatus that eliminate, or at least

significantly alleviate, the difficulties and drawbacks of the prior art, including those described hereinabove.

It is a particular object of the invention to provide a method and a system that enable the ready transmission of messages containing multimedia information or content between different telecommunication system operators or providers.

Broadly described, in the present invention a multimedia message is created and transmitted in a telecommunication network. The created multimedia message is sent from the first mobile station terminal, the sent message from the first terminal is further transmitted onward toward its ultimate destination (such as a second mobile station terminal), a notification informing of the multimedia message that has been sent is transmitted to the intended recipient second mobile station terminal, and the multimedia message is retrieved by and onto the second mobile station terminal device. As used herein, the term "multimedia message" is intended to denote a message which advantageously consists of or includes a plurality of different media components or content, such as an image, voice, text and/or graphics.

More particularly, and in accordance with the invention, a multimedia message addressed to an intended recipient is sent from the first mobile station terminal of the initiating sender to a first multimedia message server (with which the first mobile station is at least then associated) using the mobile communication network. The sent multimedia message is received by and saved on the first multimedia message server in the mailbox of the sender. If necessary, address information of a second multimedia message server (with which the second mobile station terminal of the intended recipient is associated) is located or identified using a first address database associated with or accessible by the first multimedia message server. An e-mail message based on the saved multimedia message is then created, and the created e-mail message is transmitted from the first multimedia message server to the second multimedia message server using an IP (Internet Protocol) network. A multimedia message based on the received e-mail message is then created using the second multimedia message server and is saved on the second multimedia message server in the mailbox of the intended second mobile terminal recipient; if necessary, the address of the second terminal device can be located or identified using a second address database associated with or accessible by the second multimedia message server. A notification informing the intended recipient of the multimedia message that has been stored by the second multimedia message server is then sent from the second multimedia message server to the second terminal device using the mobile communication network. If necessary—such as where the intended recipient of them message has no mailbox on the second multimedia message server—the multimedia message may be created or stored in a mailbox of its own on the second multimedia message server. Multimedia message servers may be implemented as separate units, or integrated with already-existing network components, as for example short message servers. The invention may be applied, by way of illustration, to a digital mobile network such as a GSM network, and the IP network may for example be any telecommunication network that utilizes or supports the IP protocol, such as the public Internet network.

In one or more embodiments of the invention, the e-mail message based on the multimedia message content may be created by coding the multimedia message content into an e-mail message in MIME format, as for example so that the text portion of the content serves as the plaintext message body and other portions of the multimedia message content

are sent as one or more attachments to the text portion. MIME (Multipurpose Internet Mail Extensions) format, as is well known, permits the combining and transmission of attachments to typically text-based e-mail messages.

In some embodiments of the invention, information that correlates the DNS (Domain Name Server) addresses and MSISDN (Mobile Subscriber ISDN) numbers of multimedia message servers of the network(s) is maintained in the first address database.

Similarly, information that correlates the MSISDN numbers and e-mail addresses of subscribers associated with or served by the second multimedia message server may be maintained in the second address database.

It is also contemplated that, in some embodiments of the invention, the multimedia message may be sent from the originating first mobile station terminal using a browser-type user interface that is incorporated or accessible in the terminal device of the initiating or sending subscriber. Such a browser-type user interface may advantageously be implemented using WAP (Wireless Access Protocol) technology.

The multimedia message may similarly be retrieved on the second mobile station terminal of the destination or receiving subscriber using a browser-type user interface incorporated or accessible in the second terminal device. This browser-type user interface may likewise be advantageously implemented using WAP technology.

In some embodiments of the invention, the e-mail to be transmitted is first encrypted, for which purpose any suitable encrypting device or application, and any convenient encrypting scheme such as the well-known PGP (Pretty Good Privacy) system, may be used. The e-mail message may also be transmitted using SMTP (Simple Message Transfer Protocol).

It is further contemplated that, in some embodiments, a billing ticket based on the multimedia message may be generated.

As compared with prior art methods and systems, the present invention renders it advantageously possible to send multimedia messages between the systems and mobile stations and subscribers of different telecommunication system operators. Since the invention utilizes existing, well-known and widely-available e-mail practices, it is particularly easy to implement and to expand its use throughout and among telecommunication systems. Moreover, the inventive methods and apparatus can utilize the public Internet and thus do not require the design or construction of dedicated connections between the multiple multimedia message servers. The optional use of encryption further assures that information security is not endangered.

Other objects and features of the present invention will become apparent from the following detailed description considered in conjunction with the accompanying drawings. It is to be understood, however, that the drawings are designed solely for purposes of illustration and not as a definition of the limits of the invention, for which reference should be made to the appended claims.

BRIEF DESCRIPTION OF THE DRAWINGS

In the drawings:

FIG. 1 is a schematic block diagram of a system constructed and arranged for the transmission of multimedia messages in accordance with the present invention; and

FIG. 2 is a flowchart of a method for the transmission of multimedia messages in accordance with the invention.

DETAILED DESCRIPTION OF THE CURRENTLY PREFERRED EMBODIMENTS

FIG. 1 is a block diagram depicting, by way of example, the components of an illustrative system configured in accor-

dance with the present invention. As seen in FIG. 1, the system comprises an originating first mobile station terminal MSA from which the multimedia message is sent, an intended recipient second mobile station terminal MSB to which the multimedia message is directed and by which it is ultimately received, and a digital mobile network GSM. The inventive system further includes a first multimedia message server SMSCA operable for receiving and saving the multimedia message from the first mobile station terminal MSA, for transforming the received message into an e-mail message, and for sending the transformed e-mail message to a second multimedia message server SMSCB; a first address database DBA for maintaining address information for the multimedia message servers and which is arranged as a part of, or for association with or access by or otherwise in conjunction with the first multimedia message server SMSCA; an Internet Protocol network IP for transmitting the e-mail message from the first multimedia message server SMSCA to a second multimedia message server SMSCB; the second multimedia message server SMSCB for transforming (or re-transforming) the e-mail message received from the first multimedia message server SMSCA into a multimedia message, for saving the transformed multimedia message and for sending a notification of receipt to the second terminal device MSB of the multimedia message that it has received and stored for eventual transmission to the second terminal device MSB; and a second address database DBB for maintaining address information for mobile subscribers associated with the second multimedia message server SMSCB and arranged as a part of, or for association with or access by or otherwise in conjunction with the second multimedia message server SMSCB. In addition, the FIG. 1 system of the invention comprises a coder MIME for encoding the multimedia message into an e-mail message in MIME format, and an encrypter or encrypting device or application PGP for encrypting the e-mail message to be transmitted by the first multimedia message server SMSCA to the second multimedia message server SMSCB. The first mobile station terminal MSA may include a browser-type user interface WAPA, and the second mobile station terminal MSB may similarly include a browser-type user interface WAPB.

The flow chart of FIG. 2 depicts, by way of example, a method in accordance with the present invention for sending a multimedia short message between two different telecommunication systems operators via an IP network. Initially, the user of the originating first mobile station terminal writes or creates a short message (block 21), and the short message is transmitted from the first mobile station terminal to the first short message service centre or server (block 22). In the short message service centre, the short message is temporarily saved to the mailbox of the sender (block 23), and a billing ticket is sent to the database (block 24). The destination address of the short message may for example be of the form +358400123456@mmm.operator.com. and, based on the designated country code and operator code, i.e. +358400 in this example, the e-mail server of the intended recipient is identified (block 25). To identify or correlate the country code, operator code and address of the e-mail server, a database is maintained in or otherwise associated with or accessible by the first short message service centre. The message is transmitted via the IP network to the server of (i.e. associated with) the intended recipient (block 26). During the period of the data transfer, multimedia information in the message is coded by a multipurpose Internet mail extension (i.e. MIME) and, to effect the transfer, a simple message transfer protocol (i.e. STMP) is employed. The specified destination address of the message is further examined at the

5

receiving server, which is itself provided or associated with a database by which the specified address (+358400123456@mmm.operator.com) of the message can be transformed into an e-mail message address format identifying the intended recipient, such as FirstName.FamilyName@mmm.operator.com (block 27). The message is then saved to the electronic mailbox of the recipient (block 28); if however there is no electronic mailbox for the recipient, then a new electronic mailbox is created. A billing ticket, based on the message that is transmitted to the server that sent the message, is created (block 29), and the intended recipient of the message is then sent the entire message or a part of the message (block 210). The message transmission type is selected based on the available features of the terminal device of the recipient and the network.

While there have been shown and described and pointed out fundamental novel features of the invention as applied to preferred embodiments thereof, it will be understood that various omissions and substitutions and changes in the form and details of the methods described and devices illustrated, and in their operation, may be made by those skilled in the art without departing from the spirit of the invention. For example, it is expressly intended that all combinations of those elements and/or method steps which perform substantially the same function in substantially the same way to achieve the same result are within the scope of the invention. Moreover, it should be recognized that structures and/or elements and/or method steps shown and/or described in connection with any disclosed form or embodiment of the invention may be incorporated in any other disclosed or described or suggested form or embodiment as a general matter of design choice. It is the intention, therefore, to be limited only as indicated by the scope of the claims appended hereto.

What is claimed is:

1. A method of transmitting a multimedia message from a first mobile station terminal of a sender to a second mobile station terminal of an intended recipient of the multimedia message, comprising the steps of:

transmitting the multimedia message from the first mobile station terminal to a first multimedia message server that receives the multimedia message from the first mobile station terminal via a mobile telecommunication network;

saving the received multimedia message on the first multimedia message server in a mailbox of the sender;

identifying, from the received multimedia message, address information of a second multimedia message server, optionally by utilizing a first database associated with the first multimedia message server;

creating, at the first multimedia message server, an e-mail message based on the received multimedia message;

transmitting the created e-mail message from the first multimedia message server to the second multimedia message server for receipt by the second multimedia message server;

creating a new multimedia message based on the e-mail message received by the second multimedia message server;

saving the created new multimedia message on the second multimedia message server in a mailbox of the recipient;

identifying, at the second multimedia message server, address information of the second mobile station terminal, optionally by utilizing a second database associated with the second multimedia message server; and

6

sending, from the second multimedia message server to the second mobile station terminal via the mobile communication network, a notification of the new multimedia message that has been saved by the second multimedia message server.

2. The method of claim 1, wherein said step of creating an e-mail message further comprises creating an e-mail message based on the multimedia message by coding the multimedia message into an e-mail message in MIME format.

3. The method of claim 1, wherein the first database comprises a first address database containing information correlating DNS addresses and MSISDN numbers of the first and second multimedia message servers.

4. The method of claim 1, wherein the second database comprises a second address database correlating MSISDN numbers and e-mail addresses of mobile subscribers associated with the second multimedia message server.

5. The method of claim 1, wherein said step of transmitting the multimedia message from the first mobile station terminal further comprises transmitting the multimedia message using a browser-type interface in the first mobile station terminal.

6. The method of claim 1, further comprising the step of retrieving the new multimedia message from the second multimedia message server onto the second mobile station terminal using a browser-type user interface in the second mobile station terminal.

7. The method of claim 1, further comprising the step of encrypting the created e-mail message to be transmitted to the second multimedia message server.

8. The method of claim 1, wherein said step of transmitting the created e-mail message from the first multimedia message server to the second multimedia message server further comprises transmitting the created e-mail message using SMTP protocol.

9. The method of claim 1, further comprising the step of generating a billing ticket based on the multimedia message.

10. A system for transmitting a multimedia message in a telecommunication network from a first mobile station terminal of a sender to a second mobile station terminal of an intended recipient of the multimedia message, said system comprising:

a second multimedia message server;

a first multimedia message server operable for receiving the multimedia message from the first mobile station terminal, for saving the received multimedia message, for transforming the received multimedia message into an e-mail message and for sending the e-mail message to the second multimedia message server;

a first address database associated with the first multimedia message server for maintaining address information of plural multimedia message servers of the telecommunication network;

an IP network for transmitting the e-mail message from the first multimedia message server to the second multimedia message server;

said second multimedia message server being operable for receiving the e-mail message from the first multimedia message server, for transforming the received e-mail message into a new multimedia message, for saving the new multimedia message and for sending to the second mobile station terminal a notification of the saved new multimedia message; and

a second address database associated with the second multimedia message server for maintaining address information of subscribers associated with the second multimedia message server.

11. The system of claim 10, further comprising a coder for coding the received multimedia message into MIME format.

12. The system of claim 10, wherein the first address database contains information correlating DNS addresses and MSISDN numbers of the plural multimedia message servers.

13. The system of claim 10, wherein the second address database contains information correlating MSISDN numbers and e-mail addresses of subscribers associated with the second multimedia message server.

14. The system of claim 10, wherein the first mobile station terminal includes a browser-type user interface.

15. The system of claim 10, wherein the second mobile station terminal includes a browser-type user interface.

16. The system of claim 10, further comprising an encrypter for encrypting the e-mail message to be sent from the first multimedia message server to the second multimedia message server.

17. A method of transmitting a multimedia message, comprising:

receiving a multimedia message from a first mobile station at a multimedia message server associated with a mobile operator, wherein the received multimedia message is destined for a second mobile station;

obtaining address information associated with the second mobile station, based upon the received multimedia message;

generating an e-mail message based upon the received multimedia message if the second mobile station is not associated with the mobile operator, wherein the e-mail message is formatted to be transformable back into the received multimedia message; and

transmitting the e-mail message to a server from a network interface.

18. The method according to claim 17, further comprising saving the received multimedia message.

19. The method according to claim 18, wherein the saving the received multimedia message comprises saving the received multimedia message on the multimedia message server in a mailbox.

20. The method according to claim 17, further comprising generating billing information based upon the received multimedia message.

21. The method according to claim 17, wherein the e-mail message comprises a mobile subscriber number associated with the second mobile station.

22. The method according to claim 17, wherein the e-mail message comprises a Multipurpose Internet Mail Exchange (MIME) formatted message.

23. The method according to claim 17, wherein the e-mail message is transmitted from the network interface using Simple Message Transfer Protocol (SMTP) and Internet Protocol (IP).

24. The method according to claim 17, wherein the address information associated with the second mobile station includes a mobile subscriber number that is correlated to a Domain Name Server (DNS) address.

25. The method according to claim 17, wherein the address information associated with the second mobile station includes a mobile subscriber number that is correlated to an email address.

26. The method according to claim 17, wherein the address information associated with the second mobile station includes a mobile subscriber number that is transformed to an email address format having a first name and a family name of the intended recipient associated with the second mobile station.

27. The method according to claim 17, wherein the received multimedia message includes a plurality of different media contents.

28. The method according to claim 17, wherein the received multimedia message includes at least one non-text content.

29. The method of claim 17, wherein the obtaining address information associated with the second mobile station further comprises accessing a database having address information associated with the mobile operator.

30. A system for transmitting a multimedia message, comprising:

means for receiving a multimedia message from a first mobile station at a multimedia message server associated with a mobile operator, wherein the received multimedia message is destined for a second mobile station;

means for obtaining address information associated with the second mobile station, based upon the received multimedia message;

means for generating an e-mail message based upon the received multimedia message if the second mobile station is not associated with the mobile operator, wherein the e-mail message is formatted to be transformable back into the received multimedia message; and

means for transmitting the e-mail message to a server from a network interface.

31. The system according to claim 30, further comprising means for saving the received multimedia message.

32. The system according to claim 30, further comprising means for generating billing information based upon the received multimedia message.

33. The system according to claim 30, wherein the e-mail message comprises a mobile subscriber number associated with the second mobile station.

34. The system according to claim 30, wherein the e-mail message comprises a Multipurpose Internet Mail Exchange (MIME) formatted message.

35. The system according to claim 30, wherein the e-mail message is transmitted from the network interface using Simple Message Transfer Protocol (SMTP) and Internet Protocol (IP).

36. The system according to claim 30, wherein the address information associated with the second mobile station includes a mobile subscriber number that is correlated to a Domain Name Server (DNS) address.

37. The system according to claim 30, wherein the address information associated with the second mobile station includes a mobile subscriber number that is correlated to an email address.

38. The system according to claim 30, wherein the received multimedia message includes a plurality of different media contents.

39. The system according to claim 30, wherein the received multimedia message includes at least one non-text content.

40. A system, comprising:

a multimedia message server configured to:

receive a multimedia message from a first mobile station associated with a mobile operator, wherein the received multimedia message is destined for a second mobile station;

obtain address information associated with the second mobile station, based upon the received multimedia message;

generate an e-mail message based upon the received multimedia message if the second mobile station is

not associated with the mobile operator, wherein the e-mail message is formatted to be transformable back into the received multimedia message; and transmit the e-mail message to a server from a network interface.

41. *The system according to claim 40, wherein the multimedia message server is further configured to save the received multimedia message.*

42. *The system according to claim 40, wherein the e-mail message comprises a mobile subscriber number associated with the second mobile station.*

43. *The system according to claim 40, wherein the e-mail message comprises a Multipurpose Internet Mail Exchange (MIME) formatted message.*

44. *The system according to claim 40, wherein the e-mail message is transmitted from the network interface using Simple Message Transfer Protocol (SMTP) and Internet Protocol (IP).*

45. *The system according to claim 40, wherein the address information associated with the second mobile station includes a mobile subscriber number that is correlated to a Domain Name Server (DNS) address.*

46. *The system according to claim 40, wherein the address information associated with the second mobile station includes a mobile subscriber number that is correlated to an email address.*

47. *The system according to claim 40, wherein the address information associated with the second mobile station includes a mobile subscriber number that is transformed to an email address format having a first name and a family name of the intended recipient associated with the second mobile station.*

48. *The system according to claim 40, wherein the multimedia message server is further configured to obtain address information associated with the second mobile station by accessing a database having address information associated with the mobile operator.*

49. *The system according to claim 40, further comprising a database.*

50. *The system according to claim 40, wherein the received multimedia message includes a plurality of different media contents.*

51. *The system according to claim 40, wherein the received multimedia message includes at least one non-text content.*

* * * * *