

US00RE41460E

(19) **United States**
(12) **Reissued Patent**
Wheeler

(10) **Patent Number:** **US RE41,460 E**
(45) **Date of Reissued Patent:** **Jul. 27, 2010**

(54) **HIGH-DENSITY FIBER DISTRIBUTION FRAME**
(75) Inventor: **Todd A. Wheeler**, Burnsville, MN (US)
(73) Assignee: **ADC Telecommunications, Inc.**, Eden Prairie, MN (US)
(21) Appl. No.: **10/391,052**
(22) Filed: **Mar. 18, 2003**

4,986,762 A	1/1991	Keith	439/131
4,995,688 A	2/1991	Anton et al.	385/53
5,100,221 A	3/1992	Carney et al.	385/135
5,129,030 A	7/1992	Petrunia	385/135
5,142,606 A	8/1992	Carney et al.	385/134
5,167,001 A	11/1992	Debortoli et al.	385/135
5,289,558 A	2/1994	Teichler et al.	385/135
5,335,349 A	8/1994	Kutsch et al.	257/135
5,353,367 A	10/1994	Czosnowski et al.	385/135
5,363,467 A	11/1994	Keith	305/135
5,402,515 A	3/1995	Vidacovich et al.	385/135
5,412,751 A *	5/1995	Siemon et al.	385/135
5,490,229 A	2/1996	Ghandeharizadeh et al.	385/135
5,511,144 A	4/1996	Hawkins et al.	385/135
5,570,450 A	10/1996	Fernandez et al.	385/135
RE38,311 E *	11/2003	Wheeler	385/135

Related U.S. Patent Documents

Reissue of:

(64) Patent No.: **5,497,444**
Issued: **Mar. 5, 1996**
Appl. No.: **08/446,428**
Filed: **May 22, 1995**

U.S. Applications:

(63) Continuation of application No. 08/180,970, filed on Jan. 21, 1994, now abandoned.

(51) **Int. Cl.**
G02B 6/44 (2006.01)
G02B 6/26 (2006.01)

(52) **U.S. Cl.** **385/135; 385/25; 385/59; 385/134**

(58) **Field of Classification Search** **385/25, 385/53, 59, 89, 135-137, 139**
See application file for complete search history.

(56) **References Cited**

U.S. PATENT DOCUMENTS

4,359,262 A	11/1982	Dolan	385/135
4,502,754 A	3/1985	Kawa	385/134
4,585,303 A	4/1986	Pinsard et al.	385/53
4,595,255 A	6/1986	Bhatt et al.	385/135
4,630,886 A	12/1986	Lauriello et al.	385/135
4,699,455 A	10/1987	Erbe et al.	385/89
4,717,231 A	1/1988	Dewez et al.	385/135
4,765,710 A *	8/1988	Burmeister et al.	385/134
4,792,203 A	12/1988	Nelson et al.	385/135

FOREIGN PATENT DOCUMENTS

AU	40995/85	10/1985
AU	8655314 A1	1/1986
DE	27 35 106	8/1977
DE	3308682	9/1984
EP	146478	12/1984
EP	149250	12/1984

OTHER PUBLICATIONS

“ITU Fiber Handbook,” 7 pages.

(Continued)

Primary Examiner—Charlie Peng

(74) *Attorney, Agent, or Firm*—Merchant & Gould P.C.

(57) **ABSTRACT**

A fiber distribution frame includes a fixture having a plurality of modules mounted side-by-side within said fixture with each of the modules being individually mounted in a line of travel. Each of the modules can be locked in any one of a plurality of discrete positions within the line of travel. Each of the modules contains a plurality of adapters for receiving and retaining fiber optic connectors. Further, the fixture may be tilted downwardly to provide access to the rear of the fixture.

13 Claims, 18 Drawing Sheets

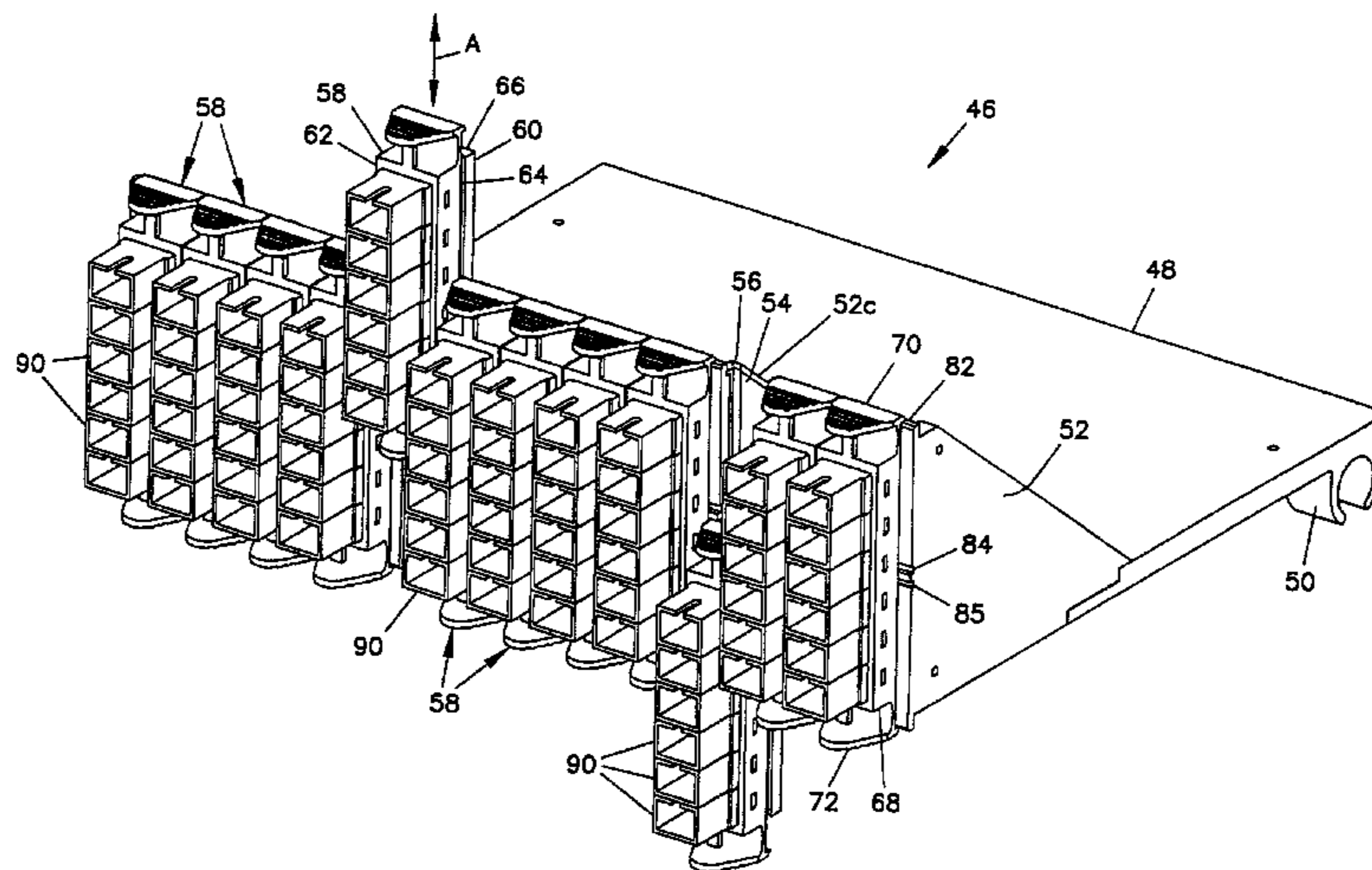

US RE41,460 E

Page 2

FOREIGN PATENT DOCUMENTS		
EP	196102	10/1986
EP	0406151	1/1991
EP	479226	4/1992
EP	196102 B1	3/1993
EP	0538164	4/1993
FR	2531576	2/1984
FR	2587127	3/1987
JP	59-74523	4/1984
JP	60-169811	9/1985
JP	61-55607	3/1986
JP	61-90104	5/1986

WO WO 91/10927 7/1991

OTHER PUBLICATIONS

English translation of Exhibit A, 7 pages.
"Precision Mechanical," 3 pages.
English translation of Exhibit B, 2 pages.
Northern Telecom bulletin #91-004, Issue #2, May 1991.
AT&T product bulletin 2987D-DLH-Jul. 1989, Issue 2.
Preface to the book, "Structure, Installation, Connection and Protection of Communication Optical Fiber Cable", 7 pages, Jun. 20, 1994.

* cited by examiner

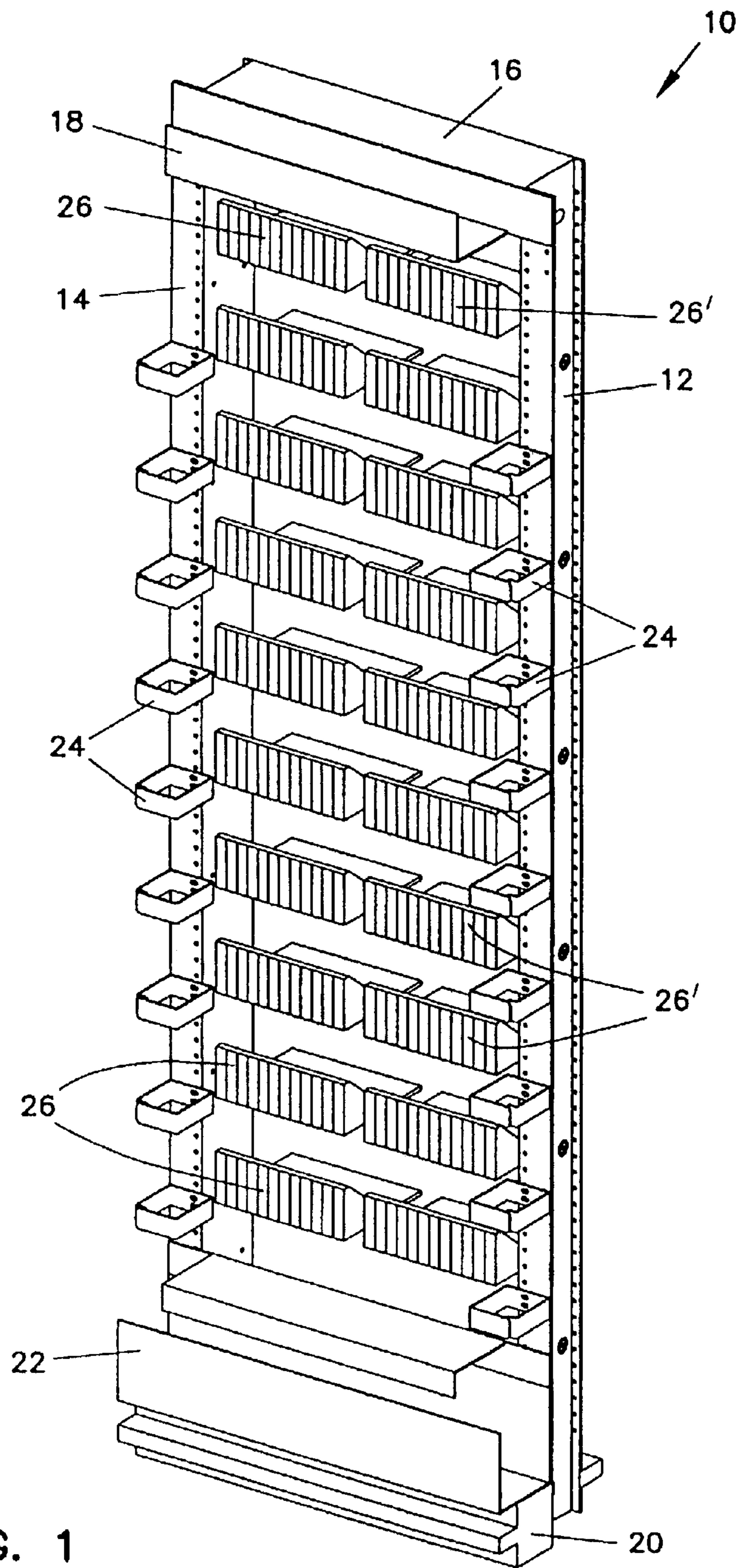

FIG. 1

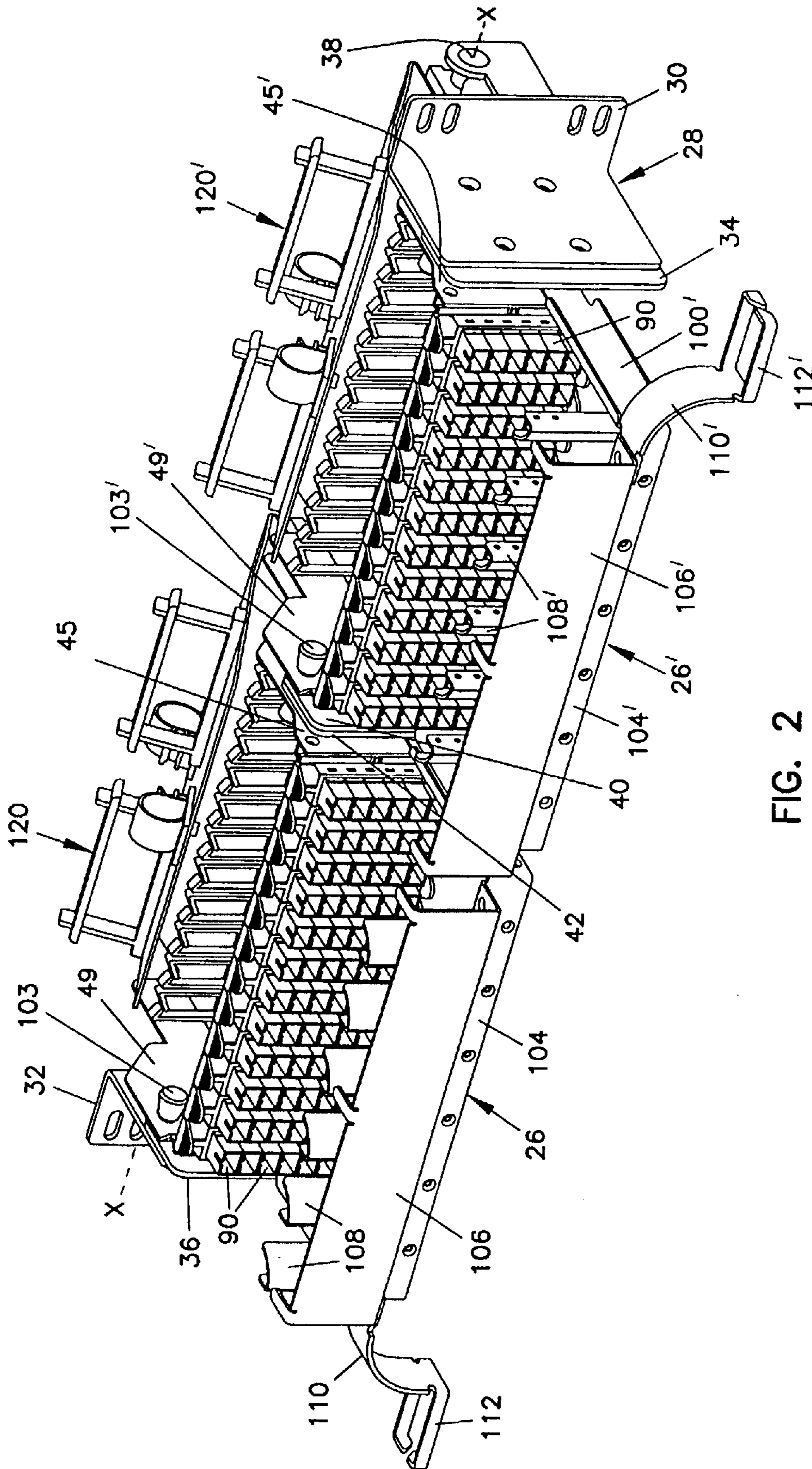

FIG. 2

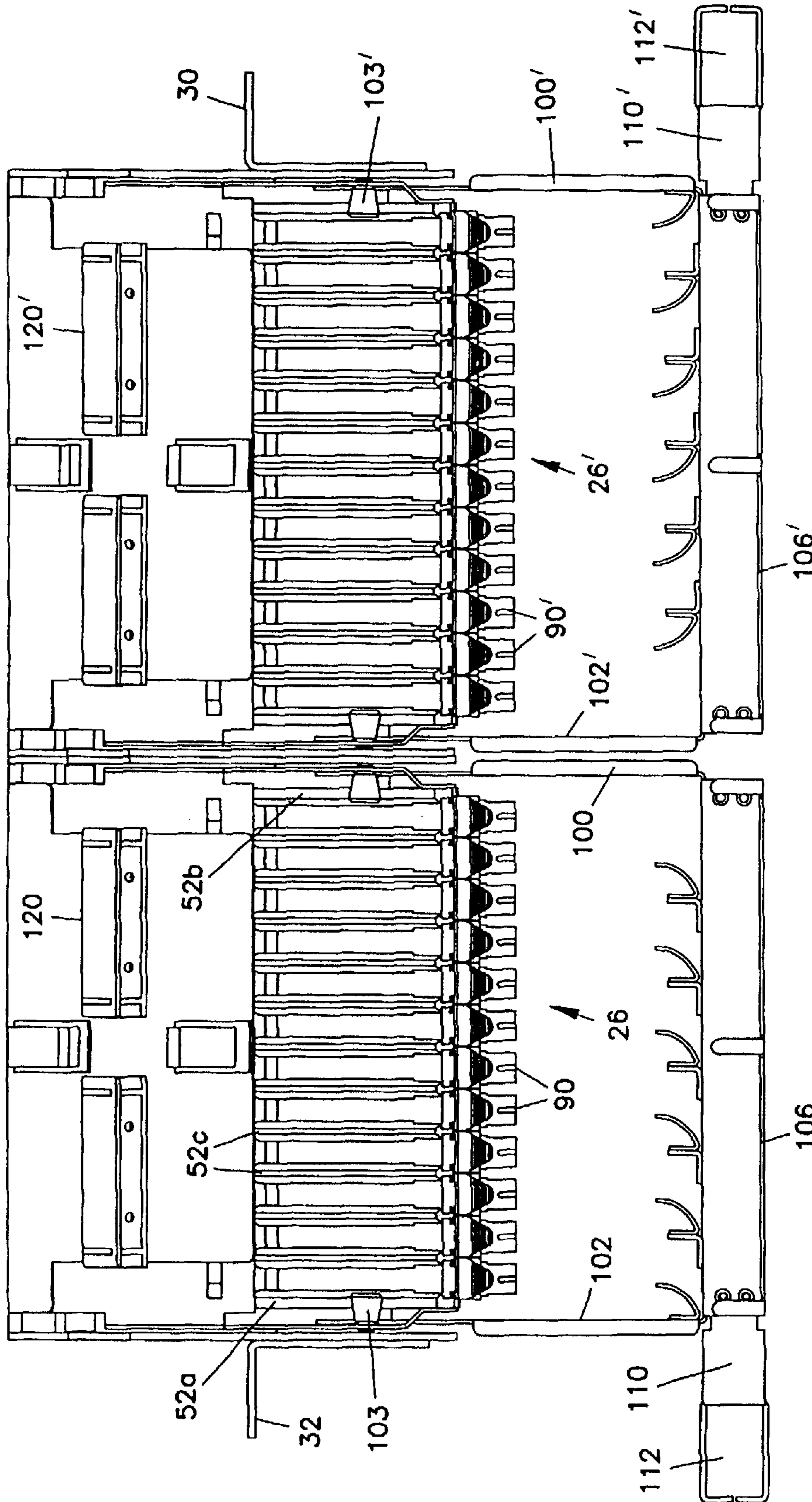

FIG. 3

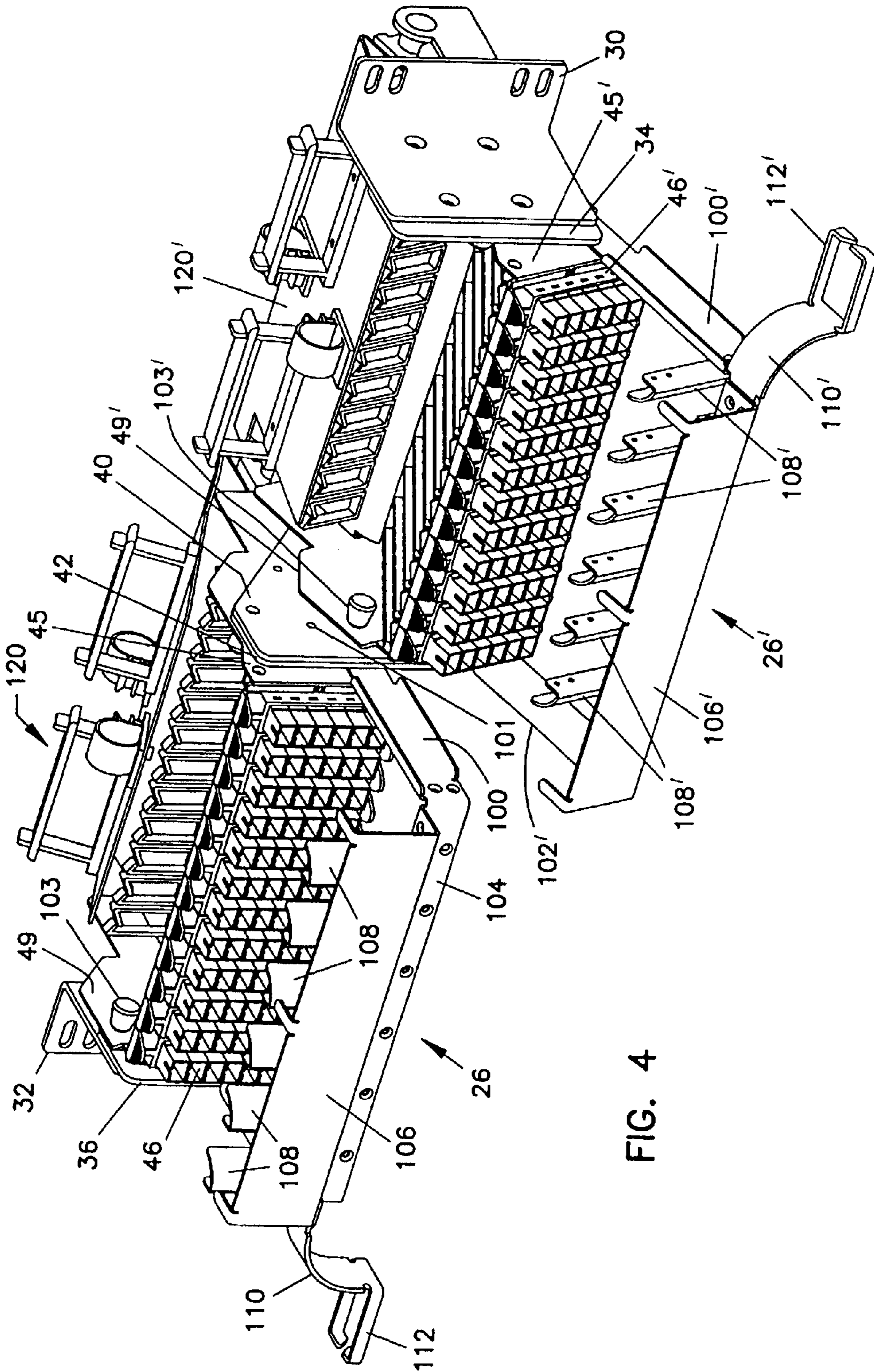

FIG. 4

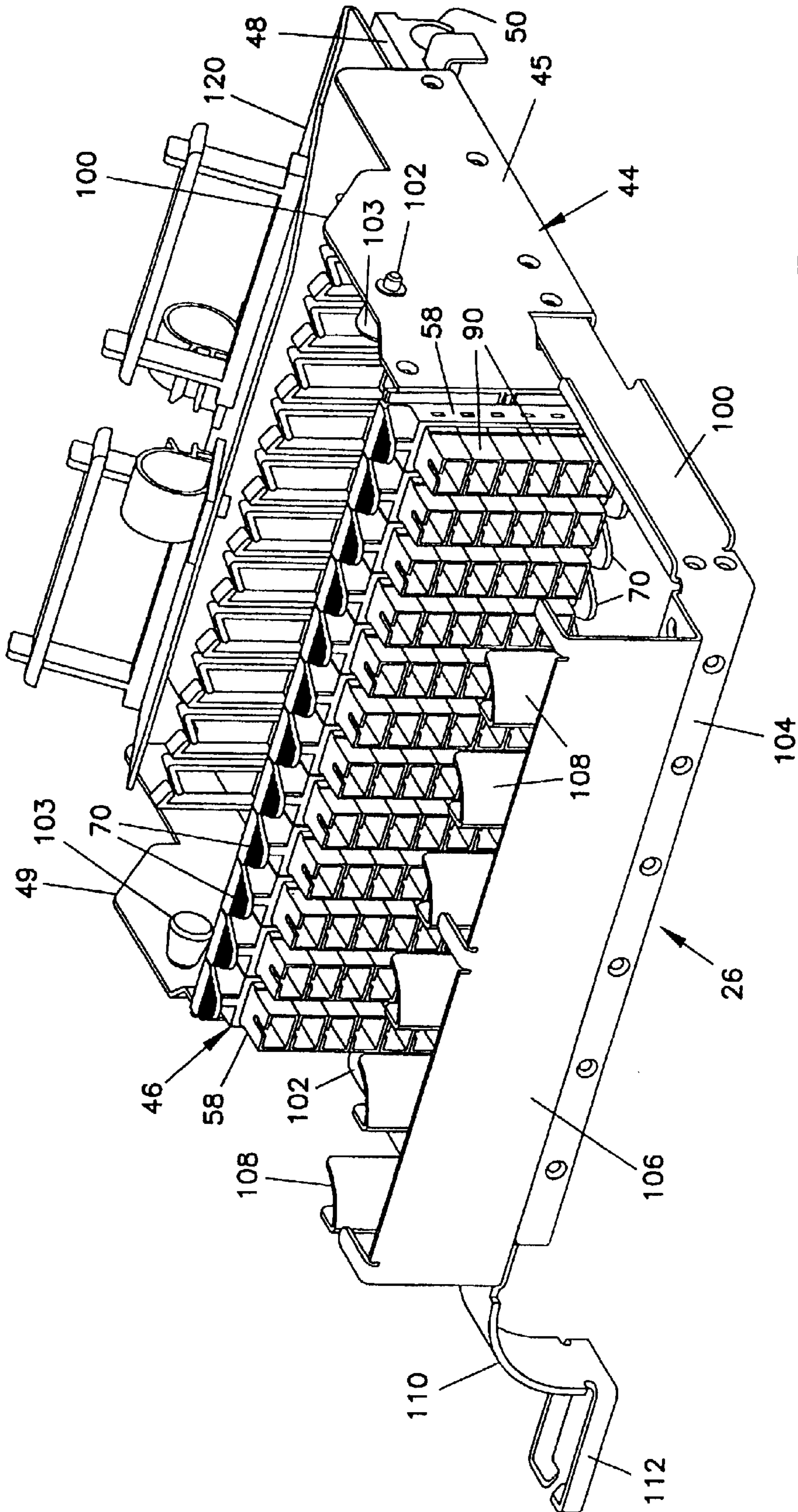
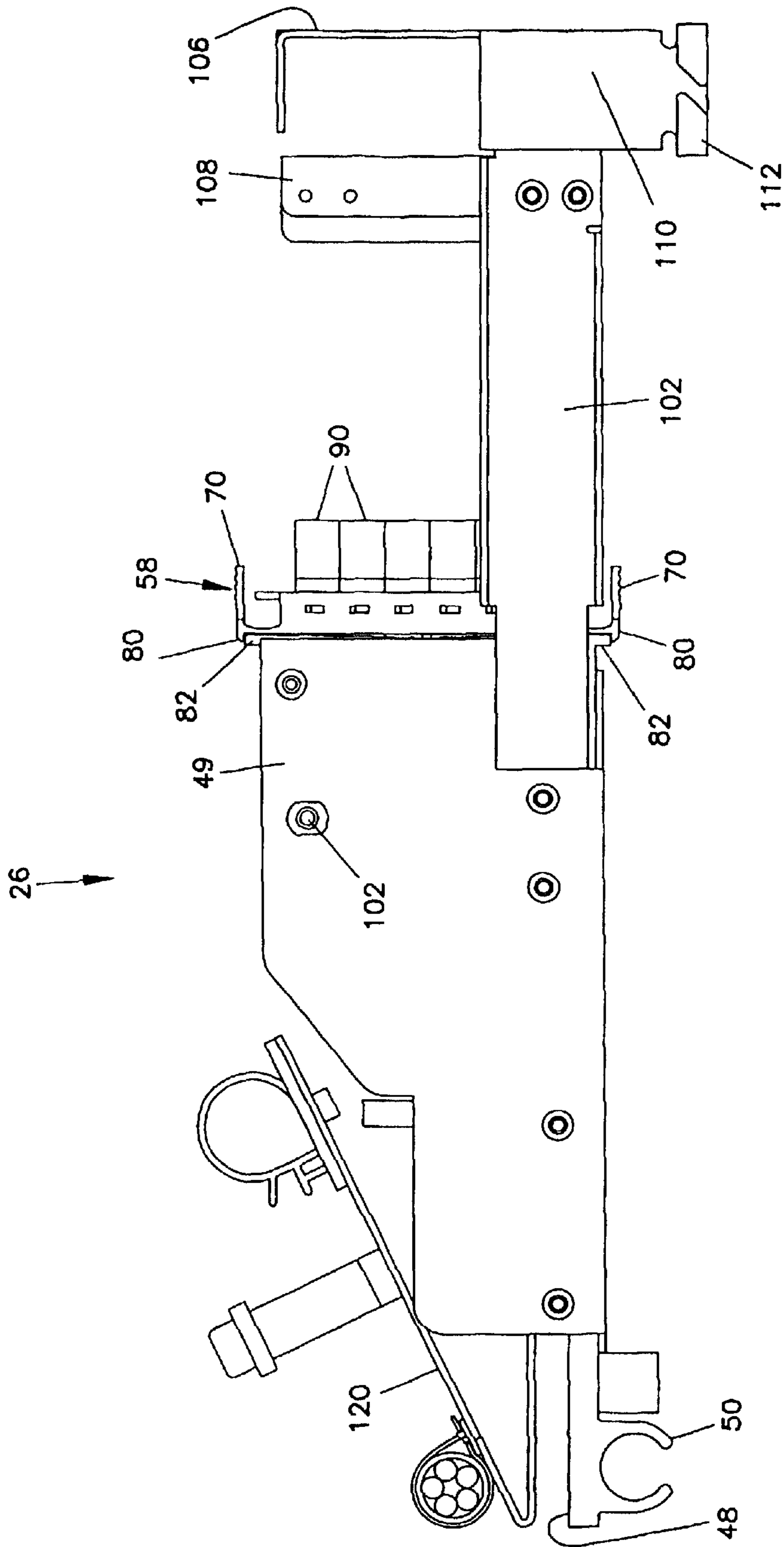

FIG. 5



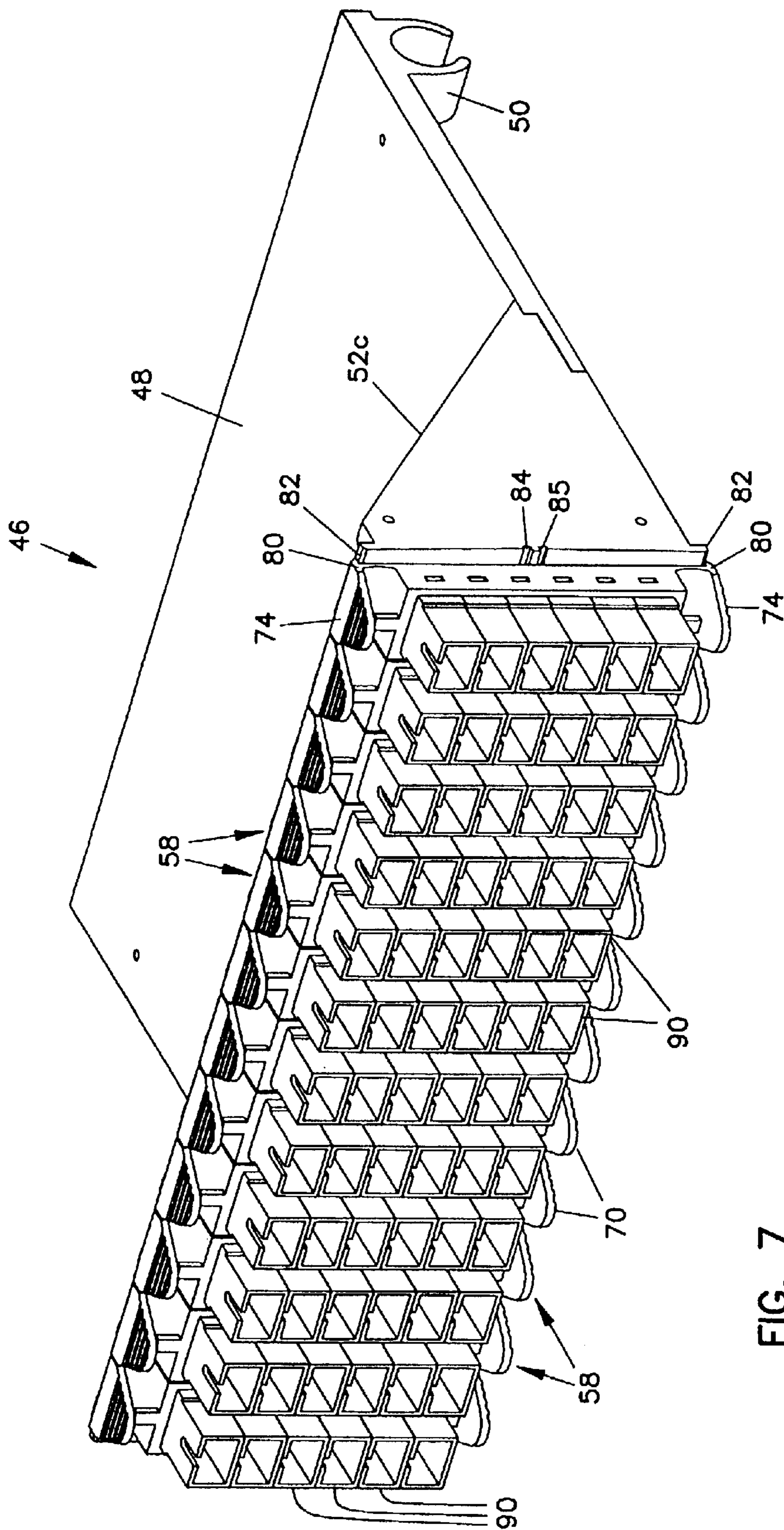

FIG. 7

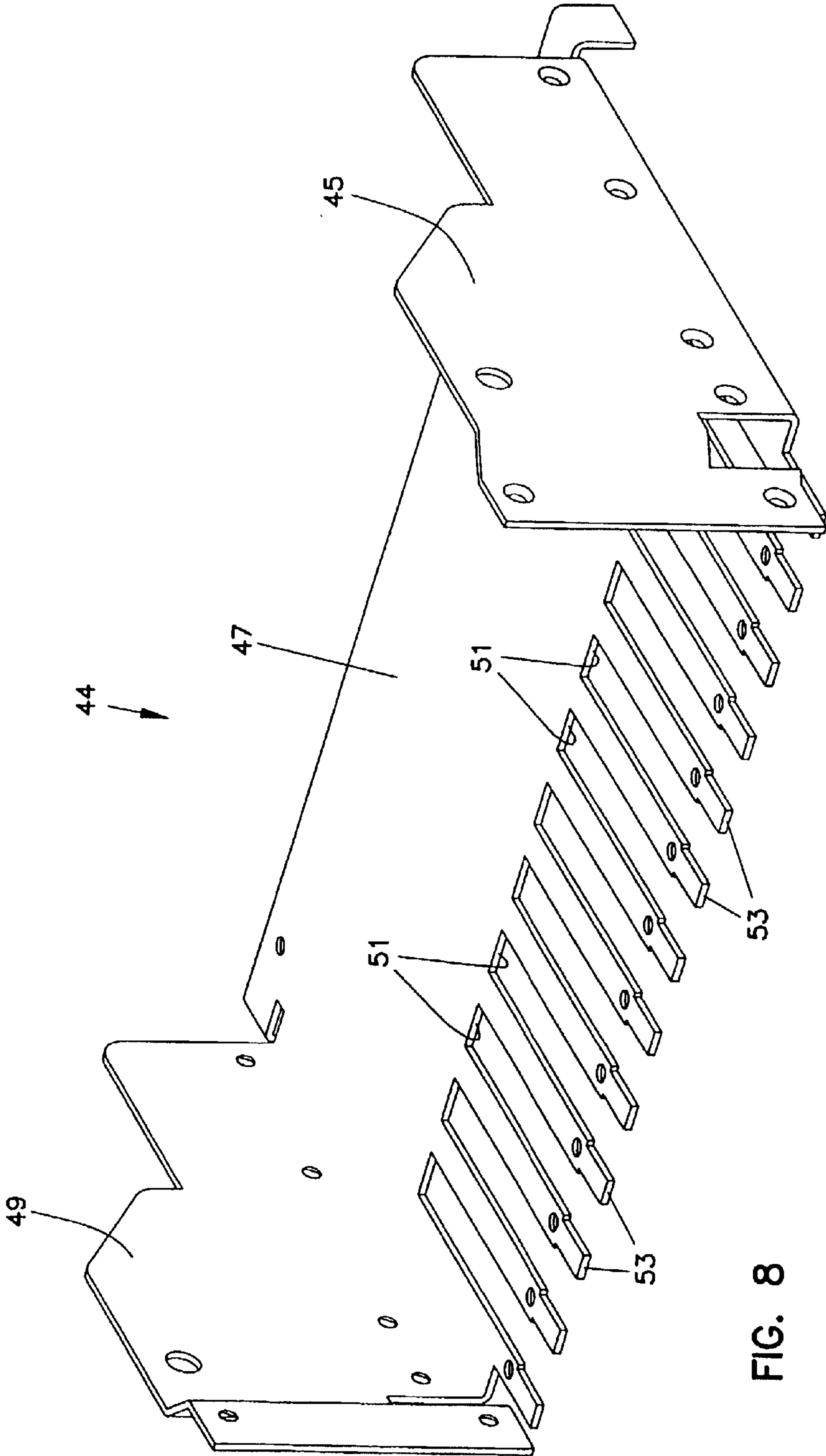
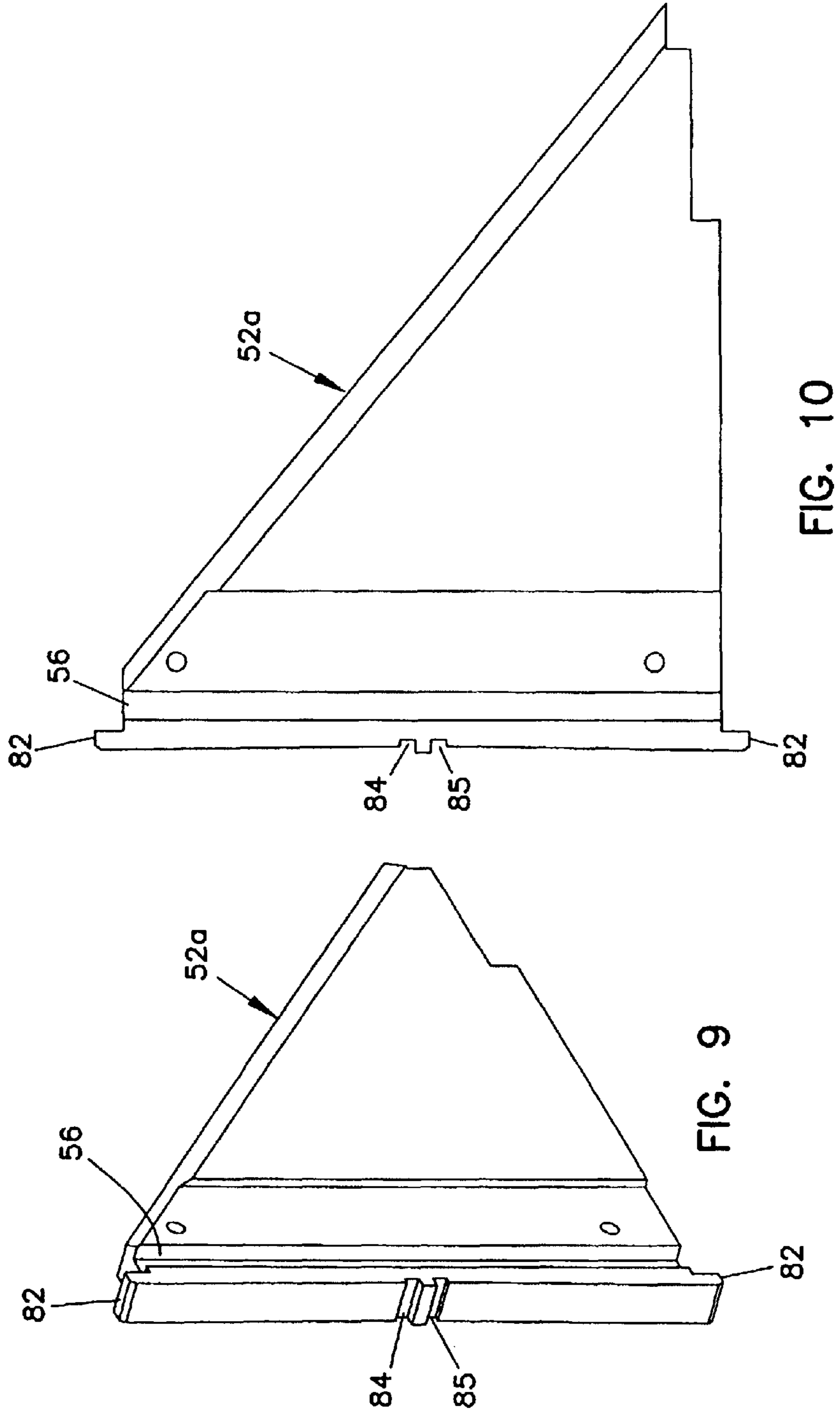

FIG. 8



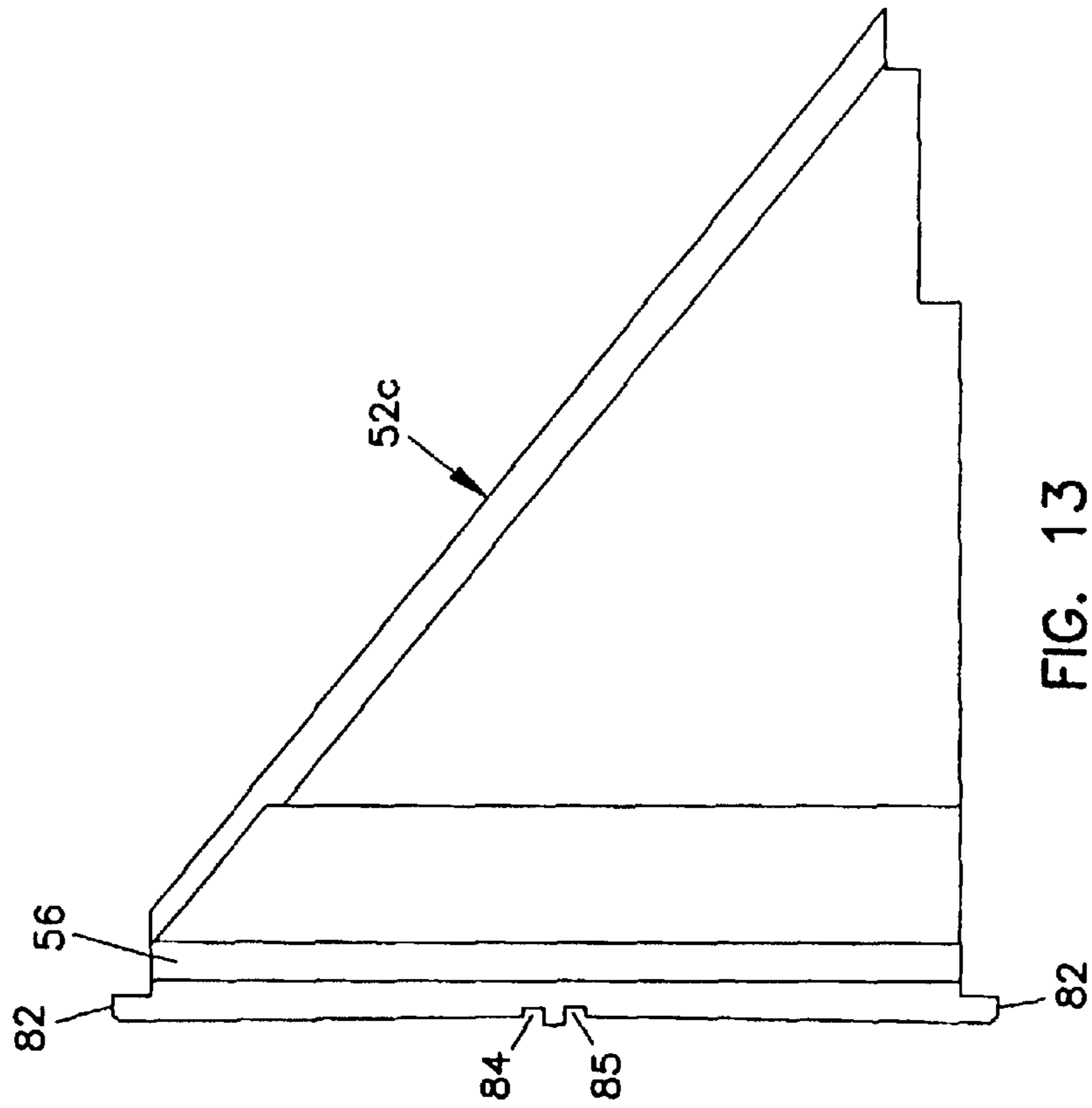

FIG. 12

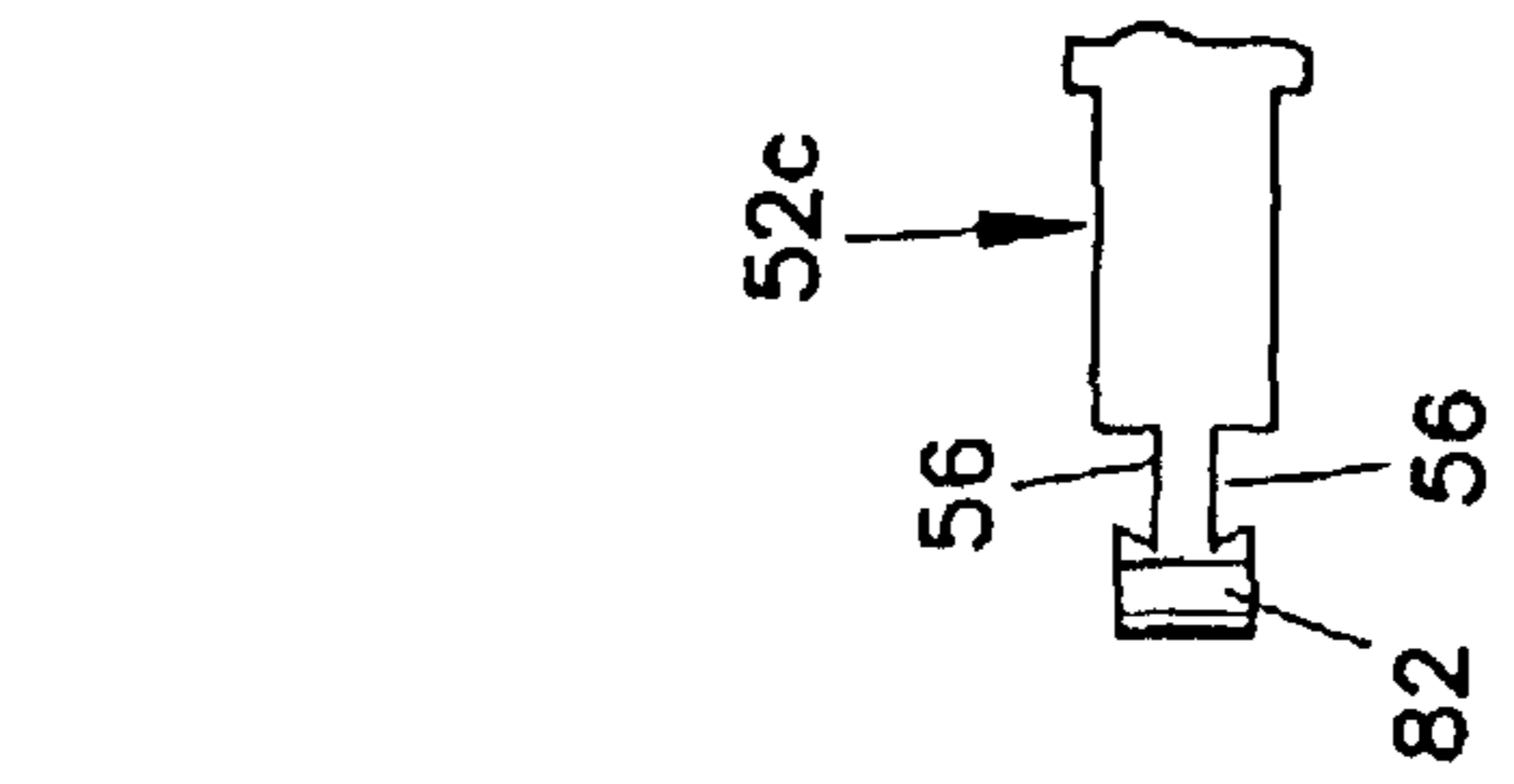

FIG. 13

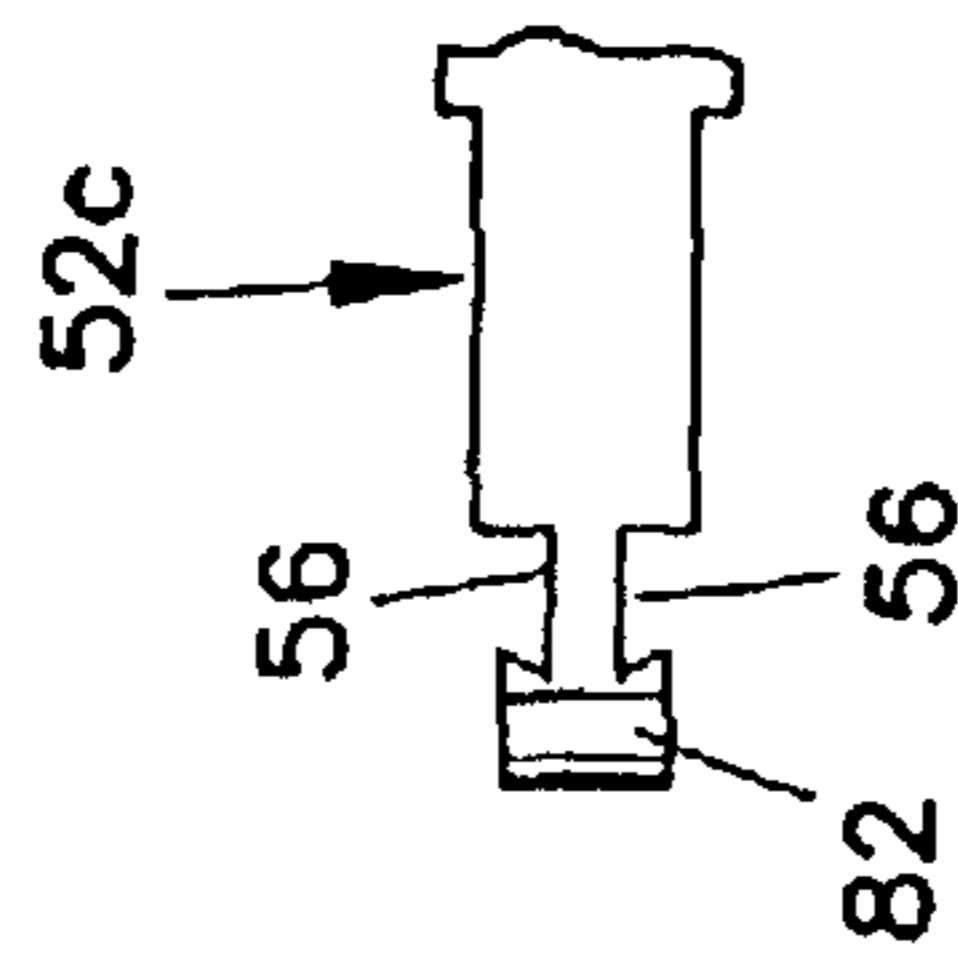

FIG. 14

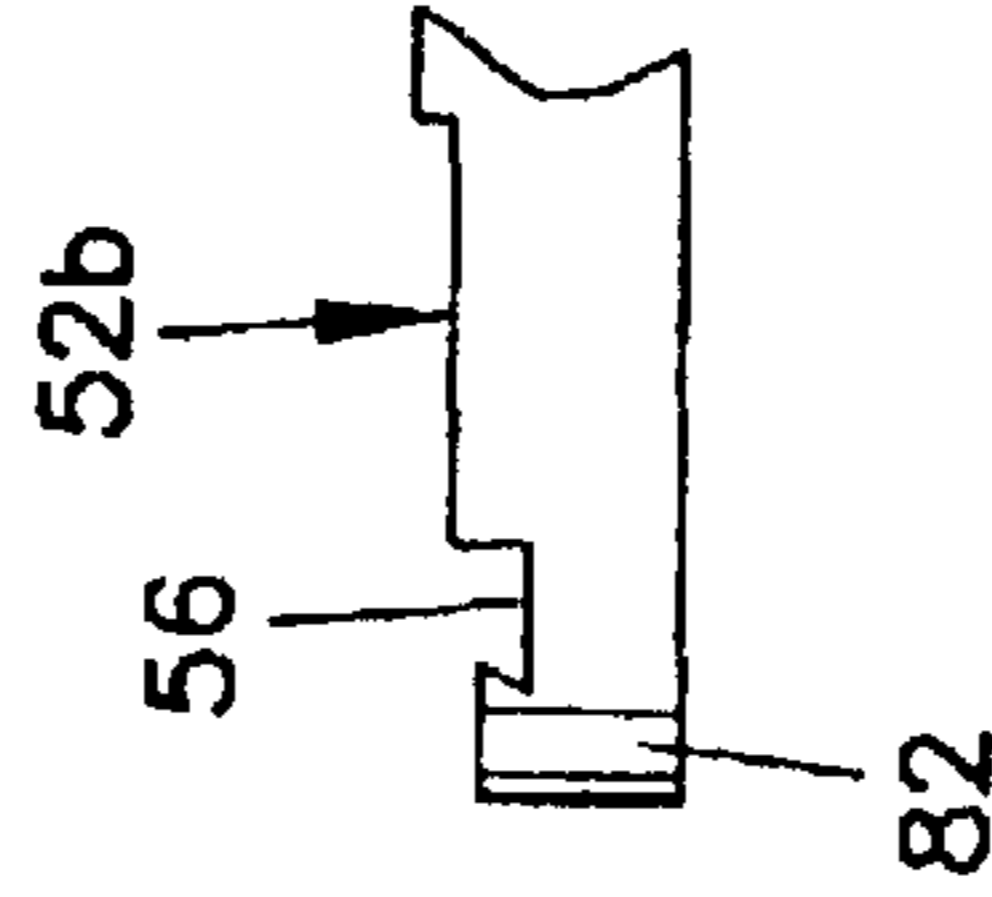
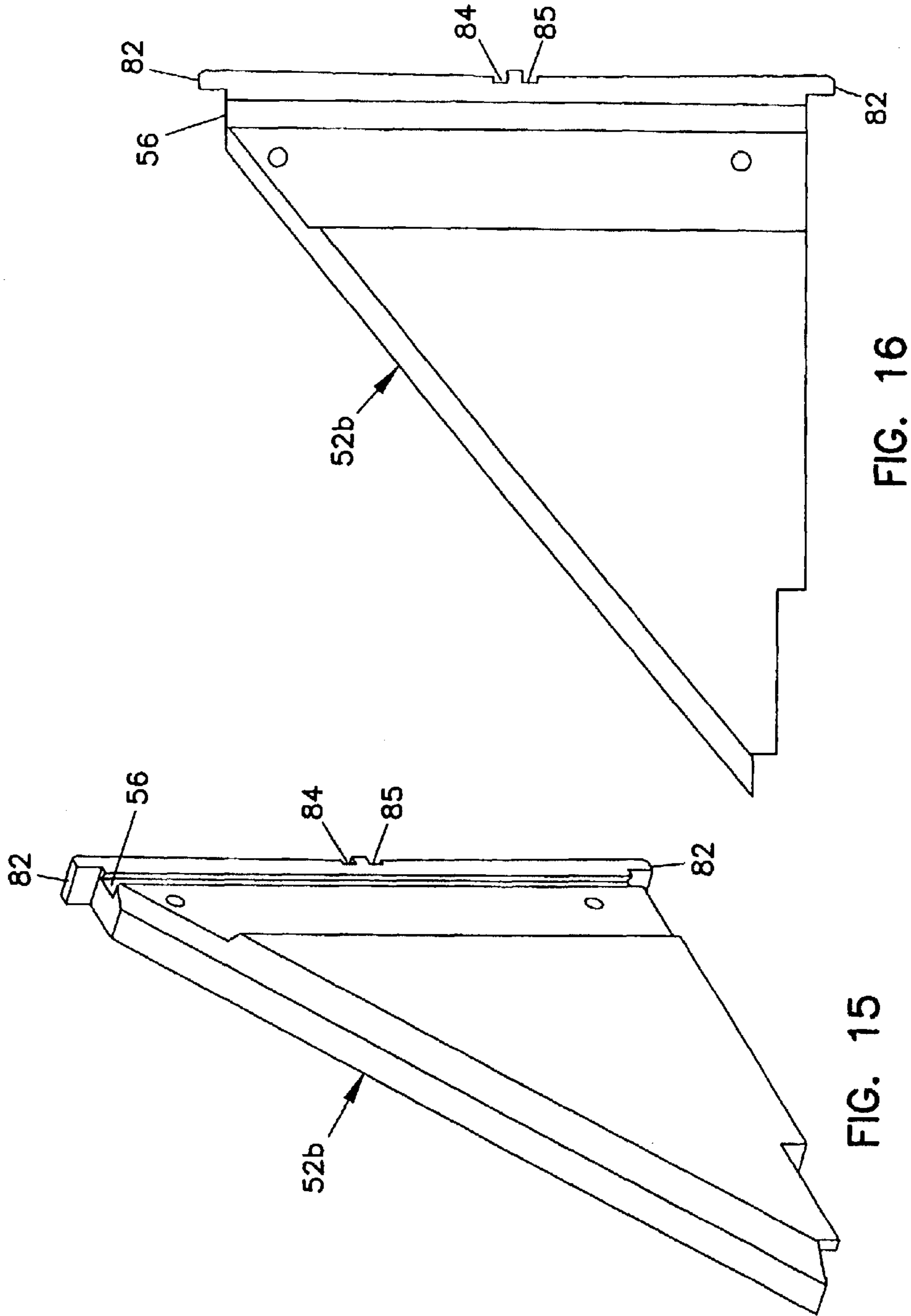

FIG. 17

FIG. 15

FIG. 16

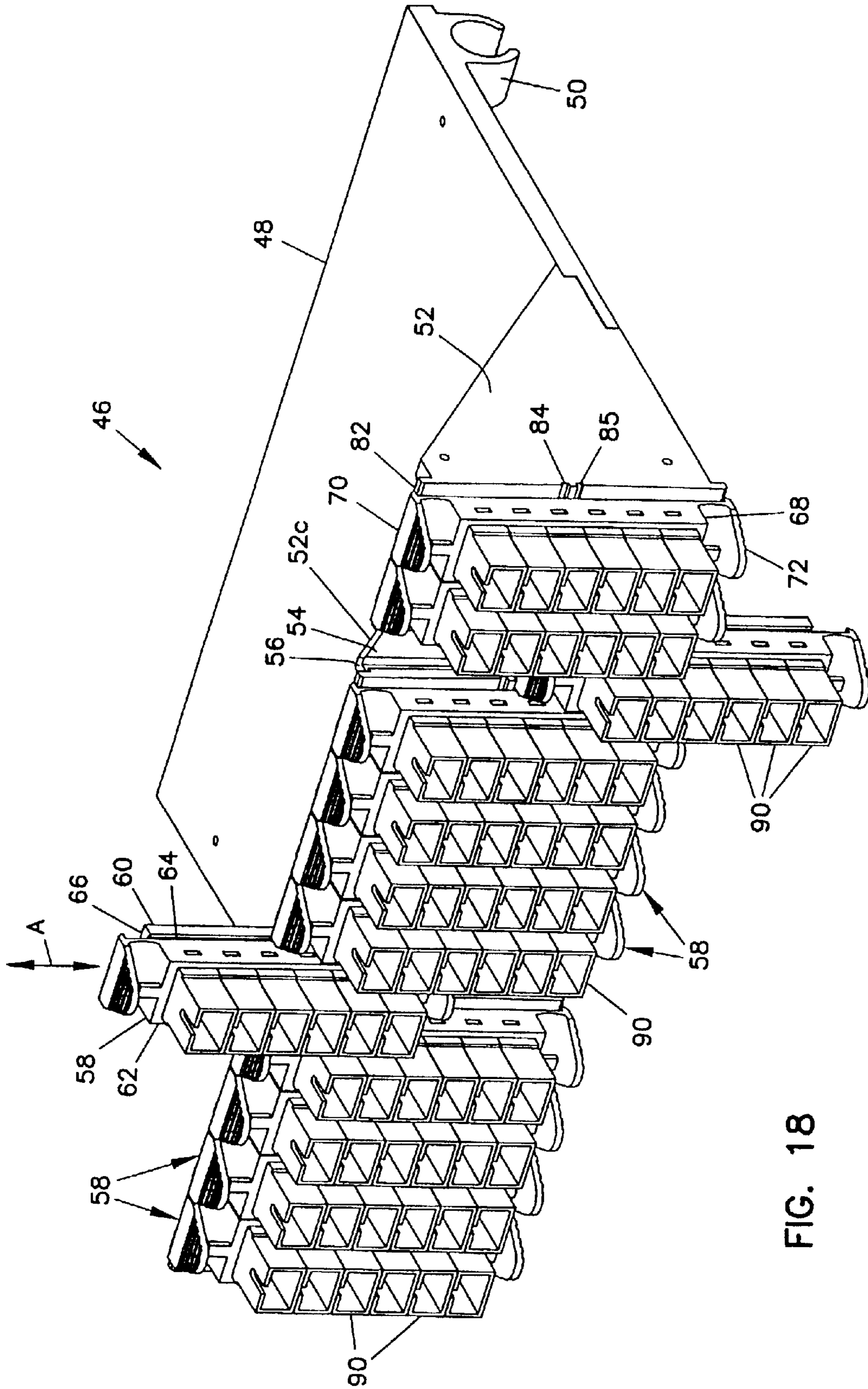

FIG. 18

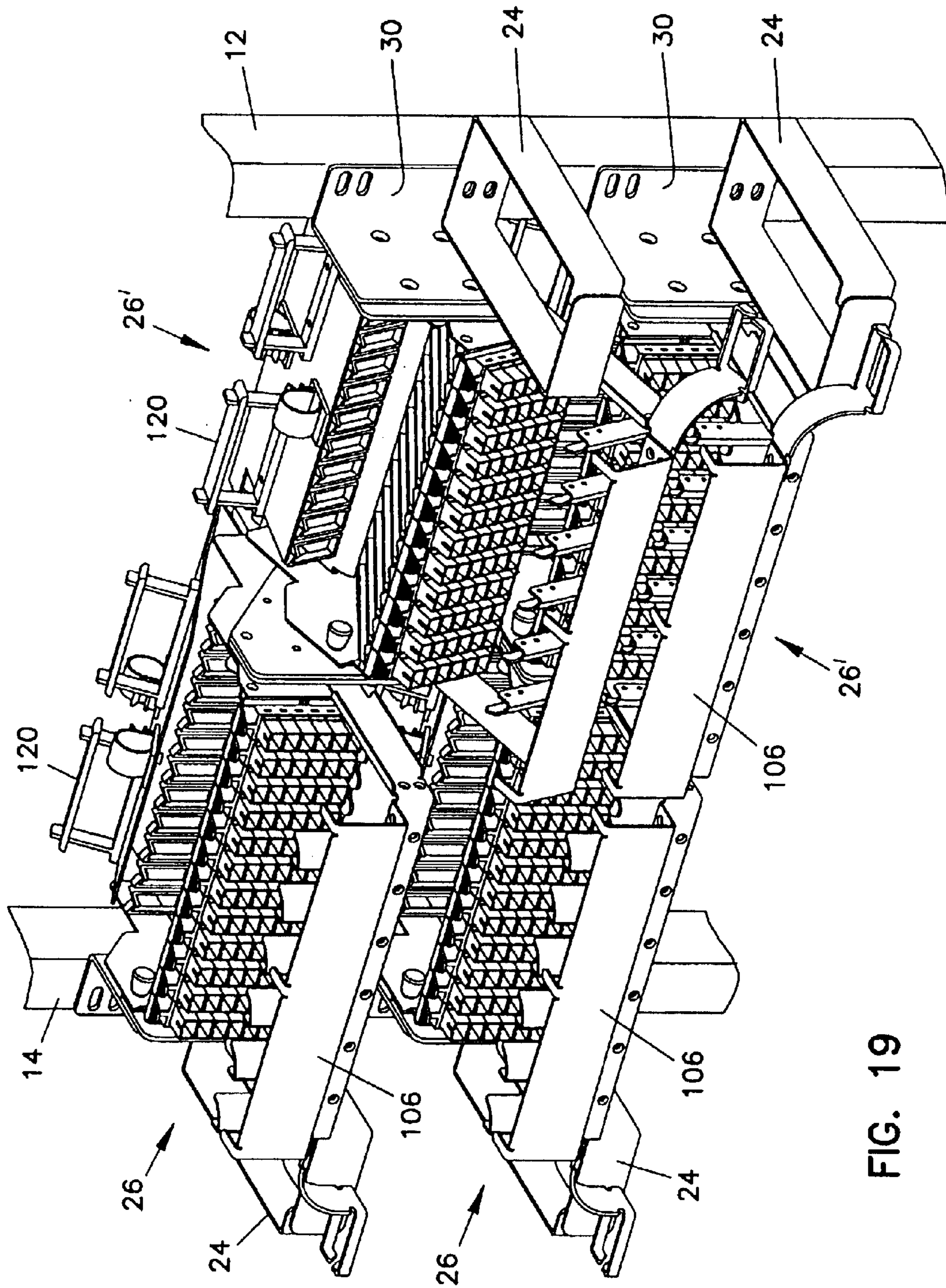

FIG. 19

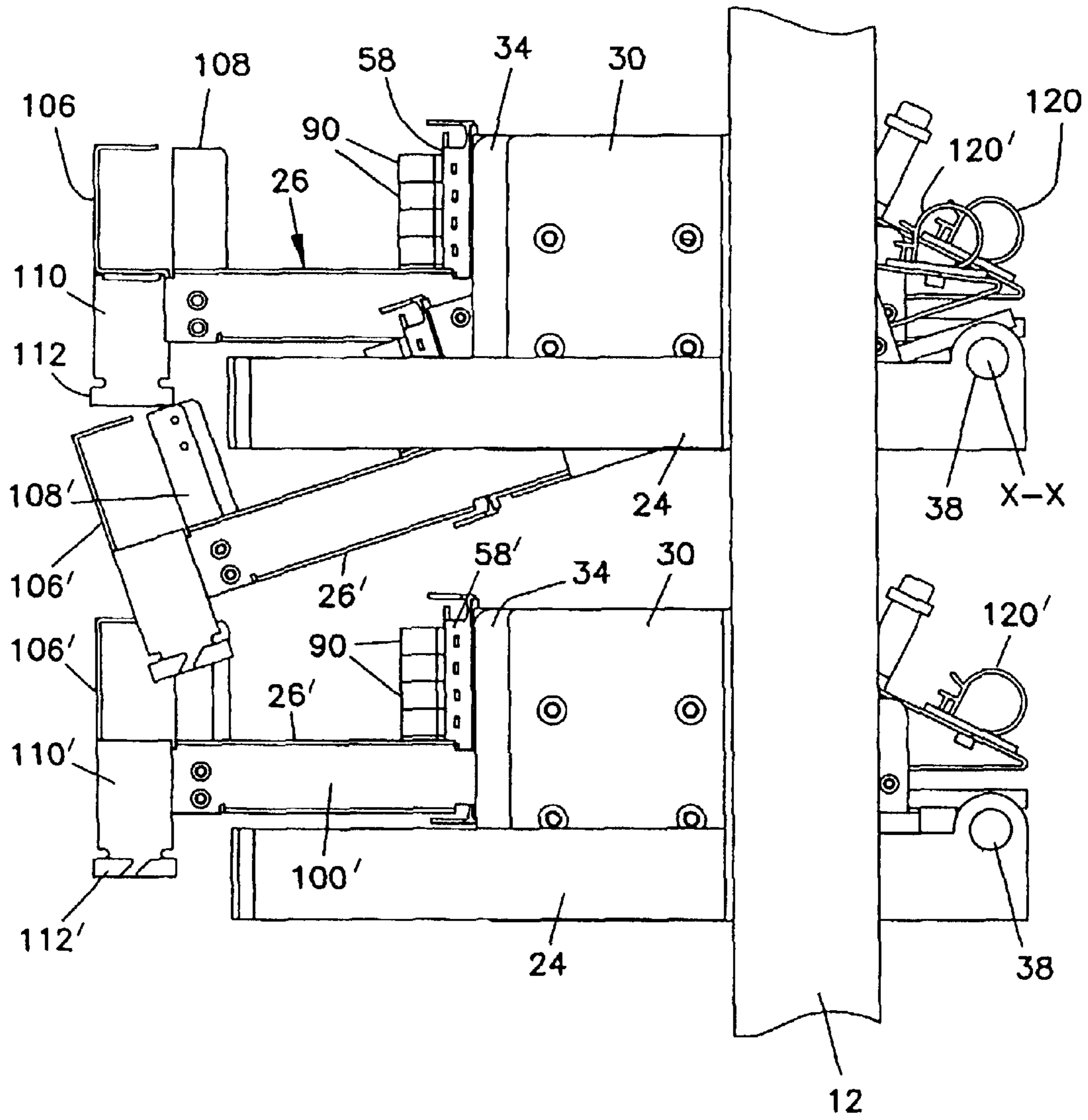

FIG. 20

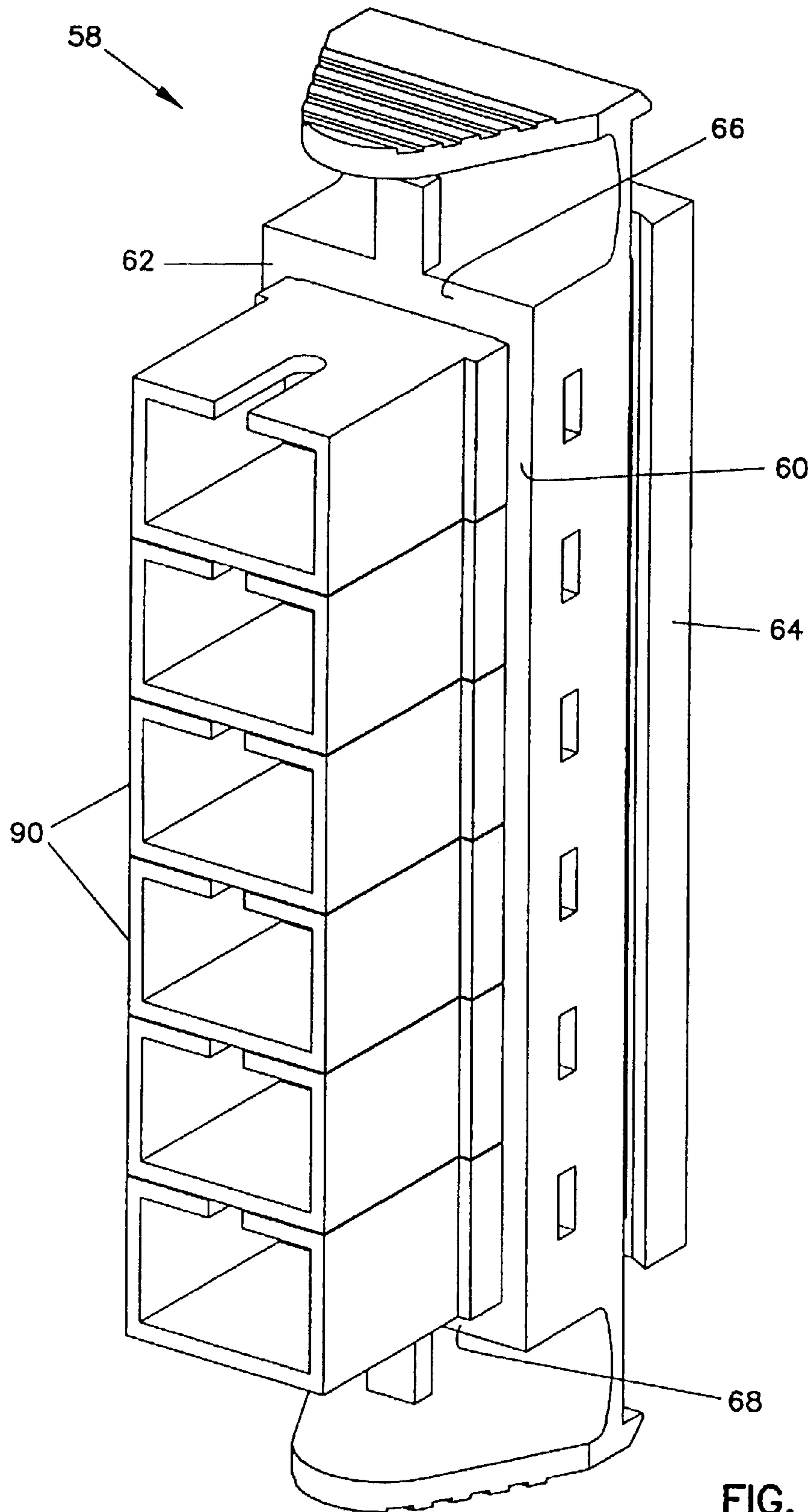

FIG. 21

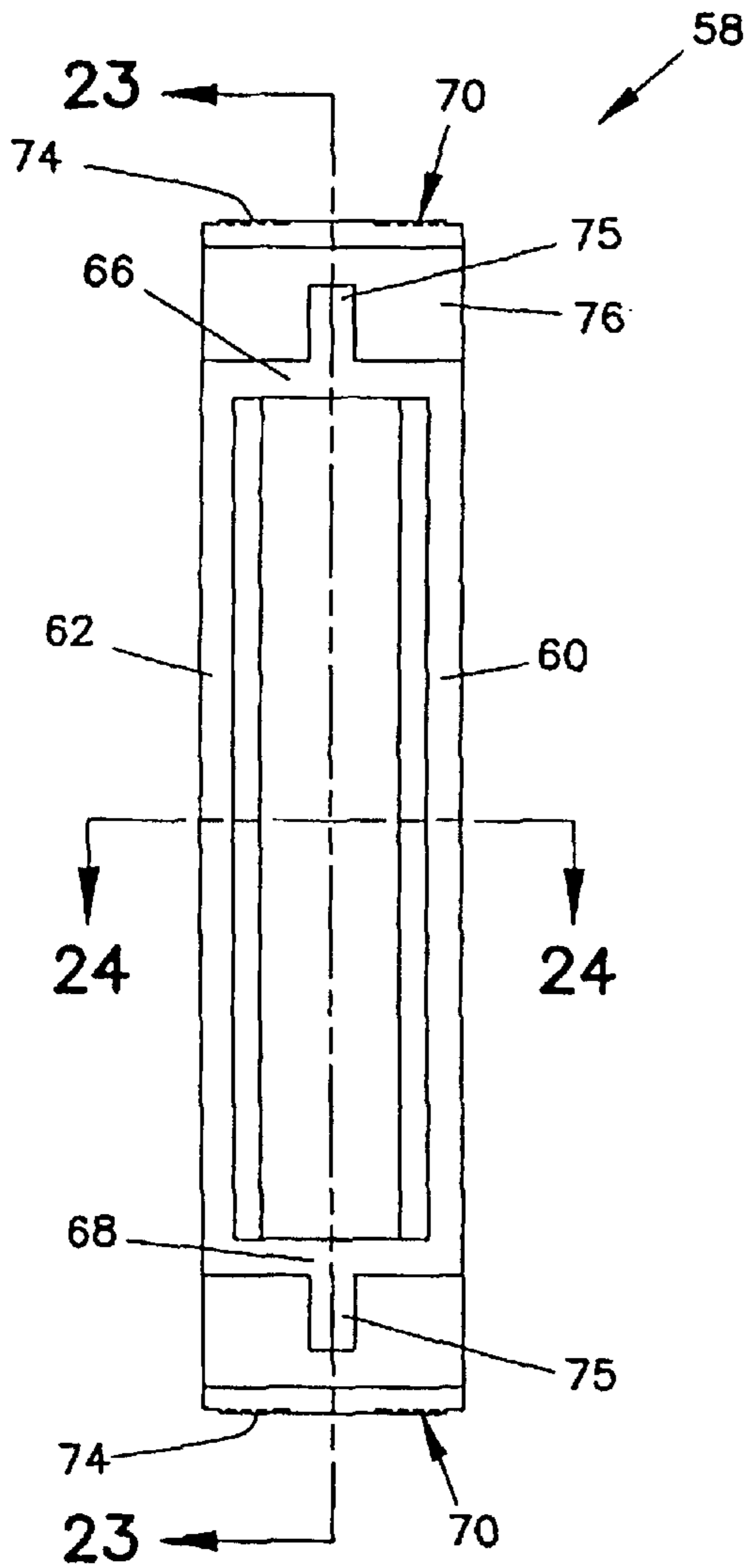

FIG. 22

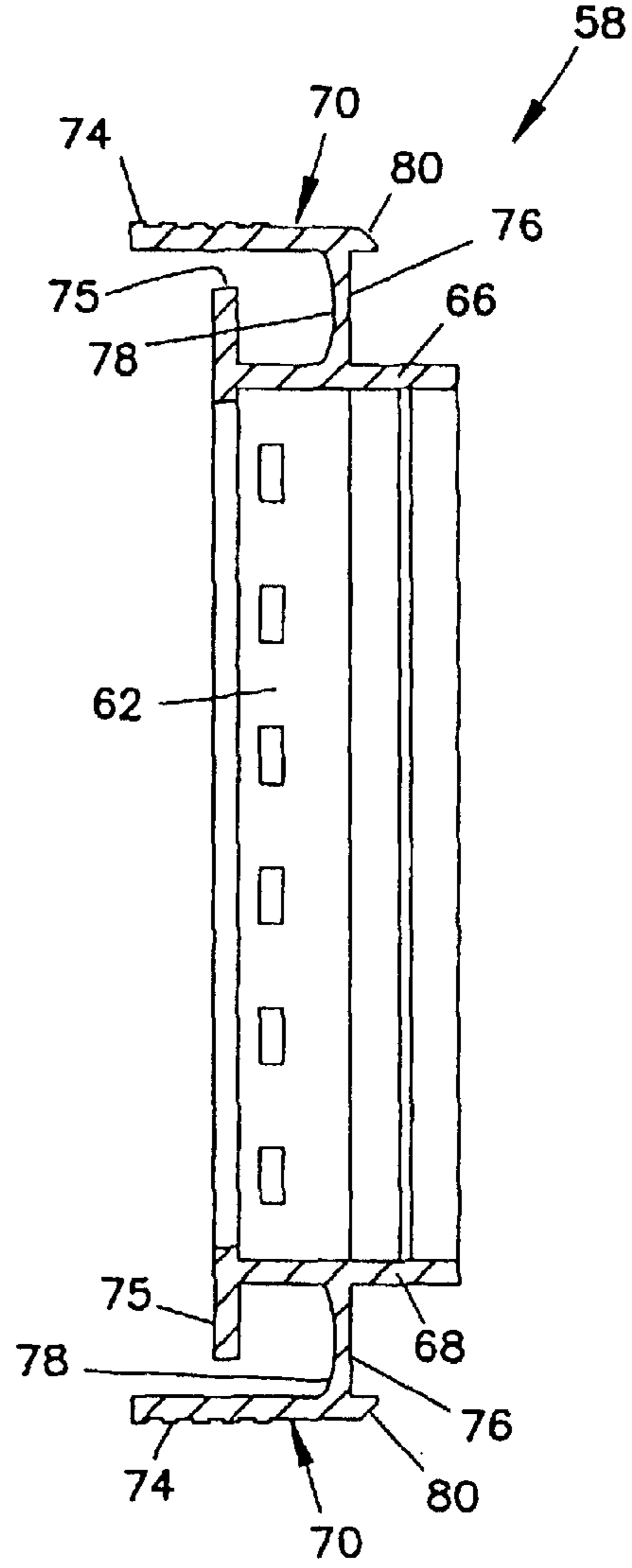

FIG. 23

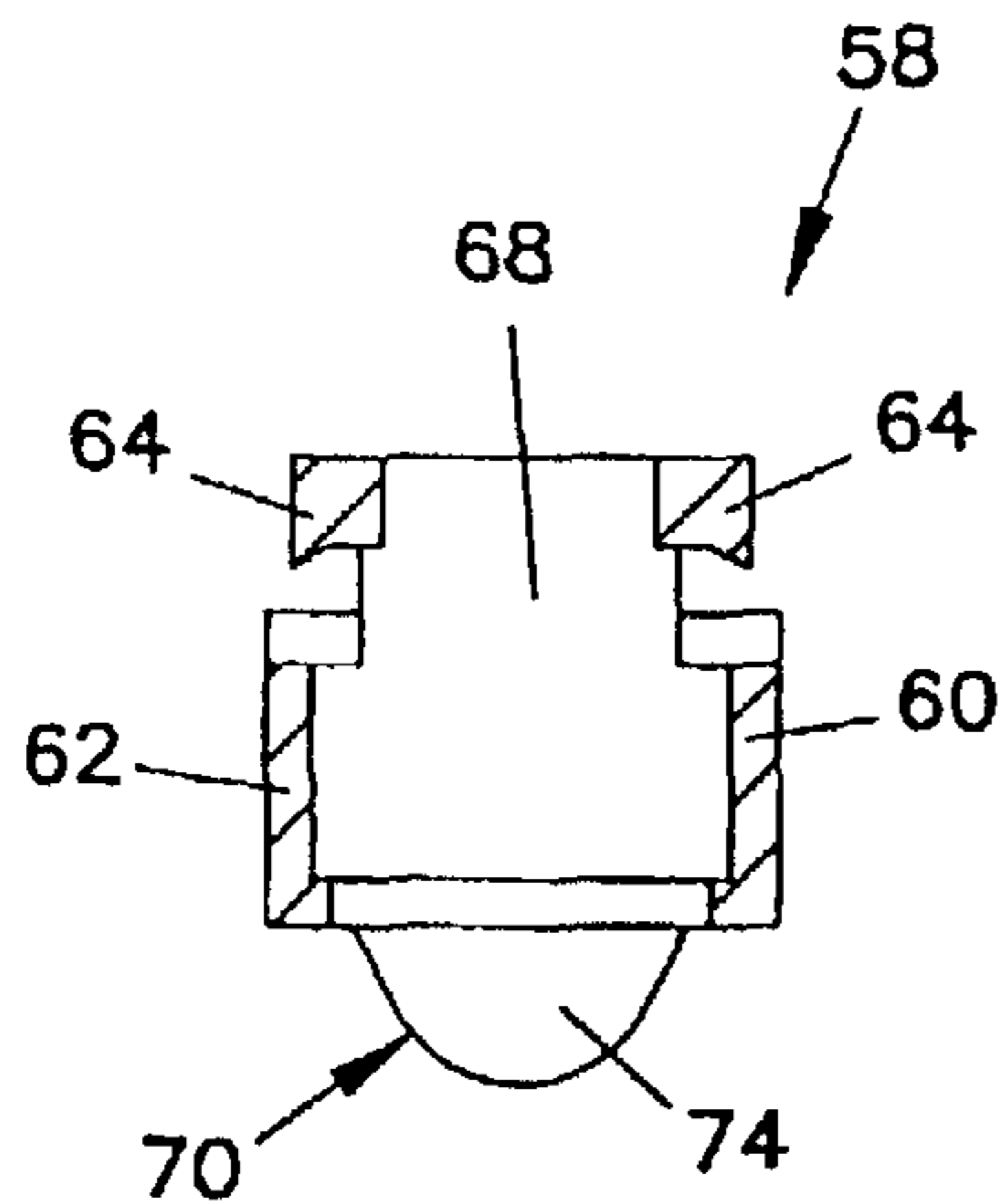

FIG. 24

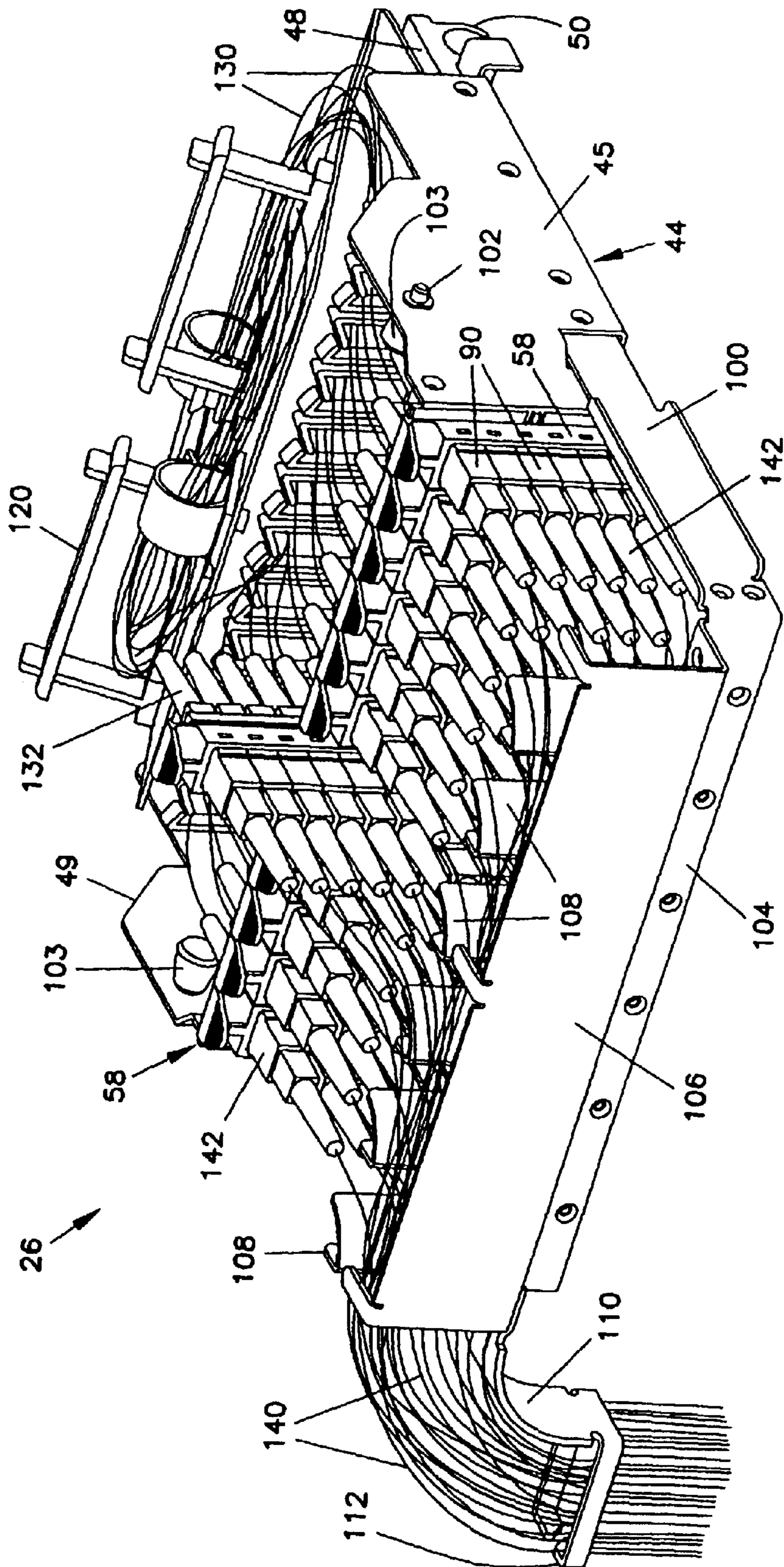
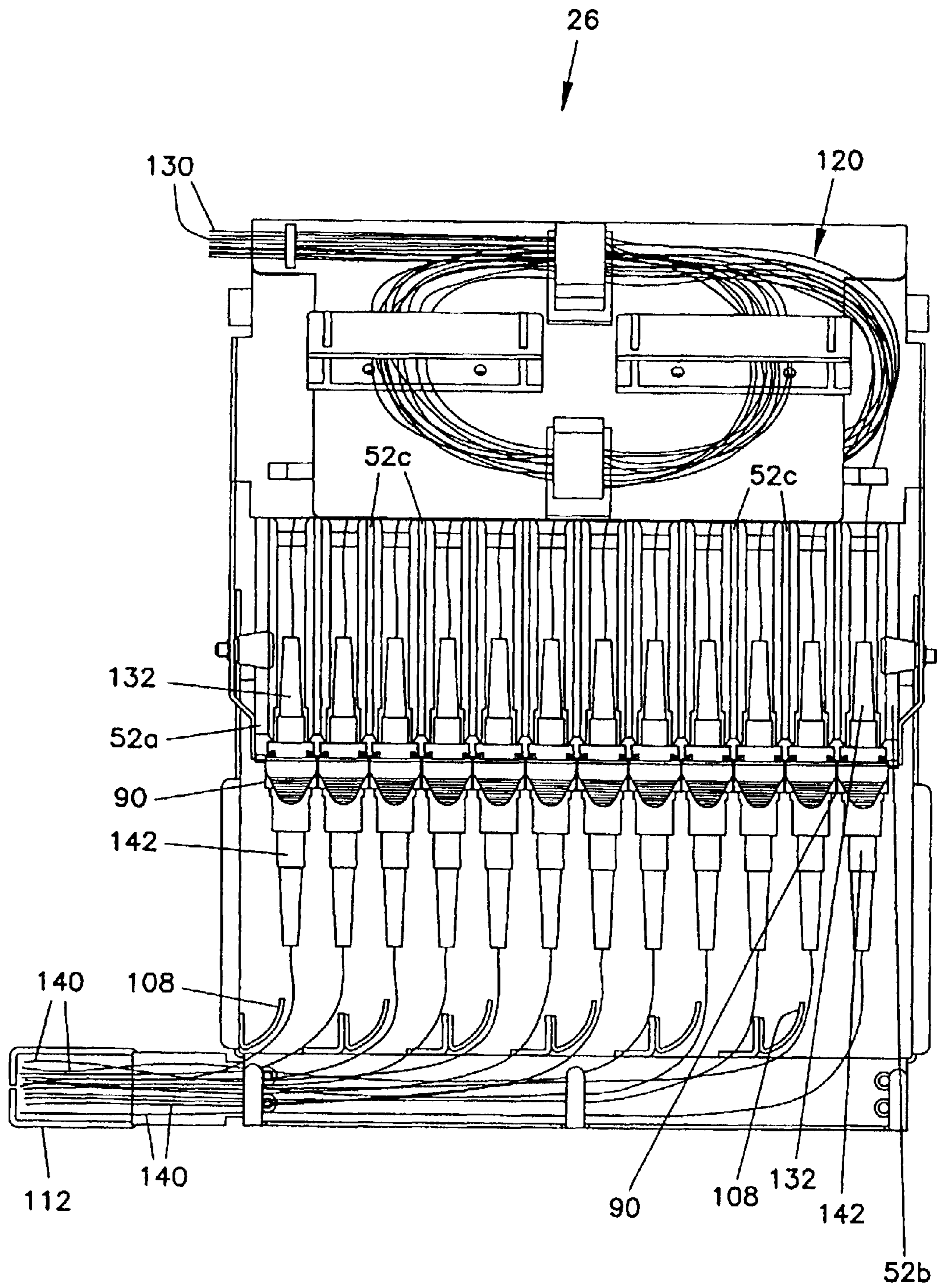

FIG. 25



HIGH-DENSITY FIBER DISTRIBUTION FRAME

Matter enclosed in heavy brackets [] appears in the original patent but forms no part of this reissue specification; matter printed in italics indicates the additions made by reissue.

CROSS-REFERENCE TO RELATED APPLICATIONS

[This] Notice: More than one reissue application has been filed for the reissue of U.S. Pat. No. 5,497,444. The reissue patent applications include the present application and U.S. patent application Ser. No. 09/035,377. The present application is a continuation of U.S. patent application Ser. No. 09/035,377. U.S. Pat. No. 5,497,444 is a continuation of application Ser. No. 08/180,970, filed Jan. 21, 1994, now abandoned.

BACKGROUND OF THE INVENTION

1. Field of the Invention

This invention pertains to the telecommunications industry. More particularly, this invention pertains to a high-density fiber distribution frame for use in the telecommunications industry.

2. Description of the Prior Art

In the telecommunications industry, use of fiber optic cables for carrying transmission signals is rapidly growing. To interconnect fiber optic equipment, fiber distribution frames have been developed. An example of a prior art fiber distribution frame is shown in commonly assigned U.S. Pat. No. 4,995,688.

The fiber distribution frame of U.S. Pat. No. 4,995,688 includes a so-called connector module (item 16 in the '688 patent) having a front panel which carries a plurality of adapters (102). Each of the adapters (102) permits attachment of a fiber optic connector (100) to both sides of the adapter in order to optically connect two fiber optic cables.

Typically, the back side of the adapters (102) are provided with connectors secured to fiber optic cables. The cables are connected to various pieces of fiber optic equipment (such as, a fiber-to-copper convertor for converting DS-3 signals to optical signals).

The connections on the back side of the adapters are semi-permanent. Namely, while the connectors on the back side of the adapters can be easily removed, they are normally installed with the intent to maintain the connection of the connector to the rear side of the adaptor without frequent future changes to the connection. On the front side of the adaptor, the fiber optic connector is secured to a fiber cable (for example, a jumper cable) for cross-connecting to other pieces of optical equipment or to any other destination.

With the increase in use of fiber optic cables in the telecommunications industry, it is desirable to provide fiber distribution frames with increased density. By density, it is meant the number of locations per unit volume or unit area for providing connection on the fiber distribution frame.

In products made according to the aforementioned U.S. Pat. No. 4,995,688, a typical fiber distribution frame will have about 576 fiber optic connector locations. In the industry, it is becoming desirable to substantially increase the density to be in excess of 1,400 connectors per frame.

Examples of high-density fiber distribution frames include a frame marketed under the trademark of Fiber Manager by Northern Telecom and described in Northern Tele-

com Bulletin No. 91-004, Issue No. 2, May, 1991. Another example includes the High Density Interconnect System (HDIC) of AT&T as disclosed in its Product Bulletin 2987D-DLH-7/89, Issue 2.

One problem associated with prior art high-density fiber distribution frames is that the prior art products require substantial displacement of fibers when access to the fiber connectors is required. For example, the Northern Telecom product houses the fibers and connectors in a molded plastic cassette. The cassette is shown on page 7 of the aforementioned Northern Telecom publication. The particular cassette shown has twelve connectors (paired into six connections). To access any one of the twelve connectors, the cassette must be pulled from the frame approximately three to four inches at which point the cassette drops to an access position as shown on page 6 of the aforementioned bulletin. As a result, even though only one connector may require access, a total of twelve connectors are displaced with substantial displacement of the fiber optic cables associated with each of the twelve connectors.

Unnecessary or excessive displacement of fiber optic cables is undesirable. As fiber optic cables are displaced, they are subject to bending and other forces. As a fiber bends, the fiber can break resulting in loss of transmission through the fiber. Since fibers carry extremely high signal rates, the breakage of a single fiber can result in a substantial loss of data or voice communications. Telecommunications industry standards generally recognize a minimum bending radius of about one and a half inches for optical fibers.

It is an object of the present invention to provide a fiber distribution frame which permits high density, ready access to fiber optic connectors and minimal displacement of fibers when access is being made to connectors.

SUMMARY OF THE INVENTION

According to a preferred embodiment of the present invention, a cable management system is provided which includes a fixture having a plurality of modules mounted on the fixture. Each of the modules is moveable on the fixture for movement along a line of travel. A releasable lock mechanism is provided for releasably locking each of the modules in a plurality of fixed positions along the line of travel. A plurality of mating elements is secured to each of the modules for movement therewith. The mating elements each includes means for connecting a first signal transmission cable at a rear side of the element with a second signal transmission cable at a front side of the element.

BRIEF DESCRIPTION OF THE DRAWINGS

FIG. 1 is a front, top and right side perspective view of a frame according to the present invention;

FIG. 2 is a top, front and right side perspective view of two mounting fixtures according to the present invention enjoined by common mounting bracket;

FIG. 3 is a top plan view of the mounting fixtures of FIG. 2;

FIG. 4 is a view similar to FIG. 2 showing a right mounting fixture pivoted to a down position;

FIG. 5 is a top, front and right side perspective view of a left mounting fixture removed from a mounting bracket;

FIG. 6 is a right side elevation view of the mounting fixture of FIG. 5;

FIG. 7 is a front, top and right side perspective view of a cross-connect tray including adapters;

FIG. 8 is a front, top and right side perspective view of a metallic support platform;

3

FIG. 9 is a front, top and right side perspective view of a left retaining wall;

FIG. 10 is a right side elevation view of the wall of FIG. 9;

FIG. 11 is an enlarged top plan view of a forward end of the wall of FIG. 9;

FIG. 12 is a front, top and right side perspective view of an intermediate retaining wall;

FIG. 13 is a right side elevation view of the wall of FIG. 12;

FIG. 14 is an enlarged top plan view of a forward end of the wall of FIG. 12;

FIG. 15 is a rear, top and left side perspective view of a right retaining wall;

FIG. 16 is a left side elevation view of the wall of FIG. 15;

FIG. 17 is a top plan view of a forward end of the wall of FIG. 15;

FIG. 18 is a view similar to FIG. 7 showing connector modules shifted;

FIG. 19 is a front, top and right side perspective view of four mounting fixtures mounted in a frame with an upper right side fixture pivoted to a down position;

FIG. 20 is a side right elevation view of the view of FIG. 19;

FIG. 21 is a front, top and right side perspective view of a connector module according to the present invention;

FIG. 22 is a front elevation view of the connector module of FIG. 21;

FIG. 23 is a view taken along lines 23—23 of FIG. 22;

FIG. 24 is a view taken along lines 24—24 of FIG. 22;

FIG. 25 is a front, top and right side perspective view of a fixture according to the present invention and connected to fiber optic cables and;

FIG. 26 is a top plan view of the fixture of FIG. 25.

DESCRIPTION OF THE PREFERRED EMBODIMENT

With reference now to the several drawing figures in which identical elements are numbered identically throughout, a description of the preferred embodiment of the invention will now be provided.

With initial reference to FIG. 1, a fiber distribution frame 10 is shown. The frame 10 includes spaced-apart side walls 12,14 connected at their upper ends by a top wall 16. Connected to the forward side of the top wall 16 is a trough 18 for carrying cables and the like as is conventional. The bottom of the frame 10 is provided with a pedestal 20 which also has secured to it a trough 22 for carrying cables and the like. The forward edges of the side walls 12,14 are provided with a plurality of clips 24 for holding fiber optic cables extending vertically in front of side walls 12,14.

Contained within frame 10 between side walls 12,14 are a plurality of left and right mounting fixtures 26,26' (schematically shown in FIG. 1). A detailed description of mounting fixtures 26,26' is provided elsewhere in this specification. The fixtures 26,26' are mounted to be aligned in two columns of ten fixtures per column with the two columns in horizontal alignment. It will be appreciated that the specific number of fixtures 26,26' and their alignment is shown for the purposes of illustrating a preferred embodiment and a different number and alignment of fixtures can be provided within a frame 10.

The fixtures 26,26' are illustrated in FIG. 2 with the fixtures 26,26' paired in a common mounting bracket 28. The

4

mounting bracket 28 includes first and second mounting plates 30,32 for attachment to walls 12,14 respectively. First fixed plates 34,36 are secured to each of mounting plates 30,32, respectively, with the fixed plates 34,36 disposed in parallel, spaced-apart alignment and connected by a pivot rod 38. Second fixed plates 40,42 (best shown in FIG. 4) are also fixedly secured to the pivot rod 38 with plates 40,42 disposed intermediate between plates 34,36 and parallel thereto. Plate 40 opposes plate 34 and plate 42 opposes plate 36.

A left fixture 26 is separately shown in FIG. 5. Except as will be specifically discussed, fixtures 26,26' are identical and a description of one will suffice as a description of the other. Elements of fixture 26' corresponding to elements of fixture 26 are identically numbered with the addition of an apostrophe to distinguish the fixtures.

The fixture 26 includes a metallic support platform 44 and a plastic molded cross-connect tray 46. The support platform 44 is separately shown in FIG. 8 and includes parallel side walls 45,49 spaced apart by a floor portion 47. A leading edge of the floor portion 47 is provided with parallel cut-outs 51 to define a plurality of support fingers 53.

The cross-connect tray 46 is separately shown in FIGS. 7 and 18. The cross-connect tray 46 includes a flat base 48 (which is secured to floor 47 of platform 44). Intricately molded with base 48 at a rear edge thereof are clips 50 sized to snap fit onto pivot rod 38 permitting clips 50 (and hence cross-connect tray 46) to rotate or pivot about the axis (X—X in FIG. 2) of the pivot rod 38. Pivot rod 38 and axis X—X are horizontal when the mounting fixture 26 is secured within the frame 10.

The upper surface of the base 48 is provided with a plurality of triangular-shaped walls including a left wall 52a, a right wall 52b and a plurality of intermediate walls 52c. The walls 52a—52c are numbered and shown assembled in FIG. 26 and are shown separately in FIGS. 9—17.

A wall is mounted on each support finger 53. The plurality of walls 52a—52c are vertical when base 48 is horizontal and each extends generally perpendicular to the pivot axis X—X of clips 50 with the walls 52a—52c disposed in spaced-apart, parallel alignment. Accordingly, opposing surfaces of each of the walls 52a—52c define a plurality of discrete channels 54. (FIG. 18). Also, opposing surfaces of each of the walls 52a—52c have formed therein parallel spaced-apart grooves 56 which extend perpendicular to the base 48.

Disposed within each of the channels 54 is a module 58. As best shown in FIGS. 21—24, each of modules 58 is a generally box-like construction including side walls 60,62. Each of side walls 60,62 is provided with a projecting rail 64 sized to be sideably received within grooves 56. Accordingly, rails 62,64 are received within grooves 56 to permit individual movement of each of the modules 58 relative to the platform 48 only in a direction of travel A (FIG. 18) which is perpendicular to the pivot axis X—X of the clips 50. The direction of travel A is vertical when base 48 is horizontal.

The rails 64 have beveled edges which taper inwardly toward the side walls 60,62. The groove 56 are complementary shaped. Accordingly, when rails 64 are received within the grooves 56, the rails can only move in the direction of the grooves 56. This structure provides lateral support to the walls 52a—52c.

The modules 58 further include top and bottom walls 66,68 which are provided with a releasable lock mechanism 70 for independently locking each of the modules 58 in any one of a plurality of fixed positions along the line of travel A.

5

The lock mechanisms 70 include tabs 74 secured to the walls 66,68 by hinge members 76. It will be appreciated that each of modules 58 is formed from an injection-molded plastic. The hinge member 76 is provided with a narrowed mid-point 78 (FIG. 23) to permit the material of the hinge member 76 to rotate about the mid-point 78 when an operator grasps the tab 74 and urges it toward the walls 66,68. The tabs 74 are also provided with a rear edge 80 (FIG. 23) which projects rearwardly from the hinge members 76. Further, a stop 75 is provided on each of walls 66,68 to limit the stroke of tabs 74 to prevent breakage of narrowed mid-point 78.

The lock mechanisms 70 are sized such that the rear edges 80 oppose and abut the top and bottom edges 82 of the wall members 52a-52c when the modules 58 are in a first or neutral position as shown in FIG. 7. In this position, the lock members 74 are shown biased to a lock position with the rear edges 80 opposing and abutting the top and bottom edges 82 to prevent movement of the modules 58 along the line of travel A.

By pressing on the tabs 74 and urging them toward the top and bottom walls 56,68. The lock mechanisms 70 are moved from their locked position to an unlocked position with the rear edges 80 clear of the top and bottom edges 82. So cleared, the modules 58 may be individually moved either up or down (i.e., in the direction of the line of travel A as shown in FIG. 18). Centrally positioned between the top and bottom edges 82 on each of walls 52a-52c are grooves 84,85. When either of the lock mechanisms 70 is in the region of the groove 84,85, an operator may release the lock mechanism 70 such that its natural bias causes the edge 80 to be received within the grooves 84,85. Accordingly, each of the modules 58 may be locked in an up position (with edge 80 of the lower lock mechanism 70 received within lower groove 85) or in a down position (with edge 80 of the upper lock mechanism 70 received within upper groove 84).

Each of modules 58 has a hollow construction which in a preferred embodiment is sized to receive six fiber optic connector adapters disposed in an abutting linear array. In the preferred embodiment shown, the specific adapters 90 are well-known and so-called SC adapters for receiving and retaining SC connectors at opposite ends of each of the adapters 90 such that each adaptor 90 joins and optically couples two fiber optic connectors.

It will be appreciated that SC adapters form no part of this invention per se. Such adapters are commercially available, well-known items. An example of such an adaptor is shown in commonly-assigned and co-pending U.S. Pat. application Ser. No. 08/065,139, filed May 30, 1993. Also, it will be appreciated that while SC adapters 90 are shown in use in a preferred embodiment, different types of adapters for different types of fiber optic connectors (for example, FC, D4 or other connectors) could also be utilized in the modules 58 with internal geometry of the modules 58 simply modified to accommodate different external geometry of different connector adapters.

With reference now back to FIGS. 4 and 5, each of the cross-connect trays 46 is secured (through bolts or the like) to the support platforms 44. Sidewalls 45, 49 of left fixture 26 are sized to closely face walls 42,36. Side walls 45' 49' of right fixture 26' are sized to closely face walls 34,40. The side walls 45,49 carry spring-loaded locking tabs 103 which can be pulled inwardly to retract a lock pin 102 (FIG. 5). Upon release of the tabs 103, the tabs 103 are spring-biased to permit locking pins 102 to protrude beyond the exterior of the side walls 45,49. Opposing surfaces of the plates 34,40, 42 and 36 are provided with detents 101 (FIG. 4) sized to

6

receive the pins 102 such that the support platform 44 and attached cross-connect trays 46 may be rotated about pivot rod 38 to any one of a plurality of rotated positions and fixed in place in the fixed position. FIG. 4 shows a mounting fixture 26 in a horizontal position and a second mounting fixture 26' rotated about pivot rod 38 to a down position.

The forward edge of each of the support platforms 44 is provided with extension side walls 100,102 which extend from the side plates 45,49. The extension walls 100,102 extend forwardly beyond the front side of the adapters 90 by a distance sufficient to permit connectors to be inserted within the adapters 90 as will become apparent.

The extension walls 100,102 are joined by a forward wall 104. Extending upwardly from forward wall 104 is a designation plate 106 which provides a flat surface generally parallel to the plane of the front ends of the adapters 90. The flat surface of the designation plate 106 provides a surface on which a designation strip can be attached to permit an operator to place identifying information or the like. The plate 106 also protects the adaptors 90 and attached connectors and fibers from physical damage.

Secured to the forward wall 104 and spaced between the designation plate 106 and the adapters 90 are a plurality of arcuate fanning clips 108. For the left side fixtures 26, the fanning clips 108 are arced to direct fibers from the adapters to the left side of the frame. For the right side fixture 26', the fanning clips 108 are oriented to direct fibers from the adapters 90 to the right side of the frame. Further, each of the fixtures 26 is provided with a radius plate 110 with an attached fanning clip 112. The plate 110 permits fibers to be draped downwardly through clip 112 with the radius 110 limiting the bending of the fibers to prevent excess bending.

Connected to the fixture 26 on the rear side thereof may be provided any one of a plurality of different styles of cable management fixtures 120. The cable management fixtures 120 shown in FIG. 4 includes a plurality of fanning clips for cable management as well as takeup spools for taking up excess amounts of cable. It will also be appreciated that the rear area of the fixtures 26 can be provided with a variety of different cable management devices including splice trays or the like.

With reference now to FIGS. 25-26, the reader will note use of the fixture 26 in use for organizing and cross connecting a plurality of optical fibers. Equipment fibers 130 enter the rear of the fixture 26 with excess fiber lengths wrapped around the cable management device 120. The equipment fibers 130 may originate from any one of a plurality of different types of fiber optic equipment such as fiber-to-copper convertors. Each of the fibers 130 is terminated at an SC connector 132. The connector 132 is received within the back end of adapters 90. Cross-connect fiber cables (frequently referred to as jumpers) 140 are passed through clip 112 and individually fanned by fanning clips 108 toward adapters 90. Each of the fibers 140 terminates at an SC connector 142 which is each received within the forward end of an adaptor 90 such that each one of connectors 132 is individually connected to a singular one of a plurality of connectors 142.

From time to time, it is desirable to replace or move the cross-connect cables 140. If the cables or connectors of the top three adaptors of a given module 58 are desired to be accessed, the operator grasps the locking tabs 74 and moves the module upwardly to the position of the raised module 58 shown in FIG. 25. In this position, each of the top three of the connectors 142 of the module is readily accessible without interference from the designation strip 106. If the bottom

three of the connectors **142** of the same module **58** are to be accessed, the operator simply engages the tabs **74** and moves the connector downwardly until the top tab **74** is received within the groove **84** to lock the module **58** in the down position. In the down position, the bottom three of the connectors **142** is accessible beneath the designation strip **106** without interference from the designation strip **106**. When no connectors are to be accessed, the module **58** is placed in its neutral position with all of the connectors **142** protected from impact or other interference by means of the designation strip **106** and the forward wall **104**.

The reader will note that in order to obtain access to any one of the connectors **142** in a module **58**, the module **58** is only moved a very small distance. Also, only six adaptors **90** are moved at a time. The very small movement associated with accessing each of the connectors results in a minimal probability of damage to any one of the fiber optic cables.

The benefits of the present invention include limited displacement of the fibers. In the prior art, when a tray containing several connectors is moved, the fibers are displaced axially by a substantial amount (e.g., about 3 inches). In the present invention, as a module **58** is moved up or down (about 1.5 inches) the fiber experiences very little axial movement with most of the movement accommodated by a lifting or lowering movement of the fiber transverse to the fiber's axis.

While the back connectors **132** are semi-permanently installed, it is desirable, from time to time, to be able to have access to the connectors **132** (particularly when the connectors **132** are initially installed). However, if access to back connectors **132** is desired, they may be accessed the same as the front connectors **142** (i.e., by raising or lowering modules **58**).

In certain installations, only the front of frame **10** is accessible to an operator. In such installations, access to the cable management device **120** is obtained through the tilt feature of the fixture **26**. Namely, to obtain access to the cable management device **120** from the front of frame **10**, the tabs **103** are pulled inwardly to retract lock pins **102**. With the pins **102** retracted, the entire fixture **26** rotates about the pivot rod **38** to a down position as shown by fixture **26'** in FIG. 4. In the down position, the cable management device **120** is readily accessible to an operator facing the front of the frame **10**.

Other modifications of the invention may be apparent to one skilled in the art. For example, in the preferred embodiment illustrated, a module **58** with all six adaptors **90** is moved up or down from the neutral position. Alternatively, the module **58** could be split in half with the top half moved up to access the top three connectors and with the bottom half independently moved down to access the bottom three adaptors.

Also, as an alternative, the modules **58** can be provided with additional functions. In the preferred embodiment illustrated, the modules **58** retain only adaptors **90**. However, modules **58** can include products other than adaptors **90**. For example, modules **58** may house optical splitters, WDM's (wave division multiplexers) or other equipment. While adaptors **90** may be used with such enhancements, adaptors **90** may not be necessary (e.g., such enhanced modules may be provided with fiber pigtailed).

From the foregoing detailed description of the present invention, it has been shown how the objects of the invention have been attained in a preferred manner. However, modifications and equivalents of the disclosed concepts, such as those which readily occur to one skilled in the art, are

intended to be included within the scope of the claims which are appended hereto.

What is claimed is:

[1. A signal transmission cable management system comprising:

a fixture;

a plurality of modules mounted on said fixture with each of said modules movably mounted on said fixture for movement along a line of travel, each one of said modules including a plurality of adaptor means for holding a fiber optic connector, each one of said adaptor means movable with said one of said modules along said line of travel;

releasable lock means for releasably locking each of said modules in any one of a plurality of fixed positions along said line of travel;

means for connecting a first signal transmission cable at a rear side of said module with a second signal transmission cable connected at a front side of said module.]

[2. A system according to claim **1** wherein said modules each have a longitudinal axis; said modules mounted on said fixture in side-by-side relation with said longitudinal axes generally parallel to said line of travel, said plurality of adaptor means linearly disposed along said longitudinal axis.]

[3. A system according to claim **1** wherein said fixture includes a plurality of spaced-apart walls, opposing pairs of said walls, defining a plurality of channels, each of said modules being disposed within a respective channel, cooperating guide means for each of said modules and said walls for attaching said modules to said walls and accommodating movement of each of said modules along said line of travel.]

[4. A system according to claim **1** wherein each of said plurality of fixed positions includes a first, second and third position, each linearly separated along said line of travel.]

[5. A system according to claim **1** comprising a frame having mounting means for mounting said fixture in said frame;

said mounting means including a pivot attachment for said fixture to pivot relative to said frame about said pivot axis.]

[6. A system according to claim **5** wherein said pivot axis is generally perpendicular to said line of travel.]

[7. A system according to claim **5** wherein said mounting means further includes a frame lock for releasably locking said fixture in any one of a plurality of a pivoted positions about said pivot axis.]

[8. A system according to claim **1** comprising a plurality of mating elements secured to each of said modules, said mating elements each including means for connection of said front side, respectively, with said first and second cables optically coupled.]

[9. A system according to claim **8** wherein said mating elements are mounted in a linear array defining a longitudinal axis for each of said modules, said modules mounted on said fixture in side-by-side relation with said longitudinal axes generally parallel to said line of travel.]

[10. A signal transmission cable management system comprising:

a fixture;

a plurality of modules mounted on said fixture with each of said modules movably mounted on said fixture for movement along a line of travel;

releasable lock means for releasably locking each of said modules in any one of a plurality of fixed positions along said line of travel, each of said plurality of fixed positions including a first, second and third position, each linearly separated along said line of travel;

9

means for connecting a first signal transmission cable at a rear side of said module with a second signal transmission cable connected at a front side of said module;

a forward wall disposed, spaced from and opposing said front sides of said modules said modules shielded by said forward wall when said one of said modules is in said first position and with a first upper portion of said one of said modules exposed above an upper edge of said forward wall when said one is in said second position and with a second portion of said one exposed below a lower edge of said forward wall when said one is in said third position.]

[11. A signal transmission cable management system comprising:

a fixture;

a plurality of modules mounted on said fixture with each of said modules movably mounted on said fixture for movement along a line of travel;

releasable lock means for releasably locking each of said modules in any one of a plurality of fixed positions along said line of travel;

means for connecting a first signal transmission cable at a rear side of said module with a second signal transmission cable connected at a front side of said module;

said fixture including a plurality of spaced-apart walls, opposing pairs of said walls, defining a plurality of channels, each of said modules being disposed within a respective channel, cooperating guide means for each of said modules and said walls for attaching said modules to said walls and accommodating movement of each of said modules along said line of travel;

said lock means including a locking member on each of said modules, said locking member moveable between a locked position and an unlocked position; said walls and said locking member including cooperating elements for restraining said modules for movement along said line of travel at each of said plurality of fixed positions when said locking member is in said locked position and accommodating movement of said module along said line of travel when said locked member is in said unlocked position.]

[12. A system according to claim 11 wherein said cooperating elements includes a detent formed in said walls and corresponding with said plurality of fixed positions, said locked member including an edge sized to be received within said detent when said lock member is in said locked position and said edge removed from said detent when said lock member is in said unlocked position.]

[13. A system according to claim 12 wherein said lock member is biased toward said locked position.]

[14. A signal transmission cable management system comprising:

a fixture;

a plurality of modules mounted on said fixture with each of said modules movably mounted on said fixture for movement along a line of travel;

releasable lock means for releasably locking each of said modules in any one of a plurality of fixed positions along said line of travel;

means for connecting a first signal transmission cable at a rear side of said module with a second signal transmission cable connected at a front side of said module;

10

said fixture including a plurality of spaced-apart walls, opposing pairs of said walls, defining a plurality of channels, each of said modules being disposed within a respective channel, cooperating guide means for each of said modules and said walls for attaching said modules to said walls and accommodating movement of each of said modules along said line of travel;

said cooperating guide means including a rail on each of said modules and a mating groove on at least one of said walls opposing each of said channels with said rails slidable received within said groove and with said rails sliding within said groove along said line of travel.]

[15. In a signal transmission cable management system having a fixture including a plurality of spaced apart walls defining a plurality of parallel spaced apart cavities, said walls including first and second parallel and opposing recesses; an optic module for mounting in said cavities, said module comprising:

a body sized to be slidably received within said cavity for movement along a line of travel, said body having first and second parallel rails, said rails sized to be slidably received within said recesses;

said body including a plurality of adaptor means for connecting a plurality of fiber optic cables to said body, said plurality of adaptor means linearly aligned along said line of travel;

said body including latch means for securing said body to said fixture in any one of a plurality of fixed positions along said line of travel.]

16. A cable management system, comprising:

(a) a fixture; and

(b) a module moveably mounted on the fixture for movement along a line of travel, the module including a plurality of adaptor means for holding a fiber optic connector, each one of the adaptor means movable with the module along the line of travel; the plurality of adaptor means being disposed in a linear array parallel to the line of travel.

17. The cable management system of claim 16, further including:

(a) releasable lock means for releasably locking the module in a fixed position, the releasable lock means having a locked position and an unlocked position.

18. The cable management system of claim 17, wherein:

(a) the module is secured in the fixed position when the releasable lock means is in the locked position; and

(b) the module is moveable along the line of travel when the releasable lock means is in the unlocked position.

19. The cable management system of claim 17, wherein:

(a) the releasable lock means includes a tab member that pivots from the locked position to the unlocked position.

20. The cable management system of claim 16, further including:

(a) a plurality of modules, each module being moveably mounted to the fixture along a line of travel.

21. The cable management system of claim 16, further including:

(a) mounting structure having a groove construction configured to slideably receive a rail structure of the module to provide movement of the module along the line of travel.

11

22. A cable management system, comprising:

(a) a fixture;

(b) a plurality of modules moveably mounted on the fixture for movement along a line of travel, each of the modules including an adaptor for holding a fiber optic connector, the adaptor being movable with the module along the line of travel, the line of travel being transverse to a central axis extending between front and rear ends of the fiber optic connector when the fiber optic connector is held by the adaptor; and

(c) cooperating guide means for attaching the modules to the fixture and accommodating movement of each of the modules along the line of travel, the cooperating guide means including a first wall and a second opposite wall, the first and second walls including structure that defines a portion of the cooperating guide means.

23. The cable management system of claim 22, wherein:

(a) at least one of the plurality of modules is positioned between the first and second walls.

24. The cable management system of claim 22, wherein:

(a) the cooperating guide means includes a first rail mounted on the module and a first mating groove on one of the first and second walls to slideably received the first rail of the module.

25. The cable management system of claim 24, wherein:

(a) the cooperating guide means includes a second rail mounted on the module and a second mating groove on the other of the first and second walls to slideably received the second rail of the module.

12

26. A cable management system, comprising:

(a) a fixture;

(b) a plurality of modules moveably mounted on the fixture for movement along a line of travel, each of the modules including an adaptor for holding a fiber optic connector, the adaptor being movable with the module along the line of travel, the line of travel being transverse to a central axis extending between front and rear ends of the fiber optic connector when the fiber optic connector is held by the adaptor;

(c) releaseable lock means for releaseably locking each of the plurality of modules in a fixed position, the releaseable lock means having a locked position and an unlocked position; and

(d) cooperating guide means for attaching the modules to the fixture and accommodating movement of each of the modules along the line of travel.

27. The cable management system of claim 22, wherein each of the modules includes a plurality of adaptors for holding fiber optic connectors, the plurality of adaptors being movable with the module along the line of travel.

28. The cable management system of claim 26, wherein each of the modules includes a plurality of adaptors for holding fiber optic connectors, the plurality of adaptors being movable with the module along the line of travel.

* * * * *

UNITED STATES PATENT AND TRADEMARK OFFICE
CERTIFICATE OF CORRECTION

PATENT NO. : RE41,460 E
APPLICATION NO. : 10/391052
DATED : July 27, 2010
INVENTOR(S) : Wheeler

Page 1 of 1

It is certified that error appears in the above-identified patent and that said Letters Patent is hereby corrected as shown below:

Title page, Item (63) U.S. Application: "Continuation of application No. 08/180,970, filed on Jan. 21, 1994, now abandoned." should read --Continuation of application No. 09/035,377, filed on Mar. 5, 1998, now U.S. Patent No. RE38,311. U.S. Patent No. 5,497,444 is a continuation of application No. 08/180,970, filed on Jan. 21, 1994, now abandoned.--

Signed and Sealed this
Twenty-second Day of November, 2011

A handwritten signature in black ink that reads "David J. Kappos". The signature is written in a cursive, slightly slanted style.

David J. Kappos
Director of the United States Patent and Trademark Office

UNITED STATES PATENT AND TRADEMARK OFFICE
CERTIFICATE OF CORRECTION

PATENT NO. : RE41,460 E
APPLICATION NO. : 10/391052
DATED : July 27, 2010
INVENTOR(S) : Todd A. Wheeler

Page 1 of 1

It is certified that error appears in the above-identified patent and that said Letters Patent is hereby corrected as shown below:

Column 1, lines 11-18, below the heading, "CROSS-REFERENCE TO RELATED APPLICATIONS", should read: --Notice: More than one reissue application has been filed for the reissue of patent 5,497,444. The reissue applications are application nos. 12/930,087, which is a continuation of 12/804,078, which is a continuation of 10/391,052, now Patent No. RE41,460, which is a continuation of 09/035,377, now Patent No. RE38,311, all of which are reissue applications of Patent No. 5,497,444.--

Signed and Sealed this
Twenty-fifth Day of September, 2012

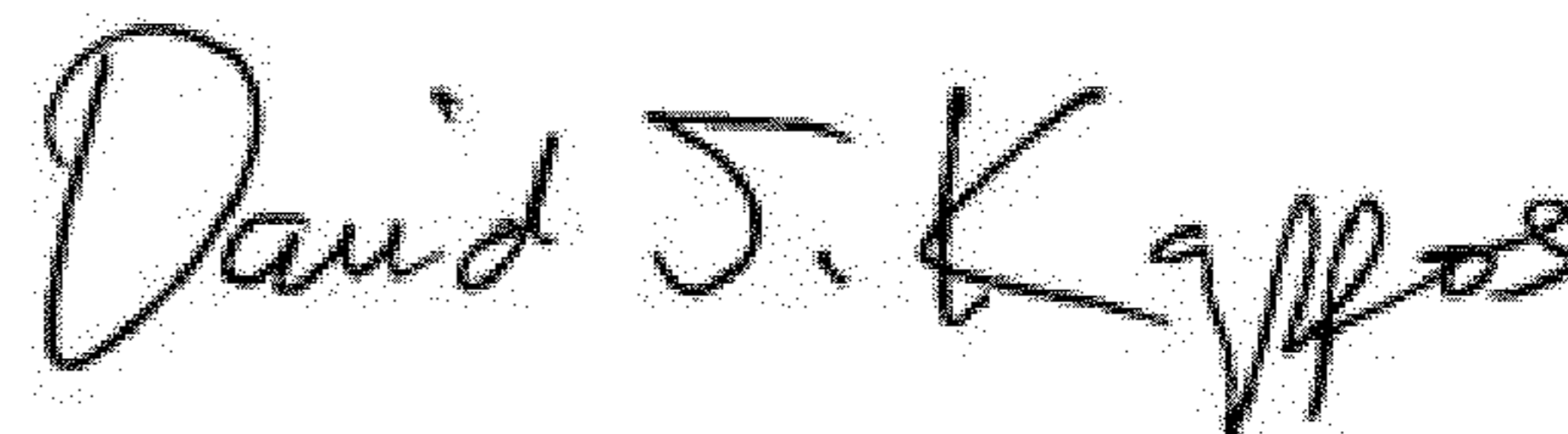

David J. Kappos
Director of the United States Patent and Trademark Office