

US00RE41409E

(19) **United States**  
(12) **Reissued Patent**  
**Jürs et al.**

(10) **Patent Number:** **US RE41,409 E**  
(45) **Date of Reissued Patent:** **Jun. 29, 2010**

(54) **DEVICE AND METHOD RESPECTIVELY FOR PROCESSING FLESH**

(56) **References Cited**

(75) Inventors: **Michael Jürs**, Haffkrug (DE); **Matthias Schroeder**, Badendorf (DE); **Conrad Torkler**, Zecher (DE)

(73) Assignee: **Nordischer Maschinenbau Rub Baader GmbH + CO KG**, Lubeck (DE)

(21) Appl. No.: **11/351,218**

(22) Filed: **Feb. 10, 2006**

**Related U.S. Patent Documents**

Reissue of:

(64) Patent No.: **6,843,714**  
Issued: **Jan. 18, 2005**  
Appl. No.: **10/606,958**  
Filed: **Jun. 27, 2003**

U.S. Applications:

(63) Continuation of application No. 09/744,519, filed as application No. PCT/EP99/05283 on Jul. 27, 1999, now Pat. No. 6,604,991.

(30) **Foreign Application Priority Data**

Jul. 31, 1998 (DE) ..... 198 34 524

(51) **Int. Cl.**  
**A22C 25/00** (2006.01)

(52) **U.S. Cl.** ..... **452/161**

(58) **Field of Classification Search** ..... 452/149, 452/150, 155-158, 161, 162, 170

See application file for complete search history.

U.S. PATENT DOCUMENTS

4,557,019 A	*	12/1985	Van Devanter et al.
4,875,254 A	*	10/1989	Rudy et al. .... 452/157
5,042,340 A	*	8/1991	Kasper ..... 83/73
5,184,733 A	*	2/1993	Arnarson et al. .... 209/585
5,324,228 A	*	6/1994	Vogeley, Jr. .... 452/158
5,580,306 A	*	12/1996	Young et al. .... 452/171
5,591,076 A	*	1/1997	Evers et al. .... 452/157

FOREIGN PATENT DOCUMENTS

DE	3239125 C1	*	10/1982
DE	3239125	*	10/1982
EP	266 441	*	5/1988
EP	288 592	*	11/1988
EP	429 711	*	6/1991
JP	1-202134	*	8/1989
SE	170906	*	11/1957

\* cited by examiner

*Primary Examiner*—Thomas Price

(74) *Attorney, Agent, or Firm*—Mattingly & Walur, P.C.

(57) **ABSTRACT**

A device for processing flesh includes at least one transport belt, at least one element for position detection as well as at least one separating device and at least one control device, wherein the separating device communicates via the control device with the element for position detection which provides information to be recorded and processed into geometric data of the flesh and image data of the flesh so that separating cuts based on the geometric and image data can be made with the separating device.

**12 Claims, 7 Drawing Sheets**

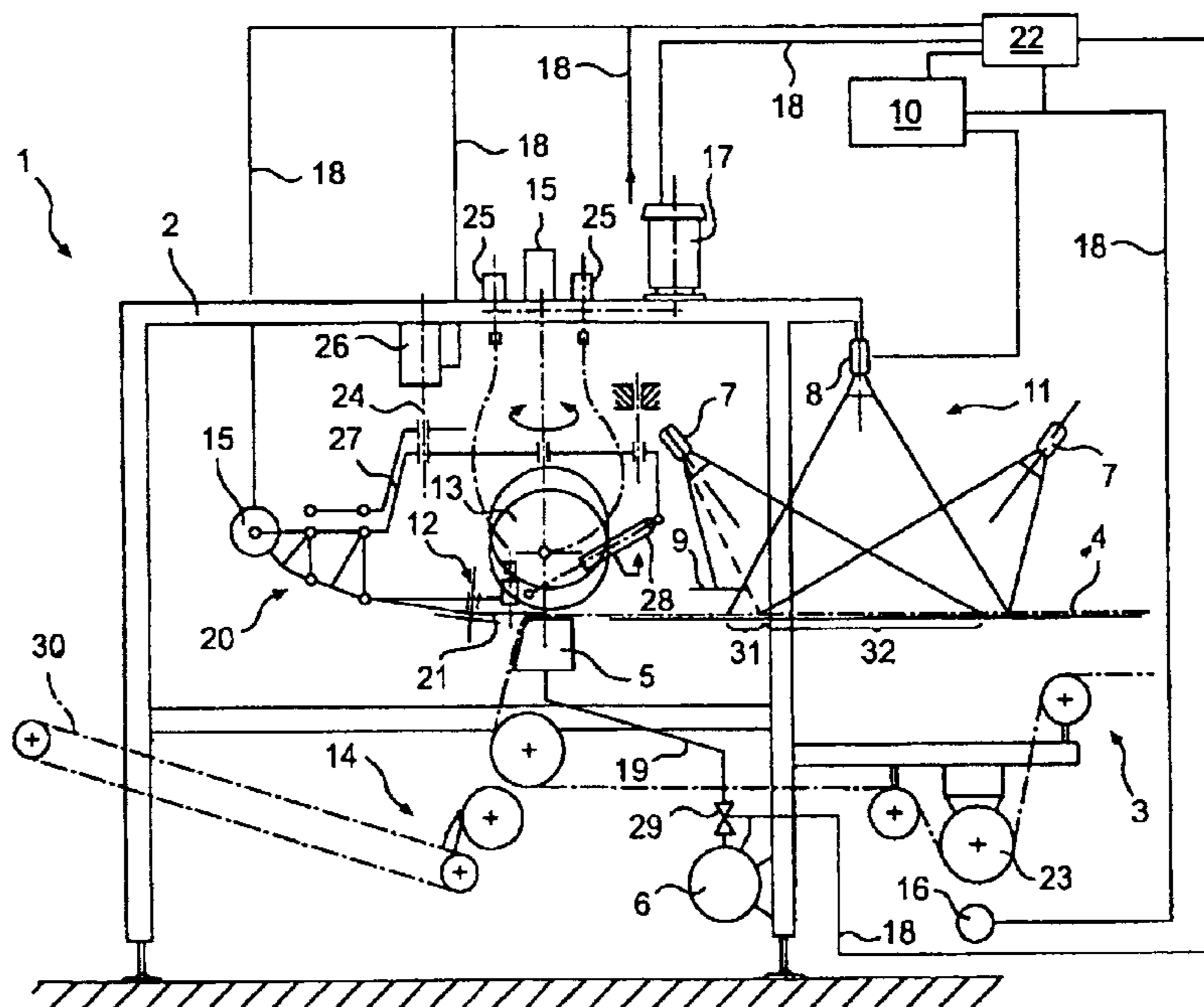

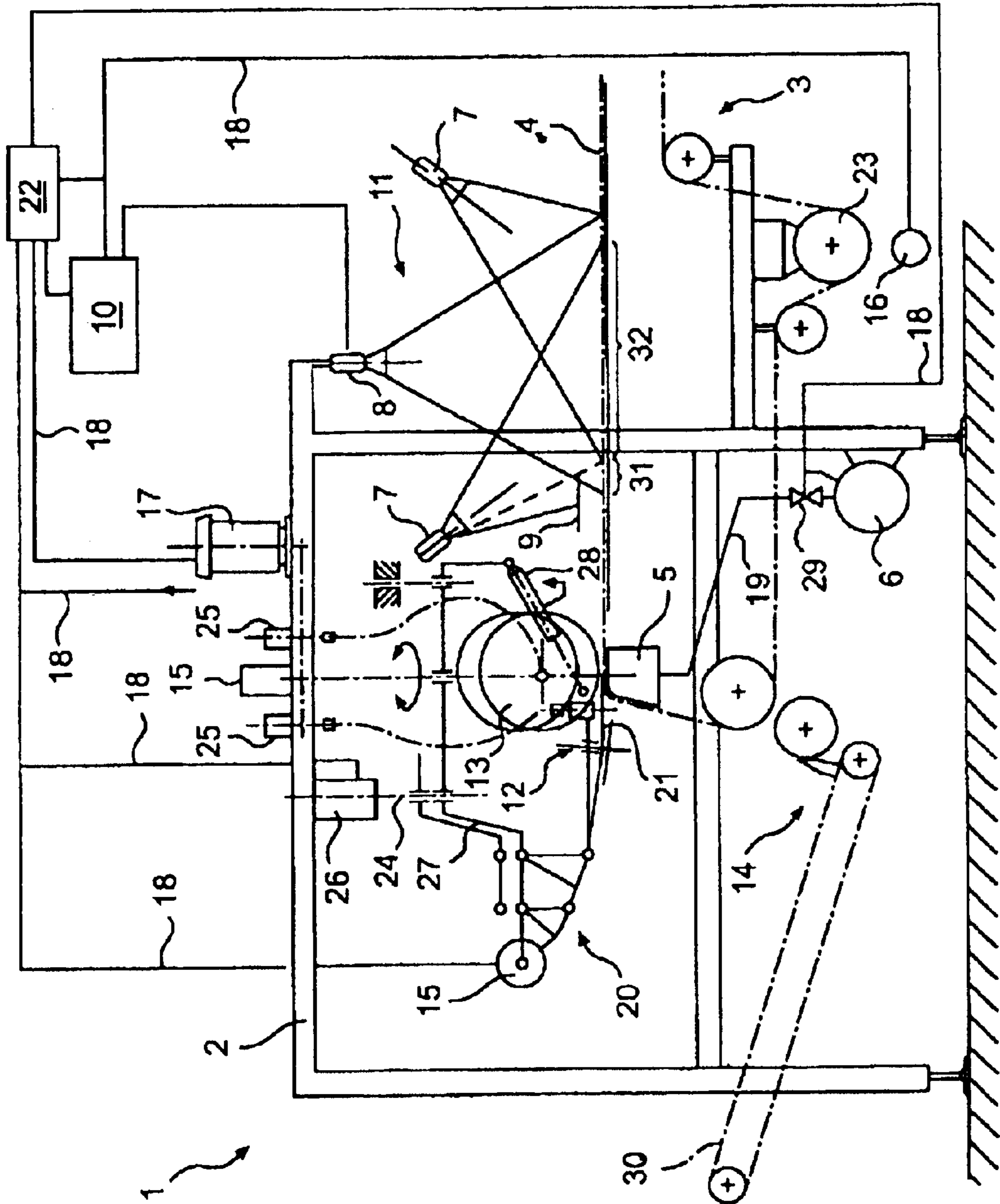
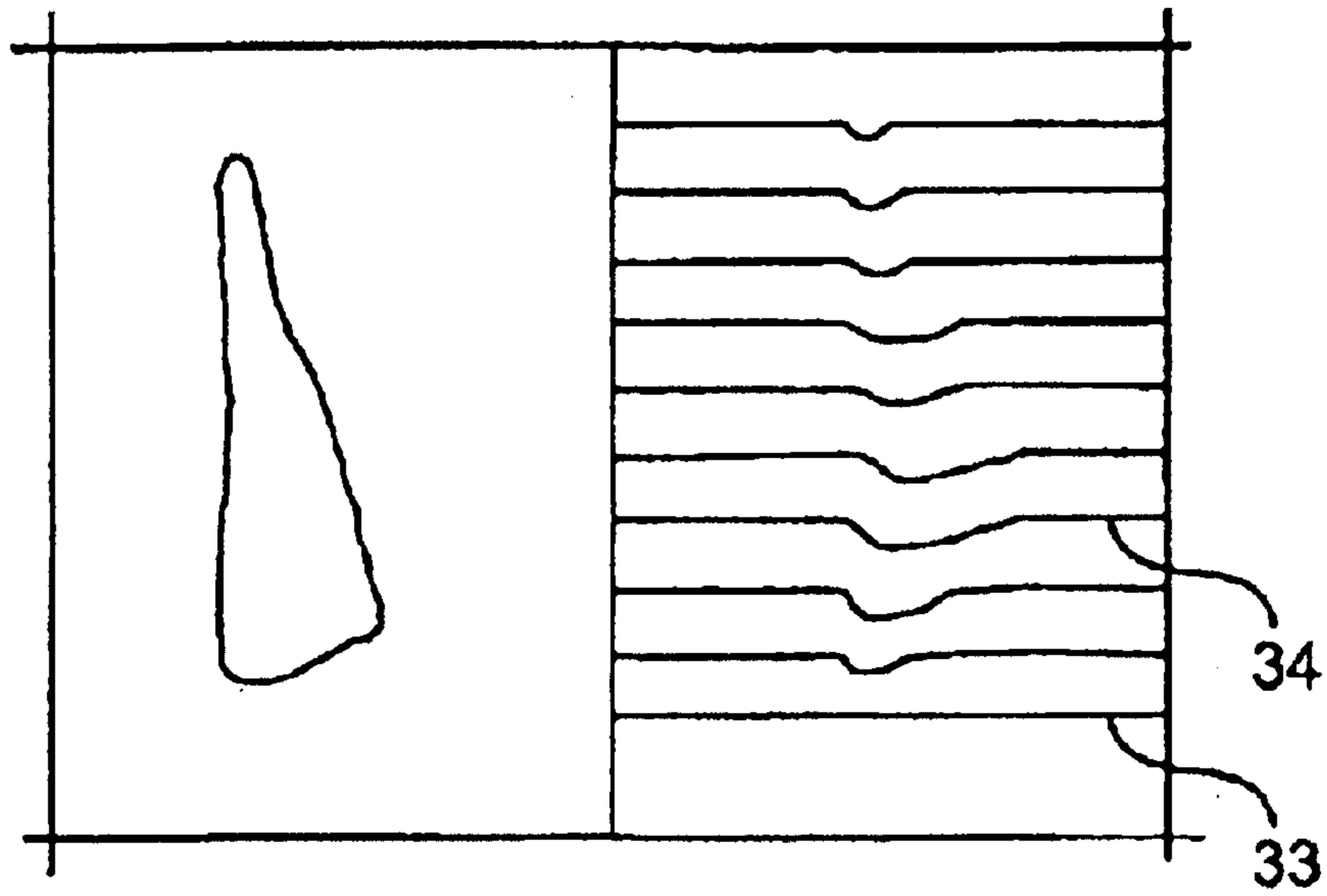
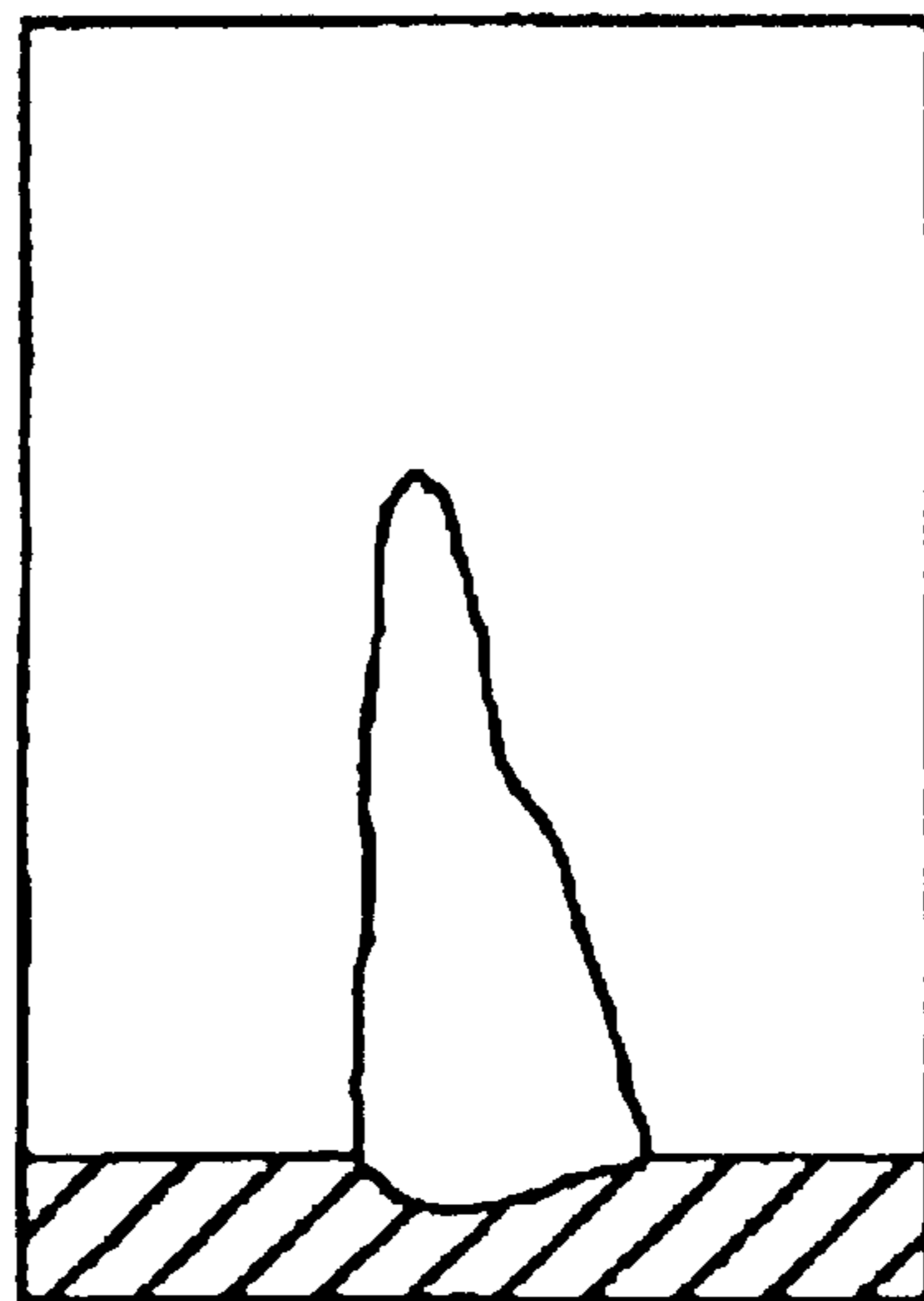

FIG. 1



**FIG. 2A FIG. 2B**



**FIG. 2C**

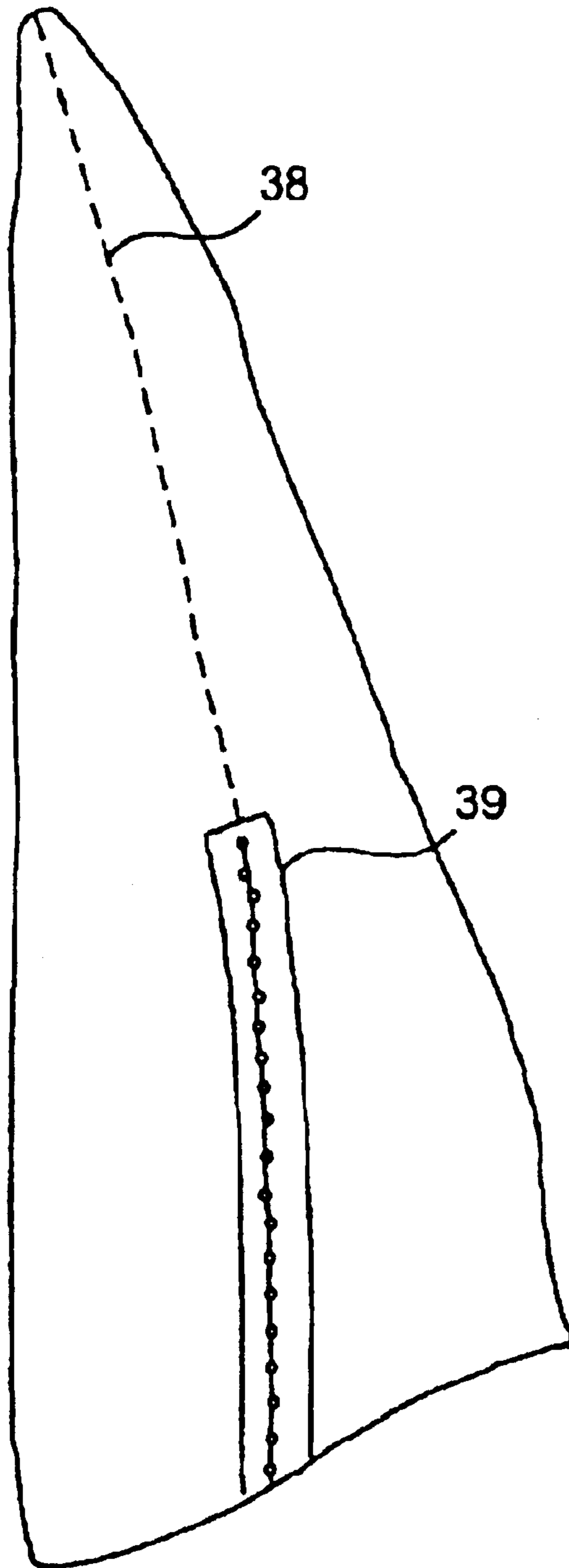

**FIG. 3**

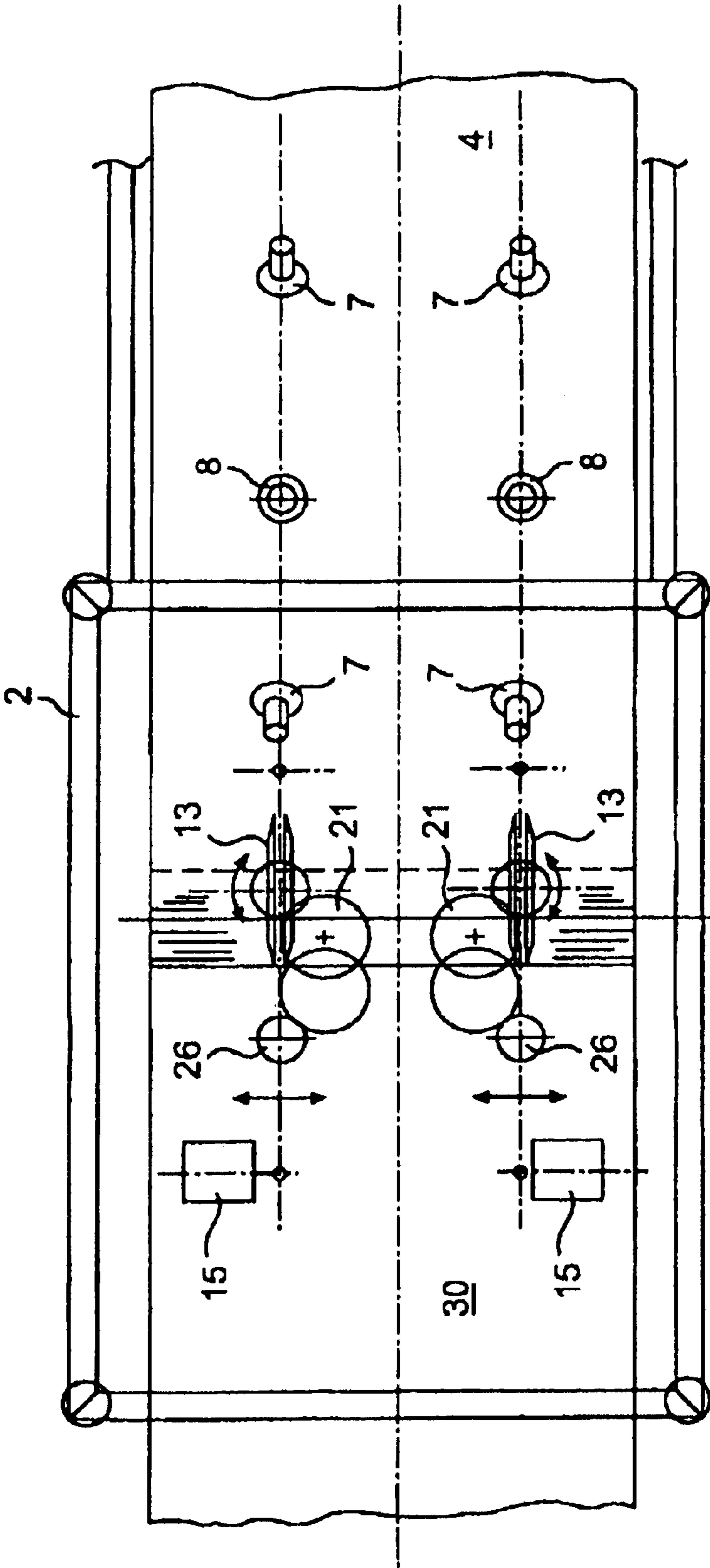

FIG. 4



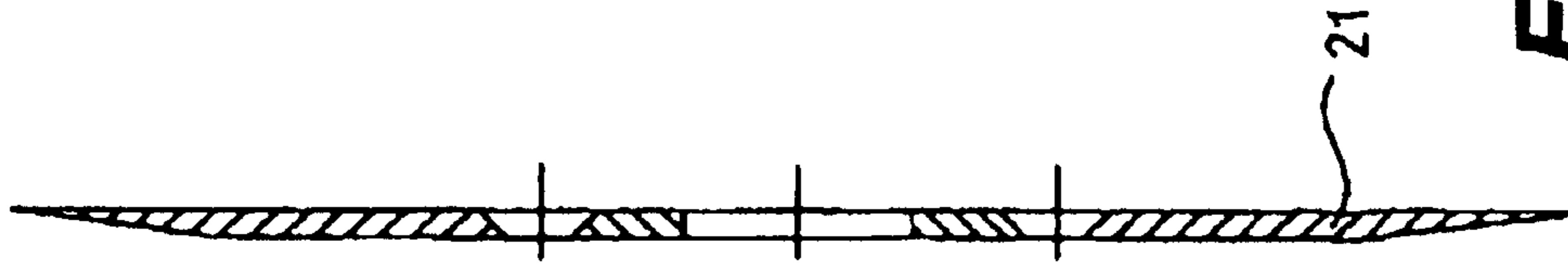
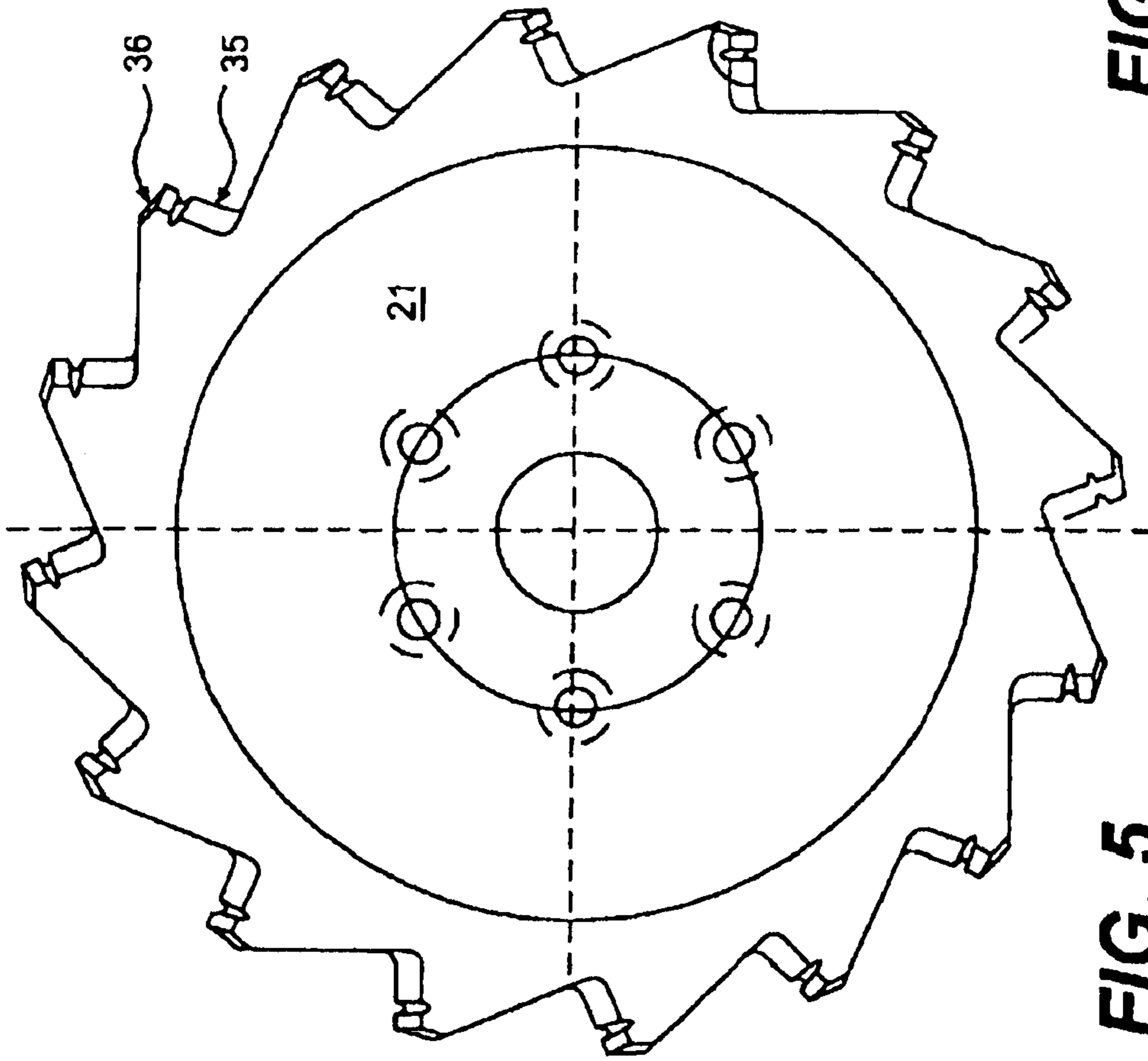

FIG. 6A

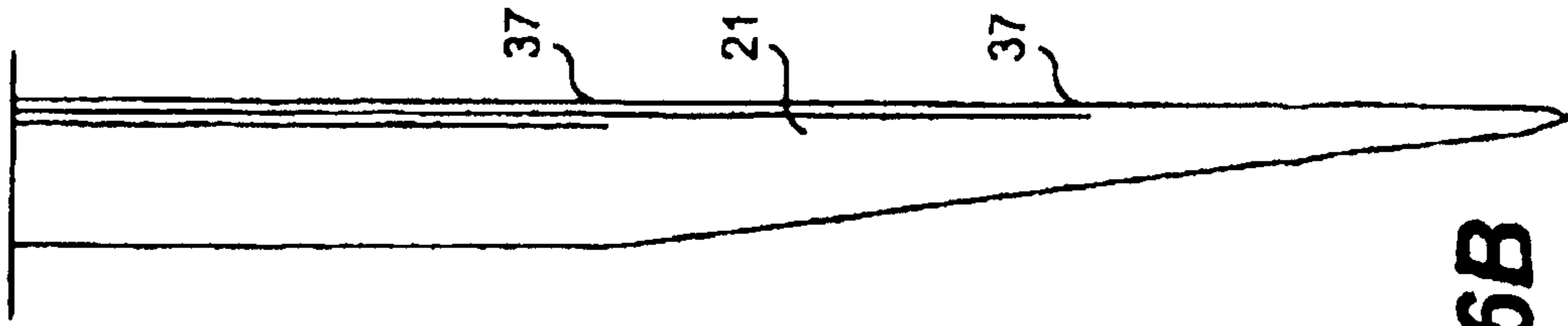
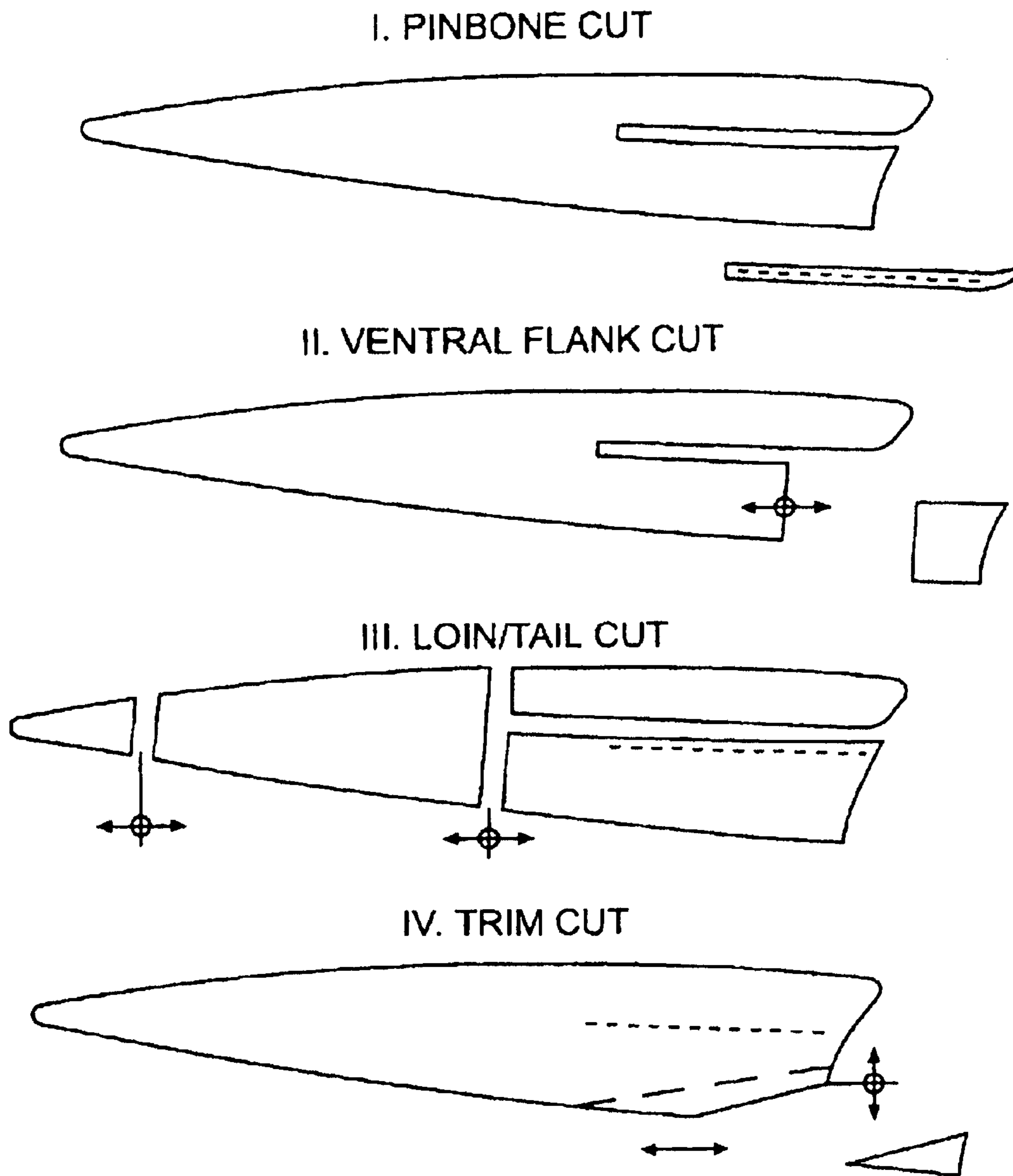
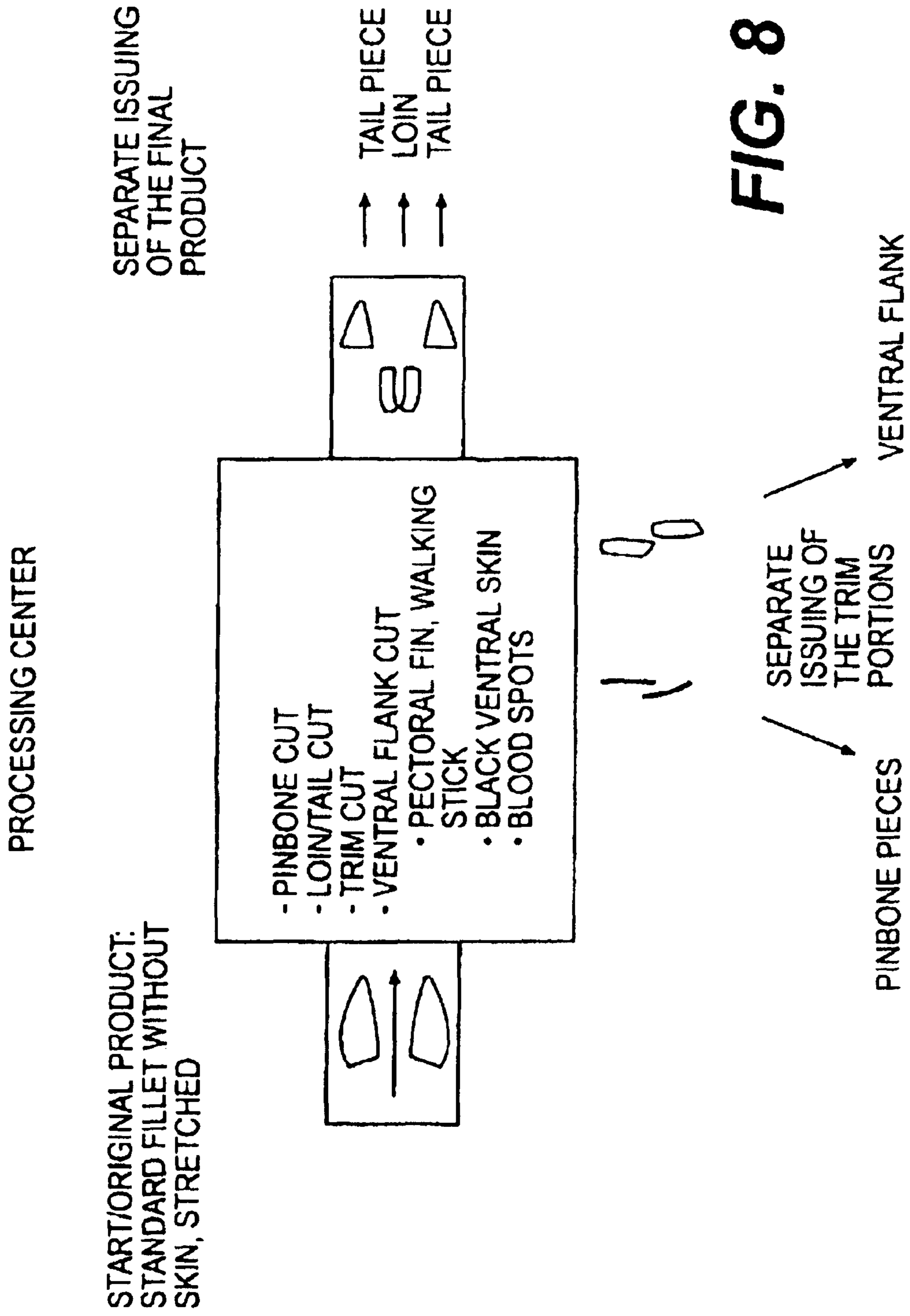

FIG. 6B



**FIG. 7**





1

**DEVICE AND METHOD RESPECTIVELY  
FOR PROCESSING FLESH**

**Matter enclosed in heavy brackets [ ] appears in the original patent but forms no part of this reissue specification; matter printed in italics indicates the additions made by reissue.**

This is a continuation application of U.S. Ser. No. 09/744,519, filed Apr. 19, 2001, now U.S. Pat. No. 6,604,991; *which is a 371 of PCT/EP99/05283 filed Jul. 27, 1999.*

The invention concerns a device or a method for processing flesh such as e.g. fish. Such a method or such a device is known, for example from U.S. Pat. No. 4,557,019. In this an automatic fish fillet cutting device together with associated method is disclosed, producing portions with a predetermined weight. Here it is a drawback that determination of the density of the fish fillet necessitates several manual working steps. Another drawback results from the fact that cutting of the fillet pieces is effected transversely to the direction of conveying.

It is the object of the present invention to provide a device or a method which enable automated reliable and flexible processing of fish.

The object is achieved according to the invention by the fact that a device for processing flesh is provided, including at least one transport means, at least one element for position detection as well as at least one separating means and at least one regulating and/or control device, wherein the separating means communicates by means of the regulating and/or control device with the element for position detection. A development according to the invention provides that the separating means is arranged essentially freely slidably in the space in order to perform precise cuts.

In another development according to the invention it is provided that the separating means comprises at least one circular blade.

Further it can be provided according to the invention that a device for processing flesh is provided, including at least one transport means, at least one element for position detection as well as at least one means for removing areas of different consistency and at least one regulating and/or control device, wherein the means for removing areas of different consistency communicates by means of the regulating and/or control device with the element for position detection.

A development according to the invention provides that the means for removing areas of different consistency comprises at least two precisely spaced-apart circular blades.

In another development according to the invention it is provided that the device includes an element for position detection, wherein this element for position detection comprises at least one transmitter and at least one receiver.

Further it can be provided according to the invention that the transmitter is a light source and the receiver is an optoelectronic system.

A development according to the invention provides that between transmitter and receiver is arranged at least one shading element.

In another development according to the invention it is provided that the separating means is arranged essentially parallel to the transport means.

Further it can be provided according to the invention that a method is provided in which a device according to one or more of the above claims is used.

A practical example of the invention is shown in the drawings below. They show:

FIG. 1 is a side view of the device showing schematically the element for position detection

2

FIGS. 2a-c displays of the recordings filed in the memory of the image computer

FIG. 3 a view of a fillet after computer determination of the pinbone region

FIG. 4 a top view of the device

FIG. 5 a top view of the horizontal blade

FIG. 6a a section through the horizontal blade according to FIG. 5

FIG. 6b an enlarged view of the section according to FIG. 6a

FIG. 7 cutting variants

FIG. 8 schematic view

The device for processing 1 includes, as shown in FIG. 1, a housing 2, a transport means 3, wherein the transport means 3 has a perforated conveyor belt 4. In the processing region of the device 1 is located a suction box 5 which draws in the fillets lying on the perforated conveyor belt 4 during mechanical processing through the holes in the conveyor belt 4. The suction box 5 is connected by means of a suction pipe 19 to the vacuum pump 6, the vacuum pump 6 ensuring the required partial pressure. The device has an element for position detection 11 (FIG. 2) which has two transmitters 7, which in this embodiment are designed as a light source.

Furthermore for the light sources 7 there is a corresponding receiver 8 which is here constructed as an electronic camera. To provide areas of different illumination, between light source 7 and projection surface is arranged a shading element 9 which produces on the conveyor belt 4 a shadow region and an illuminated region. The electronic camera 8 is connected by signal wires 18 to the image computer 10. In the processing region above the suction box 5 are located separating means 12 including two essentially parallel, spaced-apart circular blades 13 arranged essentially vertically or within an angular range from 45° to 90° to the conveyor belt 4 and arranged essentially in the direction of conveying as well as a horizontal blade 21 which is arranged essentially transversely to the direction of conveying of the conveyor belt 4. In an alternative embodiment the spaced-apart separating means 12 can also be arranged obliquely to each other. Following and essentially below the conveyor belt 4 is located a skinning device 14 known in the art, as shown for example in JP 1202134 or SE 170906. Further, such skinning devices are known as Baader 52, wherein in the embodiment shown here the subsequent skinning refers only to fillets without a pinbone strip and/or ventral flank.

By means of the stepping motor 15, the circular blades 13 and the horizontal blade 21 are controlled essentially in a plane parallel to the conveyor belt 4 as a function of the signals transmitted via control wire 18 to the stepping motor. The speed pick-up or clock signal generator 16 is coupled to the conveyor belt drive motor 23 and delivers the information on movement of the transport means 3 or its conveyor belt 4 via the signal wires 18 to the image computer 10 and to the regulating/control device 22. The blades 13, 21 described above are driven by means of flexible shafts which are coupled by a reduction gear for flexible shafts 25 to the blade drive motor 17, wherein the blade drive motor operates at constant speed. In an alternative embodiment the blade drive motor communicates via signal wires 18 with the regulation/control device. The control/signal wires 18 connect all functional elements of the device 1 to the regulating/control device 22, so that essentially the blades 13 and 21, taking into account the individual position of the fillets on the conveyor belt 4 after image evaluation followed by computer analysis of the pinbones and e.g. the ventral flank of the fish fillets, are controlled in such a way that the pinbone strip is separated out from the fillet without skin by the

65



essentially parallel, spaced-apart circular blades **13**, and the ventral flank is separated out by the horizontal blade **21**. The drive mechanism of the horizontal blade **20** ensures, together with the horizontal blade pivot device **28**, that the horizontal blade **21** swings in, the moment the perforated conveyor belt conveys the ventral flank of the fish fillet into the radius of action of the horizontal blade **21**. The blade pivot device **28** operates in this embodiment pneumatically, and receives the pivot signal from the control device **22** at the appropriate moment by means of the signal wires **18**, and moves the blade **21** into a plane parallel to the conveyor belt **4** or to the fish fillet in order to separate the ventral flank essentially from the skin of the fillet. Analogously, the pair of circular blades **13** are lowered into the fillet the moment the control device **22** signals impingement of the pinbone strip to the circular blade lifting/lowering device **24** by means of the signal wires **18**, in such a way that only the pinbone strip is separated from the skin of the fillet by means of a chisel which is arranged between the blades **13**, and for this eventuality the blade **21** remains in the waiting position (outside the cutting region). By means of the stepping motor **26**, which can be seen in FIG. **5**, the common blade support **27** on which both the circular blades **13** and the horizontal blade **21** are arranged is brought into the position determined by the control unit. The suction box **5**, which is supplied with partial pressure by means of suction pipe **19** and vacuum pump **6**, always needs essentially the optimum suction power when a fillet passes into its input region. For this reason, in the suction pipe **19** is arranged a control valve **29** which, at the moment signalled by the control unit **22** via the signal wires **18**, exposes the full cross-section of the suction pipe **19**. After the fillet has passed through the processing stations described, it is transported away out of the range of action of the device **1** by the skinner **14** with the transport means **30**, for further processing.

The transport system generates at precise intervals of for example 20 mm. by means of a clock signal generator **16**, a clock signal which passes via a control/signal wire **18** to the regulating/control device **22**, as shown e.g. in FIG. **1**.

The video images of the electronic camera **8** are detected by the image computer for example at 25 images per second. The images are first stored temporarily in a precise memory area of the image computer **10**.

When the clock signal comes from the clock signal generator **16** of the transport system, an evaluation is made of the last image recorded and stored. The transition line to a shaded region **31** which is formed by the shading element **9** in connection with the light source **7** is examined. Here it is relevant whether it is a question of a straight shadow line **33** or a deflected shadow line **34**, that is, a so-called contour line, as shown in FIG. **3b**. Due to projection of a straight edge, a projected shadow line occurs at a precise region on the conveyor belt **4**. Shading is effected by the plate **9** which is mounted in the lighting chamber in such a way that it does not lie in the field of recording or vision of the camera, wherein the field of vision of the camera is composed of the shaded region **31** and the illuminated image region **32**, which can be seen in FIG. **1**. The shaded region **31** produced by the shading element **9** lies in the field of vision of the camera. On account of the angle between the light source and the camera, the shadow line in the camera image varies with respect to location and form when an object lies on the conveyor belt. If therefore there is deformation, the presence of a fillet on the conveyor belt is deduced.

If there is no fillet present, the current image in the memory of the image computer **10** is erased. But if there is a fillet present, a copy of the shadow line is filed in another

memory area of the image computer, as shown in FIG. **2a**. Therefore a topology map of the fillet is built up each time at the predetermined transport intervals. As soon as a fillet has been completely transported out of the shadow region, if there is a straight shadow line again after the deformations of the shadow line, a complete copy of the current camera image is stored in another memory area of the image computer **10**, as can be seen in FIG. **2c**. Immediately afterwards, image analysis is commenced on the copied image.

Each individual contour line **34** is analysed with the aid of so-called curve discussion, which as a result allows a statement about the contour shape of the area under analysis. In the location which is directly in the region to be analysed and in which the height is equal to zero, lies the outer boundary of the fish fillet. If these zero points are now joined e.g. by mathematical methods such as spline interpolation or the like methods, the result is a computer-generated outer contour which in combination e.g. with the detected contour shape allows a statement about the volume of the product presented. By multiplication by the relative density of the product, therefore, a statement about the weight of each individual product is possible.

First the recorded topology map is brought into register with the copied image. In a first step the topology reproduces the outer boundary of the fillet—its contour.

Next the contour is related to that of a representative fillet (standard fillet) stored in the image computer. This standard fillet contains information on morphological peculiarities of a given species, e.g. where the so-called pinbones are located. This can be illustrated in such a way that the standard fillet is pulled like a rubber skin into the contour of the fillet to be examined. In the process the external shape of the standard fillet can be distorted, but the basic proportions are preserved. In particular the position to be expected of the pinbone strip is therefore already clearly confined.

In the confined region of the position to be expected of the pinbone strip, a further analysis of the topology map is made. For each individual shadow line **34** the point which on account of the contour shape is located on the desired pinbone line is computer analysed, and there is differential comparison of the actual contour line with a mathematical curve.

The pinbone points thus derived from the contour lines are combined by a polynomial approximation into a smoothed line. This line is widened by a given tolerance, so that there is now further confinement of the possible pinbone line position **34**, as can be seen from FIG. **3**.

Within the given tolerance range, an analysis of the copied image is then made. With a mathematical filter function, in the halftones of the image a kind of trench structure is sought (lighter picture points merge with darker ones and then again with lighter ones). Here, use is made of the fact that the fat and cartilage strip in which the pinbones are embedded can be seen in the halftone image as a darker line. The points within the tolerance range which exhibit this trench structure are utilised as pinbone points.

The number of points found is again smoothed by a polynomial approximation and the polynomial parameters are transmitted via a RS 232 data link from the image computer **10** to the regulating/control device **22** which controls the stepping motors for the pinbone cut or ventral flank cut.

An improvement in visibility of the fat line is made in an alternative embodiment by means of lighting properties and optical glass filters. As the fat lines **38** which can be seen in FIG. **3** are reddish or brownish, an increase in contrast can be obtained with blue light. The possible pinbone position **39** is also shown in FIG. **3**. The use of blue glass filters for the



## 5

unshaded image region 32 is provided in combination with red glass filters for the shaded region 31. In a further alternative embodiment it is provided, as shown in FIG. 4, that several paths, e.g. two of them, are arranged adjacent to each other in order thus to process simultaneously the two fish halves arising for each fish.

In an alternative embodiment there is provision for the use of a camera to determine the contour lines and the use of a further camera to determine the halftone images, the two cameras cooperating in the manner already described with the device or its image computer 10.

The horizontal blade 21 shown in FIG. 5 has at the circumference an essentially blunt edge 36 which is not designed as a cutting edge. The actual cutting edges 35 are concealed in the sawtooth-like structure of the blade.

An alternative embodiment of the horizontal blade 21 shown in FIGS. 6a, b has on its lower side or on the side facing towards the fish skin two undercuts 37 which seem suitable for receiving in compensated fashion any cut remains arising as well as fish fillet which is added, in order not to hinder the cut in itself.

In FIG. 7 are shown the different cutting variants which can be obtained with the device according to the invention. First there is the so-called pinbone cut, which is produced with circular blades 13 from FIG. 1 from the fillets presented, after the element for position detection 11 in cooperation with the image computer 10 and the regulating/control device 22 has determined the position of the pinbones and transmitted it to the circular blades 13 via stepping motors 15, 26 as a cutting signal.

In the so-called ventral flank cut, in addition the horizontal blade 21 cuts off a piece from the ventral flank. The following cutting variants such as loin/tail cut and trim cut are in each case variants of the types of cut described above.

In a further embodiment according to FIG. 8, skinning takes place already before actual processing.

In FIG. 1 the fillet is produced after processing with a skinner 14. In the variant shown in FIG. 8 the preliminary skinning takes place in the device which is also referred to as a BA 53. Of this arrangement it is promised that the cuts can be made even more precisely.

With the device according to the invention there is therefore the possibility of making both pinbone cuts and loin/tail cuts or trim cuts or ventral flank cuts. Further it is possible to detect pectoral fins, walking sticks, blank ventral skin and/or blood spots. The separated residual pieces such as pinbone pieces or ventral flank are conveyed separately out of the machine, so that in this way they are available for subsequent further processing.

	Reference numbers
1	device for processing fish
2	housing
3	transport means
4	perforated conveyor belt
5	suction box
6	vacuum pump
7	transmitter (light source)
8	receiver (electronic camera)
9	shading element
10	image computer
11	element for position detection
12	separating means
13	circular blade
14	skinner
15	stepping motor

## 6

-continued

	Reference numbers
5	16 speed pick-up/clock signal generator
	17 blade drive motor
	18 control/signal wires
	19 suction pipe
	20 drive mechanism of horizontal blade
	21 horizontal blade
10	22 regulating/control device
	23 conveyor belt drive motor
	24 circular blade lifting/lowering device
	25 reduction gear for flexible shaft
	26 stepping motor
	27 common blade support
15	28 blade pivot device
	29 control valve
	30 transport means
	31 shaded region
	32 illuminated image region
	33 straight shadow line
20	34 deflected shadow line
	35 cutting edge
	36 blunt edge
	37 undercut
	38 fat line
	39 possible pinbone position

What is claimed is:

1. [A device] *An apparatus* for processing flesh including at least one transport means adapted to move flesh, at least one element which detects the position of the flesh, at least one separating means for making [variant,] *variant* cuts of the flesh, and at least one control [device] *apparatus*, wherein the element for detecting the position of the flesh is electronically connected with the separating means via the control [device] *apparatus*, and said element [for detecting the position of the flesh] provides information to be recorded and processed at least into geometric data of the flesh and image data of the flesh, so that separating cuts based on the geometric and image data can be made with the separating means, *wherein said element consists of a transmitter and a receiver for recording the geometric and image data and wherein the receiver is a single camera and the transmitter and receiver are positioned above the transport means.*

2. The [device] *apparatus* according to claim 1, wherein the separating means is controllable for the removal of areas of different consistency.

3. The [device] *apparatus* according to claim 1, wherein the element for position detection includes at least [one transmitter, at least one receiver, at least] one shading element and at least one computer-assisted image processing system.

4. The [device] *apparatus* according to claim 3, wherein the shading element is arranged between the transmitter and a projection surface.

5. The [device] *apparatus* according to claim 1, wherein the separating means is arranged essentially freely slidably in [the] *a* space in order to make precise cuts.

6. The [device] *apparatus* according to claim 1, wherein the separating means comprises at least one circular blade.

7. The [device] *apparatus* according to claim 1, wherein the separating means comprises at least two essentially parallel, spaced-apart circular blades, wherein a cutting plane of the circular blade lies essentially perpendicularly to the conveying plane.

8. The [device] *apparatus* according to claim 7, wherein the separating means comprises at least one blade in addition to said two [blades] *blades*, whose cutting plane selectively lies essentially parallel or essentially perpendicularly to the conveying plane.

7

9. The [device] *apparatus* according to claim 8, wherein the transmitter is a light source and the receiver is an optoelectronic system.

[10. The device according to claim 3, wherein the receiver is a camera.]

11. A method for processing flesh, including the following steps:

transport of the flesh by a transport means into [the] *a* processing region of a device for processing flesh according to claim 1,

detection of the position and properties of the flesh by means of the element for position detection by recording information and processing the information at least into geometric data of the flesh and image data of the flesh, and

driving the separating means with the control [device] *apparatus* and performing separating cuts with the aid of the detected data according to a preselected processing [program.] *program*,

8

*characterized in that transmission and receiving of signals for detection of the position and properties of the flesh takes place from above the transport means and the geometric data and image data are recorded by means of a single camera which is a component of the element.*

[12. The method according to claim 11, wherein images are recorded by a camera.]

13. The method according to claim 11, wherein several complete images of the flesh to be processed are recorded, at a rate of 25 images per minute, and at least image details are stored and later processed for control of the separating means.

14. The [device] *apparatus* according to claim 1, wherein the separating means comprises at least two essentially parallel, spaced-apart circular blades arranged within an angular range from 45° to 90° to the conveyor belt.

\* \* \* \* \*

UNITED STATES PATENT AND TRADEMARK OFFICE  
**CERTIFICATE OF CORRECTION**

PATENT NO. : RE 41,409 E  
APPLICATION NO. : 11/351218  
DATED : June 29, 2010  
INVENTOR(S) : M. Jürs et al.

Page 1 of 1

It is certified that error appears in the above-identified patent and that said Letters Patent is hereby corrected as shown below:

**ON THE TITLE PAGE**

Please amend (73) Assignee as follows:

--(73) Assignee: **Nordischer Maschinenbau-~~Rud~~ Rud  
Baader GmbH + CO KG, Lubeck (DE)--**

Signed and Sealed this

Fifth Day of October, 2010



David J. Kappos  
*Director of the United States Patent and Trademark Office*