

US00RE41395E

(19) **United States**
(12) **Reissued Patent**
Jambhekar et al.

(10) **Patent Number:** **US RE41,395 E**
(45) **Date of Reissued Patent:** **Jun. 22, 2010**

(54) METHOD AND DEVICE FOR VEHICLE CONTROL EVENTS DATA RECORDING AND SECURING	3,938,092 A 2/1976 Callahan 4,884,202 A 11/1989 Ogawa et al. 4,890,226 A * 12/1989 Itoh 711/207 5,289,183 A 2/1994 Hassett et al. 5,311,197 A 5/1994 Sorden et al. 5,446,659 A 8/1995 Yamawaki 5,550,738 A 8/1996 Bailey et al. 5,784,704 A * 7/1998 Sanemitsu 711/164 5,805,082 A 9/1998 Hassett 5,815,093 A 9/1998 Kikinis 5,890,219 A * 3/1999 Scaringella et al. 711/162 6,028,537 A * 2/2000 Suman et al. 340/988
(75) Inventors: Shrirang Nilkanth Jambhekar , Palatine, IL (US); Jacques Hara , Glen Ellyn, IL (US); John Robert Barr , Barrington, IL (US)	
(73) Assignee: Temic Automotive of North America, Inc. , Deer Park, IL (US)	

FOREIGN PATENT DOCUMENTS

(21) Appl. No.: **10/166,818**
(22) Filed: **Jun. 11, 2002**

GB 2020127 A 11/1979

* cited by examiner

Related U.S. Patent Documents

Reissue of:

(64) Patent No.: **6,076,026**
Issued: **Jun. 13, 2000**
Appl. No.: **08/940,541**
Filed: **Sep. 30, 1997**

Primary Examiner—Gertrude Arthur Jeanglaud
(74) *Attorney, Agent, or Firm*—Brinks Hofer Gilson & Lione

(57) **ABSTRACT**

(51) **Int. Cl.**
G01M 17/00 (2006.01)

(52) **U.S. Cl.** **701/35**; 701/117; 340/901;
340/991; 340/426.1; 340/426.22; 340/426.28;
340/5.2; 340/5.72

(58) **Field of Classification Search** 711/152,
711/163, 164, 167; 713/182–184; 701/29,
701/32, 33, 35, 117; 340/426, 428, 459, 901,
340/991, 426.1

See application file for complete search history.

A device (100) and method (200, 300) authenticate and secure control event data for a vehicle, wherein the device includes: A) a microcontroller (104), coupled to receive control event information, for attaching a first time stamp and vehicle identification number VIN to the control event information to provide first information and sending the first information to memory (106) in time overlap fashion; B) the memory (106), coupled to the microcontroller (104) and a microprocessor (108), for storing first information and second information in time overlap fashion; and C) the microprocessor (108), coupled to the memory (106) and a plurality of transducers (110), for determining whether received impact data varies from previous impact data, and where received impact data varies, adding a second time stamp and VIN to the received impact data to form second information.

(56) **References Cited**
U.S. PATENT DOCUMENTS

3,704,344 A 11/1972 Newmeyer
3,864,731 A 2/1975 Callahan

61 Claims, 3 Drawing Sheets

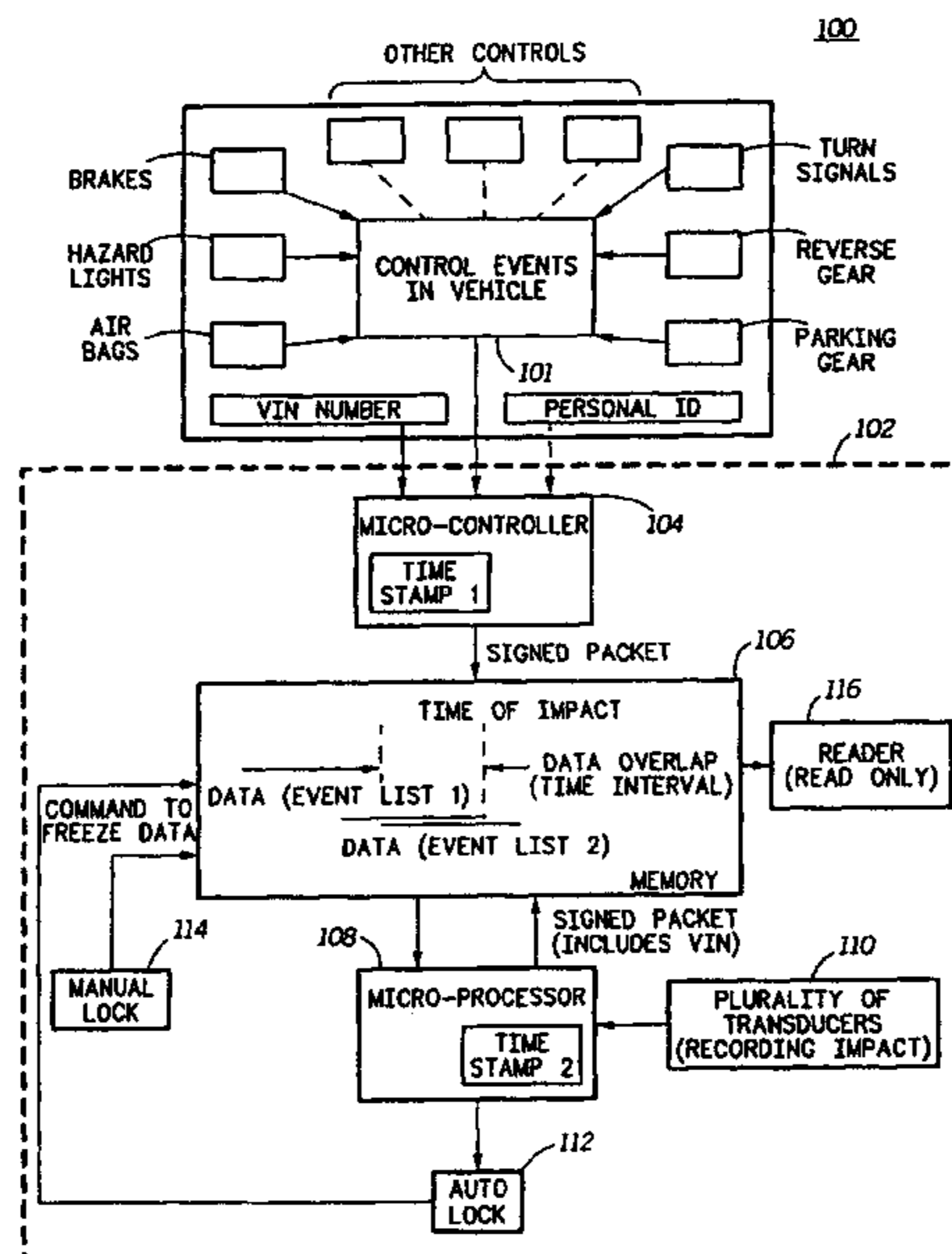

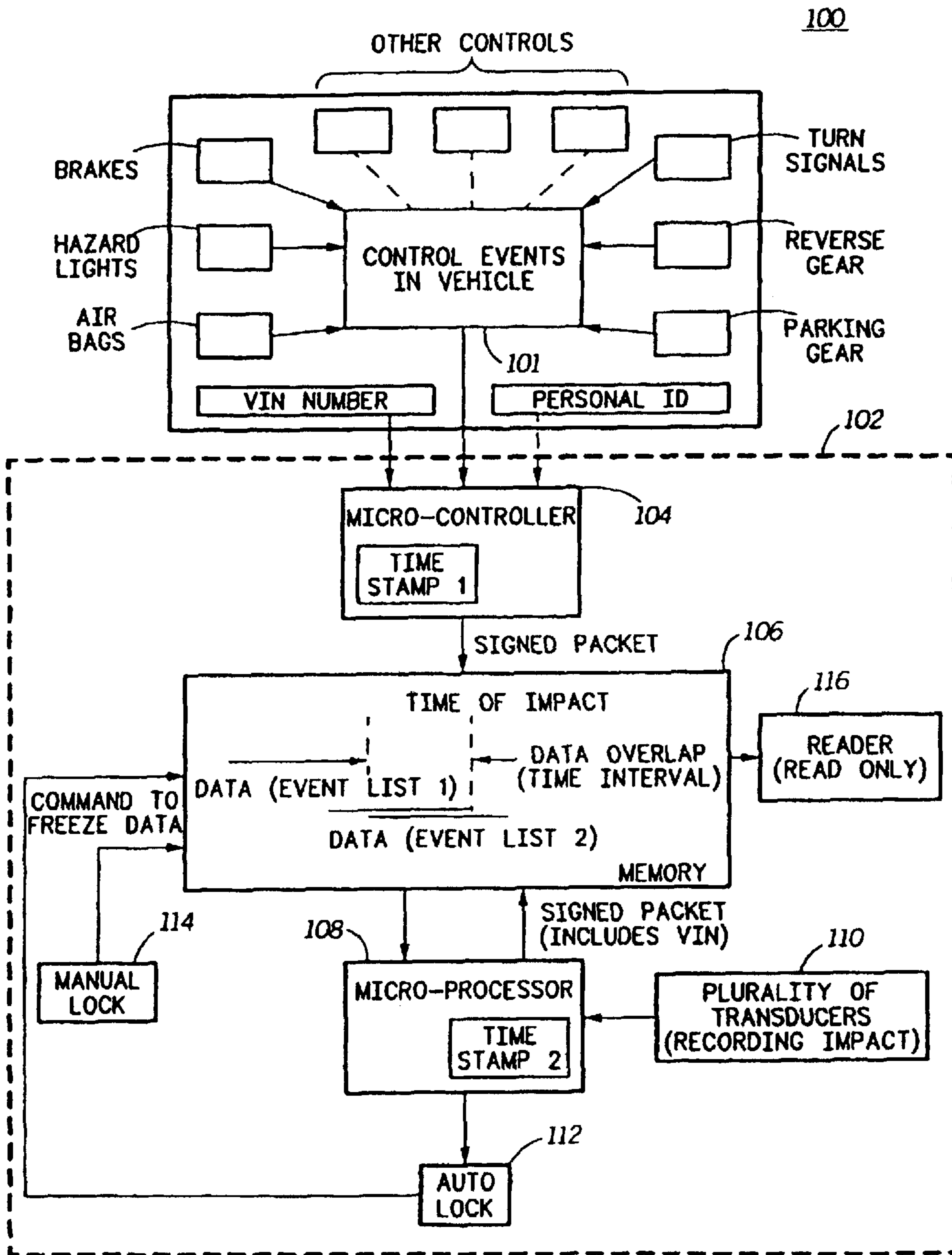

FIG. 1

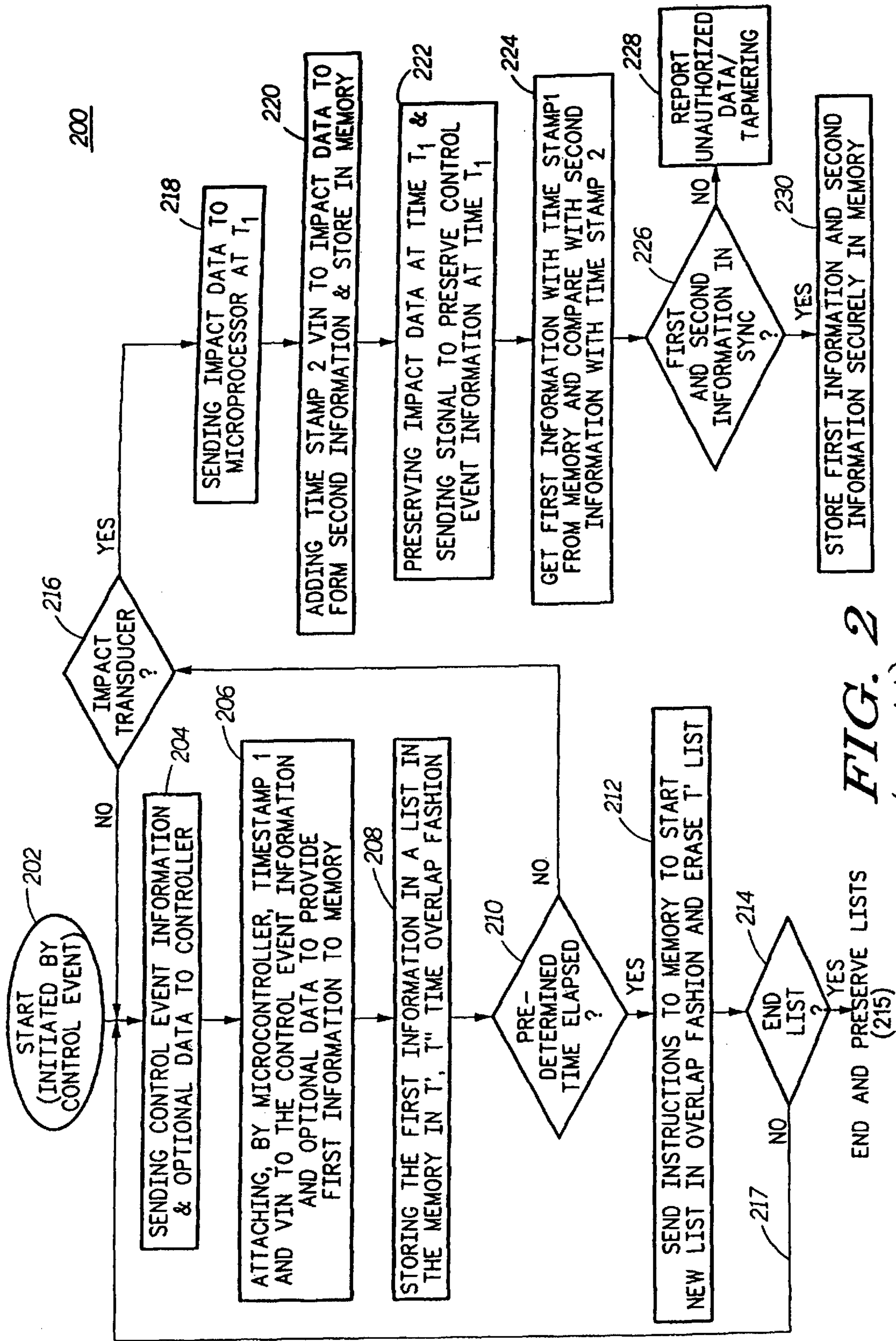
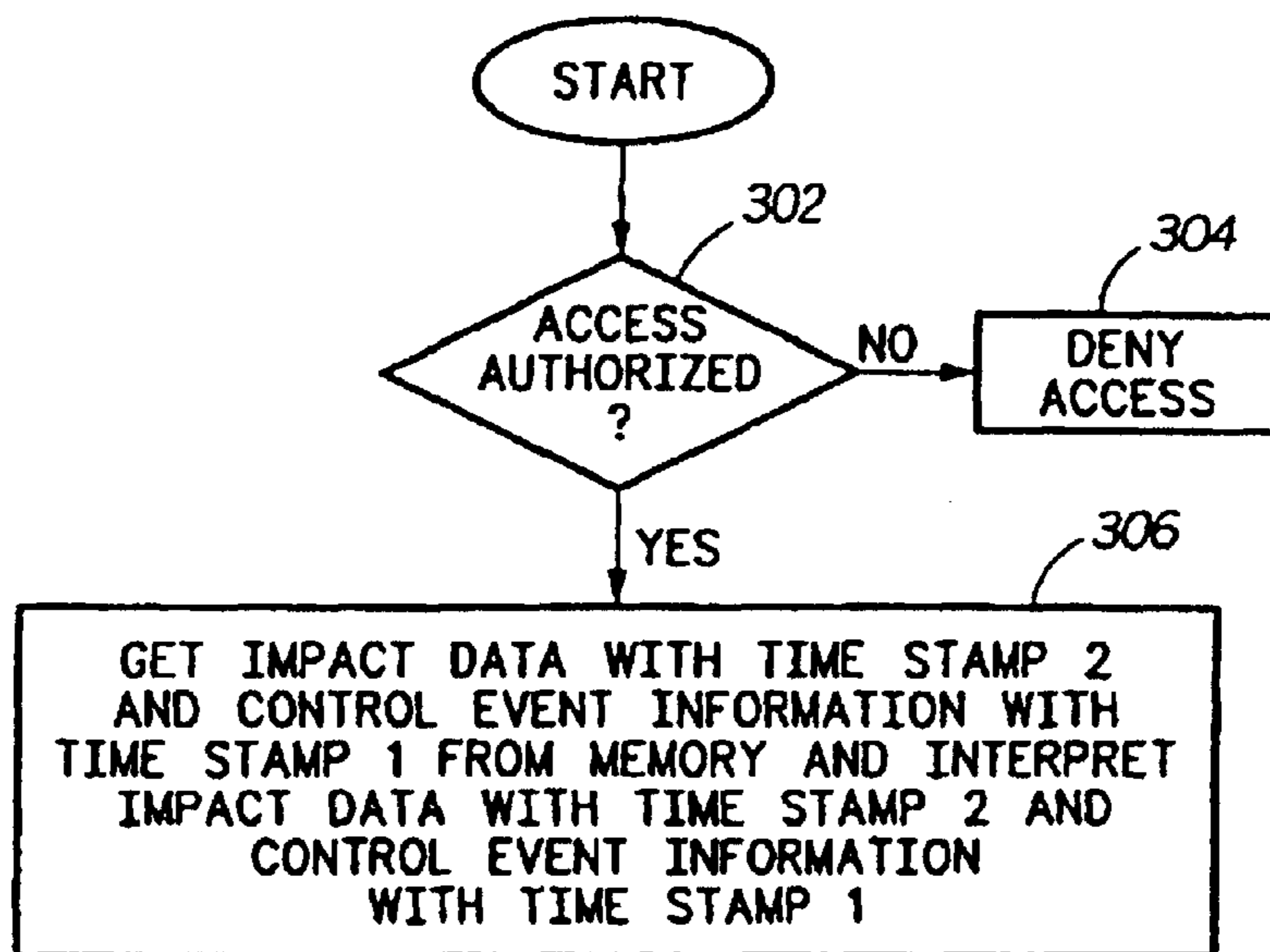
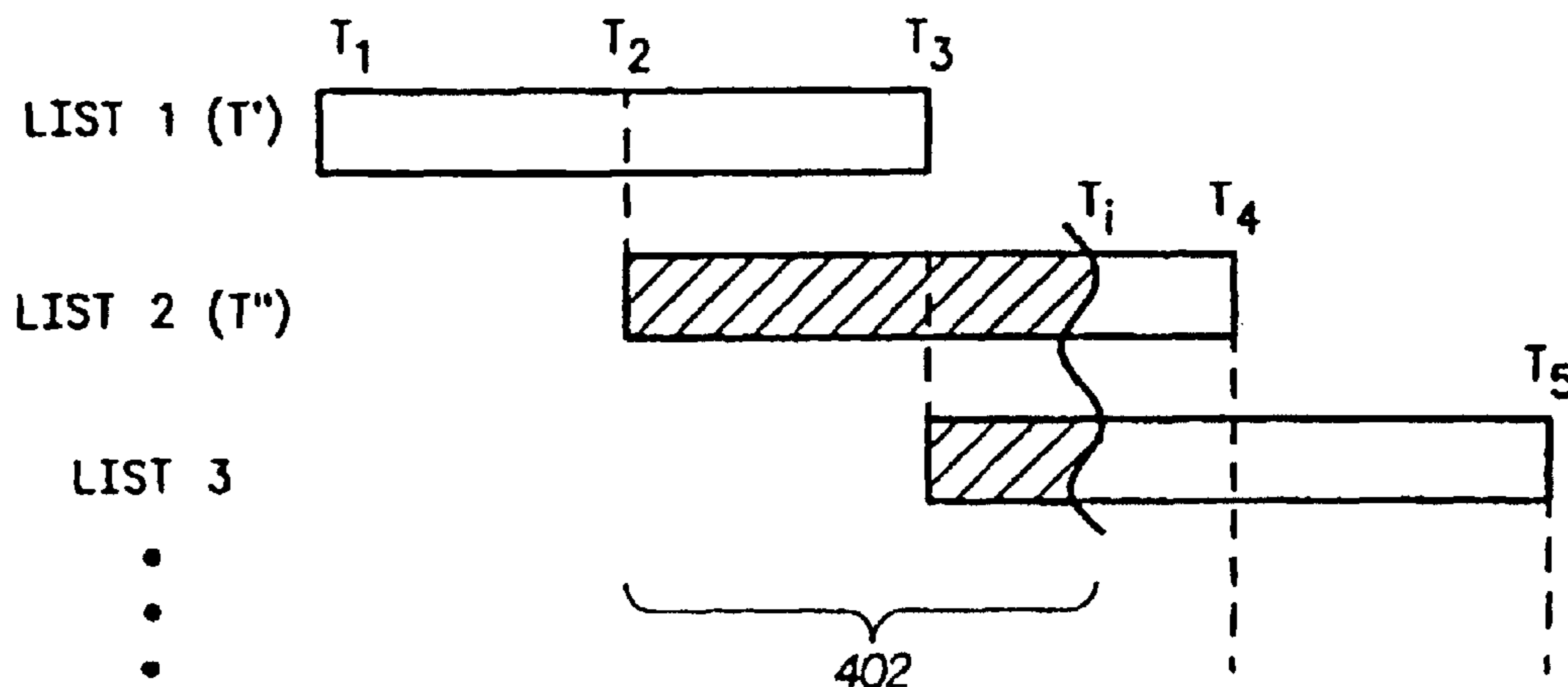

FIG. 2
(Amended)



300

FIG. 3



400

FIG. 4

1

METHOD AND DEVICE FOR VEHICLE CONTROL EVENTS DATA RECORDING AND SECURING

Matter enclosed in heavy brackets [] appears in the original patent but forms no part of this reissue specification; matter printed in italics indicates the additions made by reissue.

FIELD OF THE INVENTION

The present invention relates to vehicle control events, and more particularly to recording vehicle control events.

BACKGROUND OF THE INVENTION

For aircraft, vehicle control events are recorded and stored in a "black box" that is typically accessed when an accident occurs and is used to determine the cause of the accident. The "black box" is an airline cockpit voice data recorder that records verbal events. This type of recording device has been shown to be extremely useful in determining whether operator error or mechanical failure was the cause of the accident.

For automotive vehicles, however, no authenticated control event recorder has been developed for the purpose of analyzing and evaluating accident claims. When vehicles collide with one another, or are involved in accidents individually, there is no method currently available to determine the sequence of control events performed by the operator before, during and after the occurrence of the accident. Typically police require a report of the accident, but such a report generally relies upon the memories of the operators involved in the accident and any witnesses to the accident. In addition to an investigation by the police, insurance companies for the vehicle or vehicles involved may interview the operator or operators and witnesses to the accident. Often no factual identification of the operator at fault may be determined by the police or the insurance companies.

Thus there is a need for a method and device for authenticating and securing control event data for a vehicle.

BRIEF DESCRIPTION OF THE DRAWINGS

FIG. 1 is a block diagram of a device for authenticating and securing control event data in a vehicle in accordance with the present invention.

FIG. 2 is a flow chart of one embodiment of steps of a method for reliably storing control event data in a vehicle in accordance with the present invention.

FIG. 3 is a flow chart of one embodiment of steps of a method for authenticating impact data and control event information in a vehicle in accordance with the present invention.

FIG. 4 is a flow chart of one embodiment of steps of a method for interpreting control event data and impact data in a vehicle in accordance with the present invention.

DETAILED DESCRIPTION OF A PREFERRED EMBODIMENT

The present invention provides a device and method for authenticating and securing event data for a vehicle that may be utilized to analyze the cause of an accident by the police or an insurance agency to aid in their determination as to which driver was at fault, or alternatively, the failure of a vehicle electromechanical system. The method and device may also be utilized to determine whether a false insurance claim has been made. Authenticating event data, as used

2

herein, is defined as ensuring that genuine event data is being recorded by comparing the time stamps on microcontroller data and microprocessor data. Securing event data, as used herein, is defined as limiting access to the stored authenticated event data to certain predetermined agencies. Authenticating and securing the event data provides tamper-proof information about the chronological history of control events.

The present invention records all control events initiated by a driver and a plurality of data with respect to external agents. Data with respect to external agents may include, for example, the force of impact on an external surface of the vehicle body in a crash. Control event data is typically stored in a memory device by a microcontroller and a microprocessor (See FIGS. 2 and 3.). The microcontroller tracks predetermined inputs generated by control events such as turning on a hazard light or engaging a gear in reverse; the microprocessor maintains a record of the relationships between the driver's actions and those feedbacks generated by transducers measuring forces resulting from impacts (for example, impacts on bumpers, panels, doors, activation of airbags, etc. on impact in an accident). Data is stored on a first-in-first-out basis. If no impact occurs within a predetermined time period that is selected to maintain data storage within the limits of the memory, previous control information and data are simply overwritten. Alternatively, initialization of memory (i.e., deletion of stored data) may be initiated by an authorized user. An authorized user is typically a member of an insurance agency or the like. In case of impact, the memory record is secured in the memory device either automatically on registering the impact or, if the option is permitted, may be secured manually by the driver.

The events recorded by the microcontroller are "signed" by the microcontroller, i.e., include a time stamp and predetermined identification value/values to ensure that the recorded events were produced during the operation of the specific vehicle. Thus, data provides information for the microprocessor to compare with its own signed data to determine whether the microcontroller data is genuine. For example, one predetermined identification value is a vehicle identification number (VIN) of the vehicle being driven. The VIN is recorded along with the event information to identify the vehicle uniquely. Event information includes data with respect to impacting transducers and control event information and any other predetermined data collected. The vehicle may also support a recognition mechanism and a driver preference mechanism that allows determination of who was driving the vehicle during the signed period. The microprocessor has its own time stamp mechanism that is associated with the external impact sensors. The combination of the event recording and the impact sensing time stamps may be used to certify that the events were recorded at the time of the accident.

The secured record of events is then securely accessible to agencies like automobile insurance agencies or police agencies. The agencies may then analyze the data by securely accessing the memory device, retrieving and interpreting the secure records. Since only the insurance agencies and the police agencies will have access to the secure records, the accident claims may be monitored securely. The police agencies may use the secure event data to determine the cause of the accident and identify the party at fault.

Information stored on the memory device includes a dual record with a time phase difference to produce records overlapping by a predetermined amount. In this way when the first record is being erased, and an accident occurs at the same time, the initial portion of the out-of-phase record is

still available. A cumulative record is not generally possible since an unlimited amount of memory would be required, and a large portion of the record prior to an impact would typically not be helpful. In one embodiment, the event data is only accessed securely, using encryption and public key cryptography. The access mechanism may be implemented using a smart card. A smart card may be used as a mechanism to store the certified data that can be removed from the vehicle to be further processed remotely. The smart card acts as a standardized, modular, portable/removable device of convenience to the accessing authorized agencies. A smart card contains a certifiable key only known to the authorized agencies that can be authenticated by the microprocessor against public keys for those authorized agencies.

A secure mechanism may include deliberately setting the microprocessor time clock out of phase with the microcontroller time clock at a predetermined interval. That out of phase value is known only to the system setting of the microprocessor.

In one embodiment, the event record may be transmitted to a remote location (e.g., insurance agencies and police agencies) by use of a cellular phone or similar radio by sending out the event data utilizing a secure method. If a radio frequency device exists on the vehicle, the microprocessor can be programmed to call an authorized agency databank which will provide certifiable keys only known to the authorized agency that can be authenticated by the microprocessor against public keys for selected authorized agencies. Secure protocol can be used to prevent unauthorized reception of the event record.

The components of the present invention may be embodied as a contacted/contactless smartcard module that is readable through a smart card reader. Alternatively, the components may be embedded in the electronics of an automobile. For example, the components may be embodied as a unified device, a combination of a microcontroller and a microprocessor module in a single integrated circuit integrated with both input/output and memory components. *Accordingly, the microcontroller 104 and the micro-processor 108, either as separate components or unified in a single device, can be thought of as a processing system.* A third alternative uses a secure memory and a software program that enables use of existing microelectronics in the vehicle. The software functions in accordance with the method described below in FIG. 2.

FIG. 1, numeral 100, is a block diagram of a device for authenticating and securing control event data in a vehicle in accordance with the present invention. The device includes: A) a microcontroller, coupled to receive control event information, for attaching a first time stamp and vehicle identification number VIN to the control event information to provide first information and sending the first information to memory in time overlap fashion; B) the memory, coupled to the microcontroller and a microprocessor, for storing first information and second information in time overlap fashion; and C) the microprocessor, coupled to the memory and a plurality of transducers, for determining whether received impact data varies from previous impact data, and where received impact data varies, adding a second time stamp and VIN to the received impact data to form second information.

The device typically also includes an auto-lock unit coupled to the microprocessor for sending a signal to the memory to lock the first information and the second information in unchangeable form, or alternatively, a manual lock for sending a signal to the memory to lock the first information and the second information in unchangeable form.

FIG. 2, numeral 200, is a flow chart of one embodiment of steps of a method for reliably storing control event data in a vehicle in accordance with the present invention. The method includes the steps of: A) sending control event information and optional data to a microcontroller; B) attaching, by the microcontroller, a first time stamp and vehicle identification number VIN to the control event information and optional data to provide first information and sending the first information to a memory; C) storing the first information in a list in the memory in time overlap T', T'' fashion; D) determining whether a predetermined time has elapsed, and where the predetermined time is unelapsed, determining whether a transducer has encountered an impact; E) where the predetermined time has elapsed, sending instructions to the memory to start a new list in overlap fashion and erasing a T' list; F) determining whether to end the list; G) where the list is to be ended, ending and preserving the list; H) where the list fails to be ended, returning to step A; and I) where the transducer encounters an impact, sending impact data to a microprocessor at a time of impact, T_i ; J) adding time stamp 2 and VIN to impact data to form second information and storing the second information in memory; K) preserving the first information and the second information at time T_i the second information; L) comparing time stamp one of the first information with time stamp two of the second information; determining whether the first information is substantially synchronous with the second information within a predetermined range; M) where the first information is nonsynchronous with the second information, reporting unauthorized data tampering; and N) where the first information is synchronous with the second information, storing both the first information and the second information for authorized access at another time.

Control event information is generated as a result of actions by the driver. Control event information may include acceleration/deceleration information, braking information, hazard light initiation, air bag deployment, turn signal initiation, reverse gear implementation, parking gear initiation, hand brake initiation and the like. The VIN may be optional data sent to the microcontroller by the vehicle. Alternatively, the VIN number may already reside in the microcontroller. Other optional data may include, for example, a personal identification number that identifies the driver of the vehicle.

Storing first information in a list in memory in time overlap fashion means storing another list out of phase with the first list by a predetermined time.

Synchronicity of time stamp one and time stamp two may be determined by utilizing a preset value of time stamp in the microprocessor in a predetermined value so that the preselected synchronization difference is not known to an unauthorized person or device.

FIG. 3, numeral 300, is a flow chart of one embodiment of steps of a method for interpreting control event data and impact data in a vehicle in accordance with the present invention. The method includes the steps of: A) determining whether access is authorized to stored impact data with time stamp two and control event information and data with time stamp one in the vehicle; B) where access is unauthorized, denying access; C) where access is authorized, obtaining impact data with time stamp two and control event information and data with time stamp one and interpreting the impact data with time stamp two and control event information and data with time stamp one to provide an analysis of the accident.

FIG. 4, numeral 400, is a schematic representation of a time line for generation and maintenance of control event

5

information and optional data lists in the memory in accordance with the present invention. At time T_1 , showing the start of an initial control event, a list—list 1—is started. After a predetermined interval, i.e., at time T_2 , a second list is started. At time T_3 , a third list is started, at which time the list 1 is erased. This process is repeated until control event information and data generation is ended as shown in FIG. 2. The predetermined interval is $(T_1, T_2)=(T_2, T_3)=(T_3, T_4)=\dots$. When control event information and data generation is ended, the control event information and data is preserved. For example, as shown in FIG. 4, when a transducer encounters an impact, the time is T_i . The data (402) between time T_2 and T_i in list 2 and data between T_3 and T_i in list 3 is preserved and saved in memory. When the ignition is turned off, the data will be preserved and saved in a similar fashion.

The present invention may be embodied in other specific forms without departing from its spirit or essential characteristics. The described embodiments are to be considered in all respects only as illustrative and not restrictive. The scope of the invention is, therefore, indicated by the appended claims rather than by the foregoing description. All changes which come within the meaning and range of equivalency of the claims are to be embraced within their scope.

We claim:

1. A device for authenticating and securing control event data for a vehicle, comprising:

- A) a microcontroller, coupled to receive control event information, for attaching a first time stamp and vehicle identification number VIN to the control event information to provide first information and sending the first information to memory in time overlap fashion;
- B) the memory, coupled to the microcontroller and a microprocessor, for storing first information and second information in time overlap fashion; and
- C) the microprocessor, coupled to the memory and a plurality of transducers, for determining whether received impact data varies from previous impact data, and where received impact data varies, adding a second time stamp and VIN to the received impact data to form second information.

2. The device of claim 1 wherein the device further includes an auto-lock unit coupled to the microprocessor for sending a signal to the memory to lock the first information and the second information in unchangeable form.

3. The device of claim 1 wherein the device further includes a manual lock for sending a signal to the memory to lock the first information and the second information in unchangeable form.

4. A method for authenticating and securing control event data for a vehicle, comprising the steps of:

- A) sending control event information and data to a microcontroller;
- B) attaching, by the microcontroller, a first time stamp and vehicle identification number to the control event information and data to provide first information and sending the first information to a memory;
- C) storing the first information in a list in the memory in time overlap fashion;
- D) determining whether one of: an ignition of a vehicle is in off position and a predetermined time has elapsed, and where one of: the ignition is on and the predetermined time is unelapsed, determining whether any other control event has occurred;
- E) where another control event has occurred, returning to step A;
- F) where another control event has failed to occur, ending;

6

G) where one of: the ignition is in an off position and the predetermined time has elapsed, sending instructions to the memory to start a new list in overlap fashion;

H) determining whether another control event has occurred;

I) where another control event has occurred, returning to step A; and

J) where another control event has failed to occur, ending.

5. A method for authenticating impact data and control event information in a vehicle, comprising the steps of:

upon transducers being impacted,

A) sending impact data to a microprocessor;

B) determining whether impact data varies and where impact data fails to vary, ending, and where impact data varies, adding a time stamp two and a vehicle identification number to the impact data to form second information and storing the second information in memory;

C) determining whether a manual lock is in use and:

where the manual lock is in use, using the manual lock to retain the second information unchanged in memory;

and where a manual lock fails to be in use, using an auto lock to retain the second information unchanged in memory;

D) obtaining first information on control events and data and comparing with second information;

E) determining whether the first information and the second information is synchronized;

F) where the first information and the second information fails to be synchronized, reporting unauthenticated data/tampering; and

G) where the first information and second information is synchronized, storing the first information and the second information in memory.

6. A method for interpreting control event data and impact data in a vehicle to provide an analysis of an accident, comprising the steps of:

A) determining whether access is authorized to stored impact data with time stamp two and control event information and data with time stamp one in the vehicle;

B) where access is unauthorized, denying access;

C) where access is authorized, obtaining impact data with time stamp two and control event information and data with time stamp one and interpreting the impact data with time stamp two and control event information and data with time stamp one to provide an analysis of the accident.

7. A device for authenticating and securing control event information, comprising:

a processing system, coupled to receive control event information, for attaching a first time stamp to the control event information to provide first information and sending the first information to memory in time overlap fashion;

the memory, coupled to the processing system, for storing the first information and second information; and

the processing system, coupled to the memory and a transducer, for combining a second time stamp to impact data received from the transducer to form the second information.

8. The device of claim 7, wherein the processing system compares the first information with the second information.

9. The device of claim 7, wherein the processing system combines the second time stamp to the impact data in

7

response to determining that the impact data varies from previous impact data.

10. The device of claim 7, further comprising an auto-lock unit coupled to the processing system for sending a signal to the memory to lock the first information and the second information in unchangeable form.

11. The device of claim 7, further comprising a manual lock for sending a signal to the memory to lock the first information and the second information in unchangeable form.

12. The device of claim 7, wherein the control event information is associated with a vehicle.

13. The device of claim 7, wherein the processing system comprises:

a microcontroller, coupled to receive the control event information, for attaching the first time stamp to the control event information to provide the first information and sending the first information to the memory in time overlap fashion; and

a microprocessor, separate from the microcontroller and coupled to the memory and the transducer, for combining the second time stamp to the impact data received from the transducer to form the second information.

14. A device for authenticating and securing control event information, comprising:

a processing system, coupled to receive control event information, for providing first information to memory in time overlap fashion, wherein the first information comprises the control event information;

the memory, coupled to the processing system, for storing the first information and second information in time overlap fashion; and

the processing system, coupled to the memory and a transducer, for forming the second information, the second information comprising impact data received from the transducer.

15. The device of claim 14, wherein the processing system compares the first information with the second information.

16. The device of claim 14, wherein the processing system forms the second information in response to determining that the impact data varies from previous impact data.

17. The device of claim 14, wherein at least one of the first information and the second information stored in the memory comprises a dual record with a time phase difference to produce records overlapping by a predetermined amount.

18. The device of claim 17, wherein the dual record comprises a first list and a second list out of phase with the first list by a predetermined amount of time.

19. The device of claim 14, further comprising an auto-lock unit coupled to the processing system for sending a signal to the memory to lock the first information and the second information in unchangeable form.

20. The device of claim 14, further comprising a manual lock for sending a signal to the memory to lock the first information and the second information in unchangeable form.

21. The device of claim 14, wherein the control event information is associated with a vehicle.

22. The device of claim 14, wherein the processing system comprises:

a microcontroller, coupled to receive the control event information, for providing the first information to the memory in time overlap fashion, wherein the first information comprises the control event information; and

a microprocessor, separate from the microcontroller and coupled to the memory and the transducer, for forming

8

the second information, the second information comprising impact data received from the transducer.

23. The device of claim 25, wherein the control event information is associated with a vehicle.

24. The device of claim 23, wherein the identification number comprises an identification number of the vehicle.

25. A device for authenticating and securing control event information, comprising:

a processing system, coupled to receive control event information, for attaching an identification number to the control event information to provide first information and sending the first information to memory;

the memory, coupled to the processing system, for storing the first information and second information; and

the processing system, coupled to the memory and a transducer, for combining the identification number to impact data received from the transducer to form the second information, wherein the processing system compares the first information with the second information.

26. The device of claim 25, wherein the processing system combines the identification number to the impact data in response to determining that the impact data varies from previous impact data.

27. A device for authenticating and securing control event information, comprising:

a processing system, coupled to receive control event information, for attaching an identification number to the control event information to provide first information and sending the first information to memory;

the memory, coupled to the processing system, for storing the first information and second information;

the processing system, coupled to the memory and a transducer, for combining the identification number to impact data received from the transducer to form the second information; and

an auto-lock unit coupled to the processing system for sending a signal to the memory to lock the first information and the second information in unchangeable form.

28. A device for authenticating and securing control event information, comprising:

a processing system, coupled to receive control event information, for attaching an identification number to the control event information to provide first information and sending the first information to memory;

the memory, coupled to the processing system, for storing the first information and second information;

the processing system, coupled to the memory and a transducer, for combining the identification number to impact data received from the transducer to form the second information; and

a manual lock for sending a signal to the memory to lock the first information and the second information in unchangeable form.

29. The device of claim 25, wherein the processing system comprises:

a microcontroller, coupled to receive the control event information, for attaching the identification number to the control event information to provide the first information and sending the first information to the memory; and

a microprocessor, separate from the microcontroller and coupled to the memory and the transducer, for combining the identification number to the impact data received from the transducer to form the second information.

30. A method for authenticating and securing control event information, comprising:

attaching a first time stamp to control event information to provide first information; and

upon at least one transducer being impacted:

combining a second time stamp to impact data received from the at least one transducer to form second information; and

comparing the first information to the second information.

31. The method of claim 30, further comprising preserving the first information and the second information at a particular time of impact.

32. The method of claim 30, wherein the combining is executed in response to determining that the impact data varies with respect to previous impact data.

33. The method of claim 30, further comprising, upon the at least one transducer being impacted, reporting unauthorized data tampering if the first information is nonsynchronous with the second information.

34. The method of claim 30, further comprising, upon the at least one transducer being impacted, storing the first information and the second information if the first information is synchronous with the second information.

35. The method of claim 30, wherein at least one of the first information and the second information is stored in time overlap fashion.

36. The method of claim 30, wherein the control event information is associated with a vehicle.

37. The method of claim 36, wherein the attaching the first time stamp to the control event information comprises attaching an identification number of the vehicle to the control event information to provide the first information.

38. The method of claim 36, wherein the combining the second time stamp to the impact data comprises combining an identification number of the vehicle to the impact data to form the second information.

39. A device for authenticating and securing information, comprising:

a processing system to provide first information and sending the first information to memory in time overlap fashion with respect to second information; and

the memory, coupled to the processing system, for storing the first information and the second information, wherein the processing system is coupled to the memory and a transducer, for combining a time stamp to impact data received from the transducer to form the second information.

40. The device of claim 39, wherein the processing system combines the time stamp to the impact data in response to determining that the impact data varies from previous impact data.

41. The device of claim 39, further comprising an auto-lock unit coupled to the processing system and sends a signal to the memory to lock the first information and the second information in unchangeable form.

42. The device of claim 39, further comprising a manual lock for sending a signal to the memory to lock the first information and the second information in unchangeable form.

43. The device of claim 39, wherein the first information comprises control event information associated with a vehicle.

44. The device of claim 45, wherein the processing system is coupled to the memory and a transducer, for combining a time stamp to impact data received from the transducer to form second information.

45. A device for authenticating and securing information, comprising:

a processing system to provide information that is a combination of a time stamp and an identification number and sending the information to memory; and

the memory, coupled to the processing system, for storing the information, wherein the processing system is coupled to the memory and a transducer, for combining a time stamp to impact data received from the transducer to form second information and wherein the processing system compares the information with the second information.

46. The device of claim 44, wherein the processing system combines the time stamp to the impact data in response to determining that the impact data varies from previous impact data.

47. A device for authenticating and securing information, comprising:

a processing system to provide information that is a combination of a time stamp and an identification number and sending the information to memory;

the memory, coupled to the processing system, for storing the information; and

an auto-lock unit coupled to the processing system and sends a signal to the memory to lock the information in unchangeable form.

48. A device for authenticating and securing information, comprising:

a processing system to provide information that is a combination of a time stamp and an identification number and sending the information to memory;

the memory, coupled to the processing system, for storing the information; and

a manual lock for sending a signal to the memory to lock the information in unchangeable form.

49. The device of claim 45, wherein the information comprises control event information associated with a vehicle.

50. A device for authenticating and securing information, comprising:

a processing system to provide first information and sending the first information to memory;

the memory, coupled to the processing system, for storing the first information and second information; and

a lock unit coupled to the processing system for sending a signal to the memory to lock the first information and the second information in unchangeable form.

51. The device of claim 49, wherein the first information comprises control event information is associated with a vehicle.

52. A method for authenticating and securing control event information, comprising:

attaching a first time stamp and an identification number to control event information to provide information; and

storing the information, wherein said storing comprises storing the information in time overlap fashion with second information.

53. The method of claim 52, wherein the control event information is associated with a vehicle.

54. A method of transmitting information from a vehicle to a remote location, the method comprising:

contacting from a vehicle a remote location;

providing a certifiable key from the remote location to the vehicle; and

11

sending event data from the vehicle in a secure manner to the remote location provided the certifiable key is authenticated as being genuine.

55. *The method of claim 54, wherein said remote location is an insurance agency.*

56. *The method of claim 54, wherein said remote location is a police agency.*

57. *The device of claim 1, wherein the microcontroller continuously attaches further time stamps to further control event information received subsequent to the receipt of the control event information by the microcontroller and prior to receipt of the impact data by the microprocessor.*

58. *The device of claim 7, wherein the processing system continuously attaches further time stamps to further control event information received subsequent to the receipt of the control event information by the processing system and prior to receipt of the impact data by the processing system.*

59. *A method for authenticating and securing control event information, comprising:*

12

attaching a first time stamp to a first control event information to provide first information;

attaching a second time stamp to a second control event information to provide second information, wherein the second control event occurs subsequent to the first control event;

storing the first information;

storing the second information; and

attaching a third time stamp to impact data that is generated subsequent to the second control event.

60. *The method of claim 59 wherein the first information is stored in time overlap fashion.*

61. *The method of claim 56, wherein the second information is stored in time overlap fashion.*

* * * * *