

US00RE41346E

(19) **United States**  
(12) **Reissued Patent**  
**Taylor**

(10) **Patent Number:** **US RE41,346 E**  
(45) **Date of Reissued Patent:** **\*May 25, 2010**

(54) **FLEXIBLE MATERIAL**  
(75) Inventor: **David Stirling Taylor**, Accrington (GB)  
(73) Assignee: **Stirling Mouldings Limited** (GB)  
(\*) Notice: This patent is subject to a terminal disclaimer.  
(21) Appl. No.: **11/269,919**  
(22) PCT Filed: **Jul. 13, 2000**  
(86) PCT No.: **PCT/GB00/02687**  
§ 371 (c)(1),  
(2), (4) Date: **Apr. 23, 2002**  
(87) PCT Pub. No.: **WO01/03530**  
PCT Pub. Date: **Jan. 18, 2001**

(56) **References Cited**  
U.S. PATENT DOCUMENTS  
2,751,609 A 6/1956 Oesterling et al.  
2,785,739 A 3/1957 McGregor, Jr. et al.  
3,020,186 A 2/1962 Lawrence  
3,137,746 A 6/1964 Seymour et al.  
3,285,768 A 11/1966 Habib  
3,285,800 A 11/1966 Bartell et al.  
3,293,671 A 12/1966 Griffin  
3,305,423 A \* 2/1967 Le Masson ..... 2/458  
3,404,406 A \* 10/1968 Balliet ..... 2/2.16  
3,441,638 A 4/1969 Patchell et al.  
3,465,364 A \* 9/1969 Edelson ..... 2/22

(Continued)

**FOREIGN PATENT DOCUMENTS**

DE 3641609 C1 2/1988  
DE 9102039 U 5/1991  
DE 4341722 6/1994

(Continued)

**OTHER PUBLICATIONS**

Sarna Xiro GmbH, EC Safety Data Sheet, Jan. 16, 2001, 5 pages.

(Continued)

**Related U.S. Patent Documents**

Reissue of:  
(64) Patent No.: **6,743,325**  
Issued: **Jun. 1, 2004**  
Appl. No.: **10/030,782**  
Filed: **Apr. 23, 2002**

(30) **Foreign Application Priority Data**  
Jul. 13, 1999 (GB) ..... 9916291

(51) **Int. Cl.**  
**B32B 38/04** (2006.01)

(52) **U.S. Cl.** ..... **156/265**; 156/259; 156/271;  
156/299; 156/300; 156/301; 156/512; 156/560;  
156/308.2; 428/141; 428/304.4; 2/16; 2/22;  
2/456

(58) **Field of Classification Search** ..... 2/455,  
2/456, 2.15, 2.16, 16, 20, 22, 23, 24; 156/301,  
156/560, 308.2, 259, 271, 264, 265, 299,  
156/300, 251, 515, 256, 512, 561, 583.1;  
428/141, 304.4, 71, 76, 304

See application file for complete search history.

*Primary Examiner*—Mark A Osele  
(74) *Attorney, Agent, or Firm*—Fitch, Even, Tabin & Flannery

(57) **ABSTRACT**

A flexible material includes a plurality of separate resilient elements joined to a flexible, resiliently stretchable substrate. Such a material is suitable for providing protective war for human and animal bodies. Preferably, the elements includes a foam material such as a closed cell polyethylene foam and the substrate includes a knitted fabric. In an advantageous embodiment, a second flexible substrate is bonded over the elements to sandwich them between the two layers of substrate.

**25 Claims, 3 Drawing Sheets**

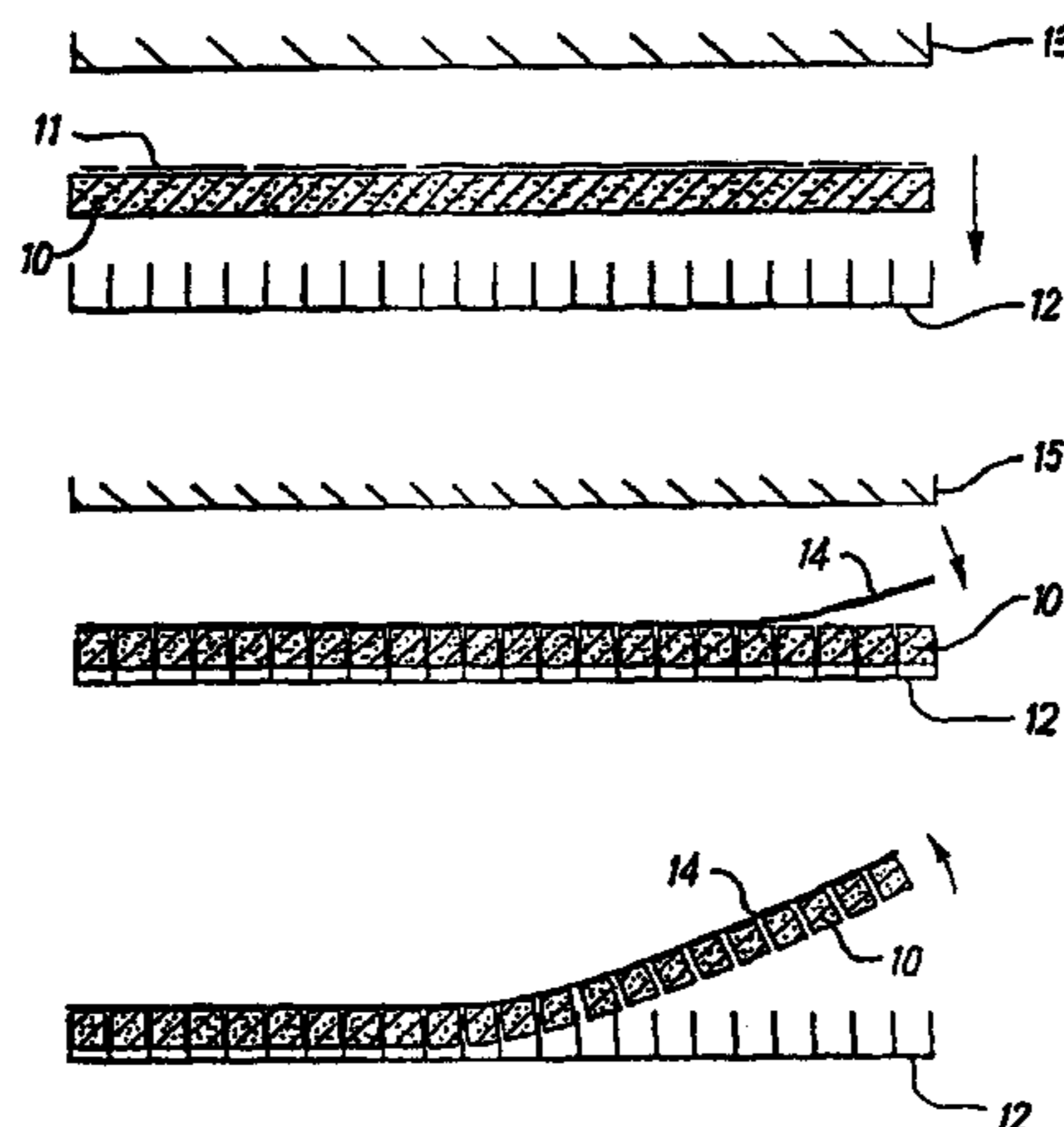

U.S. PATENT DOCUMENTS

3,471,865 A \* 10/1969 Molitoris ..... 2/423  
 3,512,190 A 5/1970 Buff  
 3,679,263 A 7/1972 Cadiou  
 3,746,605 A 7/1973 Dillon et al.  
 3,775,526 A 11/1973 Gilmore  
 3,867,238 A 2/1975 Johannsen  
 3,911,185 A 10/1975 Wright, Jr.  
 3,914,487 A \* 10/1975 Azoulay ..... 428/93  
 3,922,329 A 11/1975 Kim et al.  
 4,023,213 A \* 5/1977 Rovani ..... 2/413  
 4,126,177 A 11/1978 Smith et al.  
 4,136,222 A \* 1/1979 Jonnes ..... 428/116  
 4,138,283 A 2/1979 Hanusa  
 4,197,342 A 4/1980 Bethe  
 4,272,850 A 6/1981 Rule  
 4,276,341 A \* 6/1981 Tanaka ..... 442/183  
 4,415,622 A 11/1983 Kamat  
 4,482,592 A 11/1984 Kramer  
 4,485,919 A 12/1984 Sandel  
 4,507,801 A \* 4/1985 Kavanagh et al. .... 2/462  
 4,534,354 A 8/1985 Bonner, Jr. et al.  
 4,538,301 A 9/1985 Sawatzki et al.  
 4,581,186 A 4/1986 Larson  
 4,631,221 A 12/1986 Disselbeck et al.  
 4,646,367 A \* 3/1987 El Hassen ..... 2/411  
 4,692,199 A 9/1987 Kozlowski et al.  
 4,713,854 A \* 12/1987 Graebe ..... 5/652  
 4,718,214 A 1/1988 Waggoner  
 4,730,761 A 3/1988 Spano  
 4,734,306 A 3/1988 Lassiter  
 4,756,026 A \* 7/1988 Pierce, Jr. .... 2/16  
 4,809,374 A 3/1989 Saviez  
 4,856,393 A 8/1989 Braddon  
 4,859,274 A 8/1989 Marvel  
 4,867,826 A 9/1989 Wayte  
 5,052,053 A 10/1991 Peart et al.  
 5,129,295 A 7/1992 Geffros et al.  
 5,160,785 A 11/1992 Davidson, Jr.  
 5,168,576 A \* 12/1992 Krent et al. .... 2/456  
 5,188,879 A 2/1993 Hill et al.  
 5,232,762 A 8/1993 Ruby  
 5,353,455 A 10/1994 Loving et al.  
 5,360,653 A \* 11/1994 Ackley ..... 428/71  
 5,405,665 A 4/1995 Shukushima et al.  
 5,452,477 A \* 9/1995 Mann ..... 2/67  
 5,534,208 A 7/1996 Barr et al.  
 5,551,082 A \* 9/1996 Stewart et al. .... 2/465  
 5,594,954 A 1/1997 Huang  
 5,689,836 A 11/1997 Fee et al.  
 5,727,252 A 3/1998 Oetting et al.  
 5,780,147 A 7/1998 Sugahara et al.  
 5,823,981 A 10/1998 Grim et al.  
 6,070,267 A 6/2000 McKewin

6,070,273 A \* 6/2000 Sgro ..... 2/455  
 6,085,353 A 7/2000 van der Sleesen  
 6,093,468 A 7/2000 Toms et al.  
 6,167,790 B1 1/2001 Bambara et al.  
 6,235,661 B1 5/2001 Khanamirian  
 6,253,376 B1 7/2001 Ritter  
 6,295,654 B1 \* 10/2001 Farrell ..... 2/456  
 6,301,722 B1 10/2001 Nickerson et al.  
 6,317,888 B1 11/2001 McFarlane  
 6,374,409 B1 4/2002 Galy  
 6,485,448 B2 11/2002 Lamping et al.  
 6,584,616 B2 7/2003 Godshaw et al.  
 6,654,962 B2 12/2003 DeMott  
 6,820,279 B2 11/2004 Lesosky  
 6,841,022 B2 1/2005 Tsukagoshi et al.  
 6,851,124 B2 2/2005 Munoz et al.  
 6,968,573 B2 11/2005 Silver  
 7,007,356 B2 \* 3/2006 Cudney et al. .... 29/91.1

FOREIGN PATENT DOCUMENTS

DE 19640263 A1 4/1998  
 DE 202006013732 U 2/2007  
 EP 1 369 149 A1 12/2003  
 FR 2581348 A1 11/1986  
 FR 2635650 A1 3/1990  
 GB 800474 A 8/1958  
 GB 832101 A 4/1960  
 GB 2 304 539 A 3/1997  
 JP 1-316235 A 12/1989  
 JP 2508289 Y2 8/1996  
 JP 9300510 A 11/1997  
 JP 10043007 A 2/1998  
 JP 10337797 A 12/1998  
 WO WO 97/33493 9/1997  
 WO 1997036740 A1 10/1997  
 WO 2001/015892 A1 3/2001  
 WO 02/16124 A1 2/2002  
 WO 02/81202 A1 10/2002  
 WO 2006088734 A2 8/2006

OTHER PUBLICATIONS

Jeff Hopkins, "Advances, Advantages, and Techniques of Hot Melt Adhesives", Journal of Industrial Textiles, (1993), pp. 5-13.  
 John Halbmaier, "Overview of Hot Melt Adhesives Application Equipment For Coating Laminating Full-Width Fabrics", Journal Of Industrial Textiles, (1992), pp. 301-310.  
 Walter Fung, "Coated And Laminated Textiles", (2002), pp. 114-133.  
 SAE Specification AMS 3698A, (Jul. 1, 1987), 13 pages.  
 SAE Specificagion AMS 3698B, (Jan. 1, 1993), 1 page.

\* cited by examiner

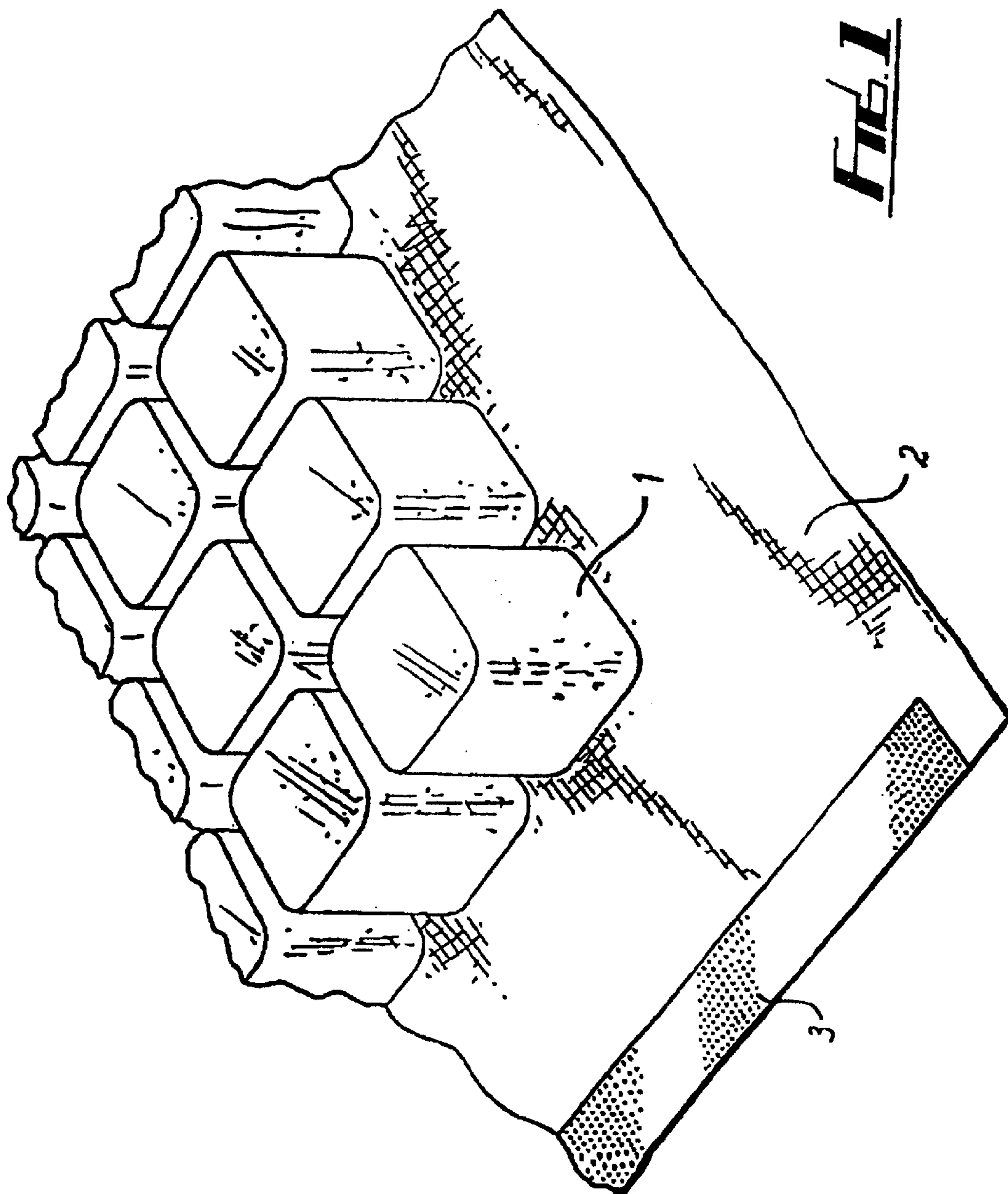

**FIG. 1**

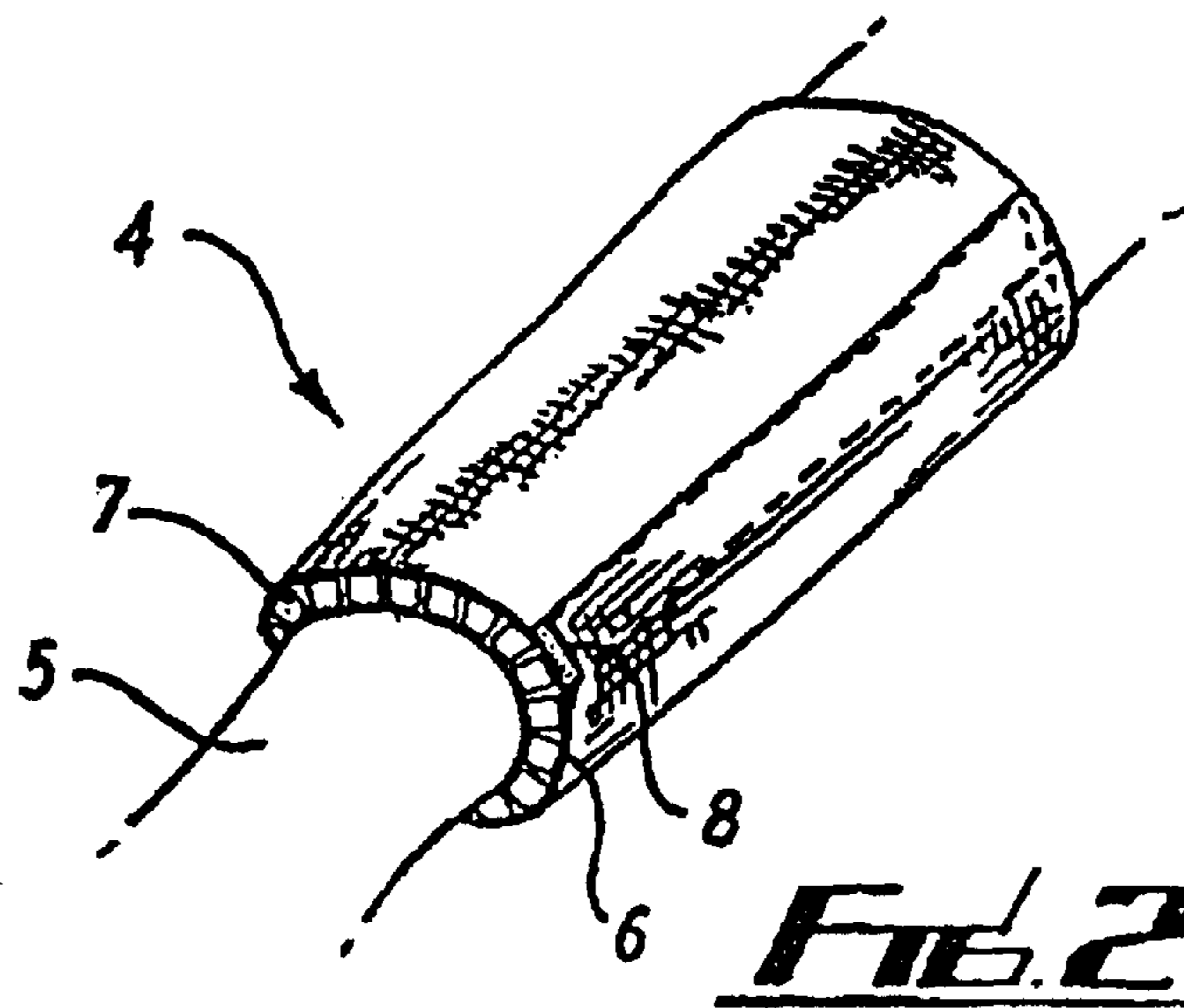

**FIG. 2**

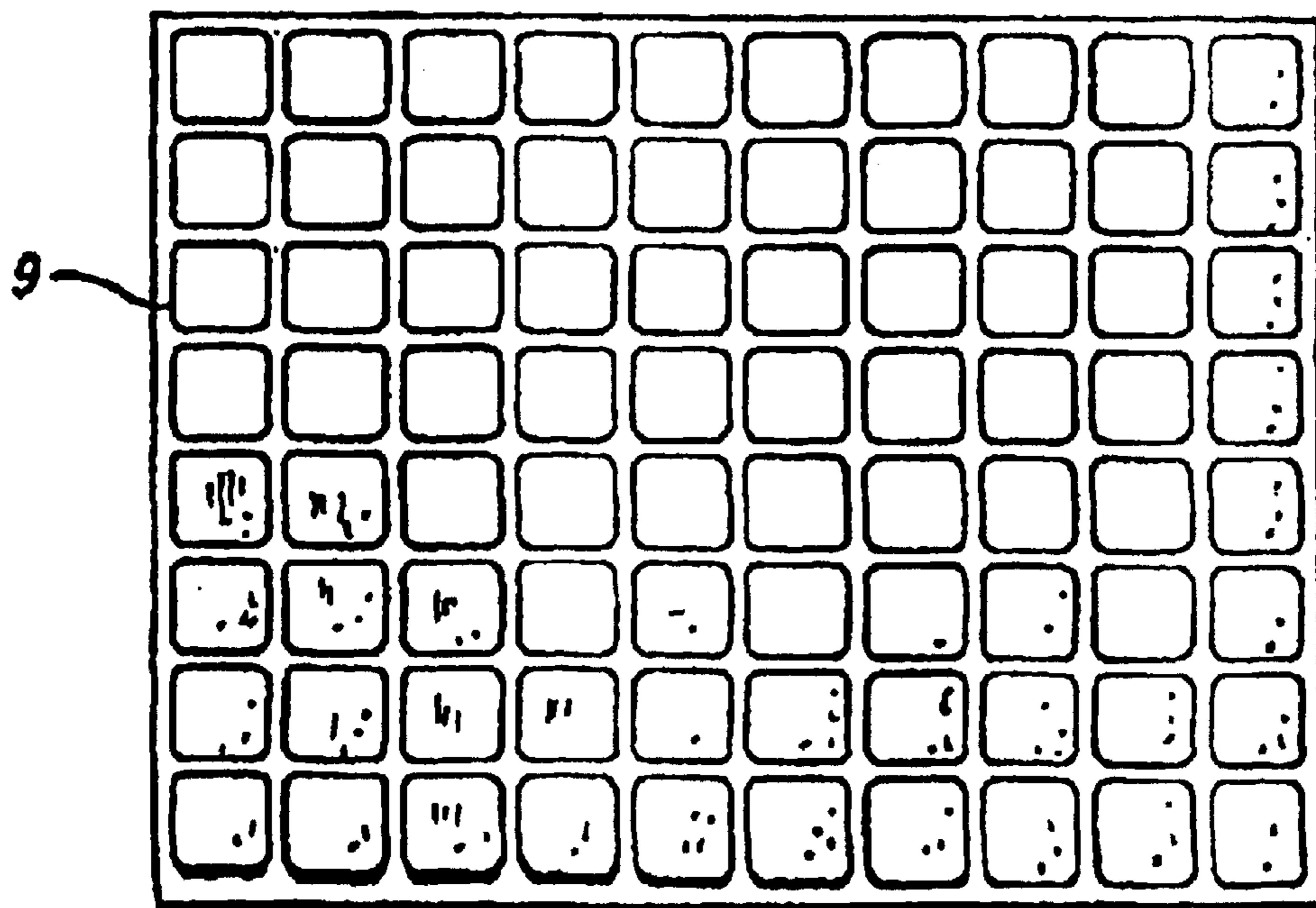

**FIG. 3**

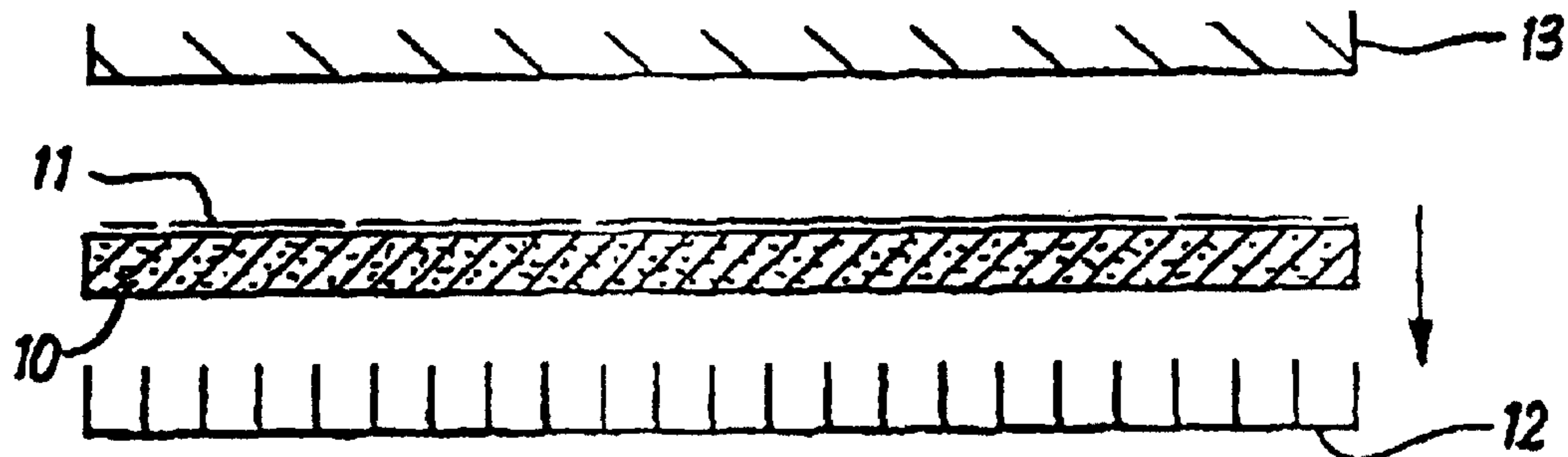

FIG. 4

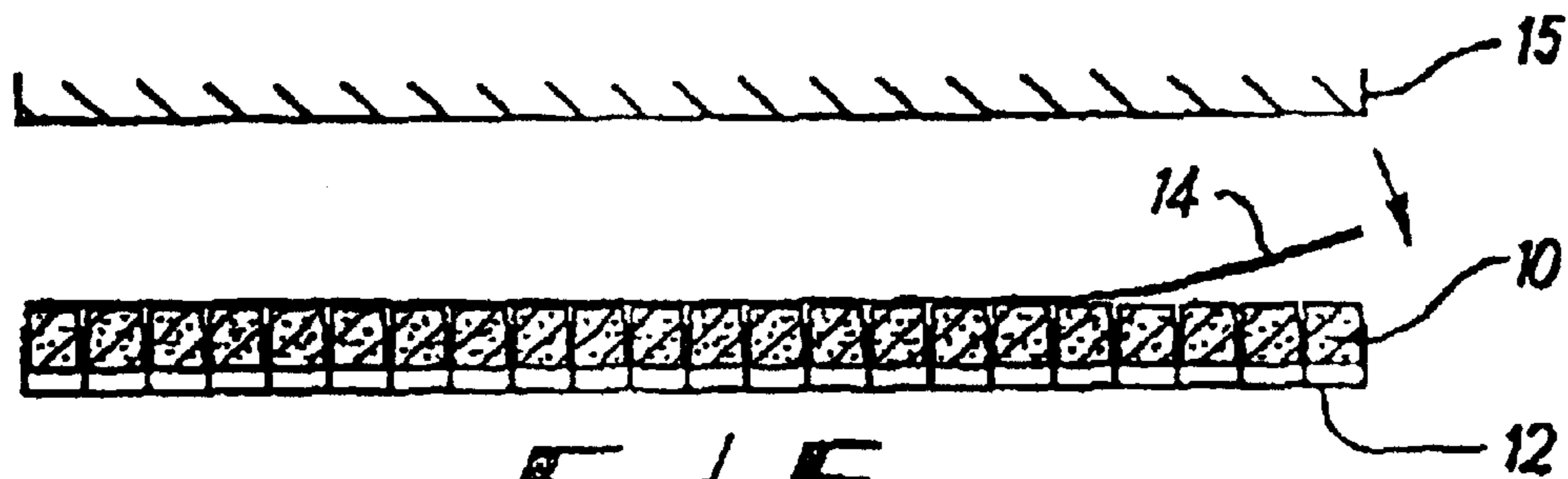

FIG. 5

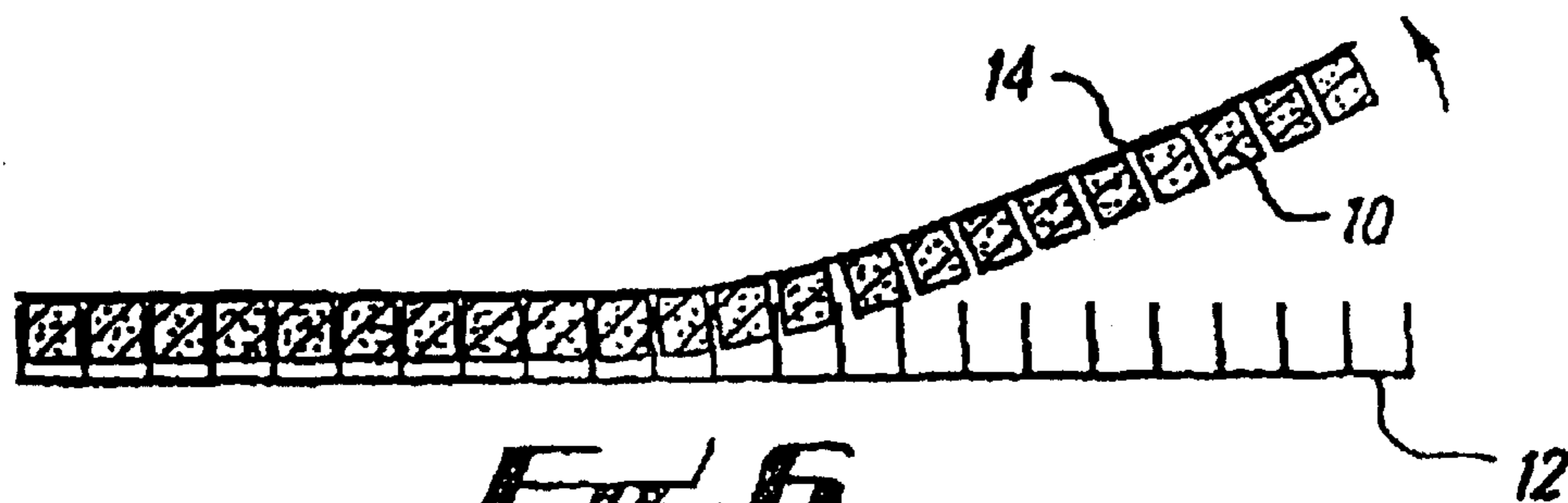

FIG. 6

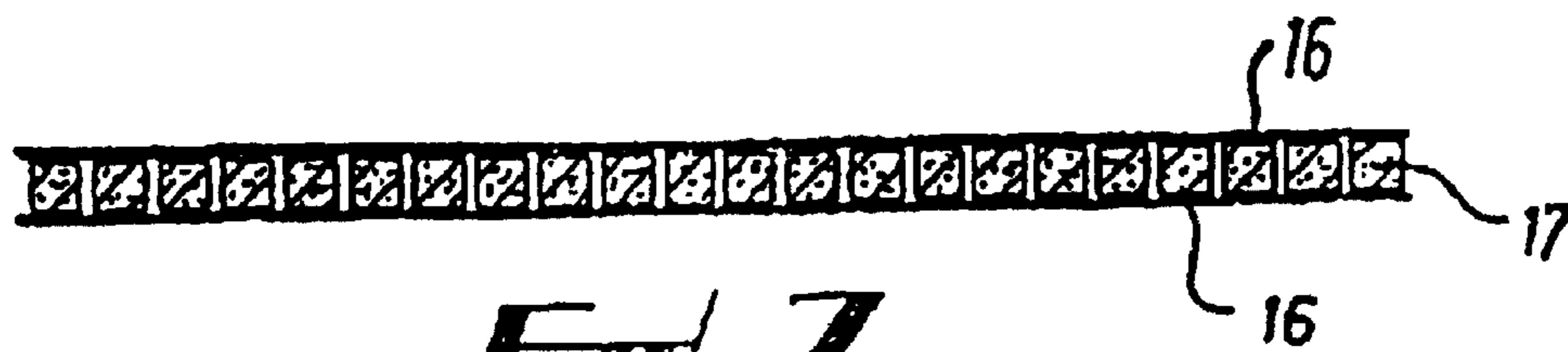

FIG. 7

## FLEXIBLE MATERIAL

**Matter enclosed in heavy brackets [ ] appears in the original patent but forms no part of this reissue specification; matter printed in italics indicates the additions made by reissue.**

## RELATED U.S. APPLICATIONS

Not applicable.

## STATEMENT REGARDING FEDERALLY SPONSORED RESEARCH OR DEVELOPMENT

Not applicable.

## REFERENCE TO MICROFICHE APPENDIX

Not applicable.

## FIELD OF THE INVENTION

The present invention relates to a method of manufacturing a flexible material suitable, primarily, for use as a flexible protective material to protect for human and animal bodies.

## BACKGROUND OF THE INVENTION

Protective material and protective wear is currently used by persons to protect themselves from knocks, abrasions and other injury. Protective wear is used during sport, rugby for example and equestrian sports and other activities where a person runs a risk of injury, for example building and other trades.

Conventional protective wear may form an integral part of an item of clothing, for example a shoulder pad, or be provided separately, for example a shin pad.

One existing arrangement comprises a moulded foam article shaped to fit a particular part of the body. There are, however, a number of problems with this arrangement. The article must be produced in different sizes to fit different people. Provision of different sizes can be expensive or inconvenient. Also, closely fitting articles can restrict movement of the wearer, especially when worn on or near joints.

In DE 43 41 722 is disclosed a cushioning material for the treatment of lymphostatic fibroses in which a plurality of foam elements with an enlarged base are disposed side-by-side with their bases touching on a foundation layer to which they are affixed. The troughs defined between the side walls of the elements enable the material to be flexed to form a pressure bandage. However, the foam elements of the bandage touch one another at their base, which restricts the stretchability of the material as a whole and is also designed to be worn with the elements in contact with the skin, which would restrict movement.

A moulded foam article can only correctly fit a joint when in one position. When the joint moves, the article will no longer fit correctly. This may reduce the protection it affords.

In U.S. Pat. No. 3,285,768 is disclosed a fabric coated with a surface deformed foam which is manufactured either by grooving or slashing a sheet of foam to a portion of its depth and then laminating it to the fabric or by laminating a foam sheet to a fabric and then grooving or slashing the foam layer. However, neither of these methods enables the foam to be cut to define a plurality of spaced, separate elements, which is preferred if the fabric is to be used in protective wear for sports persons when considerable freedom of movement by the wearer is required in addition to comfort.

Another existing arrangement comprises a quilted material including lengths of foam sewn into pockets formed between two layers of fabric. Such materials are time consuming to produce. Also, such materials can generally only easily be flexed in a direction perpendicular to that of the strips of foam. Flexing the material in a direction along the length of the strips involves flexing the strips themselves which, depending on the type of foam used, can be difficult. A similar type of garment is disclosed in U.S. Pat. No. 5,551,082 which describes an athletic garment in which strategically placed rib-shaped gel, air or foam padding is contained in envelopes that are individually affixed to an elasticized fabric shell.

## BRIEF SUMMARY OF THE INVENTION

It is an object of the present invention to overcome, or at least reduce, the problems associated with the manufacture of conventional protective material and with protective wear made therefrom.

According to a first aspect of the present invention there is provided a method of manufacturing a flexible material comprising the steps of providing a sheet of a resilient material; cutting the sheet into a plurality of spaced, separate elements using a cutter which is pressed into the sheet to cut there-through; making one side of the spaced elements to stand proud of the surface of a jig provided to hold the elements in place; and bonding a flexible, resiliently stretchable substrate to one side of the separate elements by heating the substrate either to activate an adhesive applied between said one side of the separate elements and the substrate or to weld the elements to the substrate.

The separate elements are preferably bonded to the substrate with a hot melt adhesive, although they can be welded thereto using heat to fuse the elements to the substrate.

According to a second aspect of the present invention there is provided a flexible material comprising a layer of separate resilient elements joined to a flexible, resiliently stretchable substrate and manufactured according to the method of the first aspect of the present invention.

Such a flexible material can conform more easily to the body of the wearer than conventional materials, as it is flexible in all three dimensions. It is therefore more comfortable to wear and can accommodate movement better than conventional materials. When used as a protective material or to form protective wear a single size, or a reduced number of sizes, can fit many different sized bodies.

As the elements are separate and spaced apart; this facilitates flexing of the substrate to form a curved surface and enables the material to flex in all directions without "locking up" or preventing movement in a particular direction. This is a particular advantage the flexible material of the present invention has over prior art arrangements which tend not to exhibit universal flexibility.

The elements preferably comprise a resilient foam material, for example a closed cell polyethylene, and could comprise a number of different types of foam or other materials to give desired properties, for example layers of foam of different densities.

The elements may be substantially identical, alternatively they can be of different size and shape, for example to fit comfortably part of a wearer's body, or some other article.

The elements preferably take the form of blocks. They can be of regular or irregular shape, for example hexagonal or octagonal in cross-section. The elements are preferably evenly distributed on the substrate with a density of between

3

100 and 8000 elements/m<sup>2</sup>, more preferably between 250 and 8000 elements/m<sup>2</sup>, and still more preferably between 4000 and 6000 elements/m<sup>2</sup>. In one embodiment, the elements comprise cubes of side 12 mm spaced apart by 2 mm. This gives a density of about 5000 cubes/m<sup>2</sup>. This allows the material to flex easily along all directions, an improvement over known quilted protective materials. Also, one type of material can be cut to many different sizes, for example to form protective wear of different sizes, without significantly affecting its ability to flex. This is in contrast to known quilted protective materials wherein due to the size of the foam strips, the size of each strip must be changed to form an article of different size without reducing flexibility.

The substrate is resiliently stretchable or elastic and preferably comprises a fabric, although a resiliently stretchable film or sheet could be used. This enables the material to adopt a greater range of configurations. Suitable fabrics include knitted nylon and polyester fabrics and more particularly those materials comprising elastane.

A second layer of a flexible substrate material is preferably bonded over the elements so that they are sandwiched between two layers. In this case, as the first substrate layer is resiliently stretchable or elastic, this helps to prevent puckering of one side of the material when it is flexed. Advantageously, both substrate layers are resiliently stretchable. However, in cases where only a single stretchable substrate layer is provided and the material is to be used in a curved configuration the material is preferably arranged so that the stretchable layer lies on the outside surface of the curve.

The material may be comprised in clothing or other wear. It is particularly suitable for incorporation into protective clothing and wear, for example shoulder pads, knee pads, shin pads, arm bands, head-guards, vests and gauntlets for both humans and animals. It will be appreciated that in these garments the blocks are provided where required and omitted from certain areas of the garment. For example, in a headguard no blocks need be positioned in the ear-flaps of the guard.

The material could also be comprised in furniture or upholstery and can be particularly useful when used with wheelchairs and hospital beds. Spaced part elements can help to reduce the incidence of bed sores. As the material is resilient, it comprises a cushioning medium, for,; example for saddles. Where the material comprises a foam layer, this provides it with good thermally insulating properties and it can be usefully incorporated into, or used to form wet suits. A foam layer can also render the material buoyant in water, in which case it can be usefully used in or to form buoyancy vests, life jackets and swimming aids. When used as a swimming aid, for example, the material can be incorporated in swimming costumes as an aid to the buoyancy of the wearer. It is possible in this case to arrange for the foam blocks to be progressively removable from the costume as the confidence and skill or the trainee swimmer increases.

The material may also be used for packaging and cladding.

As indicated above, the elements may not be distributed all over the surface of the substrate. In particular, there may be a border of substrate having no element thereon. The border may include a fastening means, for example VELCRO<sup>(TM)</sup> to enable it to be affixed to itself or to another article, say a garment.

In one embodiment, the elements could comprise a series of spaced-apart strips. Such a material would have different properties when flexed in different directions.

4

Preferably, at least said one side of the elements are coated with the hot-melt adhesive prior to being cut into the separate elements. Alternatively or in addition, the side of the substrate adjacent said one side of the elements is coated with the hot-melt adhesive. A sheet of hot-melt film may also be interposed between said one side of the elements and the substrate to provide said adhesive layer.

Advantageously, the resilient sheet is cut into a plurality of separate elements using a cutter which acts as the jig after cutting through the resilient material to hold the elements in place while the substrate layer is applied thereto. Preferably, the cutter is adapted so that said one side of each, now cut, element are made to stand proud of the surface of the cutter grid. The sheet material may spring back slightly after cutting to accomplish this. Alternatively, means, such as ejectors, are provided to achieve this effect.

In one embodiment of the method, a sheet of a resilient material is provided and at least one side of the sheet is coated with a hot melt adhesive. The sheet is placed, adhesive side up, over a cutter grid arranged to cut the sheet into a plurality of elements, for example squares. The sheet is pressed down onto the cutter to cut through the sheet. Excess material from between the elements is then removed. A resiliently stretchable substrate is placed over the, now cut, sheet and heated to activate the adhesive to join the elements to the substrate. The substrate is then lifted away from the cutter, taking the elements with it.

It will be appreciated that in this embodiment, the cutter grid acts as a jig, holding the elements in place while the substrate layer is applied. If the flexible material is to be cut into large pieces, in particular large irregularly shaped pieces, then these pieces may be assembled into a specially constructed jig to hold them into place before application of the substrate. Conveniently, as before the sheet of resilient material from which the elements are cut has an adhesive layer applied to one or both surfaces prior to the cutting process.

Alternatively, the sheet of resilient material is cut into strips in a first direction using a plurality of rolling cutters and then cut in a second direction at an angle to the first direction to the separate elements. Preferably, the rolling cutters are moved sideways after each cut to cut narrow strips of material in both directions to space the elements apart, the narrow strips of material being removed to leave the separate elements spaced apart from one another.

#### BRIEF DESCRIPTION OF THE SEVERAL VIEWS OF THE DRAWINGS

Embodiments of the various aspects of the invention will now be described by way of example with reference to the accompanying drawings.

FIG. 1 is an enlarged perspective view of part piece of flexible material according to the invention.

FIG. 2 shows a schematic view of a protective arm band formed from the type of material of FIG. 1.

FIG. 3 is a plan view of a cutter grid.

FIGS. 4 to 6 are vertical cross-sectional views of apparatus used in the manufacture of material as shown in FIG. 1 at various stages respectively throughout the manufacturing process.

FIG. 7 is a cross-sectional view through another embodiment of a flexible material according to the invention.

#### DETAILED DESCRIPTION OF THE INVENTION

Referring to FIG. 1, a flexible material comprises a plurality of cubes 1 of a resilient closed-cell polyethylene foam, of

5

side approximately 12 mm and with corners of radius approximately 2.5 mm, joined with a hot melt adhesive to a fabric substrate 2. The cubes 1 are evenly arranged, each cube being spaced from adjacent cubes by approximately 2 mm. The fabric 2 is a resiliently stretchable knitted fabric, preferably one comprising polyester or elastane fibers.

A margin of fabric 2 is provided around the periphery of the cubes 1. Along the edges of the fabric at opposite ends respectively there are strips 3 of VELCRO™, only one of which is shown.

Referring to FIG. 2, a protective armband 4 is shown being worn on part of an arm 5. The armband 4 is formed from a generally rectangular piece of material of the type shown in FIG. 1 but which in this case comprises a fabric substrate 6 bonded to both sides thereof with a plurality of foam cubes 7 sandwiched therebetween. Margins are provided at opposite ends respectively of the substrate 6 and a strip of VELCRO™ 8 is fastened on this margin to enable opposite ends of the material to be fastened in an overlaying relationship to form a tube. By varying the degree of overlap of the ends, the tube can be closely fitted around arms of different sizes. The provision of a substrate layer 6 on both sides of the cubes 7 prevents the latter from separating too much as the material is curved around to form a tube. Rather, the substrate 6 on the outside of the armband is forced to stretch and the edges of the cubes 7 at the inner side of the armband are compressed. The provision of a substrate layer on both sides of the material therefore enables the material to continue to provide good protection, even when tightly flexed.

FIG. 3 shows a plan view of a cutter used for manufacturing the material of FIG. 1. The cutter comprises blades defining a plurality of squares of 12 mm side with corners of radius 2.5 mm.

FIGS. 4 to 6 are vertical cross-sectional views of apparatus at various stages respectively throughout the manufacture of the flexible material shown in FIG. 1. Referring to these figures, one side of a 12 mm thick layer of closed cell polyethylene foam 10 is coated with a hot melt adhesive 11. The foam 10 is then placed onto a cutter 12, of the type shown in FIG. 3, and pressed down with a press 13 so that the cutter 12 cuts through the foam 10 to form a plurality of separate cubes. The press is then removed, whereupon owing to its resilient nature, the foam will tend to spring back slightly so that the exposed surface of each cube stands proud to lie above the surface of the cutter. Excess material from between the elements is then removed.

Next, as shown in FIG. 5, a layer of fabric is placed over the foam and cutter 12 and a heated platen 15 is brought into contact with the fabric 14. Heat is conducted through the fabric 14 to the foam and activates the adhesive, bonding the fabric 14 to the foam 10. In this arrangement, the cutter grid acts as a jig, holding the foam cubes in position whilst the fabric substrate 14 is applied thereto.

Then, as shown in FIG. 6, the fabric can be lifted away from the cutter taking the foam cubes 10 with it.

In an alternative method, ejectors are disposed in the cutter grid to eject the elements, leaving any waste material behind in the cutters.

If the foam 10 is to be cut into large pieces, in particular large irregularly shaped pieces such as may be suitable for use in an equestrian jacket, then these pieces may be assembled into a specially constructed jig to hold them into place before application of the fabric substrate 14. As described above, the sheet of resilient foam from which the elements are cut will have hot-melt adhesive applied to one or both surfaces prior to the cutting process.

6

In a further variation, the sheet of resilient material is cut into strips in a first direction using a plurality of rolling cutters. The sheet is cut in a second direction perpendicular to the first to form cubes. The cutters are then moved sideways to cut narrow strips of foam in both directions to space the cubes apart, the narrow strips of foam being stripped away to leave the cubes.

FIG. 7 shows another embodiment of flexible material similar to that shown in FIG. 1, but with a layer of fabric 16 bonded to each of opposite sides of the elements 17. This embodiment may be produced in a similar way to that shown in FIG. 1 except that opposite sides of the foam layer are coated with adhesive and, after the foam cubes bonded to a first layer of fabric have been removed from the cutter, a second layer of fabric is placed over the exposed surface of the elements are pressed with a heated platen to effect a bond.

In other variations to the above methods, the hot-melt adhesive may be applied to the surface the substrate rather or in addition to the sides of the flexible material. Alternatively or in addition, a hot-melt film can be interposed between the elements and the substrate.

Also, heated nip-rollers can be used in place of a heated platen to bond the elements to the substrate, particularly when substrate is bonded to both sides of the elements, which are thereby sandwiched therebetween. This facilitates passage of the material between the rollers prior to activation of the adhesive.

Flexible materials according to the invention are more convenient to produce and more flexible and versatile than known protective materials. They may also be used in a variety of applications including protective wear and clothing.

I claim:

1. A method of manufacturing a flexible material comprising the steps of providing a sheet of a resilient material;

cutting the sheet into a plurality of spaced separate elements using a cutter which is pressed into the sheet to cut therethrough;

making one side of the plurality of spaced separate elements to stand proud of a surface of a jig provided to hold the elements in place; and

bonding a flexible resiliently stretchable substrate to one side of the separate elements by heating the substrate either to activate an adhesive applied between said one side of the separate elements and the substrate or to weld the separate elements to the substrate.

2. The method as claimed in claim 1 wherein the sheet is cut into a plurality of separate elements using a cutter which acts as the jig after cutting through the resilient material to hold the elements in place while the substrate is applied thereto.

3. The method as claimed in claim 2, wherein the cutter is adapted so that said one side of each of the cut elements is made to stand proud of a surface of the cutter after cutting through said sheet of resilient material.

4. The method as claimed in claim 3, wherein any excess resilient material located between the plurality of spaced separate elements is retained in the cutter.

5. The method as claimed in claim 3, wherein any excess resilient material is removed from between the plurality of spaced separate elements prior to the elements being bonded to the substrate.

6. The method as claimed in any of claim 1, wherein the plurality of spaced separate elements comprise a foam material.



7

7. The method as claimed in claim 1, further comprising:  
bonding a second flexible substrate to an opposite side of  
the plurality of spaced separate elements to said one  
side.

8. The method as claimed in claim 1, wherein at least said  
one side of the sheet is coated with a hot-melt adhesive prior  
to being cut into the plurality of spaced separate elements.

9. The method as claimed in claim 1, wherein the side of  
the substrate adjacent said one side of the plurality of spaced  
separate elements is coated with a hot-melt adhesive.

10. The method as claimed in claim 1, wherein a sheet of  
hot-melt film is interposed between said one side of the plu-  
rality of spaced separate elements and the substrate so as to  
provide said adhesive.

11. The method as claimed in claim 1, wherein the sheet  
of resilient material is cut into strips in a first direction using  
a plurality of rolling cutters and then cut in a second direc-  
tion at an angle to the first direction to form the plurality of  
spaced separate elements.

12. The method as claimed in claim 11 wherein the rolling  
cutters are moved sideways after each cut to cut narrow  
strips of material in both directions to space the elements  
apart, the narrow strips of material being removed to leave  
the plurality of spaced separate elements spaced from one  
another.

13. The method as claimed in claim 1 wherein the sub-  
strate is heated by a heated platen which either activates the  
adhesive or melts the surface and thereby bonds the substrate  
and the plurality of spaced separate elements together.

14. The method as claimed in claim 10, wherein the sub-  
strate is heated by passing the substrate and the adjacent  
plurality of spaced separate elements between heated nip  
rollers.

15. *A method of manufacturing a flexible resiliently com-  
pressible material comprising:*

*providing a first resiliently stretchable fabric substrate;  
providing an array of a plurality of separate individual  
resiliently compressible elements in a spaced  
relationship, the individual elements having a top sur-  
face and bottom surface in an array of top surfaces and  
bottom surfaces;*

*providing a second resiliently stretchable fabric sub-  
strate;*

*contacting the top surfaces and the bottom surfaces of the  
plurality of resiliently compressible elements with the  
first and second resiliently stretchable fabric sub-  
strates; and*

*bonding the top and bottom surfaces of compressible ele-  
ments to the first and second resiliently stretchable fab-  
ric substrates so that the elements will be held in a  
spaced apart relation with spaces between the  
elements, the bonding selected from the group consist-  
ing of adhesively bonding and welding, the fabric sub-  
strates not bonded to each other in the spaces of about  
2 mm and to provide the flexible resiliently compress-  
ible material, wherein a sheet of resiliently compress-  
ible material is cut into the plurality of separate indi-  
vidual resiliently compressible elements using a cutter  
which acts as a jig after cutting through the resiliently  
compressible material to hold the elements in place  
while contacting one of the substrates to the elements.*

16. *The method as claimed in claim 15 wherein the plural-  
ity of individual resiliently compressible elements comprises  
a foam material.*

17. *The method according to claim 16 wherein the foam  
material comprises layers of foam having different densities.*

8

18. *The method according to claim 15 wherein the ele-  
ments are distributed between the substrates at a density of  
from about 4000 to about 6000 elements/m<sup>2</sup>.*

19. *The method according to claim 18 wherein the top and  
bottom surfaces have a polygonal shape.*

20. *A method of manufacturing a flexible resiliently com-  
pressible material comprising:*

*providing a first resiliently stretchable fabric substrate;*

*cutting a sheet of resiliently compressible foam with a  
cutter to provide an array of a plurality of separate  
individual resiliently compressible foam elements in a  
spaced apart relationship, the cutter acting as a jig  
after cutting through the resiliently compressible foam  
to hold the elements in place, the individual elements  
having a planar top surface and bottom surface in an  
array of top surfaces and bottom surfaces;*

*providing a second resiliently stretchable fabric sub-  
strate;*

*contacting the top surfaces and the bottom surfaces of the  
plurality of resiliently compressible elements with one  
of the first and second resiliently stretchable fabric sub-  
strates while the cutter holds the elements in place; and*

*adhesively bonding the top and bottom surfaces of com-  
pressible elements to the first and second resiliently  
stretchable fabric substrates so that the elements will  
be held in a spaced apart relation with spaces between  
the elements, the fabric substrates not bonded to each  
other in the spaces and to provide the flexible resiliently  
compressible material.*

21. *The method according to claim 20 wherein the foam  
elements comprise foam with of layers of foam having differ-  
ent densities.*

22. *A method of manufacturing a flexible resiliently com-  
pressible material comprising:*

*providing a first resiliently stretchable fabric substrate;*

*cutting a layer of foam with a cutter grid having cutting  
edges which go completely through the foam layer to  
provide an array of a plurality of separate cut indi-  
vidual resiliently compressible elements which have  
been cut from the foam and after cutting are in a spaced  
apart relationship, the individual elements being spaced  
about 2 mm from each other, the array of elements hav-  
ing top and bottom surfaces;*

*bonding one of the surfaces of the array of the plurality of  
separate cut individual resiliently compressible ele-  
ments to the first resiliently stretchable fabric substrate  
while the separate cut individual elements are held in  
the spaced apart relationship with a jig to provide a  
fabric element combination, the elements of the fabric  
element combination held in spaced bonded relation-  
ship;*

*providing a second resiliently stretchable fabric sub-  
strate;*

*bonding the second resiliently stretchable fabric substrate  
to the elements of the fabric element combination to the  
elements on the side of the array opposite the first fab-  
ric substrate so that the elements will be held in a  
spaced apart relation between the first and second  
resiliently stretchable fabric substrates with spaces  
between the elements, the fabric substrates not bonded  
to each other in the spaces and to provide the flexible  
resiliently compressible material.*

9

23. The method according to claim 22 wherein the elements are distributed between the substrates at a density of from about 250 to about 8000 elements/m<sup>2</sup> between the substrates.

24. The method according to claim 23 wherein the elements are comprised of layers of foam having different densities.

10

25. The method according to claim 22 wherein the elements are distributed between the substrates at a density of from about 4000 to about 8000 elements/m<sup>2</sup> between the substrates.

\* \* \* \* \*

UNITED STATES PATENT AND TRADEMARK OFFICE  
**CERTIFICATE OF CORRECTION**

PATENT NO. : RE 41,346 E  
APPLICATION NO. : 11/269919  
DATED : May 25, 2010  
INVENTOR(S) : David Stirling Taylor

Page 1 of 1

It is certified that error appears in the above-identified patent and that said Letters Patent is hereby corrected as shown below:

Column 1, line 50, change "foram" to -- foam --

Column 1, line 66, change "for ,sports" to -- for sports --

Column 2, line 30, change "active" to -- activate --

Column 2, line 41, change "confirm" to -- conform --

Column 3, line 45, change "for,;" to -- for --

Column 8, line 44, change "elevens" to -- elements --

Signed and Sealed this

Twenty-fourth Day of August, 2010

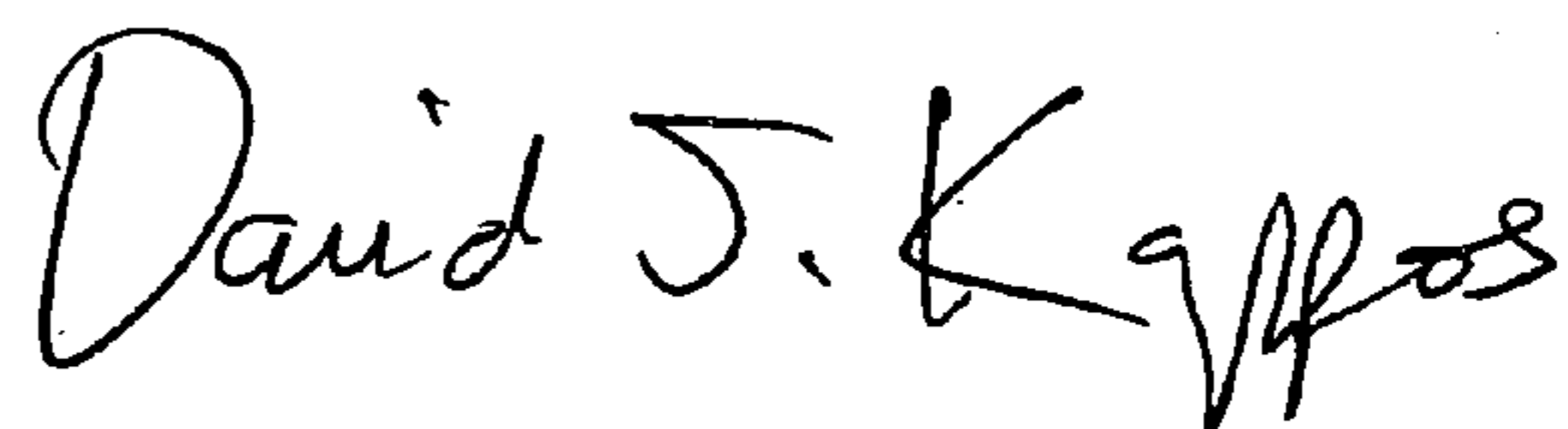
A handwritten signature in black ink that reads "David J. Kappos". The signature is written in a cursive style with a large, prominent 'D' and 'K'.

David J. Kappos  
*Director of the United States Patent and Trademark Office*