

US00RE41260E

(19) **United States**
(12) **Reissued Patent**
Hu

(10) **Patent Number:** **US RE41,260 E**
(45) **Date of Reissued Patent:** **Apr. 27, 2010**

(54) **RETAINER RING FOR SECURELY
RETAINING A FIRST OBJECT TO A SECOND
OBJECT**

(76) Inventor: **Bobby Hu**, 8F, No. 536-1, Ta Chin
Street, Taichung (TW)

(21) Appl. No.: **11/366,985**

(22) Filed: **Mar. 2, 2006**

Related U.S. Patent Documents

Reissue of:

(64) Patent No.: **6,698,320**
Issued: **Mar. 2, 2004**
Appl. No.: **10/102,658**
Filed: **Mar. 21, 2002**

(51) **Int. Cl.**
B23B 23/00 (2006.01)

(52) **U.S. Cl.** **81/438**

(58) **Field of Classification Search** 81/438,
81/439, 177.85, 177.5, 490, 125.1
See application file for complete search history.

4,459,716 A	7/1984	Valadez	7/100
4,480,511 A	11/1984	Nickipuck	81/177
4,520,697 A	6/1985	Moetteli	81/62
4,699,029 A	10/1987	Kelly et al.	81/121.1
4,787,278 A	11/1988	Bononi	81/438
5,042,333 A	8/1991	Huang	81/438
5,067,775 A	11/1991	D'Angelo	299/86
5,136,902 A	8/1992	Ma	81/119
5,218,891 A	6/1993	Olson et al.	81/125.1
5,230,263 A	7/1993	Kwaka	81/125.1
5,295,422 A	3/1994	Chow	81/124.3
5,307,713 A	5/1994	White	81/180.1
5,640,889 A	6/1997	Anderson	81/125
5,791,848 A	8/1998	Lanham	411/373
5,842,394 A	12/1998	Hwang	81/439
5,865,074 A	2/1999	Hsieh	81/124.3
5,918,512 A	7/1999	Habermehl et al.	81/438
5,946,989 A	9/1999	Hsieh	81/124.3
5,975,186 A	11/1999	Day	160/321
6,305,255 B1	10/2001	Wu	81/439
6,332,382 B1	12/2001	Anderson et al.	81/438
6,494,121 B1 *	12/2002	Hu	81/439
6,634,261 B1	10/2003	Griffin	81/124.1
6,691,593 B2	2/2004	Hu	81/60
6,698,320 B2 *	3/2004	Hu	81/438
6,701,808 B2	3/2004	Hsieh	81/124.3
6,860,176 B1	3/2005	Hsien	81/124.1

* cited by examiner

Primary Examiner—Lee D Wilson

(74) *Attorney, Agent, or Firm*—Alan Kamrath; Kamrath & Associates PA

(57) **ABSTRACT**

A resilient retainer ring comprises at least two pressing sections and at least one engaging section. Each pressing section presses against a bottom wall defining an annular groove in a receiving compartment of a screwdriver shank when the retainer ring is mounted in the annular groove of the screwdriver shank. The engaging section is exposed to at least one corner of the receiving compartment such that the engaging section has at least a portion engaged in a retaining groove of a bit when an end of the bit is received in the receiving compartment of the screwdriver shank.

28 Claims, 8 Drawing Sheets

(56) **References Cited**

U.S. PATENT DOCUMENTS

1,384,655 A	7/1921	Allmon	81/124.3
1,936,352 A	11/1933	Dixon	81/119
2,320,044 A	5/1943	Merriman	81/125
2,488,894 A	11/1949	Barrett	81/124.1
2,671,368 A	3/1954	Diebold	81/119
2,727,418 A	12/1955	Moon	81/121
2,751,802 A	6/1956	Ruillard	81/121
2,769,360 A	11/1956	Cottrell et al.	81/121
2,774,259 A	12/1956	Caulkins	76/114
2,801,561 A	8/1957	Bonner	81/90
2,805,594 A	9/1957	Fogel	81/125
2,806,706 A	9/1957	Fitch	279/79
2,880,637 A	4/1959	Koenig	81/10
3,347,293 A	10/1967	Clark	145/50
4,096,896 A	6/1978	Engel	145/50 B
4,139,036 A	2/1979	Regan et al.	145/46
4,324,158 A	4/1982	Le Roy	81/60

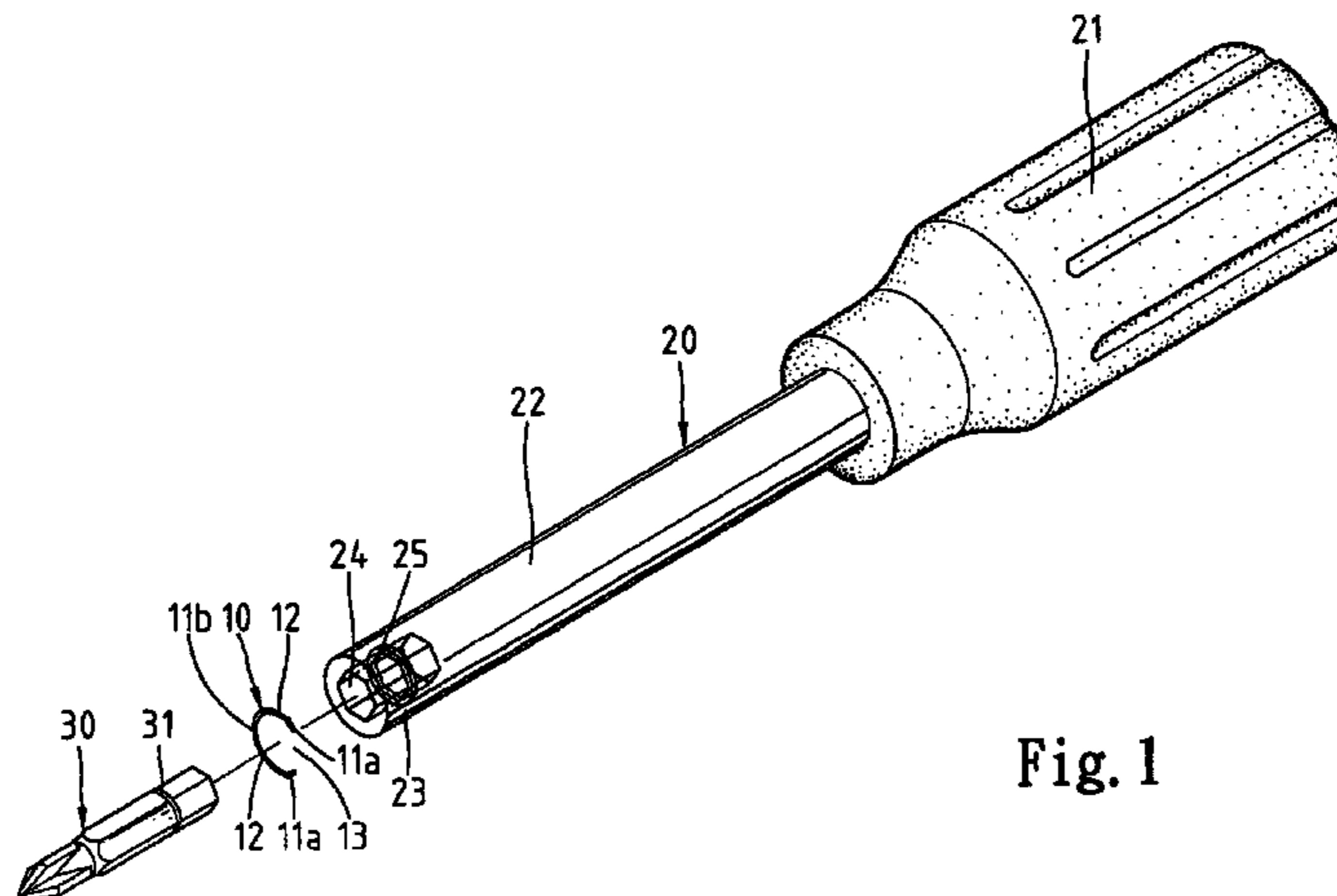
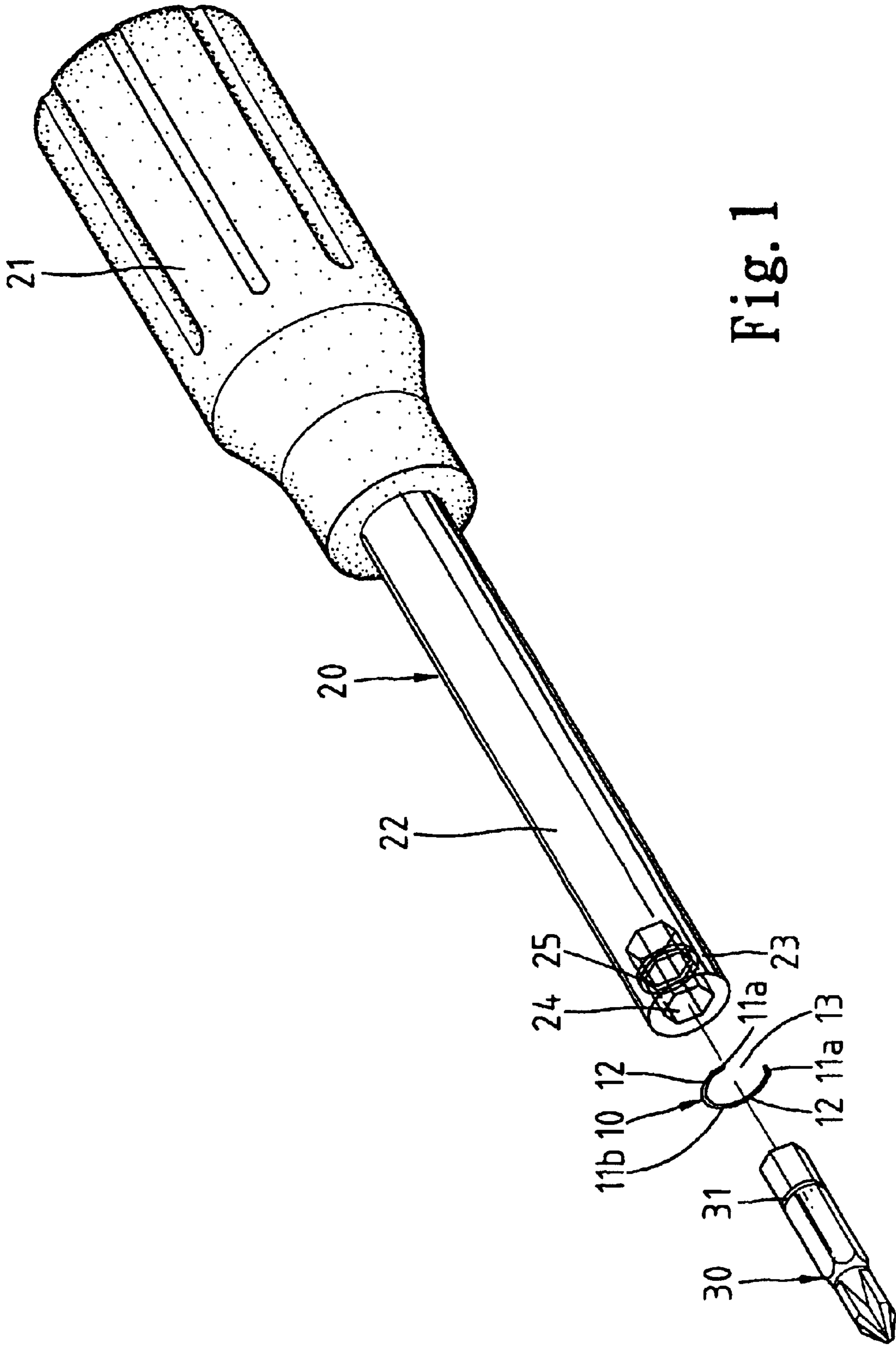

Fig. 1



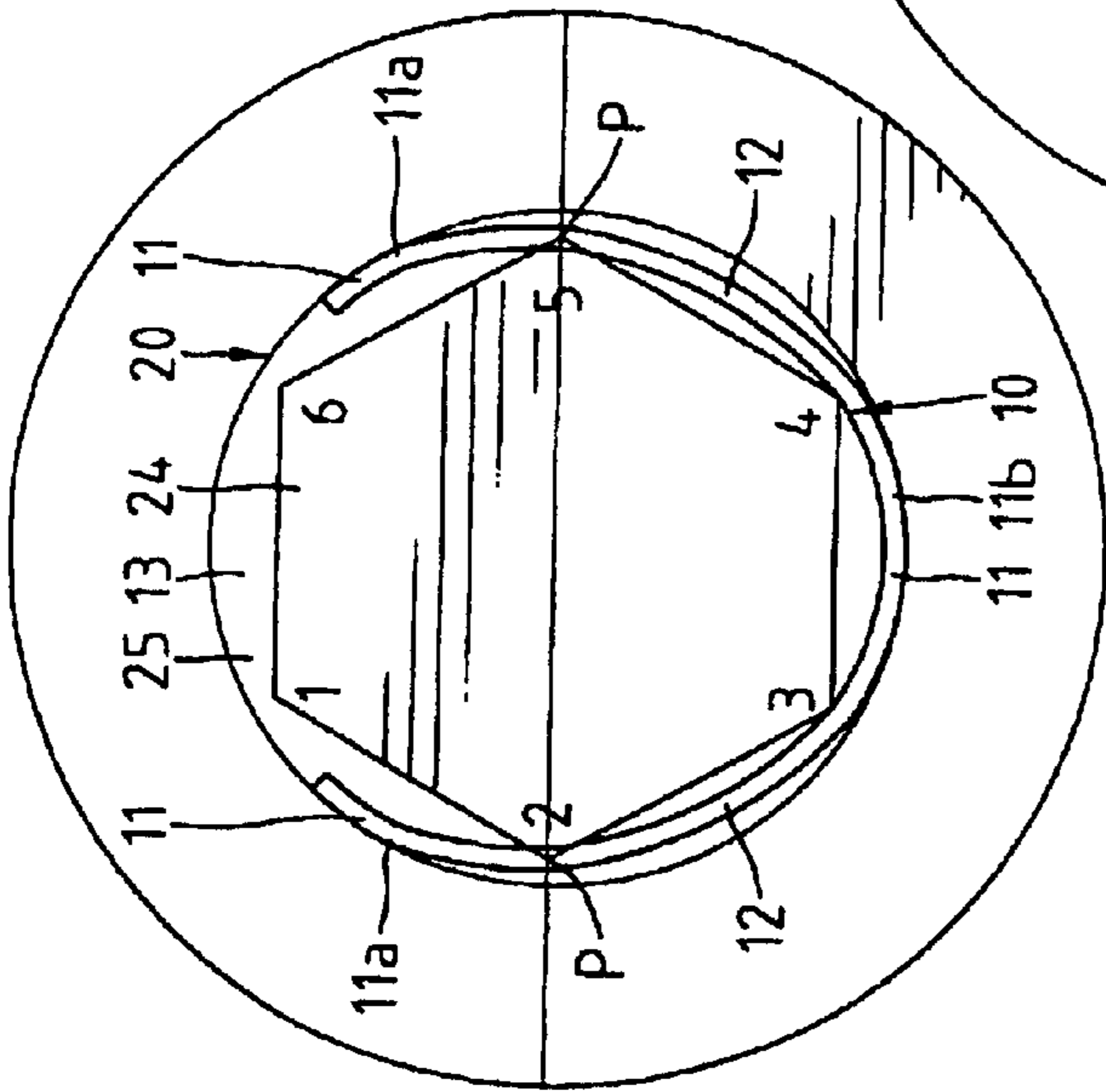

Fig. 2A

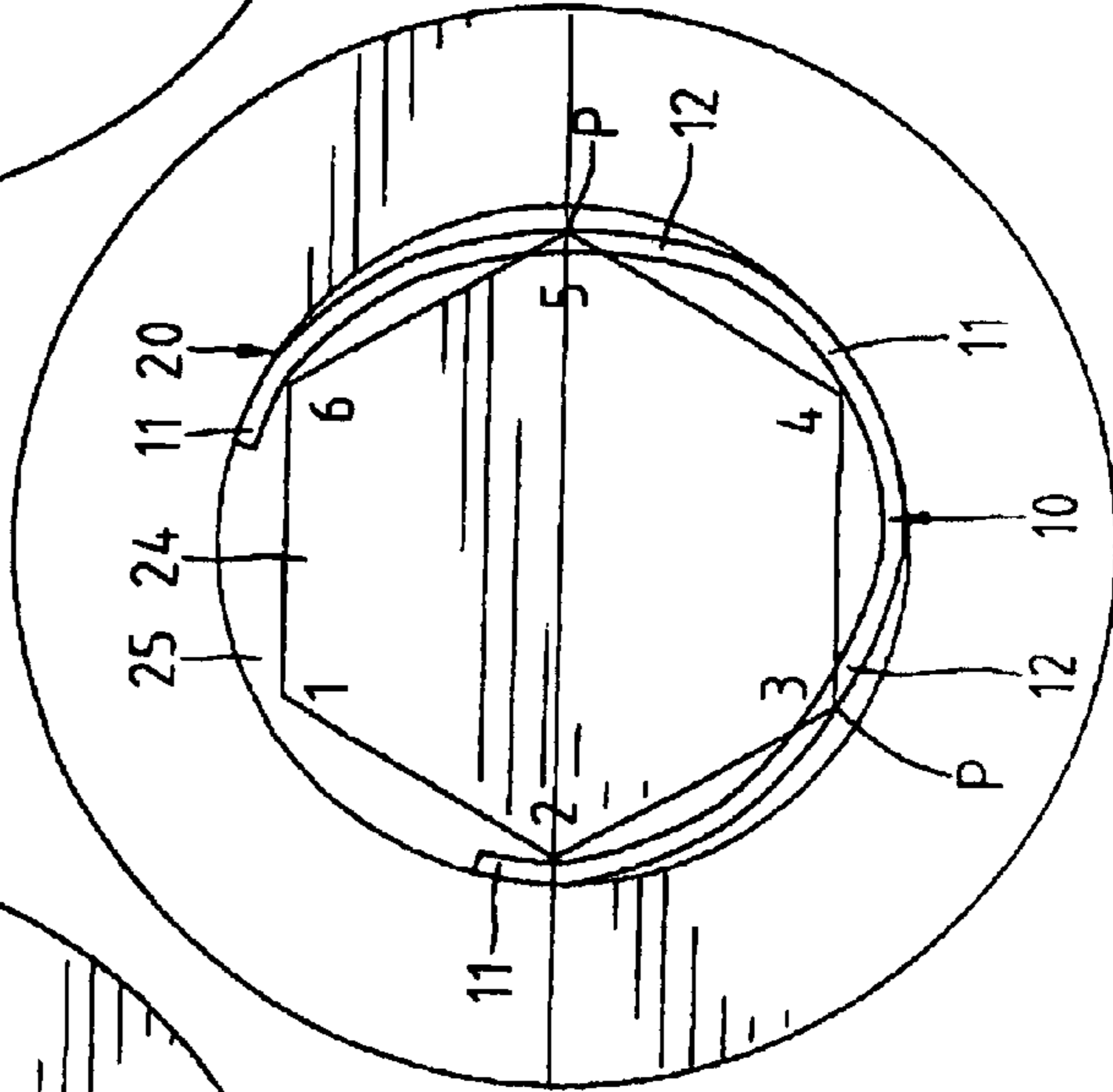

Fig. 2B

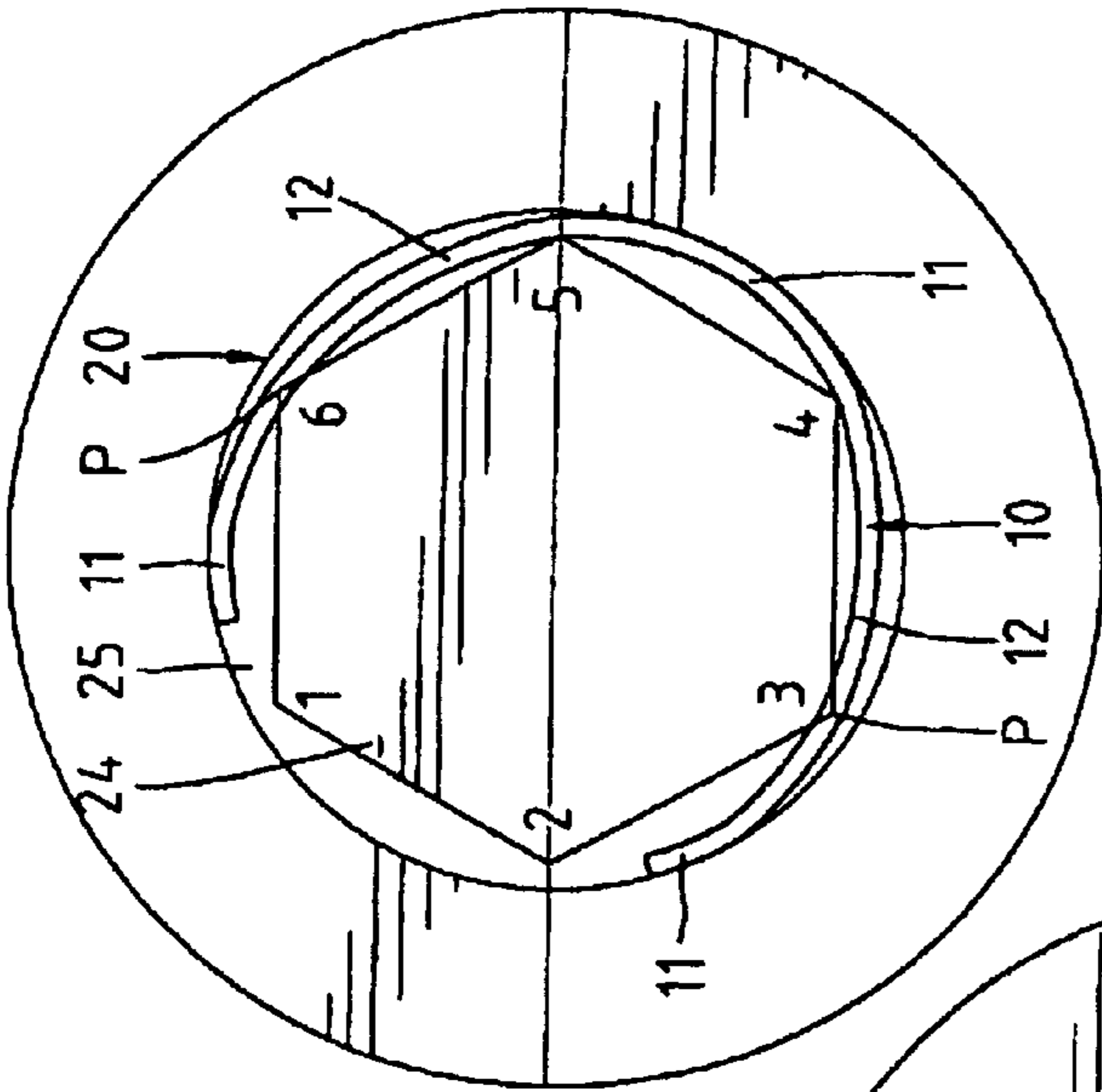

Fig. 2C

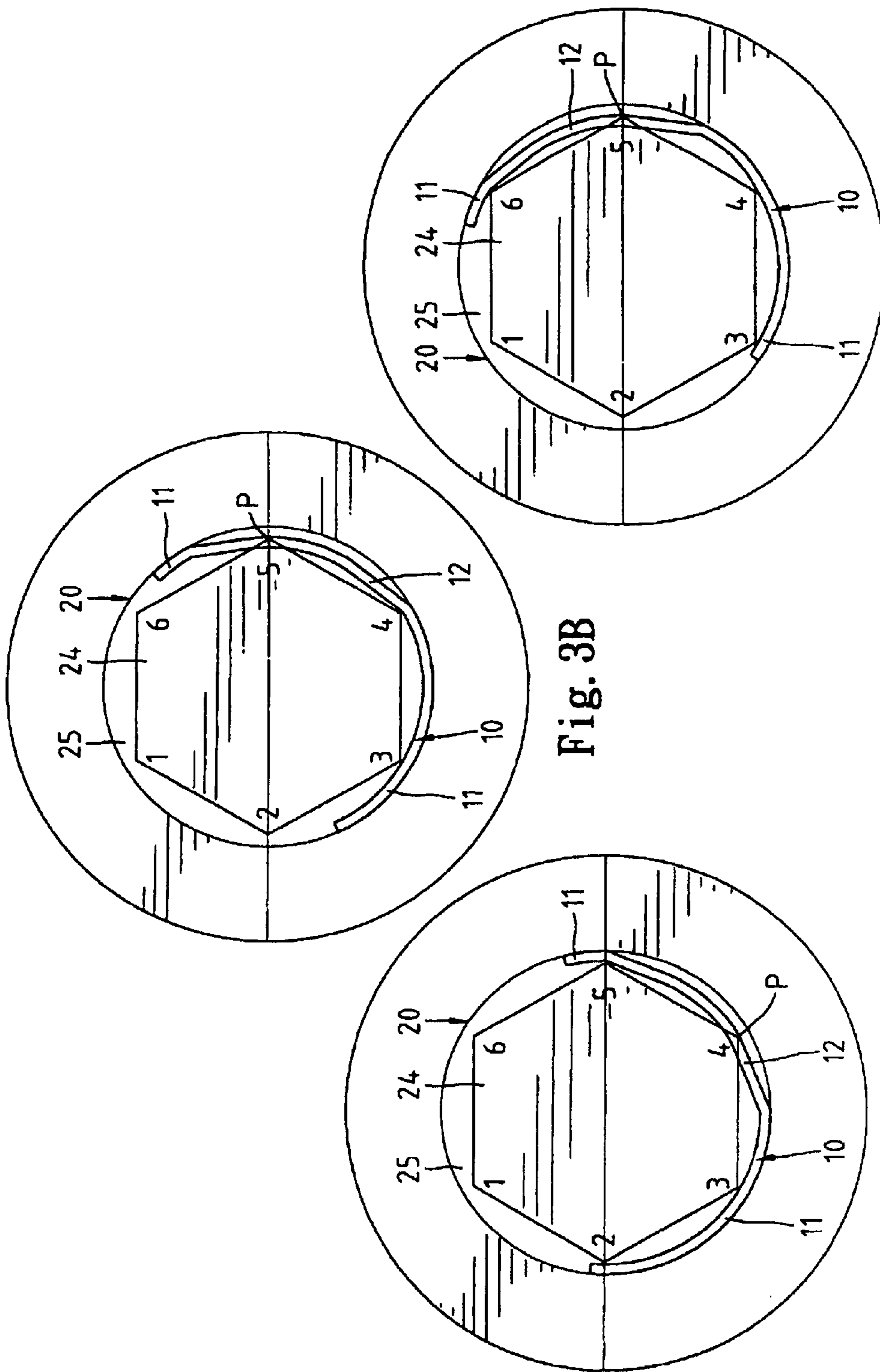

Fig. 3B

Fig. 3C

Fig. 3A

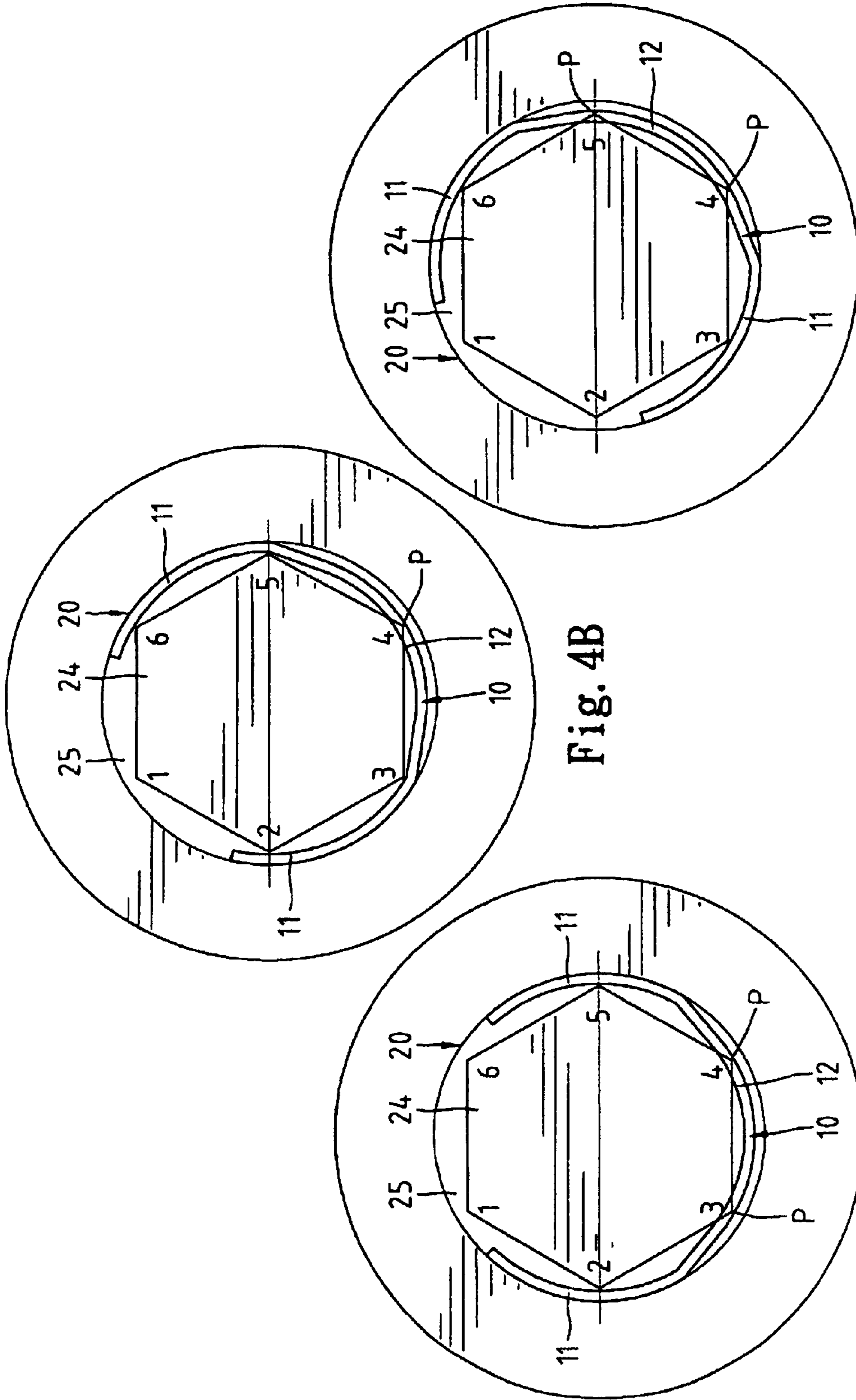

Fig. 4C

Fig. 4B

Fig. 4A

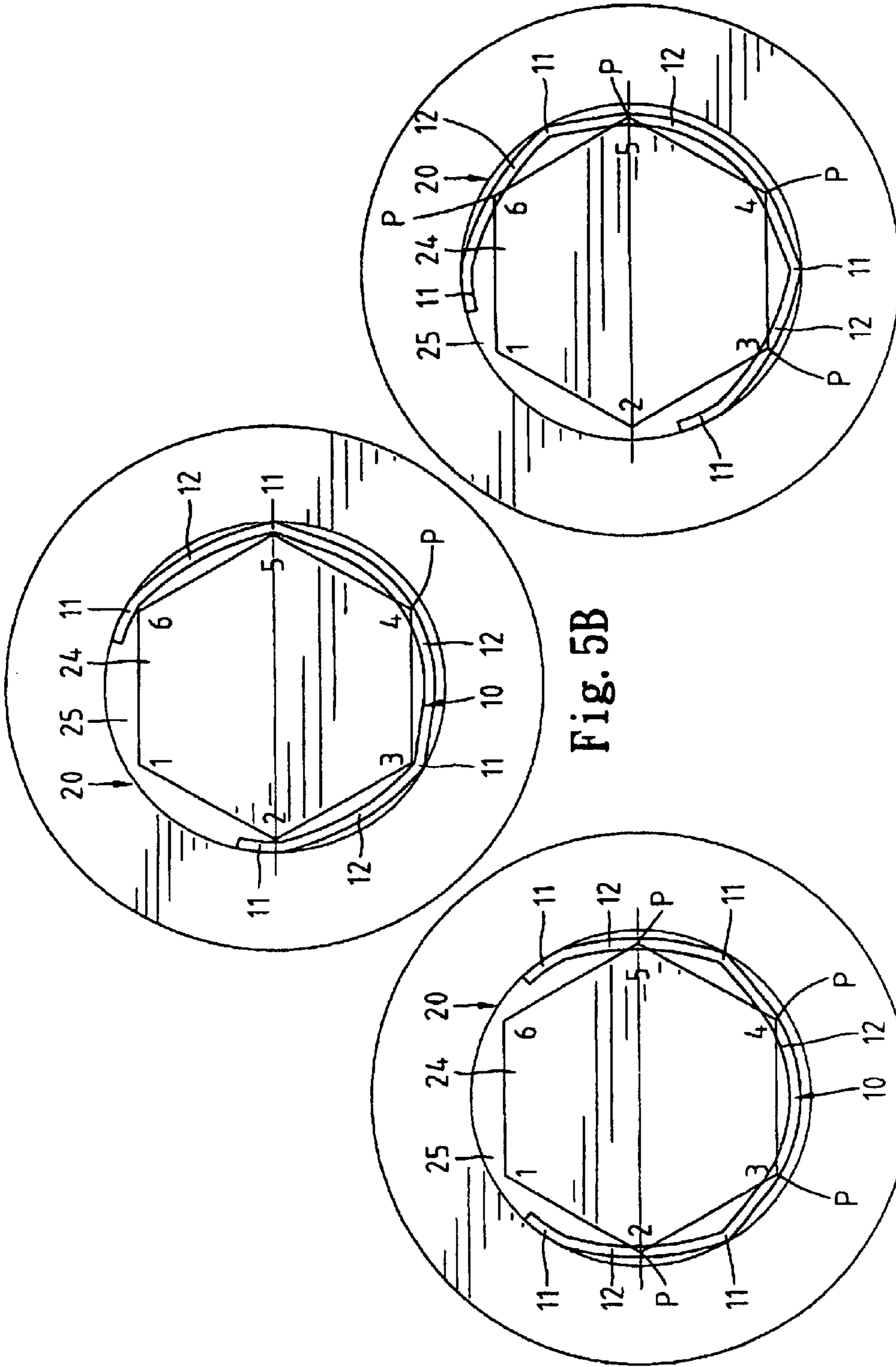

Fig. 5C

Fig. 5B

Fig. 5A

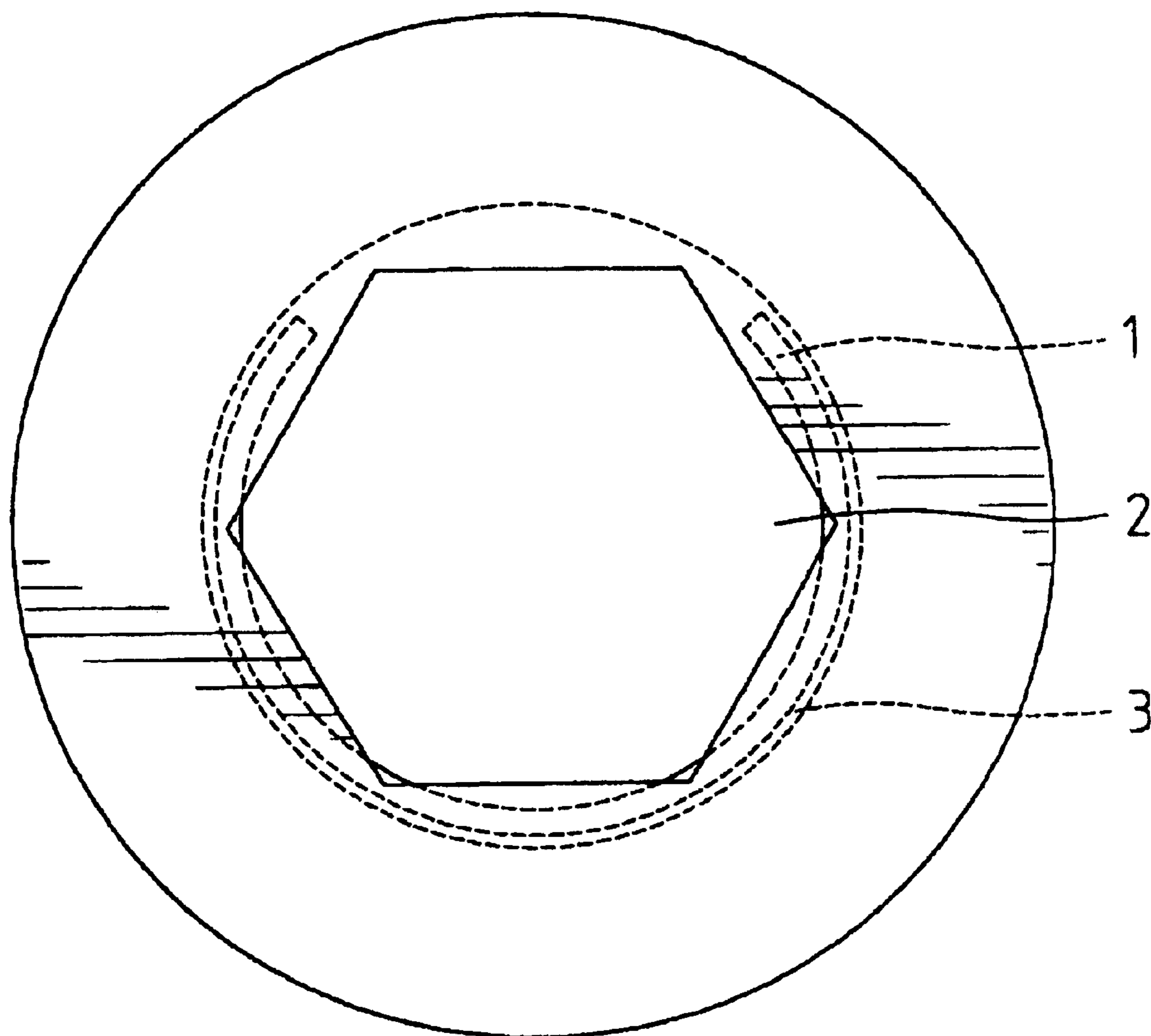

Fig. 6A
PRIOR ART

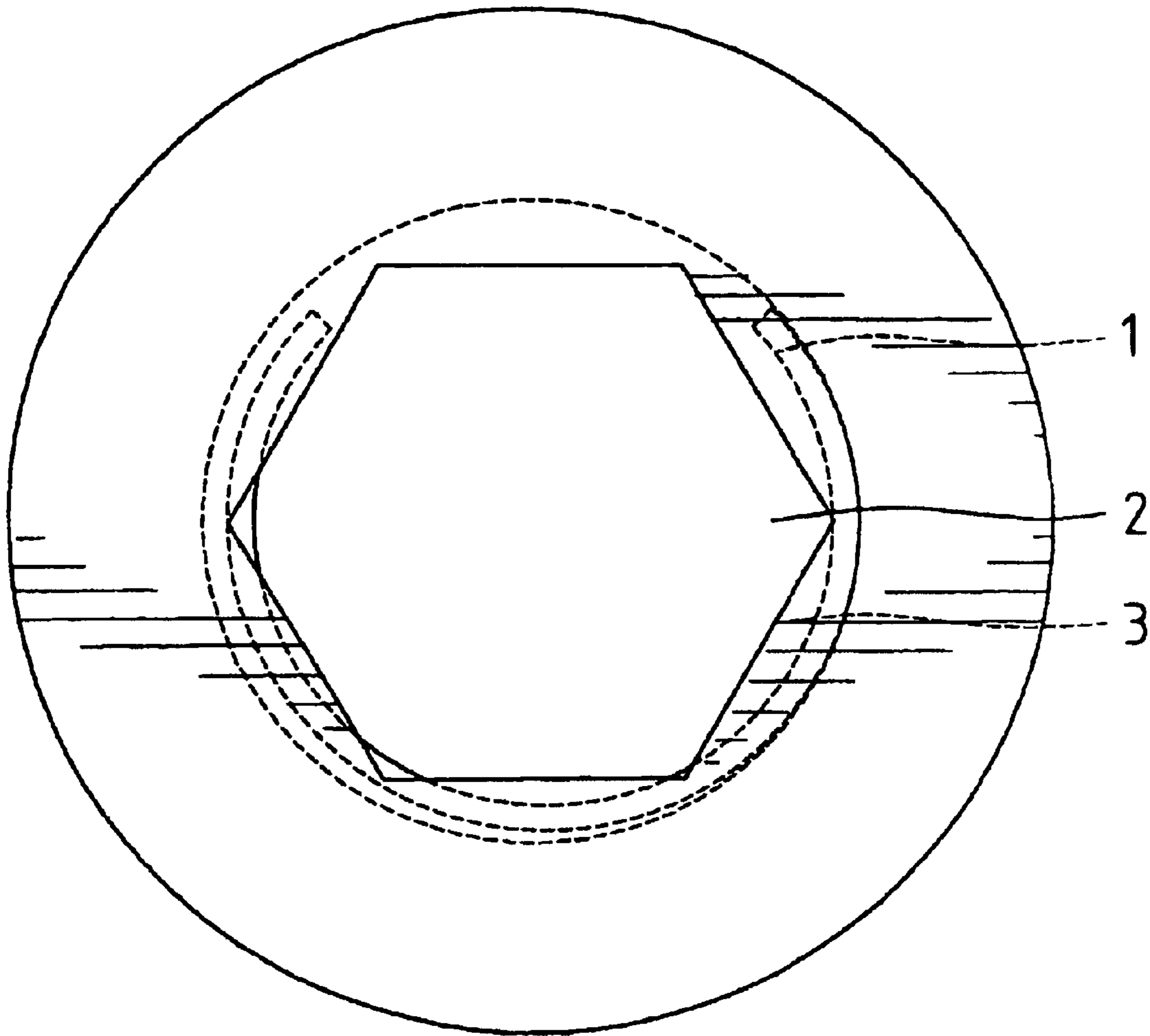

Fig. 6B
PRIOR ART

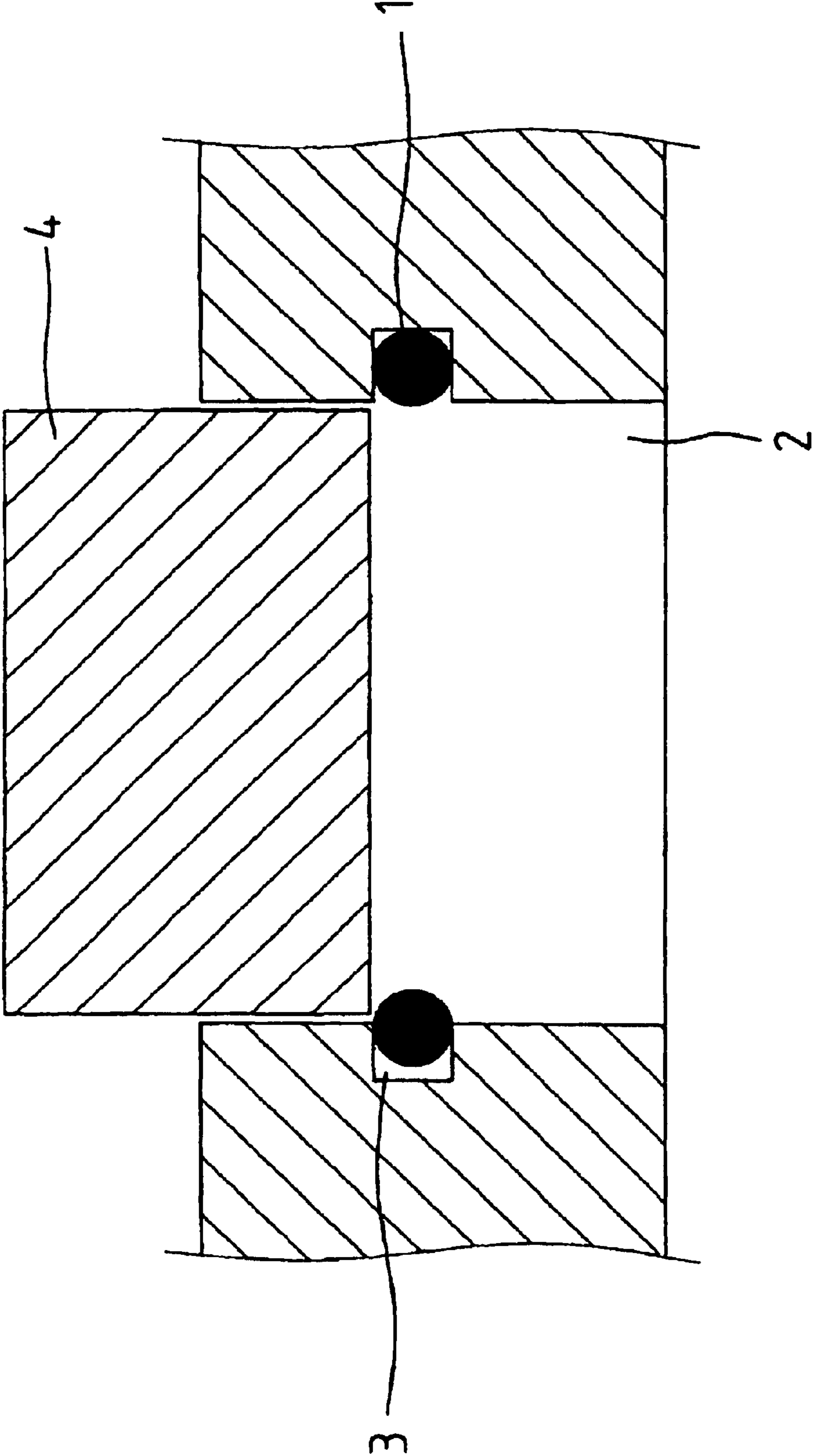

Fig. 7
PRIOR ART

1

RETAINER RING FOR SECURELY RETAINING A FIRST OBJECT TO A SECOND OBJECT

Matter enclosed in heavy brackets [] appears in the original patent but forms no part of this reissue specification; matter printed in italics indicates the additions made by reissue.

BACKGROUND OF THE INVENTION

1. Field of the Invention

The present invention relates to a retainer ring for securely retaining a first object, e.g., a bit, to a second object, e.g., a shank of a screwdriver.

2. Description of the Related Art

FIG. 6A of the drawings illustrates a conventional retainer ring **1** engaged in an annular groove **3** defined in an inner periphery of a receiving compartment **2** of an object, e.g., a screwdriver shank. After mounting in the annular groove **3**, the retainer ring **1** could move to a position shown in FIG. 6B under the action of gravity. This is because there is no means for securely retaining *the* retainer ring **1** in the annular groove **3**. As a result, as illustrated in FIG. 7, it would be impossible to mount a bit **4** into the receiving compartment **2**, as the retainer ring **1** protrudes too much outward to be inserted into the receiving compartment **2**.

SUMMARY OF THE INVENTION

An object of the present invention is to provide a retainer ring for securely retaining a first object, e.g., a bit, to a second object, e.g., a screwdriver shank.

In accordance with the present invention, a combination of a first object, a second object, and a retainer ring is provided. The combination comprises a first object including a retaining groove in an end thereof, a second object including a receiving compartment for removably receiving the end of the first object, and a resilient retainer ring. The receiving compartment has a plurality of corners. An annular groove is defined in an inner periphery defining the receiving compartment. The resilient retainer ring is received in the annular groove of the second object and includes at least two pressing sections and at least one engaging section. Each pressing section presses against a bottom wall defining the annular groove of the second object. The engaging section is exposed to at least one corner of the receiving compartment such that the engaging section has at least a portion engaged in the retaining groove when the end of the first object is received in the receiving compartment.

Other objects, advantages, and novel features of the invention will become more apparent from the following detailed description when taken in conjunction with the accompanying drawings.

BRIEF DESCRIPTION OF THE DRAWINGS

FIG. 1 is an exploded perspective view of a screwdriver, a bit, and a retainer ring in accordance with the present invention.

FIG. 2A is a sectional view illustrating engagement of the retainer ring and a shank of the screwdriver.

FIG. 2B is a view similar to FIG. 2A, wherein the retainer ring is rotated 30° in a counterclockwise direction.

FIG. 2C is a view similar to FIG. 2A, wherein the retainer ring is rotated 60° in a counterclockwise direction.

FIG. 3A is a sectional view illustrating engagement of a modified embodiment of the retainer ring and a shank of the screwdriver.

2

FIG. 3B is a view similar to FIG. 3A, wherein the retainer ring is rotated 30° in a counterclockwise direction.

FIG. 3C is a view similar to FIG. 3A, wherein the retainer ring is rotated 60° in a counterclockwise direction.

FIG. 4A is a sectional view illustrating engagement of another modified embodiment of the retainer ring and a shank of the screwdriver.

FIG. 4B is a view similar to FIG. 4A, wherein the retainer ring is rotated 30° in a counterclockwise direction.

FIG. 4C is a view similar to FIG. 4A, wherein the retainer ring is rotated 60° in a counterclockwise direction.

FIG. 5A is a sectional view illustrating engagement of a further modified embodiment of the retainer ring and a shank of the screwdriver.

FIG. 5B is a view similar to FIG. 5A, wherein the retainer ring is rotated 30° in a counterclockwise direction.

FIG. 5C is a view similar to FIG. 5A, wherein the retainer ring is rotated 60° in a counterclockwise direction.

FIG. 6A is a sectional view illustrating engagement between a conventional retainer ring and a screwdriver shank.

FIG. 6B is a sectional view illustrating anomalous engagement between the retainer ring and the screwdriver shank in FIG. 6A.

FIG. 7 is a schematic sectional view illustrating difficulty of attaching a bit to the screwdriver shank when the retainer ring is anomalously engaged with the screwdriver shank.

DETAILED DESCRIPTION OF THE PREFERRED EMBODIMENTS

Referring to FIG. 1, in accordance with the present invention, a retainer ring **10** is provided to securely retain a first object, e.g., a bit **30** to a second object, e.g., a shank **22** of a screwdriver **20**. The screwdriver **20** includes a handle **21** attached to an end of the shank **22**. A generally hexagonal receiving compartment **24** is defined in the other end **23** of the shank. An annular groove **25** is defined in an inner periphery defining the receiving compartment **24**.

Referring to FIGS. 1 and 2A, the retainer ring **10** is a substantially C-shaped resilient ring having an opening **13** between the distal ends **11a** thereof. The retainer ring **10** includes at least two radially outward pressing sections **11** that press against a bottom wall defining the annular groove **25** of the shank **22** and at least one radially inward engaging section **12**. Namely, the engaging section **12** is located in a position radially inward of the pressing sections **11**. In this embodiment, the retainer ring **10** includes three pressing sections **11** located on the distal ends **11a** of the retainer ring **10** and a section **11b** of the retainer ring **10** opposite to the openings **13** of the retainer ring **10**. It is noted that the opening **13** of the retainer ring **10** is smaller than a half of a circumference of a circle on which the retainer ring **10** locates. Further, the retainer ring **10** includes two engaging sections **12** on both sides of the section **11b** opposite to the opening **13** of the retainer ring **10**.

As illustrated in FIG. 2A, when the retainer ring **10** is mounted into the annular groove **25** of the shank **22** of the screwdriver **20**, the retainer ring **10** is securely retained in the annular groove **25** of the shank **22**, as the pressing sections **11** press against the bottom wall defining the annular groove **25** of the shank **22**. Further, the engaging sections **12** are respectively exposed to the second corner and the fifth corner of the receiving compartment **24** of the shank **22** (see the intersections P).

Thus, when a bit **30** is inserted into the receiving compartment **24** of the shank **22**, the retainer ring **10** would not move

3

or wobble in the annular groove 25 of the shank 22, as the three pressing sections 11 of the retainer ring 10 press against the bottom wall defining the annular groove 25 of the shank 22. Further, each engaging section 12 has a portion P engaged in a retaining groove 31 in a hexagonal end of the bit 30. Thus, the bit 30 is securely engaged in the receiving compartment 24 of the screwdriver 20.

Referring to FIG. 2B, when the retainer ring 10 is engaged in the annular groove 25 in another position, e.g., the retainer ring 10 is rotated 30° in a counterclockwise direction, the retainer ring 10 is securely retained in the annular groove 25 of the shank 22, as the pressing sections 11 press against the bottom wall defining the annular groove 25 of the shank 22. Further, the engaging sections 12 are respectively exposed to the third corner and the fifth corner of the receiving compartment 24 of the shank 22 (see the intersections P).

Thus, when a bit 30 is inserted into the receiving compartment 24 of the shank 22, the retainer ring 10 would not move or wobble in the annular groove 25 of the shank 22, as the three pressing sections 11 of the retainer ring 10 press against the bottom wall defining the annular groove 25 of the shank 22. Further, each engaging section 12 has a portion P engaged in the retaining groove 31 of the bit 30. Thus, the bit 30 is securely engaged in the receiving compartment 24 of the screwdriver 20.

Referring to FIG. 2C, when the retaining ring 10 is engaged in the annular groove 25 in another position, e.g., the retainer ring 10 is further rotated through 30° along the counterclockwise direction, the retainer ring 10 is securely retained in the annular groove 25 of the shank 22, as the pressing sections 11 press against the bottom wall defining the annular groove 25 of the shank 22. Further, the engaging sections 12 are respectively exposed to the third corner and the sixth corner of the receiving compartment 24 of the shank 22 (see the intersections P).

Thus, when a bit 30 is inserted into the receiving compartment 24 of the shank 22, the retainer ring 10 would not move or wobble in the annular groove 25 of the shank 22, as the three pressing sections 11 of the retainer ring 10 press against the bottom wall defining the annular groove 25 of the shank 22. Further, each engaging section 12 has a portion P engaged in the retaining groove 31 of the bit 30. Thus, the bit 30 is securely engaged in the receiving compartment 24 of the screwdriver 20.

FIG. 3A illustrates a modified embodiment of the retainer ring 10, wherein like numerals denote like elements. In this embodiment, the retainer ring 10 includes two radially outward pressing sections 11 and a radially inward engaging section 12 between the pressing sections 11. One of the pressing sections 11 has a length approximately half of the retainer ring 10, while the other pressing section 11 is much shorter.

As illustrated in FIG. 3A, when the retainer ring 10 is mounted into the annular groove 25 of the shank 22 of the screwdriver 20, the retainer ring 10 is securely retained in the annular groove 25 of the shank 22, as the pressing sections 11 press against the bottom wall defining the annular groove 25 of the shank 22. Further, the engaging section 12 is exposed to the fourth corner of the receiving compartment 24 of the shank 22 (see the intersection P).

Thus, when a bit 30 is inserted into the receiving compartment 24 of the shank 22, the retainer ring 10 would not move or wobble in the annular groove 25 of the shank 22, as the pressing sections 11 of the retainer ring 10 press against the bottom wall defining the annular groove 25 of the shank 22. Further, the engaging section 12 has a portion P engaged in

4

the retaining groove 31 of the bit 30. Thus, the bit 30 is securely engaged in the receiving compartment 24 of the screwdriver 20.

Referring to FIG. 3B, when the retainer ring 10 is engaged in the annular groove 25 in another position, e.g., the retainer ring 10 is rotated 30° in a counterclockwise direction, the retainer ring 10 is securely retained in the annular groove 25 of the shank 22, as the pressing sections 11 press against the bottom wall defining the annular groove 25 of the shank 22. Further, the engaging section 12 is exposed to the fifth corner of the receiving compartment 24 of the shank 22 (see the intersection P).

Thus, when a bit 30 is inserted into the receiving compartment 24 of the shank 22, the retainer ring 10 would not move or wobble in the annular groove 25 of the shank 22, as the three pressing sections 11 of the retainer ring 10 press against the bottom wall defining the annular groove 25 of the shank 22. Further, the engaging section 12 has a portion P engaged in the retaining groove 31 of the bit 30. Thus, the bit 30 is securely engaged in the receiving compartment 24 of the screwdriver 20.

Referring to FIG. 3C, when the retainer ring 10 is engaged in the annular groove 25 in another position, e.g., the retainer ring 10 is further rotated 30° in a counterclockwise direction, the retainer ring 10 is securely retained in the annular groove 25 of the shank 22, as the pressing sections 11 press against the bottom wall defining the annular groove 25 of the shank 22. Further, the engaging section 12 is exposed to the fifth corner of the receiving compartment 24 of the shank 22 (see the intersection P).

Thus, when a bit 30 is inserted into the receiving compartment 24 of the shank 22, the retainer ring 10 would not move or wobble in the annular groove 25 of the shank 22, as the three pressing sections 11 of the retainer ring 10 press against the bottom wall defining the annular groove 25 of the shank 22. Further, the engaging section 12 has a portion P engaged in the retaining groove 31 of the bit 30. Thus, the bit 30 is securely engaged in the receiving compartment 24 of the screwdriver 20.

FIG. 4A illustrates another modified embodiment of the retainer ring 10, wherein like numerals denote like elements. In this embodiment, the retainer ring 10 includes a radially inward engaging section 12 opposite to the opening 13 of the retainer ring 10 and two radially outward pressing sections [ii] 11 on both sides of the engaging section 12. Each radially outward pressing sections 11 includes an associated one of the distal ends (not labeled) of the retainer ring 10.

As illustrated in FIG. 4A, when the retainer ring 10 is mounted into the annular groove 25 of the shank 22 of the screwdriver 20, the retainer ring 10 is securely retained in the annular groove 25 of the shank 22, as the pressing sections 11 press against the bottom wall defining the annular grooves 25 of the shank 22. Further, the engaging section 12 is exposed to the third corner and the fourth corner of the receiving compartment 24 of the shank 22 (see the intersections P).

Thus, when a bit 30 is inserted into the receiving compartment 24 of the shank 22, the retainer ring 10 would not move or wobble in the annular groove 25 of the shank 22, as the pressing sections 11 of the retainer ring 10 press against the bottom wall defining the annular groove 25 of the shank 22. Further, the engaging section 12 has two portions P engaged in the retaining groove 31 of the bit 30. Thus, the bit 30 is securely engaged in the receiving compartment 24 of the screwdriver 20.

Referring to FIG. 4B when the retainer ring 10 is engaged in the annular groove 25 in another position, e.g., the retainer

5

ring 10 is rotated 30° in a counterclockwise direction, the retainer ring 10 is securely retained in the annular groove 25 of the shank 22, as the pressing sections 11 press against the bottom wall defining the annular groove 25 of the shank 22. Further, the engaging section 12 is exposed to the fourth corner of the receiving compartment 24 of the shank 22 (see the intersection P).

Thus, when a bit 30 is inserted into the receiving compartment 24 of the shank 22, the retainer ring 10 would not move or wobble in the annular groove 25 of the shank 22, as the pressing section 11 of the retainer ring 10 press against the bottom wall defining the annular groove 25 of the shank 22. Further, the engaging section 12 is engaged in the retaining groove 31 of the bit 30. Thus, the bit 30 is securely engaged in the receiving compartment 24 of the screwdriver 20.

Referring to FIG. 4C, when the retainer ring 10 is engaged in the annular groove 25 in another position, e.g., the retainer ring 10 is further rotated 30° in a counterclockwise direction, the retainer ring 10 is securely retained in the annular groove 25 of the shank 22, as the pressing sections 11 press against the bottom wall defining the annular groove 25 of the shank 22. Further, the engaging section 12 is exposed to the fourth corner and the fifth corner of the receiving compartment 24 of the shank 22 (see the intersection P).

Thus, when a bit 30 is inserted into the receiving compartment 24 of the shank 22, the retainer ring 10 would not move or wobble in the annular groove 25 of the shank 22, as the pressing sections 11 of the retainer ring 10 press against the bottom wall defining the annular groove 25 of the shank 22. Further, the engaging section 12 has two portions P engaged in the retaining groove 31 of the bit 30. Thus, the bit 30 is securely engaged in the receiving compartment 24 of the screwdriver 20.

FIG. 5A illustrates a further modified embodiment of the retainer ring 10, wherein like numerals denotes like elements. In this embodiment, the retainer ring 10 includes four radially outward pressing sections 11 and three radially inward engaging sections 12, wherein each engaging section 12 is located between two pressing sections 11.

As illustrated in FIG. 5A, when the retainer ring 10 is mounted into the annular groove 25 of the shank 22 of the screwdriver 20, the retainer ring 10 is securely retained in the annular groove 25 of the shank 22, as the pressing sections 11 press against the bottom wall defining the annular groove 25 of the shank 22. Further, the engaging sections 12 are exposed to the second corner, the third corner, the fourth corner, and the fifth corner of the receiving compartment 24 of the shank 22 (see the intersections P).

Thus, when a bit 30 is inserted into the receiving compartment 24 of the shank 22, the retainer ring 10 would not move or wobble in the annular groove 25 of the shank 22, as the pressing sections 11 of the retainer ring 10 press against the bottom wall defining the annular groove 25 of the shank 22. Further, the engaging sections 12 have portions P engaged in the retaining groove 31 of the bit 30. Thus, the bit 30 is securely engaged in the receiving compartment 24 of the screwdriver 20.

Referring to FIG. 5B, when the retainer ring 10 is engaged in the annular groove 25 in another position, e.g., the retainer ring 10 is rotated 30° in a counterclockwise direction, the retainer ring 10 is securely retained in the annular groove 25 of the shank 22, as the pressing sections 11 press against the bottom wall defining the annular groove 25 of the shank 22. Further, the middle engaging section 12 is exposed to the fourth corner of the receiving compartment 24 of the shank 22 (see the intersection P).

6

Thus, when a bit 30 is inserted into the receiving compartment 24 of the shank 22, the retainer ring 10 would not move or wobble in the annular groove 25 of the shank 22, as the pressing sections 11 of the retainer ring 10 press against the bottom wall defining the annular groove 25 of the shank 22. Further, the middle engaging section 12 has a portion P engaged in the retaining groove 31 of the bit 30. Thus, the bit 30 is securely engaged in the receiving compartment 24 of the screwdriver 20.

Referring to FIG. 5C, when the retainer ring 10 is engaged in the annular groove 25 in another position, e.g., the retainer ring 10 is further rotated 30° in a counterclockwise direction, the retainer ring 10 is securely retained in the annular groove 25 of the shank 22, as the pressing sections 11 press against the bottom wall defining the annular groove 25 of the shank 22. Further, the engaging sections 12 are exposed to the third corner, the fourth corner, the fifth corner, and the sixth corner of the receiving compartment 24 of the shank 22 (see the intersections P).

Thus, when a bit 30 is inserted into the receiving compartment 24 of the shank 22, the retainer ring 10 would not move or wobble in the annular groove 25 of the shank 22, as the pressing sections 11 of the retainer ring 10 press against the bottom wall defining the annular groove 25 of the shank 22. Further, the engaging sections 12 have portions P engaged in the retaining groove 31 of the bit 30. Thus, the bit 30 is securely engaged in the receiving compartment 24 of the screwdriver 20.

According to the above description, it is noted that the engaging section(s) 12 of the retainer ring 10 includes at least one portion that is securely engaged in the retaining groove 31 of the bit 30 regardless of the angular position of the retainer ring 10 in the annular groove 25 of the shank 22 of the screwdriver 20.

It is noted that the numbers and the shapes of the pressing sections 11 and the engaging sections 12 may vary according to the need.

Although the invention has been explained in relation to its preferred embodiment, it is to be understood that many other possible modifications and variations can be made without departing from the scope of the invention as hereinafter claimed.

What is claimed is:

1. A combination comprising:

- a first object including a retaining groove in an end thereof;
- a second object including a receiving compartment for removably receiving said end of said first object, said receiving compartment having a plurality of corners, an annular groove being defined in an inner periphery defining said receiving compartment; and
- a resilient retainer ring received in the annular groove, said retainer ring including at least two pressing sections and at least one engaging section, with said at least two pressing sections separated by said at least one engaging section, wherein both of said at least two pressing sections simultaneously press against a bottom wall defining said annular groove of said second object and are located outside of the retaining groove, with said at least two pressing sections holding said at least one engaging section away from the bottom wall defining said annular groove, wherein said at least one engaging section is exposed to at least one of said corners of said receiving compartment by being held by said at least two pressing sections simultaneously pressing against the annular groove such that said at

7

least one engaging section has at least a portion engaged in said retaining groove when said end of said first object is received in said receiving compartment.

2. The combination as claimed in claim 1, wherein said retainer ring includes two distal ends spaced by an opening, each of said distal ends of said retainer forming an associated one of said at least two pressing sections.

3. The combination as claimed in claim 2, wherein one of said at least two pressing sections is opposite to said opening.

4. The combination as claimed in claim 3, wherein said first object is a bit and said second object is a shank of a screwdriver.

5. The combination as claimed in claim 4, wherein said receiving compartment is hexagonal and said end of said first object is hexagonal.

6. The combination as claimed in claim 3, wherein said receiving compartment is hexagonal and said end of said first object is hexagonal.

7. The combination as claimed in claim 2, wherein said first object is a bit and said second object is a shank of a screwdriver.

8. The combination as claimed in claim 7, wherein said receiving compartment is hexagonal and said end of said first object is hexagonal.

9. The combination as claimed in claim 2, wherein said receiving compartment is hexagonal and said end of said first object is hexagonal.

10. The combination as claimed in claim 1, wherein said retainer ring includes an opening and wherein one of said at least one engaging section of said retainer ring is opposite to said opening.

11. The combination as claimed in claim 10, wherein said first object is a bit and said second object is a shank of a screwdriver.

12. The combination as claimed in claim 11, wherein said receiving compartment is hexagonal and said end of said first object is hexagonal.

13. The combination as claimed in claim 10, wherein said receiving compartment is hexagonal and said end of said first object is hexagonal.

14. The combination as claimed in claim 1, wherein one of said at least two pressing sections is longer than another of said at least two pressing sections.

15. The combination as claimed in claim 14, wherein said first object is a bit and said second object is a shank of a screwdriver.

16. The combination as claimed in claim 14, wherein said receiving compartment is hexagonal and said end of said first object is hexagonal.

17. The combination as claimed in claim 1, wherein said retainer ring includes a plurality of alternately disposed pressing sections and engaging sections.

18. The combination as claimed in claim 1, wherein said first object is a bit and said second object is a shank of a screwdriver.

8

19. The combination as claimed in claim 1, wherein said receiving compartment is hexagonal and said end of said first object is hexagonal.

20. The combination as claimed in claim 19, wherein said first object is a bit and said second object is a shank of a screwdriver.

21. A combination comprising:

an object including a receiving compartment adapted for removably receiving another object, said receiving compartment having a plurality of corners, an annular groove being defined in an inner periphery defining said receiving compartment; and

a resilient retainer ring received in the annular groove, said retainer ring including at least two pressing sections and at least one engaging section, with said at least two pressing sections separated by said at least one engaging section, wherein both of said at least two pressing sections simultaneously press against a bottom wall defining said annular groove of said object, with said at least two pressing sections holding said at least one engaging section away from the bottom wall defining said annular groove, wherein said at least one engaging section is exposed to at least one of said corners of said receiving compartment by being held by said at least two pressing sections simultaneously pressing against the bottom wall defining said annular groove such that said at least one engaging section has at least a portion engaged with said another object when said another object is received in said receiving compartment.

22. The combination as claimed in claim 21, wherein said retainer ring includes two distal ends spaced by an opening, each of said distal ends of said retainer forming an associated one of said at least two pressing sections.

23. The combination as claimed in claim 22, wherein one of said at least two pressing sections is opposite to said opening.

24. The combination as claimed in claim 21, wherein said retainer ring includes an opening and wherein one of said at least one engaging section of said retainer ring is opposite to said opening.

25. The combination as claimed in claim 21, wherein one of said at least two pressing sections is longer than another of said at least two pressing sections.

26. The combination as claimed in claim 21, wherein said retainer ring includes a plurality of alternately disposed pressing sections and engaging sections.

27. The combination as claimed in claim 21, wherein said another object is a bit and said object is a shank of a screwdriver.

28. The combination as claimed in claim 21, wherein said receiving compartment is hexagonal and said another object is hexagonal.

* * * * *