



US00RE41239E

(19) **United States**
(12) **Reissued Patent**
Wood et al.

(10) **Patent Number:** **US RE41,239 E**
(45) **Date of Reissued Patent:** **Apr. 20, 2010**

(54) **METHOD AND APPARATUS FOR STRETCHING AN OPTICAL PULSE**
(76) Inventors: **James R. Wood**, 4145 Windomere Dr., Grapevine, TX (US) 76051; **Pradip Mitra**, 2805 Red Oak Ct., Colleyville, TX (US) 76034

3,923,380 A	12/1975	Hattori et al.
4,553,816 A	11/1985	Durand et al.
4,558,950 A	12/1985	Ulrich et al.
4,756,606 A	7/1988	Jewell et al.
4,990,465 A	2/1991	Liau et al.
5,343,489 A	8/1994	Wangler
5,452,121 A	9/1995	Hilgeman
5,584,117 A	12/1996	Lee et al.
5,759,453 A	6/1998	Kato
5,835,214 A	11/1998	Cabib et al.

(21) Appl. No.: **11/503,543**
(22) Filed: **Aug. 10, 2006**
(Under 37 CFR 1.47)

Related U.S. Patent Documents

Reissue of:

(64) Patent No.: **6,775,067**
Issued: **Aug. 10, 2004**
Appl. No.: **10/164,483**
Filed: **Jun. 6, 2002**

(51) **Int. Cl.**
G02B 1/10 (2006.01)

(52) **U.S. Cl.** **359/584**; 359/260; 359/579;
359/577; 356/519; 398/102

(58) **Field of Classification Search** 359/260,
359/577-579, 584; 356/519; 398/102
See application file for complete search history.

(56) **References Cited**
U.S. PATENT DOCUMENTS

3,879,109 A 4/1975 Thomas

Primary Examiner—Joshua L Pritchett

(57) **ABSTRACT**

A method and apparatus for stretching a pulse, shaping a stretched pulse, and modeling a stretched and/or shaped pulse are disclosed. An etalon has a port, a partially reflective surface, and a fully reflective surface. A base pulse is introduced into the etalon, and a plurality of portions of the base pulse propagating from the etalon are collected. The collected portions are then combined to generate a stretched pulse whose width is proportional to the width of the base pulse. This can be modeled by assigning a transmission factor value to each one of a plurality of tags and a reflection factor value to each one of the taps, excepting only one tap. A transport delay for is assigned to each tap to which a reflection factor value was assigned, wherein the transport delay is proportional to the width of a base pulse.

76 Claims, 9 Drawing Sheets

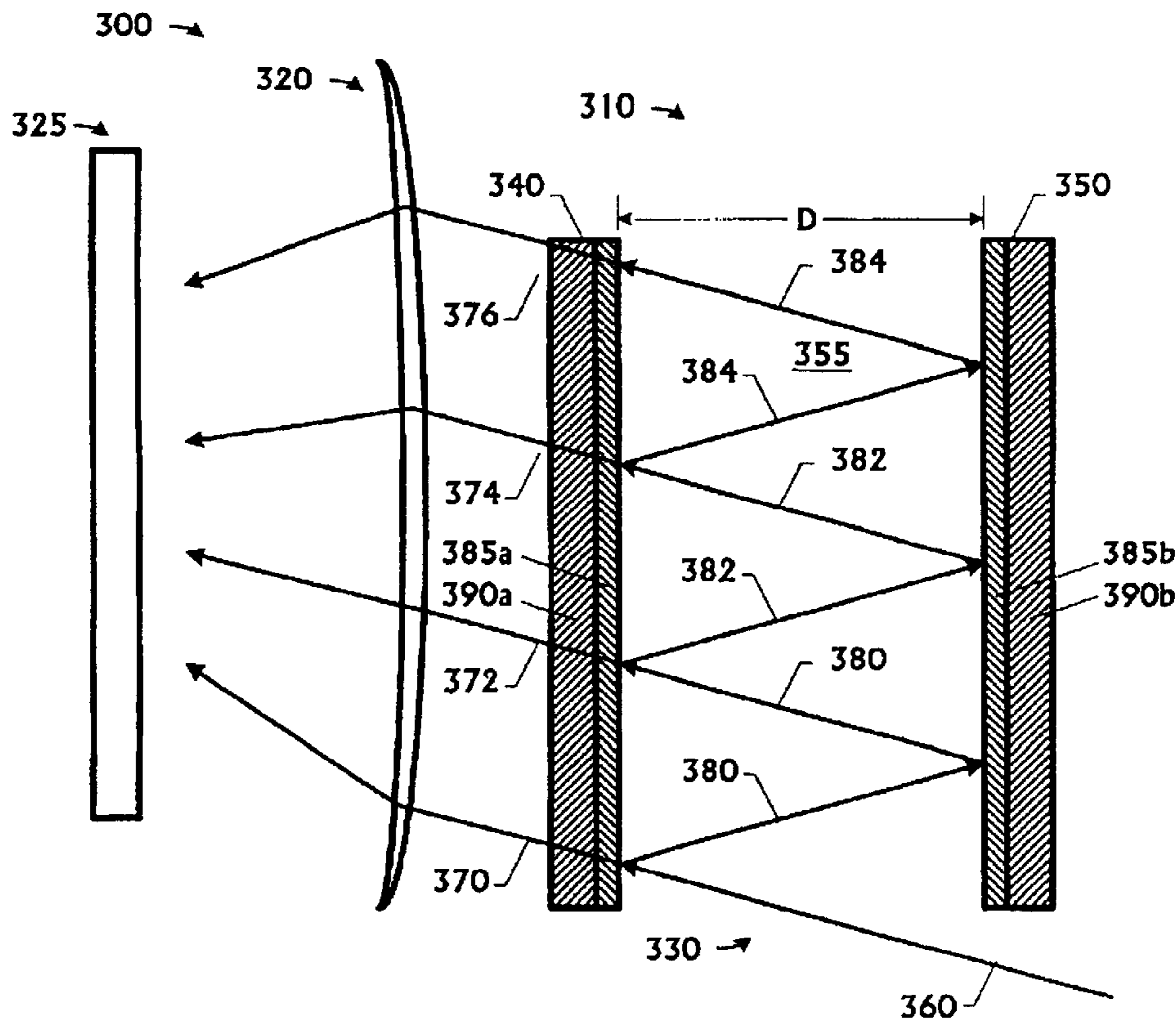

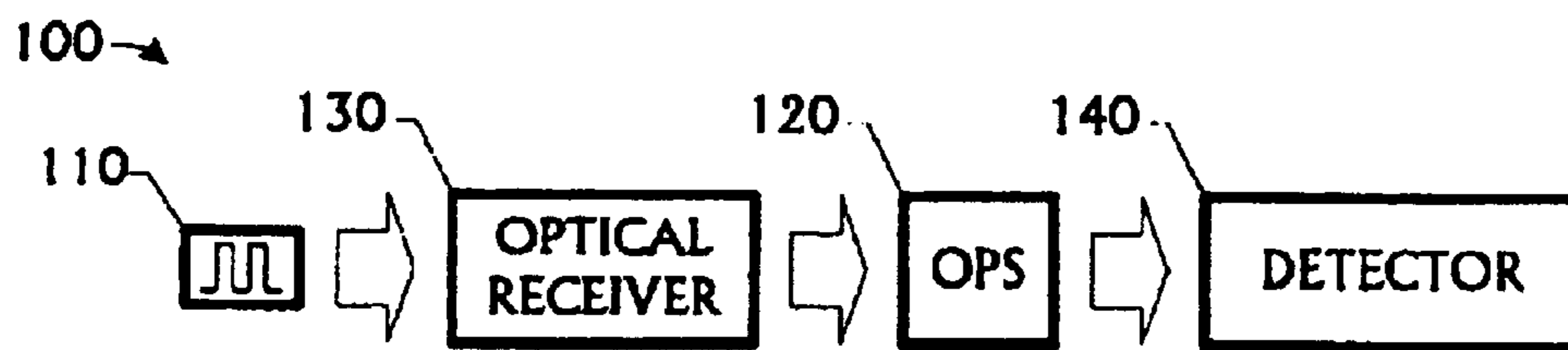

FIG. 1

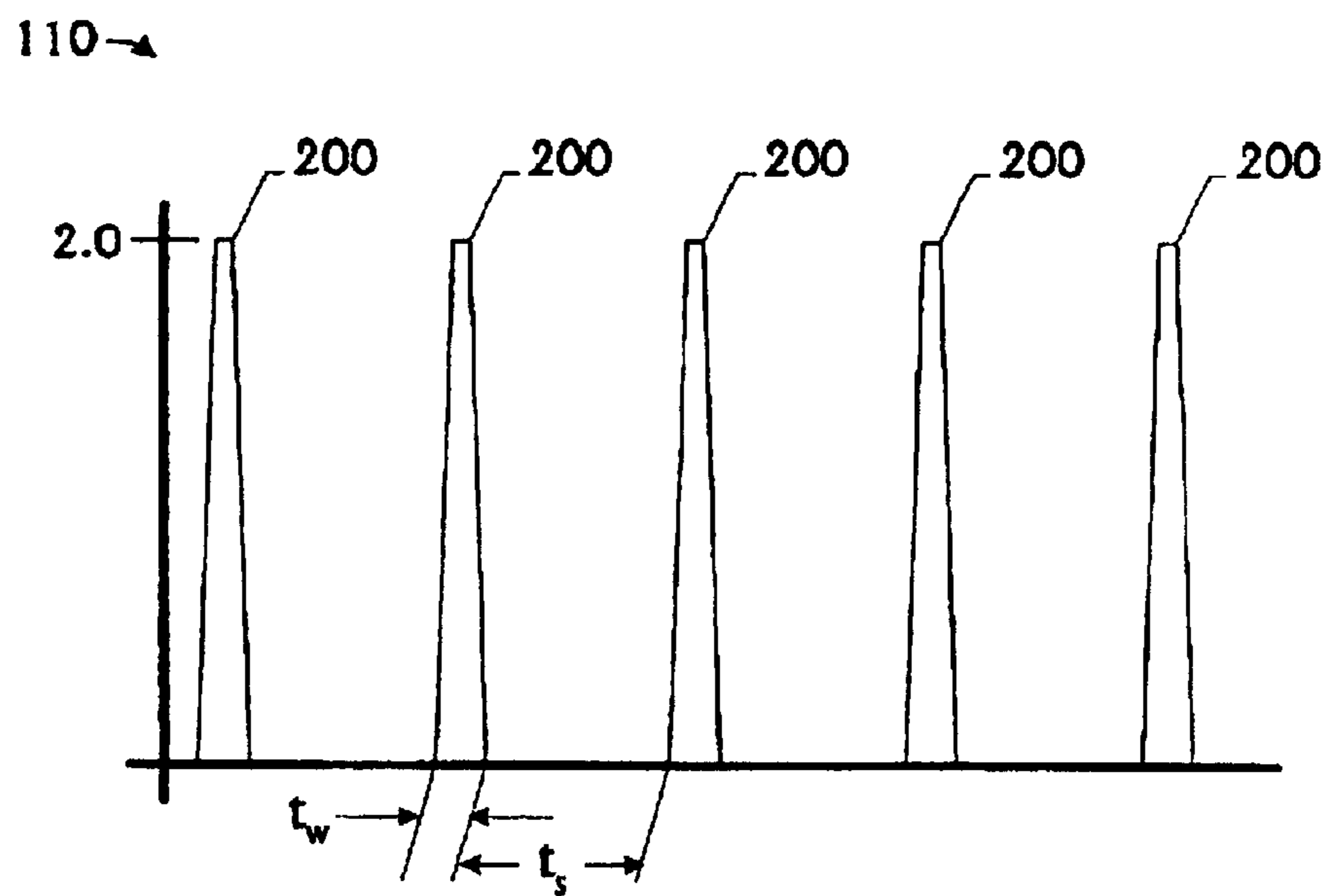

FIG. 2

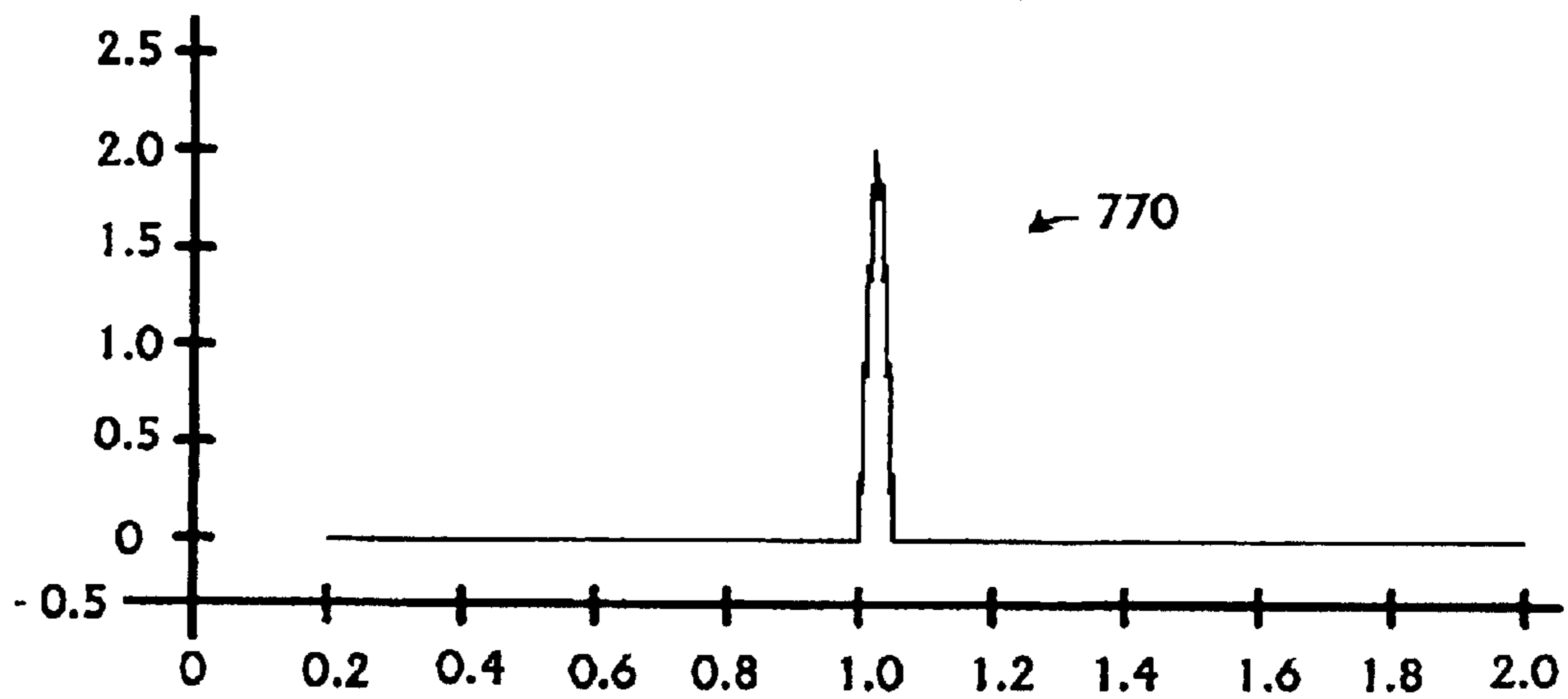

FIG. 7B

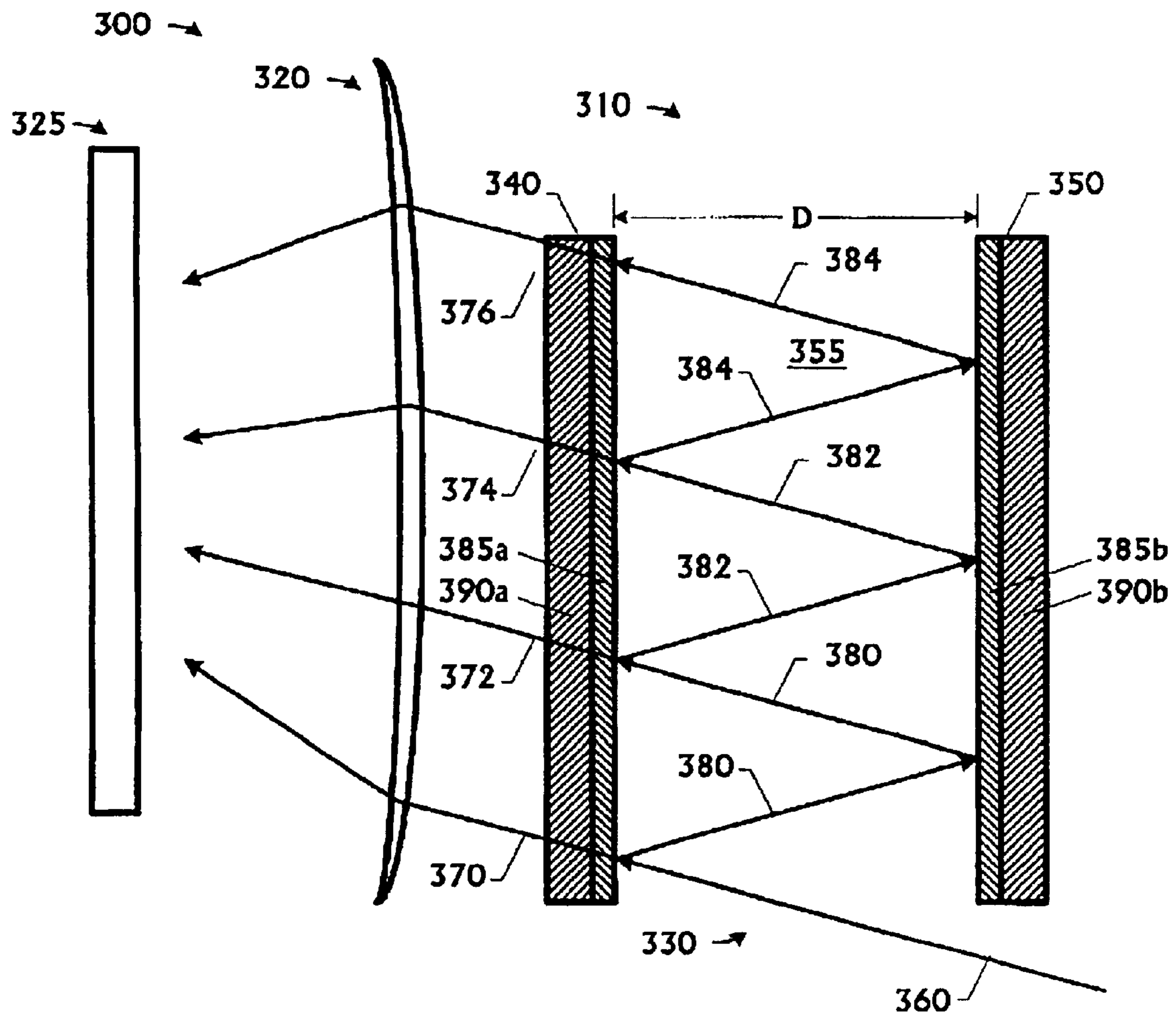

FIG. 3A

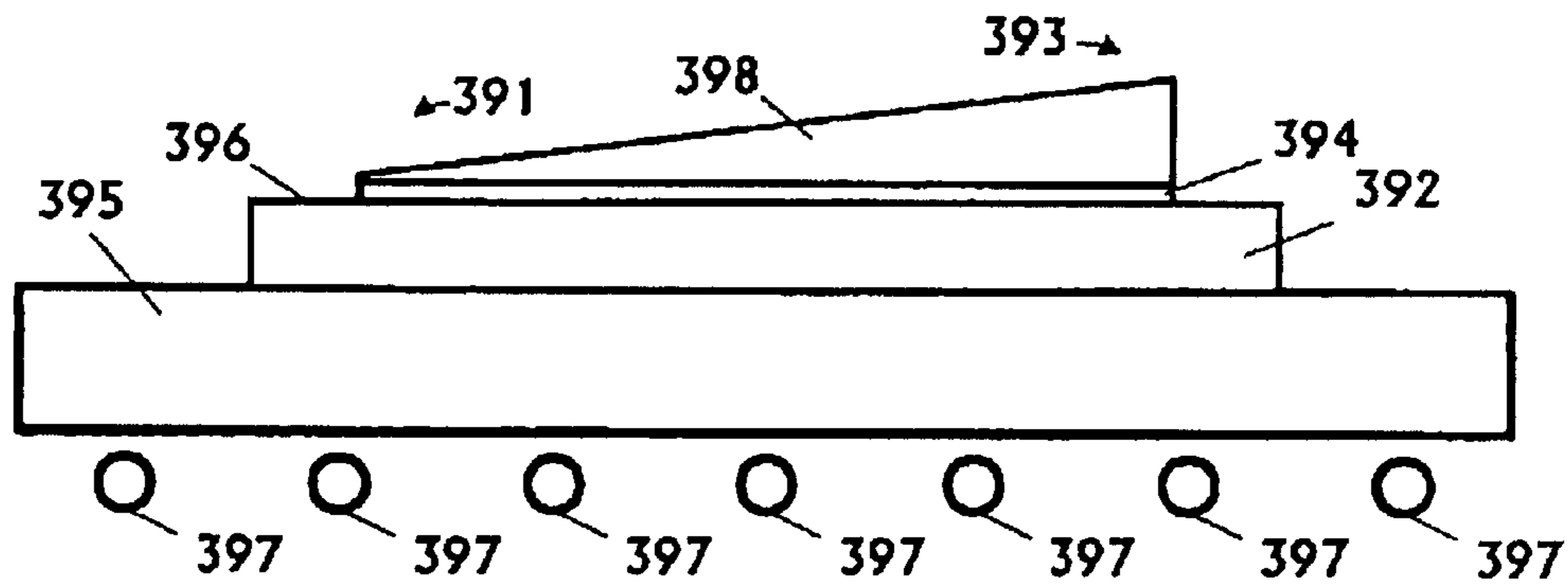

FIG. 3B

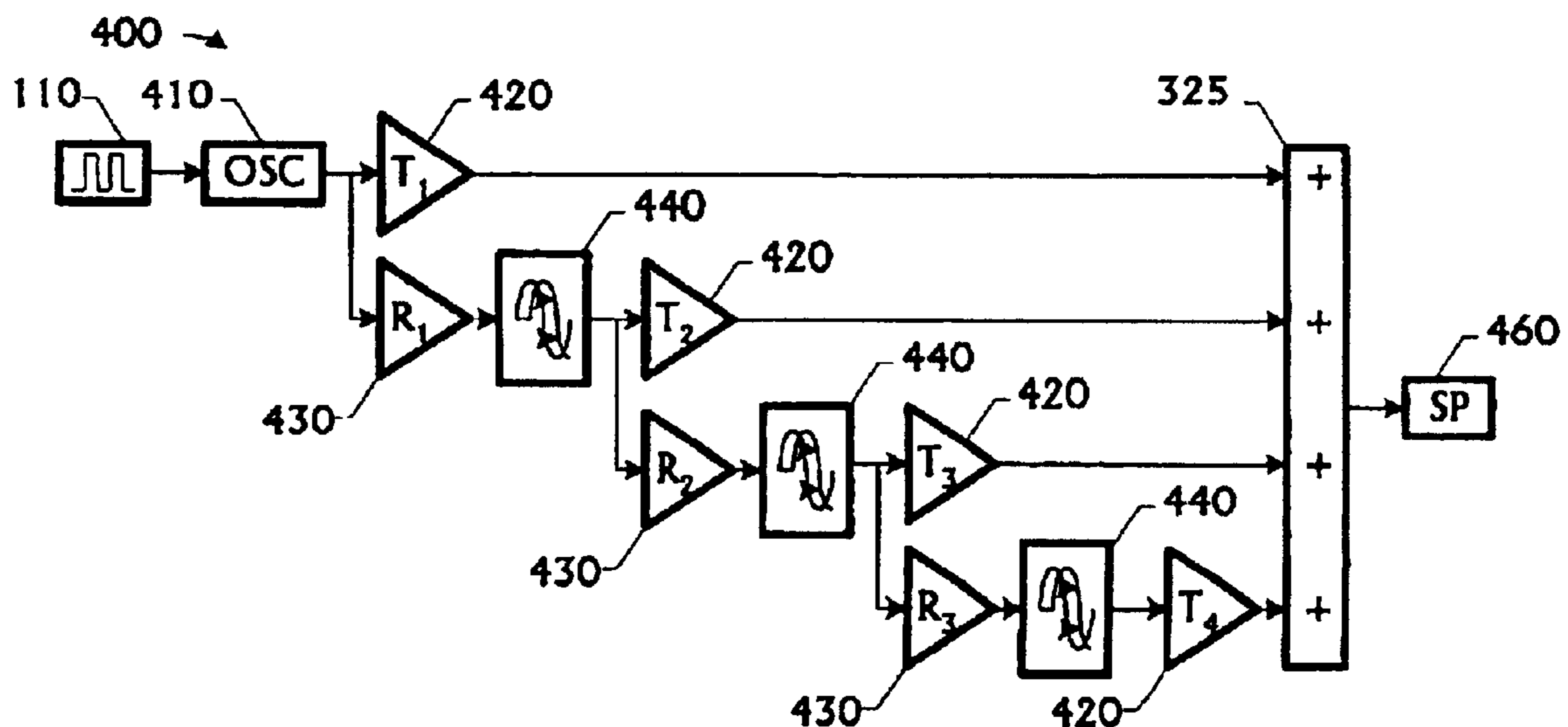

FIG. 4

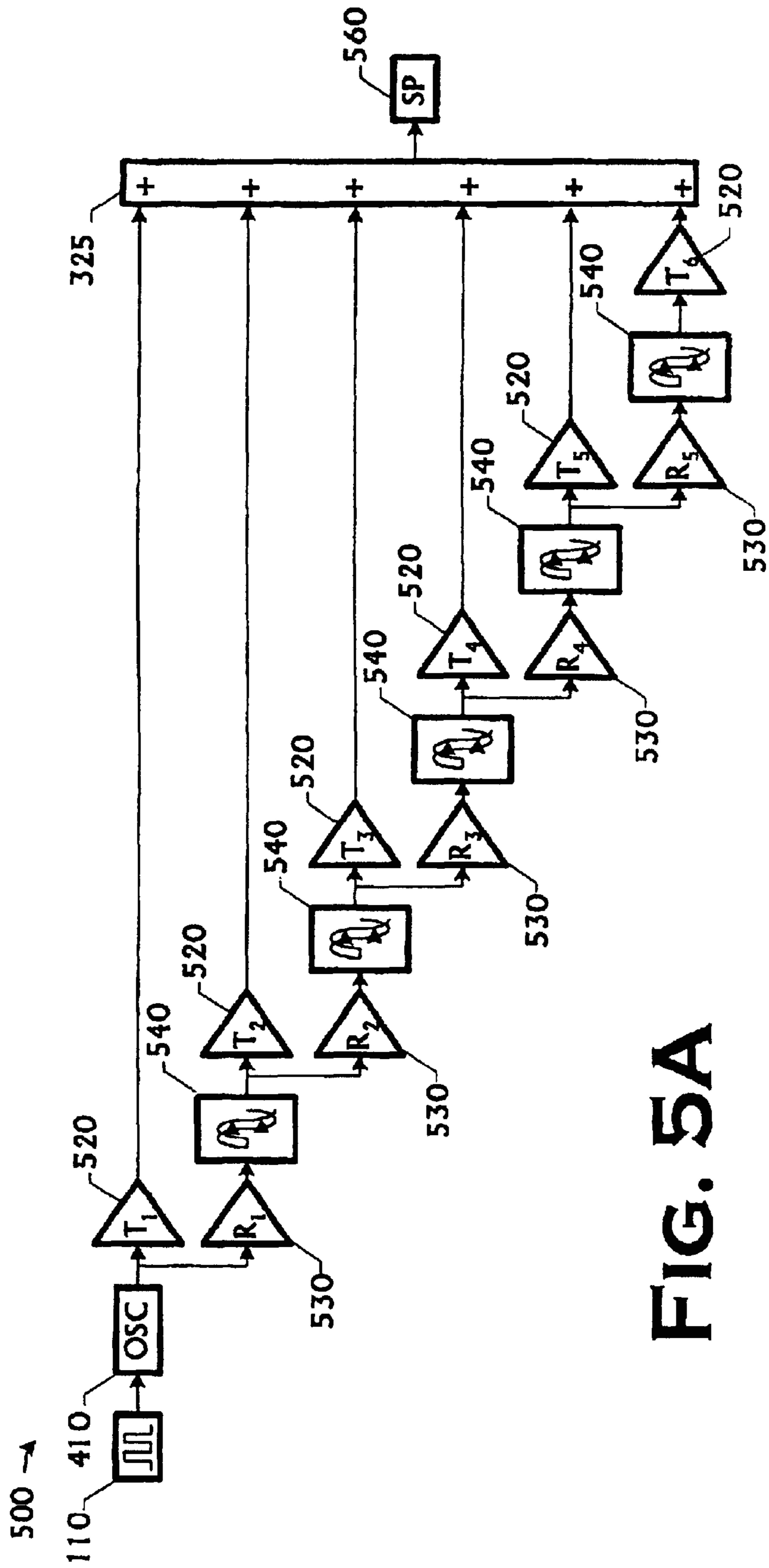

FIG. 5A

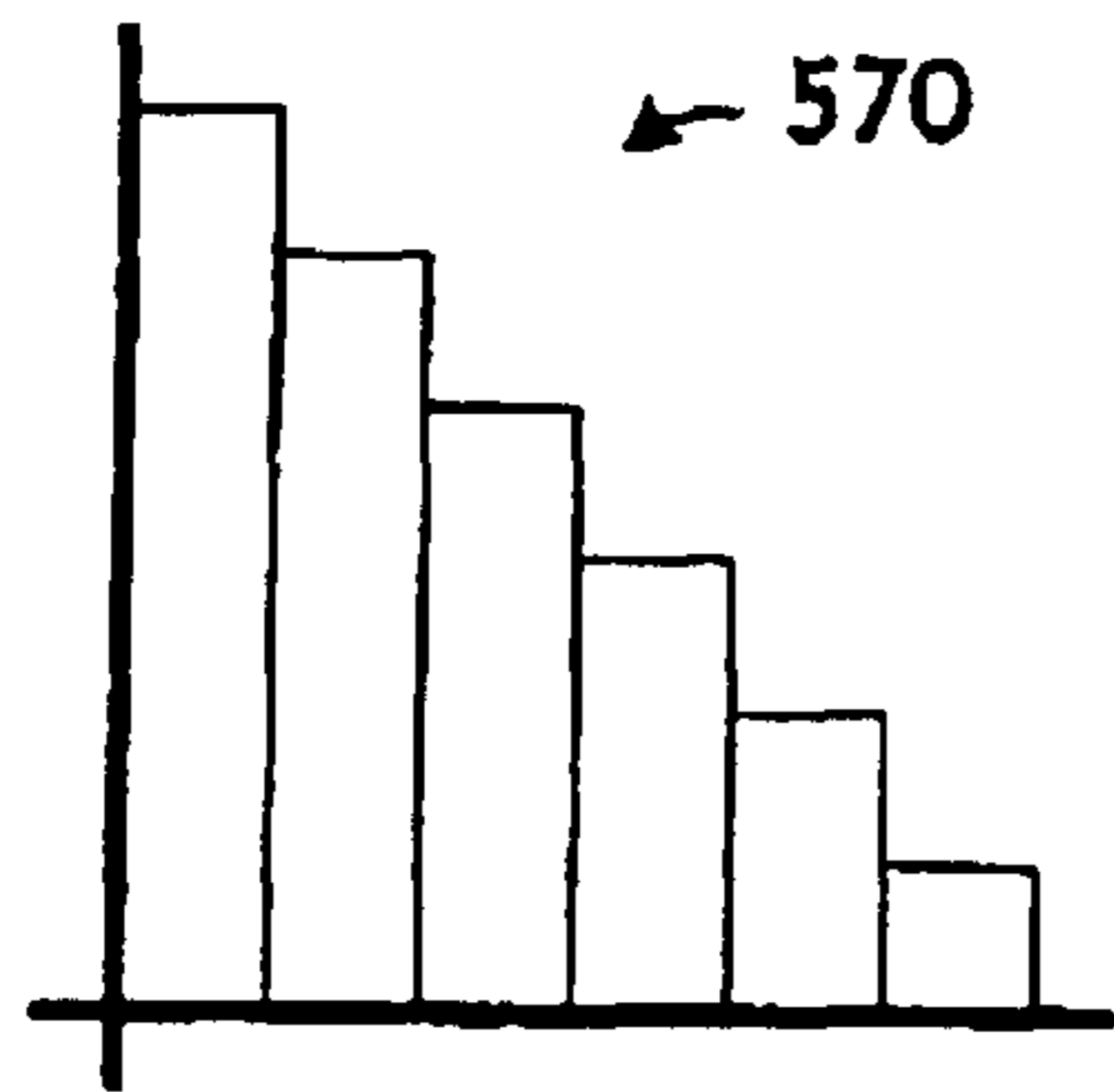

FIG. 5B

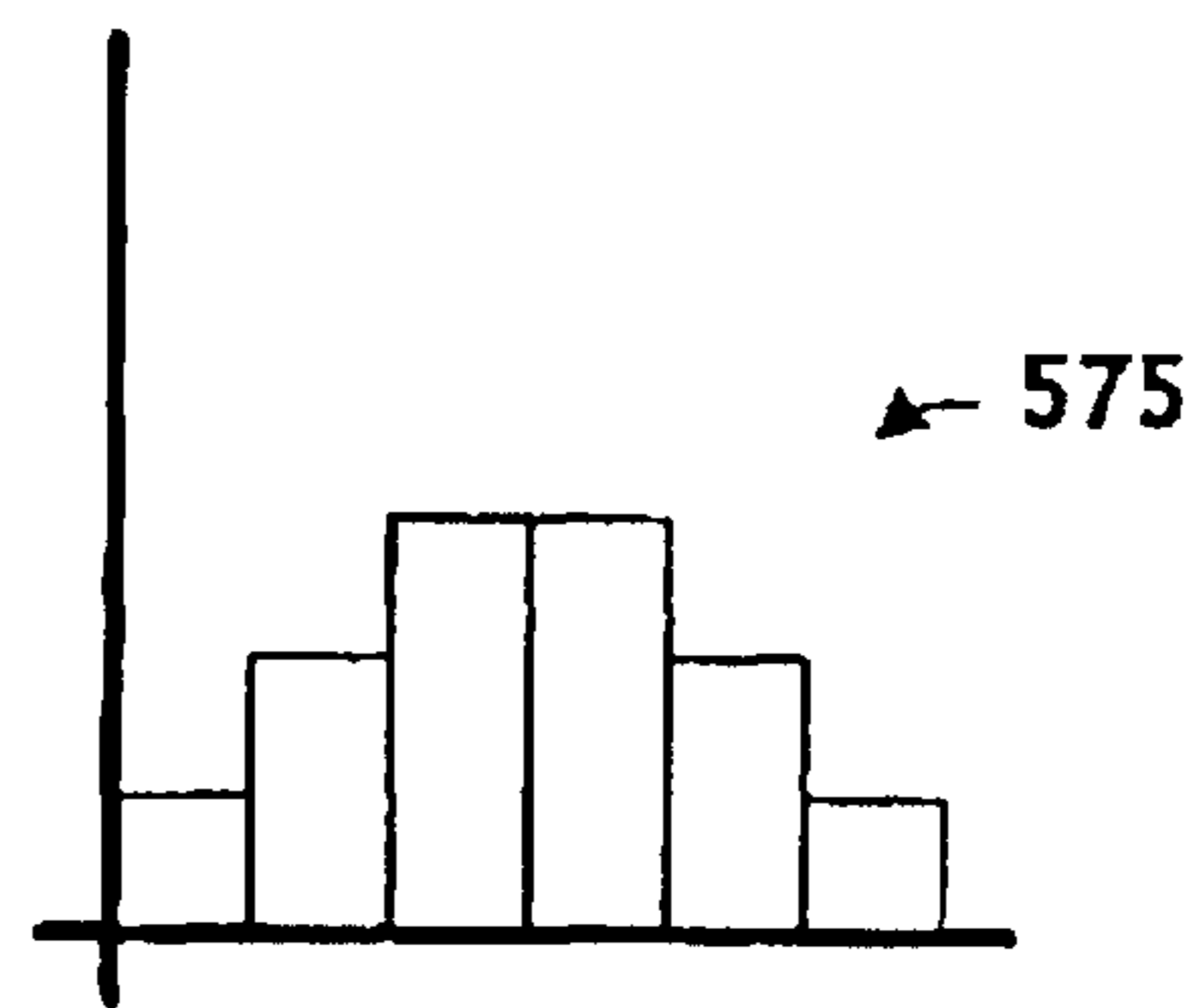

FIG. 5C

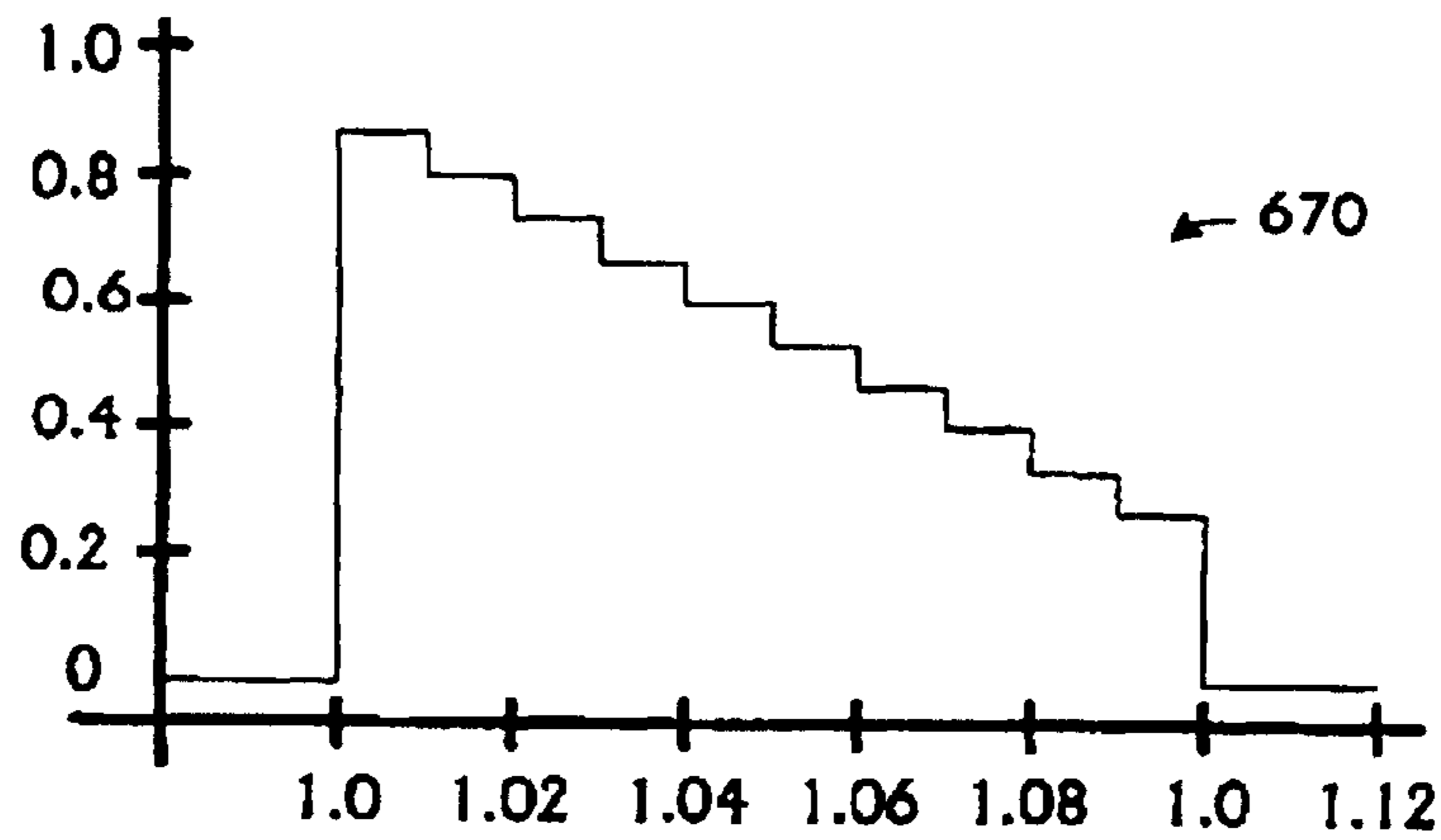

FIG. 6B

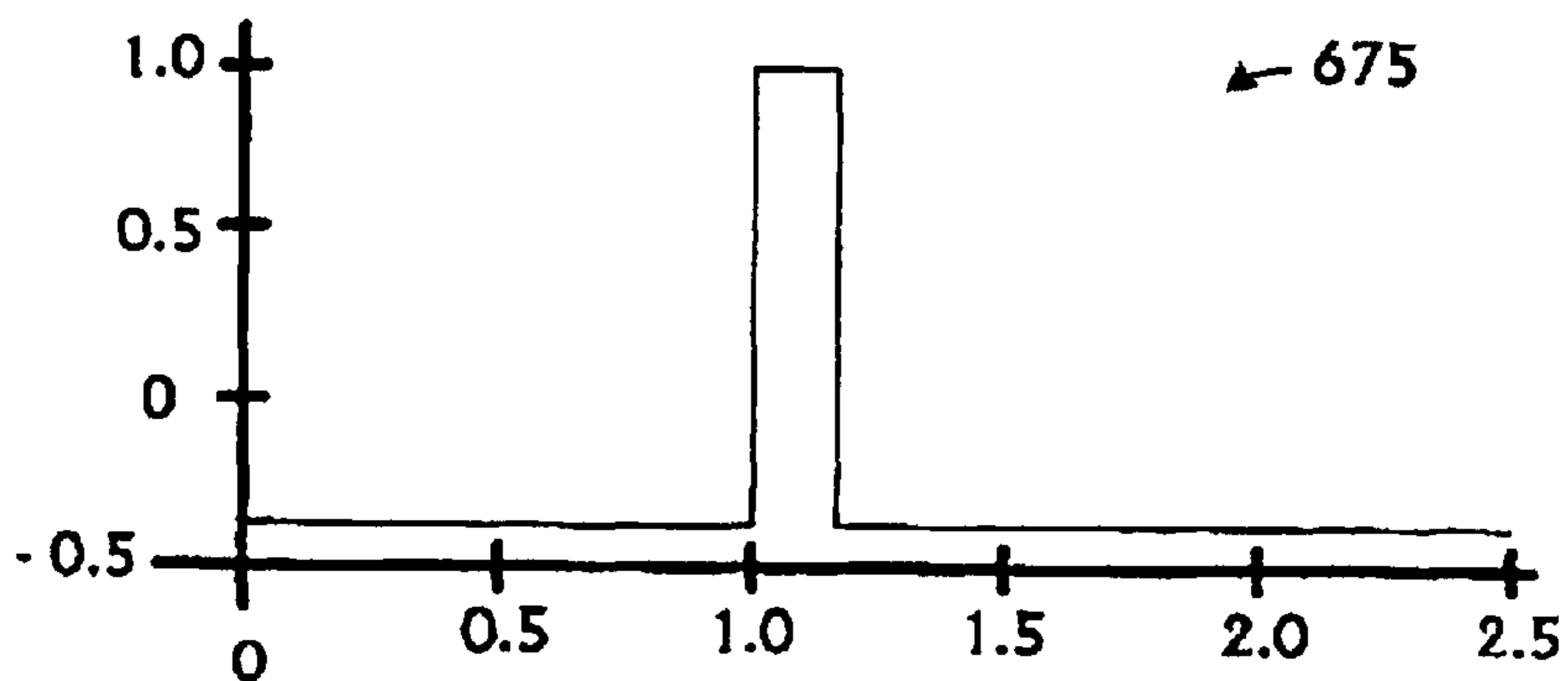

FIG. 6C

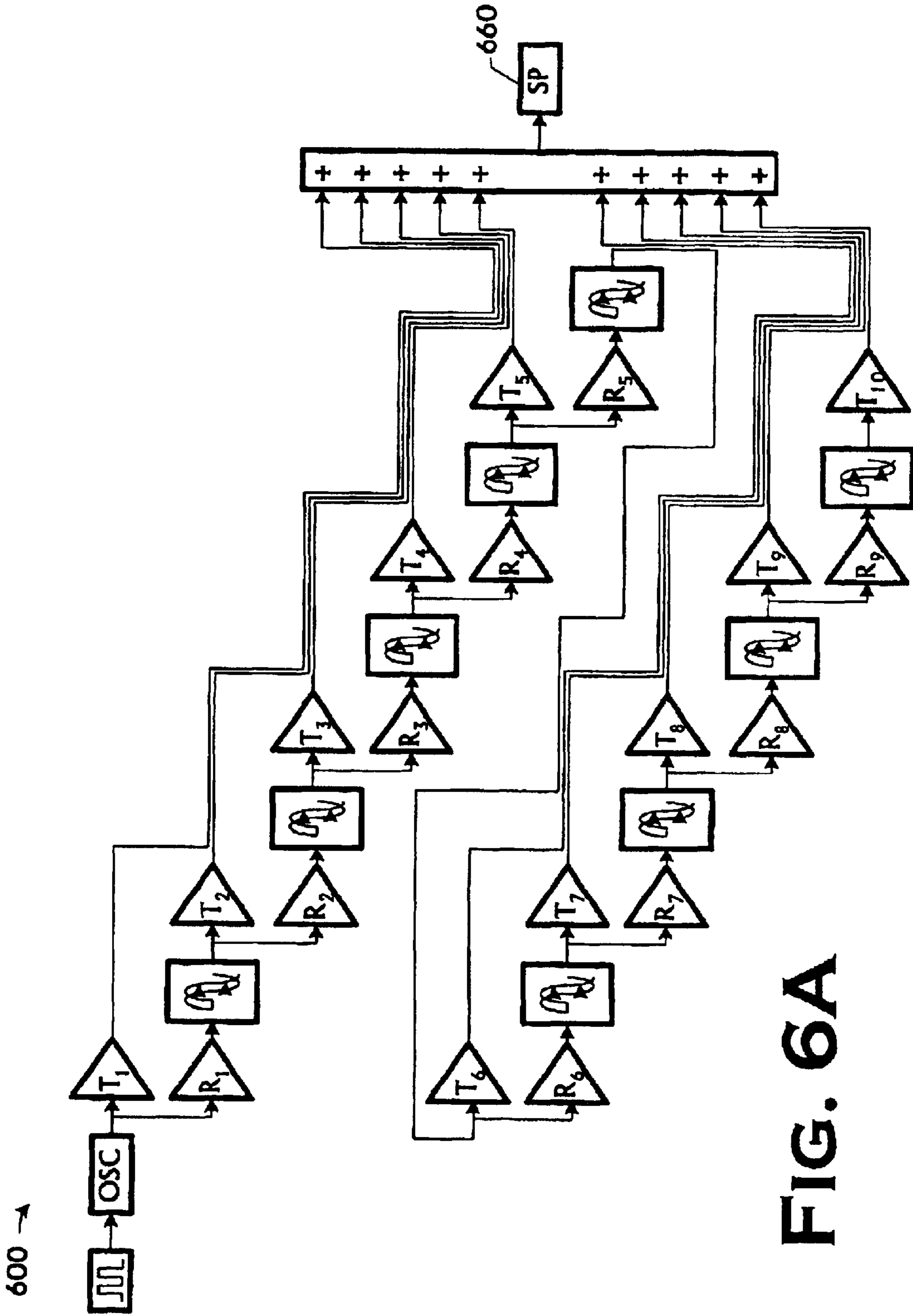

FIG. 6A

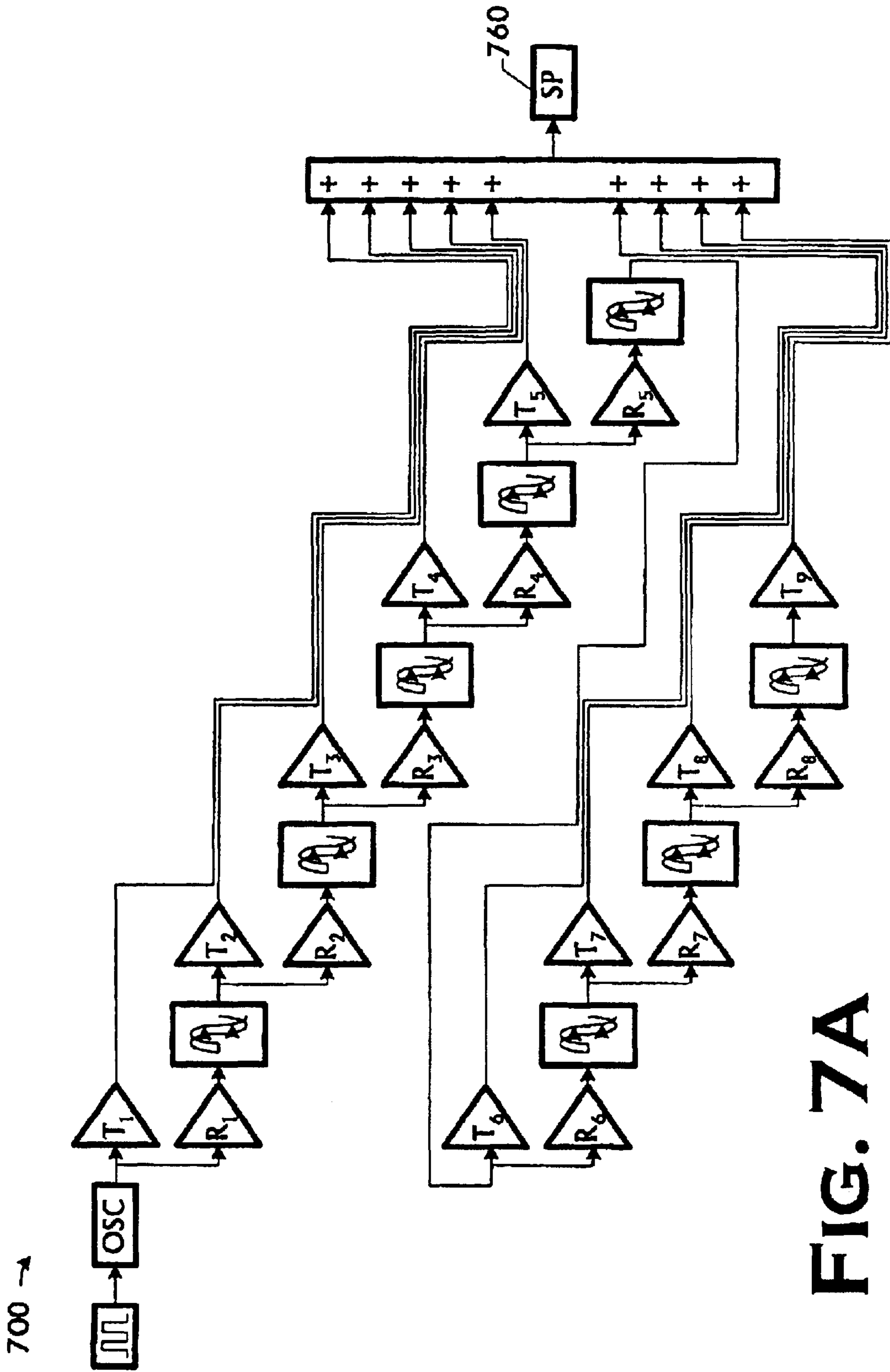

FIG. 7A

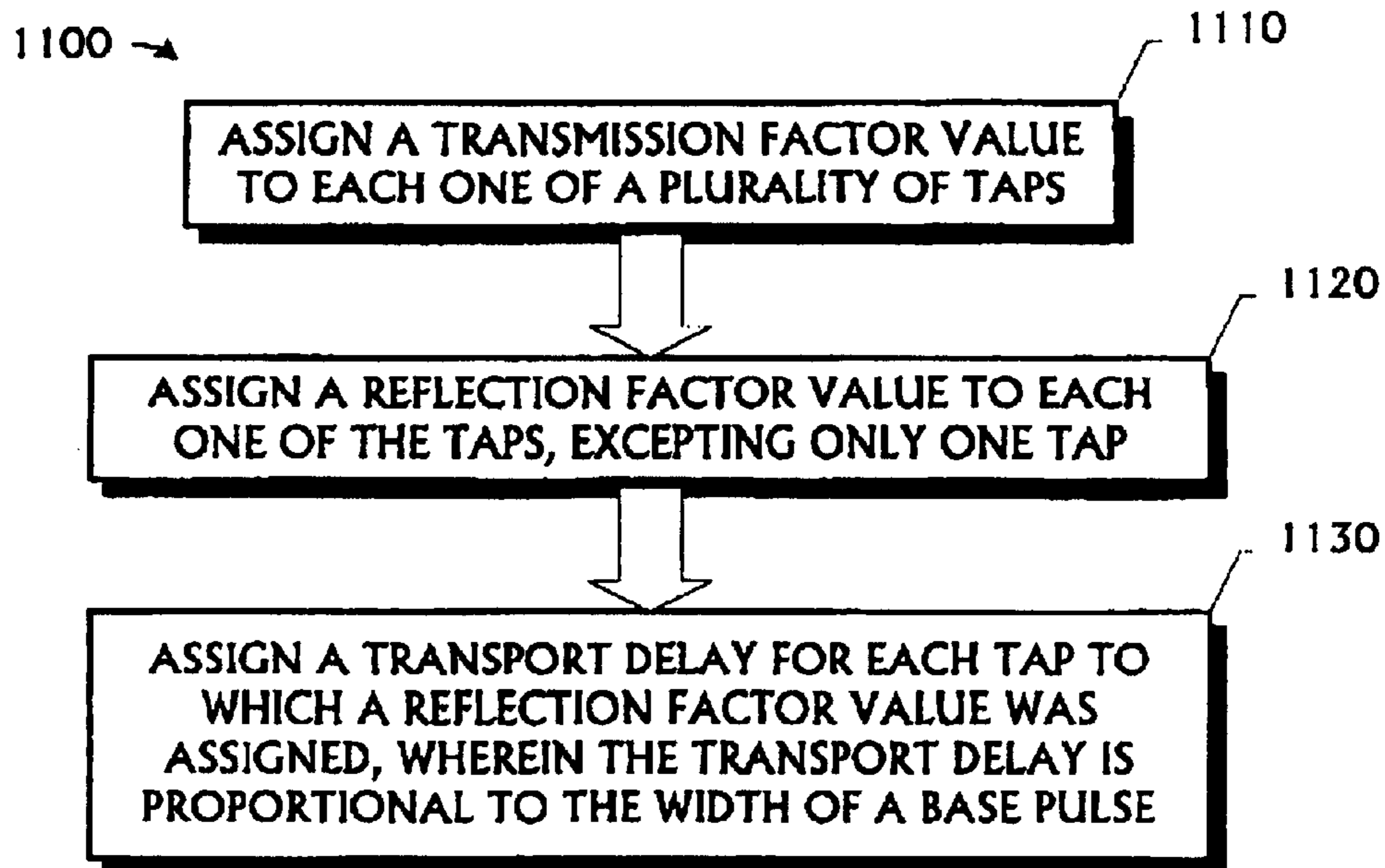

FIG. 11

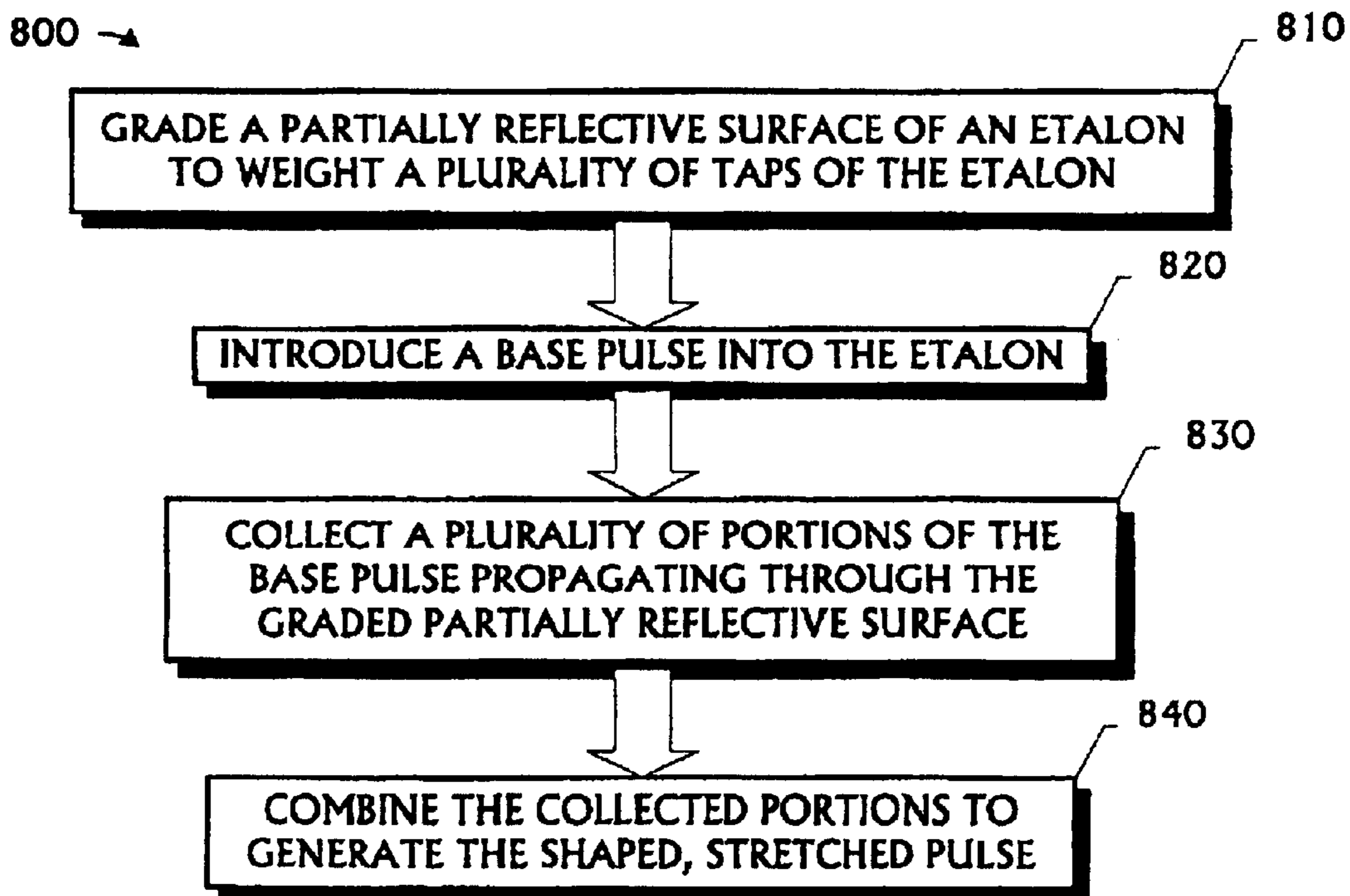

FIG. 8

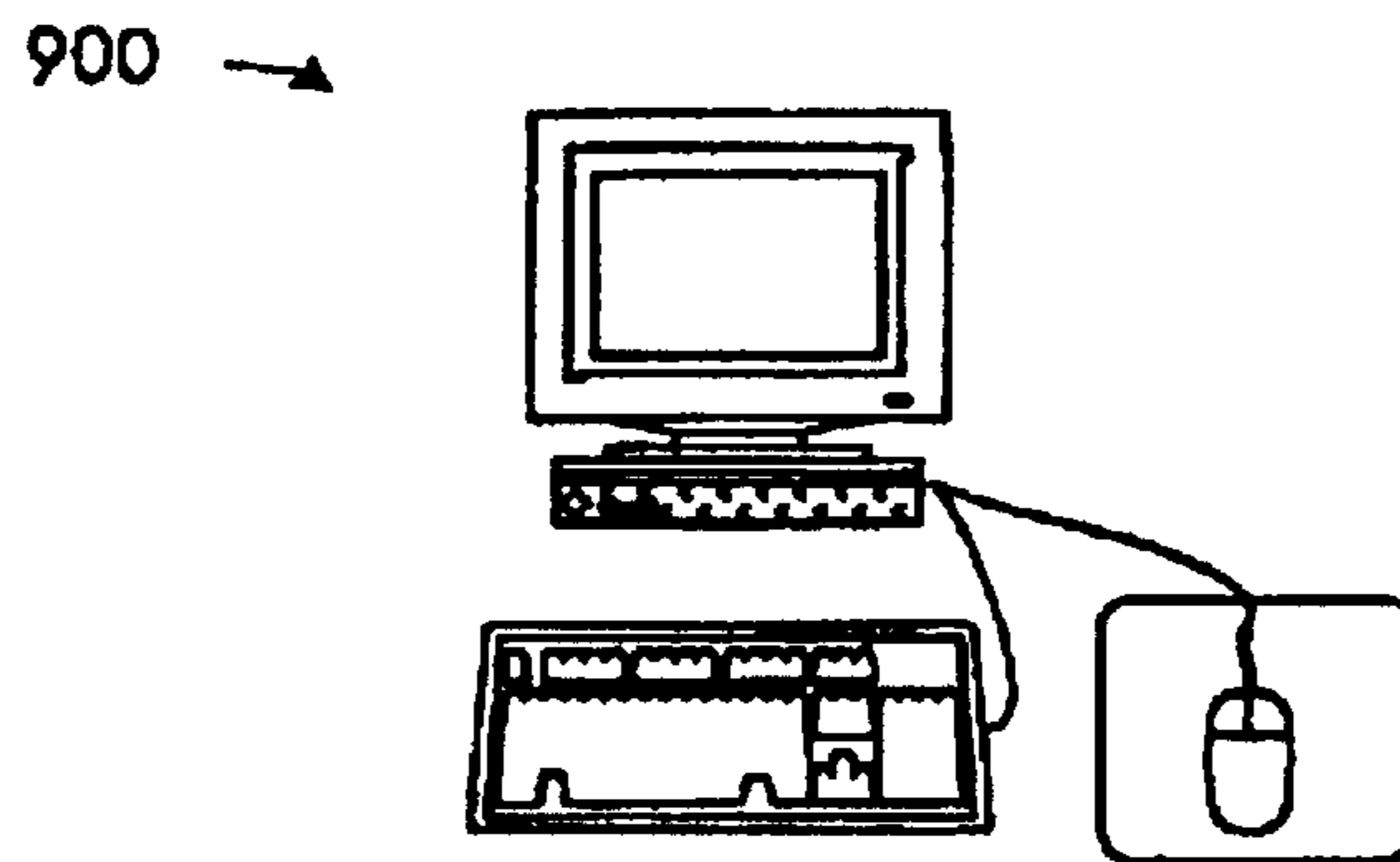

FIG. 9

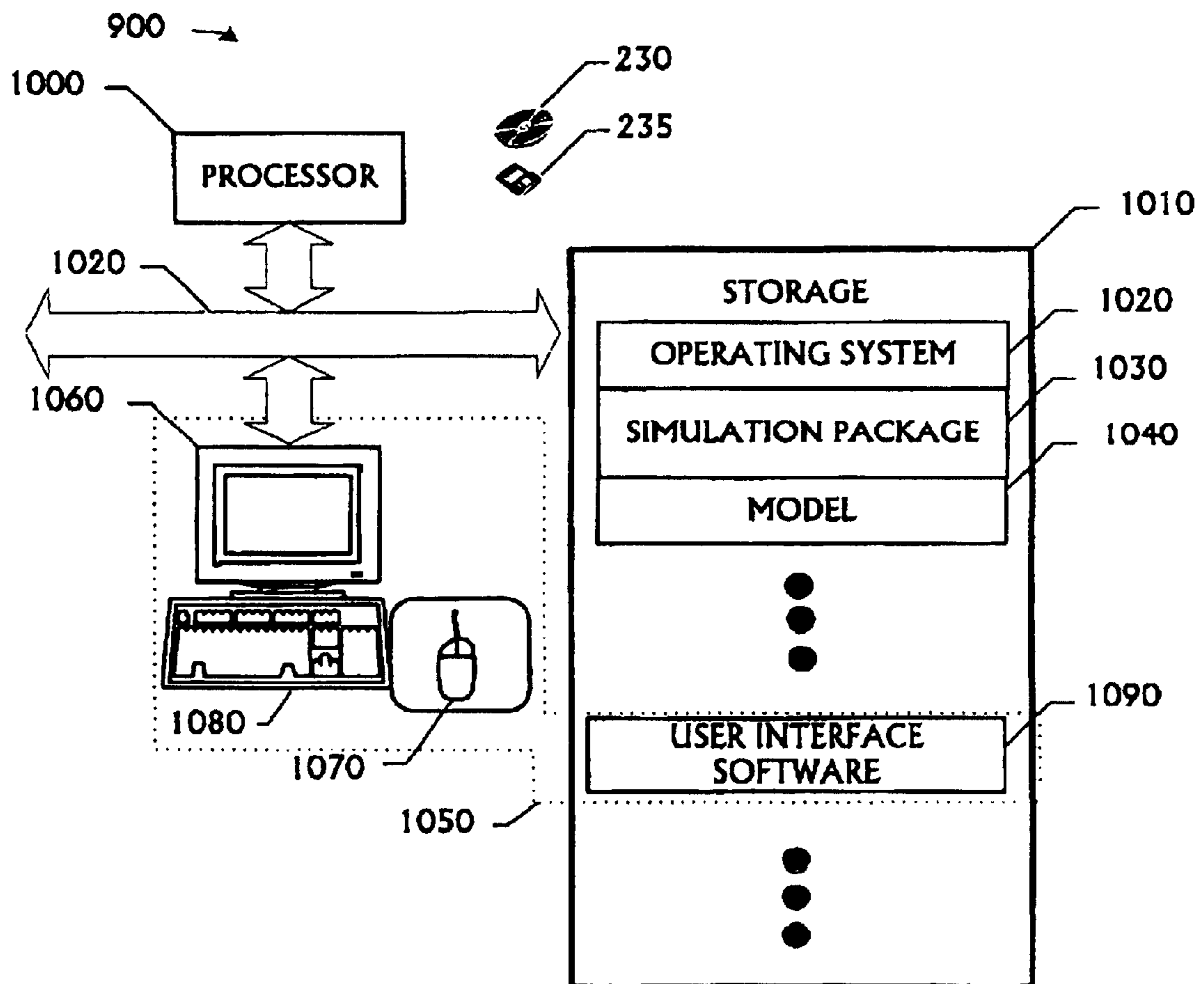

FIG. 10

METHOD AND APPARATUS FOR STRETCHING AN OPTICAL PULSE

Matter enclosed in heavy brackets [] appears in the original patent but forms no part of this reissue specification; matter printed in italics indicates the additions made by reissue.

BACKGROUND OF THE INVENTION

1. Field of the Invention

The present invention pertains to optical pulse stretchers, and, more particularly, to an optical pulse stretcher etalon.

2. Description of the Related Art

The increasing power and speed of many types of electronic systems has focused attention on optical technologies. Optical technologies are attractive for a variety of reasons that may vary depending on the type of technology. However, desirable characteristics typically include generally faster transmission and higher bandwidth of optical signals relative to electrical signals. Information is typically conveyed in optical signals in a series of light pulses, or "optical pulse trains." Frequently, although not always, the optical pulses convey information digitally in 0's and 1's just as electrical pulses in electrical signals do.

Optical technologies are nevertheless not without their own problems. One problem arises from the fleeting nature of the light pulses. Demanding applications employ light pulses of very short duration, e.g., 1 ns or 1 ps, and future increases in capabilities are expected to push pulse widths even lower. Although the signals in optical systems are light pulses, the optical systems themselves employ opto-electronic components that are partly optical and partly electronic. Pulse widths of the magnitudes contemplated herein are difficult for the electronic side of the opto-electronic components to process in a timely fashion.

One solution to this dilemma is to "stretch" the light pulses. One common type of pulse stretcher is the "etalon." An etalon is basically a cavity bounded by two reflective surfaces. One surface is essentially completely reflective, e.g., a mirror. The other surface is partially reflective, i.e., part of the optical signal will reflect off the surface while a portion of the optical signal propagates through the surface. Thus, an optical signal is introduced into the cavity and impinges upon the partially reflective surface first. A portion of the optical signal propagates through the partially reflective surface. A portion also reflects off the partially reflective surface to the fully reflective surface, which then again reflects from the fully reflective portion. The twice reflected portion then impinges upon the partially reflective surface, whereupon the process repeats. The pulse portions propagating through the partially reflective surface are then collected and combined to create a "composite" pulse.

This "composite" pulse is "stretched," i.e., of longer duration than the "base" pulse that was originally directed into the etalon. This technique admirably produces wider, i.e., longer duration, pulses. The stretched pulses are easier for the electrical part of the opto-electronic components to handle and process. However, several drawbacks accompany these pulse stretching techniques.

One significant problem is information loss. For instance, the width of the pulse might carry certain information that can be useful. The spacing of the reflective surfaces in conventional etalons, however, is driven by considerations such as volume and size, as opposed to any characteristic of the light pulses. The characteristics of the resultant stretched

pulse bear no relationship to the characteristics of the base pulse from which such information can be retrieved. Thus, meaningful information that may be conveyed by the width of the base pulse is lost.

Another significant problem impacts the detector that processes that stretched pulses. The stretched pulse typically presents abrupt changes in intensity levels, e.g. from "off" to "on," with very short transition periods. These abrupt transitions can generate a phenomenon known as "ringing" in the detector's electronics. The detector's electronics consequently must be designed to deal with this phenomenon, which complicates the electronics and can increase the space needed for the electronics within the optical system. Complexity is generally proportional to the rate of failure. In some high performance applications, space is at a premium. The need to compensate for ringing can therefore be highly undesirable in some applications.

The present invention is directed to resolving, or at least reducing, one or all of the problems mentioned above.

SUMMARY OF THE INVENTION

The invention, in its various aspect, embodiments, and implementations, is a method and apparatus for stretching a pulse, shaping a stretched pulse, and modeling a stretched and/or shaped pulse.

In a first aspect, the invention includes an etalon comprising a port, a partially reflective surface, and a fully reflective surface. A base pulse may be introduced through the port whereupon it impinges upon the partially reflective surface. The fully reflective surface is spaced apart from the partially reflective surface a distance proportional to the width of the base pulse in operative relationship to the partially reflective surface. In various embodiments, this aspect includes such an etalon employed as a pulse stretcher in an optical system.

In a second aspect, the invention includes a method for shaping an optical pulse. The method comprises introducing a base pulse into an etalon, the etalon including a fully reflective surface spaced apart from a partially reflective surface a distance proportional to the width of the base pulse; collecting a plurality of portions of the base pulse propagating from the etalon; and combining the plurality of portions to generate a stretched pulse whose width is proportional to the width of the base pulse.

In a third aspect, the invention includes a method for modeling an optical pulse stretcher. The method comprises assigning a transmission factor value to each one of a plurality of taps; assigning a reflection factor value to each one of the taps, excepting only one tap; and assigning a transport delay for each tap to which a reflection factor value was assigned, wherein the transport delay is proportional to the width of a base pulse. This third aspect also includes, in its variants, a program storage medium encoded with instructions that perform such a method when executed by a computer and a computer programmed to perform such a method.

BRIEF DESCRIPTION OF THE DRAWINGS

The invention may be understood by reference to the following description taken in conjunction with the accompanying drawings, in which like reference numerals identify like elements, and in which:

FIG. 1 illustrates an optical system receiving an optical pulse train, the optical system employing an optical pulse stretcher in accordance with the present invention;

FIG. 2 depicts the optical pulse train of FIG. 1;

FIG. 3A conceptually illustrates a portion of one particular embodiment of the optical pulse stretcher in the optical system of FIG. 1;

FIG. 3B conceptually illustrates the fabrication of a partially reflective surface in the embodiment of FIG. 3A;

FIG. 4 models the operation of the optical pulse stretcher of the optical system of FIG. 1;

FIG. 5A, FIG. 5B, and FIG. 5C illustrate how manipulating selected reflection and transmission factors in an etalon of the optical pulse stretcher of FIG. 3A can shape the resultant stretched pulse;

FIG. 6A, FIG. 6B, and FIG. 6C illustrate pulse shaping in one particular implementation of the present invention employing a ten-tap etalon;

FIG. 7A and FIG. 7B illustrate pulse shaping in one particular implementation of the present invention employing a nine-tap etalon;

FIG. 8 illustrates a method for shaping a stretched pulse in accordance with one aspect of the present invention;

FIG. 9 depicts a computing apparatus with which the model of FIG. 4 can be implemented and the optical pulse stretcher of FIG. 3A may be simulated;

FIG. 10 illustrates selected portions of the hardware and software architectures of the computing apparatus of FIG. 9; and

FIG. 11 illustrates a method for modeling the optical pulse stretcher of FIG. 1 in accordance with a further aspect of the invention.

While the invention is susceptible to various modifications and alternative forms, specific embodiments thereof have been shown by way of example in the drawings and are herein described in detail. It should be understood, however, that the description herein of specific embodiments is not intended to limit the invention to the particular forms disclosed, but on the contrary, the intention is to cover all modifications, equivalents, and alternatives falling within the spirit and scope of the invention as defined by the appended claims.

DETAILED DESCRIPTION OF THE INVENTION

Illustrative embodiments of the invention are described below. In the interest of clarity, not all features of an actual implementation are described in this specification. It will of course be appreciated that in the development of any such actual embodiment, numerous implementation-specific decisions must be made to achieve the developers' specific goals, such as compliance with system-related and business-related constraints, which will vary from one implementation to another. Moreover, it will be appreciated that such a development effort, even if complex and time-consuming, would be a routine undertaking for those of ordinary skill in the art having the benefit of this disclosure.

FIG. 1 illustrates an optical system 100 receiving an optical pulse train 110, the optical system 100 employing an optical pulse stretcher ("OPS") 120 in accordance with the present invention. The optical system 100 also includes an optical receiver 130 and a detector 140. In general, the optical receiver 130 receives the optical pulse train 110 and transmits the received optical pulse train 110 to the OPS 120 in accordance with conventional practice. The OPS 120 stretches each pulse in the optical pulse train 110. The detector 140 then detects and/or processes the stretched pulses in accordance with conventional practice.

The manner in which the optical receiver 130 and the detector 140 are implemented will depend on the application

of the particular embodiment. For instance, the optical system 100 may be employed, in some embodiments, in an optical computing system or, in alternative embodiments, a laser radar ("LADAR") system. The optical receiver 130 and the detector 140 will be implemented differently in these alternative embodiments because of constraints inherently arising from these diverse applications. However, these implementation specific details will be readily apparent and easily supplemented by those skilled in the art having the benefit of this disclosure.

FIG. 2 conceptually depicts the optical pulse train 110 of FIG. 1. The optical pulse train 110 comprises a plurality of pulses 200, each having a width t_w , spaced apart by duration of t_s . The present invention employs an a priori knowledge of the pulse widths t_w in the design of the OPS 120 as is discussed further below. The amplitude of the individual pulses 200 is immaterial to the practice of the invention, although it may be a design consideration in individual implementations. The manner in which the optical pulse train 110 is generated is likewise immaterial to the practice of the invention. Note that the optical pulse train 110 is periodic.

FIG. 3A conceptually illustrates a portion 300 of one particular embodiment of the optical pulse stretcher 120 in the optical system 100 of FIG. 1. The portion 300 includes an etalon 310, an optical collector 320, and a combiner 325. A base pulse 360 is introduced into the etalon 310. Portions 370, 372, 374, and 376 of the base pulse 360 are collected by the optical collector 320 as they propagate from the etalon 310. The combiner 325 then combines the collected portions 370, 372, 374, and 376 to generate the stretched pulse (not shown in FIG. 3A).

More particularly, the etalon 310 includes a port 330, a partially reflective surface 340, and a fully reflective surface 350. The fully reflective surface 350 is spaced apart from the partially reflective surface 340 a distance D proportional to the width t_w of the base pulse 360. The fully reflective surface 350 is also positioned in operative relationship to the partially reflective surface 340. The phrase "in operative relationship," as used herein, means that an optical signal, or any portion thereof, incident upon the fully reflective surface 350 will be reflected to the partially reflective surface 340. The partially reflective surface 340 and the fully reflective surface 350 bound a cavity 355 through which optical signals and portions thereof propagate as is described further below.

A base pulse 360, which may be any pulse 200 (shown in FIG. 2) of the optical pulse train 110 (first shown in FIG. 1), may be introduced through the port 330. The base pulse 360 impinges upon the partially reflective surface 340, whereupon a portion 370 propagates through the partially reflective surface 340 and a portion 380 is reflected to the fully reflective surface 350. The portion 380 impinges upon the fully reflective surface 350, and is fully reflected back to the partially reflective surface 340.

This process repeats until the energy of the base pulse 360 is dissipated. In the illustrated embodiment of FIG. 3A, this process occurs four times. Portions 372, 374, 376 of the portions 380, 382, 384, respectively, propagate through the partially reflective surface 340 while portions 382, 384 of the portions 380, 382, respectively, are reflected back to the fully reflective surface 350. Note that no portion of the portion 384 impinging upon the partially reflective surface 340 is reflected back since the energy of the base pulse 360 has been dissipated. Note that the number of times portions of the base pulse 360 are reflected back and forth through the cavity 355 will be implementation specific, depending upon

the amount of each reflection from the partially reflective surface **340**. Thus, although four such reflections are shown, there may be any number.

The partially reflective surface **340** may, in some embodiments, be fabricated in accordance with conventional practice. The partially reflective surface **340** comprises a coating **385a** on a substrate **390a**. The coating **385a** may be, for example, a Titanium/Gold (Ti/Au) coating, where the Ti is 15–50 Å thick and the Au is 100–2000 Å thick. The substrate **390a** may be, for example, a glass or sapphire substrate.

Turning now to FIG. **3B**, the partially reflective surface **340** may be deposited on a substrate **392**, such as sapphire (crystalline Al_2O_3) or optical glass. In a Ti/Au coating, Ti plays the role of an adhesion layer **394**, and needs to be no thicker than 50 Å. The Ti may be deposited by standard thin film metal deposition process such as sputtering or electron-beam evaporation. The thickness of this adhesion layer **394** would be uniform throughout the substrate surface **396**.

The reflective layer **398**, of Au, for instance, is intentionally graded from one end **391** to the other end **393**, as illustrated in FIG. **3B**. As an example, one edge of a square section of the substrate surface could be 100 Å (e.g., at the end **391**) that continuously increases to 1500 Å (e.g., at the end **393**). The graded thickness would result in the thinner region being only slightly reflective and highly transmissive to a gradually thicker region that would be almost entirely reflective.

Still referring to FIG. **3B**, the deposition of the film with graded thickness for the reflective layer **398** can be achieved by controlling the temperature during deposition across the substrate **392**, from one edge of the square to the opposite edge (e.g., from the end **391** to the end **393**). The deposition technique could be evaporation or metalorganic chemical vapor deposition (“MOCVD”). The substrate **392** is heated on a heating block **395** (made of pyrolytic graphite, for example) in which the temperature is varied in a controlled manner. More particularly, the heating block **395** is heated with a row of lamp heaters **397** (e.g., infrared lamps) in which the currents are controlled individually with standard temperature controllers and the temperature is monitored with multiple thermocouple gauges. The individual heating lamps **397** are heated with varying currents to achieve a temperature gradient.

Returning to FIG. **3A**, the fully reflective surface **350** may also be, in some embodiments, fabricated in accordance with conventional practice. The fully reflective surface **350** comprises a coating **385b** on a substrate **390b**. Note that no surface is truly 100% reflective because light can be expected to propagate through practically any material to at least some degree. However, many materials reflect such a substantial portion of any optical signal incident upon them that they are considered by those in the art to be “fully reflective.” Any such material is suitable for the coating **385b**. For instance, the coating **385b** may provide a mirrored finish that would be considered “fully reflective.” One suitable, commercially available material for the coating **385b** would be Gold. The substrate **390b** may be fabricated from the same material as the substrate **390a**, although this is not necessary to the practice of the invention.

As was mentioned earlier, the fully reflective surface **350** is spaced apart from the partially reflective surface **340a** distance D proportional to the width t_w of the base pulse **360**. In the illustrated embodiment, the distance D is calculated so that the propagation time for an optical signal to be reflected off the partially reflective surface **340**, propagate to the fully

reflective surface **350**, reflect off the fully reflective surface **350**, and propagate back to the partially reflective surface **340** is equal to the width t_w of the base pulse **360**. Stated in a more mathematical fashion:

$$t_w = t_1 + t_2$$

where:

t_w = the width of the base pulse **360**, as was defined above;
 t_1 = the time it takes for a portion (e.g., the portion **380**) of an optical signal (e.g., the base pulse **360**) to reflect off the partially reflective surface **340** and propagate to the fully reflective surface **350**; and

t_2 = the time it takes for a portion of an optical signal to reflect off the fully reflective surface and propagate to the partially reflective surface **340**.

Thus, the etalon **310** can be said to be “matched” to the base pulse **360**.

Note that the speed at which the optical signal will propagate will depend on the medium, if any, inhabiting the cavity **355**. The optical signal will propagate faster in a vacuum, for instance, than in an atmosphere of, for example, air. The optical signal will propagate more slowly in a medium more viscous than air. As will be apparent to those skilled in the art having the benefit of this disclosure will appreciate, variations in the propagation velocities may be compensated for, in some embodiments, by altering the size and/or volume of the cavity **355** for the etalon.

However, the cavity **355** will typically be filled with an atmosphere of air. Thus, where the individual pulses **200** (shown in FIG. **2**) of the optical pulse train **110** (first shown in FIG. **1**) have a pulse width $t_w = 1$ ns the etalon **310** will typically have a separation D between the two surfaces **340** and **350** of approximately 6". It follows that where $t_w = 1$ ps the etalon **310** will typically have a separation D between the two surfaces **340**, **350** of approximately .006".

Still referring to FIG. **3A**, the optical collector **320** and the combiner **325** may be implemented using any suitable technique known to the art. In the illustrated embodiment, the optical collector **320** comprises a lens. The combiner **325** will typically include optical detector(s) (not shown) and combinatorial electronic logic (also not shown). Note that the combiner **325** may, in some embodiments comprise a portion of the detector **140** (shown in FIG. **1**).

Note that, because the distance D is proportional to the width of the base pulse **360**, so will be the width of the stretched pulse (not shown). In particular, where the distance D is calculated so that the propagation time $t_1 + t_2 = t_w$ as was discussed above for the illustrated embodiment, the width of the stretched pulse will be directly proportional to the width t_w of the base pulse **360**. In fact, the width of the stretched pulse in the illustrated embodiment is an integer multiple of the width of the base pulse **360**. Thus, the information carried by the width of the base pulse **360** can be retrieved from the width of the stretched pulse.

FIG. **4** models the operation of the OPS **120** of FIG. **1**. The model **400** comprises the optical pulse train **110** (first shown in FIG. **1**), an optical signal channel (“OSC”) **410**, a plurality of transmission factors **420**, a plurality of reflection factors **430**, and a plurality of transport delays **440**. The OSC **410** represents the path of the optical pulse train **110** including reception by the optical receiver **330** and transmission paths prior to reception. The transmission factors **420** represent the percentage of an optical signal that propagates through the partially reflective surface **340** when it impinges thereon. The reflection factors **430** represent the percentage

7

of an optical signal that is reflected when it impinges on the partially reflective surface 340. The transport delays 440 represent the propagation time t_1+t_2 discussed above for the reflected portion to travel to and reflect off the fully reflective surface 350 and back to the partially reflective surface 340.

More particularly, the elements of the model 400 can be correlated to the operation of the OPS 120 as illustrated in FIG. 3A, as follows:

T_1 =percentage of the base pulse 360 propagating through the partially reflective surface 340 when it impinges thereon;

R_1 =percentage of the base pulse 360 reflected as the reflected portion 380 when the base pulse 360 impinges on the partially reflective surface 340;

T_2 =percentage of the reflected portion 380 propagating through the partially reflective surface 340 when it impinges thereon;

R_2 =percentage of the reflected portion 380 reflected as the reflected portion 382 when the reflected portion 380 impinges on the partially reflective surface 340;

T_3 =percentage of the reflected portion 382 propagating through the partially reflective surface 340 when it impinges thereon;

R_3 =percentage of the reflected portion 382 reflected as the reflected portion 384 when the reflected portion 382 impinges on the partially reflective surface 340; and

T_4 =percentage of the reflected portion 384 propagating through the partially reflective surface 340 when it impinges thereon.

Note that the transport delays 440 are constant throughout the model and the values are determined by the pulse width t_w , as discussed above. Note also that there are no transmission factors 420 or reflection factors 430 associated with the fully reflective surface 350.

In accordance with another aspect of the present invention, the shape of the stretched pulse 460 can be controlled by manipulating the values of the transmission factors 420 and the reflection factors 430. This shaping can be achieved in the physical implementation of FIG. 3A by grading the coating 385a of the partially reflective surface 340. The coating 385a can be graded by varying the thickness and/or density of the material of the coating 385a across the substrate 390a. Techniques for grading partially reflective surfaces in this manner are known in other optics applications, such as the manufacture of telescopes and microscopes. Such techniques may be employed to grade the coating 385a to control the transmission factor of the partially reflective surface 340 as desired in selective locations.

Consider, for instance, one particular implementation of the OPS 120 represented by the model 500 in FIG. 5A. Note that there are five reflections off and six transmissions through the partially reflective surface 340 (shown in FIG. 3A) in this particular implementation. Thus, the OPS 120 modeled in FIG. 5A can be referred to as a six tap OPS. Assume that the values of the transmission factors 530 and the reflection factors 530 remain constant (i.e., $T_1=T_2=T_3=T_4=T_5=T_6$ and $R_1=R_2=R_3=R_4=R_5$). The resultant stretched pulse 560 generated by the combiner 325 would look something like the stretched pulse 570 shown in FIG. 5B. However, if the values of the transmission factors 530 and the reflection factors 530 are varied as with a quadratic, e.g., \cos^2 , the resultant stretched pulse 560 generated by the combiner 325 would look something like the stretched pulse 575 shown in FIG. 5C. Note that the transport delays 540 do not affect the shape of the stretched pulse 560.

For a more concrete example, consider a 10-tap implementation of the OPS 120 in FIG. 1 modeled in FIG. 6A.

8

Assume that, in the model 600, the transmission factors and reflection factors are constant throughout the model 600, and are assigned the values in Table 1 and Table 2, respectively.

TABLE 1

Transmission Factor Values for FIG. 6A	
T_1	0.09
T_2	0.09
T_3	0.09
T_4	0.09
T_5	0.09
T_6	0.09
T_7	0.09
T_8	0.09
T_9	0.09
T_{10}	0.09

TABLE 2

Reflection Factor Values for FIG. 6A	
R_1	0.90
R_2	0.90
R_3	0.90
R_4	0.90
R_5	0.90
R_6	0.90
R_7	0.90
R_8	0.90
R_9	0.90

The values will generate a stretched pulse 660 shaped like the pulse 670 in FIG. 6B, i.e., a "staircase" pulse. However, if the transmission factors and reflection factors are assigned the values in Table 3 and Table 4, respectively, then the resultant stretched pulse 660 will be a square, like the pulse 675 in FIG. 6C.

TABLE 3

Transmission Factor Values for FIG. 6A	
T_1	0.10
T_2	0.11
T_3	0.13
T_4	0.14
T_5	0.17
T_6	0.20
T_7	0.25
T_8	0.33
T_9	0.05
T_{10}	1.00

TABLE 4

Reflection Factor Values for FIG. 6A	
R_1	0.90
R_2	0.89
R_3	0.88
R_4	0.86
R_5	0.83
R_6	0.80
R_7	0.75
R_8	0.67
R_9	0.50

As was noted above, pulses presenting sharp transitions—like the pulses 670, 675 in FIG. 6B and FIG. 6C, respectively—can produce ringing in detectors' electronics.

The transmission and reflection values can also be manipulated to produce shaped pulses that do not provoke ringing, such as the pulse **575** in FIG. **5C**. Generally speaking, this may be more easily accomplished with an odd number of taps. FIG. **7A** presents a model **700** of a 9-tap OPS. If the transmission and reflection factors are assigned the values set forth in Table 5 and Table 6, respectively, the stretched pulse **760** will look like the pulse **770** in FIG. **7B**.

TABLE 5

Transmission Factor Values for FIG. 7A	
T ₁	0.02
T ₂	0.07
T ₃	0.14
T ₄	0.23
T ₅	0.33
T ₆	0.45
T ₇	0.60
T ₈	0.78
T ₉	1.00

TABLE 6

Reflection Factor Values for FIG. 7A	
R ₁	0.98
R ₂	0.93
R ₃	0.86
R ₄	0.77
R ₅	0.67
R ₆	0.55
R ₇	0.40
R ₈	0.22

Note, however, that stretched pulses shaped like the pulses **575** and **770** may be achieved with even numbers of taps.

Thus, another aspect of the present invention is a method for shaping a stretched pulse. FIG. **8** illustrates a method **800** by which this may be done in accordance with the present invention. The method **800** begins by grading a partially reflective surface of an etalon to weight a plurality of taps of the etalon (at **810**). Next, a base pulse is introduced into the etalon (at **820**). The portions of the base pulse propagating through the graded partially reflective surface are then collected (at **830**) and combined to generate the shaped, stretched pulse (at **840**).

A model such as the model **400** can be employed in commonly used computerized simulation packages to help design and test designs of various embodiments of the OPS **120**. FIG. **9** depicts a computing apparatus **900** programmed to model the OPS **120** and to simulate the operation of a physical implementation using that model. The computing apparatus **900** is a workstation, but may be virtually any type of computing apparatus, e.g., a desktop personal computer, or a laptop computer, provided suitable modeling and simulation software can be run thereon. The make and model of the workstation are, similarly, not material to the practice of the invention.

Selected portions of the hardware and software architectures of the computing apparatus **900** are shown in FIG. **10**. The computing apparatus **9** includes a processor **1000** communicating with storage **1010** over a bus system **1020**. The storage **1010**, typically including a hard disk and RAM ("random access memory"), is encoded with an operating system **1020**, a simulation package **1030**, and a model **1040**.

A designer interacts with the operating system **1020** through the user interface **1050**, comprising the monitor **1060**, mouse **1070**, keyboard **1080**, and user interface software **1090**, to invoke the simulation package **1030**. The designer then uses the simulation package **1030** to design and test the model **1040**. One suitable, commercially available, off-the shelf simulation package is MATLAB™, including the Simulink toolboxes. Various versions of MATLAB are well known and widely available in the art.

The designer builds the model **1040** from within the simulation package **1030**. The model **1040** may be stored, if desired. The OSC **410** (shown in FIG. **4**) can be modeled by a general Additive White Gaussian Noise Element ("AWGN"). The model **1040** can then be applied using the simulation package **1030**. The results from this simulation can then be evaluated determine whether the modeled design will provide acceptable performance for the intended application.

Thus, a further aspect of the present invention is a method for modeling the OPS **120**. FIG. **11** illustrates one embodiment of such a method for modeling the OPS **120**. The method **1100** begins by assigning a transmission factor value to each one of a plurality of taps (at **1110**). Next, a reflection factor value is assigned to each one of the taps, excepting only one tap (at **1120**). A transport delay is assigned for each tap to which a reflection factor value was assigned, wherein the transport delay is proportional to the width of a base pulse (at **1130**). Note that the order in which these acts are performed is not material to the practice of the invention, and that they may be performed in any order.

The model is software implemented, and so various manifestations of this aspect include instructions encoded on a program storage medium that, when executed by a computer, perform such a method and a computing apparatus programmed to perform such a method. The program storage medium may be magnetic (e.g., the floppy disk **1085** in FIG. **10** or a hard disk) or optical (e.g., the compact disk read only memory, or "CD ROM" **1095** in FIG. **10**), and may be read only or random access. Similarly, as was mentioned above, the computing apparatus may be any computer on which suitable software can be loaded and executed, e.g., the workstation **900**. The invention is not limited by these aspects of any given implementation.

Some portions of the detailed descriptions herein are presented in terms of a software implemented process involving symbolic representations of operations on data bits within a memory in a computing system or a computing device. These descriptions and representations are the means used by those in the art to most effectively convey the substance of their work to others skilled in the art. The process and operation require physical manipulations of physical quantities. Usually, though not necessarily, these quantities take the form of electrical, magnetic, or optical signals capable of being stored, transferred, combined, compared, and otherwise manipulated. It has proven convenient at times, principally for reasons of common usage, to refer to these signals as bits, values, elements, symbols, characters, terms, numbers, or the like.

It should be borne in mind, however, that all of these and similar terms are to be associated with the appropriate physical quantities and are merely convenient labels applied to these quantities. Unless specifically stated or otherwise as may be apparent, throughout the present disclosure, these descriptions refer to the action and processes of an electronic device, that manipulates and transforms data represented as physical (electronic, magnetic, or optical) quantities within some electronic device's storage into other data similarly

11

represented as physical quantities within the storage, or in transmission or display devices. Exemplary of the terms denoting such a description are, without limitation, the terms “processing,” “computing,” “calculating,” “determining,” “displaying,” and the like.

This concludes the detailed description. The particular embodiments disclosed above are illustrative only, as the invention may be modified and practiced in different but equivalent manners apparent to those skilled in the art having the benefit of the teachings herein. Furthermore, no limitations are intended to the details of construction or design herein shown, other than as described in the claims below. It is therefore evident that the particular embodiments disclosed above may be altered or modified and all such variations are considered within the scope and spirit of the invention. Accordingly, the protection sought herein is as set forth in the claims below.

What is claimed:

1. An etalon, comprising:

a port through which a base pulse may be introduced;

a partially reflective surface against which the base pulse may impinge; and

a fully reflective surface spaced apart from the partially reflective surface in operative relationship to the partially reflective surface, the distance between the fully reflective and partially reflective surfaces being a function of predetermined proportionality between the width of an output pulse and the width of the base pulse.

2. The etalon of claim 1, wherein the partially reflective surface is graded.

3. The etalon of claim 1, wherein the distance is determined so that the time for an optical signal to reflect off the partially reflective surface, propagate to the fully reflective surface, reflect off the fully reflective surface, and propagate to the partially reflective surface is equal to an integer multiple of the width of the base pulse.

4. The etalon of claim 1, wherein at least one of the partially reflective surface and the fully reflective surface includes:

a substrate; and

a coating on the substrate.

5. The etalon of claim 4, wherein the coating on the substrate is graded.

6. The etalon of claim 4, wherein the coating comprises a Ti/Au coating and the substrate comprises an optical glass or a sapphire.

7. The etalon of claim 4, wherein the coating comprises a Au coating and the substrate comprises an optical glass or a sapphire.

8. An etalon, comprising:

means for introducing a base pulse into a cavity defined by the etalon;

means for partially reflecting the base pulse; and

means for fully reflecting the partially reflected base pulse spaced apart from the partially reflecting means in operative relationship thereto, the fully reflecting means being spaced apart from the partially reflective means a distance being a function of predetermined proportionality between the width of an output pulse and the width of the base pulse.

9. The etalon of claim 8, wherein the partially reflective means is graded.

10. The etalon of claim 8, wherein the distance is determined so that the time for an optical signal to reflect off the partially reflective means, propagate to the fully reflective

12

means, reflect off the fully reflective means, and propagate to the partially reflective means is equal to an integer multiple of the width of the base pulse.

11. The etalon of claim 8, wherein at least one of the partially reflective means and the fully reflective means includes:

a substrate; and

a coating on the substrate.

12. An optical pulse stretcher, comprising:

a port through which a base pulse may be introduced;

a partially reflective surface against which the base pulse may impinge;

a fully reflective surface spaced apart from the partially reflective surface a distance that is a function of predetermined proportionality between the width of an output pulse and the width of the base pulse and in operative relationship to the partially reflective surface;

an optical collector capable of collecting a plurality of base pulse components propagating through the partially reflective surface; and

a combiner capable of combining the collected base pulse components and outputting a stretched pulse.

13. The optical pulse stretcher of claim 12, wherein the partially reflective surface is graded.

14. The optical pulse stretcher of claim 12, wherein the distance is determined so that the time for an optical signal to reflect off the partially reflective surface, propagate to the fully reflective surface, reflect off the fully reflective surface, and propagate to the partially reflective surface is equal to an integer multiple of the width of the base pulse.

15. The optical pulse stretcher of claim 12, wherein at least one of the partially reflective surface and the fully reflective surface includes:

a substrate; and

a coating on the substrate.

16. The optical pulse stretcher of claim 15, wherein the coating on the substrate is graded.

17. The optical pulse stretcher of claim 15, wherein the coating comprises a Ti/Au coating and the substrate comprises an optical glass or a sapphire.

18. The optical pulse stretcher of claim 15, wherein the coating comprises a Au coating and the substrate comprises an optical glass or a sapphire.

19. The optical pulse stretcher of claim 12, wherein the optical collector comprises a lens.

20. An optical system, comprising:

an optical receiver capable of receiving an optical signal;

an optical pulse stretcher, including:

a port through which a base pulse of the optical signal may be introduced;

a partially reflective surface against which the base pulse may impinge;

a fully reflective surface spaced apart from the partially reflective surface a distance that is a function of predetermined proportionality between the width of an output pulse and the width of the base pulse and in operative relationship to the partially reflective surface;

an optical collector capable of collecting a plurality of base pulse components propagating through the partially reflective surface; and

a combiner capable of combining the collected base pulse components and outputting a stretched pulse; and

a detector capable of processing the stretched pulse.

13

21. The optical system of claim 20, wherein the partially reflective surface is graded.

22. The optical system of claim 20, wherein the distance is determined so that the time for an optical signal to reflect off the partially reflective surface, propagate to the fully reflective surface, reflect off the fully reflective surface, and propagate to the partially reflective surface is equal to an integer multiple of the width of the base pulse.

23. The optical system of claim 20, wherein at least one of the partially reflective surface and the fully reflective surface includes:

- a substrate; and
- a coating on the substrate.

24. The optical system of claim 23, wherein the coating on the substrate is graded.

25. The optical system of claim 23, wherein the coating comprises a Ti/Au coating and the substrate comprises an optical glass or a sapphire.

26. The optical system of claim 23, wherein the coating comprises a Au coating and the substrate comprises an optical glass or a sapphire.

27. The optical system of claim 20, wherein the optical collector comprises a lens.

28. A method for stretching an optical pulse, comprising:

introducing a base pulse into an etalon, the etalon including a fully reflective surface spaced apart from a partially reflective surface a distance that is a function of a predetermined proportionality between the width of an output pulse and the width of the base pulse;

collecting a plurality of portions of the base pulse propagating from the etalon; and

combining the plurality of portions to generate a stretched pulse whose width is proportional to the width of the base pulse.

29. The method of claim 28, wherein collecting the plurality of portions includes focusing the portions on a combiner.

30. The method of claim 28, wherein combining the portions to generate a stretched pulse includes combining the portions to generate a shaped, stretched pulse.

31. The method of claim 30, wherein combining the collected portions to generate the shaped, stretched pulse includes combining the collected portions to generate a pulse having a shape selected from the group consisting of a staircase, a square, and a sinusoid.

32. The method of claim 28, further comprising grading the partially reflective surface.

33. The method of claim 32, wherein grading the partially reflective surface includes varying the thickness or density of a coating on a substrate.

34. An etalon, comprising:

a partially reflective surface against which a base pulse may impinge; and

a fully reflective surface spaced apart from the partially reflective surface in operative relationship to the partially reflective surface, the distance between the fully reflective and partially reflective surfaces being a function of predetermined proportionality between the width of an output pulse and the width of the base pulse.

35. The etalon of claim 34, wherein the partially reflective surface is graded.

36. The etalon of claim 34, wherein the predetermined proportionality is equal to an integer multiple of the width of the base pulse.

14

37. The etalon of claim 34, wherein the partially reflective surface includes:

- a substrate; and
- a coating on the substrate.

38. The etalon of claim 37, wherein the coating on the substrate is graded.

39. The etalon of claim 37, wherein the coating comprises a Ti/Au coating and the substrate comprises an optical glass or a sapphire.

40. The etalon of claim 37, wherein the coating comprises a Au coating and the substrate comprises an optical glass or a sapphire.

41. The etalon of claim 34, wherein the etalon is based on an etalon design having a plurality of taps, each tap having a selected transmission factor value, each tap except one having a selected reflection factor value, and each tap having a selected reflection factor value having a selected transport delay value.

42. An etalon, comprising:

means for partially reflecting a base pulse; and

means for fully reflecting the partially reflected base pulse spaced apart from the partially reflecting means in operative relationship thereto, the fully reflecting means being spaced apart from the partially reflective means a distance being a function of predetermined proportionality between the width of an output pulse and the width of the base pulse.

43. The etalon of claim 42, wherein the plurality reflective means is graded.

44. The etalon of claim 42, wherein the predetermined proportionality is equal to an integer multiple of the width of the base pulse.

45. The etalon of claim 42, wherein the partially reflective means includes:

- a substrate; and
- a coating on the substrate.

46. The etalon of claim 42, wherein the etalon is based on an etalon design having a plurality of taps, each tap having a selected transmission factor, each tap except one having a selected reflection factor, and each tap having a selected reflection factor having a selected transport delay, the selected transport delay being proportional to the width of a base pulse.

47. An optical pulse stretcher, comprising:

a partially reflective surface against which a base pulse may impinge;

a fully reflective surface spaced apart from the partially reflective surface a distance that is a function of predetermined proportionality between the width of an output pulse and the width of the base pulse and in operative relationship to the partially reflective surface; an optical collector capable of collecting a plurality of base pulse components propagating through the partially reflective surface; and

a combiner capable of combining the collected base pulse components and outputting a stretched pulse.

48. The optical pulse stretcher of claim 47, wherein the partially reflective surface is graded.

49. The optical pulse stretcher of claim 47, wherein the predetermined proportionality is equal to an integer multiple of the width of the base pulse.

50. The optical pulse stretcher of claim 47, wherein the partially reflective surface includes:

- a substrate; and
- a coating on the substrate.

51. The optical pulse stretcher of claim 50, wherein the coating on the substrate is graded.

52. The optical pulse stretcher of claim 50, wherein the coating comprises a Ti/Au coating and the substrate comprises an optical glass or a sapphire.

53. The optical pulse stretcher of claim 50, wherein the coating comprises a Au coating and the substrate comprises an optical glass or a sapphire.

54. The optical pulse stretcher of claim 47, wherein the optical collector comprises a lens.

55. The optical pulse stretcher of claim 47, wherein the optical pulse stretcher is based on an optical pulse stretcher design having a plurality of taps, each tap having a selected transmission factor value, each tap except one having a selected reflection factor value, and each tap having a selected reflection factor value having a selected transport delay value.

56. An optical system, comprising:

an optical receiver capable of receiving an optical signal;
an optical pulse stretcher, including:

a partially reflective surface against which a base pulse may impinge;

a fully reflective surface spaced apart from the partially reflective surface a distance that is a function of predetermined proportionality between the width of an output pulse and the width of the base pulse and in operative relationship to the partially reflective surface;

an optical collector capable of collecting a plurality of base pulse components propagating through the partially reflective surface; and

a combiner capable of combining the collected base pulse components and outputting a stretched pulse; and

a detector capable of processing the stretched pulse.

57. The optical system of claim 56, wherein the partially reflective surface is graded.

58. The optical system of claim 56, wherein the predetermined proportionality is equal to an integer multiple of the width of the base pulse.

59. The optical system of claim 56, wherein the partially reflective surface includes:

a substrate; and

a coating on the substrate.

60. The optical system of claim 59, wherein the coating on the substrate is graded.

61. The optical system of claim 59, wherein the coating comprises a Ti/Au coating and the substrate comprises an optical glass or a sapphire.

62. The optical system of claim 59, wherein the coating comprises a Au coating and the substrate comprises an optical glass or a sapphire.

63. The optical system of claim 56, wherein the optical collector comprises a lens.

64. The optical system of claim 56, wherein the optical pulse stretcher is based on an etalon design having a plurality of taps, each tap having a selected transmission factor value, each tap except one having a selected reflection factor value, and each tap having a selected reflection factor value having a selected transport delay value.

65. A method for stretching an optical pulse, comprising: introducing a base pulse into an etalon, the etalon including a fully reflective surface spaced apart from a partially reflective surface a distance that is a function of a predetermined proportionality between the width of an output pulse and the width of the base pulse; and

combining a plurality of portions of the base pulse propagating from the etalon to generate a stretched pulse whose width is proportional to the width of the base pulse.

66. The method of claim 65, wherein collecting the plurality of portions includes focusing the portions on a combiner.

67. The method of claim 65, wherein combining the portions to generate a stretched pulse includes combining the portions to generate a shaped, stretched pulse.

68. The method of claim 65, wherein combining the collected portions to generate the shaped, stretched pulse includes combining the collected portions to generate a pulse having a shape selected from the group consisting of a staircase, a square, and a sinusoid.

69. The method of claim 65, further comprising grading the partially reflective surface.

70. The method of claim 69, wherein grading the partially reflective surface includes varying the thickness or density of a coating on a substrate.

71. The method of claim 65, wherein the partially reflective surface is a graded, partially reflective surface,

wherein collecting a plurality of portions of the base pulse propagating from the etalon includes collecting a plurality of portions of the base pulse propagating through the graded, partially reflective surface, and

wherein combining the plurality of portions includes generating a shaped, stretched pulse.

72. The method of claim 65, wherein collecting the plurality of portions includes focusing the portions on a combiner.

73. The method of claim 65, wherein combining the collected portions to generate the shaped, stretched pulse includes combining the collected portion to generate a pulse having a shape selected from the group of a staircase, a square and a sinusoid.

74. The method of claim 65, further comprising grading the partially reflective surface.

75. The method according to claim 74, wherein grading the partially reflective surface includes varying the thickness or density of a coating on a substrate.

76. The method of claim 65, wherein the etalon is based on an etalon design having a plurality of taps,

the method further comprising modeling the etalon comprising:

assigning a selected transmission factor value to each one of a plurality of taps;

assigning a selected reflection factor value to each one of the taps, excepting only one tap; and

assigning a selected transport delay for each tap to which a reflection factor value was assigned.