

US00RE41062E

(19) **United States**  
(12) **Reissued Patent**  
**Yaniv**

(10) **Patent Number:** **US RE41,062 E**  
(45) **Date of Reissued Patent:** **Dec. 29, 2009**

(54) **IMAGE PROJECTION SYSTEM**  
(75) Inventor: **Zvi Yaniv**, Austin, TX (US)  
(73) Assignee: **Novus Displays, LLC**, Cincinnati, OH (US)  
(21) Appl. No.: **11/101,364**  
(22) Filed: **Apr. 7, 2005**

6,483,643 B1 \* 11/2002 Zuchowski ..... 359/443  
6,572,232 B2 \* 6/2003 Yaniv ..... 353/98  
6,577,355 B1 \* 6/2003 Yaniv ..... 349/16  
6,588,909 B2 7/2003 Yaniv et al.  
6,616,284 B2 9/2003 Yaniv et al.  
6,726,335 B2 \* 4/2004 Yaniv et al. .... 353/98  
6,854,850 B2 2/2005 Yaniv  
7,057,578 B2 6/2006 Yaniv  
2003/0020879 A1 \* 1/2003 Sonehara ..... 353/7

**Related U.S. Patent Documents**

Reissue of:

(64) Patent No.: **6,572,232**  
Issued: **Jun. 3, 2003**  
Appl. No.: **09/876,400**  
Filed: **Jun. 7, 2001**

U.S. Applications:

(63) Continuation-in-part of application No. 09/519,537, filed on Mar. 6, 2000, now Pat. No. 6,577,355.

(51) **Int. Cl.**  
**G03B 21/28** (2006.01)  
**G02B 5/32** (2006.01)  
**G02F 1/1335** (2006.01)

(52) **U.S. Cl.** ..... **353/79; 353/88; 353/98; 359/449**

(58) **Field of Classification Search** ..... **353/28, 353/79, 88, 122; 359/443, 452, 453, 449**  
See application file for complete search history.

(56) **References Cited**

**U.S. PATENT DOCUMENTS**

3,650,608 A \* 3/1972 Baker ..... 353/69  
5,123,192 A \* 6/1992 Hsieh ..... 40/442  
5,175,637 A \* 12/1992 Jones et al. .... 349/1  
5,243,413 A \* 9/1993 Gitlin et al. .... 348/269  
5,416,617 A \* 5/1995 Loiseaux et al. .... 359/51  
5,644,369 A \* 7/1997 Jachimowicz et al. .... 349/10  
5,784,138 A \* 7/1998 Kollarits et al. .... 349/93  
5,813,742 A \* 9/1998 Gold et al. .... 353/88  
5,940,150 A \* 8/1999 Faris et al. .... 349/16  
6,092,900 A \* 7/2000 Diedrich et al. .... 353/122  
6,122,023 A \* 9/2000 Chen et al. .... 349/86  
6,220,711 B1 \* 4/2001 Melville ..... 353/28  
6,392,726 B2 \* 5/2002 Goto et al. .... 349/86

**OTHER PUBLICATIONS**

Doane, J.W. et al., Displays from a New Type of Liquid Crystal Microdroplet Dispersion, IEEE, 1985 International Display Research Conference, pp. 153–154 (1985).

Doane, J.W. et al., Wide-Angle-View PDLC Displays, SID 90 Digest, pp. 224–226 (1990).

Yaniv, Z. et al., Active Matrix Polymer Dispersed Liquid Crystal Display, Japan Display, pp. 572–575 (1989).

Office Action for U.S. Appl. No. 09/519,537 (Pat. No. 6,577,355) dated Sep. 6, 2002.

Notice of Allowance for U.S. Appl. No. 09/519,537 (Pat. No. 6,577,355) dated Dec. 27, 2002.

\* cited by examiner

*Primary Examiner*—William C. Dowling

(74) *Attorney, Agent, or Firm*—Frost Brown Todd LLC

(57) **ABSTRACT**

An image projection system comprises an image projector, such as a film or television projector and a projection screen. The projection screen is fabricated of a substantially transparent material, such as glass or plastic. The screen of transparent material has one or more areas or portions formed therein which areas or portions may be made to be translucent upon the application of a stimulus. Once in a translucent condition, the projected image can be received and viewed on the translucent portion. A mirror can be positioned behind the projection screen so that a person can view the reflection of themselves in the mirror when the screen is transparent, and an image can be projected when the projection screen is made to be substantially translucent.

**27 Claims, 6 Drawing Sheets**

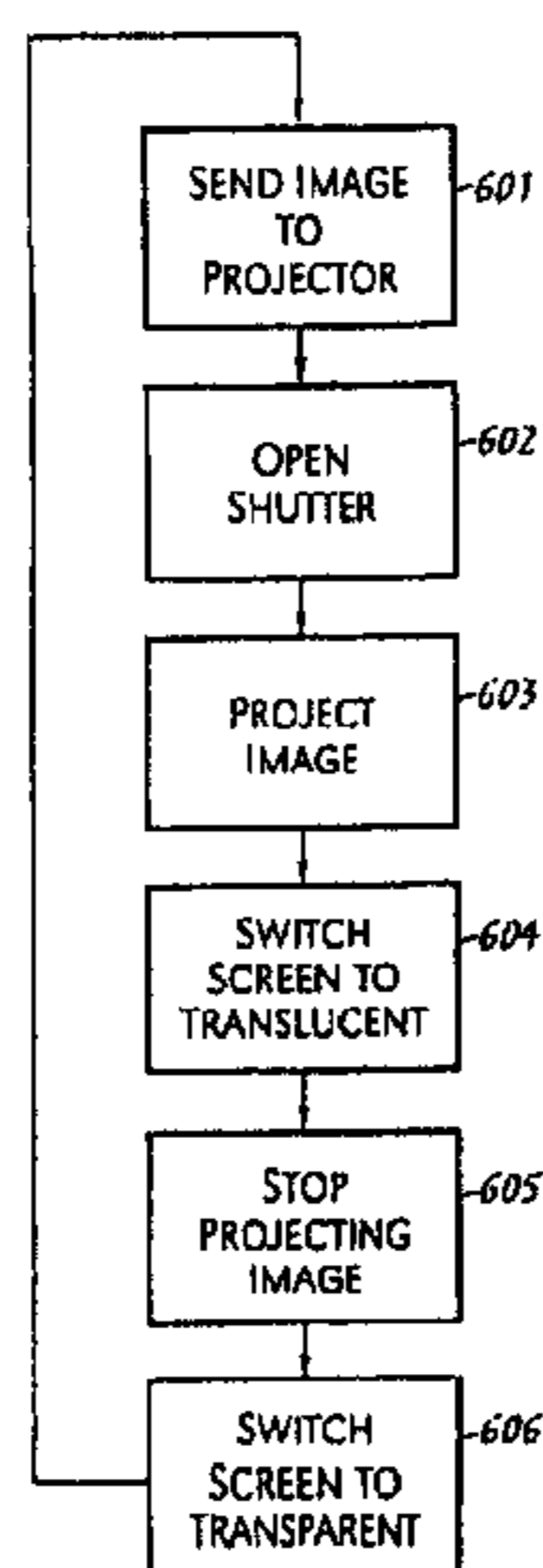

(Amended)

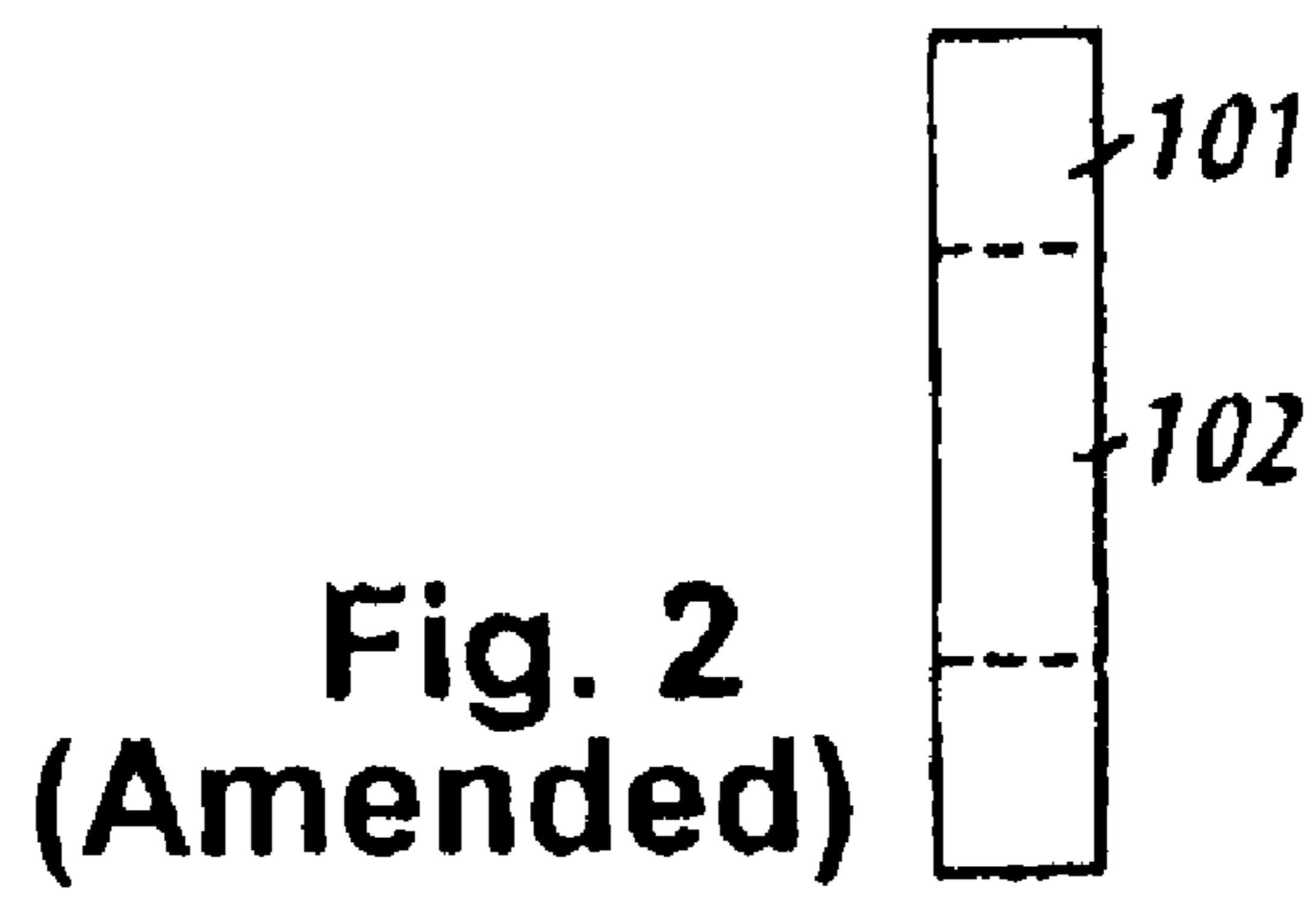
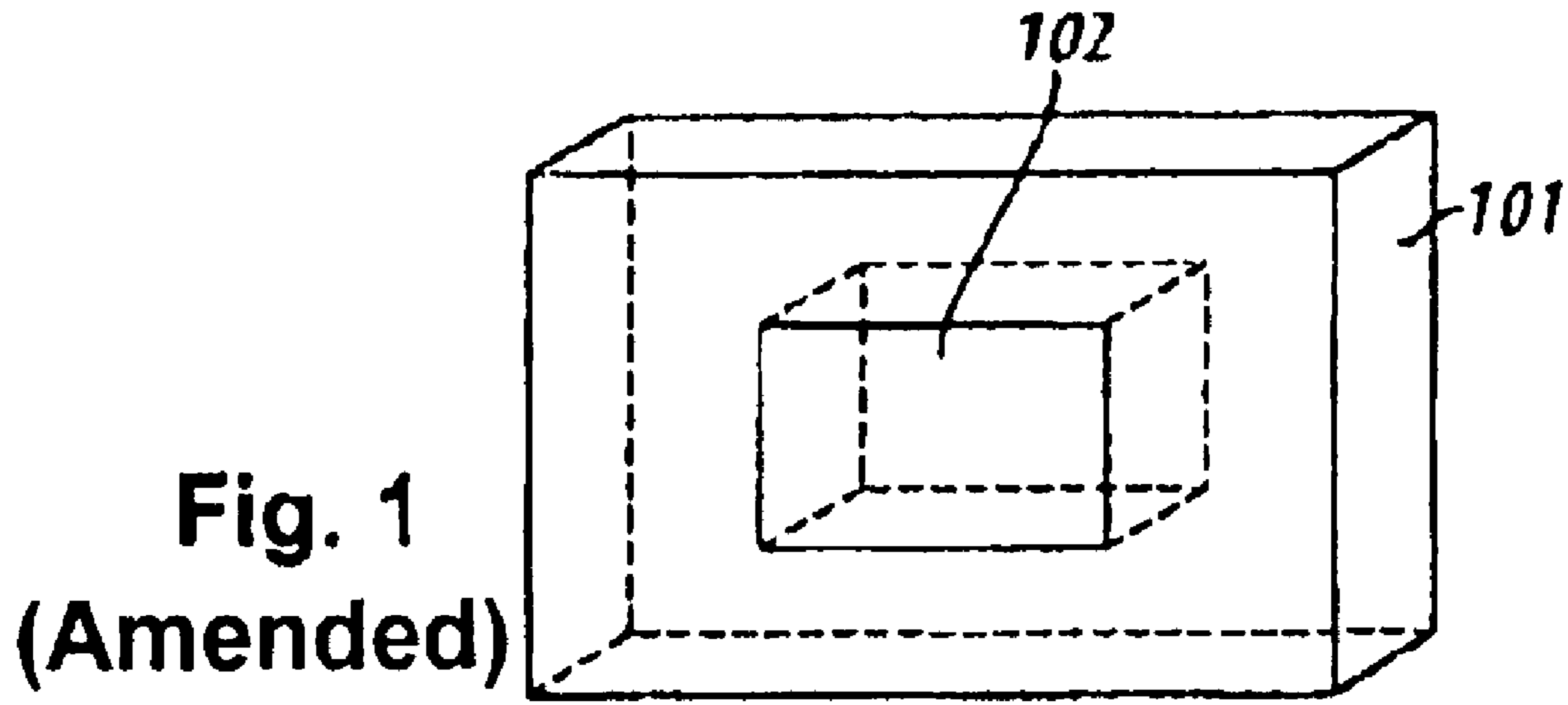

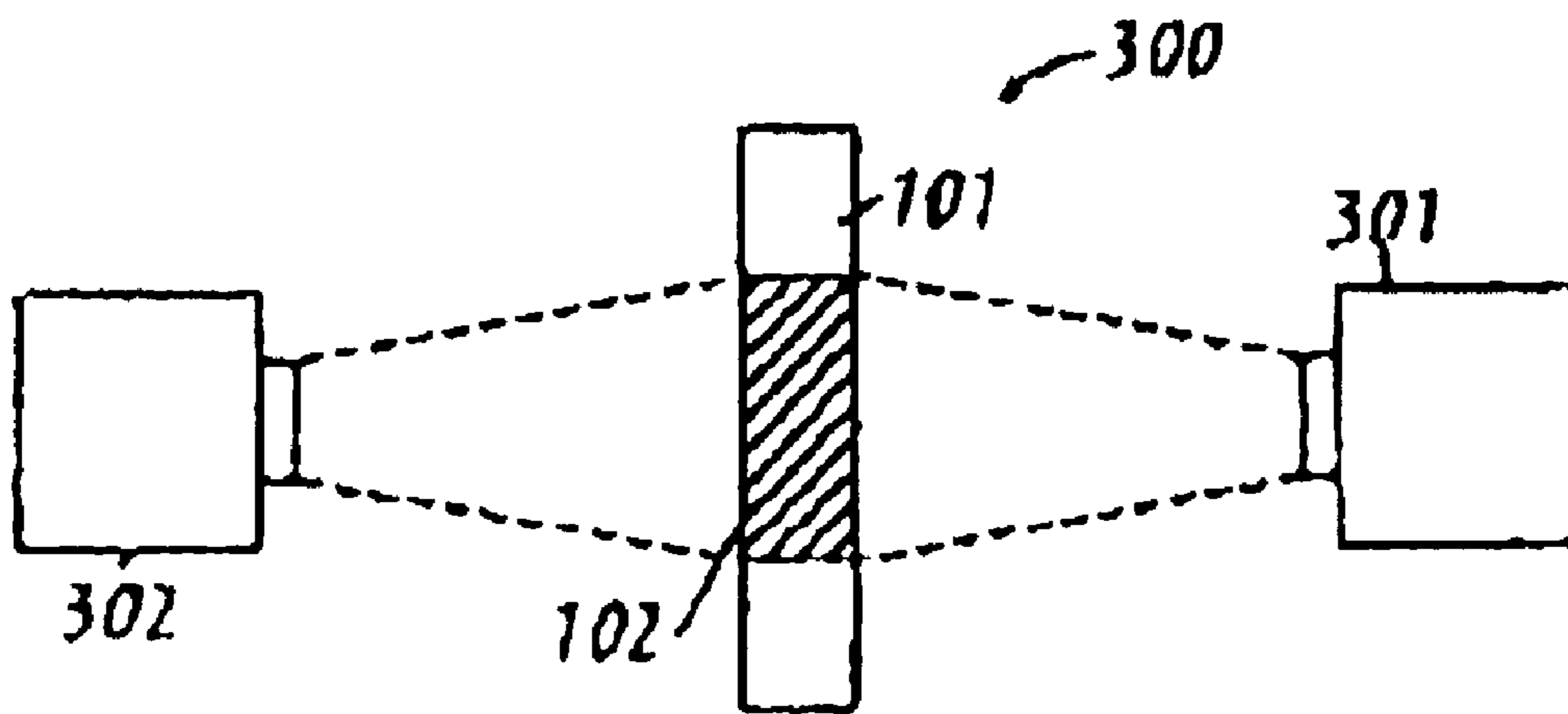

**Fig. 3**  
**(Amended)**

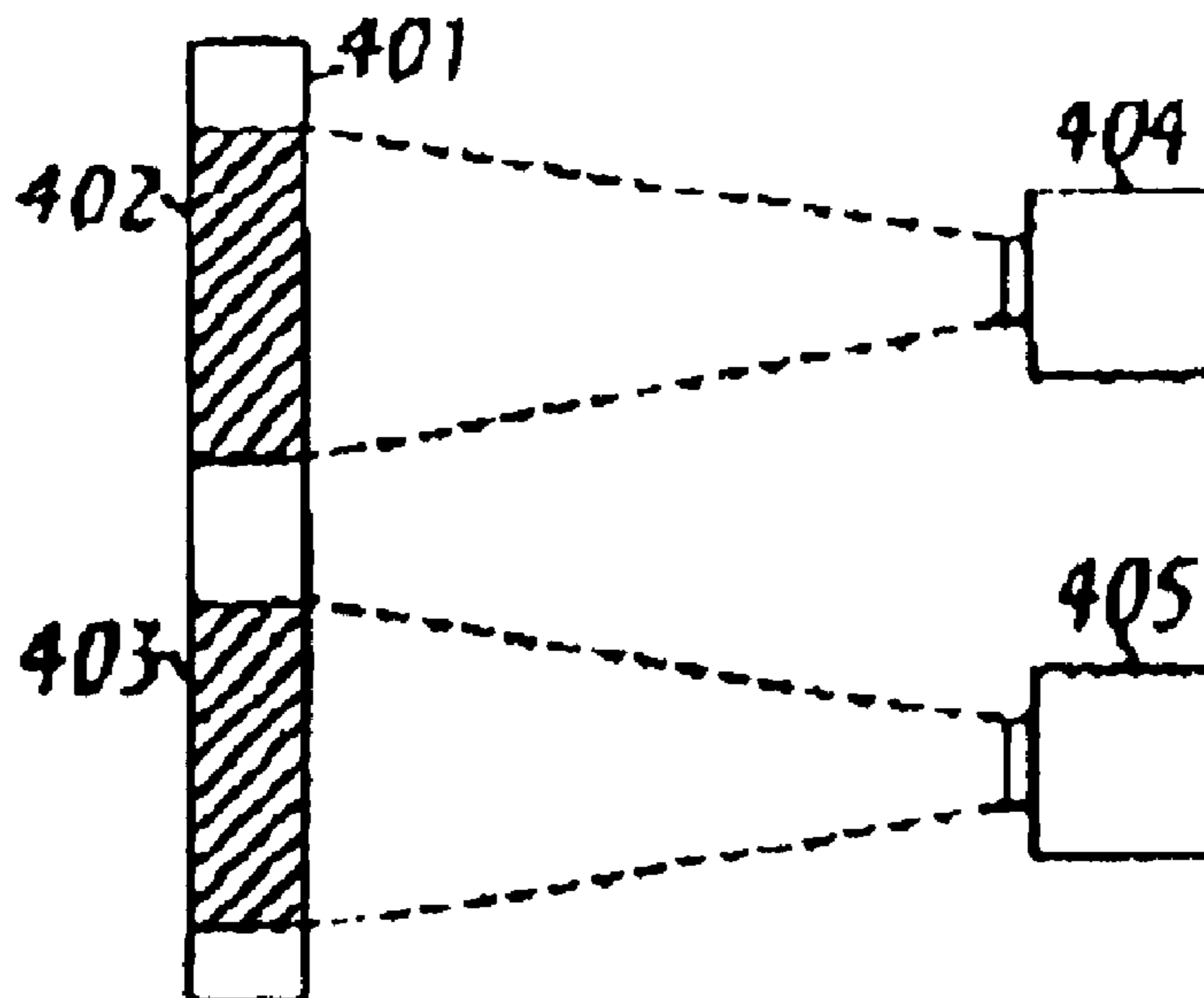

**Fig. 4**  
**(Amended)**

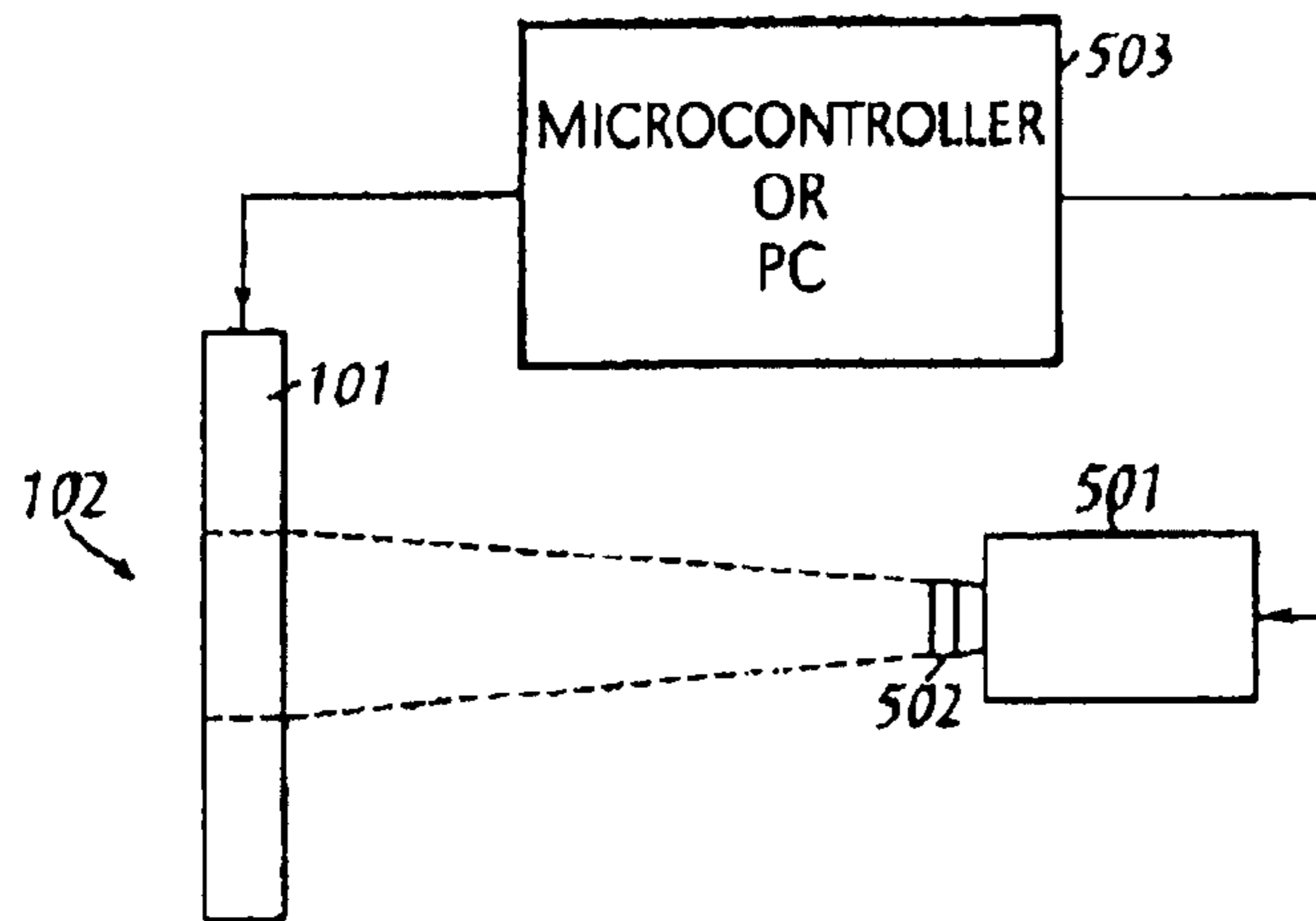

Fig. 5  
(Amended)

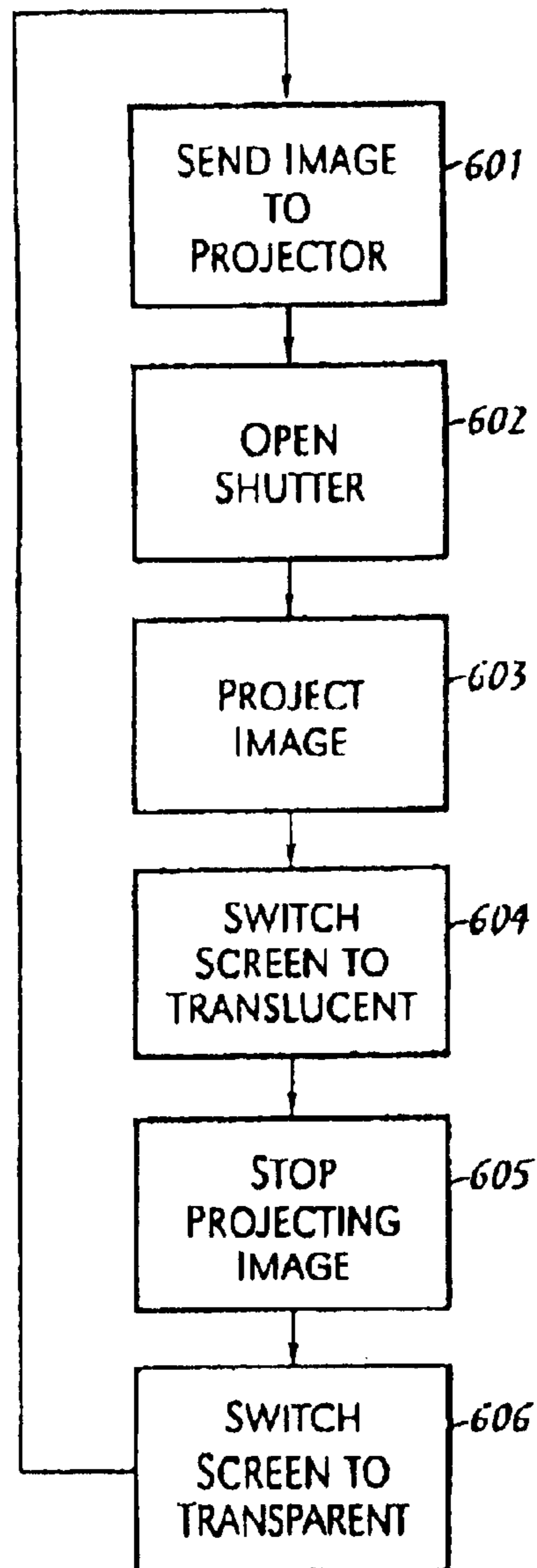
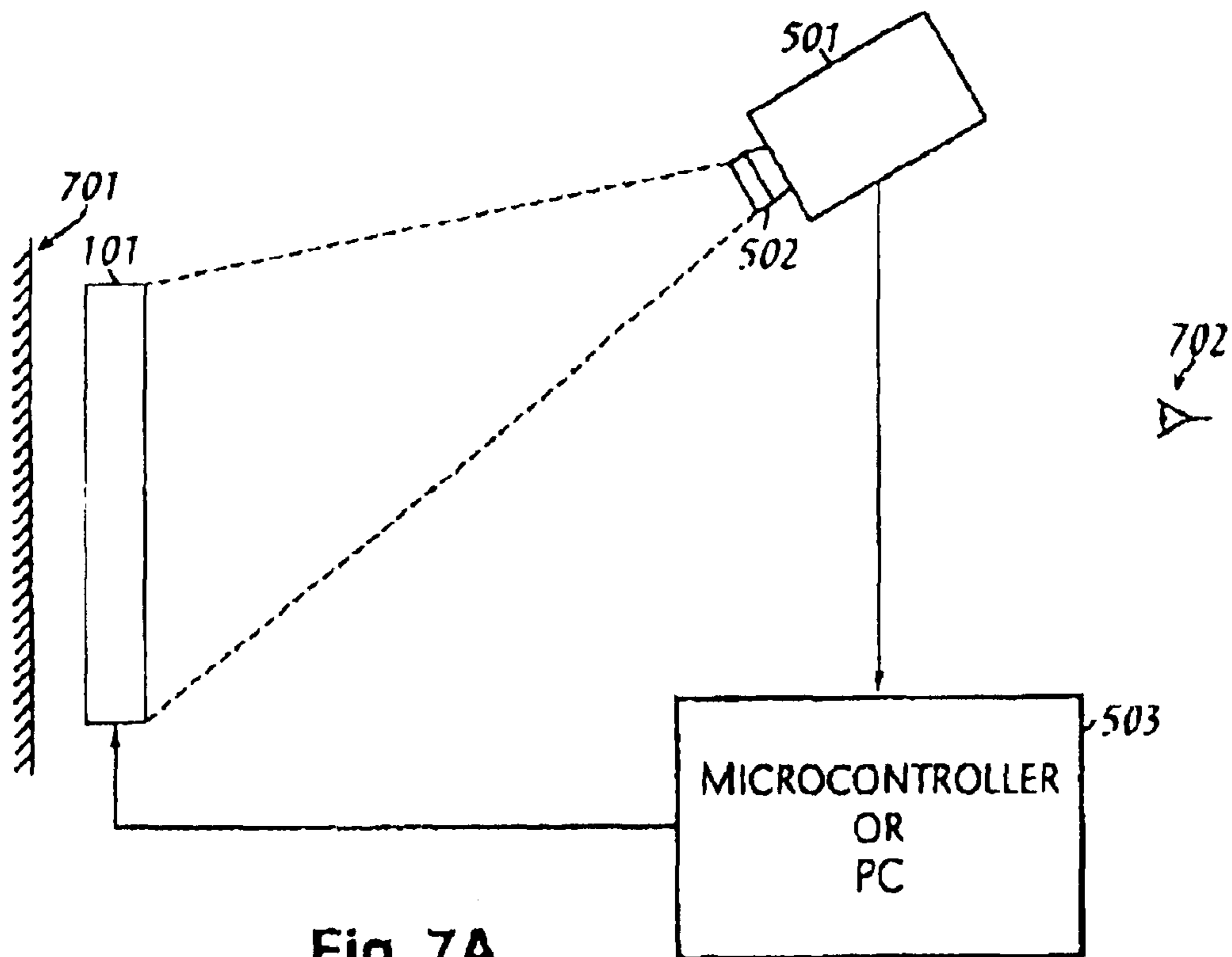
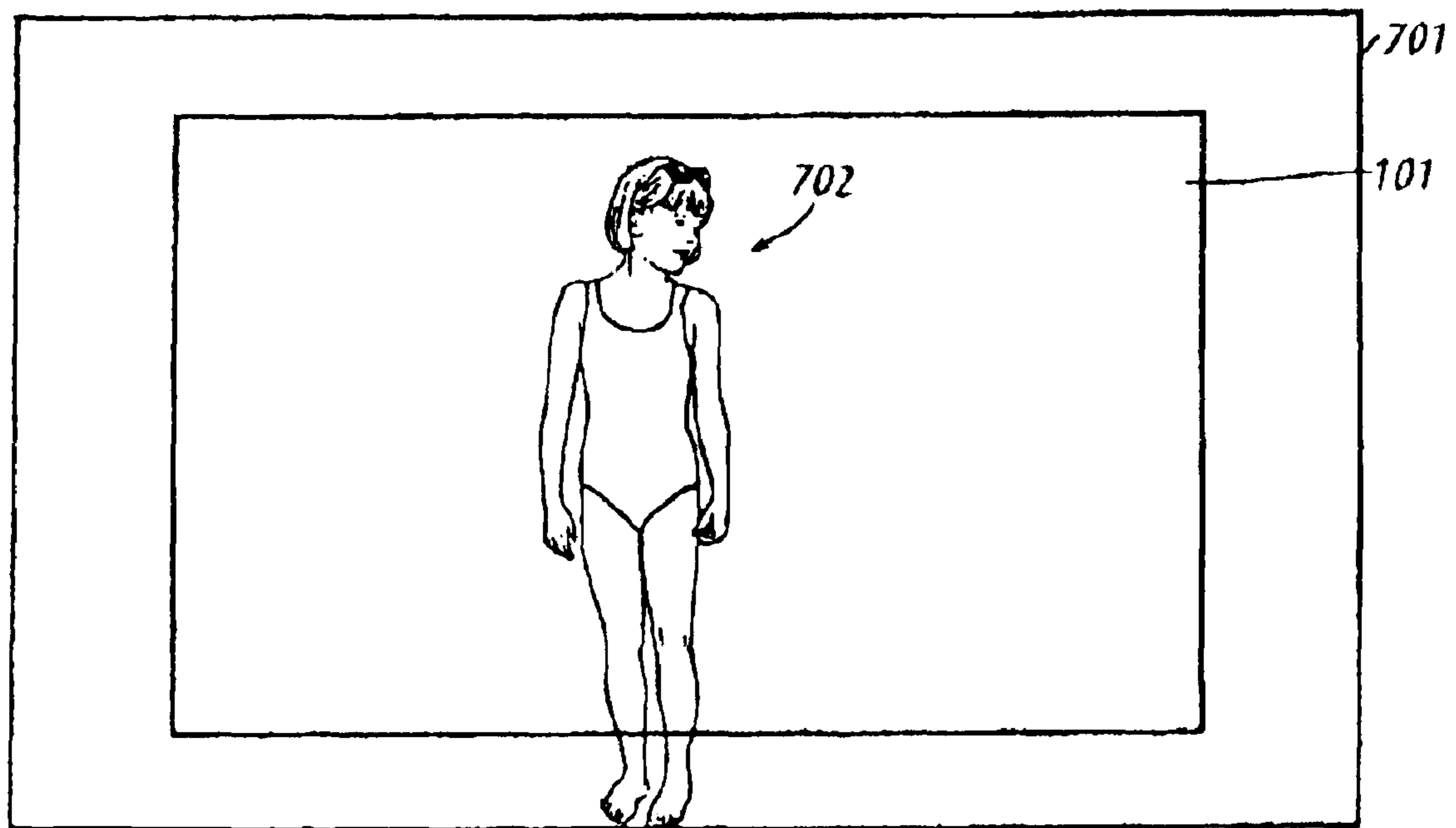

Fig. 6  
(Amended)



**Fig. 7A**  
**(Amended)**



**Fig. 7B**  
**(Amended)**

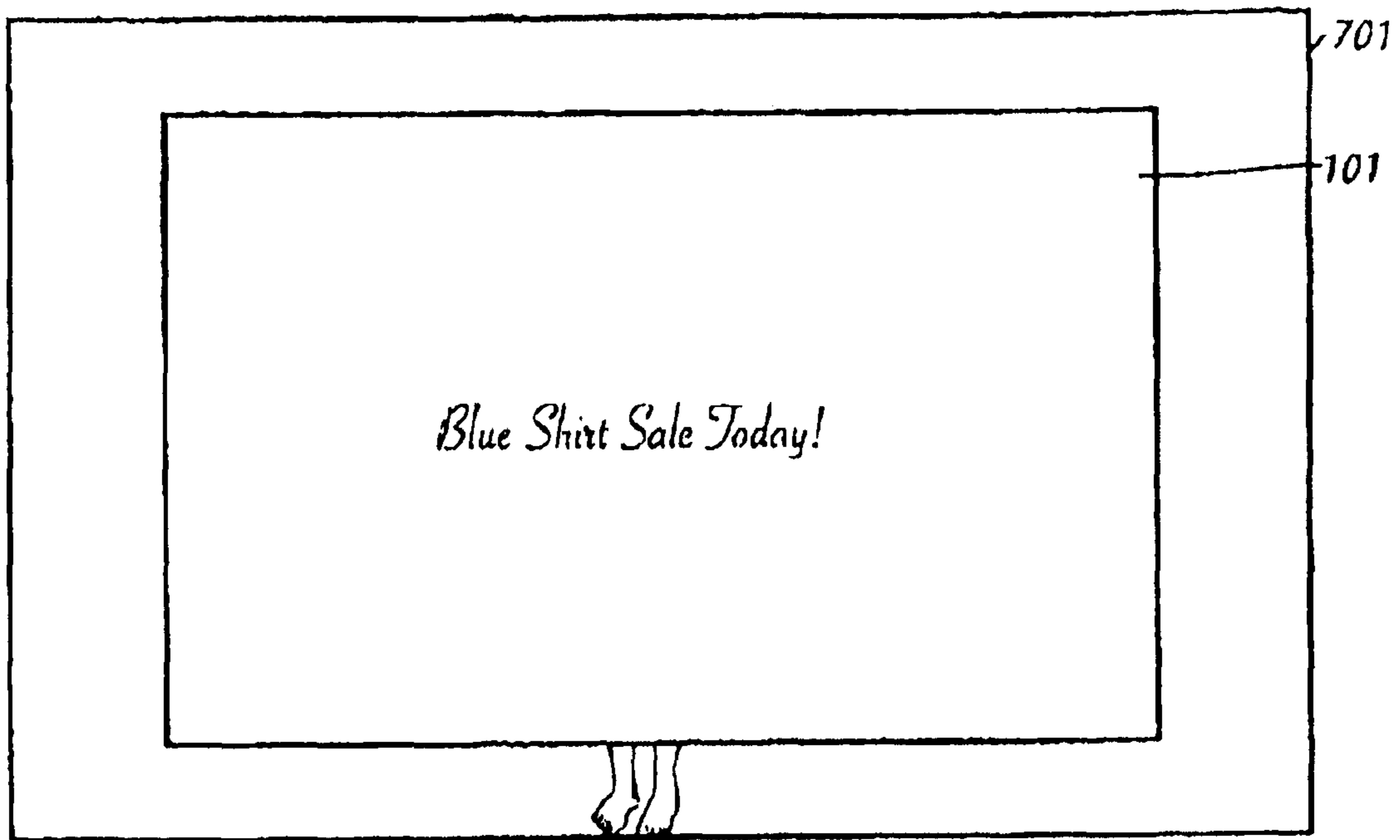

**Fig. 7C**  
**(Amended)**

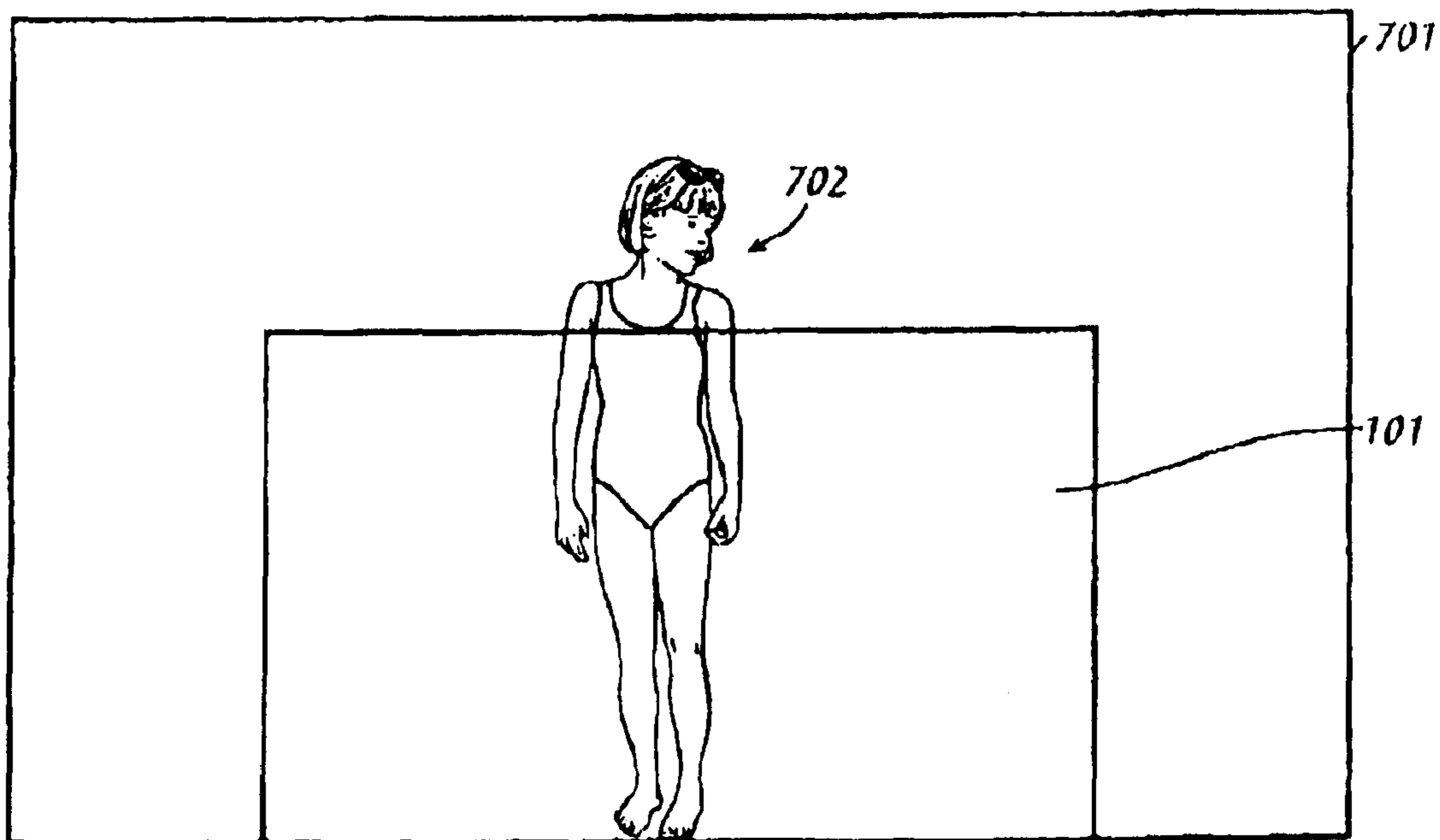

**Fig. 7D**  
**(Amended)**

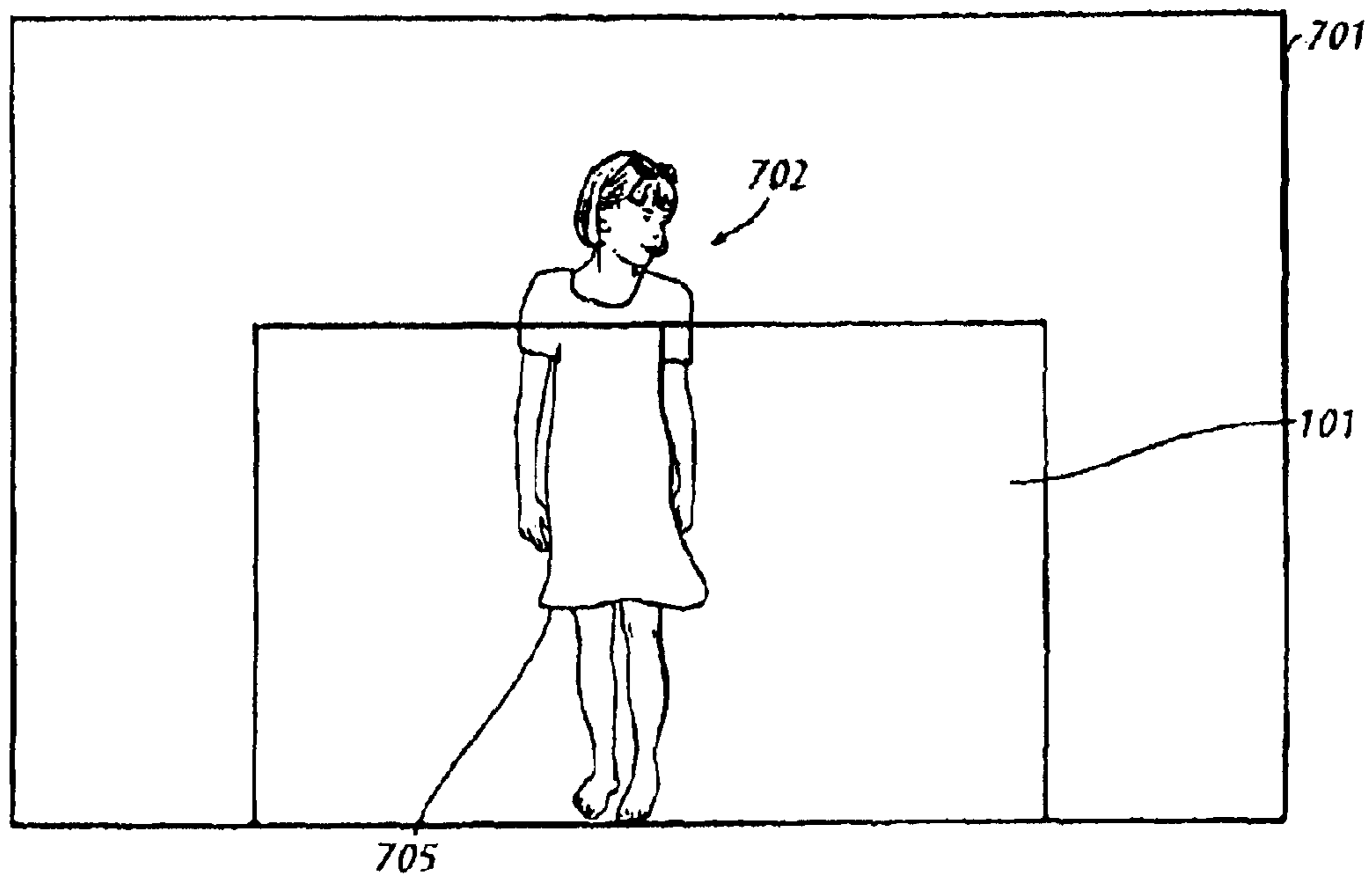

Fig. 7E  
(Amended)

## IMAGE PROJECTION SYSTEM

**Matter enclosed in heavy brackets [ ] appears in the original patent but forms no part of this reissue specification; matter printed in italics indicates the additions made by reissue.**

## CROSS-REFERENCE TO RELATED APPLICATION

The present application is a continuation-in-part of U.S. patent application Ser. No. 09/519,537 filed Mar. 6, 2000 now U.S. Pat. No. 6,577,355 entitled "Switchable Transparent Screens for Image Projection System."

## TECHNICAL FIELD

The present invention is generally related to the field of image projection systems.

## BACKGROUND INFORMATION

In U.S. patent application Ser. No. 09/519,537, an invention was disclosed whereby a substantially transparent medium could be used as a projection screen for capturing an image from an image projector. When the medium was not capturing an image from an image projector, its substantially transparent characteristic permitted persons to see through the medium. However, the system also provided an ability for the medium to capture an image from an image projector for viewing by persons. In one embodiment, the medium was made to have a characteristic that caused it to be nearly opaque, or substantially translucent (permitting the passage of light, but not sufficient as to be able to view objects clearly), so that persons could see clearly the image projected.

The present invention takes the advantages of this system to further user.

## BRIEF DESCRIPTION OF THE DRAWINGS

For a more complete understanding of the present invention, and the advantages thereof, reference is now made to the following descriptions taken in conjunction with the accompanying drawings, in which:

FIG. 1 illustrates a prospective view of a projection screen in accordance with the present invention,

FIG. 2 illustrates a side view of the projection screen shown in FIG. 1;

FIG. 3 is a side view of an image projection system;

FIG. 4 illustrates an alternative embodiment of the present invention;

FIG. 5 illustrates an embodiment of the present invention;

FIG. 6 illustrates a flow diagram of an embodiment of the present invention, and

FIGS. 7A-7E illustrate alternative embodiments of the present invention.

## DETAILED DESCRIPTION

In the following description, numerous specific details are set forth such as specific materials to provide a thorough understanding of the present invention. However, it will be obvious to those skilled in the art that the present invention may be practiced without such specific details. In other instances, well-known circuits have been shown in block diagram form in order not to obscure the present invention in unnecessary detail. For the most part, details concerning

timing considerations and the like have been omitted in as much as such details are not necessary to obtain a complete understanding of the present invention and are within the skills of persons of ordinary skill in the relevant art.

While the specification concludes with claims defining the features of the invention that are regarded as novel, it is believed that the invention will be better understood from a consideration of the following description in conjunction with the drawing figures, in which like reference numerals are carried forward.

Referring now to FIG. 3, there is illustrated therein a cross-sectional side view of the image projection system 300 as disclosed in U.S. patent application Ser. No. 09/519,537. The system 300 comprises a projector 301 of any type commonly used, examples of which include an LCD projector, a television projector currently used on conventional projection television systems, a film projector, a slide projector or a computer for providing computer generated images, to name but a few. The system 300 further includes a projection screen 101. However, the projection screen herein is a glass or other transparent (or semi-transparent) material, having one or more switchable portions. More particularly, the screen 101 may comprise a sheet of glass having a portion 102 or portions that can be switched between the glass' typical transparent characteristic, to a translucent appearance or condition. Projector 301 may project an image onto portion 102, which will be viewable by viewers on both sides of screen 101 when portion 102 is translucent, on the right side when it is opaque. Alternatively, when portion 102 is translucent or opaque, another projector 302 can be used to project an image onto the other side of screen 101 so that such an image is viewable by viewers on the left side of screen 101.

The invention is also applicable for projection on reflective surfaces such as mirrors.

As is readily apparent, light, as from a projected image, projected onto a sheet of glass or other transparent material leaves no readily viewable impression. This is due of course to the fact that the projected light passes substantially unimpeded through the glass. Accordingly, heretofore retail establishments, for example, having large areas of display glass windows were forced to post paper sign advertising, for example, as on-going sale. This type of advertising is neither dynamic, nor particularly effective. Conversely, an advertising scheme taking advantage of the projection system described herein has many advantages. In particular, by projecting an image onto the translucent area of the glass substrate, the projected image is visible by viewers on both sides of the glass. Moreover, while only a portion of the glass or other substrate may be switchable between the transparent and the translucent condition, the whole of the substrate may in fact be switchable. This allows a condition in which, for example, a glass pane becomes an entire wall of e.g., advertising area.

Referring now to FIGS. 1 and 2, the transparent screen 101 may be a glass panel such as a display window, or some other type of transparent medium. Examples of such transparent media include various types of plastics, cast or fabricated as plastic sheets. The switchable portion 102 switches between the transparent (or semi-transparent) state, which is unsuitable for the receipt of a projected image, to a translucent or opaque state which will readily receive a projected image.

The switchable portion 102 may be provided by equipping the transparent screen 101 with an electrical, chemical or photosensitive material which is transparent in the



absence of a stimulus, but switches to a translucent or opaque state upon receipt of a particular stimulus. Examples of electrochromic, photochromic, and electrophoretic materials which may be advantageously employed in this function are well known to those of ordinary skill in the art. For example, a polymer dispersed liquid crystal material as is commonly available may be sandwiched between sheets of glass or plastic in one or more portions of a transparent sheet. As oriented in the standard configuration, the molecules of liquid crystal material will allow for the passage of light therethrough, i.e., the portion is transparent. However, upon application of a relatively small electrical stimulus, the molecules of liquid crystal material may be made to change their orientation, thus taking on a translucent or nearly opaque appearance and making such area of the transparent sheet suitable for the receipt of a projected image. Such switchable materials are disclosed within J. W. Doane et al., *Displays from a New Type of Liquid Crystal Microdroplet Dispersion*, IEEE, 1985 International Display Research Conference, pp. 153–154 (1985); J. W. Doane et al., *Wide-Angle-View PDLC Displays*, SID 90 DIGEST, pp. 224–226 (1990); Z. Yaniv et al., *Active Matrix Polymer Dispersed Liquid Crystal Display*, JAPAN DISPLAY, pp. 572–575 (1989), which are all incorporated by reference herein.

Alternately, the medium 101 may be coated with a special resin called a photopolymer which is capable of refracting light in the manner of a prism. The screen is configured to polarize the incident light falling on different areas of the screen (angle of incidence at screen center may be 35°) so that it emerges from the front evenly to produce a bright and clear image with a high degree of uniformity. Thus, when the projector is off, light entering the medium in a substantially perpendicular manner will be allowed to pass through so that a person can see directly through the medium. However, if an image is projected at a specified angle to the medium, such as image is projected onto the medium for viewing. Such a projection system is available commercially from Hitachi.

While FIGS. 1, 2 and 3 illustrate but a single switchable portion 102 on the transparent sheet 101, it is to be understood that the invention is not so limited. For example, and as is illustrated in FIG. 4, a plurality of image projectors 404, 405 may be used to provide a plurality of projected images onto a plurality of switchable portions 402, 403 of a transparent sheet 401 or plural sheets. Such an embodiment would have great utility in, for example, retail settings.

In yet another embodiment, two or more portions may be arranged in an overlapping relationship. This overlapping relationship may be either a situation in which two portions directly overlay one another, or partially do so. If two overlay one another completely, such a configuration may be employed to allow images to be projected in differing light conditions. For example, the first portion may be a darker translucent portion for better image quality in a first set of light conditions, while the second portion may be a lighter translucent portion adapted for a second set of light conditions. Each of the portions would of course be independently controllable.

Referring to FIG. 5, there is illustrated a projection system in accordance with the present invention whereby an image projector 501 is projecting an image onto portion 102 of medium 101. A microcontroller or personal computer (PC) 503 may control what images are projected by projector 501, and may control a shutter 502 so that projector 501 can remain continuously on, without having to be turned on and off, and merely provide for the projection of the image out of the projector 501 in accordance with the algorithm as

described below with respect to FIG. 6. Simultaneously, when the shutter 502 is opened, the medium 101 can be made to have its portion 102 be translucent for receipt of the projected image.

FIG. 6 illustrates a flow diagram of this process. In step 601, microcontroller 503 will send an image to projector 501. In step 602, shutter 502 is opened. In step 603, the image is projected by projector 501. In step 604, substantially simultaneously with the opening of the shutter in step 602, the portion 102 is transformed to a translucent state for receipt of the projected image. At a later time, in step 605, the shutter 502 will be closed stopping projection of the image. Substantially simultaneously with step 605, portion 102 of screen 101 will be switched to a transparent state.

Referring to FIG. 7A, there is illustrated an alternative embodiment of the present invention where screen 101 is placed in front of a mirror 701 shown in side view. As a result, when screen 101 is in a transparent state, viewer 702 will see a reflection of the viewer. When screen 101 is placed in a translucent state and shutter 502 is opened to allow projection of an image from projector 501, viewer 702 will see the projected image onto screen 101.

As an example, referring to FIG. 7B, there is shown a front view of the system in FIG. 7A where a viewer 702 sees himself/herself through the transparent screen 101 within the mirror 701. FIG. 7C illustrates the system when an image is projected onto screen 101 so that viewer 702 now sees the projected image.

FIGS. 7D and 7E illustrate an alternative embodiment of the present invention where screen 101 is positioned in front of mirror 701 so that when the screen 101 is in a transparent state, with no image being projected, the viewer 702 sees himself/herself in mirror 701. FIG. 7E illustrates the projection of a clothing article, such as a dress 705, projected onto screen 101 so that viewer 702, who sees himself/herself partially in mirror 701, can view himself/herself in a virtual image with the dress.

Alternatively, a film implementing the properties of screen 101 could be attached directly onto the glass surface of the mirror.

Furthermore, screen 101 could be positioned so that it is incognito and thus does not present an image to be reflected in mirror 701. Then, when an image is projected onto screen 101 (maybe in reverse), it will be reflected by mirror 701, and viewed by persons.

Although the present invention and its advantages have been described in detail, it should be understood that various changes, substitutions and alterations can be made herein without departing from the spirit and scope of the invention as defined by the appended claims.

What is claimed is:

1. An image projection system comprising:

a screen;

a projector for projecting an image; and

a shutter for permitting passage of the image from the projector to the screen, wherein the screen is configured to allow an object to be viewed through the screen when the shutter is closed, and wherein the screen is configured to reflect the image projected from the projector when the shutter is open in substantially a manner so that the reflected image is primarily viewed as opposed to the object.

2. The system as recited in claim 1, wherein the screen further comprises a material that reflects the image when it is projected at an angle relative to the screen.

5

3. The system as recited in claim 1, wherein the screen further comprises a material that is substantially transparent when the screen is configured to allow the object to be viewed through the screen, and wherein the material is substantially translucent when the image is projected upon it.

4. A method for projecting an image comprising the steps of

delivering an image to a projector,

opening a shutter on the projector so that the image is projected from the projector onto a screen;

modifying a characteristic of the screen so that the projected image is substantially reflected by the screen;

closing the shutter on the projector so that the image is no longer projected from the projector onto the screen; and

modifying the characteristic of the screen so that the screen is substantially transparent.

5. The method as recited in claim 4, wherein the step of modifying the characteristic of the screen so that the projected image is substantially reflected by the screen causes the screen to be substantially translucent.

**[6. An image projection system comprising:**

a screen controllable between a first state of being substantially transparent and a second state of being substantially translucent;

a projector;

a mirror, wherein the screen is positioned near the mirror; circuitry for placing the screen in the first state;

circuitry for placing the screen in the second state; and

circuitry for projecting an image from the projector onto the screen when it is in the second state so that a person views the image reflected from the screen, wherein the screen is positioned so that when it is in the second state, the person can still view a portion of their reflection in the mirror.]

**[7. An image projection system comprising:**

a screen controllable between a first state of being substantially transparent and a second state of being substantially translucent;

a projector;

a mirror, wherein the screen is positioned near the mirror; circuitry for placing the screen in the first state;

circuitry for placing the screen in the second state;

circuitry for projecting an image from the projector onto the screen when it is in the second state so that a person views the image reflected from the screen; and

a controller for controlling the projector, projecting circuitry and placing circuitries in a manner so that the image is projected from the projector substantially simultaneously when the screen is switched from the first state to the second state.]

**[8. The system as recited in claim 7, wherein the controller controls the projector, projecting circuitry and placing circuitries in a manner so that the image is not projected from the projector substantially simultaneously when the screen is switched from the second state to the first state.]**

**[9. The system as recited in claim 6, wherein when the screen is placed in the first state, the person can view their reflection in the mirror through the screen.]**

10. An image projection system comprising an image projecting means and an image receipt screen, said screen comprising a substantially transparent medium having a plurality of switchable portions, wherein each of the switchable portions is switchable between a substantially transparent optical characteristic and a substantially translucent optical

6

characteristic, wherein an image projected from the image projecting means is viewable on a first switchable portion of the plurality of switchable portions when the first switchable portion is switched to the substantially translucent optical characteristic, wherein no image projected from the image projecting means is viewable on the first switchable portion of the plurality of switchable portions when the first switchable portion is switched to the substantially transparent optical characteristic.

11. The image projection system as in claim 10, wherein substantially all of said transparent medium is switchable.

12. The image projection system as in claim 10, wherein said transparent medium is glass.

13. The image projection system as in claim 10, wherein said transparent medium is plastic.

14. The image projection system as in claim 10, further comprising a plurality of image projecting means for projecting a plurality of images onto the plurality of switchable portions.

15. The image projection system as in claim 14, wherein said plurality of switchable portions are co-located on a single transparent medium.

16. The image projection system as in claim 10, wherein said system is used in a video image projection system.

17. The image projection system as in claim 10, wherein said system is used in a television image projection system.

18. The image projection system as in claim 10, wherein said system is used in a computer-generated image projection system.

19. The image projection system as in claim 10, wherein the plurality of switchable portions comprise at least first and second independently switchable portions disposed adjacent one another.

20. The image projection system as in claim 19, wherein said first and second independently switchable portions are each adapted for a different lighting condition.

21. The image projection system as in claim 19, wherein said first and second portions are at least partially overlapping.

22. An image projection system comprising:  
an image projector;

an image receipt screen for displaying images projected by the image projector, said image receipt screen comprising a substantially transparent medium having at least one portion switchable between a substantially transparent optical characteristic and a substantially translucent optical characteristic, wherein an image projected by the image projector is not viewable on the at least one switchable portion of the image receipt screen when the at least one switchable portion is switched to the substantially transparent optical characteristic, wherein the image receipt screen has a first side and a second side; and

a reflective device, wherein the image receipt screen and reflective device are positioned and configured to permit a user facing the first side of the image receipt screen to see at least a portion of the user's reflection in the reflective device when the at least one portion is switched to the substantially translucent optical characteristic.

23. An image projection system comprising:

a screen, wherein the screen comprises a first switchable portion and a second switchable portion, wherein the first and second switchable portions are independently switchable between a first state and a second state, wherein the first state is substantially transparent and the second state is substantially translucent;

one or more projectors for projecting an image;

at least one shutter for permitting passage of the image from at least one of the one or more projectors to the screen, wherein the screen is configured to allow an object to be viewed through the screen when the at least one shutter is closed and when the first or second portion of the screen is switched to the first state, and wherein the first or second portion of the screen is configured to display the image projected from at least one of the one or more projectors when the at least one shutter is open and when the first or second portion of the screen is switched to the second state in substantially a manner so that the displayed image is primarily viewed as opposed to the object.

24. The system as recited in claim 23, wherein the screen further comprises a material that displays the image when it is projected at an angle relative to the screen.

25. The system as recited in claim 23, wherein the screen further comprises a material that is substantially transparent when the screen is configured to allow the object to be viewed through the screen, and wherein the material is substantially translucent when the image is projected upon it.

26. A method for projecting an image comprising the steps of:

delivering an image to one or more projectors;

opening a shutter on at least one of the one or more projectors so that a first image is projected from the at least one of the one or more projectors onto a screen;

modifying a characteristic of a first portion of the screen so that the first image is displayed by the first portion of the screen;

modifying a characteristic of a second portion of the screen so that the second portion of the screen is substantially transparent;

closing the shutter on the at least one of the one or more projectors so that the first image is no longer projected from the at least one of the one or more projectors onto the screen;

modifying the characteristic of the first portion of the screen so that the first portion of the screen is substantially transparent;

opening the shutter on at least one of the one or more projectors so that a second image is projected from the at least one of the one or more projectors onto the screen; and

modifying the characteristic of the second portion of the screen so that the second image is displayed by the second portion of the screen.

27. The method as recited in claim 26, wherein the step of modifying the characteristic of the first portion of the screen so that the first image is displayed by the first portion of the screen causes the first portion of the screen to be substantially translucent.

28. An image projection system comprising:

a screen controllable between a first state of being substantially transparent and a second state of being substantially translucent;

a projector;

a mirror, wherein the screen is positioned near the mirror;

circuitry for placing the screen in the first state;

circuitry for placing the screen in the second state; and

circuitry for projecting an image from the projector onto the screen when it is in the second state so that a person views the image displayed on the screen, wherein the screen is positioned so that when it is in the second state, the person can still view a portion of their reflection in the mirror.

29. An image projection system comprising:

a screen controllable between a first state of being substantially transparent and a second state of being substantially translucent;

a projector;

a mirror, wherein the screen is positioned near the mirror, wherein the screen is positioned between the projector and the mirror;

circuitry for placing the screen in the first state;

circuitry for placing the screen in the second state;

circuitry for projecting an image from the projector onto the screen when it is in the second state so that a person views the image displayed on the screen; and

a controller for controlling the projector, projecting circuitry and placing circuitries in a manner so that the image is projected from the projector substantially simultaneously when the screen is switched from the first state to the second state.

30. The system as recited in claim 29, wherein the controller controls the projector, projecting circuitry and placing circuitries in a manner so that the image is not projected from the projector substantially simultaneously when the screen is switched from the second state to the first state.

31. The system as recited in claim 28, wherein when the screen is placed in the first state, the person can view their reflection in the mirror through the screen.

\* \* \* \* \*