

US00RE41044E

(19) **United States**
(12) **Reissued Patent**
Hung

(10) **Patent Number:** **US RE41,044 E**
(45) **Date of Reissued Patent:** **Dec. 15, 2009**

(54) **CONNECTOR CAPABLE OF CONNECTING TO COAXIAL CABLE WITHOUT USING TOOL**

6,425,782 B1 * 7/2002 Holland 439/585
6,575,784 B1 * 6/2003 Yamada 439/578
6,634,906 B1 * 10/2003 Yeh 439/585
6,767,248 B1 * 7/2004 Hung 439/578
6,776,657 B1 * 8/2004 Hung 439/578

(75) Inventor: **Chen-Hung Hung**, Chia-Yi Hsien (TW)

(73) Assignee: **Ezconn Corporation**, Taipei (TW)

* cited by examiner

(21) Appl. No.: **11/392,921**

(22) Filed: **Mar. 30, 2006**

Primary Examiner—**Thanh-Tam T Le**

(74) *Attorney, Agent, or Firm*—**Rosenberg, Klein & Lee**

Related U.S. Patent Documents

Reissue of:

(64) Patent No.: **6,776,657**
Issued: **Aug. 17, 2004**
Appl. No.: **10/705,987**
Filed: **Nov. 13, 2003**

(51) **Int. Cl.**
H01R 9/05 (2006.01)

(52) **U.S. Cl.** **439/578**; 439/439

(58) **Field of Classification Search** 439/394,
439/439, 441, 578

See application file for complete search history.

(56) **References Cited**

U.S. PATENT DOCUMENTS

5,769,662 A * 6/1998 Stabile et al. 439/578

(57) **ABSTRACT**

Connector connectable to coaxial cable without using tool is disclosed. The connector comprises an outer sleeve including a front inward rim and a staged bore; an inner sleeve including a front flange and a front inward rim; a nut; a cylindrical coupling sleeved on the outer sleeve; and a resilient gripping ring. A rear inward rim of the nut is fitted between the outer sleeve and the flange and is sleeved on the inner sleeve. The rim of the outer sleeve is sleeved on the inner sleeve. The ring is sandwiched between a rear inward rim of the coupling and the inner sleeve. The cable is inserted into the coupling and the ring for fitting the outer insulator in the inner sleeve. The insertion is stopped as the outer insulator of the cable contacts the rim of the inner sleeve. The cable is fastened in the connector by the ring.

4 Claims, 6 Drawing Sheets

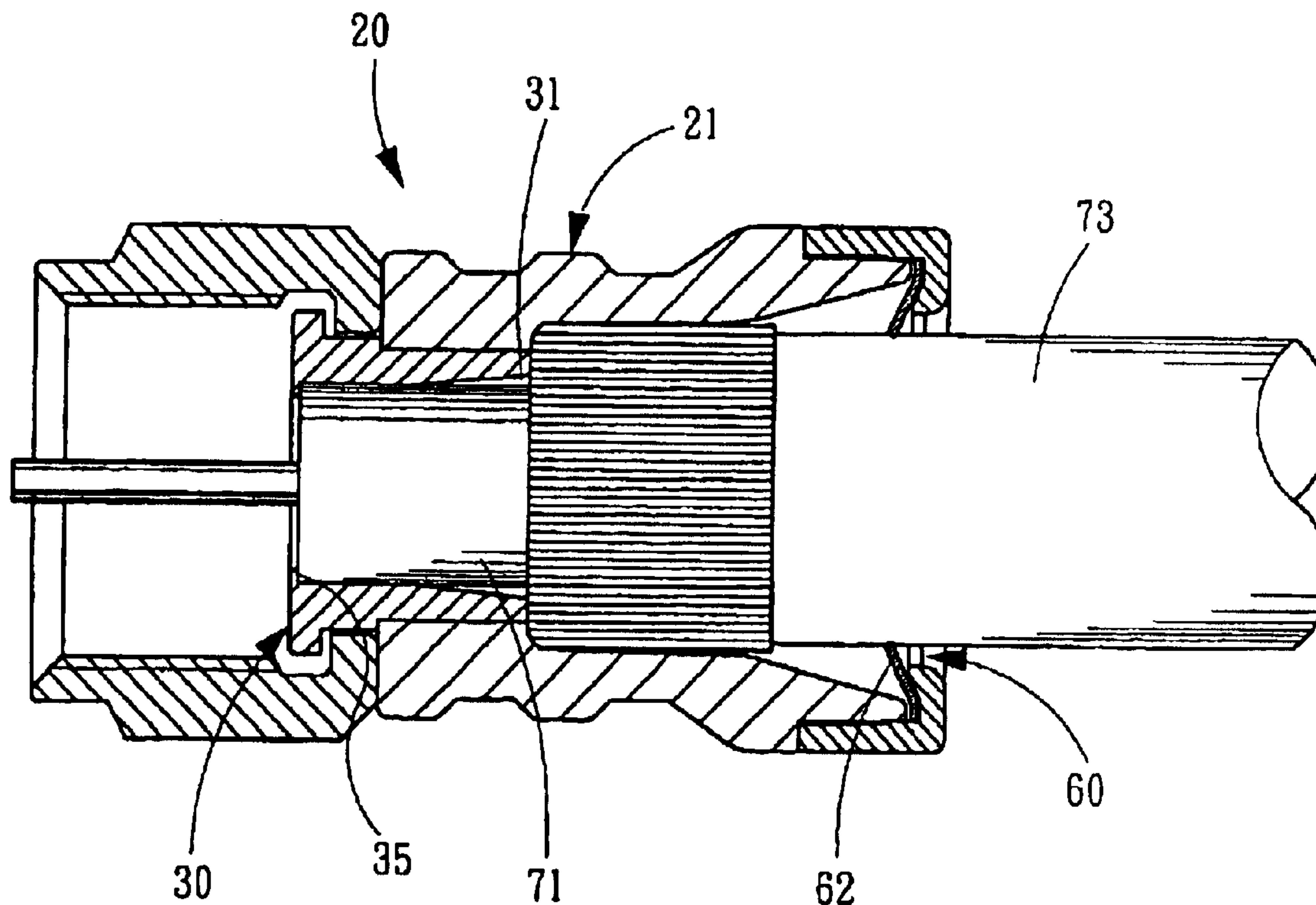

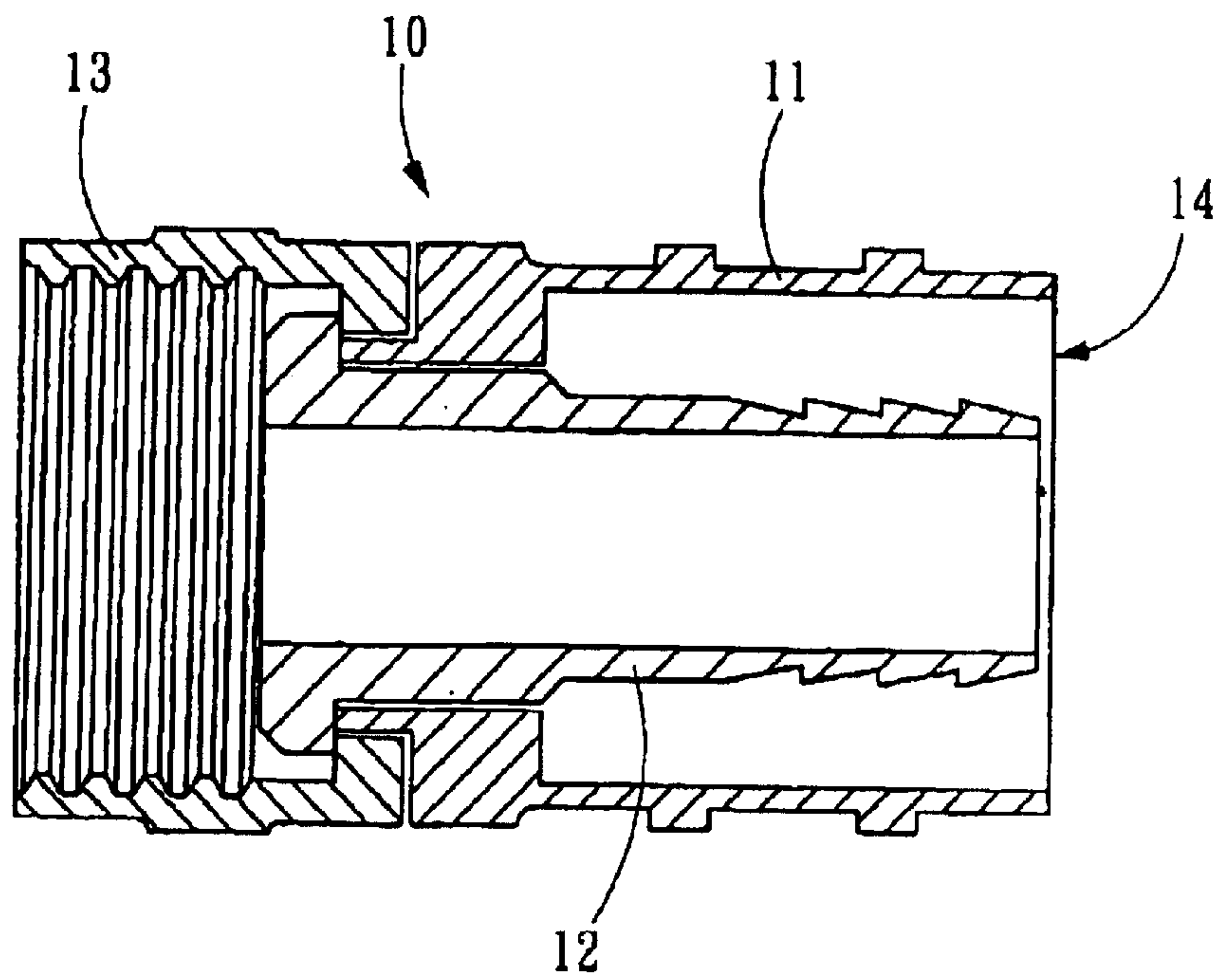

FIG.1A
PRIOR ART

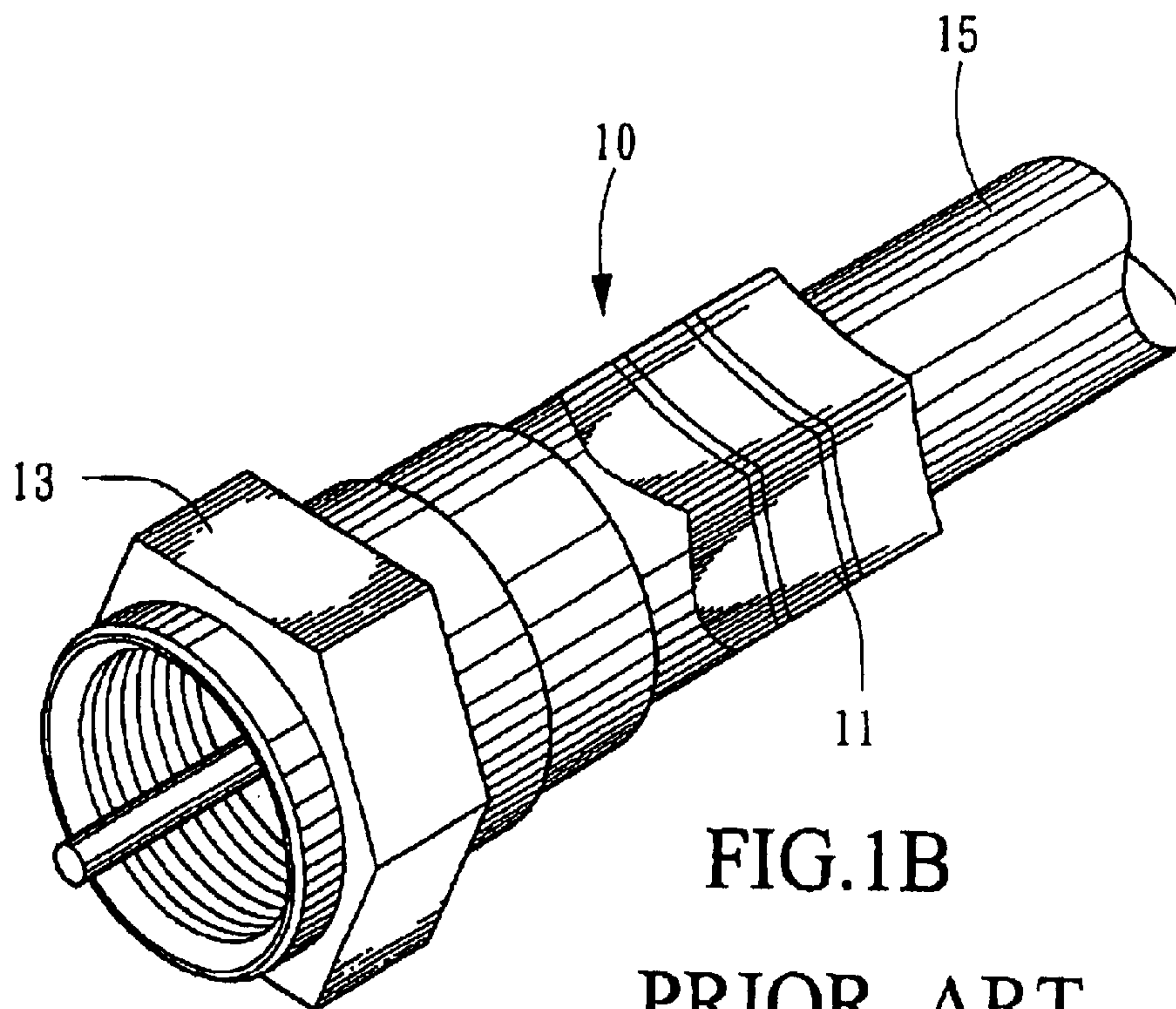

FIG.1B
PRIOR ART

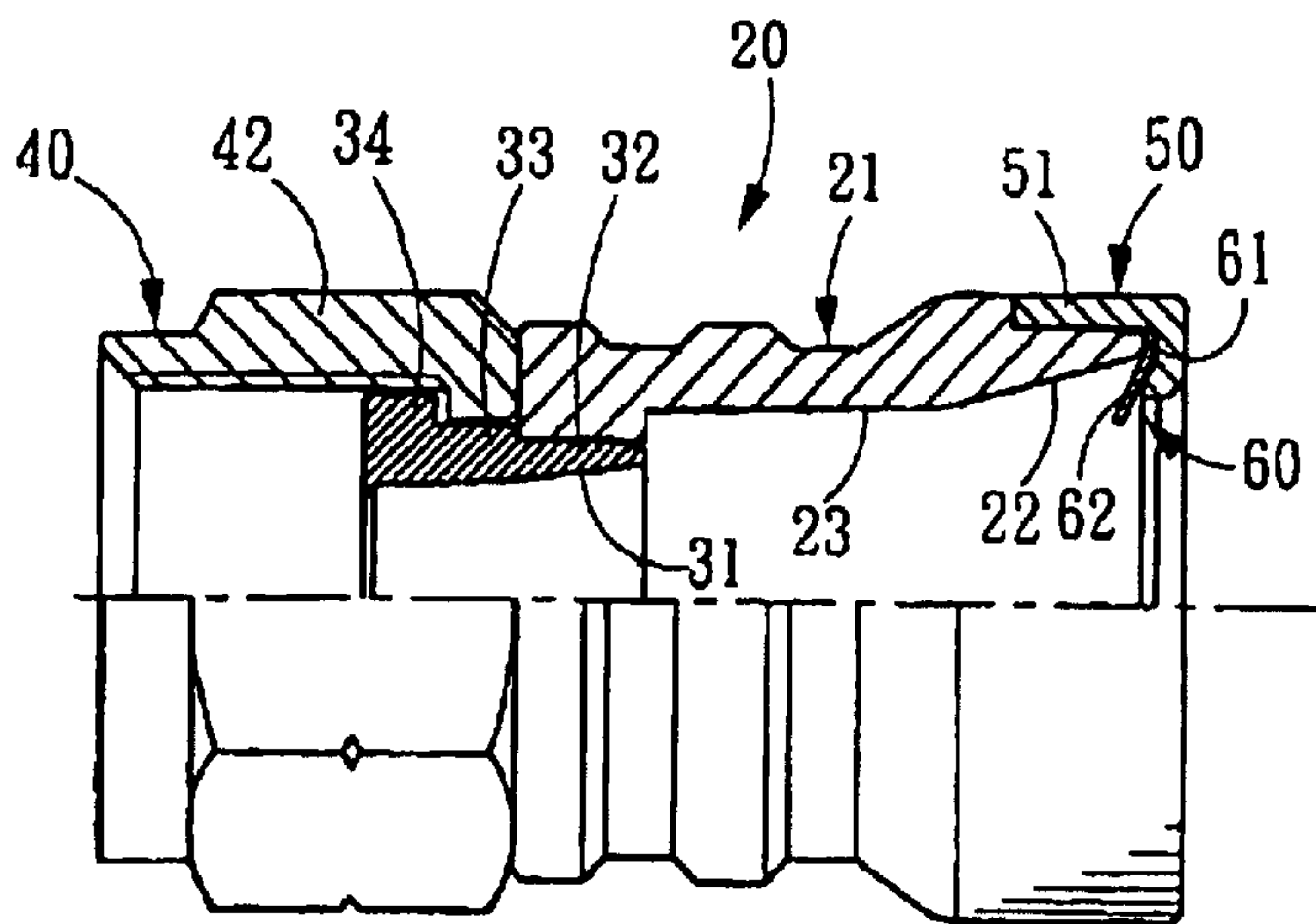

FIG. 2A

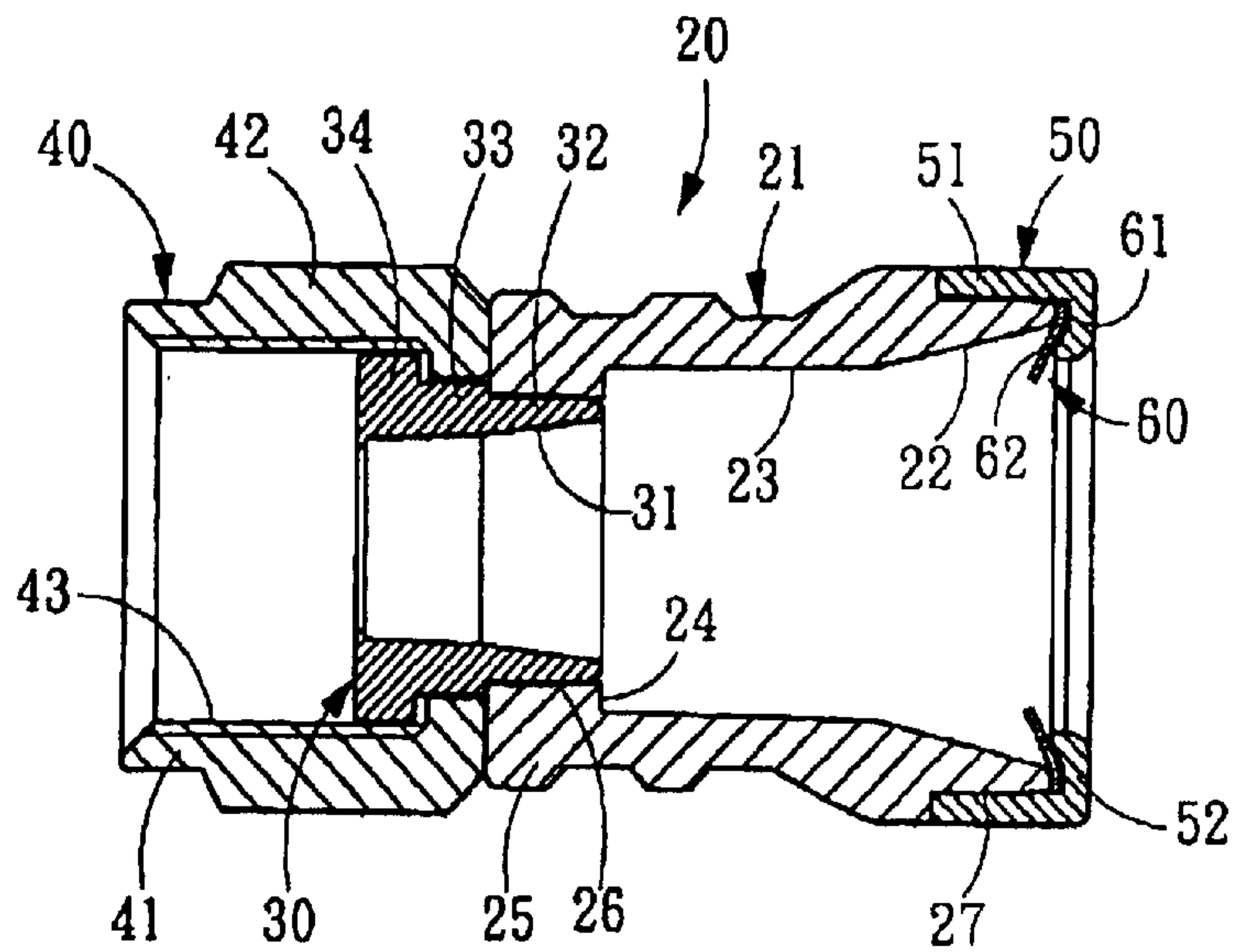

FIG. 2B

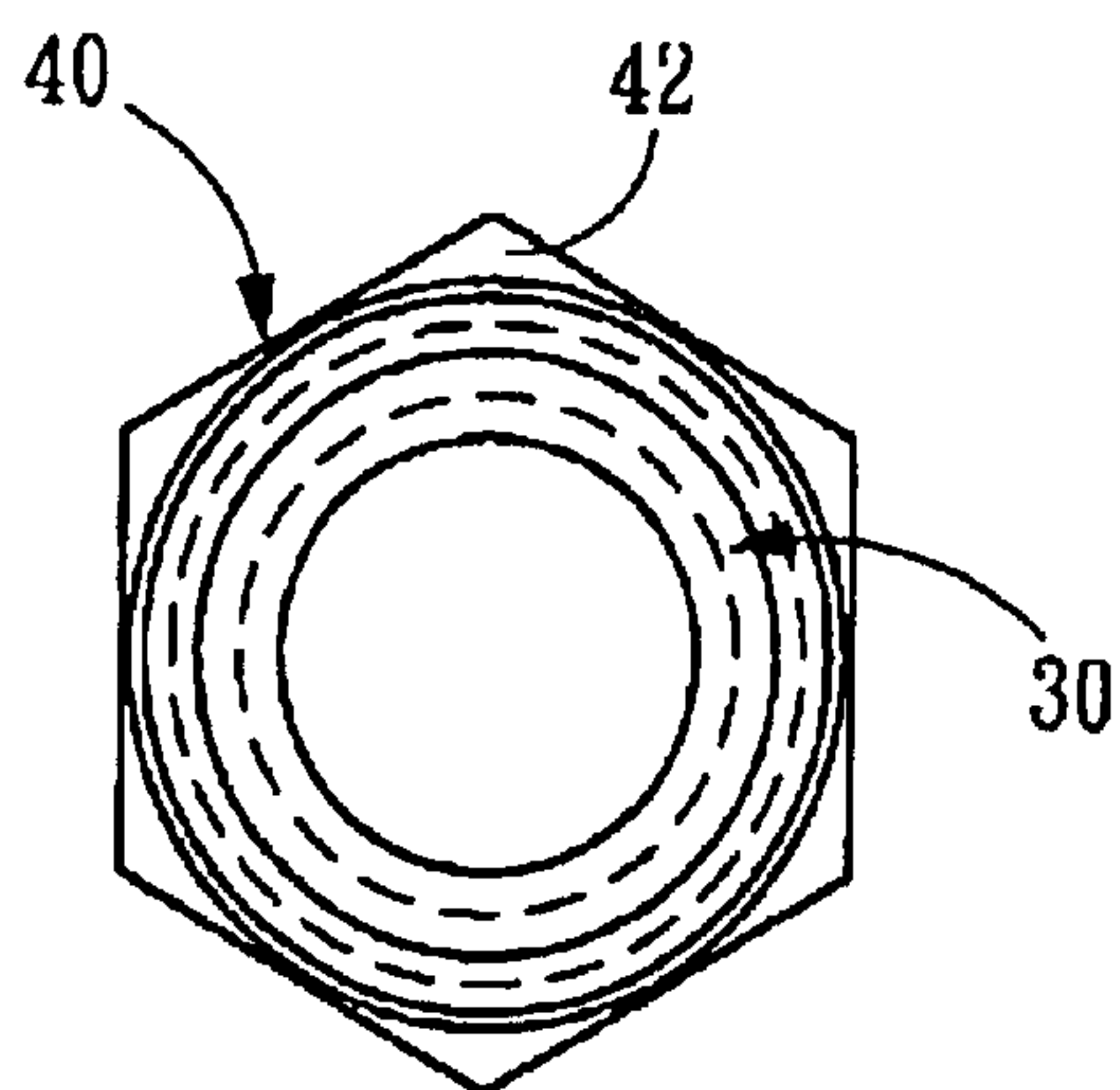

FIG. 2C

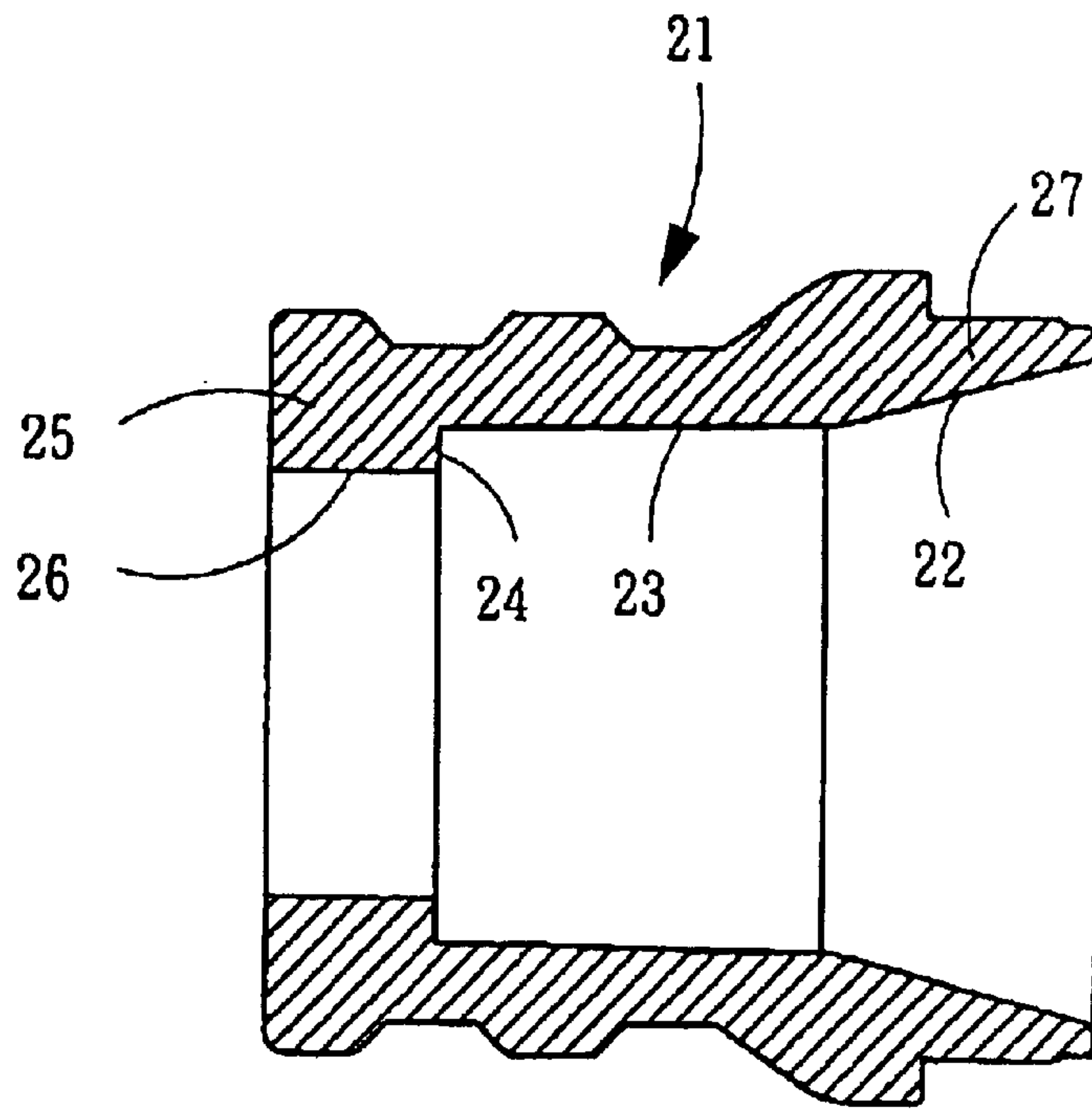

FIG. 3

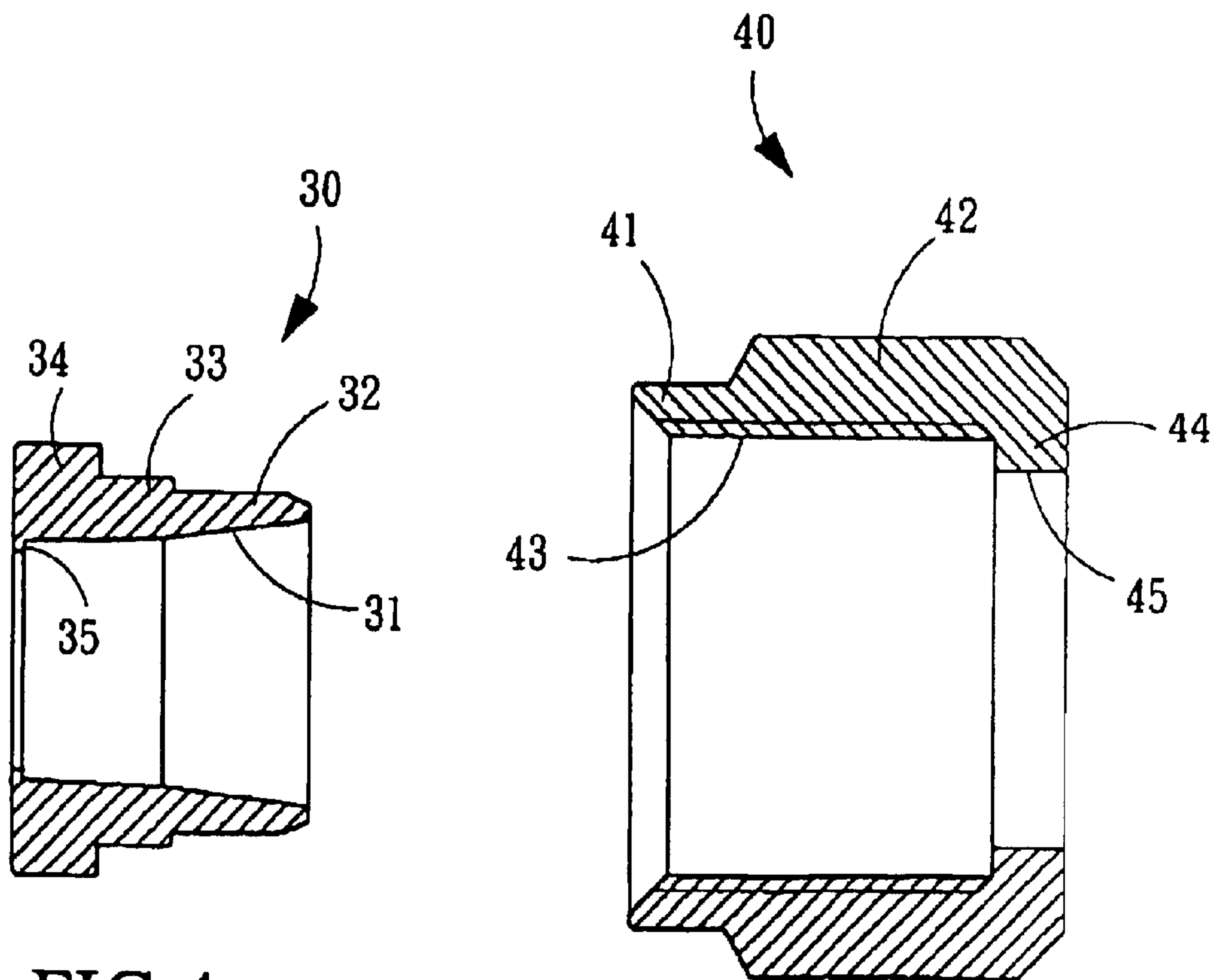

FIG. 4

FIG. 5

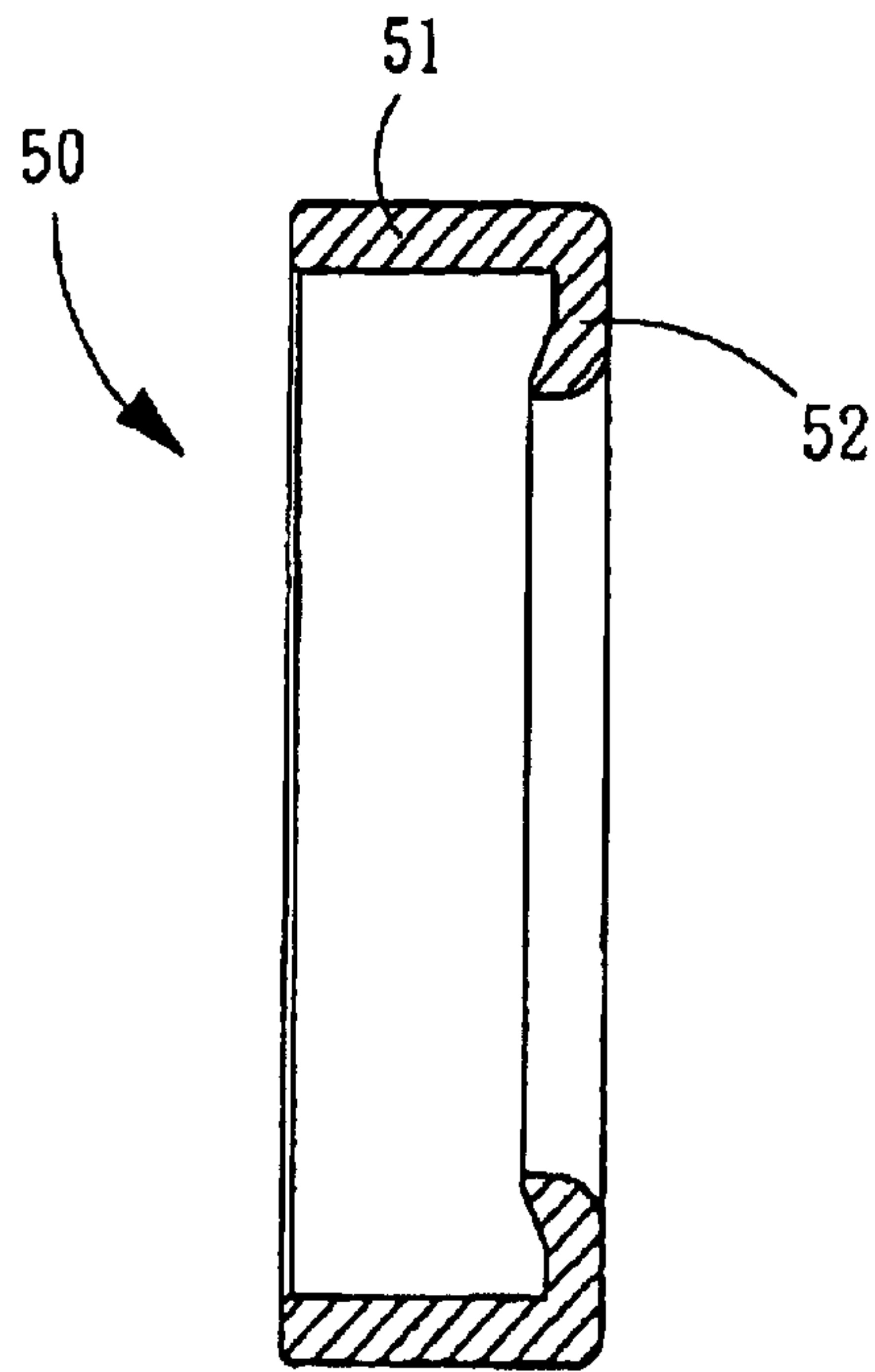

FIG. 6

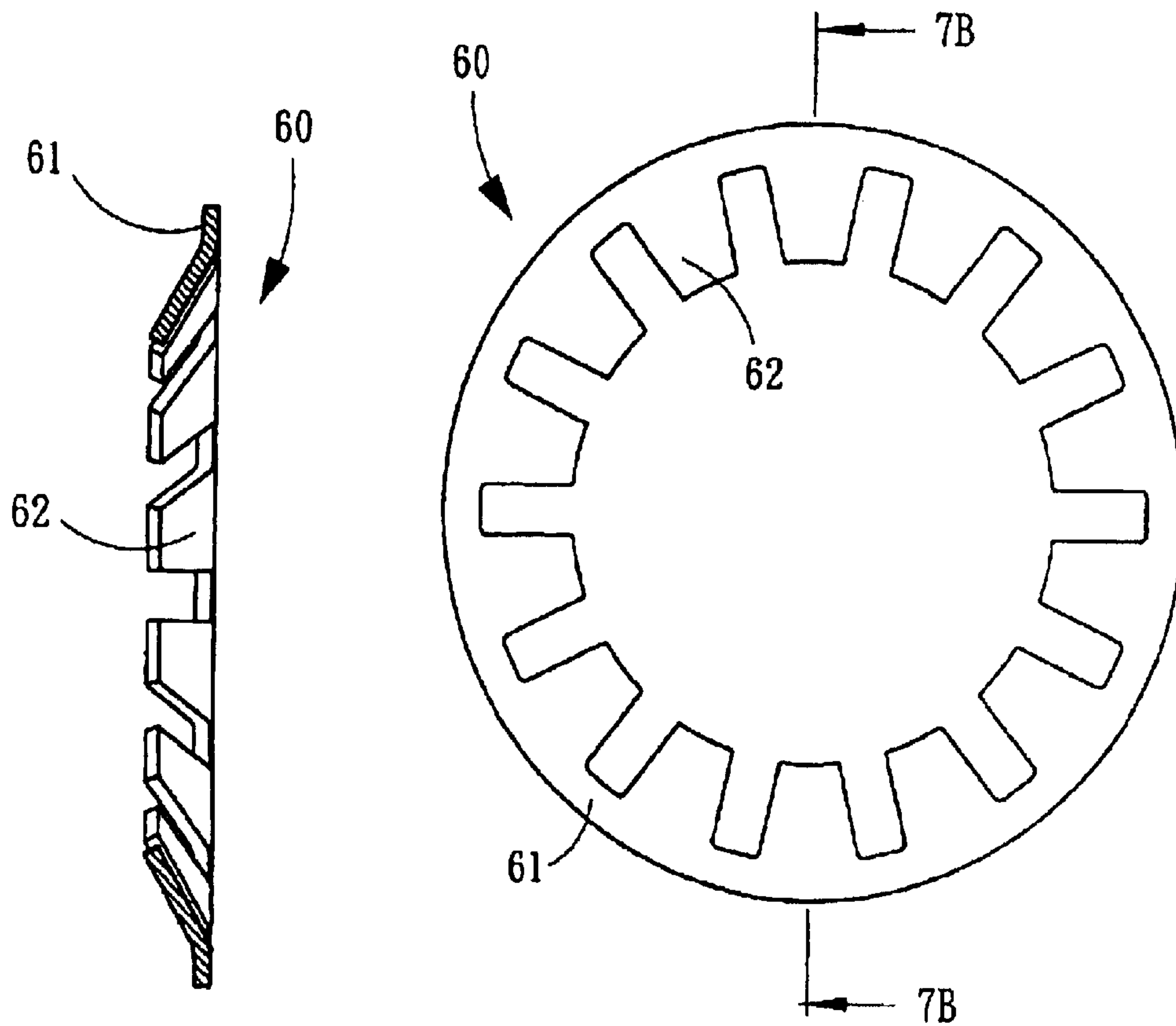

FIG. 7B

FIG. 7A

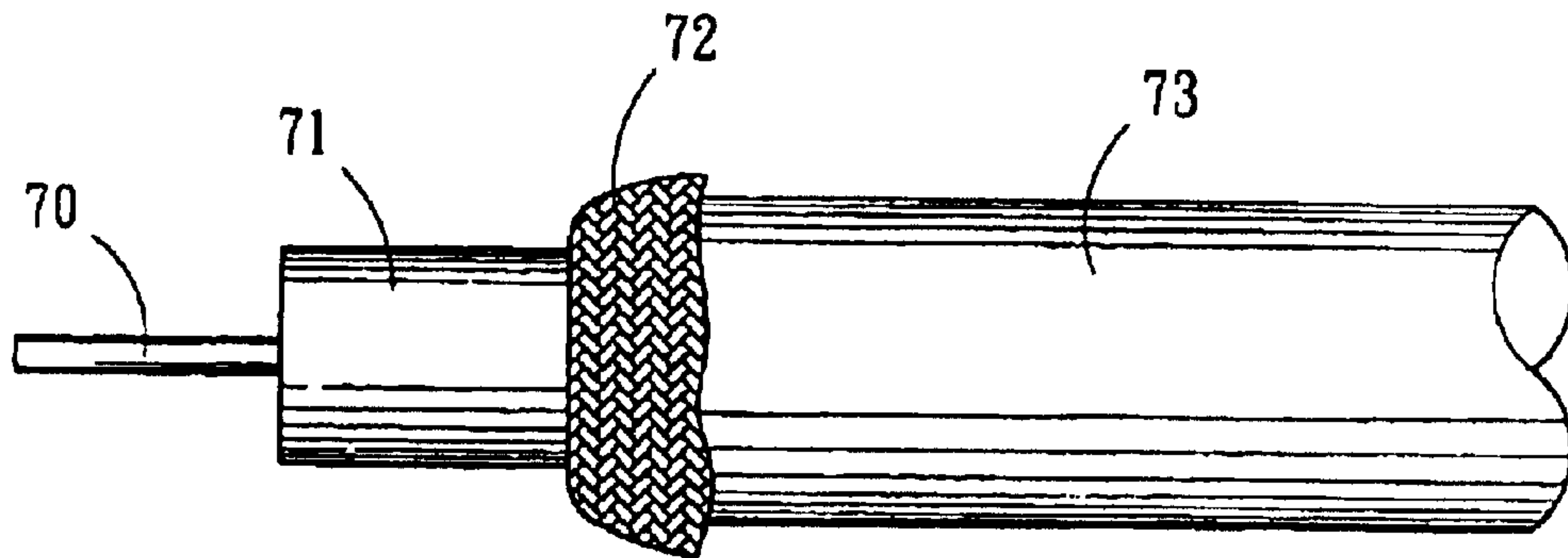

FIG. 8

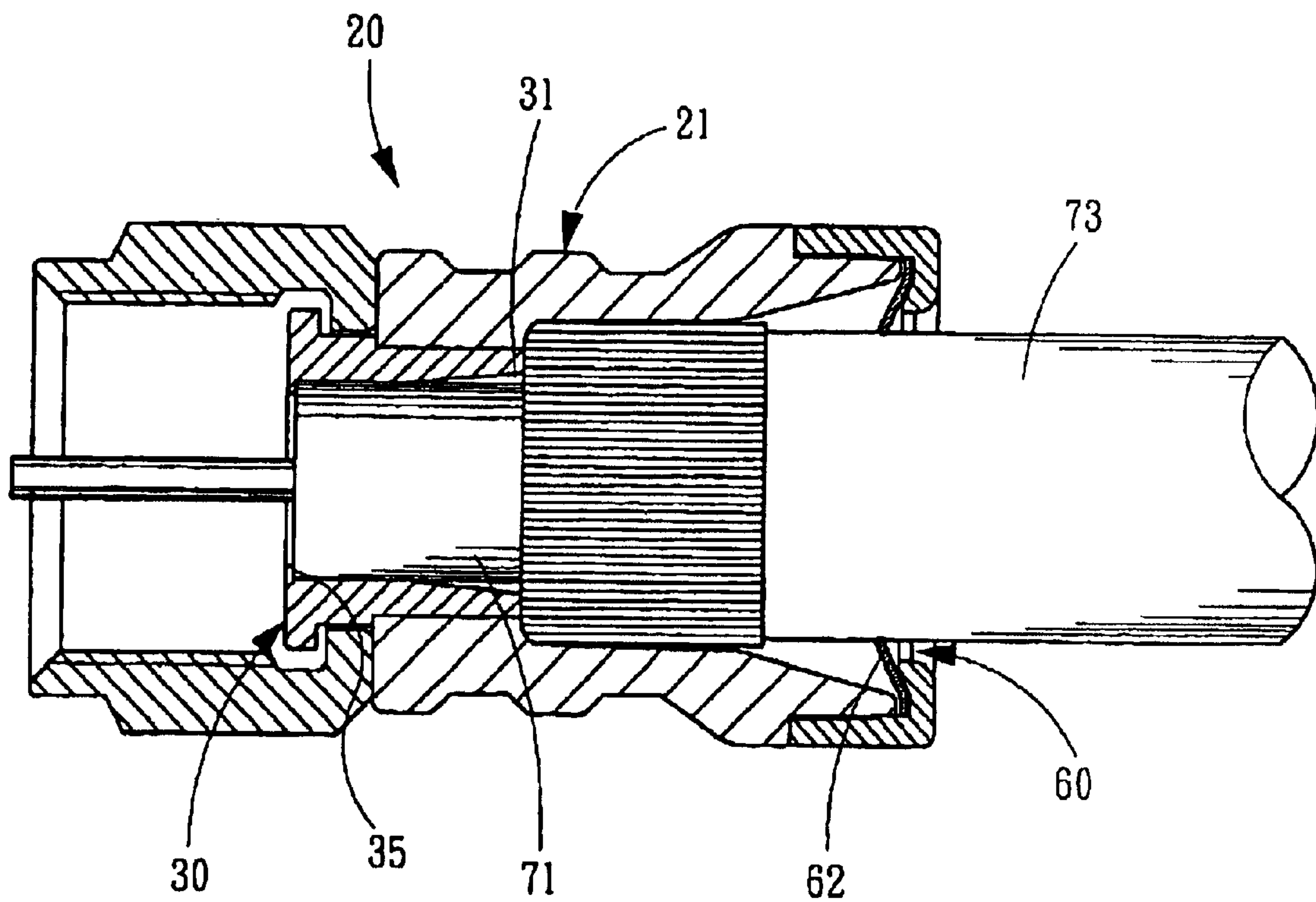

FIG. 9

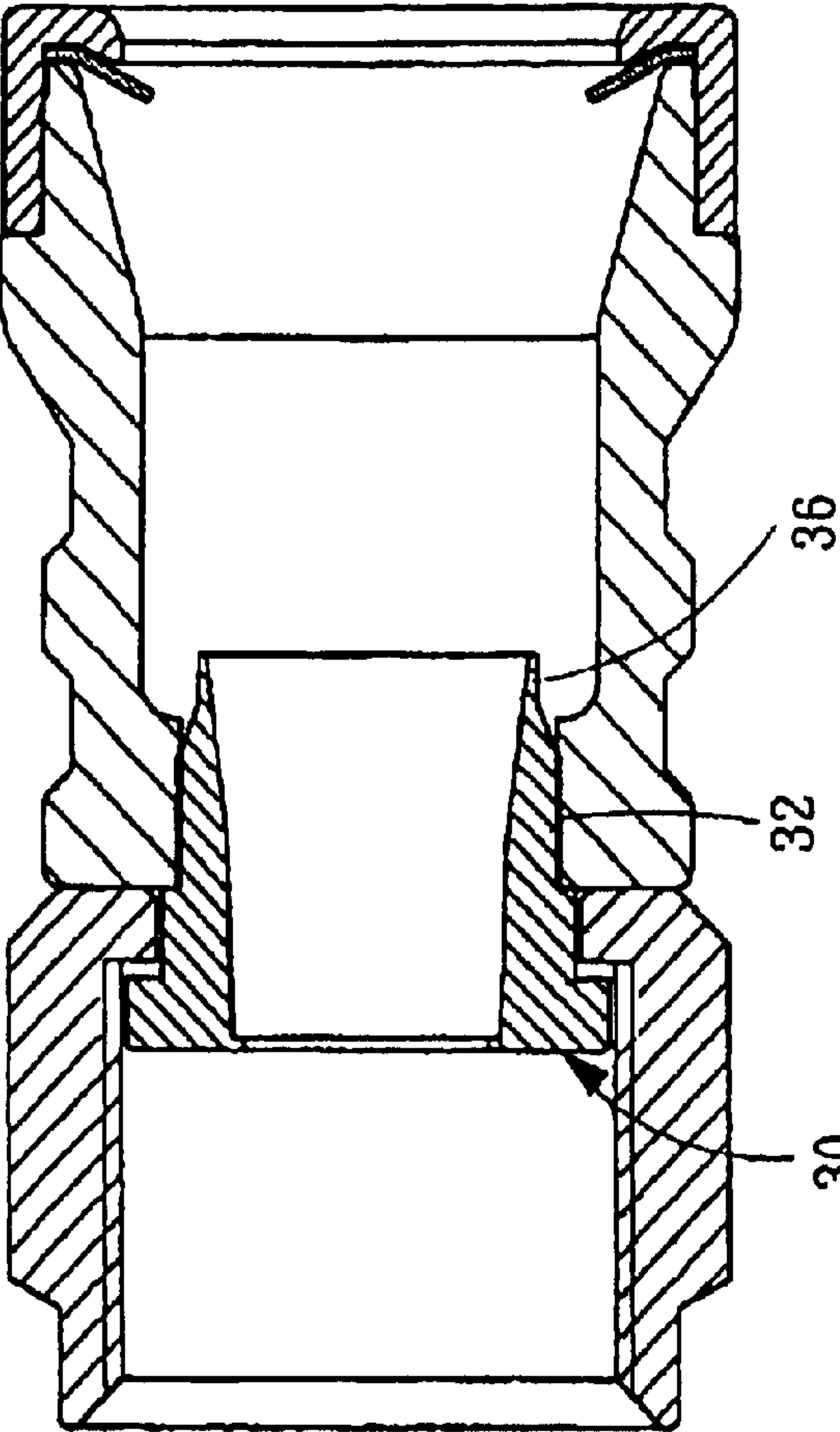

FIG. 10

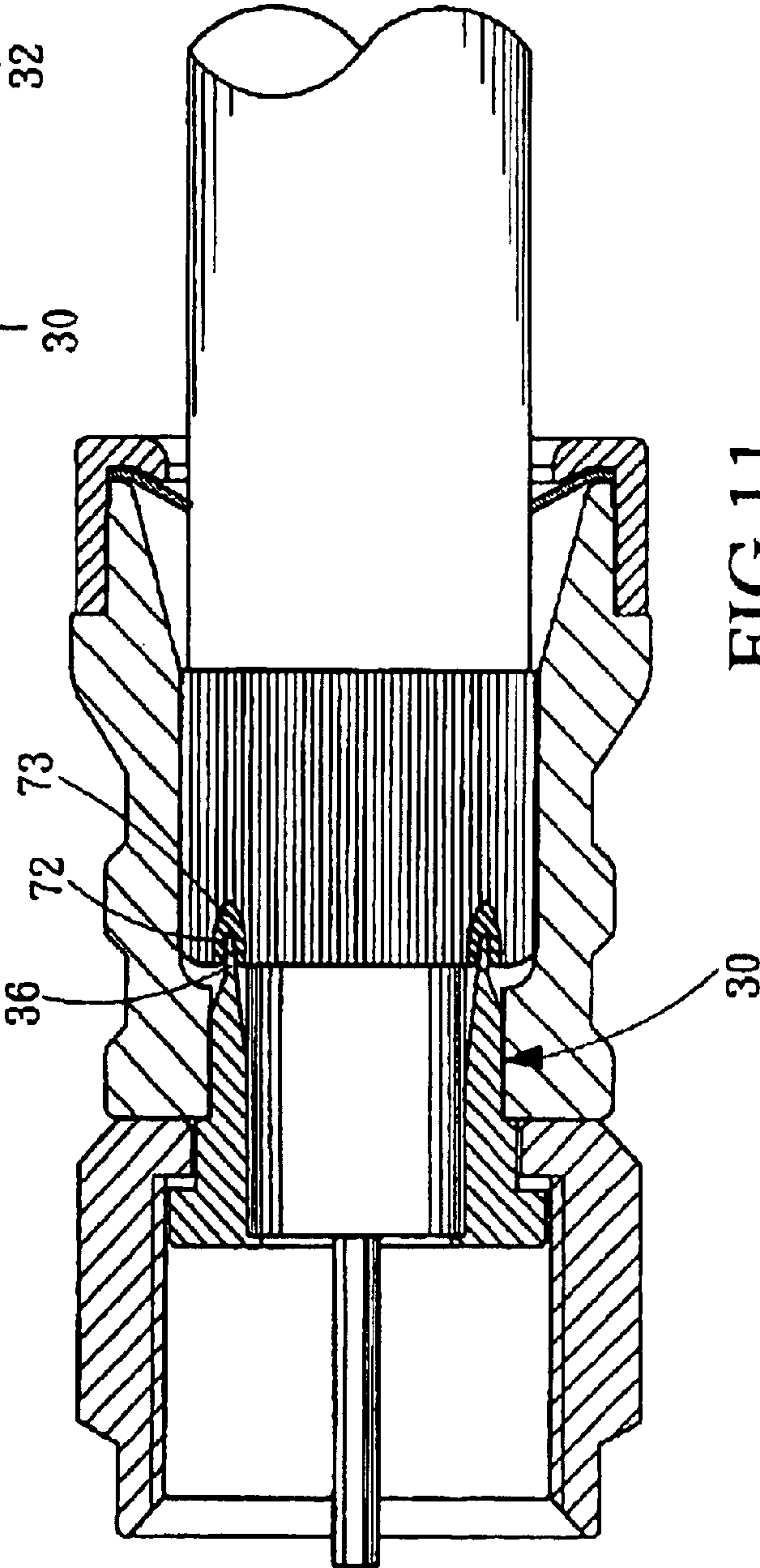

FIG. 11

1

CONNECTOR CAPABLE OF CONNECTING TO COAXIAL CABLE WITHOUT USING TOOL

Matter enclosed in heavy brackets [] appears in the original patent but forms no part of this reissue specification; matter printed in italics indicates the additions made by reissue.

BACKGROUND OF THE INVENTION

1. Field of the Invention

The present invention relates to connectors and more particularly to a connector capable of connecting to a coaxial cable without using a tool (e.g., pliers).

2. Description of Related Art

Connectors for coaxial cable are well known. A conventional F class connector of an electrical device (e.g., TV, radio, or the like) is threadedly coupled to a coaxial cable so that the electrical device is able to receive signals via the cable.

A conventional connector **10** for coaxial cable is shown in FIGS. **1A** and **1B**. The connector **10** comprises a rear, cylindrical shell **11**, an internal sleeve **12** surrounded by the shell **11**, and a nut **13** having internal threads coupled to a front end of the sleeve **12** (see FIG. **1A**). As shown in FIG. **1B**, the connector **10** is coupled at one end of a coaxial cable **15** by inserting the cable **15** through a rear end **14** of the connector **10**. Both a central conductor and an internal insulator of the cable **15** are inserted into the sleeve **12**. Both a braided outer conductor and a shield of the cable **15** are fitted in a space between the shell **11** and the sleeve **12**. Furthermore, the nut **13** is threadedly secured to a mated connector of an electrical device (not shown). Finally, a tool (e.g., pliers) is used to press the shell **11** against the shield of the cable **15** for fastening the connector **10** and the cable **15** together.

However, the prior art suffered from two disadvantages. The first one is an environmental problem. In detail, the shield of the cable made of soft PVC (polyvinyl chloride) is gradually replaced by one made of hard PE (polyethylene) for environmental protection. As such, it is impossible of connecting the hard shield of the cable to the connector by exerting force by the hand. Typically, a tool is used to compress one end of the cable into the connector. Next, as stated above, a pliers is used to press the shell **11** against the shield of the cable **15** for fastening the connector **10** and the cable **15** together. Such process is tedious. The second one is that the braided outer conductor of the cable **15** may be damaged during the coupling process. As such, it may degrade the signal transmission quality. Hence, a need for improvement exists.

SUMMARY OF THE INVENTION

It is an object of the present invention to provide a connector for a coaxial cable including a central conductor, an outer insulator surrounded the central conductor, a braided outer conductor in the form of a cylindrical shell surrounded the outer insulator, and a shield surrounded the outer conductor, the connector comprising an outer sleeve including a front, inwardly extending rim, a front bore section having a first diameter, an intermediate bore section having a second diameter larger than the first diameter for forming a shoulder therebetween, and a rear bore section having a flared opening; an inner sleeve including a front flange, a front, inwardly extending rim flush with the flange, and a rear flared opening; a forward rotatable nut including internal

2

threads for threadedly securing to a mated connector[,] and including a rear, inwardly extending rim; a hollow, cylindrical coupling including a rear, inwardly extending rim; and a resilient gripping ring including an annular section and a plurality of oblique teeth equally spaced apart around an inner edge thereof, wherein the rim of the nut is rotatably fitted between the outer sleeve and the flange and is sleeved on an intermediate portion of the inner sleeve, the rim of the outer sleeve is sleeved on the flared opening of the inner sleeve with the shoulder being flush with the flared opening of the inner sleeve, the annular section is sandwiched between the rim of the coupling and the flared opening of the rear bore section, and the coupling is sleeved on a rear portion of the outer sleeve; and a front end of the cable is inserted into the coupling and the ring for snugly fitting the outer insulator in a bore of the inner sleeve, the insertion is stopped as a front end of the outer insulator contacts the rim of the inner sleeve and front ends of the outer conductor and the shield contact both the shoulder and an edge of the flared opening of the inner sleeve, the central conductor is inserted into the mated connector for connection, and the teeth exert an inwardly gripping force onto an outer surface of the shield for fastening the front end of the cable in the connector. By utilizing the present invention, it is possible of connecting the connector to the coaxial cable without using a tool.

In one aspect of the present invention, the flared opening of the inner sleeve comprises a sharp edge capable of inserting through the outer conductor into the shield for further fastening the front end of the cable in the connector.

The above and other objects, features and advantages of the present invention will become apparent from the following detailed description taken with the accompanying drawings.

BRIEF DESCRIPTION OF THE DRAWINGS

FIG. **1A** is a cross-sectional view of a conventional connector for coaxial cable;

FIG. **1B** is a perspective view of the connector coupled to one end of the cable;

FIGS. **2A**, **2B** and **2C** are partial and full cross-sectional views and side view of a connector according to a first preferred embodiment of the invention respectively;

FIG. **3** is a cross-sectional view of the outer sleeve;

FIG. **4** is a cross-sectional view of the inner sleeve;

FIG. **5** is a cross-sectional view of the nut;

FIG. **6** is a cross-sectional view of the coupling;

FIG. **7A** is a front plan view of the resilient gripping ring;

FIG. **7B** is a cross-sectional view taken along line **7B—7B** of FIG. **7A**;

FIG. **8** is a side view of the cable;

FIG. **9** is a cross-sectional view of the cable coupled to the connector;

FIG. **10** is a cross-sectional view of a connector according to a second preferred embodiment of the invention; and

FIG. **11** is a cross-sectional view of the cable coupled to the connector of FIG. **10**.

DETAILED DESCRIPTION OF THE PREFERRED EMBODIMENTS

Referring to FIGS. **2A**, **2B**, **2C** and **8**, a connector constructed in accordance with a first preferred embodiment of the invention is shown. The connector comprises a body **20** including an outer sleeve **21**, an inner sleeve **30**, a forward

3

rotatable nut 40, and a hollow, cylindrical coupling 50, and a resilient gripping ring 60. Each component will be described in detail below.

Referring to FIG. 3, the outer sleeve 21 comprises a rear portion 27, a front, inwardly extending rim 25, and a bore consisting of a front section 25 for defining an opening 26 therein, an intermediate section 23 having a diameter larger than that of the front section 25 so as to form a shoulder 24 in a junction therebetween, and a rear section 22 having a flared opening.

Referring to FIG. 4, the inner sleeve 30 comprises a rear section 32, an intermediate section 33, a front flange 34, and a bore having a flared rear opening 31 and a front, inwardly extending rim 35 as a stop.

Referring to FIG. 5, the nut 40 comprises a front end 41, internal threads 43 for threadedly securing to a mated connector of an electrical device, and a hexagonal member 42 having an inwardly extending rim 44 for defining an opening 45 therein.

Referring to FIG. 6, the coupling 50 comprises a cylindrical portion 51 and a rear, inwardly extending rim 52 having an inwardly bent edge.

Referring to FIGS. 7A and 7B, the resilient gripping ring 60 comprises an annular section 61 and a plurality of oblique teeth 62 equally spaced apart around an inner edge thereof.

Referring to FIG. 8, a coaxial cable comprises a central conductor 70, an outer insulator 71 surrounded the central conductor 70, a braided outer conductor 72 in the form of a cylindrical shell surrounded the outer insulator 71, and a shield 73 surrounded the outer conductor 72. For connecting to the connector of the invention, one ends of the central conductor 70 and the outer insulator 71 are exposed. Also, one end of the outer conductor 72 is exposed and is covered on one end of the shield 73.

Referring to FIG. 9 in conjunction with FIGS. 1 to 8, locations of the components of the connector and the coupling operation of the connector and the cable will now be respectively described in detail below. As shown in FIG. 2B, the rim 44 is rotatably fitted between the front section 25 and the front flange 34 and the rim 44 is disposed around the intermediate section 33. The rim 25 is fitted around the rear section 32 with the shoulder 24 being flush with the rear opening 31. The annular section 61 is sandwiched between the rim 52 and the flared opening of the rear section 22. The cylindrical portion 51 is sleeved on the rear portion 27. As shown in FIG. 9, first insert the front end of the cable into the coupling 50 and the resilient gripping ring 60 for snugly fitting the outer insulator 71 in the bore of the inner sleeve 30. Also, the insertion is stopped as the front end of the outer insulator 71 contacts the rim 35 and the front ends of the outer conductor 72 and the shield 73 contact both the shoulder 24 and the rear opening 31. Further, the central conductor 70 is inserted into a conductive sleeve of a mated connector of an electrical device (not shown) for electrical connection. Moreover, the resilient teeth 62 exert an inwardly gripping force onto the outer surface of the shield 73 for fastening the front end of the cable in the connector.

Referring to FIGS. 10 and 11, a second preferred embodiment of the invention is shown. The second preferred embodiment substantially has same structure as the first preferred embodiment. The differences between the first and the second preferred embodiments, i.e., the characteristics of the second preferred embodiment are detailed below. The rear section 32 of the inner sleeve 30 has a sharp edge 36 capable

4

of inserting through the outer conductor 72 into the shield 73 for further fastening the front end of the cable in the connector.

In brief, the connection of the connector and the coaxial cable is done without using a tool. More importantly, the connection is reliable.

While the invention herein disclosed has been described by means of specific embodiments, numerous modifications and variations could be made thereto by those skilled in the art without departing from the scope and spirit of the invention set forth in the claims.

What is claimed is:

1. A connector connectable to a coaxial cable without using a tool, the cable including a central conductor, an outer insulator surrounded the central conductor, a braided outer conductor in the form of a cylindrical shell surrounded the outer insulator, and a shield surrounded the outer conductor, the connector comprising:

an outer sleeve including a front, inwardly extending rim, a front bore section having a first diameter, an intermediate bore section having a second diameter larger than the first diameter for forming a shoulder therebetween, and a rear bore section having a flared opening;

an inner sleeve including a front flange, a front, inwardly extending rim flush with the flange, and a rear flared opening;

a forward [rotatable nut including internal threads] member for [threadedly] securing to a mated connector[,] and including a rear, inwardly extending rim;

a hollow, cylindrical coupling including a rear, inwardly extending rim; and

a resilient gripping ring including an annular section and a plurality of oblique teeth equally spaced apart around an inner edge thereof,

wherein the rim of the [nut] forward member is [rotatably] fitted between the outer sleeve and the flange and is sleeved on an intermediate portion of the inner sleeve, the rim of the outer sleeve is sleeved on the flared opening of the inner sleeve with the shoulder being flush with the flared opening of the inner sleeve, the annular section is sandwiched between the rim of the coupling and the flared opening of the rear bore section, and the coupling is sleeved on a rear portion of the outer sleeve; and a front end of the cable is inserted into the coupling and the ring for snugly fitting the outer insulator in a bore of the inner sleeve, the insertion is stopped as a front end of the outer insulator contacts the rim of the inner sleeve and front ends of the outer conductor and the shield contact both the shoulder and an edge of the flared opening of the inner sleeve, the central conductor is inserted into the mated connector for connection, and the teeth exert an inwardly gripping force onto an outer surface of the shield for fastening the front end of the cable in the connector.

2. The connector of claim 1, wherein the rim of the coupling comprises an inwardly bent edge.

3. The connector of claim 1, wherein the flared opening of the inner sleeve comprises a sharp edge capable of inserting through the outer conductor into the shield for further fastening the front end of the cable in the connector.

4. The connector of claim 1, wherein the forward member for securing to a mated connector is a nut having internal threads for threaded engagement to the mated connector.