

US00RE41029E

(19) **United States**
(12) **Reissued Patent**
Guglielmi et al.

(10) **Patent Number:** **US RE41,029 E**
(45) **Date of Reissued Patent:** **Dec. 1, 2009**

(54) **ENDOVASCULAR ELECTROLYTICALLY DETACHABLE WIRE AND TIP FOR THE FORMATION OF THROMBUS IN ARTERIES, VEINS, ANEURYSMS, VASCULAR MALFORMATIONS AND ARTERIOVENOUS FISTULAS**

(75) Inventors: **Guido Guglielmi**, Rome (IT); **Ivan Sepetka**, Los Altos, CA (US)

(73) Assignee: **The Regents of the University of California**, Oakland, CA (US)

(21) Appl. No.: **11/377,895**

(22) Filed: **Mar. 15, 2006**

Related U.S. Patent Documents

Reissue of:

(64) Patent No.: **5,895,385**
Issued: **Apr. 20, 1999**
Appl. No.: **08/944,827**
Filed: **Nov. 6, 1997**

U.S. Applications:

(63) Continuation of application No. 08/801,795, filed on Feb. 14, 1997, now Pat. No. 5,855,578, which is a continuation of application No. 08/485,821, filed on Jun. 6, 1995, now abandoned, which is a division of application No. 08/311,508, filed on Sep. 23, 1994, now Pat. No. 5,540,680, which is a continuation of application No. 07/840,211, filed on Feb. 24, 1992, now Pat. No. 5,354,295, which is a continuation-in-part of application No. 07/492,717, filed on Mar. 13, 1990, now Pat. No. 5,122,136.

(51) **Int. Cl.**
A61B 18/04 (2006.01)
A61B 17/12 (2006.01)
A61B 18/14 (2006.01)
A61B 18/12 (2006.01)
A61B 17/00 (2006.01)

(52) **U.S. Cl.** **606/32; 606/41; 606/108; 606/191**

(58) **Field of Classification Search** None
See application file for complete search history.

(56) **References Cited**

U.S. PATENT DOCUMENTS

4,512,338 A * 4/1985 Balko et al.

(Continued)

FOREIGN PATENT DOCUMENTS

CA 2179863 12/1996

(Continued)

OTHER PUBLICATIONS

Anderson et al, "Transcatheter Intravascular Coil Occlusion of Experimental Fistulas", Am. J. Roentgenology, Oct./Nov. 1977, pp. 795-798, vol. 129.*

(Continued)

Primary Examiner—Michael Peffley

(74) Attorney, Agent, or Firm—Fenwick & West LLP

(57)

ABSTRACT

An artery, vein, aneurysms vascular malformation or arterial fistula is occluded through endovascular occlusion by the endovascular insertion of a platinum wire and/or tip into the vascular cavity. The vascular cavity is packed with the tip to obstruct blood flow or access of blood in the cavity such that the blood clots in the cavity and an occlusion is formed. The tip may be elongate and flexible so that it packs the cavity by being folded upon itself a multiple number of times, or may pack the cavity by virtue of a filamentary or fuzzy structure of the tip. The tip is then separated from the wire mechanically or by electrolytic separation of the tip from the wire. The wire and the microcatheter are thereafter removed leaving the tip embedded in the thrombus formed within the vascular cavity. Movement of wire in the microcatheter is more easily tracked by providing a radioopaque proximal marker on the microcatheter and a corresponding indicator marker on the wire. Electrothrombosis is facilitated by placing the ground electrode on the distal end of the microcatheter and flowing current between the microcatheter electrode and the tip.

REEXAMINATION RESULTS

The questions raised in reexamination request 90/007,231, filed Oct. 4, 2004 have been considered and the results thereof are reflected in this reissue patent which constitutes the reexamination certificate required by 35 U.S.C. 307 as provided in 37 CFR 1.570(e), for ex parte reexaminations, or the reexamination certificate required by 35 U.S.C. 316 as provided in 37 CFR 1.99(e) for inter partes reexaminations.

47 Claims, 6 Drawing Sheets

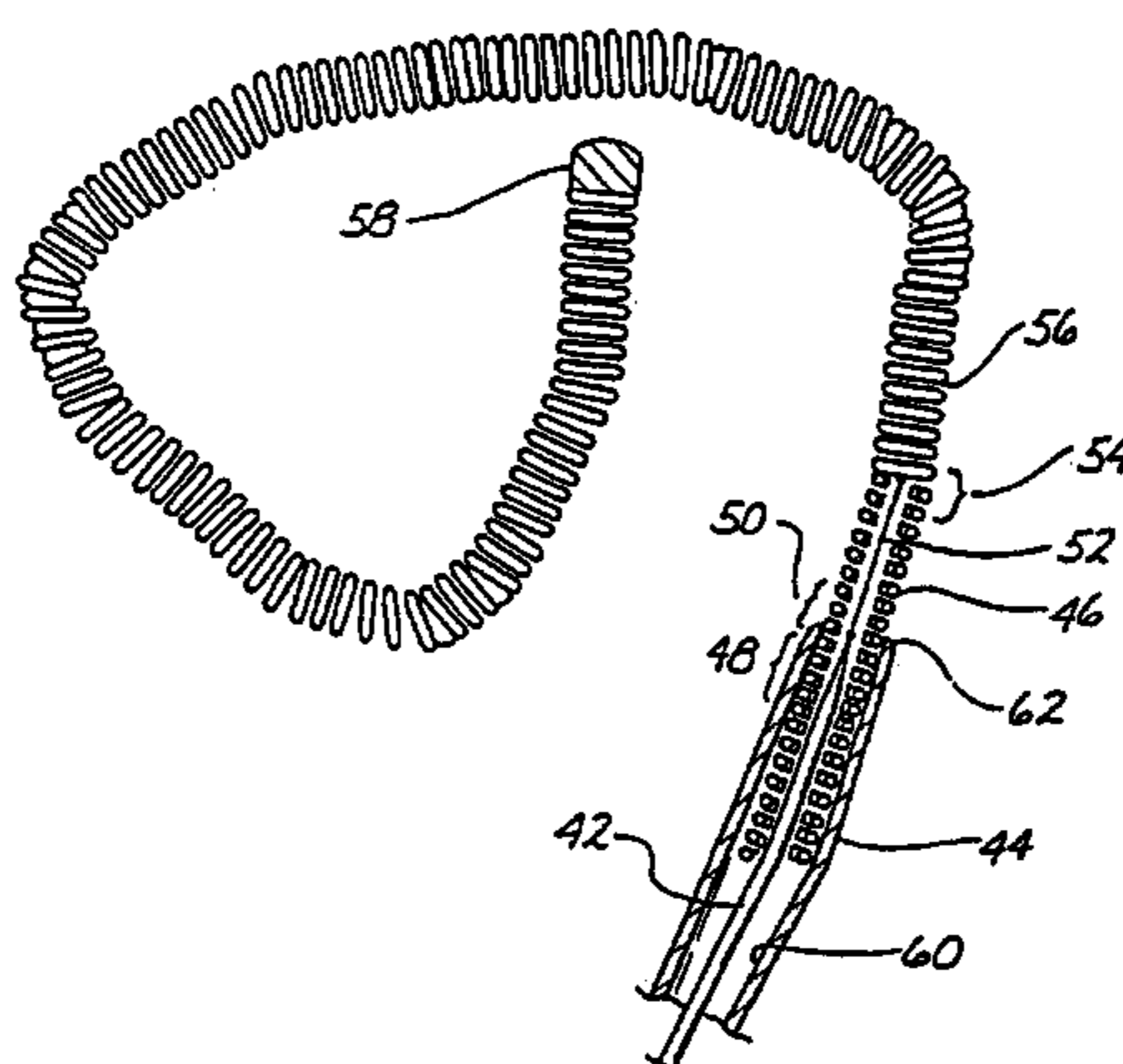

U.S. PATENT DOCUMENTS

4,735,201	A *	4/1988	O'Reilly	
4,739,768	A *	4/1988	Engelson	
4,748,986	A *	6/1988	Morrison et al.	
4,820,298	A *	4/1989	Leveen et al.	
4,884,579	A *	12/1989	Engelson	
4,994,069	A *	2/1991	Ritchart et al.	606/191
5,108,407	A *	4/1992	Geremia et al.	
5,209,730	A *	5/1993	Sullivan	604/103.1
5,261,916	A *	11/1993	Engelson	606/108
5,304,195	A *	4/1994	Twyford et al.	606/191
5,354,295	A *	10/1994	Guglielmi et al.	606/32

FOREIGN PATENT DOCUMENTS

CA	2055492	C	11/2000
DD	158.084		12/1982
DD	223 065	A1	6/1985
DE	3 203 410		11/1982
DE	69131466	T2	11/1999
DE	69131467	T2	11/1999
DE	69233026	T2	1/2004
DE	69627243	T2	1/2004
EP	0 804 906	A3	5/1997
EP	0 803 230	A3	11/1997
EP	0 804 904	A1	11/1997
EP	0 804 905	A1	11/1997
EP	0 804 906	B1	1/1999
EP	0 804 905	B1	7/1999
EP	1 005 837	A3	6/2000
EP	1 005 837	A2	6/2000
EP	0 803 230	B1	11/2000
EP	1 005 837	B1	4/2003
EP	0 914 803	B1	7/2003
EP	1 323 385	A2	7/2003
EP	1 323 385	A3	7/2003
EP	1 329 196	A1	7/2003
WO	WO 91/13592	*	9/1991
WO	WO 92/01425	*	2/1992
WO	WO 93/11825	*	6/1996

OTHER PUBLICATIONS

Zuniga et al., "A New Device for Safe Delivery of Stainless Steel Coils" *Radiology* vol. 136, pp. 230-231, Jul. 1980.*
 Target Therapeutics. "History of the Guglielmi Detachable Coil." *History of the GDC*, pp. 1-6 Oct. 1995.*

Guglielmi et al., "Intravascular Electrothrombosis in Experimentally Induced Vascular Malformation," *Assoziaone Italiani di Neurodiologia*, Sep. 29-30, 1983, pp. 139-146.*
 Sadato et al., "Immediately Detachable Coil for Aneurysms Treatment," *ANJR* 16: 1459-1462 Aug. 1995.*
 Mullan, "Eperiences with Surgical Thrombosis of Intracranial Berry Aneurysms and Carotid Cavernous Fistulas". *J. Neurosurg.*, vol. 41, Dec. 1974, pp. 657-670.*
 Hosobuchi, "Electrothrombosis Carotid-Cavernous Fistula", *J. Neurosurg.*, vol. 42, Jan. 1975, pp. 76-85.*
 Araki et al., "Electrically Induced Thrombosis for the Treatment of Intracranial Aneurysms and Angiomas", *Excerpts Medica International Congress Series*, Amsterdam 1965. vol. 110, pp. 651-654.*
 Sawyer et al., "Bio-Electric Phenomena as an Etiological factor in Intravascular Thrombosis", *Am.. J. Physiol.*, vol. 175, pp. 103-107 (1953).*
 J. Piton et al., "Selective Vascular Thrombosis Induced by a Direct Electrical Current; Animal Experiments", *J. Neurodiology*, vol. 5, pp. 139-152 (1978).*
 Hilal, et al., "Synthetic Fiber-Coated Platinum Coils Successfully Used for the Endovascular Treatment of Arteriovenous Malformation . . .", *Twenty-Sixth Annual Meeting, Session 10G, Paper 175, May 15, 1988.**
 Thompson et al., "Transcatheter Electrocoagulation: Experimental Evaluation of the Anode", *Investigative Radiology*. vol. 14, Jan.-Feb. 1979, pp. 41-47.*
 Alksne et al., "Stereotactic Occlusion of 22 consecutive anterior communicating artery aneurysms", *J. Neurosurg.*, vol. 52, Jan. 1980, pp. 790-793.*
 Debrun, et al., "Detachable balloon and calibrated-leak balloon techniques in the treatment of cerebral vascular lesions." *J. Neurosurg.* vol. 49, Nov. 1978; pp. 635-649.*
 Mullan et al., "Stereotactic Copper electric Thrombosis of Intracranial Aneurysms," *Progr. neurol., Surg.*, vol. 3, pp. 193-211 (1969).*
 Serbinenko, "Balloon catheterization and occlusion of major cerebral vessels," *J. Neurosurg.*, vol. 41, Aug. 1974, pp. 125-145.*

* cited by examiner

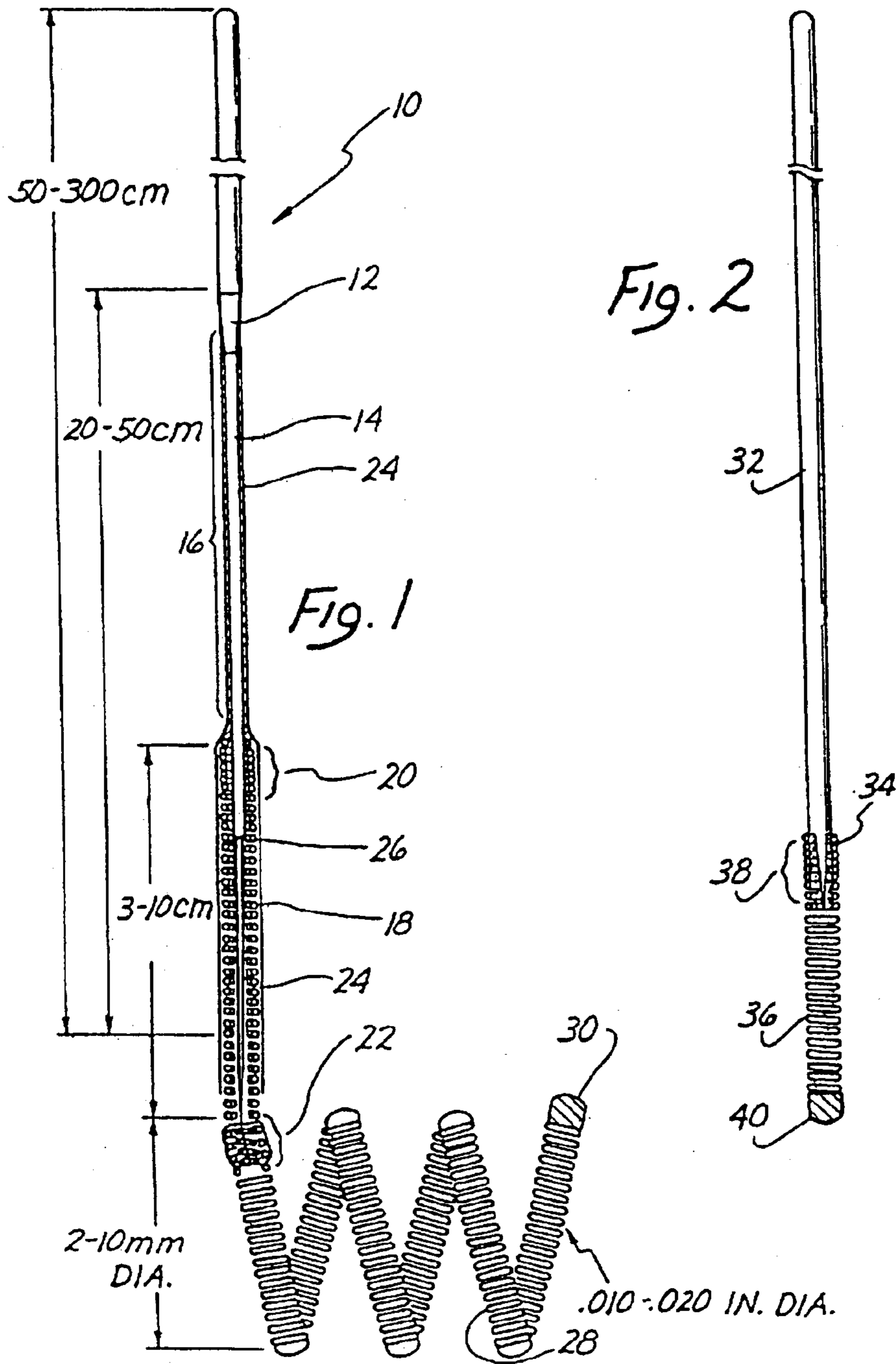

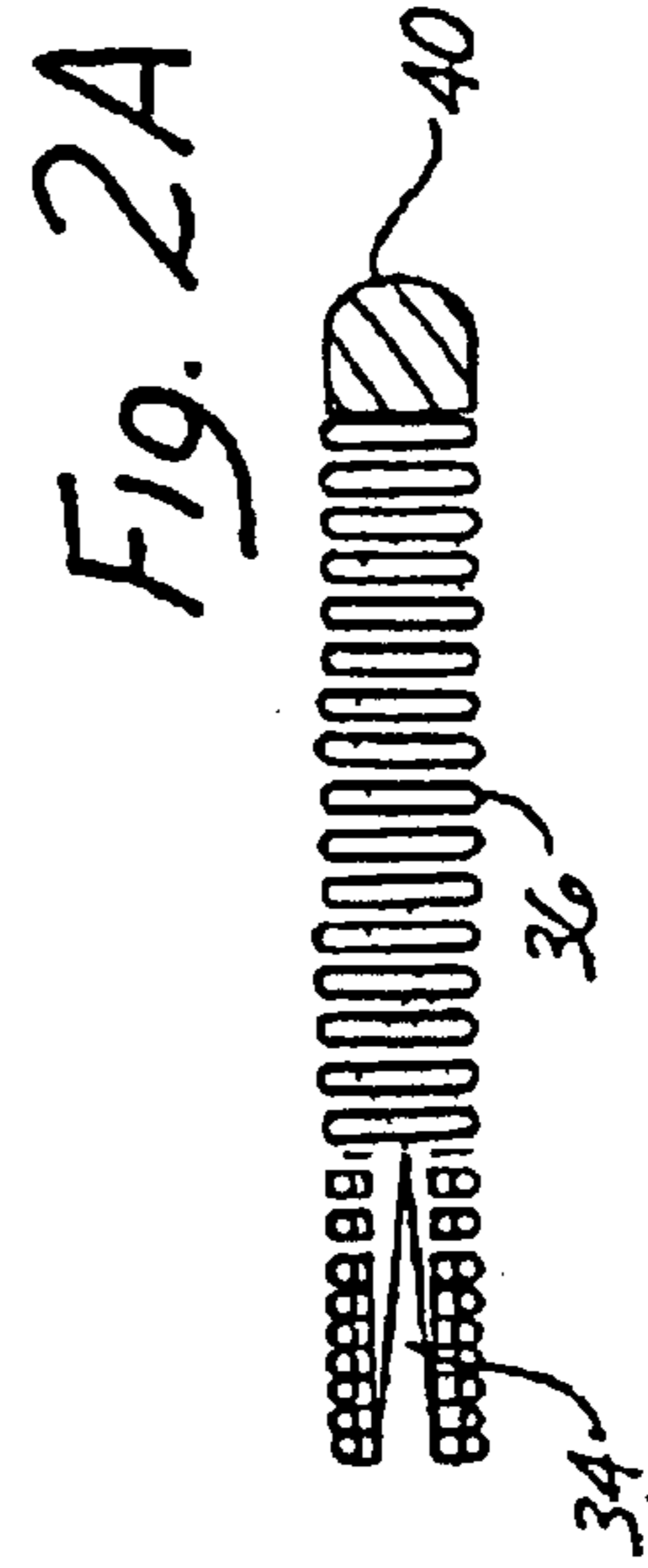
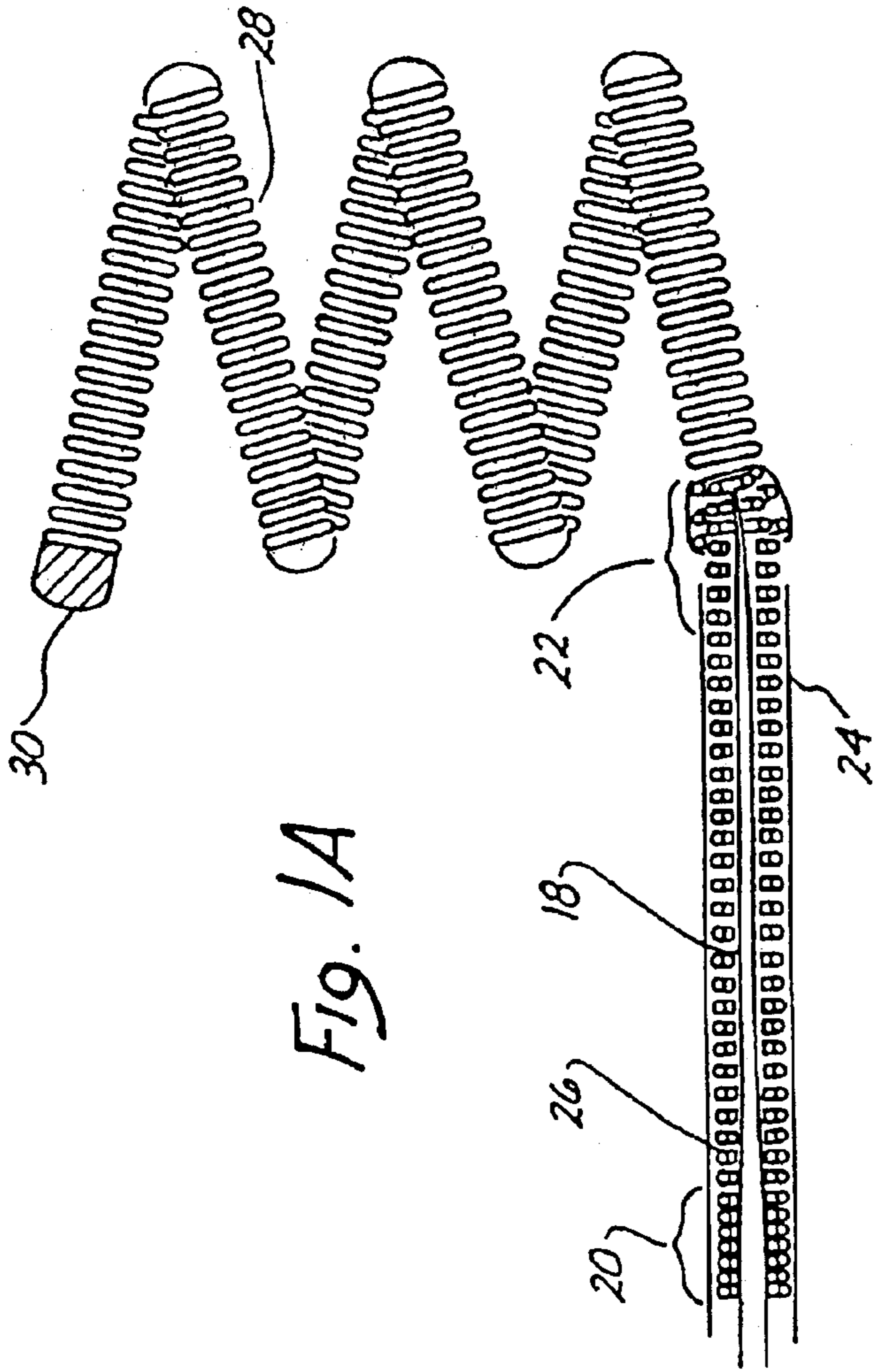

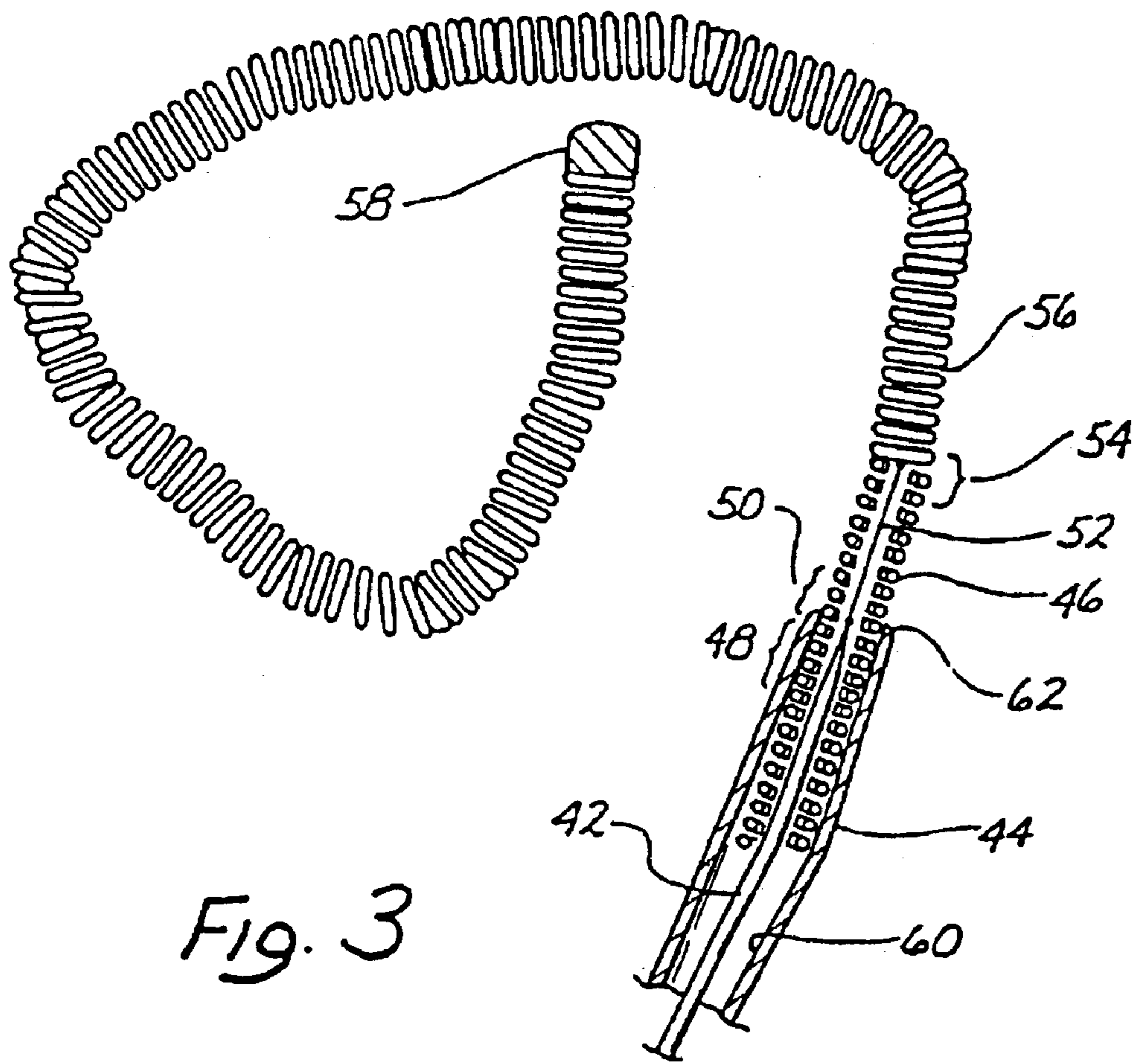
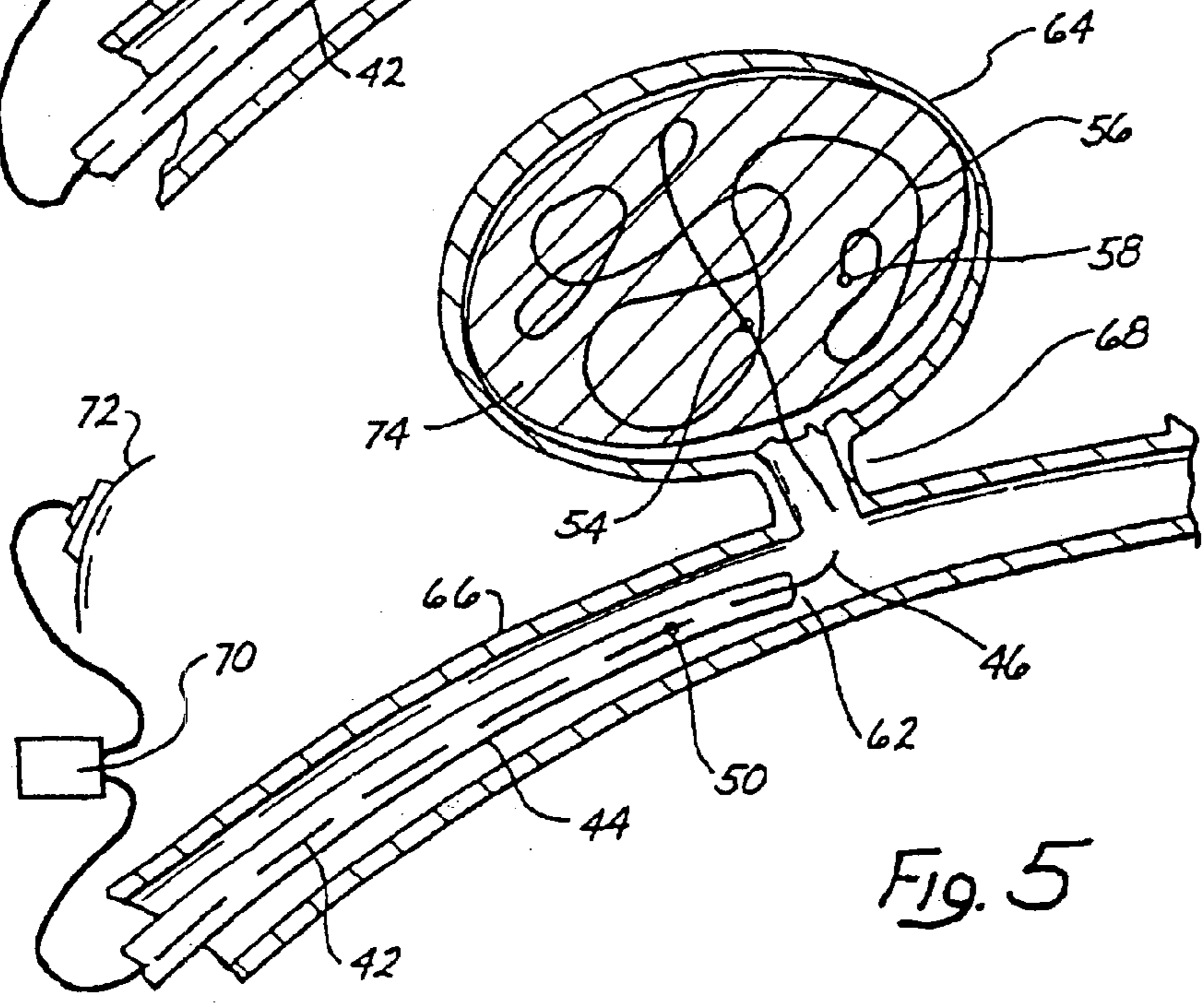
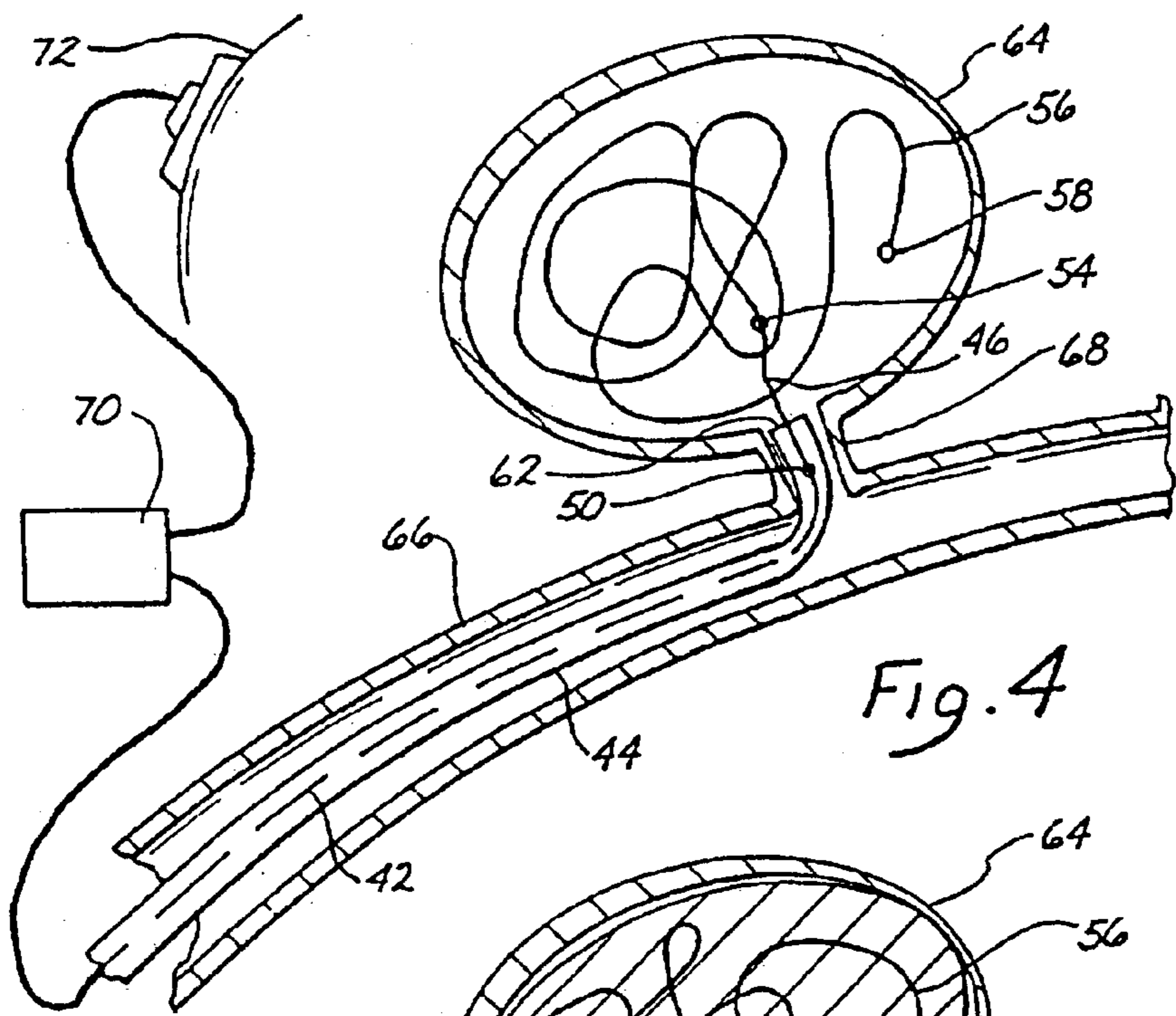
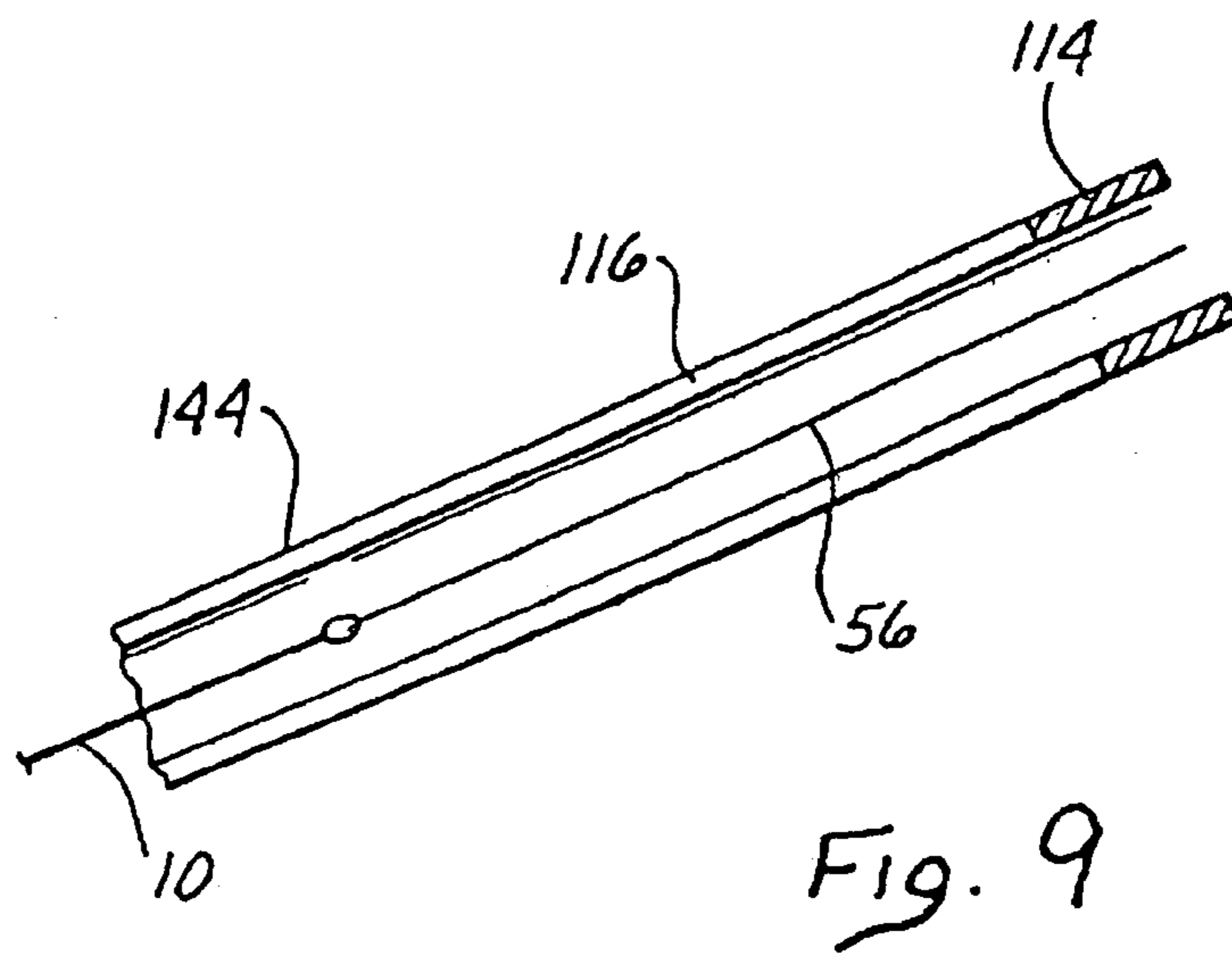
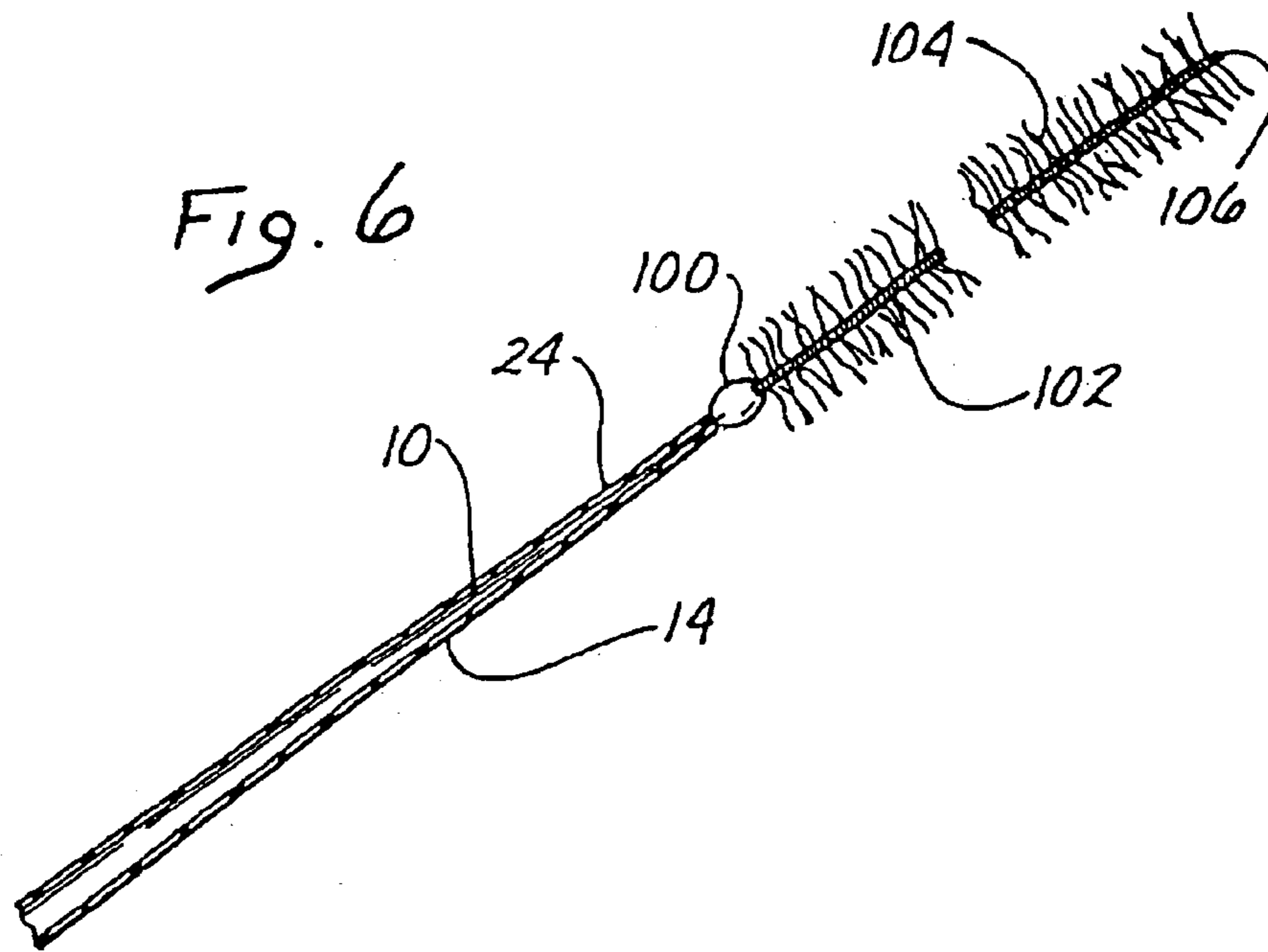
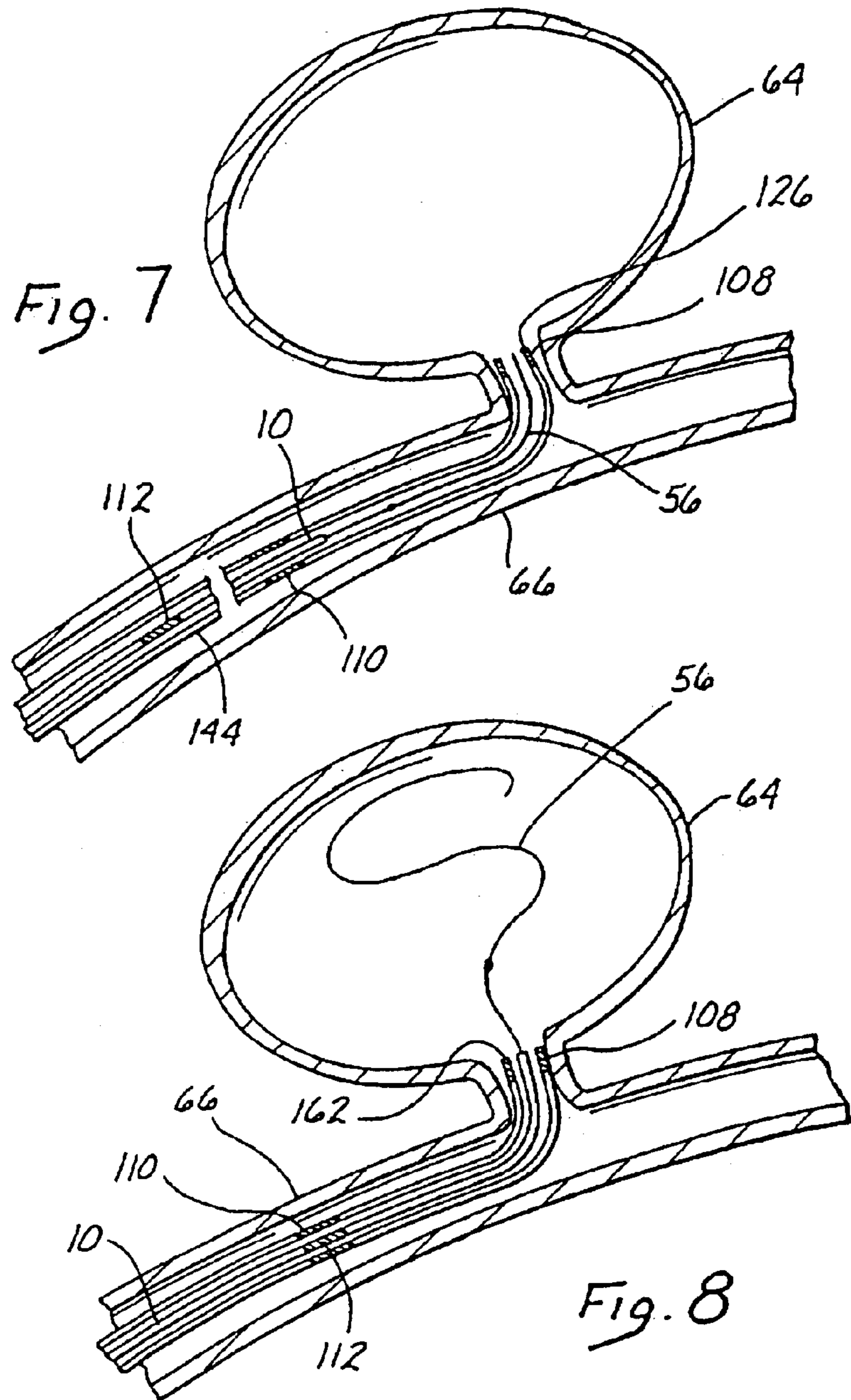

Fig. 3







**ENDOVASCULAR ELECTROLYTICALLY
DETACHABLE WIRE AND TIP FOR THE
FORMATION OF THROMBUS IN ARTERIES,
VEINS, ANEURYSMS, VASCULAR
MALFORMATIONS AND ARTERIOVENOUS
FISTULAS**

Matter enclosed in heavy brackets [] appears in the original patent but forms no part of this reissue specification; matter printed in italics indicates the additions made by reissue.

This application is a continuation of application Ser. No. 08/801,795 filed Feb. 14, 1997, issued as U.S. Pat. No. 5,885,578, which in turn [was] is a continuation of application Ser. No. 08/485,821, filed Jun. 6, 1995, now abandoned, which is a divisional of application Ser. No. 08/311,508, filed on Sep. 23, 1994, issued as U.S. Pat. No. 5,540,680, which is a continuation application of application Ser. No. 07/840,211 filed on Feb. 24, 1992, issued as U.S. Pat. No. 5,354,295, and which in its turn [was] is a continuation-in-part application of application Ser. No. 07/492,717, filed Mar. 13, 1990, issued as U.S. Pat. No. 5,122,136.

BACKGROUND OF THE INVENTION

1. Field of the Invention

The invention relates to a method and apparatus for endovascular electrothrombic formation of thrombi in arteries, veins, aneurysms, vascular malformations and arteriovenous fistulas.

2. Description of the Prior Art

Approximately 25,000 intracranial aneurysms rupture every year in North America. The primary purpose of treatment for ruptured intracranial aneurysm is to prevent rebleeding. At the present time, three general methods of treatment exist, namely an extravascular, endovascular and extra-endovascular approach.

The extravascular approach is comprised of surgery or microsurgery of the aneurysm or treatment site for the purpose of preserving the parent artery. This treatment is common with intracranial berry aneurysms. The methodology comprises the step of clipping the neck of the aneurysm, performing a sutureligation of the neck, or wrapping the entire aneurysm. Each of these surgical procedures is performed by intrusive invasion into the body and performed from outside the aneurysm or target site. General anesthesia, craniotomy, brain retraction and arachnoid dissection around the neck of the aneurysm and placement of a clip are typically required in these surgical procedures. Surgical treatment of vascular intracranial aneurysm can expect a mortality rate of 4–8% with a morbidity rate of 18–20%. Because of the mortality and morbidity rate expected, the surgical procedure is often delayed while waiting for the best surgical time with the result that an additional percentage of patients will die from the underlying disease or defect prior to surgery. For this reason the prior art has sought alternative means of treatment.

In the endovascular approach, the interior of the aneurysm is entered through the use of a microcatheter. Recently developed microcatheters, such as those shown by Engelson, "Catheter Guidewire", U.S. Pat. No. 4,884,579 and as described in Engelson, "Catheter for Guidewire Trackzng", U.S. Pat. No. 4,739,768 (1998), allow navigation into the cerebral arteries and entry into cranial aneurysm.

In such procedures a balloon is typically attached to the end of the microcatheter and it is possible to introduce the balloon into the aneurysm, inflate it, and detach it, leaving it

to occlude the sac and neck with preservation of the parent artery. While endovascular balloon embolization of berry aneurysms is an attractive method in situations where an extravascular surgical approach is difficult, inflation of a balloon into the aneurysm carries some risk of aneurysm rupture due to possible over-distention of portions of the sac and due to the traction produced while detaching the balloon.

While remedial procedures exist for treating a ruptured aneurysm during classical extravascular surgery, no satisfactory methodology exists if the aneurysm breaks during an endovascular balloon embolization.

Furthermore, an ideal embolizing agent should adapt itself to the irregular shape of the internal walls of the aneurysm. On the contrary, in a balloon embolization the aneurysmal wall must conform to the shape of the balloon. This may not lead to a satisfactory result and further increase the risk of rupture.

Still further, balloon embolization is not always possible. If the diameter of the deflated balloon is too great to enter the intracerebral arteries, especially in the cases where there is a vasospasm, complications with ruptured intracranial aneurysms may occur. The procedure then must be deferred until the spasm is resolved and this then incurs a risk of rebleeding.

In the extra-intravascular approach, an aneurysm is surgically exposed or stereotaxically reached with a probe. The wall of the aneurysm is then performed from the outside and various techniques are used to occlude the interior in order to prevent it from rebleeding. These prior art techniques include electrothrombosis, isobutyl-cyanoacrylate embolization, hog-hair embolization and ferromagnetic thrombosis.

In the use of electrothrombosis for extra-intravascular treatment the tip of a positively charged electrode is inserted surgically into the interior of the aneurysm. An application of the positive charge attracts white blood cells, red blood cells, platelets and fibrinogen which are typically negatively charged at the normal pH of the blood. The thrombic mass is then formed in the aneurysm about the tip. Thereafter, the tip is removed, See Mullan, "Experiences with Surgical Thrombosis of Intracranial Berry Aneurysms and Carotid Cavernous Fistulas": J. Neurosurg., Vol. 41, December 1974; Hosobuchi, "Electrothrombosis Carotid-Cavernous Fistula", J. Neurosurg., Vol. 42, January 1975; Afaki et al., "Electrically Induced Thrombosis for the Treatment of Intracranial Aneurysms and Angiomas", Excerpta Medica International Congress Series, Amsterdam 1965, Vol. 110, 651–654; Sawyer et al., "Bio-Electric Phenomena as an Etiological Factor in Intravascular Thrombosis", Am. J. Physiol., Vol. 175, 103–107 (1953); J. Piton et al., "Selective Vascular Thrombosis Induced by a Direct Electrical Current; Animal Experiments", J. Neuroradiology. Vol. 5, pages 139–152 (1978). However, each of these techniques involves some type of intrusive procedure to approach the aneurysm from the exterior of the body.

The prior art has also devised the use of a liquid adhesive isobutylcyanoacrylate (IBCA) which polymerizes rapidly on contact with blood to form it firm mass. The liquid adhesive is injected into the aneurysm by puncturing the sac with a small needle. In order to avoid spillage into the parent artery during IBCA injection, blood flow through the parent artery must be momentarily reduced or interrupted. Alternatively, an inflated balloon may be placed in the artery at the level of the neck of the aneurysm for injection. In addition to the risks caused by temporary blockage of the parent artery, the risks of seepage of such a polymerizing adhesive into the

parent artery exists, if it is not completely blocked with consequent occlusion of the artery.

Still further, the prior art has utilized an air gun to inject hog hair through the aneurysm wall to induce internal thrombosis. The success of this procedure involves exposing the aneurysm sufficiently to allow air gun injection and has not been convincingly shown as successful for thrombotic formations.

Ferromagnetic thrombosis in the prior art in extraintravascular treatments comprises the stereotactic placement of a magnetic probe against the sac of the aneurysm followed by injection into the aneurysm by an injecting needle of iron microspheres. Aggregation of the microspheres through the extravascular magnet is followed by interaneurysmatic thrombus. This treatment has not been entirely successful because of the risk of fragmentation of the metallic thrombus when the extravascular magnet is removed. Suspension of the iron powder in methyl methacrylate has been used to prevent fragmentation. The treatment has not been favored, because of the need to puncture the aneurysm, the risk of occlusion of the parent artery, the use of unusual and expensive equipment, the need for a craniectomy and general anesthesia, and the necessity to penetrate cerebral tissue to reach the aneurysm.

Endovascular coagulation of blood is also well known in the art and a device using laser optically generated heat is shown by O'Reilly, "Optical Fiber with Attachable Metallic Tip for Intravascular Laser Coagulation of Arteries, Veins, Aneurysms, Vascular Malformation and Arteriovenous Fistulas", U.S. Pat. No. 4,735,201 (1988). See also, O'Reilly et al., "Laser Induced Thermal Occlusion of Berry Aneurysms: Initial experimental Results", *Radiology*, Vol. 171, No. 2, pages 471-74 (1989). O'Reilly places a tip into an aneurysm by means of an endovascular microcatheter. The tip is adhesively bonded to an optic fiber disposed through the microcatheter. Optical energy is transmitted along the optic fiber from a remote laser at the proximal end of the microcatheter. The optical energy heats the tip of cauterize the tissue surrounding the neck of the aneurysm or other vascular opening to be occluded. The catheter is provided with a balloon located on or adjacent to its distal end to cut off blood flow to the site to be cauterized and occluded. Normally, the blood flow would carry away the heat at the catheter tip, thereby preventing cauterization. The heat in the tip also, serves to melt the adhesive used to secure the tip to the distal end of the optical fiber. If all goes well, the tip can be separated from the optical fiber and left in place in the neck of the aneurysm, provided that the cauterization is complete at the same time as the hot melt adhesive melts.

A thrombus is not formed from the heated tip. Instead, blood tissue surrounding the tip is coagulated. Coagulation is a denaturation of protein to form a connective-like tissue similar to that which occurs when the albumen of an egg is heated and coagulates from a clear running liquid to an opaque white solid. The tissue characteristics and composition of the coagulated tissue is therefore substantially distinct from the thrombosis which is formed by the thrombotic aggregation of white and red blood cells, platelets and fibrinogen. The coagulative tissue is substantially softer than a thrombotic mass and can therefore more easily be dislodged.

O'Reilly's device depends at least in part upon the successful cauterization timed to occur no later than the detachment of the heat tip from the optic fiber. The heated tip must also be proportionally sized to the neck of the aneurysm in order to effectively coagulate the tissue surrounding it to form a blockage at the neck. It is believed that the tissue in

the interior of the aneurysm remains substantially uncoagulated. In addition, the hot melt adhesive attaching the tip to the optic fiber melts and is dispersed into the adjacent blood tissue where it resolidifies to form free particles within the intracranial blood stream with much the same disadvantages which result from fragmentation of a ferromagnetic electrothrombosis.

Therefore, what is needed is an apparatus and methodology which avoids each of the shortcomings and limitations of the prior art discussed above.

BRIEF SUMMARY OF THE INVENTION

The invention is a method for forming an occlusion within a vascular cavity having blood disposed therein comprising the steps of endovascularly disposing a wire and/or tip near an endovascular opening into the vascular cavity. The wire may include a distinguishable structure at its distal end, which is termed a tip, in which case the remaining portion of the wire may be termed a guidewire. The term "wire" should be understood to collectively include both guidewires and tips and simply wires without distinct tip structures. However, the tip may also simply be the extension of the wire itself without substantial distinction in its nature. A distal tip of the wire is deposited into the vascular cavity to pack the cavity to mechanically form the occlusion within the vascular cavity about the distal tip. The distal tip is detached from the guidewire (or wire) to leave the distal tip within the vascular cavity. As a result, the vascular cavity is occluded by the distal tip, and by any thrombus formed by use of the tip.

In one embodiment, the step of detaching the distal tip from the guidewire (or wire) comprises the step of mechanically detaching the distal tip from the guidewire (or wire).

In another embodiment, the guidewire and tip (or wire) are used within a microcatheter and in the step of detaching the distal tip from the guidewire (or wire), the guidewire and tip (or wire) are longitudinally displaced within the microcatheter. The microcatheter has radio-opaque proximal and tip markers. The guidewire and tip (or wire) have collectively a single radio-opaque marker. The displacement of the guidewire and tip (or wire) moves the single radio-opaque marker to the proximity of the proximal marker on the microcatheter. At this point the tip will be fully deployed in the vascular cavity and tip separation may proceed. It is not necessary then in this embodiment to be able to see actual deployment of the tip before operation. The tip member allows and enhances direct observation of the correct placement of the catheter tip into the opening of the vascular cavity.

In one embodiment the step of disposing the tip (or wire) into the vascular cavity to pack the cavity comprises the step of disposing a tip (or wire) having a plurality of filaments extending therefrom to pack the cavity.

In another embodiment the step of disposing the tip (or wire) into the vascular cavity to pack the cavity comprises the step of disposing a long flexible tip (or wire) folded upon itself a multiple number of times to pack the cavity.

The invention can also be characterized as a method for forming an occlusion within a vascular cavity having blood disposed therein comprising the steps of endovascularly disposing a wire within a microcatheter near an endovascular opening into the vascular cavity. The microcatheter has a distal tip electrode. The distal tip of the wire is disposed into the vascular cavity to pack the cavity to form the occlusion within the vascular cavity about the distal tip of the wire by applying a current between the distal tip electrode and the

5

distal end of the wire packed into the cavity. The distal tip of the wire is detached from the wire to leave the distal tip of the wire within the vascular cavity. As a result, the vascular cavity is occluded by the distal tip, and by any thrombus formed by use of the tip.

The invention is also a wire for use in formation of an occlusion within a vascular cavity used in combination with a microcatheter comprising a core wire, and a detachable elongate tip portion extending the core wire for a predetermined lineal extent. The tip portion is adapted to be packed into the vascular cavity to form the occlusion in the vascular cavity and coupled to the distal portion of the core wire. As a result, endovascular occlusion of the vascular cavity can be performed.

In one embodiment, the elongate tip portion is a long and substantially pliable segment adapted to be multiply folded upon itself to substantially pack said vascular cavity.

In another embodiment, the elongate tip portion is a segment adapted to be disposed in said vascular cavity and having a plurality of filaments extending therefrom to substantially pack said vascular cavity when disposed therein.

In still another embodiment, the microcatheter has a pair of radioopaque markers disposed thereon and the core wire has a radioopaque marker disposed thereon. The marker on the core wire is positioned in the proximity of one of the pair of markers on the microcatheter when the core wire is fully deployed. The other marker on the core wire marks the position of the catheter tip.

The invention is still further characterized as a microcatheter system for use in formation of an occlusion within a vascular cavity comprising a microcatheter having a distal end adapted for disposition in the proximity of the vascular cavity. The distal end has an electrode disposed thereon. A conductive guidewire is disposed in the microcatheter and longitudinally displaceable therein. The guidewire comprises a core wire, and an elongate tip portion extending the core wire for a predetermined lineal extent. The tip portion is adapted to be packed into the vascular cavity to form the occlusion in the vascular cavity. The tip portion is coupled to the distal portion of the core wire. The occlusion is formed by means of applying a current between the tip portion and the electrode on the microcatheter when the tip portion is disposed into the vascular cavity. As a result, endovascular occlusion of the vascular cavity can be performed.

More generally speaking, the invention is a method for forming an occlusion within a vascular cavity having blood disposed therein comprising the steps of disposing a body into the cavity to substantially impede movement of blood in the cavity. The body is employed in the cavity to form the occlusion within the vascular cavity. As a result, the vascular cavity is occluded by the body.

The step of disposing the body in the vascular cavity comprises the step of packing the body to substantially obstruct the cavity.

In one embodiment the step of packing the cavity with the body comprises the step of obstructing the cavity with a detachable elongate wire tip multiply folded upon itself in the cavity.

The step of disposing the body into the vascular cavity comprises disposing in the vascular cavity means for slowing blood movement in the cavity to initiate formation of the occlusion in the cavity.

In another embodiment the step of packing the cavity with the body comprises the step of obstructing the cavity with a body having a compound filamentary shape.

6

The step of employing the blood in the vascular cavity to form the occlusion comprises the step of applying an electrical current to the body or mechanically forming the occlusion in the body or simultaneously.

5 The invention is also wire for use in formation of an occlusion within a vascular cavity used in combination with a microcatheter. The invention comprises a core wire and a detachable elongate tip portion extending the core wire for a predetermined lineal extent. The core wire is adapted to
10 being packed into the vascular cavity to form the occlusion in the vascular cavity and is coupled to the distal portion of the core wire. The tip portion includes a first segment for disposition into the cavity and a second segment for coupling the first portion to the core wire. The second segment is adapted to be electrolyzed upon application of current. An
15 insulating coating is disposed on the first segment. The second segment is left exposed to permit selective electrolysis thereof. As a result, endovascular occlusion of the vascular cavity can be performed.

20 The invention can better be visualized by now turning to the following drawings wherein like elements are referenced by like numerals.

BRIEF DESCRIPTION OF THE DRAWINGS

25 FIG. 1 is an enlarged partially cross-sectioned side view of a first embodiment of the distal end of the guidewire and tip of the invention

30 FIG. 2 is an enlarged longitudinal cross section of a second embodiment of the guidewire and tip of the invention.

FIG. 3 is an enlarged side view of a third embodiment of the invention with a microcatheter portion cut away in a longitudinal cross-sectional view.

35 FIG. 4 is a simplified depiction of the wire of FIG. 3 shown disposed within a simple cranial aneurysm.

FIG. 5 is a depiction of the wire of FIG. 4 shown after electrolytic detachment of the tip.

40 FIG. 6 is plan view of another embodiment of the guidewire and tip portion wherein the type is provided with a plurality of polyester filamentary hairs.

45 FIGS. 7 and 8 are a diagrammatic depictions of the use of the invention wherein position markers have been provided on the catheter and wire to assist in proper fluoroscopic manipulation.

FIG. 9 is a simplified cross-sectional view of the catheter and wire showing a ground electrode disposed on the distal tip of the catheter.

50 The invention and its various embodiments are best understood by now turning to the following detailed description.

DETAILED DESCRIPTION OF THE PREFERRED EMBODIMENTS

55 An artery, vein, aneurysm, vascular malformation or arterial fistula is occluded through endovascular occlusion by the endovascular insertion of a platinum tip into the vascular cavity. The vascular cavity is packed with the tip to obstruct blood flow or access of blood in the cavity such that the
60 blood clots in the cavity and an occlusion is formed. The tip may be elongate and flexible so that it packs the cavity by being folded upon itself a multiple number of times, or may pack the cavity by virtue of a filamentary or fuzzy structure of the tip. The tip is then separated from the wire mechanically or by electrolytic separation of the tip from the wire. The wire and the microcatheter are thereafter removed leaving the tip embedded in the thrombus formed within the

vascular cavity. Movement of wire in the microcatheter is more easily tracked by providing a radioopaque proximal marker on the microcatheter and a corresponding indicator marker on the wire. Electrothrombosis is facilitated by placing the ground electrode on the distal end of the microcatheter and flowing current between the microcatheter electrode and the tip.

When the tip is separated from the wire by electrolytic separation of the tip from the wire, a portion of the wire connected between the tip and the body of the wire is comprised of stainless steel and exposed to the bloodstream so that upon continued application of a positive current to the exposed portion, the exposed portion is corroded away at least at one location and the tip is separated from the body of the wire.

FIG. 1 is an enlarged side view of a first embodiment of the distal end of the wire and tip shown in partial cross-sectional view. A conventional Teflon laminated or similarly insulated stainless steel wire 10 is disposed within a protective microcatheter (not shown). Stainless steel wire 10 is approximately 0.010–0.020 inch (0.254–0.508 mm) in diameter. In the illustrated embodiment, wire 10 is tapered at its distal end to form a conical section 12 which joins a section 14 of reduced diameter which extends longitudinally along a length 16 of wire 10. Section 16 then narrows gradually down to a thin threadlike portion 18 beginning at a first bonding location 20 and ending at a second bonding location 22.

The stainless steel wire 10, comprised of that portion disposed within the microcatheter body, tapered section 12, reduced diameter section 16 and threadlike section 18, is collectively referred to as a core wire which typically is 50–300 cm in length.

In the illustrated embodiment the portion of the core wire extending from tapered section 12 to second bonding location 22 is collectively referred to as the grinding length and may typically be between 20 and 50 cm. in length.

Reduced diameter portion 14 and at least part of sections 12 and first bonding location 20 may be covered with an insulating Teflon laminate 24 which encapsulates the underlying portion of wire 10 to prevent contact with the blood.

A stainless steel coil 26 is soldered to the proximate end of threadlike portion 18 of wire 10 at first bonding location 20. Stainless steel coil 26 is typically 3 to 10 cm. in length and like wire 10 has a diameter typically between 0.010 to 0.020 inch (0.254–0.508 mm).

The distal end of stainless steel coil 26 is soldered to the distal end of threadlike portion 18 of wire 10 and to the proximal end of a platinum secondary coil 28 at second bonding location 22. Secondary coil 28 itself forms a spiral or helix typically between 2 to 10 mm in diameter. The helical envelope formed by secondary coil 28 may be cylindrical or conical. Like wire 10 and stainless steel coil 26, a secondary coil 28 is between approximately 0.010 and 0.020 inch (0.254–0.508 mm) in diameter. The diameter of the wire itself forming stainless steel coil 26 and coil 28 is approximately between 0.001–0.005 inch.

The distal end of secondary coil 28 is provided with a platinum soldered tip 30 to form a rounded and smooth termination to avoid puncturing the aneurysm or tearing tissue.

Although prebiased to form a cylindrical or conical envelope, secondary coil 28 is extremely soft and its overall shape is easily deformed. When inserted within the microcatheter (not shown), secondary coil 28 is easily straightened to lie axially within the microcatheter. Once disposed out of the tip of the microcatheter, secondary coil 28 formed the

shape shown in FIG. 1 and may similarly be loosely deformed to the interior shape of the aneurysm.

As will be described below in greater detail in connection with the third embodiment of FIG. 3, after placement of secondary coil 28 within the interior of the aneurysm a direct current is applied to wire 10 from a voltage source exterior to the body. The positive cleavage on secondary coil 28 within the cavity of the aneurysm causes a thrombus to form within the aneurysm by electrothrombosis. Detachment of the tip occurs either: (1) by continued application of current for a predetermined time when the portion 18 is exposed to blood; or (2) by movement of the wire to expose portion 18 to blood followed by continued current application for a predetermined time. Ultimately, both threadlike portion and stainless steel coil 26 will be completely disintegrated at least at one point, thereby allowing wire 10 to be withdrawn from the vascular space while leaving secondary coil 28 embedded within the thrombus formed within the aneurysm.

FIG. 2 illustrates in enlarged partially cross-sectional view a second embodiment of the invention. Stainless steel core 32 terminates in a conical distal portion 34. Stainless steel coil 36, shown in cross-sectional view, is soldered to distal portion 34 of wire 32 at bonding location 38. The opposing end of the stainless steel coil 36 is provided with a soldered, rounded platinum tip 40. In the illustrated embodiment, stainless steel core wire 32 is approximately 0.010 inch in diameter with the length of stainless steel coil 36 being approximately 8 cm. with the longitudinal length of platinum tip 40 being between 3 and 10 mm. The total length of wire 32 from tip 40 to the proximal end is approximately 150 cm.

The embodiment of FIG. 2 is utilized in exactly the same manner as described above in connection with FIG. 1 to form a thrombic mass within an aneurysm or other vascular cavity. The embodiment of FIG. 2 is distinguished from that shown in FIG. 1 by the absence of the extension of stainless core 32 through coil 36 to tip 44. In the case of the embodiment of FIG. 2 no inner core or reinforcement is provided within stainless steel coil 36. Threadlike portion 18 is provided in the embodiment of FIG. 1 to allow increased tensile strength of the wire. However, a degree of flexibility of the wire is sacrificed by the inclusion even of threadlike tip 18, so that the embodiment of FIG. 2 provides a more flexible tip, at least for that portion of micro-guidewire constituting the stainless steel coil 36.

It is expressly understood that the helical secondary coil tip of the embodiment of FIG. 1 could similarly be attached to stainless steel coil 36 of the embodiment of FIG. 2 without departing from the spirit and scope of the invention.

Thinned and threadlike portion guidewires disposed concentrically within coiled portions are well known and are shown in Antoshkiw, "Disposable Guidewire", U.S. Pat. No. 3,789,841 (1974); Sepetka et al., "Guidewire Device", U.S. Pat. No. 4,832,047 (1989); Engleson, "Catheter Guidewire", U.S. Pat. No. 4,884,579 (1989); Samson et al., "Guidewire for Catheters", U.S. Pat. No. 4,538,622 (1985); and Samson et al., "Catheter Guidewire with Short Spring Tip and Method of Using the Same". U.S. Pat. No. 4,554,929 (1985).

Turn now to the third embodiment of the invention as shown in FIG. 3. FIG. 3 shows an enlarged side view of a wire, generally denoted by reference numeral 42, disposed within a microcatheter 44 shown in cross-sectional view. Like the embodiment of FIG. 1, a stainless steel coil 46 is soldered to a conical portion 48 of wire 42 at a first bonding location 50. A thin threadlike extension 52 is then longitudinally disposed within stainless steel coil 46 to a second

bonding location **54** where stainless steel wire **46** and threadlike portion **52** are soldered to a soft platinum coil **56**. Platinum coil **56** is not prebiased, nor does it contain any internal reinforcement, but is a free end and open coil similar in that respect to stainless steel coil **36** of the embodiment of FIG. 2.

However, platinum coil **56** is particularly distinguished by its length of approximately 1 to 50 cm. and by its flexibility. The platinum or platinum alloy used is particularly pliable and the diameter of the wire used to form platinum coil **56** is approximately 0.001–0.005 inch in diameter. The distal end of platinum coil **56** is provided with a smooth and rounded platinum tip **58** similar in that respect to tips **30** and **40** of FIGS. 1 and 2, respectively.

When coil **56** is disposed within microcatheter **44**, it lies along the longitudinal lumen **60** defined by microcatheter **44**. The distal end **62** of microcatheter **60** is then placed into the neck of the aneurysm and the wire **42** is advanced, thereby feeding tip **58** in platinum coil **56** into aneurysm **64** until bonding location **50** resides in the neck of the aneurysm as best depicted in the diagrammatic cross-sectional view of FIG. 4.

FIG. 4 illustrates the insertion of the embodiment of FIG. 3 within a vessel **66** with distal tip of microcatheter **44** positioned near neck **68** of aneurysm **64**. Coil **56** is fed into aneurysm **64** until at least a portion of stainless steel coil **46** is exposed beyond the distal tip **62** of microcatheter **44**. A positive electric current of approximately 0.01 to 2 milliamps at 0.1–6 volts is applied to wire **42** to form the thrombus. Typically a thrombus will form within three to five minutes. The negative pole **72** of voltage source **70** is typically placed over and in contact with the skin.

After the thrombus has been formed and the aneurysm completely occluded, tip **58** and coil **56** are detached from wire **42** by electrolytic disintegration of at least one portion of stainless steel coil **46**. In the illustrated embodiment this is accomplished by continued application of current until the total time of current application is almost approximately four minutes.

At least one portion of stainless steel coil **46** will be completely dissolved through by electrolytic action within 3 to 10 minutes, usually about 4 minutes. After separation by electrolytic disintegration, wire **42**, microcatheter **44** and the remaining portion of coil **46** still attached to wire **42** are removed from vessel **66**, leaving aneurysm **64** completely occluded as diagrammatically depicted in FIG. 5 by thrombus **74**. It will be appreciated that the time of disintegration may be varied by altering the dimensions of the portions of the wire and/or the current

The process is practiced under fluoroscopic control with local anesthesia at the groin. A transfemoral microcatheter is utilized to treat the cerebral aneurysm. The platinum is not affected by electrolysis and the remaining portions of the microcatheter are insulated either by a Teflon lamination directly on wire **42** and/or by microcatheter **44**. Only the exposed portion of the wire **46** is affected by the electrolysis.

It has further been discovered that thrombus **74** continues to form even after detachment from wire **42**. It is believed that a positive charge is retained on or near coil **56** which therefore continues to attract platelets, white blood cells, red blood cells and fibrinogen within aneurysm **64**.

Although the foregoing embodiment has been described as forming an occlusion within a blood-filled vascular cavity by means of electrothrombosis, the above disclosure must be read to expressly include formation of the occlusion by mechanical mechanisms without resort to the application of

electrical current. A mechanical mechanism which can be safely disposed into the vascular cavity to impede, slow or otherwise initiate clotting of the blood or formation of the occlusion is within the scope of the invention. The insertion within the vascular cavity and maintenance therein of an object with an appropriate blood-clotting characteristics can and does in many cases cause the formation of an occlusion by itself. Depicted in FIG. 6 is an embodiment of the invention wherein such mechanical thrombosis can be achieved. Wire **10** has a tapering end portion **14** covered with a Teflon laminate **24** similar to that described in connection with the embodiment of FIG. 1. Wire **10** is attached by means of a mechanical coupling **100** to a platinum coil **102** which has a plurality of filaments or fine hairs **104** extending therefrom. In the illustrated embodiment, hairs **104** have a length as may be determined from the size of the vascular cavity in which coil **102** is to be used. For example, in a small vessel hair lengths of up to 1 mm are contemplated. An example of polyester filaments or hairs attached to a coil which was not used in electrothrombosis may be seen in the copending application entitled Vasoocclusion Coil with Attached Fibrous Elements, filed Oct. 2, 1991, Ser. No. 07/771,013.

Coil **102** has sufficient length and flexibility that it can be inserted or coiled loosely into the vascular cavity. The length of coil **102** need not be so long that the coil itself is capable of being multiply folded on itself and fill or substantially fill the vascular cavity. Hairs **104** extending from coil **102** serve to substantially pack, fill or at least impede blood flow or access in the vascular cavity. Hairs **104**, which are generally inclined backwardly away from extreme tip **106** when delivered, are thus easily able to slide forward with little friction through restrictions in the vessels and aneurysm. Additionally, hairs **104** do not have sufficient length, strength or sharpness to provide any substantial risk or potential for a puncture of the thin vascular wall. The plurality of hairs **104**, when coiled within the vascular cavity, provide an extremely large surface for attachment of blood constituents to encourage and enhance the formation of a mechanical occlusion within the vascular opening.

In the preferred embodiment, coil **102** is mechanically coupled to thin tapered portion **104** of wire **10** by means of a small drop of polyester **100**. Polyester may be substituted for the gold solder of the previously described embodiments in order to reduce concern or risk of toxic reactions in the body.

Tip portion **104** may also be mechanically separated from wire **10** by means other than electrolysis. One method is make the connection between tip **104** and wire **10** by means of a spring loaded mechanical clasp (not shown). The clasps are retained on tip **104** as long as the clasps remain inside of the catheter, but spring open and release tip **104** when extended from the catheter. The catheter and clasps may then be removed from the insertion site. This type of mechanical connection is described in the copending application entitled, "Detachable Pusher-Vasoocclusive Coil Assembly with Interlocking Coupling", filed Dec. 12, 1991 with Ser. No. 07/806,979 which is incorporated herein by reference and assigned to Target Therapeutics Inc. An alternative non-resilient mechanical ball and clasp capturing mechanism is described in the copending application entitled "Detachable Pusher-Vasoocclusive Coil Assembly with Interlocking Ball and Keyway Coupling", filed Dec. 12, 1991 with Ser. No. 07/806,912 which is also incorporated herein by reference and assigned to Target Therapeutics Inc.

In another embodiment wire **10** and tip portion **104** screw into each other and can be unscrewed from each other by rotation of the catheter or wire with respect to tip **104**. An extendable sheath (not shown) in the microcatheter is

advanced to seize tip **104** to prevent its rotation with wire **10** during the unscrewing process. This type of mechanical connection is described in the copending application entitled "Detachable Pusher-Vasocclusive Coil Assembly with Threaded Coupling", filed Dec. 12, 1991 with Ser. No. 07/806,898 which is incorporated herein by reference and assigned to Target Therapeutics Inc.

In any case the specific means disclosed here of mechanically detaching tip **104** from wire **10** forms no part of the present invention apart from its combination as a whole with other elements of the invention. Specific disclosure of the mechanical means of detachment have been set forth only for the purposes of providing an enabling disclosure of the best mode presently known for practicing the claimed invention.

Even where the occlusion is not formed by electrothrombosis, separation of tip **104** may be effected by electrolysis. In such situations, the electrolyzing current may be concentrated on the sacrificial stainless steel portion of tip **104** by disposition of an insulative coating on the remaining platinum portion. For example, tip **104** may be provided with a polyethylene coating save at least a portion of the stainless length. This has the effect of decreasing the time required to electrolytically sufficiently disintegrate the steel portion to allow detachment of the platinum tip, which is an advantageous feature in those cases where a large aneurysm must be treated and a multiple number of coils must be deployed within the aneurysm.

Notwithstanding the fact that wire **10** and platinum coil **102** in the embodiment FIG. **6** or wire **10** and platinum coil **28**, **36** and **56** in the embodiments of FIGS. **1-5** are radiopaque, there is still some difficulty when manipulating the device under fluoroscopy to be able to determine the exact position or movement of the probe relative to the aneurysm. This is particularly true when a large number of coils are deployed and one coil then radiographically hides another. FIG. **7** illustrates an improvement of, for example, the embodiment of FIGS. **4** and **5**. Microcatheter **144** is positioned so that its distal end **162** within vessel **66** is positioned at the opening aneurysm **64**. Microcatheter **144** is provided with radiopaque marker **108** at distal tip **162**, a tip marker. Moving toward the proximal end of microcatheter **144** is a second radiopaque marker **110**, a proximal marker. Radiopaque markers **108** and **110** are, for example, in the form of radiopaque rings made of platinum, approximately 1-3 mm in longitudinal length along the axis of microcatheter **144**. Rings **110** and **108** are typically separated by about 3 cm on microcatheter **144**. Similarly, wire **10** has a radiopaque marker **112** defined on it such that marker **112** on wire **10** is approximately with aligned with marker **110** on microcatheter **14** when coil **56** is fully deployed into aneurysm **64**. Typically, full deployment will place the solder or connection point **54** of the order of 2-3 mm past opening **68** of aneurysm **64**. Distal marker **108** on microcatheter **144** is used to facilitate the location of the microcatheter tip, which can often be obscured by the coils which have been previously deployed. The coils are a varying lengths depending on the application or size of the aneurysm or vascular cavity being treated. Coil lengths of 4-40 cm are common. Therefore, even though the thinness of coil **56** may make it difficult to see under standard fluoroscopy and even though the fineness of wire **10** may similarly be obscured or partly obscured, radiopaque markers **108**, **110** and **112** are clearly visible. Manipulation of wire **10** to proximal marker **110** can then easily be observed under conventional fluoroscopy even when there are some loss of resolution or fluoroscopic visual obstruction of the coil.

Further, in the previous embodiments, such as that shown in FIGS. **4** and **5**, when electrothrombosis is used to form the occlusion within aneurysm **64**, coil **56** is used as the electrical anode while the cathode is a large skin electrode **72** typically conductively applied to the groin or scalp. FIG. **9** illustrates an alternative embodiment wherein microcatheter **144** is supplied with an end electrode **114** coupled to an electrical conductor **116** disposed along the length of microcatheter **144**. Wire **116** is ultimately led back to voltage source **70** so that ring electrode **114** is used as the cathode during electrothrombosis instead of an exterior skin electrode **72**. With the embodiment of FIG. **9** the electrical currents and electrical current paths which are set up during the electrothrombosis formation are local to the site of application which allows even smaller currents and voltages to be used to initiate electrothrombosis than in the situation when an exterior skin electrode must be utilized. The electrothrombotic current distributions are also better controlled and localized to the site of the thrombus formation. The possibility of stray thrombus formations occurring at unwanted sites or uncontrolled and possibly unwanted electrical current patterns being established elsewhere in the brain or body is therefor largely avoided.

Many alterations and modifications may be made by those having ordinary skill in the art without departing from the spirit and scope of the invention. Therefore, it must be understood that the shape of the tip or distal platinum coil used in combination with the wire according to the invention may be provided with a variety of shapes and envelopes. In addition thereto, the composition of the micro-guidewire tip may be made of elements other than platinum including stainless steel beryllium, copper and various alloys of the same with or without platinum. Still further, the diameter of the wire, various of the wire described above and the stainless steel coil immediately proximal to the detachable tip may be provided with differing diameters or cross sections to vary the times and current magnitudes necessary in order to effectuate electrolytic detachment from the tip. Still further, the invention may include conventional electronics connected to the proximal end of the wire for determining the exact instant of detachment of the distal tip from the wire.

Therefore, the illustrated embodiment has been set forth only for the purposes of clarity and example and should not be taken as limiting the invention as defined by the following claims, which include all equivalent means whether now known or later devised.

We claim:

1. An apparatus adapted to form an occlusion within a body cavity having fluid disposed therein comprising:

a wire; and

a separable distal tip section adapted to be disposed into said body cavity to substantially space occupy said body cavity to mechanically form said occlusion within said body cavity about and separable distal tip section wherein mechanically forming an occlusion is defined as forming an occlusion so that fluid flow is substantially inhibited, said separable distal tip being adapted to be nonthermally separated from said wire to leave said separable distal tip section within said body cavity, wherein nonthermal separation is defined as a detachment without substantially increasing the temperature of said distal tip section, wherein said separable distal tip section is separated from said wire without necessarily displacing said distal tip section therefrom, wherein said separable distal tip section has no memory of its predisposed shape other than at most a relaxed simple helical shape.

13

whereby said body cavity is occluded by said distal tip section, and any thrombus formed by used of said distal tip section.

2. The apparatus of claim 1 wherein said separable distal tip section is mechanically detachable from said wire.

3. The apparatus of claim 1 further comprising a catheter and where said wire and distal tip section are longitudinally displaced within said catheter, said catheter having a radioopaque proximal marker, said wire and distal tip section having collectively a single radioopaque marker, said displacement of said wire and distal tip section moving said single radioopaque marker to the proximity of said proximal marker on said catheter when said distal tip section is fully deployed in said cavity.

4. The apparatus of claim 1 where said distal tip section comprises a long flexible distal tip section having a plurality of filaments extending therefrom to pack said body cavity.

5. The apparatus of claim 1 where said distal tip section is sufficiently long and flexible to fold upon itself a multiple number of times to occupy said body cavity to substantially impede fluid flow therein.

6. An apparatus for forming an occlusion in a body cavity comprising:

a microcatheter having a distal electrode;

a wire having a distal tip;

a distal tip electrode on said wire, said distal tip of said wire for substantially space filling said cavity to form said occlusion about said distal tip by application of a current between said distal tip electrode on said wire and said distal electrode on said microcatheter; and

a nonthermal detachment coupling between said distal tip of said wire and a remaining portion of said wire, wherein nonthermal detachment is defined as a detachment without substantially increasing the temperature of said detachment coupling.

whereby said cavity is occluded by said distal tip and a thrombus formed thereby.

7. An apparatus for use in occluding a body cavity comprising:

a wire; and

a detachable elongate distal tip coupled to said wire, said elongate distal tip being a relaxed coil capable of being multiply folded upon itself.

8. The improvement of claim 7 wherein said elongate distal tip is a long and substantially pliable segment adapted to be multiply folded upon itself to sufficiently occupy said body cavity to impede the fluid flow therein.

9. The improvement of claim 7 wherein said elongate tip is a segment adapted to be disposed in said body cavity and has a plurality of filaments extending therefrom to sufficiently occupy said body cavity to impede fluid flow therein.

10. The improvement of claim 7 further comprising a catheter having a pair of radioopaque markers disposed thereon and having a distal end, said wire having a radioopaque marker disposed thereon, said marker on said wire being positioned in the proximity of one of said pair of markers on said catheter when said wire is fully deployed in said body cavity, said other marker of said pair of markers on said catheter indicating said distal end of said catheter.

11. The improvement of claim 7 wherein said distal tip is coupled to said wire by a polymeric bead.

12. The improvement of claim 11 wherein said bead is polyester.

13. The apparatus of claim 7 wherein said detectable elongate tip is a coil having a length between 1 and 50 cm.

14. An apparatus for forming an occlusion within a body cavity having fluid disposed therein comprising:

14

a catheter having a distal end for disposition in proximity to said cavity and having an electrode disposed therein; a conductive wire disposed in said catheter and longitudinally displaceable therein, said wire comprising:

a core wire having a distal portion; and

an elongate tip portion extending from said core wire for a predetermined lineal extent and adapted to being packed into said cavity and coupled to said distal portion of said core wire, said occlusion being formed by means of application of a current between said elongate tip portion and said electrode on said catheter when said elongate tip portion is disposed in said cavity, said elongate tip portion being a relaxed coil having no substantial memory of its predisposed shape other than at most a relaxed simple helical shape,

wherein occlusion of said cavity is performed.

15. In an apparatus having a wire for forming an occlusion in a body cavity having a fluid flowing therein, the improvement comprising:

a deformable object temporarily coupled to said wire for disposition into said cavity having no preferred geometric form when disposed into said cavity, said deformable object capable of being multiply folded upon itself, said deformable object substantially impeding movement of said fluid in said cavity to thereby form said occlusion,

whereby said cavity is occluded by said object.

16. The improvement of claim 15 where said deformable object is adapted to being packed into said body cavity to substantially obstruct said cavity.

17. The improvement of claim 16 where said object comprises a detachable, elongate, coil wire tip which is capable of being multiply folded upon itself in said body cavity.

18. The improvement of claim 16 wherein said deformable object has a multiplicity of flexible filaments extending therefrom.

19. The improvement of claim 15 wherein said deformable object comprises a means for slowing fluid movement in said cavity to initiate formation of said occlusion in said cavity.

20. The improvement of claim 15 further comprising a source of electrical current coupling to said deformable object and wherein said occlusion is formed by application of current to said deformable object.

21. The improvement of claim 20 further comprising a catheter and a proximal electrode on said catheter used to dispose said deformable object into said cavity, said current being applied by said means between said deformable object and said proximal electrode.

22. The improvement of claim 15 where said deformable object is adapted to mechanically form said occlusion within said cavity.

23. The improvement of claim 15 further comprising a source of electrical current coupling to said deformable object, wherein said occlusion is simultaneously formed by application of current to said deformable object and wherein said occlusion is mechanically formed by said deformable object within said cavity.

24. An apparatus adapted to form an occlusion within a body cavity used in combination with a catheter comprising:

a wire;

a detachable elongate distal tip portion coupled to and extending from said wire for a predetermined lineal extent, said detachable elongate distal tip portion being adapted to being packed into said body cavity to form

15

said occlusion in said body cavity, said elongate distal tip portion including a first flexible, shapeless segment having substantially no memory of its predisposition shape other than at most a relaxed, simple helical shape for disposing into said cavity and a second segment for coupling said first segment to said wire, said second segment being adapted to be electrolyzed upon application of current; and

an insulating coating disposed on said first segment, said second segment being left exposed to permit selective electrolysis thereof,

whereby occlusion of said body cavity is achieved.

25. An apparatus adapted to form an occlusion within a body cavity having fluid disposed therein comprising:

a wire adapted for disposition near an opening into said body cavity;

a distal tip coupled to said wire adapted to substantially occupy said body cavity to form said occlusion within said body cavity about said distal tip, said distal tip being characterized by being adapted to carry electrical current therethrough to form an electrothrombosis in said body cavity, and being mechanically detachable from said wire to leave said distal tip within said body cavity,

whereby said body cavity is occluded by said distal tip, and any thrombus formed by use of said distal tip.

26. A method for forming an occlusion within a body cavity having fluid disposed therein comprising the steps of:

disposing a relaxed wire into said body cavity, said relaxed wire having no substantial memory of its predisposed shape other than at most a relaxed, simple helical shape;

disposing a separable distal tip of said relaxed wire to substantially space occupy said body cavity to mechanically form said occlusion within said body cavity about said separable distal tip; and

nonthermally detaching said separable distal tip from said wire without necessarily displacing said distal tip from said wire in order to detach said distal tip from said wire, wherein nonthermal detachment is defined as a detachment without substantially increasing the temperature of a coupling between said distal tip and wire, whereby said body cavity is occluded by said distal tip, and a thrombus formed by use of said tip.

27. The method of claim **26** wherein said step of detaching a separate distal tip of said relaxed wire mechanically detaches said distal tip from said wire.

28. The method of claim **26** where said wire and tip are used with a catheter, and were in said step of nonthermally detaching said distal tip from said wire, said wire and tip are longitudinally displaced within said catheter, said catheter having a radioopaque proximal marker, said wire and tip having collectively a single radioopaque marker, said displacement of said wire and tip moving said single radioopaque marker to the proximity of said proximal marker on said catheter when said tip is fully deployed in said cavity.

29. The method of claim **26** where said step of disposing said top comprises disposing a long flexible tip having a plurality of filaments extending therefrom to pack said body cavity.

30. The method of claim **26** where said step of disposing a relaxed wire into said body cavity disposes a long and flexible coil which folds upon itself a multiple number of times to occupy said body cavity to substantially impede fluid flow therein.

16

31. A method for forming an occlusion in a body cavity comprising:

disposing a microcatheter having a distal electrode near an opening into said body cavity;

disposing a wire having a distal tip electrode into said body cavity to substantially fill said cavity to form said occlusion about said distal tip electrode by application of a current between said distal tip electrode on said wire and said distal electrode on said microcatheter; and

nonthermally detaching a distal tip of said wire from a remaining portion of said wire, wherein said distal tip is coupled to said remaining portion by a detachment coupling and wherein nonthermal detachment is defined as a detachment without substantially increasing the temperature of said detachment coupling,

whereby said cavity is occluded by said distal tip and a thrombus formed thereby.

32. A method of forming an occlusion within a body cavity used in combination with a wire comprising the step of:

packing at least one detachable elongate distal tip portion coupled to and extending from said wire for a predetermined lineal extent into said body cavity to form said occlusion in said body cavity, said elongate distal tip portion being a relaxed coil capable of being multiply folded upon itself; and

detaching said elongate distal tip portion from said wire, whereby occlusion of said body cavity is achieved.

33. The wire of claim **32** where said step of packing at least one detachable elongate distal tip into said body cavity packs a long and substantially pliable segment adapted to be multiply folded upon itself to sufficiently occupy said body cavity to impede fluid flow therein.

34. The method of claim **32** wherein said step of packing said elongate tip portion packs a segment in said body cavity having a plurality of filaments extending therefrom to sufficiently occupy said body cavity to impede fluid flow therein.

35. The method of claim **32** further comprising the step of disposing said wire into a catheter having a pair of radioopaque markers disposed thereon and having a distal end, said wire having a radioopaque marker disposed thereon, said marker on said wire being positioned in the proximity of one of said pair of markers on said catheter when said wire is fully deployed in said body cavity and said other marker of said pair of markers on said catheter indicating said distal end of said catheter during said step of packing.

36. The wire of claim **32** where in said step of packing said distal tip portion is coupled to said wire by a polyester bead.

37. A method for forming an occlusion within a body cavity having fluid disposed therein comprising the steps of:

disposing a catheter having an electrode disposed thereon and having a distal end in proximity to said cavity;

disposing a conductive wire in said catheter and longitudinally displaceable therein, said wire comprising a core wire having a distal portion;

and an elongate tip portion extending from said core wire for a predetermined lineal extent and coupled to said distal portion of said core wire;

packing said elongate tip portion into said cavity;

forming said occlusion by means of application of a current between said elongate tip portion and said electrode on said catheter when said elongate tip portion is disposed in said cavity, said elongate tip portion being a

17

relaxed coil having no substantial memory of its predisposed shape other than at most a relaxed simple helical shape,

whereby occlusion of said cavity is performed.

38. In a method for forming an occlusion in a body cavity having a fluid flowing therein by disposing a wire at least adjacent to said body cavity, the improvement comprising:

disposing a deformable object into said cavity having no preferred geometric form when disposed into said cavity, said deformable object capable of being multiply folded upon itself, said deformable object substantially impeding movement of said fluid in said cavity to thereby form said occlusion, whereby said cavity is occluded by said object.

39. The method of claim **38** where said step of disposing said deformable object packs said deformable object into said body cavity to substantially obstruct said cavity.

40. The improvement of claim **39** where said step of disposing said deformable object packs said object into said cavity by disposition of a detachable, elongate, coil wire tip which is multiply folded upon itself in said body cavity.

41. The improvement of claim **39** where said step of disposing said deformable object packs said deformable object having a multiplicity of flexible filaments extending therefrom into said cavity.

42. The improvement of claim **38** where said step of disposing said deformable object comprises the step of slowing fluid movement in said cavity to initiate formation of said occlusion in said cavity.

43. The improvement of claim **38** in combination with a catheter having a proximal electrode and used to dispose said deformable object into said cavity, and further comprising the step of applying electrical current to said deformable object and wherein said occlusion is formed by application of current between said deformable object and said proximal electrode.

44. The improvement of claim **38** where disposing a deformable object into said cavity mechanically forms said occlusion within said cavity.

18

45. The improvement of claim **38** further comprising a source of electrical current coupling to said deformable object, where disposing a deformable object into said cavity mechanically forms said occlusion within said cavity and where said occlusion is simultaneously formed by application of current to said deformable object from said electrical source.

46. A method for forming an occlusion within a body cavity in combination with a catheter comprising:

packing a detachable elongate distal tip portion coupled to and extending from a wire into said body cavity to form said occlusion in said body cavity, said elongate distal tip portion including a first flexible, shapeless segment having substantially no memory of its predisposition shape other than at most a relaxed, simple helical shape for disposition into said cavity and a second segment for coupling said first segment to said wire; and

electrolytically disconnecting said second segment from said wire upon application of current to said second segment, an insulating coating disposed on said first segment, said second segment being left exposed to permit selective electrolysis thereof,

whereby occlusion of said body cavity is achieved.

47. A method for forming an occlusion within a body cavity having fluid disposed therein comprising:

disposing a wire near an opening into said body cavity; disposing a distal tip coupled to said wire into said body cavity to substantially occupy said body cavity to form said occlusion within said body cavity about said distal tip;

forming an electrothrombosis in said body cavity about said distal tip being by applying electrical current said distal tip; and

mechanically detaching said distal tip from said wire to leave said distal tip within said body cavity,

whereby said body cavity is occluded by said distal tip, and any thrombus formed by use of said distal tip.

* * * * *