

US00RE40900E

(19) **United States**
(12) **Reissued Patent**
Forster

(10) **Patent Number:** **US RE40,900 E**
(45) **Date of Reissued Patent:** ***Sep. 1, 2009**

(54) **AMPLIFIER CIRCUIT**

(76) Inventor: **Ian J. Forster**, 31 Great Cob,
Chelmsford, Essex (GB), CM1 6LA

(*) Notice: This patent is subject to a terminal disclaimer.

(21) Appl. No.: **11/541,516**

(22) PCT Filed: **May 17, 2000**

(86) PCT No.: **PCT/GB00/01895**

§ 371 (c)(1),
(2), (4) Date: **Mar. 12, 2002**

(87) PCT Pub. No.: **WO00/72440**

PCT Pub. Date: **Nov. 30, 2000**

Related U.S. Patent Documents

Reissue of:

(64) Patent No.: **6,799,027**
Issued: **Sep. 28, 2004**
Appl. No.: **09/926,572**
Filed: **Mar. 12, 2002**

(30) **Foreign Application Priority Data**

May 22, 1999 (GB) 9911880.4

(51) **Int. Cl.**
H03F 3/60 (2006.01)
H04B 1/26 (2006.01)

(52) **U.S. Cl.** **455/313; 455/106; 455/311;**
455/325; 455/341; 330/287

(58) **Field of Classification Search** ... **455/232.1–253.2,**
455/307, 334, 313, 325, 311, 341, 106, 222.1,
455/47, 22, 104, 109, 339, 19, 7, 319, 126,
455/127.1–127.5; 330/287, 51, 107, 61 A,
330/174

See application file for complete search history.

(56) **References Cited**

U.S. PATENT DOCUMENTS

3,633,134	A	1/1972	Barrows	
3,646,467	A	* 2/1972	Smith	330/287
3,663,886	A	5/1972	Blume	
3,699,454	A	10/1972	Hudspeth	
3,911,365	A	10/1975	Maurer	
4,080,602	A	* 3/1978	Hattori et al.	340/825.72
4,086,543	A	4/1978	Nigrin	
4,150,382	A	4/1979	King	
4,358,763	A	11/1982	Strauch	

(Continued)

FOREIGN PATENT DOCUMENTS

JP	55105408	A	8/1980
JP	355105408	A	* 8/1980
JP	55137707	A	10/1980
JP	60127806	A	7/1985

Primary Examiner—Lana N. Le

(74) *Attorney, Agent, or Firm*—Christensen O'Connor Johnson Kindness PLLC

(57) **ABSTRACT**

An amplifier circuit for amplifying an input signal to generate an amplifier output signal incorporates a cascaded series of reflection amplifiers arranged along a signal path and operative to amplify signals propagating in a forward direction along the signal path. The circuit is operative to counteract signal propagation in a reverse direction along the signal path, thereby hindering spontaneous oscillation from arising within the circuit. Incorporation of reflection amplifiers into the circuit enables it to provide high gain, for example 50 dB, while consuming low currents, for example, tens of microamperes. The circuit is especially suitable for use at intermediate frequencies in radio receivers such as mobile telephones.

68 Claims, 3 Drawing Sheets

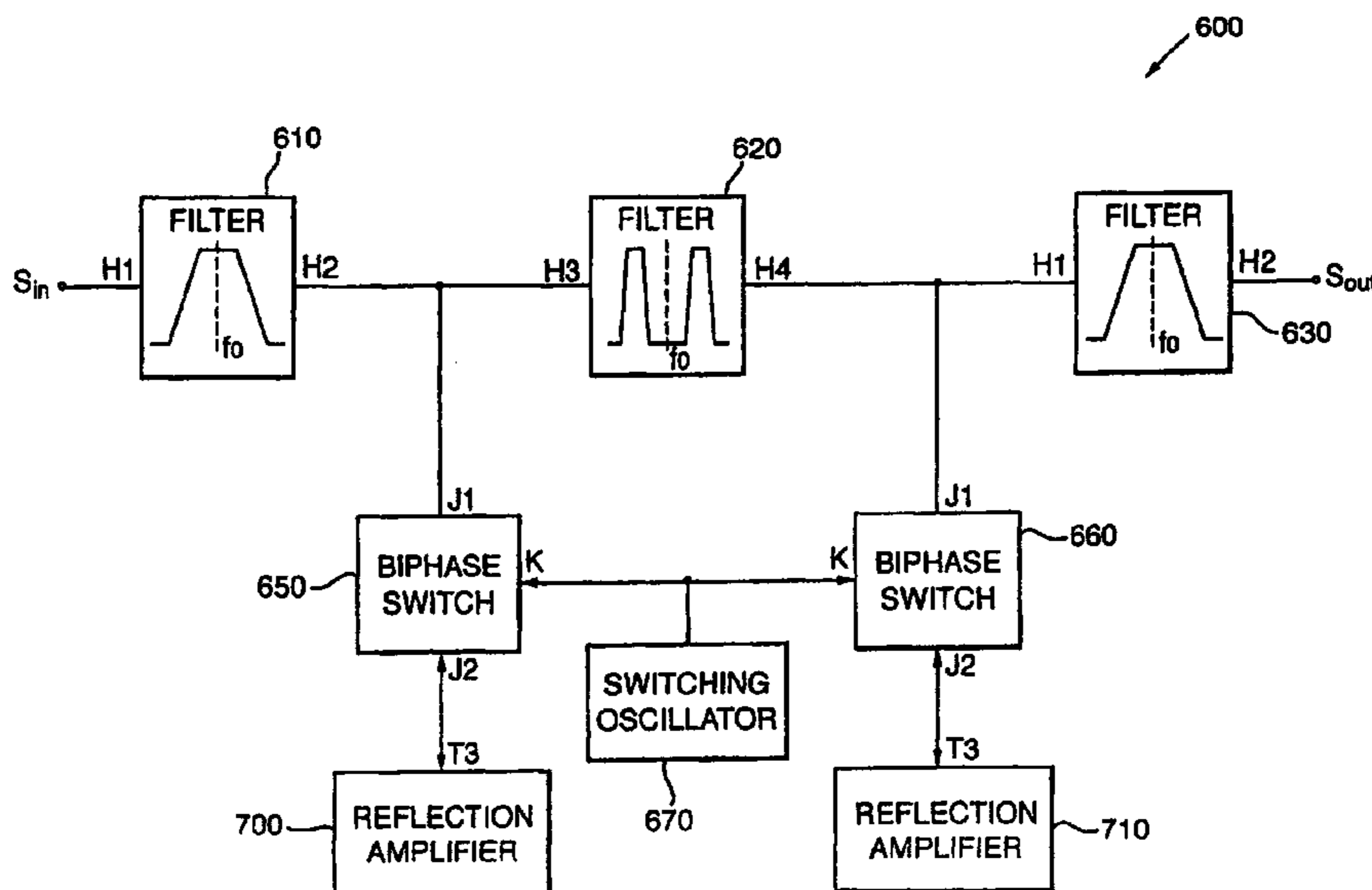

US RE40,900 E

Page 2

U.S. PATENT DOCUMENTS

4,584,504	A	*	4/1986	Lee et al.	340/825.69	5,822,685	A	10/1998	Forster		
4,764,979	A		8/1988	Noguchi		5,901,347	A	*	5/1999	Chambers et al. 455/234.1	
5,121,077	A	*	6/1992	McGann	455/126	5,987,304	A	*	11/1999	Latt	455/17
5,170,495	A	*	12/1992	McNicol et al.	455/126	6,041,082	A	*	3/2000	Takeda et al.	455/108
5,237,288	A	*	8/1993	Cleveland	455/114.2	6,070,063	A		5/2000	Yoshizawa	
5,305,109	A	*	4/1994	Harford	455/253.2	6,072,824	A		6/2000	Huang	
5,493,719	A	*	2/1996	Smith et al.	455/325	6,369,772	B1		4/2002	Forster	
						6,480,062	B1	*	11/2002	Forster	330/51

* cited by examiner

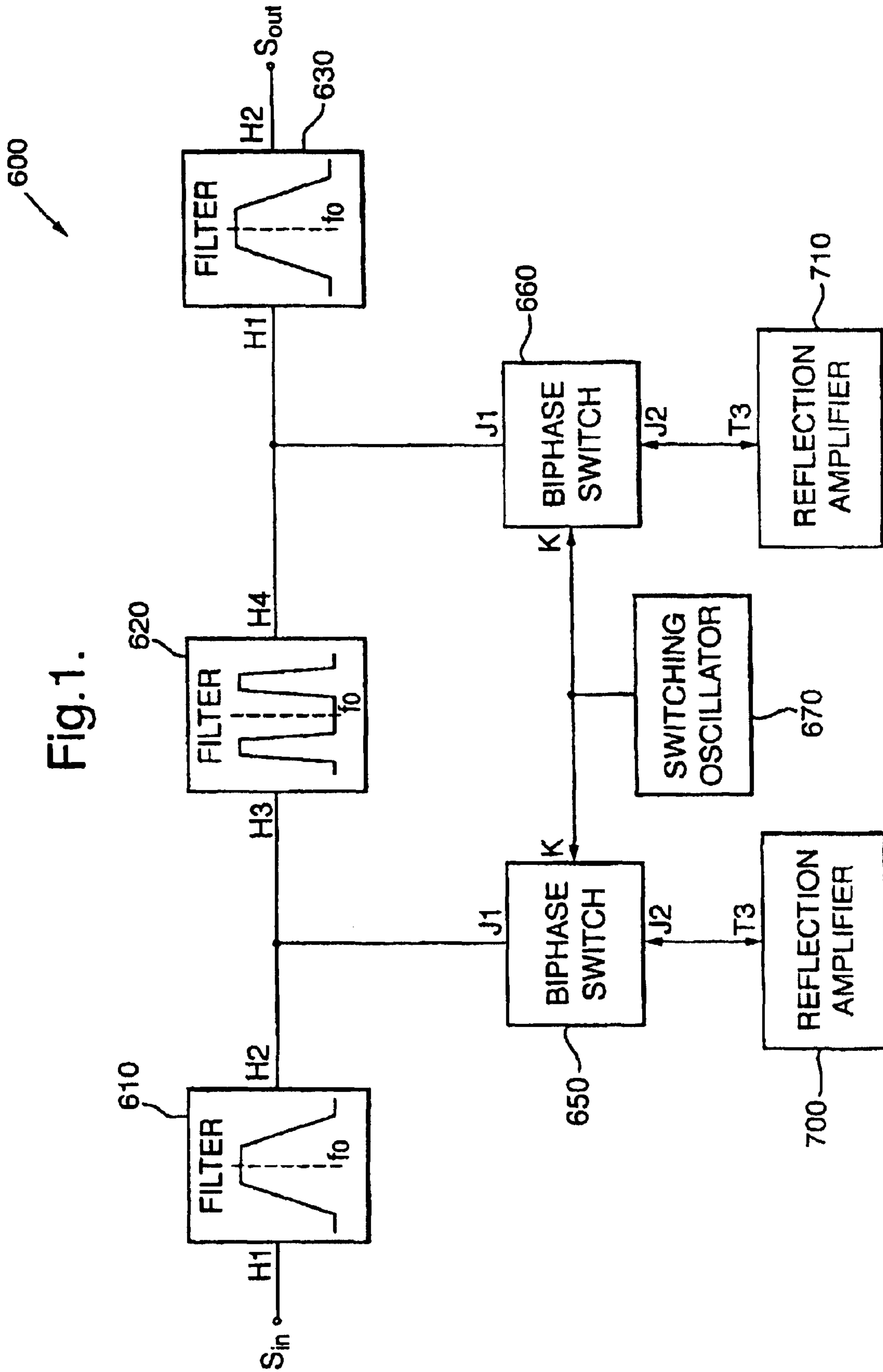
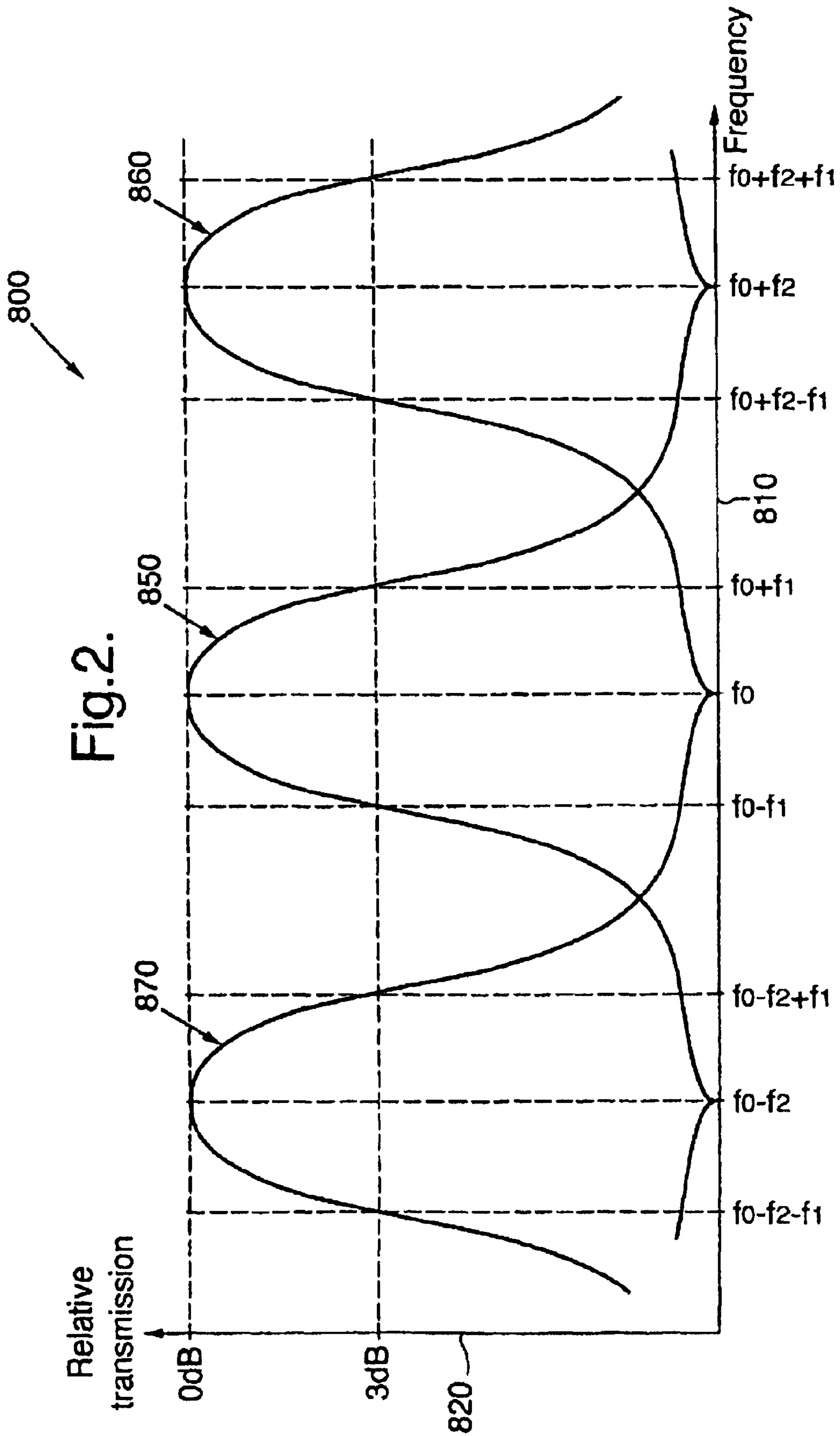
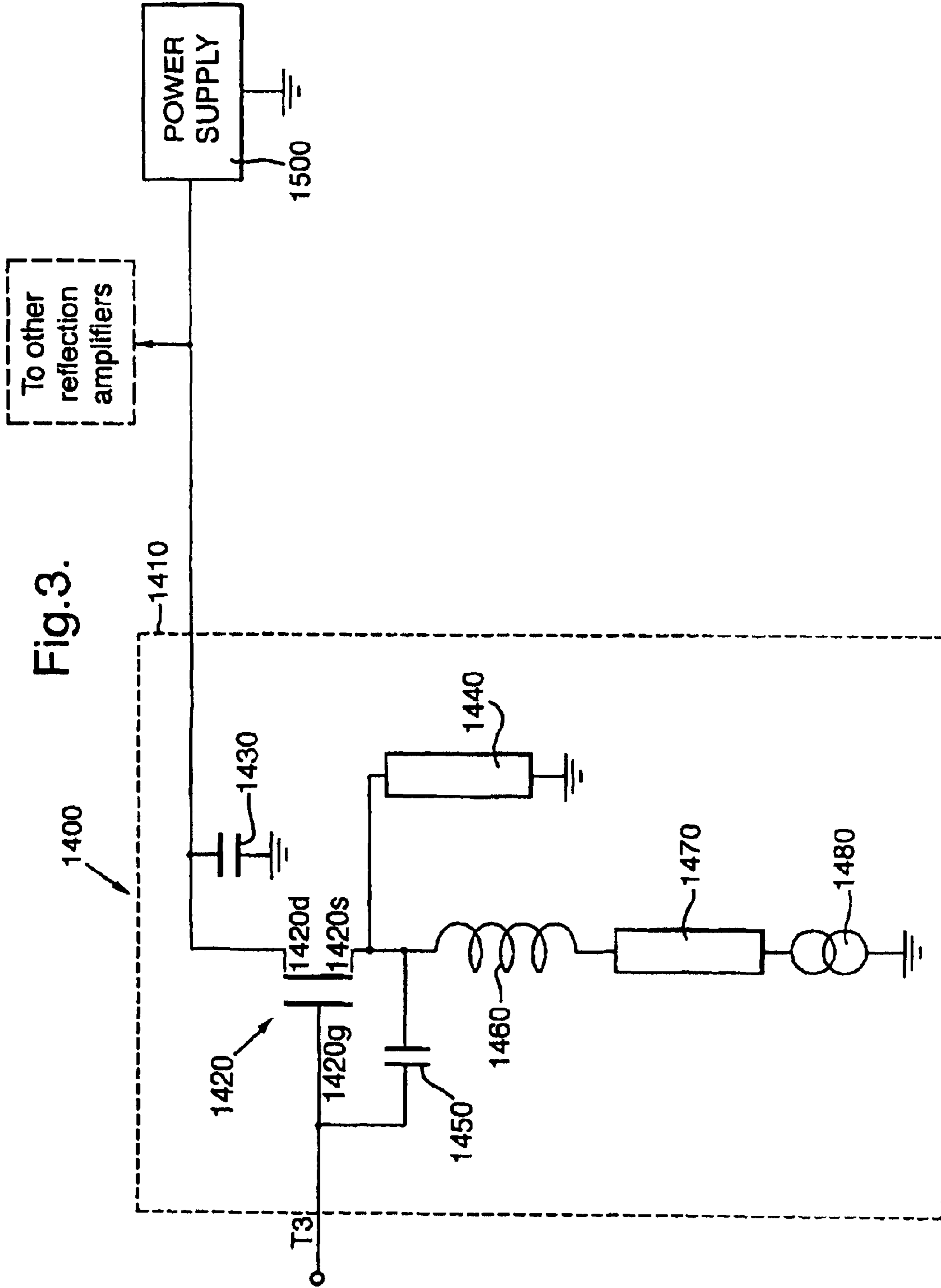

Fig.1.





AMPLIFIER CIRCUIT

Matter enclosed in heavy brackets [] appears in the original patent but forms no part of this reissue specification; matter printed in italics indicates the additions made by reissue.

FIELD OF THE INVENTION

This invention relates to an amplifier circuit, in particular but not exclusively to an amplifier circuit for providing bandpass amplification at intermediate frequencies in radio receivers.

BACKGROUND OF THE INVENTION

Amplifiers are widely used in the prior art for amplifying input signals applied thereto to provide amplified output signals. This is particularly important in radio receivers in which radiation received thereat generates corresponding antenna received signals which typically have an amplitude of microvolts. The radio receivers employ amplifiers therein to amplify such received signals to an amplitude in the order of multivolts to volts, for example to drive a loudspeaker. Since it is difficult to prevent amplifiers designed to amplify at radio frequencies from spontaneously oscillating, especially if they comprise cascaded gain providing stages, it is customary to heterodyne the received signals to lower intermediate frequencies whereat it is easier to provide a high degree of amplification and also provide more selective bandpass signal filtration.

In prior art radio receivers, it is therefore customary to provide a majority of signal amplification required at intermediate frequencies, namely frequencies lying intermediate between that of the radiation received and audio or video frequencies. For example, a radio receiver receives radiation at a frequency of 500 MHz and generates a corresponding antenna received signal also at 500 MHz. The receiver heterodynes the received signal to generate an intermediate frequency signal in a frequency range around 10.7 MHz which is then amplified and filtered, and finally demodulates the amplified intermediate frequency signal to generate a corresponding audio output signal having signal components in a frequency range of 100 Hz to 5 kHz.

Recently, because the radio frequency spectrum is becoming increasingly congested, there is a trend to use an ultra high frequency (UHF) range in contemporary communications systems, namely around 500 MHz; transmission at microwave frequencies, for example 1 GHz to 30 GHz is now also employed. Associated with this is a trend in modern radio receiver design to employ intermediate frequency amplification at several tens of MHz or greater, this is done in order to obtain adequate ghost image rejection associated with using heterodyne processes.

In [modem] *modern* mobile phones, most signal amplification is provided in intermediate frequency amplifier circuits incorporated therein. These circuits comprise transmission amplifiers and associated surface acoustic wave (SAW) or ceramic filters to provide a narrow bandpass signal amplification characteristic; the circuits and their associated filters are conventionally referred to collectively as an "intermediate frequency strip". Such transmission amplifiers consume significant power in operation, for example intermediate frequency amplifier circuits employed in mobile telephones typically consume between several hundred microamperes and several mA of current when operational.

In order to provide modern mobile telephones with extended operating time from their associated batteries, new

types of battery have been researched and developed which provide enhanced charge storage to weight performance, for example rechargeable metal hydride and lithium batteries.

The inventor has appreciated, rather than concentrating on improving battery technology, that reduction in current consumption of intermediate frequency amplifier circuits in radio receivers is desirable to provide extended operating time from batteries. The invention has therefore been made in a endeavour to provide an alternative type of amplifier circuit, for example a circuit especially suitable for use at intermediate frequencies in radio receivers which is capable of requiring less power to operate.

It is known in the art, as described in a Japanese patent application no. JP 55137707, to cascade reflection amplifiers in series and interpose filters therebetween to prevent higher harmonic components generated in preceding stages from propagating to successive stages. The filters are not operable to inhibit signal propagation in a reverse direction along the cascaded series of amplifiers to prevent the occurrence of spontaneous oscillation.

SUMMARY OF THE INVENTION

According to the present invention, there is provided an amplifier circuit for receiving an input signal and providing a corresponding amplified output signal, the circuit characterised in that it comprises:

- (a) a plurality of reflection amplifiers cascaded in series along a signal path and operative to amplify the input signal propagating in a forward direction therealong to provide the output signal; and
- (b) connecting means for connecting the reflection amplifiers to form the signal path and for hindering signal propagation in a reverse direction therealong, thereby counteracting spontaneous oscillation from arising within the circuit, the connecting means incorporating filters which are interposed between neighbouring reflection amplifiers along the signal path, and modulating means for modulating the input signal to associated sideband signal components and converting to and from the sideband components along the path, the filters and the modulating means operative to promote signal propagation in the forward direction along the path and hinder signal propagation in the reverse direction therealong.

This provides the advantage that interposition of the filters between the amplifiers is capable of isolating each amplifier from its neighbouring amplifiers, thereby hindering signal propagation in the reverse direction along the path; incorporation of the modulating means enables the input signal propagating through each amplifier to be converted between a carrier and a sideband signal, thereby enabling it to propagate through the filters in the forward direction along the path.

The circuit provides the benefit that is capable of providing signal amplification and consuming less current during operation compared to prior art amplifier circuits.

One skilled in the art would not expect it to be practicable to connect a plurality of reflection amplifiers together and obtain stable amplification therefrom because of spontaneous interfering oscillations which would arise during operation. The circuit addresses this problem by incorporating the connecting means which promotes intended signal amplification in the circuit and counteracts signal amplification giving rise to spontaneous oscillation therein.

Spontaneous oscillation is defined as self induced oscillation arising along a signal path providing amplification as a consequence of feedback occurring around or within the signal path.

Conveniently, the filters are arranged in series along the signal path, the filters alternating between sideband transmissive filters and sideband rejective filters along the path, and the modulating means is arranged to convert the input signal as it propagates along the signal path alternately between a corresponding carrier signal transmissible substantially through the sideband rejective filters only and a corresponding sideband signal transmissible substantially through the sideband transmissive filters only, thereby promoting input signal propagation in the forward direction along the path and hindering signal propagation in the reverse direction therealong.

In another aspect, the invention provides a method of amplifying an input signal and providing a corresponding amplified output signal, the method characterised in that it includes the steps of:

- (a) providing a plurality of reflection amplifiers cascaded in series along a signal path, and connecting means for connecting the reflection amplifiers to the signal path and operative to promote signal propagation in a forward direction along the path and counteract signal propagation in a reverse direction therealong, the connecting means incorporating filters which are interposed between neighbouring reflection amplifiers along the signal path, and modulating means for modulating the input signal to associated sideband signal components and converting to and from the sideband components along the path, the filters and the modulating means operative to promote signal propagation in the forward direction along the path and hinder signal propagation in the reverse direction therealong;
- (b) receiving the input signal at the signal path;
- (c) directing the input signal through the connecting means to one of the reflection amplifiers for amplification therein to provide an amplified signal;
- (d) directing the amplified signal to another of the reflection amplifiers for further amplification therein;
- (e) repeating step (d) until the amplified signal reaches an output of the signal path; and
- (f) outputting the amplified signal as the output signal from the signal path.

The method provides the advantage that, during amplification, the signal is selectively directed from amplifier to amplifier in a forward direction along the signal path, thereby counteracting any of the amplifiers reamplifying the input signal and hence preventing any feedback loops being established in which spontaneous oscillation can arise.

BRIEF DESCRIPTION OF THE DRAWINGS

An embodiment of the invention will now be described, by way of example only, with reference to the following diagrams in which:

FIG. 1 is a schematic of an amplifier circuit in accordance with an embodiment of the invention;

FIG. 2 is an illustration of signal transmission characteristics of filters for incorporating into the circuit in FIG. 1; and

FIG. 3 is a schematic of a circuit of a reflection amplifier for incorporating into the circuit of FIG. 1.

DETAILED DESCRIPTION OF THE INVENTION

Referring to FIG. 1, there is shown an amplifier circuit according to an embodiment of the invention; the circuit is indicated by 600. It comprises three bandpass filters 610, 620, 630, two biphase switches 650, 660, a switching oscillator 670 and two reflection amplifiers 700, 710. Each of the

amplifiers 700, 710 incorporates a reflection amplifier circuit indicated by 1400 in FIG. 3.

The filters 610, 630 are identical and employ surface acoustic wave (SAW), bulk acoustic wave (BAW) or ceramic filter components. Each of filters 610, 630 provides a band-pass transmission characteristic for signals propagating between its terminals H1, H2. The characteristic comprises a single transmission peak centred at a frequency f_0 having upper and lower -3 dB cut off frequencies of f_0+f_1 and f_0-f_1 respectively. In the circuit 600, f_0 is 100 MHz and f_1 is 50 KHz.

The filter 620 also employs SAW, BAW or ceramic filter components. It provides a double peak transmission characteristic for signals propagating between its terminals H3, H4. The double peak characteristic comprises two transmission peaks, a first peak centred at a frequency f_0+f_2 and a second peak centred at a frequency f_0-f_2 . The first peak has -3 dB upper and lower cut off frequencies of $f_0+f_2+f_1$ and $f_0+f_2-f_1$ respectively. Likewise, the second peak has -3 dB upper and lower cut off frequencies of $f_0-f_2+f_1$ and $f_0-f_2-f_1$ respectively. FIG. 2 provides a graph indicated by 800 illustrating signal transmission characteristics of the filters 610, 620, 630. The graph 800 comprises a first axis 810 representing frequency and a second axis 820 representing relative signal transmission through the filters 610, 620, 630.

In FIG. 2, the single transmission peak of the filters 610, 630 is indicated by 850. Likewise, the first and second transmission peaks of the filter 620 are indicated by 860, 870 respectively. Moreover, the filters 610, 630 also strongly absorb radiation at frequencies around f_0-f_2 and f_0+f_2 , namely around a frequency range of the peaks 860, 870, especially for signals applied to their terminals H2. Furthermore, the filter 620 also strongly absorbs radiation around a frequency range of the peak 850, especially for signals applied to its terminal H4. Referring now to FIG. 1 again, the switching oscillator 670 is operative to generate a binary logic square wave control signal at its output which switches periodically between a logic state 0 and a logic state 1 at the frequency f_2 . The output from the oscillator 670 is connected to input control terminals K of the biphase switches 650, 660.

The biphase switches 650, 660 are identical and each incorporates three terminals, namely signal terminals J1, J2 and an input terminal K as described above. The switch 650 incorporates an inductor and a varactor, also known in the art as a varicap diode; control signals applied to the terminal K of the switch 650 are operative to control a potential applied to the varactor therein, thereby changing its tuning and affecting a phase shift imparted to signals propagating through the switch 650 between its terminals J1, J2. When the control signal from the switching oscillator 670 is in the logic state 0, the switches 650, 660 are operative to provide 0° phase shift; conversely, when the control signal is in the logic state 1, the switches 650, 660 are operative to provide 90° phase shift. Thus, in operation, signals propagating through and subsequently returning from switches 650, 660 via their terminals J1, J2 and amplified by associated reflection amplifiers 700, 710 are periodically switched in phase between 0° and 180° .

Operation of the circuit 600 will now be described with reference to FIGS. 1 and 2. The switching oscillator 670 oscillates at the frequency f_2 and generates the control signal at this frequency at its output. The frequency f_2 is selected to be equal to or greater than twice f_1 . The control signal switches the biphase switches 650, 660 so that they phase modulate signals passing therethrough at the frequency f_2 .

5

The filter **610** receives an input signal S_{in} at its terminal H1 input. The signal S_{in} is for example, generated in a preceding stage (not shown) which heterodynes a received signal to generate the signal S_{in} as an intermediate frequency signal including signal components in a frequency range of $f_0 - f_1$ to $f_0 + f_1$. The signal S_{in} is transmitted through the filter **610** from the terminal H1 to the terminal H2 thereof because its signal components are within the frequency range of the peak **850** of the filter **610**. When the signal S_{in} propagates from the terminal H2, it is unable to pass through the filter **620** because it is not transmissive at frequencies of the signal components; the signal S_{in} thus propagates from the terminal H2 to the terminal J1 of the switch **650** and becomes phase modulated therein to emerge at the terminal J2 as a first modulated signal S_{m1} . The modulated signal S_{m1} propagates to a port T3 of the amplifier **700** which reflectively [amplifiers] amplifies the signal S_{m1} , to provide a second amplified modulated signal [S2] S_{m2} . The signal S_{m2} propagates from the port T3 of the amplifier **700** back through the switch **650** whereat it is further phase modulated to provide a third modulated signal S_{m3} which is output at the terminal J1.

The signal S_{m3} is phase modulated and comprises two sidebands including signal components in the frequency range of peaks **860**, **870**. The sidebands in the signal S_{m3} are prevented from propagating back through the filter **610** because it is non-transmissive at the frequencies of these sidebands. The signal S_{m3} thus propagates from the terminal H3 of the filter **620** to the terminal H4 thereof because the sidebands are within the frequency range of the peaks **860**, **870** of the filter **620**.

The signal S_{m3} propagates from the terminal H4 of the filter **620** to the terminal J1 of the switch **660**. The filter **630** is unable to transmit the signal S_{m3} because it is not transmissive at the frequency ranges of the sidebands of the signal. The signal S_{m3} thus propagates through the switch **660** from its terminal J1 to its terminal J2 to emerge therefrom as a fourth signal S_{m4} . Because the switch **660** provides phase modulation at the frequency f_2 , the sidebands in the signal S_{m3} are heterodyned to generate a signal component in the signal S_{m4} in a frequency range of the peak **850**. The signal S_{m4} propagates from the terminal J2 of the switch **660** to a port T3 of the amplifier **710** wherein it is reflectively amplified to provide an amplified signal S_{m5} . The signal S_{m5} propagates from the port T3 of the amplifier **710** back through the switch **660** whereat it is further phase modulated to emerge as a sixth signal S_{m6} at the terminal J1 of the switch **660**. The signal S_{m6} includes, from the signal S_{m5} , signal components in the frequency range of the peak **850** after amplification thereof.

Because the filter **620** is untransmissive to signals including signal components within the frequency range of the peak **850**, especially at its H4 terminal, the signal S_{m6} is prevented from being transmitted back through the filter **620**. The signal S_{m6} thus propagates through the filter **630** from its terminal H1 to its terminal H2 to propagate therefrom as the signal S_{out} . The signal S_{out} incorporates signal components present in the signal S_{in} which have been amplified by the circuit **600**.

In broad overview, the circuit **600** alternately converts from stage to stage the signal S_{in} to be amplified from carrier frequency, namely within the frequency range of the peak **850**, to sidebands, namely within the frequency range of the peaks **860**, **870**. Thus, the switches **650**, **660** in combination with the filters **610**, **620**, **630** are effective at counteracting signal propagation back in a reverse direction along a path from the output S_{out} to the input S_{in} ; this isolates the amplifiers **700**, **710** thereby enabling greater signal amplification

6

to be achieved in the circuit **600** without spontaneous oscillations arising. Hence, the circuit **600** is capable of providing high signal amplification approaching 50 dB for low current consumption in the order of a few tens of microamperes on account of employing reflection amplifiers.

If the reflection amplifiers **700**, **710** were merely cascaded together without the switches **650**, **660** and the filters **610**, **620**, **630**, severe spontaneous oscillation problems would be encountered which would hinder intended input signal amplification from being achieved.

The circuit **600** can be modified to include more amplification stages, each stage incorporating a reflection amplifier and being isolated from its neighbouring stages by a filter like the filter **610** in a first direction along the signal path, and by a filter like the filter **620** in a second direction along the signal path, said directions being mutually opposite. This enables higher gain to be achieved on account of incorporating more amplifier stages than illustrated in FIG. 1.

The filters **610**, **620**, **630** can be one or more of SAW filters, ceramic filters or tuned inductance/capacitance filters. For high frequency operation, bulk acoustic wave filters can also be employed.

The amplifiers **700**, **710** can be connected to a bias controller arranged to control transistor currents within the amplifiers **700**, **710** thereby enabling dynamic control of their gain, for example where automatic gain control (AGC) is required to cater for a relatively large dynamic range of signals applied at S_{in} .

The amplifier circuit **600** incorporates a cascaded series of reflection amplifiers connected to form a signal path along which input signal amplification occurs. The reflection amplifiers are connected by switched devices, for example the switches **650**, **660** and the filters **610**, **620**, **630**, to facilitate signal propagation in a forward direction along the path for amplification and counteract signal propagation in a reverse direction along the path which can give rise to spontaneous oscillation. This enables higher amplification gains to be achieved for a lower current consumption which is less than required for prior art transmission amplifiers providing comparable gain.

The reflection amplifier circuit **1400** will now be further described with reference to FIG. 3. The circuit **1400** is included within a dotted line **1410** and comprises a silicon or gallium arsenide (GaAs) transistor indicated by **1420**, a capacitor **1430** and a resistor **1440** forming a termination network for the transistor **1420**, a feedback capacitor **1450**, an inductor **1460** and a resistor **1470** forming a bias network, and a current source **1480**. The circuit **1400** includes an input/output port T3 which is connected to a gate electrode **1420g** of the transistor **1420** and to a first terminal of the capacitor **1450**.

The circuit **1400** is connected to a power supply **1500** for supplying the circuit **1400** with power. The supply **1500** is connected to a drain electrode **1420d** of the transistor **1420** and also to a first terminal of the capacitor **1430**; a second terminal of the capacitor **1430** is connected to a signal ground. The capacitor **1450** provides a second terminal which is connected to a source electrode **1420s** of the transistor **1420**, to the resistor **1440** which is grounded, and through the inductor **1460** and the resistor **1470** in series to the source **1480**, which is connected to the signal ground.

In operation of the circuit **1400**, the gate electrode **1420g** receives an incoming signal **6** applied through the port T3. The incoming signal causes a signal current corresponding to the incoming signal to flow between the source electrode **1420g** and the drain electrode **1420d**. The signal current is

coupled through gate-drain and gate-source capacitances of the transistor **1420** and also through the capacitor **1450**, thereby generating an outgoing signal at the gate electrode **1420g** which is an amplified version of the incoming signal. The incoming signal is reflected at the gate electrode **1420g** where it is combined with the outgoing signal which propagates out through the port **T3**.

On account of the circuit **1400** receiving the incoming signal and returning the combined signal via one terminal, namely the port **T3**, it behaves as a reflecting negative resistance. The circuit **1400** and its associated components shown within the dotted line **1410** are capable of providing a high power gain approaching +30 dB for a drain/source current through the transistor **1420** in the order of a few tens of microamperes. Such a high power gain is not achievable from a transmission amplifier operating on such a low supply current.

When incorporated into a mobile telephone as part of its intermediate frequency strip, the amplifier circuit **600** incorporating a plurality of the circuits **1400** is capable of providing an order of magnitude reduction in telephone current consumption associated with amplifying signals therein at intermediate frequencies compared to prior art. This is of considerable benefit which provides extended duration of telephone operation from power supplied from rechargeable batteries for example.

It will be appreciated by those skilled in the art that variations can be made to the circuit **600** without departing from the scope of the invention. Thus, alternative switching devices, or equivalent devices, can be used with reflection amplifiers provided they exhibit similar characteristics to the switches and filters in the circuit **600**, namely for counteracting spurious oscillation from arising.

The circuit **600** can be incorporated into radio receivers, for example mobile telephones, to function as intermediate frequency strips therein. Moreover, when provided with a demodulator to convert signals output from the circuit **600**, the circuit is capable of operating as an IF receiver.

What is claimed is:

1. An amplifier circuit for receiving an input signal and providing a corresponding amplified output signal, the circuit comprising:

- a) a plurality of reflection amplifiers cascaded in series along a signal path and operative to amplify the input signal propagating in a forward direction therealong to provide the output signal; and
- b) connecting means for connecting the reflection amplifiers to form the signal path and for hindering signal propagation in a reverse direction therealong, thereby counteracting spontaneous oscillation from arising within the circuit, the connecting means incorporating filters which are interposed between neighboring reflection amplifiers along the signal path, and modulating means for modulating the input signal to associated sideband signal components and converting to and from the associated sideband signal components along the path, the filters and the modulating means being operative to promote signal propagation in the forward direction along the path and hinder signal propagation in the reverse direction therealong.

2. The circuit according to claim **1**, wherein the filters are arranged in series along the signal path, the filters alternating between sideband transmissive filters and sideband rejective filters along the path, and the modulating means is arranged to convert the input signal as it propagates along the signal path alternately between a corresponding carrier signal transmissible substantially through the sideband rejective filters only and a corresponding sideband signal transmis-

sible substantially through the sideband transmissive filters only, thereby promoting input signal propagation in the forward direction along the path and hindering signal propagation in the reverse direction therealong.

3. The circuit according to claim **1**, wherein the modulating means comprises a plurality of phase switches, each phase switch having a respective reflection amplifier associated therewith.

4. The circuit according to claim **3**, wherein the phase switches are interposed between the filters and their associated amplifiers.

5. The circuit according to claim **1**, wherein the modulating means is operable at a rate having an associated frequency which is half a frequency separation of transmission peaks of the sideband transmission characteristics of the [sideband] *sideband* transmissive filters.

6. The circuit according to claim **3**, wherein the phase switches each incorporate a tuned circuit comprising an inductor and a modulated varactor.

7. An intermediate frequency strip incorporating an amplifier circuit for receiving an input signal and providing a corresponding amplified output signal, the circuit comprising:

- a) a plurality of reflection amplifiers cascaded in series along a signal path and operative to amplify the input signal propagating in a forward direction therealong to provide the output signal; and
- b) connecting means for connecting the reflection amplifiers to form the signal path and for hindering signal propagation in a reverse direction therealong, thereby counteracting spontaneous oscillation from arising within the circuit, the connecting means incorporating filters which are interposed between neighboring reflection amplifiers along the signal path, and modulating means for modulating the input signal to associated sideband signal components and converting to and from the associated sideband signal components along the path, the filters and the modulating means being operative to promote signal propagation in the forward direction along the path and hinder signal propagation in the reverse direction therealong.

8. An intermediate frequency receiver incorporating an amplifier circuit for receiving an input signal and providing a corresponding amplified output signal, the circuit comprising:

- a) a plurality of reflection amplifiers cascaded in series along a signal path and operative to amplify the input signal propagating in a forward direction therealong to provide the output signal; and
- b) connecting means for connecting the reflection amplifiers to form the signal path and for hindering signal propagation in a reverse direction therealong, thereby counteracting spontaneous oscillation from arising within the circuit, the connecting means incorporating filters which are interposed between neighboring reflection amplifiers along the signal path, and modulating means for modulating the input signal to associated sideband signal components and converting to and from the associated sideband signal components along the path, the filters and the modulating means being operative to promote signal propagation in the forward direction along the path and hinder signal propagation in the reverse direction therealong.

9. A mobile telephone incorporating an amplifier circuit for receiving an input signal and providing a corresponding amplified output signal, the circuit comprising:

- a) a plurality of reflection amplifiers cascaded in series along a signal path and operative to amplify the input

signal propagating in a forward direction therealong to provide the output signal; and

- b) connecting means for connecting the reflection amplifiers to form the signal path and for hindering signal propagation in a reverse direction therealong, thereby counteracting spontaneous oscillation from arising within the circuit, the connecting means incorporating filters which are interposed between neighboring reflection amplifiers along the signal path, and modulating means for modulating the input signal to associated sideband signal components and converting to and from the associated sideband signal components along the path, the filters and the modulating means being operative to promote signal propagation in the forward direction along the path and hinder signal propagation in the reverse direction therealong.

10. A method of amplifying an input signal and providing a corresponding amplified output signal, the method comprising the steps of:

- a) providing a plurality of reflection amplifiers cascaded in series along a signal path, and connecting means for connecting the reflection amplifiers to the signal path and operative to promote signal propagation in a forward direction along the path and counteract signal propagation in a reverse direction therealong, the connecting means incorporating filters which are interposed between neighboring reflection amplifiers along the signal path, and modulating means for modulating the input signal to associated sideband signal components and converting to and from associated sideband signal components along the path, the filters and the modulating means being operative to promote signal propagation in the forward direction along the path and hinder signal propagation in the reverse direction therealong;
- b) receiving the input signal at the signal path;
- c) directing the input signal through the connecting means to one of the reflection amplifiers for amplification therein to provide an amplified signal;
- d) directing the amplified signal in the forward direction to another of the reflection amplifiers for further amplification therein;
- e) repeating step (d) until the amplified signal reaches an output of the signal path; and
- f) outputting the amplified signal as the output signal from the signal path.

11. An amplifier circuit for receiving an input signal and providing a corresponding amplified output signal, the circuit comprising:

- a) a plurality of reflection amplifiers cascaded in series along a signal path and operative to amplify the input signal propagating in a forward direction therealong to provide the output signal; and
- b) connecting means for connecting the reflection amplifiers to form the signal path and for hindering signal propagation in a reverse direction therealong, thereby counteracting spontaneous oscillation from arising within the circuit, the connecting means incorporating one or more filters which are interposed between neighboring reflection amplifiers along the signal path, and modulating means for modulating the input signal to associated sideband signal components and converting to and from the associated sideband signal components along the path, the one or more filters and the modulating means being operative to promote signal propagation in the forward direction along the path and hinder signal propagation in the reverse direction therealong.

12. The circuit according to claim 11, wherein the one or more filters are arranged in series along the signal path, the one or more filters alternating between sideband transmissive filters and sideband rejective filters along the path, and the modulating means is arranged to convert the input signal as it propagates along the signal path alternately between a corresponding carrier signal transmission substantially through the sideband rejective filters only and a corresponding sideband signal transmissible substantially through the sideband transmissive filters only, thereby promoting input signal propagation in the forward direction along the path and hindering signal propagation in the reverse direction therealong.

13. The circuit according to claim 11, wherein the modulating means comprises a plurality of phase switches, each phase switch having a respective reflection amplifier associated therewith.

14. The circuit according to claim 13, wherein the phase switches are interposed between the one or more filters and their associated amplifiers.

15. The circuit according to claim 13, wherein the phase switches each incorporate a tuned circuit comprising an inductor and a modulated varactor.

16. The circuit according to claim 11, wherein the modulating means is operable at a rate having an associated frequency which is half a frequency separation of transmission peaks of the sideband transmission characteristics of the sideband transmissive filters.

17. The circuit according to claim 11 further comprising a first filter preceding the first reflection amplifier in the series along the signal path.

18. The circuit according to claim 17 further comprising a last filter succeeding the last reflection amplifier in the series along the signal path.

19. The circuit according to claim 18, wherein the first filter, the one or more filters which are interposed between neighboring reflection amplifiers along the signal path, and the last filter are arranged in series along the signal path, all of said filters alternating between sideband transmissive filters and sideband rejective filters along the path, and the modulating means is arranged to convert the input signal as it propagates along the signal path alternately between a corresponding carrier signal transmissible substantially through the sideband rejective filters only and a corresponding sideband signal transmissible substantially through the sideband transmissive filters only, thereby promoting input signal propagation in the forward direction along the path and hindering signal propagation in the reverse direction therealong.

20. The circuit according to claim 19, wherein the modulating means comprises a plurality of phase switches, each phase switch having a respective amplifier associated therewith.

21. The circuit according to claim 20, wherein the phase switches are interposed between the first filter, the one or more filters which are interposed between neighboring reflection amplifiers along the signal path, and the last filter and their associated amplifiers.

22. The circuit according to claim 19, wherein the first filter, the one or more filters which are interposed between neighboring reflection amplifiers along the signal path, and the last filter are selected from the group consisting of SAW filters, ceramic filters, tuned inductance/capacitance filters, and bulk acoustic wave filters.

23. The circuit according to claim 11, wherein the plurality of reflection amplifiers are connected to a bias controller arranged to control transistor currents within the amplifiers.

24. The circuit according to claim 19, wherein the phase switches each incorporate a tuned circuit comprising an inductor and a modulated varactor.

25. An intermediate frequency strip incorporating an amplifier circuit for receiving an input signal and providing a corresponding amplified output signal, the circuit comprising:

a) a plurality of reflection amplifiers cascaded in series along a signal path and operative to amplify the input signal propagating in a forward direction therealong to provide the output signal; and

b) connecting means for connecting the reflection amplifiers to form the signal path and for hindering signal propagation in a reverse direction therealong, thereby counteracting spontaneous oscillation from arising within the circuit, the connecting means incorporating one or more filters which are interposed between neighboring reflection amplifiers along the signal path, and modulating means for modulating the input signal to associated sideband signal components and converting to and from the associated sideband signal components along the path, the one or more filters and the modulating means being operative to promote signal propagation in the forward direction along the path and hinder signal propagation in the reverse direction therealong.

26. The circuit according to claim 25, the one or more filters are arranged in series along the signal path, the one or more filters alternating between sideband transmissive filters and sideband rejective filters along the path, and the modulating means is arranged to convert the input signal as it propagates along the signal path alternately between a corresponding carrier signal transmissible substantially through the sideband rejective filters only and a corresponding sideband signal transmissible substantially through the sideband transmissive filters only, thereby promoting input signal propagation in the forward direction along the path and hindering signal propagation in the reverse direction therealong.

27. The circuit according to claim 25, wherein the modulating means comprises a plurality of phase switches, each phase switch having a respective amplifier associated therewith.

28. The circuit according to claim 27 wherein the phase switches are interposed between the one or more filters and their associated amplifiers.

29. The circuit according to claim 25, wherein the modulating means is operable at a rate having an associated frequency which is half a frequency separation of transmission peaks of the sideband transmission characteristics of the sideband transmissive filters.

30. The circuit according to claim 25 further comprising a first filter preceding the first reflection amplifier in the series along the signal path.

31. The circuit according to claim 30 further comprising a last filter succeeding the last reflection amplifier in the series along the signal path.

32. The circuit according to claim 31, wherein the first filter, the one or more filters which are interposed between neighboring reflection amplifiers along the signal path, and the last filter are arranged in series along the signal path, all of said filters alternating between sideband transmissive filters and sideband rejective filters along the path, and the modulating means is arranged to convert the input signal as it propagates along the signal path alternately between a corresponding carrier signal transmissible substantially through the sideband rejective filters only and a corresponding sideband signal transmissible substantially through the

sideband transmissive filters only, thereby promoting input signal propagation in the forward direction along the path and hindering signal propagation in the reverse direction therealong.

33. The circuit according to claim 32, wherein the modulating means comprises a plurality of phase switches, each phase switch having a respective amplifier associated therewith.

34. The circuit according to claim 33 wherein the phase switches are interposed between the first filter, the one or more filters which are interposed between neighboring reflection amplifiers along the signal path, and the last filter and their associated amplifiers.

35. The circuit according to claim 32, wherein the first filter, the one or more filters which are interposed between neighboring reflection amplifiers along the signal path, and the last filter are selected from the group consisting of SAW filters, ceramic filters, tuned inductance/capacitance filters, and bulk acoustic wave filters.

36. The circuit according to claim 25, wherein the plurality of reflection amplifiers are connected to a bias controller arranged to control transistor currents within the amplifiers.

37. An intermediate frequency receiver incorporating an amplifier circuit for receiving an input signal and providing a corresponding amplified output signal, the circuit comprising:

a) a plurality of reflection amplifiers cascaded in series along a signal path and operative to amplify the input signal propagating in a forward direction therealong to provide the output signal; and

b) connecting means for connecting the reflection amplifiers to form the signal path and for hindering signal propagation in a reverse direction therealong, thereby counteracting spontaneous oscillation from arising within the circuit, the connecting means incorporating one or more filters which are interposed between neighboring reflection amplifiers along the signal path, and modulating means for modulating the input signal to associated sideband signal components and converting to and from the associated sideband signal components along the path, the one or more filters and the modulating means being operative to promote signal propagation in the forward direction along the path and hinder signal propagation in the reverse direction therealong.

38. The circuit according to claim 37, the one or more filters are arranged in series along the signal path, the one or more filters alternating between sideband transmissive filters and sideband rejective filters along the path, and the modulating means is arranged to convert the input signal as it propagates along the signal path alternately between a corresponding carrier signal transmissible substantially through the sideband rejective filters only and a corresponding sideband signal transmissible substantially through the sideband transmissive filters only, thereby promoting input signal propagation in the forward direction along the path and hindering signal propagation in the reverse direction therealong.

39. The circuit according to claim 37, wherein the modulating means comprises a plurality of phase switches, each phase switch having a respective amplifier associated therewith.

40. The circuit according to claim 39, wherein the phase switches are interposed between the one or more filters and their associated amplifiers.

41. The circuit according to claim 39, wherein the phase switches each incorporate a tuned circuit comprising an inductor and a modulated varactor.

42. The circuit according to claim 37, wherein the modulating means is operable at a rate having an associated frequency which is half a frequency separation of transmission peaks of the sideband transmission characteristics of the sideband transmissive filters.

43. The circuit according to claim 37 further comprising a first filter preceding the first reflection amplifier in the series along the signal path.

44. The circuit according to claim 43 further comprising a last filter succeeding the last reflection amplifier in the series along the signal path.

45. The circuit according to claim 44, wherein the first filter, the one or more filters which are interposed between neighboring reflection amplifiers along the signal path, and the last filter are arranged in series along the signal path, all of said filters alternating between sideband transmissive filters and sideband rejective filters along the path, and the modulating means is arranged to convert the input signal as it propagates along the signal path alternately between a corresponding carrier signal transmissible substantially through the sideband rejective filters only and a corresponding sideband signal transmissible substantially through the sideband transmissive filters only, thereby promoting input signal propagation in the forward direction along the path and hindering signal propagation in the reverse direction therealong.

46. The circuit according to claim 45, wherein the modulating means comprises a plurality of phase switches, each phase switch having a respective amplifier associated therewith.

47. The circuit according to claim 46, wherein the phase switches are interposed between the first filter, the one or more filters which are interposed between neighboring reflection amplifiers along the signal path, and the last filter and their associated amplifiers.

48. The circuit according to claim 45, wherein the first filter, the one or more filters which are interposed between neighboring reflection amplifiers along the signal path, and the last filter are selected from the group consisting of SAW filters, ceramic filters, tuned inductance/capacitance filters, and bulk acoustic wave filters.

49. The circuit according to claim 37, wherein the plurality of reflection amplifiers are connected to a bias controller arranged to control transistor currents within the amplifiers.

50. A mobile telephone incorporating an amplifier circuit for receiving an input signal and providing a corresponding amplified output signal, the circuit comprising:

a) a plurality of reflection amplifiers cascaded in series along a signal path and operative to amplify the input signal propagating in a forward direction therealong to provide the output signal; and

b) connecting means for connecting the reflection amplifiers to form the signal path and for hindering signal propagation in a reverse direction therealong, thereby counteracting spontaneous oscillation from arising within the circuit, the connecting means incorporating one or more filters which are interposed between neighboring reflection amplifiers along the signal path, and modulating means for modulating the input signal to associated sideband signal components and converting to and from the associated sideband signal components along the path, the one or more filters and the modulating means being operative to promote signal propagation in the forward direction along the path and hinder signal propagation in the reverse direction therealong.

51. The circuit according to claim 50, the one or more filters are arranged in series along the signal path, the one

or more filters alternating between sideband transmissive filters and sideband rejective filters along the path, and the modulating means is arranged to convert the input signal as it propagates along the signal path alternately between a corresponding carrier signal transmissible substantially through the sideband rejective filters only and a corresponding sideband signal transmissible substantially through the sideband transmissive filters only, thereby promoting input signal propagation in the forward direction along the path and hindering signal propagation in the reverse direction therealong.

52. The circuit according to claim 50, wherein the modulating means comprises a plurality of phase switches, each phase switch having a respective amplifier associated therewith.

53. The circuit according to claim 52, wherein the phase switches are interposed between the one or more filters and their associated amplifiers.

54. The circuit according to claim 52, wherein the phase switches each incorporate a tuned circuit comprising an inductor and a modulated varactor.

55. The circuit according to claim 50, wherein the modulating means is operable at a rate having an associated frequency which is half a frequency separation of transmission peaks of the sideband transmission characteristics of the sideband transmissive filters.

56. The circuit according to claim 50 further comprising a first filter preceding the first reflection amplifier in the series along the signal path.

57. The circuit according to claim 56 further comprising a last filter succeeding the last reflection amplifier in the series along the signal path.

58. The circuit according to claim 57, wherein the first filter, the one or more filters which are interposed between neighboring reflection amplifiers along the signal path, and the last filter are arranged in series along the signal path, all of said filters alternating between sideband transmissive filters and sideband rejective filters along the path, and the modulating means is arranged to convert the input signal as it propagates along the signal path alternately between a corresponding carrier signal transmissible substantially through the sideband rejective filters only and a corresponding sideband signal transmissible substantially through the sideband transmissive filters only, thereby promoting input signal propagation in the forward direction along the path and hindering signal propagation in the reverse direction therealong.

59. The circuit according to claim 58, wherein the modulating means comprises a plurality of phase switches, each phase switch having a respective amplifier associated therewith.

60. The circuit according to claim 59, wherein the phase switches are interposed between the first filter, the one or more filters which are interposed between neighboring reflection amplifiers along the signal path, and the last filter and their associated amplifiers.

61. The circuit according to claim 57, wherein the first filter, the one or more filters which are interposed between neighboring reflection amplifiers along the signal path, and the last filter are selected from the group consisting of SAW filters, ceramic filters, tuned inductance/capacitance filters, and bulk acoustic wave filters.

62. The circuit according to claim 50, wherein the plurality of reflection amplifiers are connected to a bias controller arranged to control transistor currents within the amplifiers.

15

63. A method of amplifying an input signal and providing a corresponding amplified output signal, the method comprising the steps of:

- a) a plurality of reflection amplifiers cascaded in series along a signal path and operative to amplify the input signal propagating in a forward direction therealong to provide the output signal; and
 - b) connecting means for connecting the reflection amplifiers to form the signal path and for hindering signal propagation in a reverse direction therealong, thereby counteracting spontaneous oscillation from arising within the circuit, the connecting means incorporating one or more filters which are interposed between neighboring reflection amplifiers along the signal path, and modulating means for modulating the input signal to associated sideband signal components and converting to and from the associated sideband signal components along the path, the one or more filters and the modulating means being operative to promote signal propagation in the forward direction along the path and hinder signal propagation in the reverse direction therealong.
64. The method according to claim 63 further comprising providing a first filter preceding the first reflection amplifier in the series along the signal path.

16

65. The method according to claim 64 further comprising providing a last filter succeeding the last reflection amplifier in the series along the signal path.

66. The method according to claim 65, wherein the modulating means comprises a plurality of phase switches, each phase switch having a respective reflection amplifier associated therewith.

67. The method according to claim 66, wherein directing the input signal through the connecting means to one of the reflection amplifiers comprises directing the input signal through the first filter and through a first of the plurality of phase switches.

68. The method according to claim 67, wherein directing the amplified signal in the forward direction to another of the reflection amplifiers comprises directing the amplified signal back through the first of the plurality of phase switches, through one of the one or more filters, and through a second of the plurality of phase switches.

* * * * *