

US00RE40841E

(19) **United States**
(12) **Reissued Patent**
Fleszewski, III et al.

(10) **Patent Number:** **US RE40,841 E**
(45) **Date of Reissued Patent:** **Jul. 14, 2009**

(54) **SOUND RECORDING AND REPRODUCTION SYSTEM FOR MODEL TRAIN USING INTEGRATED DIGITAL COMMAND CONTROL**

(75) Inventors: **Vincent S. Fleszewski, III**, Crown Point, IN (US); **Kelly Poles**, Rochester, MN (US); **Michael J. Novosel**, Chicago, IL (US)

(73) Assignee: **Real Rail Effects, Inc.**, Chicago, IL (US)

(21) Appl. No.: **10/911,470**

(22) Filed: **Aug. 3, 2004**

Related U.S. Patent Documents

Reissue of:

(64) Patent No.: **5,855,004**
Issued: **Dec. 29, 1998**
Appl. No.: **08/851,200**
Filed: **May 5, 1997**

U.S. Applications:

(60) Division of application No. 09/592,461, filed on Jun. 9, 2000, now Pat. No. Re. 38,660, which is a continuation-in-part of application No. 08/289,257, filed on Aug. 11, 1994, now abandoned.

(51) **Int. Cl.**
A63H 19/14 (2006.01)

(52) **U.S. Cl.** **105/1.5; 704/201; 704/272**

(58) **Field of Classification Search** **704/201, 704/272; 318/51; 446/410, 175; 105/1.5**
See application file for complete search history.

(56) **References Cited**

U.S. PATENT DOCUMENTS

3,839,822 A * 10/1974 Rexford 446/410
3,893,107 A * 7/1975 Schedler 340/384.3
4,266,368 A * 5/1981 Nyman 446/410
4,267,551 A * 5/1981 Dankman et al. 340/384.3

4,293,851 A * 10/1981 Beyl, Jr. 340/384.72
4,314,236 A * 2/1982 Mayer et al. 340/384.71
4,325,199 A * 4/1982 McEdwards 446/130
4,335,381 A * 6/1982 Palmer 340/825.21
4,341,982 A * 7/1982 Lahti et al. 318/51
4,524,932 A * 6/1985 Bodziak 246/247
4,572,995 A * 2/1986 Enami 388/812
4,572,996 A * 2/1986 Hanschke et al. 388/809
4,613,103 A * 9/1986 Waranowitz 246/473 A

(Continued)

OTHER PUBLICATIONS

J.J.P., "Hear the Telegrapher," Model Railroader, pp. 37, Aug. 1953.

(Continued)

Primary Examiner—Susan McFadden

(74) *Attorney, Agent, or Firm*—Patents & TMS, P.C.

(57) **ABSTRACT**

A system is provided for recording, storing and reproducing sound for playing back in an environment requiring simulated sounds, voices, and/or sound effects. Sounds are recorded on a chip and played back in an asynchronous manner from the chip as a result of activation of a switch or inertial movement within the system. A Hall-effect sensor, reed switch or momentary switch or the like may be implemented for enabling activation of the recorded sound from the chip for broadcasting. A compander compresses the sound on the chip and expands the compressed sound for playback. Employing the above system for audio storage, a sound, motor and special effects controller may be created for model train applications as well. The different functions of the sound unit are controlled through a discrete bi-polar digital command control signal using a unique address for each unit. A synchronous means of play back may also be employed when the system is used with the bi-polar signal using a sensor. In addition to the analog sound storage, the same concepts and ideas may be applied to a digital sound recording and play back device as well.

37 Claims, 20 Drawing Sheets

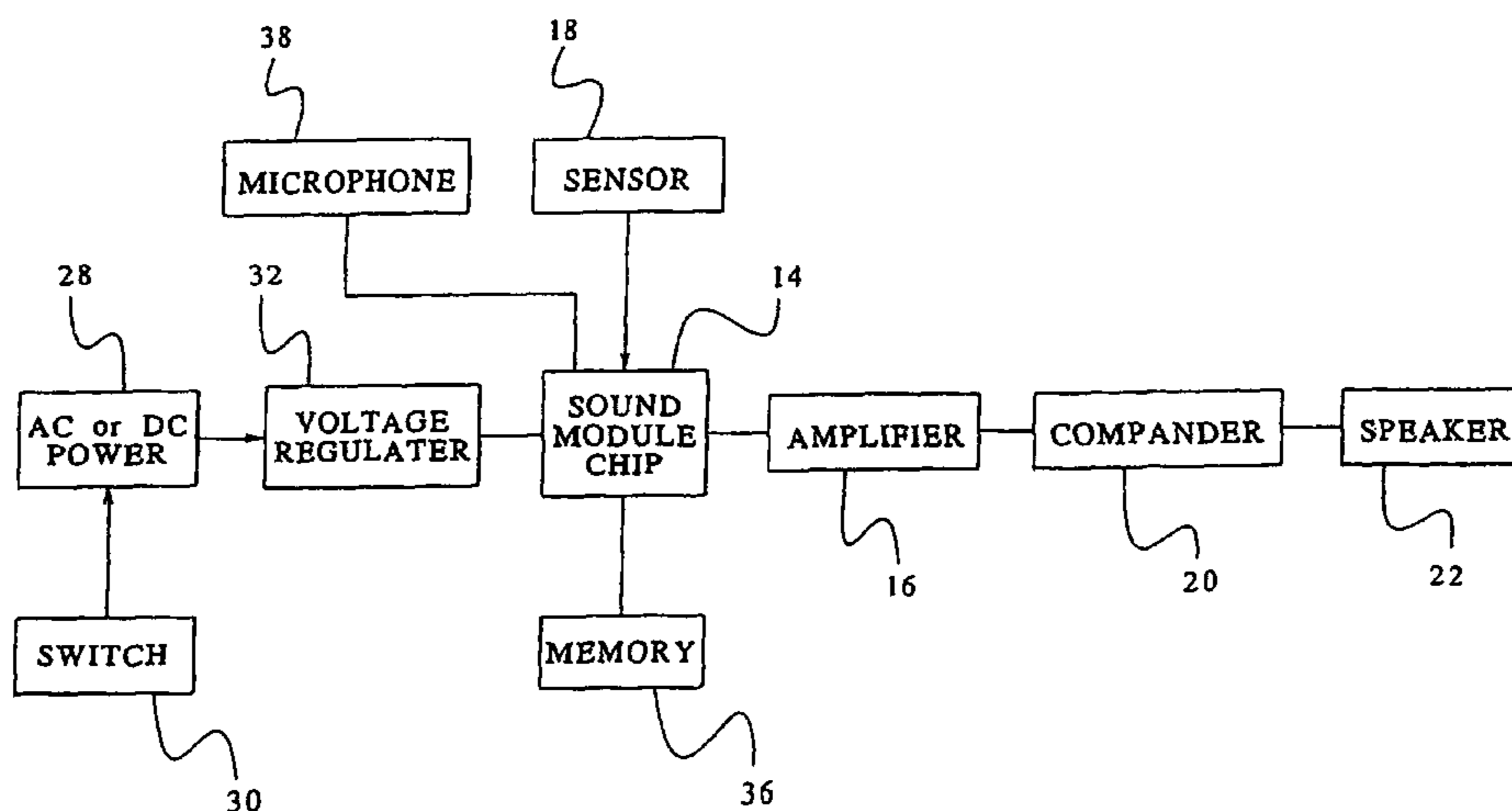

U.S. PATENT DOCUMENTS

| | | | | |
|-------------|-----|---------|----------------------|------------|
| 4,914,431 | A * | 4/1990 | Severson et al. | 340/825.69 |
| 4,946,416 | A * | 8/1990 | Stern et al. | 446/409 |
| 5,174,216 | A * | 12/1992 | Miller et al. | 104/296 |
| 5,251,856 | A * | 10/1993 | Young et al. | 246/4 |
| 5,267,318 | A * | 11/1993 | Severson et al. | 704/270 |
| 5,341,453 | A * | 8/1994 | Hill | 388/815 |
| B 5,045,016 | * | 8/1995 | Stern et al. | 446/409 |
| 5,441,223 | A * | 8/1995 | Young et al. | 246/4 |
| 5,448,142 | A * | 9/1995 | Severson et al. | 318/280 |
| 5,773,939 | A * | 6/1998 | Severson et al. | 318/51 |

OTHER PUBLICATIONS

“Railroad Sounds,” *Railroad Model Craftsman*, pp. 22–23, Sep. 1958.

Chaudiere, “Authentic Sound in Locomotives,” *Model Railroader*, pp. 33–34, May 1959.

Melle, “What is the Sound/Light Unit,” *Railroad Model Craftsman*, pp. 30–33, Mar. 1962.

Baker, “Diesel Horn Works on a Dry Cell,” *Model Railroader*, pp. 38–40, Apr. 1964.

Sherry, “Railroad Sound Recordings,” *Railroad Model Craftsman*, pp. 26–27, Mar. 1966.

Chaudiere, “Whistle, Bell, Steam, and Exhaust Sounds,” *Model Railroader*, pp. 44–49, May 1966.

Vogt, “The Monster Diesel Horn,” *Model Railroader*, pp. 50–51, Dec. 1966.

Sohl, “Simple Soundmaker for Model Railroaders,” *Model Railroader*, pp. 56, 58, Apr. 1967.

Grande, “Magic Diesel Horn,” *Model Railroader*, pp. 56–58, Apr. 1969.

Armstrong, “Realistic Sound And Scale, Part 1,” *Model Railroader*, pp. 59–62, Jul. 1969.

Armstrong, “Realistic Sounds And Scale, Part 2,” *Model Railroader*, pp. 61, Aug. 1969.

Editorial Staff, Trade Topics New Products Built and Tested by MR’s Staff Steam Locomotive Sound System, *Model Railroader*, pp. 12–13, Jan. 1970.

Cook, “Tender Speaker for Noise Effects,” *Model Railroader*, pp. 62b–63, Jan. 1971.

Product Review, *Finelines*, pp. 4, May 1971.

Fiehmann, “Sounds for Geared Locomotives,” *Railroad Model Craftsman*, pp. 33–35, Jan. 1972.

Larson, “The Ditrack 1600,” *Model Railroader*, pp. 37–40, Aug. 1972.

Brewster, “A Spriced-Up Heisler,” *Model Railroader*, pp. 66–73, Feb. 1973.

Stevens, “Symposium on Electronics: Diesel Engine Sound–Effect Generator,” *Model Railroader*, pp. 88, Oct. 1973.

Langley et al., “Top Performance and Sound From a Shay,” *Model Railroader*, pp. 46–49, Nov. 1973.

Chaudiere, “Echoes Add to Sound Effects,” *Model Railroader*, pp. 42–43, Dec. 1973.

Glaab, “Add a Tape Recorder Input to your PFM Sound System,” *Railroad Model Craftsman*, pp. 58–59, Apr. 1976.

Fiehmann, “The Case for Radio Control,” *Railroad Model Craftsman*, pp. 30–33, May 1976.

Hediger, “Ho Diesel Sound System,” *Model Railroader*, pp. 35–36, May 1977.

Thorne, “Action Crossing: Lights Flash, A Diesel Horn Blows, and a Bells Ring,” *Model Railroader*, pp. 79–82, Jul. 1977.

Lambert Associates, “Ho Sound System,” *Model Railroader*, pp. 33–34, Aug. 1977.

Miller, “Simplified Steam Exhaust System,” *Railroad Model Craftsman*, pp. 74–75, Oct. 1977.

North, “Upgrading Your Sound System, Part 1,” *Gazette*, pp. 48–50, Jan./Feb. 1978.

North, “Upgrading Your Sound System, Part 2,” *Gazette*, pp. 47–49, May/Jun. 1978.

Eudaly, “Supersonic–Frequency A.C. to Power Lights and Sound Systems,” *Railroad Model Craftsman*, pp. 44–46, Aug. 1978.

North, “Upgrading Your Sound System, Part 3,” *Gazette*, pp. 27–33, Nov./Dec. 1978.

“All–Scale Diesel Horn,” *Model Railroader*, pp. 65, Dec. 1978.

Rakiecz, Jr., “A Sound Ideal,” *Model Railroader*, pp. 102–104, 106, Apr. 1979.

Dressler, “Whistle Handle for the Fyfee Electronics Steam Sound Generator,” pp. 110–111, Jun. 1979.

North, “An Auxillary ‘Sound’ Car,” *Gazette*, pp. 32–33, Sep./Oct. 1979.

Sperandeo, “Commercial Command Control Systems,” *Model Railroader*, pp. 80–81, Nov. 1979.

Cassler, “Action for Diesels,” *Railroad Model Craftsman*, pp. 64–68, Nov. 1979.

Findley, “Improved Sound–System Keying,” *Railroad Model Craftsman*, pp. 104–105, Nov. 1979.

Gutierrez, “Introducing the CTC–16: A 16–Channel Command Control System You Can Build, Part 1,” *Model Railroader*, pp. 64–67, Dec. 1979.

Gutierrez, “Introducing the CTC–16: A Command Control System You Can Build, Part 2,” *Model Railroader*, pp. 86–93, Jan. 1980.

Gutierrez, “Introducing the CTC–16: A Command Control System You Can Build, Part 3,” *Model Railroader*, pp. 89–92, Feb. 1980.

Gutierrez, “Introducing the CTC–16: A Command Control System You Can Build, Part 4,” *Model Railroader*, pp. 89–93, Mar. 1980.

Gutierrez, “Introducing the CTC–16: A Command Control System You Can Build, Part 5,” *Model Railroader*, pp. 71–77, Apr. 1980.

Sperandeo, “Command Control Comparison,” *Model Railroader*, pp. 90–95, Apr. 1980.

Schleicher, “Two Train Control With Two Wires,” *Model Railroading*, pp. 48, 50–53, Oct. 1980.

Hansen, “Sound Effects Chip,” *Model Railroader*, pp. 113, Nov. 1980.

Gutierrez et al., “The CTC–16: Epilogue,” *Model Railroader*, pp. 132–134, 136, Dec. 1980.

Smallshaw, “Upgrading a Varney Dockside,” *Model Railroader*, pp. 70–71, Feb. 1981.

McGhee, “Symposium on Electronics,” *Model Railroader*, p. 109, Mar. 1981.

Hansen, “Symposium on Electronics,” *Model Railroader*, pp. 87–90, May 1981.

Hansen, “Syposium on Electronics,” *Model Railroader*, pp. 74–75, Jul. 1981.

Taylor et al., “Installing CTC–16 Receivers in Powered Diesel Units,” *Model Railroader*, pp. 72–77, Sep. 1981.

Keller Engineering, “Command Control/Sound System,” *Model Railroader*, pp. 48–49, 51–52, 54, Dec. 1981.

Thorne, “34 Electronics Projects,” *Model Railroader*, pp. 45–54, 64–71, First Edition 1982.

Smith, “Diesel Engine Sound Effect Generator,” *Model Railroader*, pp. 87–88, Mar. 1982.

- Editorial Staff, "Power Pack Performance Tests: Five Carrier/Command-Control Systems," *Model Railroading*, pp. 41-51, Apr. 1982.
- Hansen, "Symposium on Electronics," *Model Railroader*, pp. 82-83, May 1982.
- Hansen, "Symposium on Electronics," *Model Railroader*, pp. 86-87, Sep. 1982.
- Sperandeo, "Wiring the Washita & Santa Fe," *Model Railroader*, pp. 90-95, Sep. 1982.
- Sperandeo, "Command Control System," *Model Railroader*, pp. 33-35, Sep. 1982.
- Johannsen, "Onboard," *Gazette*, pp. 66-67, Sep./Oct. 1982.
- Hansen, "Electronics Symposium Correction," *Model Railroader*, pp. 148, Oct. 1982.
- Hansen, "Symposium Correction," *Model Railroader*, p. 171, Nov. 1982.
- Hansen, "Symposium on Electronics: Diesel Engine Sound-Effect Generator," *Model Railroader*, pp. 87-88, 1982.
- Keller Engineering, *Keller Steam Kit*, 1983.
- Joesten, "Bilingual Locomotive," *Railroad Model Craftsman*, pp. 98-99, Jan. 1983.
- Editorial Staff, "Operation: Carrier/Command-Control Revisited," *Model Railroading*, pp. 34-35, Jan. 1983.
- Hansen, "Symposium on Electronics," *Model Railroader*, pp. 116-117, Jan. 1983.
- Chubb, "Command Control Comes to the Sunset Valley," *Model Railroader*, pp. 103-109, Jan. 1983.
- Konrad, "Dynatrol," *Gazette*, pp. 56-58, Mar./Apr. 1983.
- Kosinski, "Carrier Control By-Pass Switch," *Railroad Model Craftsman*, pp. 114, Mar. 1983.
- Hansen, "Symposium on Electronics," *Model Railroader*, pp. 80-82, May 1983.
- Power Systems Inc., "Dynatrol Low-Profile Receiver," *Model Railroader*, May 1983.
- Kelly, "Zero 1 for N Scale," *Model Railroader*, pp. 62-65, Jul. 1983.
- North, "Installing Sound in the Grand Porter," *Gazette*, pp. 53-55, Jul./Aug. 1983.
- Hansen, "Symposium on Electronics," *Model Railroader*, pp. 97-100, Aug. 1983.
- Brewster, "Super Detailing a Pacific Coast Shay Part 3," *Model Railroader*, pp. 76-82, Oct. 1983.
- Keller Engineering, "Onboard Locomotive Sound & Control System," pp. 64, *Model Railroader*, Oct. 1983.
- Hansen, "Symposium on Electronics," *Model Railroader*, pp. 116-119, Nov. 1983.
- Keller Engineering *DH84 Addendum*, 1984.
- Keller Engineering *Instruction Manual*, "Onboard Locomotive Sound & Control System," pp. 1-89, Jan. 1984.
- Keller Engineering, "Control Keypad," *Model Railroader*, pp. 42c-42d, Feb. 1984.
- Hansen, "Symposium on Electronics," *Model Railroader*, pp. 96-98, Feb. 1984.
- Larson, "At the Throttle—Command Control: An Update," *Model Railroader*, pp. 57, Mar. 1984.
- Furlow, "Wiring the San Juan Central," *Model Railroader*, pp. 66, 68-70, Mar. 1984.
- Brown, "Momentary Contact Sound Cam," *Gazette*, pp. 48-49, Mar. 1984.
- Gutierrez, "The CTC-16e: The Next Generation of Command Control," *Model Railroader*, pp. 85-90, Apr. 1984.
- Gutierrez, "Building the CTC-16e: 2," *Model Railroader*, pp. 84-91, May 1984.
- Hansen, "Source for Sound Generator IC's," *Model Railroader*, p. 106, May 1984.
- Gutierrez, "Building the CTC-16e: 3," *Model Railroader*, pp. 68-72, Jun. 1984.
- Gutierrez, "Building the CTC-16e: 4," *Model Railroader*, pp. 66-71, Jul. 1984.
- Gutierrez, "Building the CTC-16e: Conclusion," *Model Railroader*, pp. 86-93, Aug. 1984.
- Burgess, "Layout Sound Effects: The Fourth Dimension," *Model Railroader*, pp. 88-93, Oct. 1984.
- Hansen, "Symposium on Electronics," *Model Railroader*, pp. 128-130, Nov. 1984.
- Dorsam, "Command Control . . . Is the Wiring Really All that Easy?," *NMRA*, pp. 36, Dec. 1984.
- Chubb, "The C/MRI: A Computer/Model Railroad Interface," *Model Railroader*, pp. 92-97, Feb. 1985.
- Keller Engineering, "Command Control Throttle and Sound System," *Model Railroader*, pp. 36-37, Aug. 1985.
- Hansen, "Symposium on Electronics," *Model Railroader*, pp. 82-83, Aug. 1985.
- Hediger, "Mr. Workshop," *Model Railroader*, pp. 110, 119-120, 122, Sep. 1985.
- Markovich, "Making Sound Cams Quickly," *Gazette*, pp. 22-23, Sep./Oct. 1985.
- Trammell, "PMP-112: Receivers," *Railroad Model Craftsman*, pp. 73-77, Mar. 1986.
- Trammell, "PMP-112: Introduction," *Railroad Model Craftsman*, pp. 70-77, Apr. 1986.
- Hansen, "CTC-16 Transformer Discontinued," *Model Railroader*, pp. 81, May 1986.
- Trammell, "PMP-112: Steam Sound," *Railroad Model Craftsman*, pp. 77-84, Jun. 1986.
- Wright, "Carrier/Command-Control for N Scale: Dummy Diesels to House the Receivers," *Model Railroader*, pp. 23-25, Jul. 1986.
- Hansen, "Symposium on Electronics," *Model Railroader*, pp. 111-115, Feb. 1987.
- Dorsam, "More Thoughts on Command Control," *National Model Railroad Association Bulletin*, pp. 20, Apr. 1987.
- Marklin Price List, pp. 1, 4, 5, Apr. 1987.
- Hansen, "Diesel Horn Problem," *Model Railroader*, p. 94, May 1987.
- Hansen, "Symposium on Electronics," *Model Railroader*, pp. 88-89, Aug. 1987.
- Marklin Catalog excerpts, pp. 4, 7, 10, 11, 15, 16, 17, 24, 25, 26, 27, 29, 30, 31, 100, 101, 166-176, 1987/1988.
- Marklin Price List, pp. 1, 4, Feb. 1988.
- Kamm, "CTC80 Command Control," *Model Railroader*, pp. 84-87, Mar. 1988.
- Trammell, "Phase II PMP-112 Sound System," *Railroad Model Craftsman*, pp. 86-88, Apr. 1988.
- Trammell, "Phase II PMP-112 Receiver," *Railroad Model Craftsman*, pp. 74-75, May 1988.
- Hansen, "Symposium on Electronics," *Model Railroader*, pp. 94-96, May 1988.
- Trammell, "Phase II PMP-112 Power Module," *Railroad Model Craftsman*, pp. 65-70, Jun. 1988.
- Trammell, "Phase II PMP-112 Diesel Sound Module," *Railroad Model Craftsman*, pp. 65-69, Aug. 1988.
- Robson, "A Sound Idea," *Railroad Model Craftsman*, pp. 94-96, Dec. 1988.
- Atkinson, "Symposium on Electronics," *Model Railroader*, pp. 150-151, Feb. 1989.

- Gutierrez, "Build and Authentic Diesel Horn for Your Railroad," *Model Railroader*, pp. 106–115, Feb. 1989.
- "Controlling Digital Cars," *The Digital Sig*, vol. 1, No. 2, Feb. 1989.
- Marklin Price List, pp. 1, 6, Apr. 1989.
- Burgess, "Locomotive Whistles on the Yosemite Valley RR," *Model Railroader*, pp. 68–69, Jul. 1989.
- Thompson, "Wireless Walkaround Control for the Cat Mountain & Santa Fe," *Model Railroader*, pp. 67–71, Aug. 1989.
- Marklin New Items, pp. 5, 6, 15, 1990.
- Marklin, Inc., "2-Rail Digital DC," *The Digital Sig*, vol. 2, No. 1, pp. 1,4, Jan. 1990.
- Starr Enterprises, Inc., "Sound Center," *Model Railroader*, pp. 66,68, Jan. 1990.
- Joiner et al., "Wireless Cab Control for the Great Southern," *Model Railroader*, pp. 92–95, Jan. 1990.
- Atkinson, "Waterfall Sound," *Model Railroader*, pp. 118–119, Feb. 1990.
- Marklin Price List, pp. 1, 5, Apr. 1990.
- Atkinson, "Symposium on Electronics," *Model Railroader*, pp. 102–103, May 1990.
- Stephens, "Rail Project Research, Railroad Noise," *Model Railroading*, pp. 77, May 1990.
- Dorsam, "Some Thoughts on Wiring Your Model Railroad," *NMRA Bulletin*, pp. 13, Oct. 1990.
- Marklin Catalog excerpts, pp. 61, 136–145, 1990/91.
- Marklin, Inc., "Everything Operates Digitally," *Marklin Digital*, 1990/91.
- Marklin, "A User's Guide to the Marklin Digital System," 4th Edition, pp. 20–22, 47–53, 1991.
- Roco, "Das Digital Modellbahn ABCDE," *Digital is Cool*, pp. 9, 10, 1991.
- Marklin, *Marklin Instructions*, Jan. 1991.
- Marklin Price List, pp. 1, 6, Jan. 1991.
- Keller Engineering, *Diesel/ Steam Addendum*, pp. 1–5, Jan. 31, 1991.
- Gutierrez, "The SDX–1, A Diesel Sound System You Can Build—Part 1," *Model Railroader*, pp. 88–93, Feb. 1991.
- Gutierrez, "The SDX–1, A Diesel Sound System You Can Build—Part 2," *Model Railroader*, pp. 126–130, Mar. 1991.
- Marklin, Inc., "Digital SIG" Dealer Supplement, vol. 3, No. 2, pp. 1–7, Mar. 1991.
- Gutierrez, "The SDX–1, A Diesel Sound system You Can Build—Part 3," *Model Railroader*, pp. 102–105, Apr. 1991.
- Gutierrez, "The SDX–1, A Diesel Sound System You Can Build—Part 4," *Model Railroader*, pp. 111–114, May 1991.
- Atkinson, "Sound Green Frog Tape," *Model Railroader*, pp. 105, May 1991.
- Gutierrez, "The SDX–1, A Diesel Sound System You Can Build—Part 5," *Model Railroader*, pp. 92–96, Jun. 1991.
- Marklin Digital Newsletter, vol. 3, No. 4, Jul. 1991.
- Atkinson, "Mechanical Refrigerator Car Sound," *Model Railroader*, pp. 113–114, Aug. 1991.
- Roberts, "You've Never Heard It So Good: Making Digital Recordings For Your Layout," *Railroad Model Craftsman*, pp. 89–92, Oct. 1991.
- Hediger, "Sound and Command Control System," *Model Railroader*, pp. 62–64, Oct. 1991.
- Hediger, "Ho Scale Mechanical Refrigerator Sound Unit," *Model Railroader*, pp. 66, Nov. 1991.
- Atkinson, "Op Amp Horn," *Model Railroader*, pp. 138, Nov. 1991.
- Roberts, "You've Never Heard It So Good: Part II: Two-Part Playback," *Railroad Model Craftsman*, pp. 94–96, Nov. 1991.
- Marklin Catalog excerpts, pp. 99;190–199, 284, 285, 320, 321, inside back cover, 1991/92.
- Ames, "Proposed NMRA Electrical Standard for Command Control: Status Report," *The Columbus Clinics*, pp. 131–139, 1992.
- Roberts, "You've Never Heard It So Good: Part III: Additional Features and Applications," *Railroad Model Craftsman*, pp. 89–93, Jan. 1992.
- Kendall, "Electronics—Background Sound," *N-Scale*, pp. 58–60, Jan./Feb. 1992.
- Roberts, "You've Never Heard It So Good: Part IV: Multiple Chips," *Railroad Model Craftsman*, pp. 94–95, Feb. 1992.
- Atkinson, "Symposium on Electronics," *Model Railroader*, pp. 108–109, Feb. 1992.
- Information Storage Devices, Inc. "ISD 1012A/1016/1020A Single-Chip Voice Record/Playback Devices," Feb. 1992.
- Friberg, "Magisk rostmodul for tag," *Allt om Hobby*, pp. 23–27, Mar. 1992.
- Chaudiere, "More Punch From the ISD 1016," *Railroad Model Craftsman*, pp. 81, Apr. 1992.
- "Magisk rostmodul for tag," *Allt om Hobby*, pp. 18–21, Jun. 1992.
- Montague, "Your Top Tips Ho Scale Bachman Oil Storage Tank with Horn," *Railmodel Journal*, p. 57, Jul. 1992.
- Thompson, *Fyfee Electronics Instructions Inquiry*, *Model Railroader*, pp. 131, Oct. 1992.
- Wood, "Radio Remote Control for PFM Sound Systems," *Model Railroader*, pp. 77, 79, 81, Dec. 1992.
- Marklin Catalog excerpts, E–I, pp. 78–85, 220–229, inside back cover, 1992/93.
- Walthers Catalog, *Roco excerpts*, p. 36–44, 49, 52, 1993.
- Ames, "Command Control: The Next Generation," *The Clinics at Valley Forge*, pp. 1–10, 1993.
- Thompson, "The ABC's of Command Control," *Model Railroader*, pp. 104–107, Jun. 1993.
- "What's New . . . From the NMRA," *Railroad Journal*, pp. 54, Jul. 1993.
- J.B., "Sound and Power," *CTT*, pp. 34, Jul. 1993.
- Roco catalog excerpt, pp. 4, 5, 52, 534, 1996/97.
- Thompson, "Command Control Roundup," *Model Railroader*, pp. 88–93, Jul. 1993.
- Ames et al., "Should We Have a Standard for Command Control?," *NMRA Bulletin*, pp. 29–32, Aug. 1993.
- Dorsam, "More Thoughts on Command Control," *NMRA Bulletin*, pp. 29, Sep. 1993.
- Ames et al., "New Standards Proposed for Command Control," *Model Railroader*, pp. 104–105, Oct. 1993.
- Ames, "Overview of NMRA Digital Command Control Standards," *NMRA Bulletin*, pp. 12–17, Oct. 1993.
- Sperandeo, "Steam Whistle," *Model Railroader*, pp. 42, Oct. 1993.
- Sperandeo, "Standards for Command Control?," *Model Railroader*, pp. 65, Oct. 1993.
- Garlett, "Command Control: The Debate and The Future," *Railroad Model Craftsman*, pp. 134–135, 137, Nov. 1993.
- Sprout, "ISD Sound Chips," *Railroad Model Craftsman*, p. 12, Nov. 1993.
- Thompson, "Diesel Sound System and Throttle," *Model Railroader*, pp. 51–52, 59, Nov. 1993.
- Marklin Catalog excerpts, (German Text), pp. 28, 30 32, 33, 45, 219, 225–233, inside back cover, 1993/1994.

- Roco catalog excerpts, pp. 4, 5, 52, 234, 1993/1994.
 Digital Command Control, "NMRA 94," 1994.
 Roco Price list excerpt 1994.
 Walther's Catalog, Roco excerpts, p. 62–71, 84, 1994.
 Frieberg, "Steam Whistle," *Model Railroader*, pp. 38–39, 46–67, 1994.
 Thorne, "Model Railroad Electronics," *Model Railroader*, pp. 68–75, 1994.
 Zana et al., "Digital Command Control: The Wave of the Future," *Portland*, pp. 219–229, 1994.
 West, "A Selection Guide for Digital Command Control," *Portland*, pp. 246–254, 1994.
 Thompson, "Infrared Control System Combines Sound, Throttle, and Turnout Functions," *Model Railroader*, pp. 48–51, Feb. 1994.
 Ames et al., "Standards for Digital Command Control," *NMRA Bulletin*, pp. 24–30, Feb. 1994.
 Marklin Price List, pp. 1–4, Feb. 1994.
 Loizeaux, "Digital Command Control Standards: A Non-Technical Discussion," *NMRA Bulletin*, pp. 40–42, Apr. 1994.
 Thompson, "Entry-Level Command Control System," *Model Railroader*, pp. 40–43, Jun. 1994.
 Ames, NMRA Standard S-9.2, "DDC Communications Standard," www.tttrains.com, Aug. 1994.
 Ames, NMRA Standard S-9.1, "DDC Communications Standard," www.tttrains.com, Aug. 1994.
 Palmiter, "Your Top Tips," *Railmodel Journal*, pp. 21, Sep. 1994.
 Puckett, "'Digitrax Challenger'—Entry Level Command Control Made in America," *Model Railroading*, pp. 11–13, Sep. 1994.
 Puckett, "What is DCC and What Can It Do For Me?," *Model Railroading*, pp. 64–65, Sep. 1994.
 Roco News 1995 (German Text), excerpt, pp. 1–3, 1995.
 Roco Service Replacement Parts excerpt. German Text "Ausgabe 95/09" Edition 9, 1995.
 Thompson, "Smart Controller for Command Control," *Model Railroader*, pp. 64, Jan. 1995.
 Puckett, "Digitrax's DT2000—Hand-held Computer Throttle," *Model Railroading*, pp. 16–17, Jan. 1995.
 Wilson, "Power Pack With Sound and Constant Lighting Units," *Model Railroader*, pp. 59–60, Jan. 1995.
 Editorial Staff, "Keller Digital Programmer," *NMRA Bulletin*, p. 13, Jan. 1995.
 Thompson, "QSI Sound Bloxx," *Model Railroader*, pp. 43, 47, Feb. 1995.
 Thompson, "N Scale Command Control," *Model Railroader*, Feb. 1995.
 Puckett, "WinLok 1.5 Brings Your Computer Into the Train Room," *Model Railroading*, pp. 51, Mar. 1995.
 Puthoff, "Electronics CTC Command Control," *N-Scale*, pp. 40–42, Mar./Apr. 1995.
 Marklin Digital Newsletter, vol. 6, No. 5, Sep./Oct. 1994.
 Thompson, MR Workshop—Command Control Standards, *Model Railroader*, pp. 25, Oct. 1994.
 Wilson, "Steam and Diesel Sound Generator," *Model Railroader*, pp. 40, Nov. 1994.
 Hediger, "Digital Plus Command Control Conforms to NMRA Standard," *Model Railroader*, pp. 32–33, Nov. 1994.
 Thompson, "Workshop," *Model Railroader*, pp. 30, Dec. 1994.
 Marklin Catalog excerpts, pp. 16, 22, 180, 181, 229, 234–243, 325, 330, 332, 338, 339, 345, 347, 349, 379, inside back cover, 1994/95.
 Rocco Catalog excerpts, 1994/95.
 L.G.B., Instruction Manual, pp. 6–9, 1995.
 Rocco Price list excerpt 1995.
 Walther Catalog, Rocco excerpts 1995.
 Kendall, "Electronics—Diesel Train Horn," *N-Scale*, pp. 51–55, Mar./Apr. 1995.
 Atkinson, "Using Sound Chips On Your Layout," *Model Railroader*, pp. 118–119, May 1995.
 PSI, Dynatrol Mini Instruction, Jun. 1995.
 Hediger, "Diesel Sound System," *Model Railroader*, pp. 39–40, Jun. 1995.
 Watson, "Digitrax Decoder Installation," *N-Scale*, pp. 58–59, Jul./Aug. 1995.
 Thompson, "SystemOne Command Control System," *Model Railroader*, pp. 42–44, Aug. 1995.
 Providenza, "Ballast Lamps and Power Sections for Digital Command Control," *Railroad Model Craftsman*, pp. 77–78, Sep. 1995.
 J.W., "Steam Sound System," *Model Railroader*, pp. 39, Sep. 1995.
 Puckett, "Model Railroading Takes a Closer Look at Digital Command Control," *Model Railroading*, pp. 18–22, Sep. 1995.
 Puckett, "EasyRamp—The Easy Way to Program DCC Decoders," Sep. 1995.
 Watson, "Digitrax Big Boy Digital Command Control System," *N-Scale*, pp. 44–45, Sep./Oct. 1995.
 Puckett, "Model Railroading Takes a Closer Look at Digital Command Control—Part II," *Model Railroading*, pp. 38–39, Oct. 1995.
 Bonham, "Computers and the Modeler, 5.0," *Railroad Model Craftsman*, pp. 72–74, Oct. 1995.
 Sperandio, "Command Control Today," *Model Railroader*, pp. 69, Oct. 1995.
 Puckett, "Model Railroading Takes a Closer Look at Digital Command Control—Part III," *Model Railroading*, pp. 33–35, Nov. 1995.
 Loizeaux, "A DCC Discussion," *Railroad Model Craftsman*, pp. 82–85, Nov. 1995.
 Puckett, "WinLok 2.0 Brings New Functionality to DCC," *Model Railroading*, pp. 57, Dec. 1995.
 Puckett, "Planning a System to Meet Your Needs—Part IV," *Model Railroading*, pp. 27–29, Dec. 1995.
 Marklin Catalog excerpts, pp. 10, 284–293, 382–385, 406, 407 inside back cover, 1995/96.
 Roco Alpin Line Catalog excerpts, pp. 8, 9, 26–29, 1995/96.
 L.G.B., "1996 News: The latest on new LGB trains and accessories for 1996," catalog, 1996.
 Walther's Catalog, Roco excerpts, pp. 61–69, 86–89, 1996.
 Puckett, "Software Updates and DCC on the Web," *Model Railroading*, pp. 46, Jan. 1996.
 Gutierrez, "Life-like SD7 Command Control Light Problems," *Model Railroader*, pp. 30, Jan. 1996.
 Hediger, "Steam and Diesel Sound System," *Model Railroading*, pp. 50–51, 54, Jan. 1996.
 Puckett, "Visit the Cumbres and Toltec on CD," *Model Railroading*, pp. 52–53, Feb. 1996.
 Bacus, Jr., "Observation Car," *NMRA Bulletin*, pp. 11, Feb. 1996.
 Gruber, "The Reading Lines Goes DCC," *NMRA Bulletin*, pp. 19–21, Feb. 1996.

- Puckett, "Model Railroading Takes a Closer Look at Digital Command Control—Part V," *Model Railroading*, pp. 34–37, Mar. 1996.
- Schaumburg, "DCC?," *Railroad Model Craftsman*, pp. 110–112, Apr. 1996.
- Puckett, "Programming DCC Decoders with Digitrax's PR1," *Model Railroading*, pp. 62–63, Apr. 1996.
- Hermanson, "DCC Forum," *Railroad Model Craftsman*, pp. 6–7, Apr. 1996.
- Verner, "A Carload of Sound," *Model Railroader*, pp. 88–89, Jun. 1996.
- Barry, "Sound for Layouts," *Mainline Modeler*, pp. 58–60, Jul. 1996.
- Puckett, "Model Railroading's Continuing Look at Digital Command Control—Part IV," *Model Railroading*, pp. 10–12, Jul. 1996.
- Loizeaux, "What you Need to Know About DCC," *Railroad Model Craftsman*, pp. 80–81, Jul. 1996.
- Johnston, "In Command of Control," *Railroad Model Craftsman*, pp. 82–84, Jul. 1996.
- Loizeaux, "What You Need to Know About DCC," *Railroad Model Craftsman*, pp. 76–79, Jul. 1996.
- Martin, "SystemOne DCC System: All Scales," *Railroad Model Craftsman*, pp. 89–93, Jul. 1996.
- Roco catalog excerpt, pp. 4, 5, 52, 234, 1996/97.
- Barry, "Sound for N Scale Layout," *N-Scale*, pp. 43–45, Jul./Aug. 1996.
- Atkinson, "Electronics Symposium World Wide Web Sites of Interest," *Model Railroader*, pp. 109, Aug. 1996.
- Freitag, "Dynatrol Infrared Wireless Throttle," *Model Railroader*, pp. 38–39, Sep. 1996.
- Ames, "How Compatible is DCC?," *Model Railroader*, pp. 92–93, Oct. 1996.
- Sebastian-Coleman, "Steam and Sound System for Digital Command Control and Conventional DC," *Model Railroader*, pp. 41, 47–48, Oct. 1996.
- Cabrall, "Installing DCC Decoders in Small Steam Locomotives," *Railroad Model Craftsman*, pp. 71–72, Oct. 1996.
- Mansfield, "DCC and the JWRR," *Model Railroading*, pp. 49–50, Oct. 1996.
- Puckett, "Model Railroading Takes a Look at What's New in DCC for 1997 Part VII," *Model Railroading*, pp. 38–43, Nov. 1996.
- LGB, *The World Of LGB Catalog*, 1996/1997.
- Roco, Product Catalog "Digital is Cool, n.d." pp. 5, 8–9, 35–41, 86, 310–311, 1996/1997.
- Walthers Catalog, Roco excerpts, pp. 64–72, 92–95, 216, 1997.
- Russinger, "Hobby Shop Counter Sound Traxx," *NMRA Bulletin*, pp. 14, Jan. 1997.
- Goslett, "Digital Command Control System: All scales," *Railroad Model Craftsman*, pp. 95, 104, 106, 108, Jan. 1997.
- Sperandeo, "Good News in Chicago," *Model Railroader*, pp. 79, Jan. 1997.
- Marklin Digital Newsletter, vol. 9, No. 1, Jan./Feb. 1997.
- Wilson, "MRC's New Command 2000 Digital Command Control Is An Easy-to-Use System," *Model Railroader*, pp. 36–37, Feb. 1997.
- Gutierrez et al., "The EasyDCC Command Control System: 1," *Model Railroader*, pp. 86–93, Feb. 1997.
- Edwards, "Digitrax Chief Digital Command Control System: All scales," *Railroad Model Craftsman*, pp. 98, 100, 102–103, Feb. 1997.
- Sperandeo, "Digital Command Control You Can Build," *Model Railroader*, pp. 69, Feb. 1997.
- Gutierrez et al., "The EasyDCC Command Control System: 2," *Model Railroader*, pp. 84–89, Mar. 1997.
- NMRA Recommended Practices RP-9.21: Extended Packet Formates For Digital Command Control, All Scales, Mar. 1997.
- Marklin Digital Newsletter, vol. 10, No. 2, Mar./Apr. 1997.
- Gutierrez et al., "The EasyDCC Command Control System: 3," *Model Railroader*, pp. 80–85, Apr. 1997.
- Gutierrez et al., "The EasyDCC Command Control System: 4," *Model Railroader*, pp. 94–102, May 1997.
- Puckett, "Model Railroading Takes a Look at DCC Decoders Part VIII," *Model Railroading*, pp. 38–43, May 1997.
- Hediger, "Walkaround Throttle for MRC Digital Command Control System," *Model Railroader*, pp. 37, 39, Jun. 1997.
- Gutierrez et al., "The EasyDCC Command Control System: 5," *Model Railroader*, pp. 82–89, Jun. 1997.
- Gutierrez et al., "The EasyDCC Command Control System: 6," *Model Railroader*, pp. 94–96, Jul. 1997.
- Sebastian-Coleman, "DCC-Compatible Onboard Sound System," *Model Railroader*, pp. 39–40, Jul. 1997.
- Edwards, "DCC Lighting for a Dash-9," *Railroad Model Craftsman*, pp. 48–51, Jul. 1997.
- Puckett, "Model Railroading Takes a Look at DCC Decoder Installations Part IX," *Model Railroading*, pp. 34–39, Aug. 1997.
- G.S.C., "Load-Compensating DCC Decoders," *Model Railroader*, pp. 39–40, Sep. 1997.
- Coleman, "Digital Command Control Decoder with Steam Sound," *Model Railroader*, pp. 36, Sep. 1997.
- Puckett, "Model Railroading Takes a Look At DCC Decoder Installations—Part X," *Model Railroader*, pp. 32–37, Oct. 1997.
- Thompson, "Running Trains with Computers," *Model Railroader*, pp. 108–109, Oct. 1997.
- Atkinson, "Refrigerator Sound Circuit," *Model Railroader*, pp. 127, Nov. 1997.
- Puckett, "Dallee's Newest Sound Releases," *Model Railroading*, pp. 17, Nov. 1997.
- Mansfield, "Installing Digital Command Control on a Home Layout—Part 1: DCC," *Model Railroading*, pp. 66–69, Nov. 1997.
- Kelly, "DCC, What it is and What it Does," *Model Railroader*, pp. 88–89, Nov. 1997.
- Puckett, "Model Railroading Takes a Look at DCC Decoder Installations Part XI," *Model Railroading*, pp. 31–34, Nov. 1997.
- Pitts, "DCC Digital Command Control," *N Scale* pp. 30–34 Nov./Dec. 1997.
- Kellner, "Wiring the Wisconsin Central," *Model Railroader*, pp. 112–115, Dec. 1997.
- Mansfield, "Installing Digital Command Control on a Home Layout Part 2," *Model Railroading*, pp. 50–51, 53–54, Dec. 1997.
- Marklin Catalog Excerpts, pp. 384–385, 418, 435, 437, 439, 447, 451, inside back cover, 1997/1998.
- Ames et al., "Digital Command Control: A Comprehensive guide to DCC," *Allt om Hobby AB*, pp. 2, 16, 17, 58, 63, 70–72, 116–117, 122–123, 1998.
- Marklin Insider Special Edition: Marklin Digital, pp. 2, 7–9, 13–19, 82, 83, 1998.
- Friberg, "Model Railroad Electronics 2," *Allt om Hobby AB*, pp. 2, 9, 15, 24–25, 57, 1998.

SoundTraxx, Digital Sound Decoder Technical Reference, Rev B 1998.

Sound Traxx, Sound Traxx Owners and Tech Manual and Diesel Addendum, 1998.

Sebastian-Coleman, "Transformer Case and Power Supply," *Model Railroader*, pp. 43-44, Feb. 1998.

Ernst Paul Lehmann Patentwerk, "Explore the World of LGB," Product Book, Chapter 8, pp. 95-103, Sep. 1998.

Marklin, Marklin/Digital Newsletter, vol. 10, No. 6, Nov./Dec. 1998.

Goodenough, "IC Holds 16 Seconds of Audio Without Power," *Electronic Design*, Jan. 31, 1999.

Koester, "Trains of Thought—The Power of Sound," pp. 121, *Model Railroader*, May 1999.

Ames and Lord, e-mail messages of statements made to Patent and Trademark Office, Jul. 13, 1999.

Lord, Letter to Mattson, Esq. with enclosures, Aug. 19, 1999.

Ames, Letters to Patent and Trademark Office, Aug. 20, 1999.

Marklin Website downloaded information (digital comparison HTML), www.marklin.com, pp. 1, 1-3. Aug. 2001.

Electronic Solutions Ulm, "Digital Command Control with Original Sound," www.loksound.de, pp. 1-3, 1, 2, 1, May 2003.

Jayant, Nikil: "Signal Compression: Technology Targets and Research Directions" *IEEE Journal on Selected Areas in Communications*, vol. 10, No. 5, Jun. 1992, pp. 796-818.*

NMRA Recommended Practices RP-9.2.1: Extended Packet Formats For Digital Command Control, All Scales, Mar. 1997.*

* cited by examiner

FIG. 1

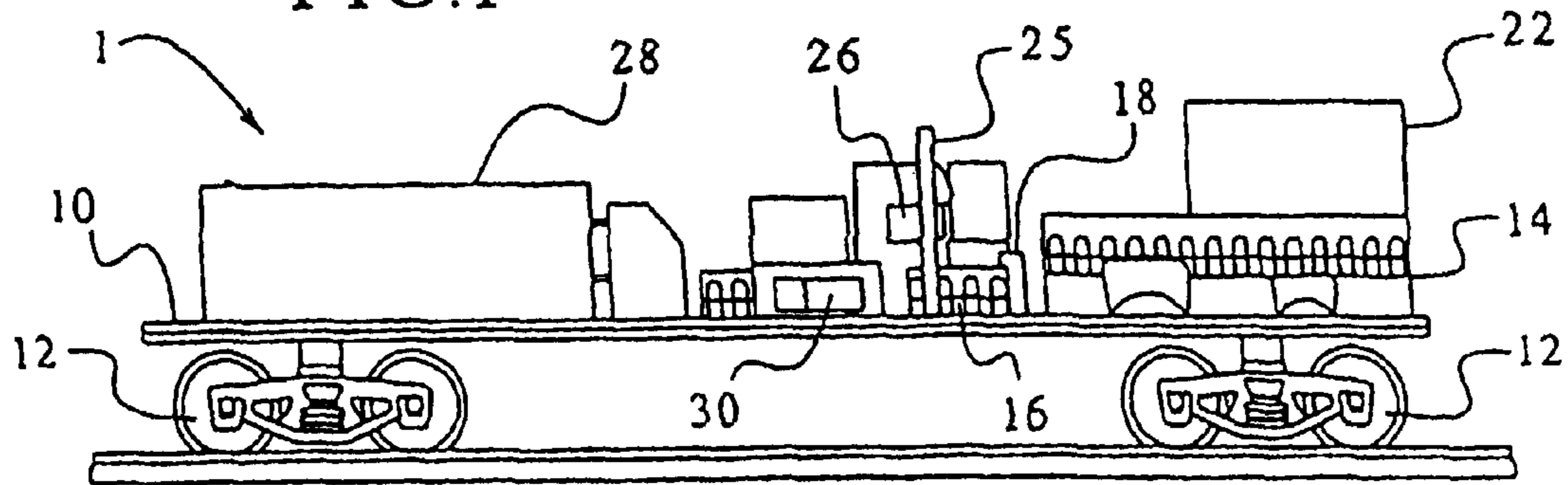

FIG. 2

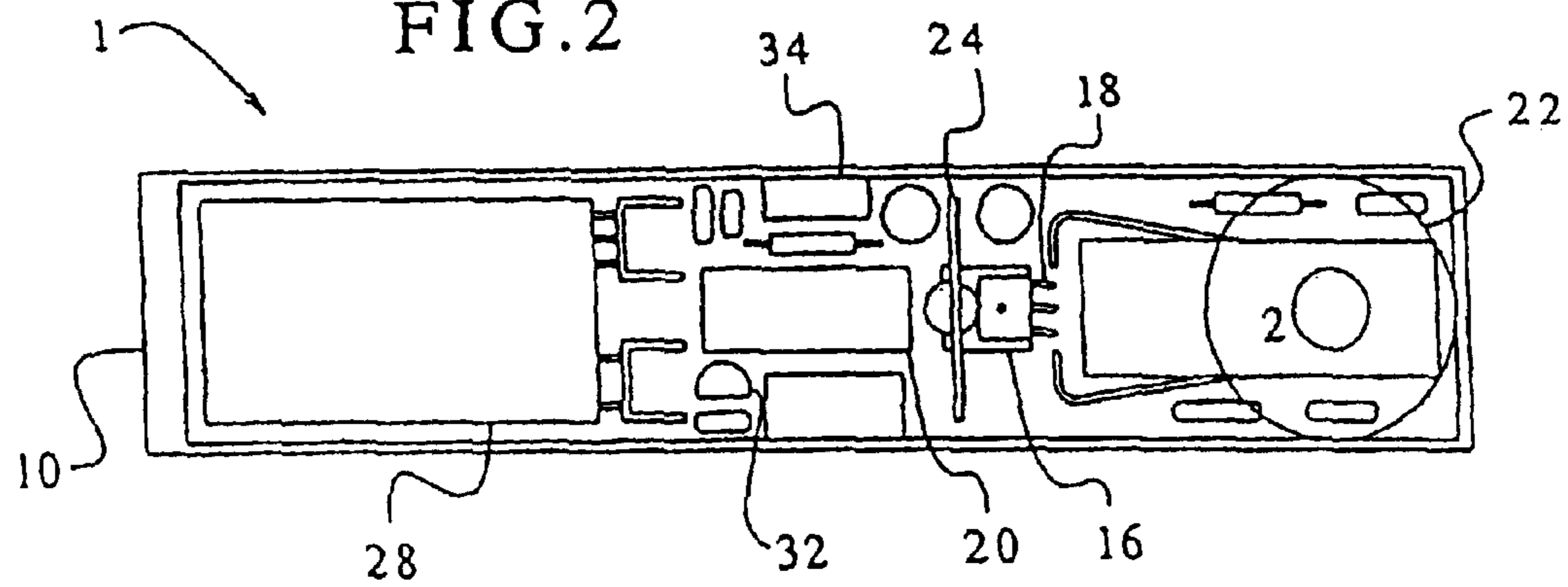
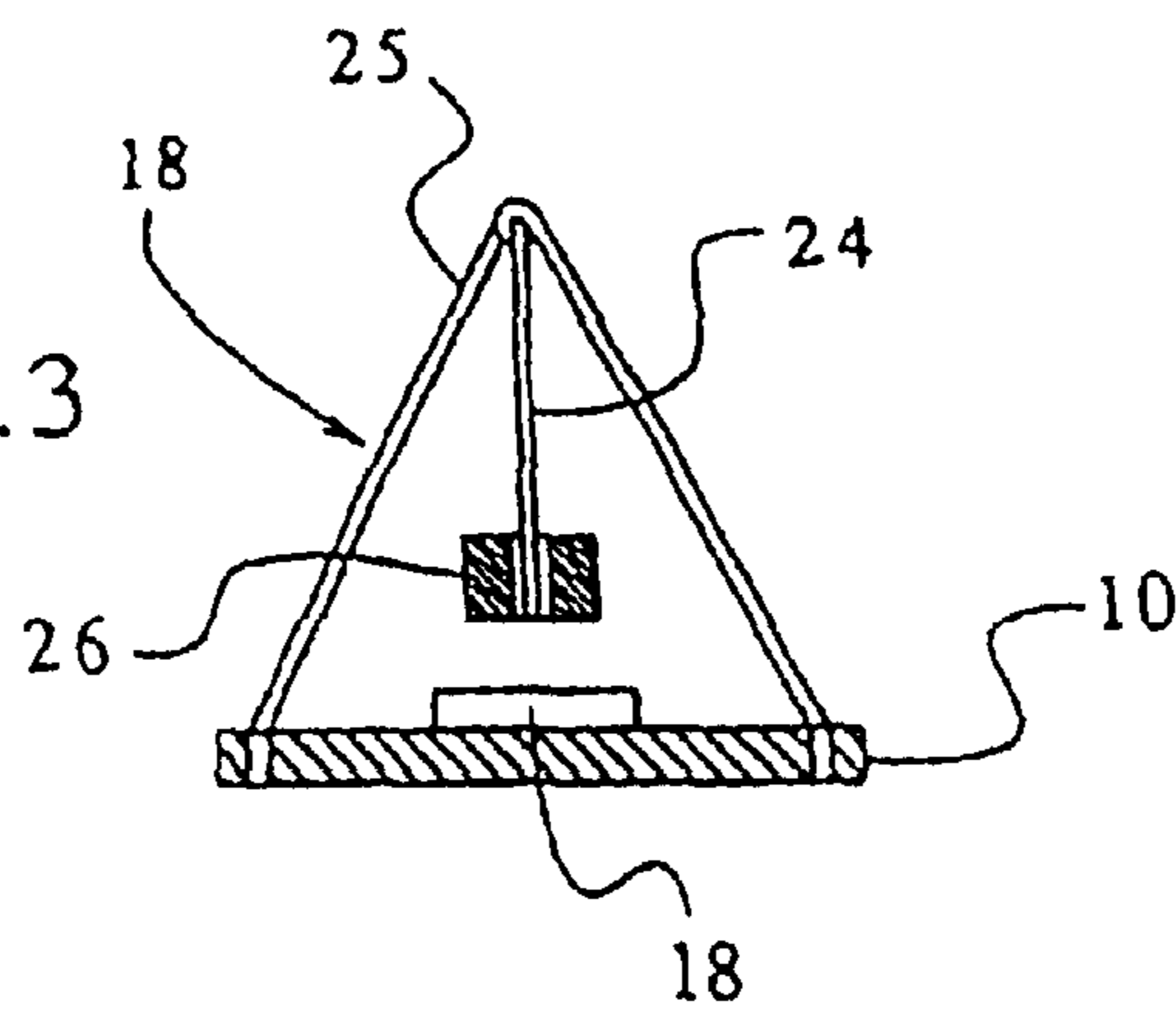
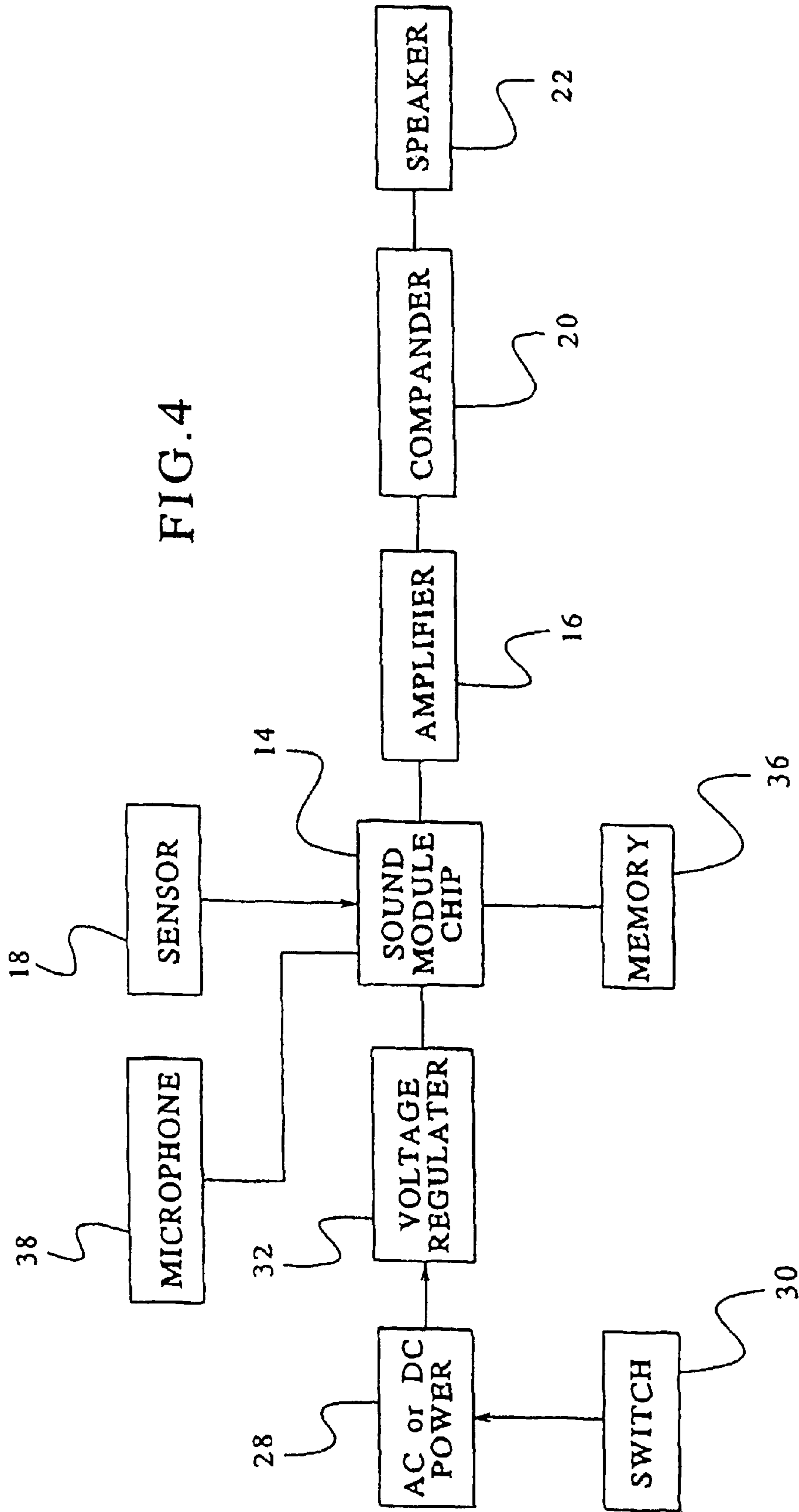
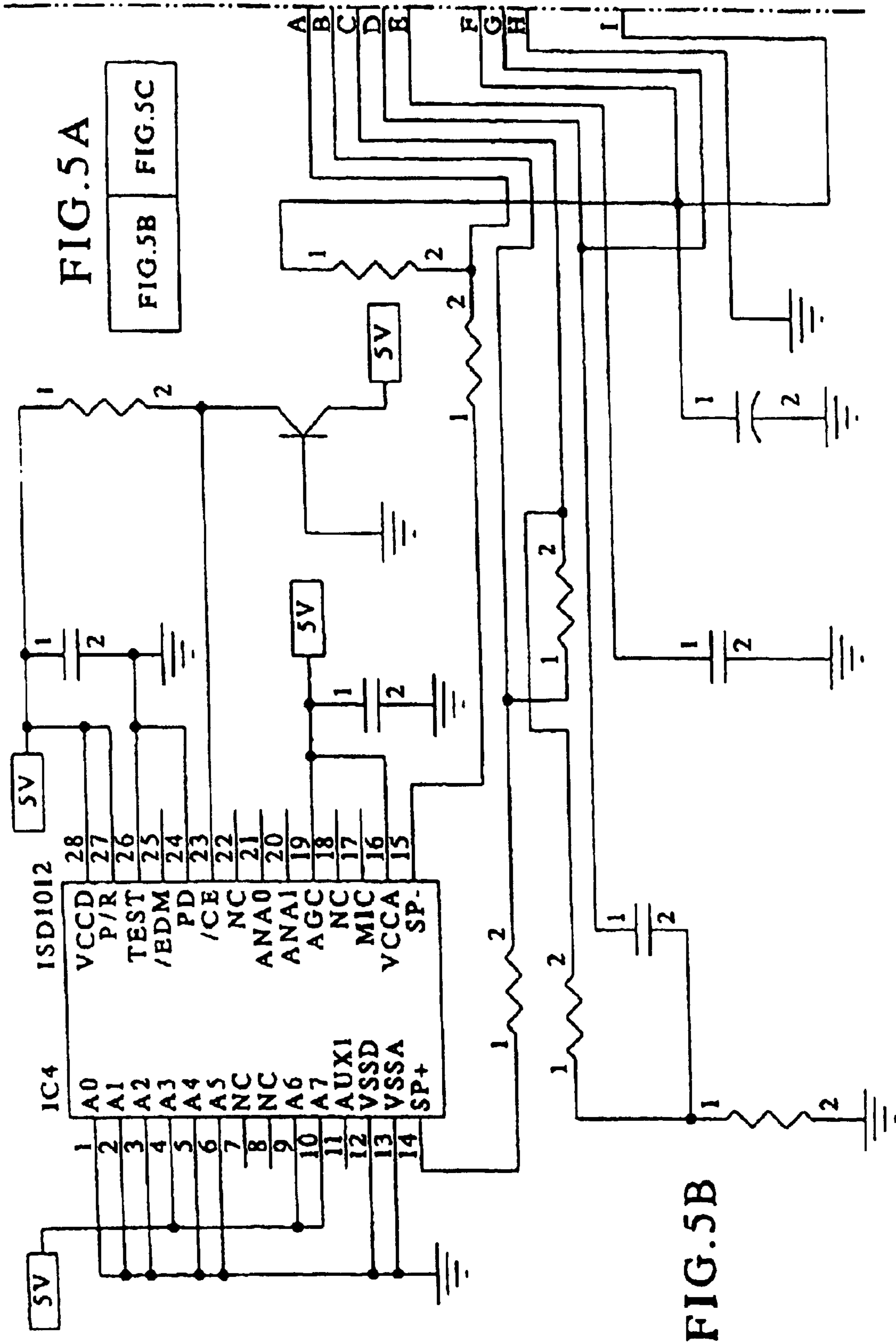

FIG. 3







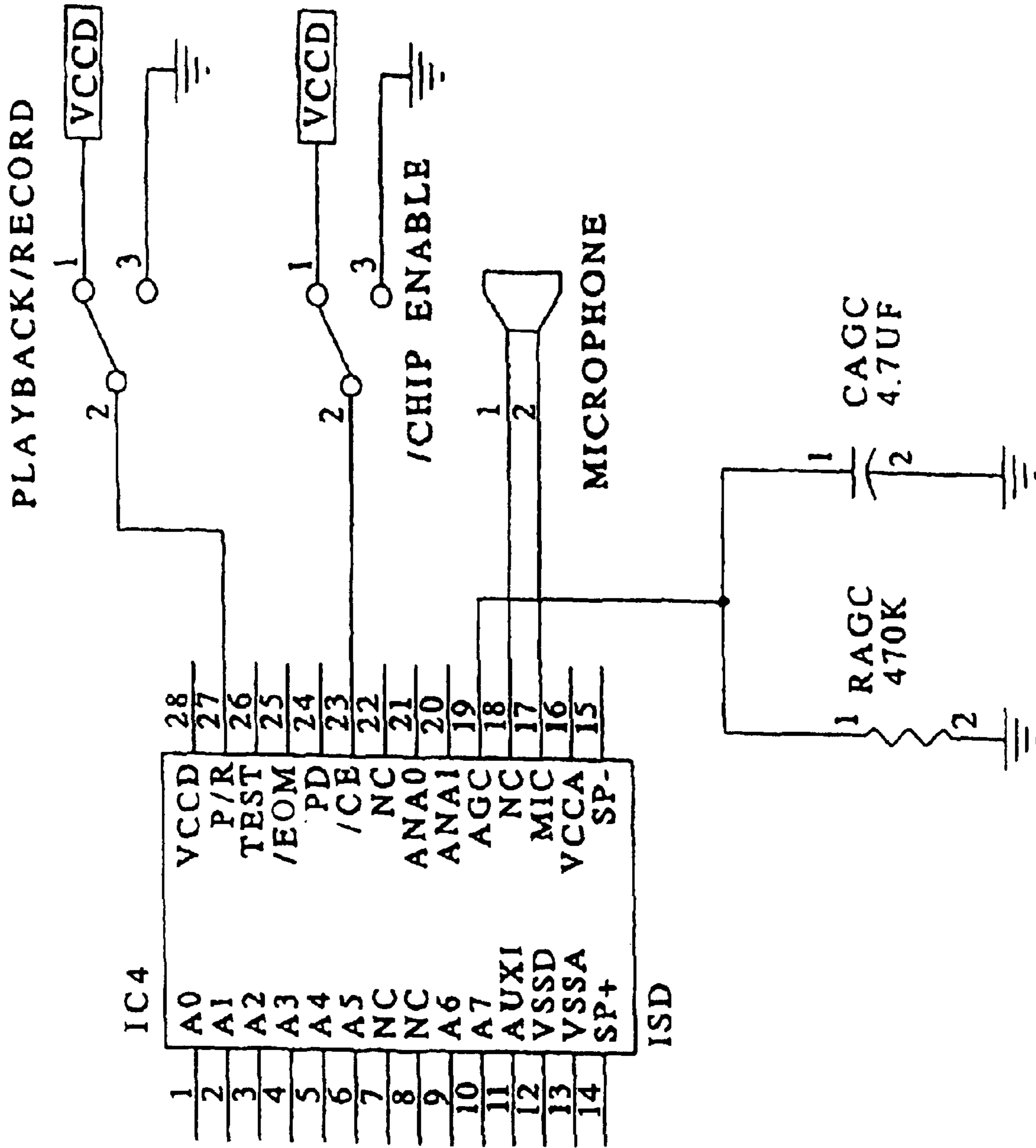
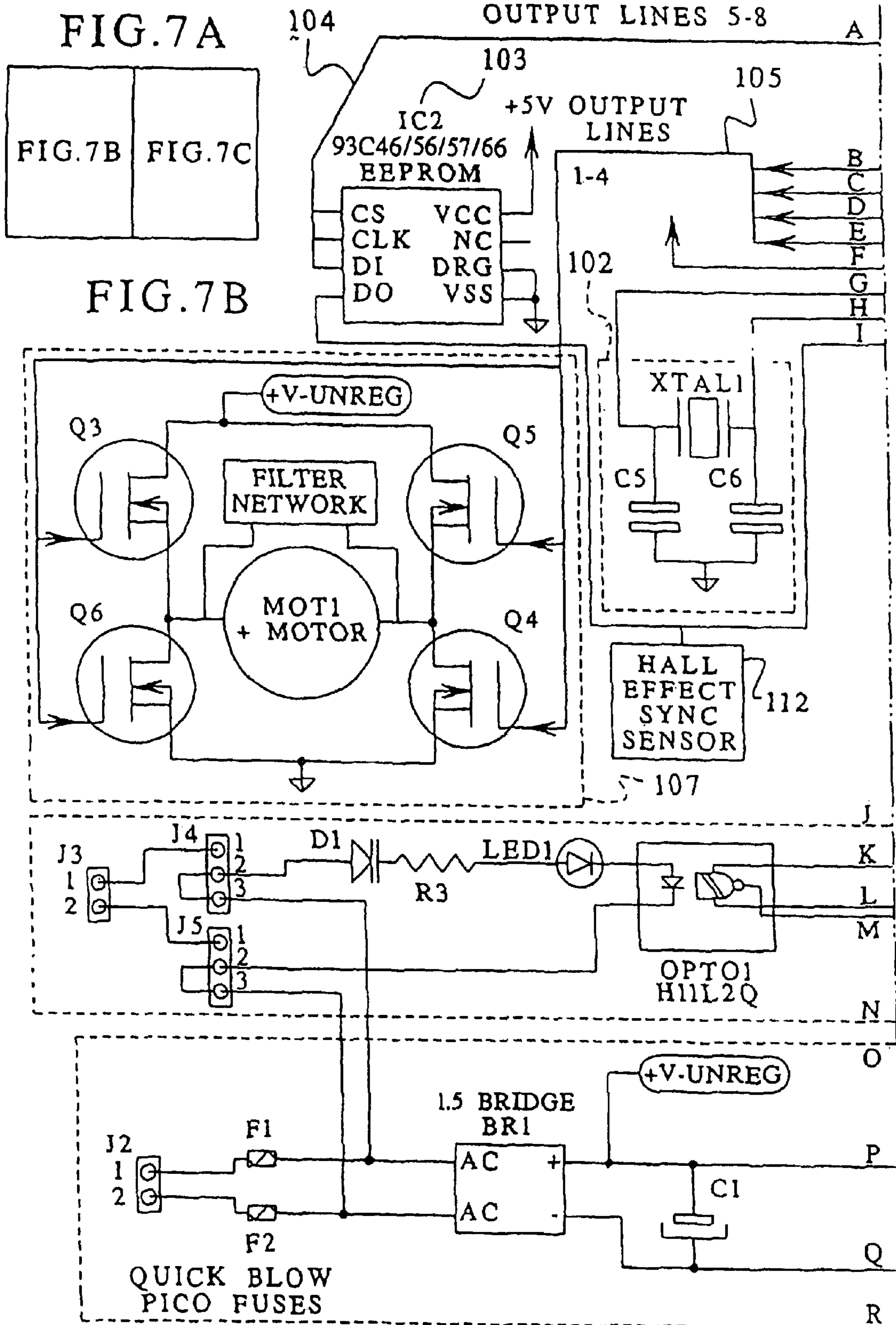
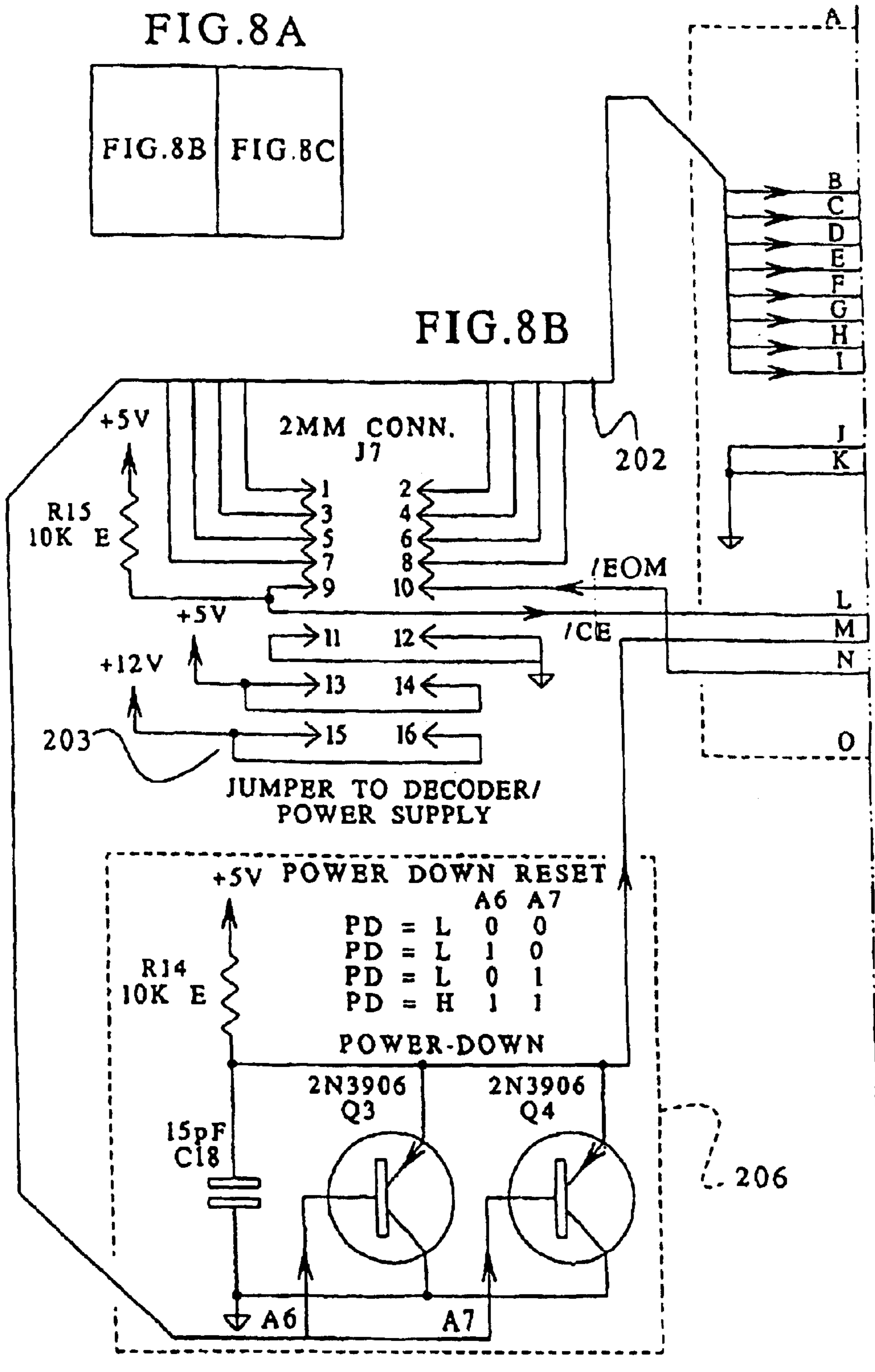

FIG. 6





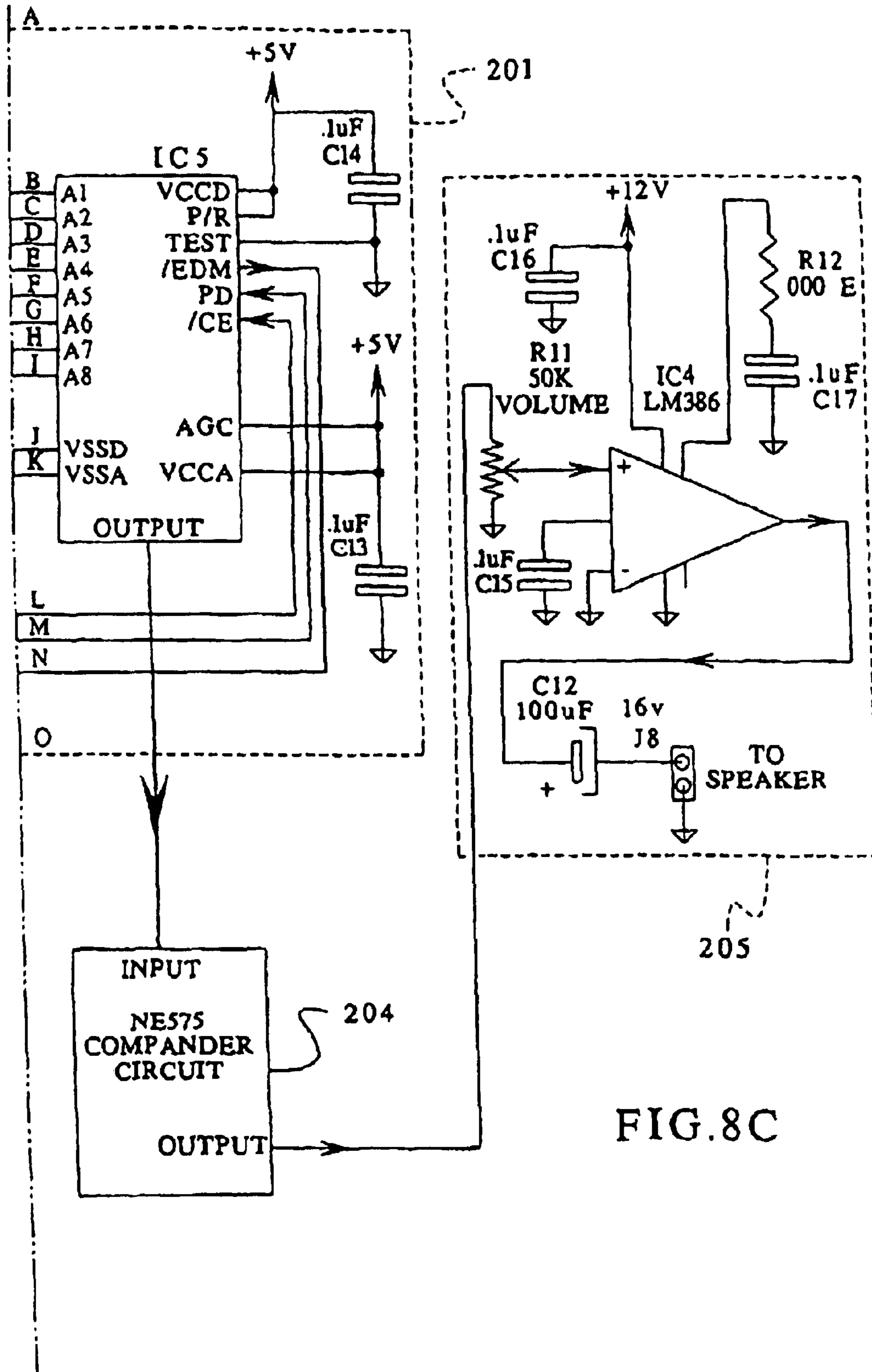

FIG. 8C

FIG.9A

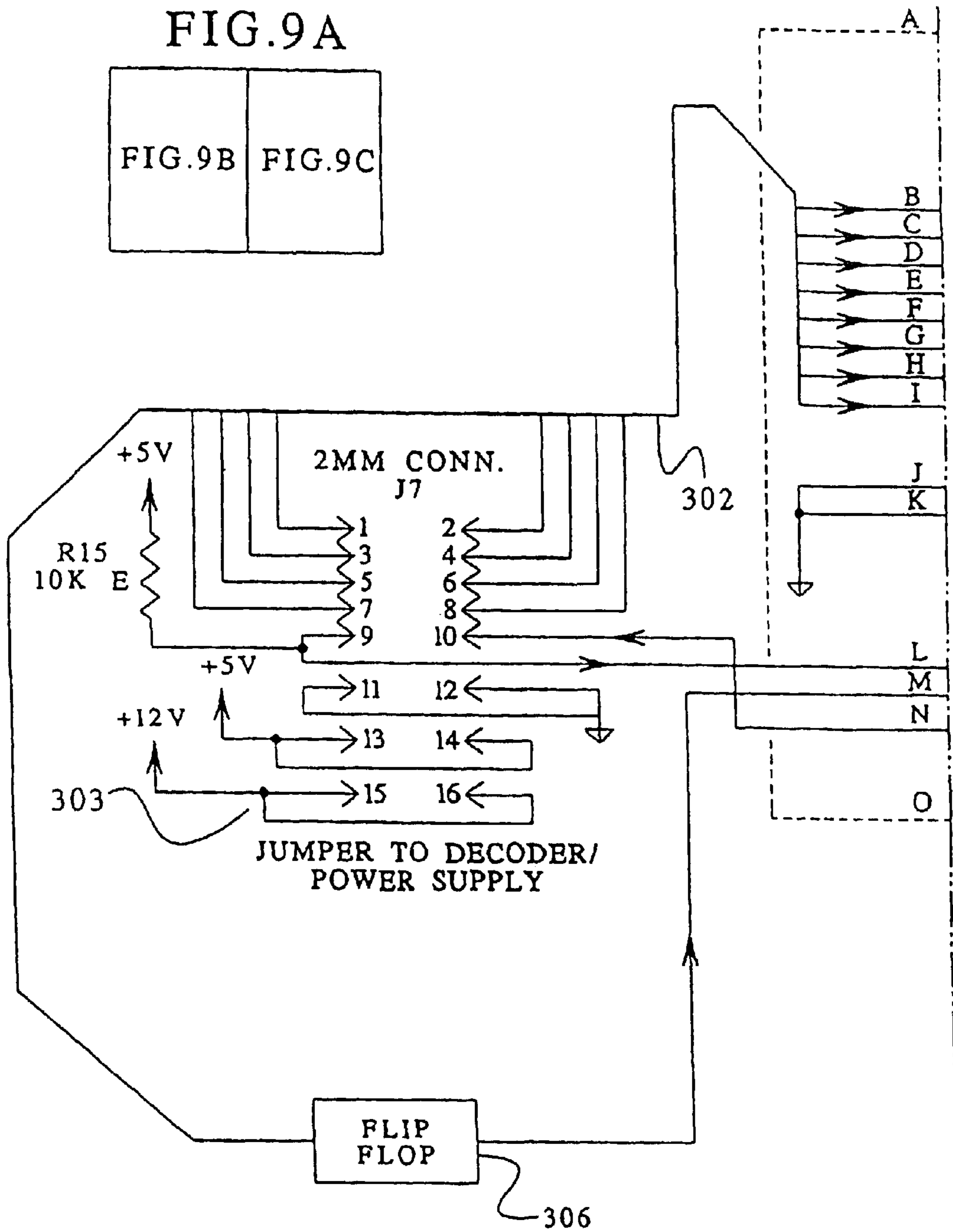

FIG.9B

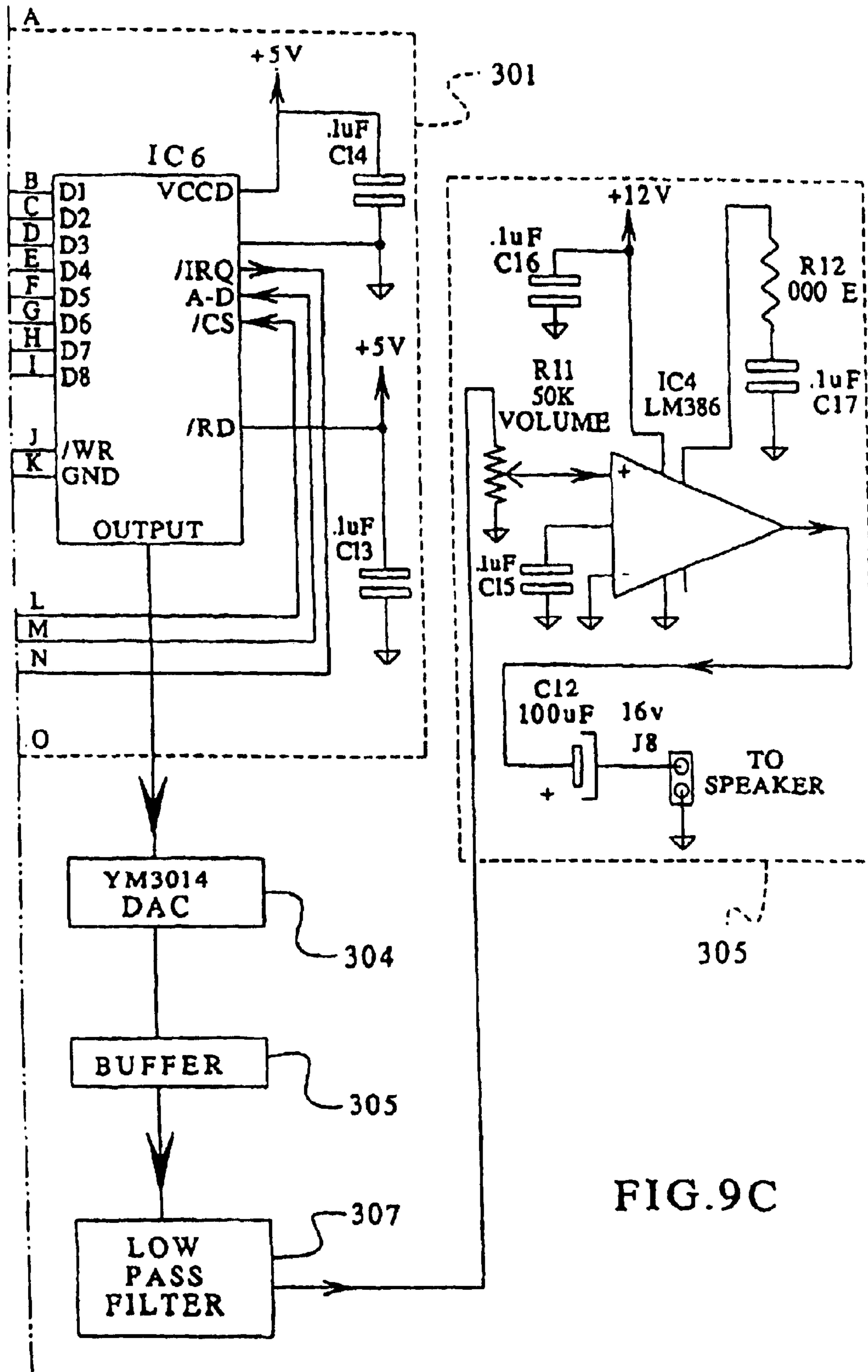

FIG. 10

DCC BASELINE PACKET 401
I = 58us (52us-64us) 402
0 > 100us (90us-10000us) 403

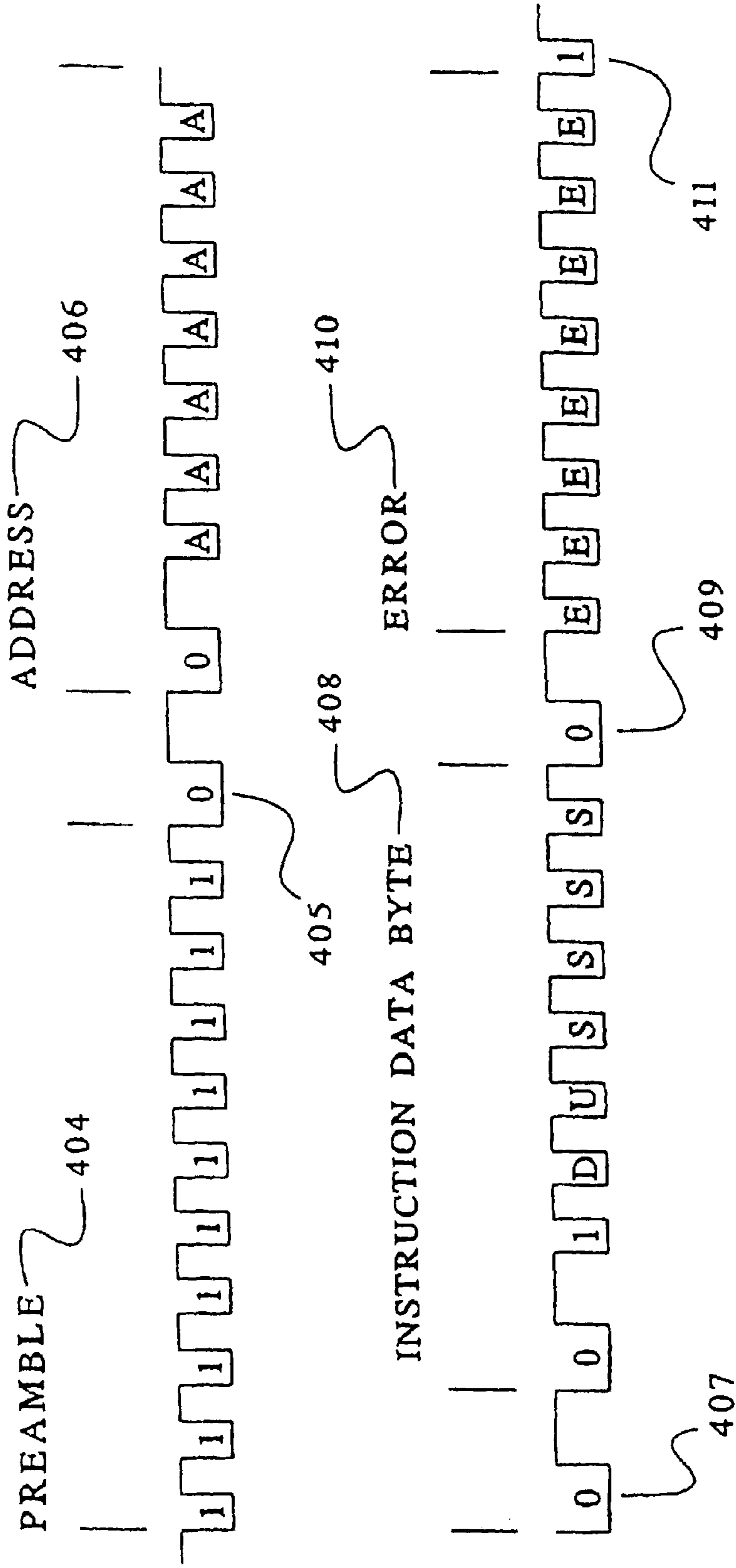

FIG. 11

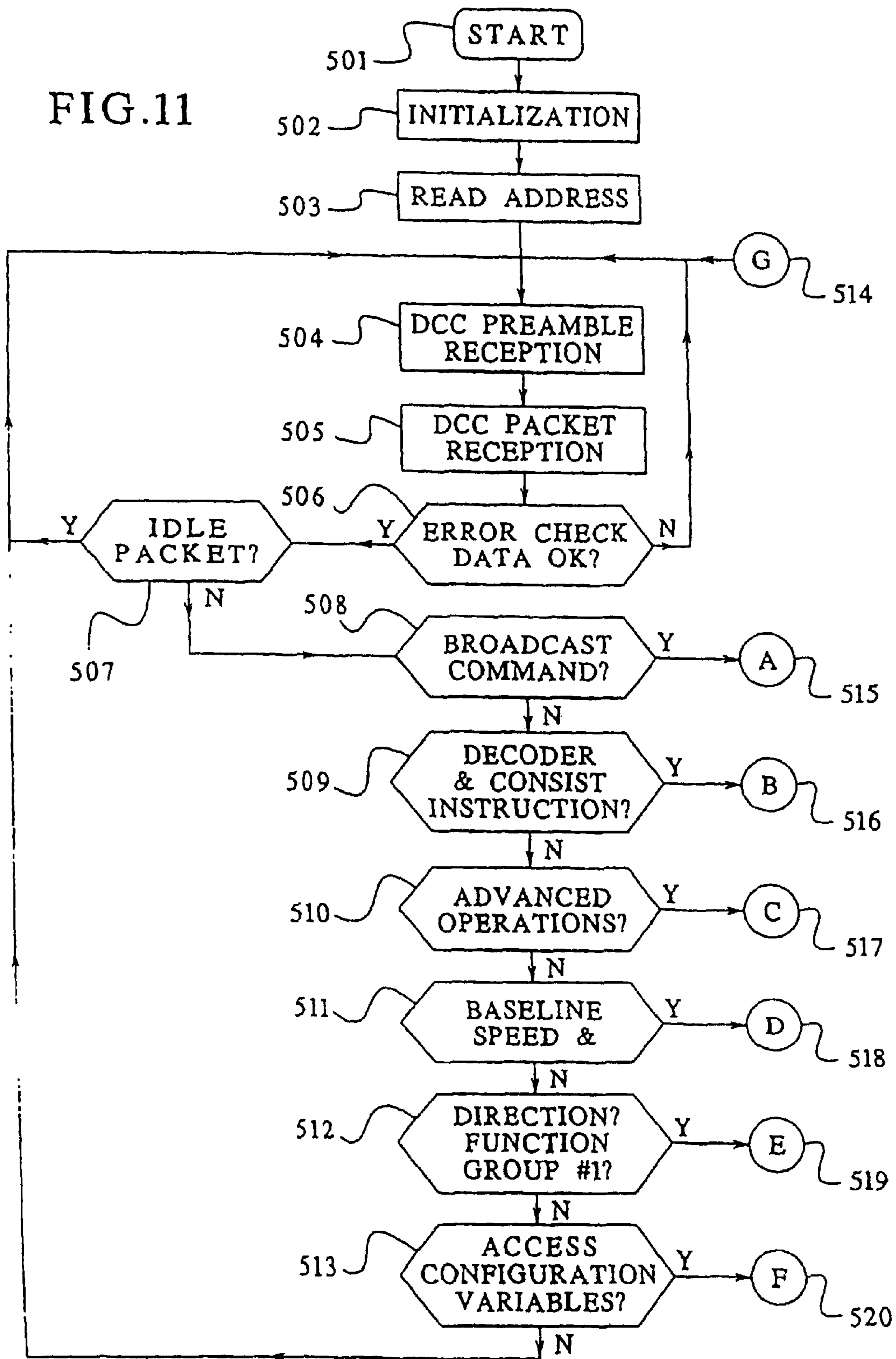

FIG.12

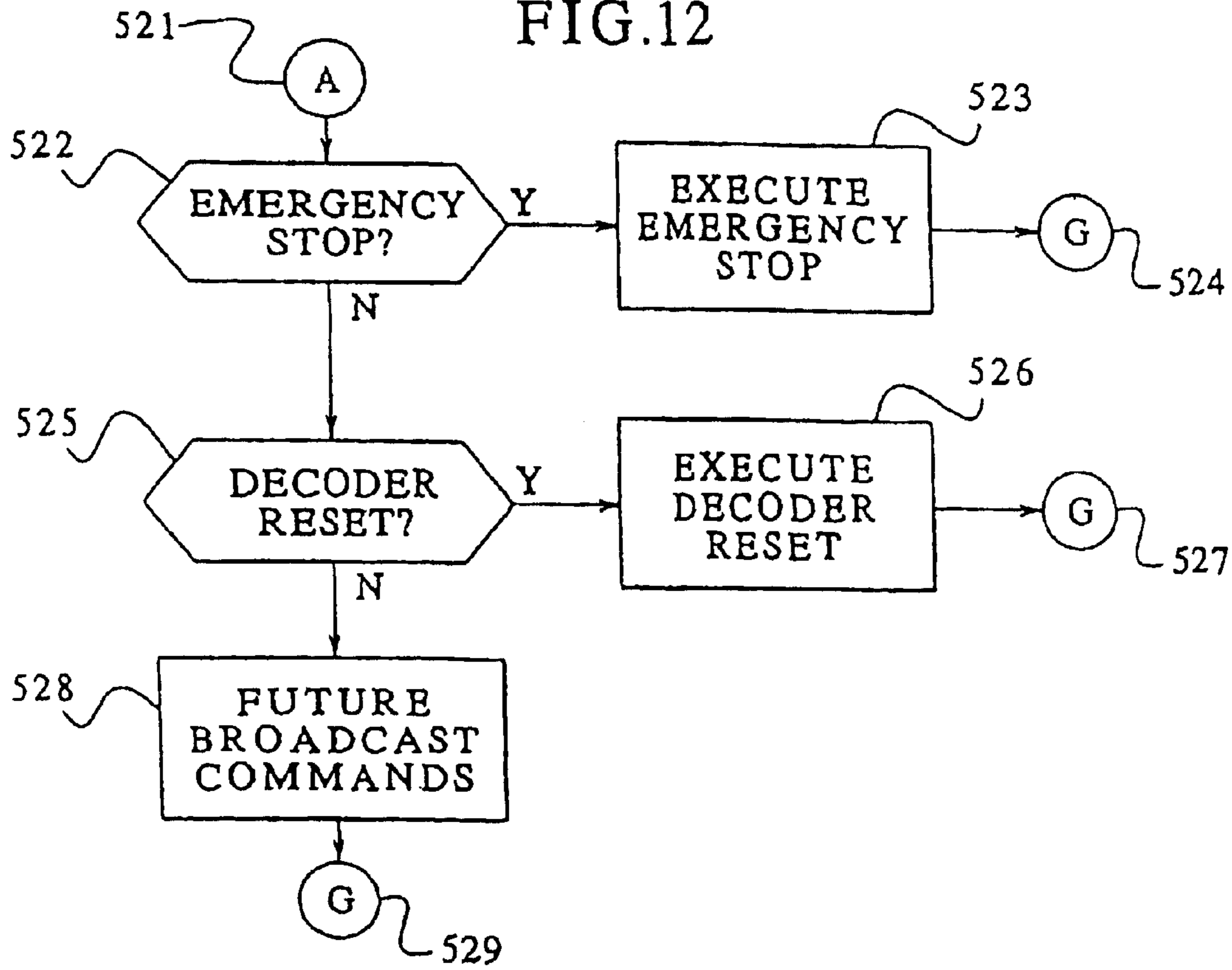
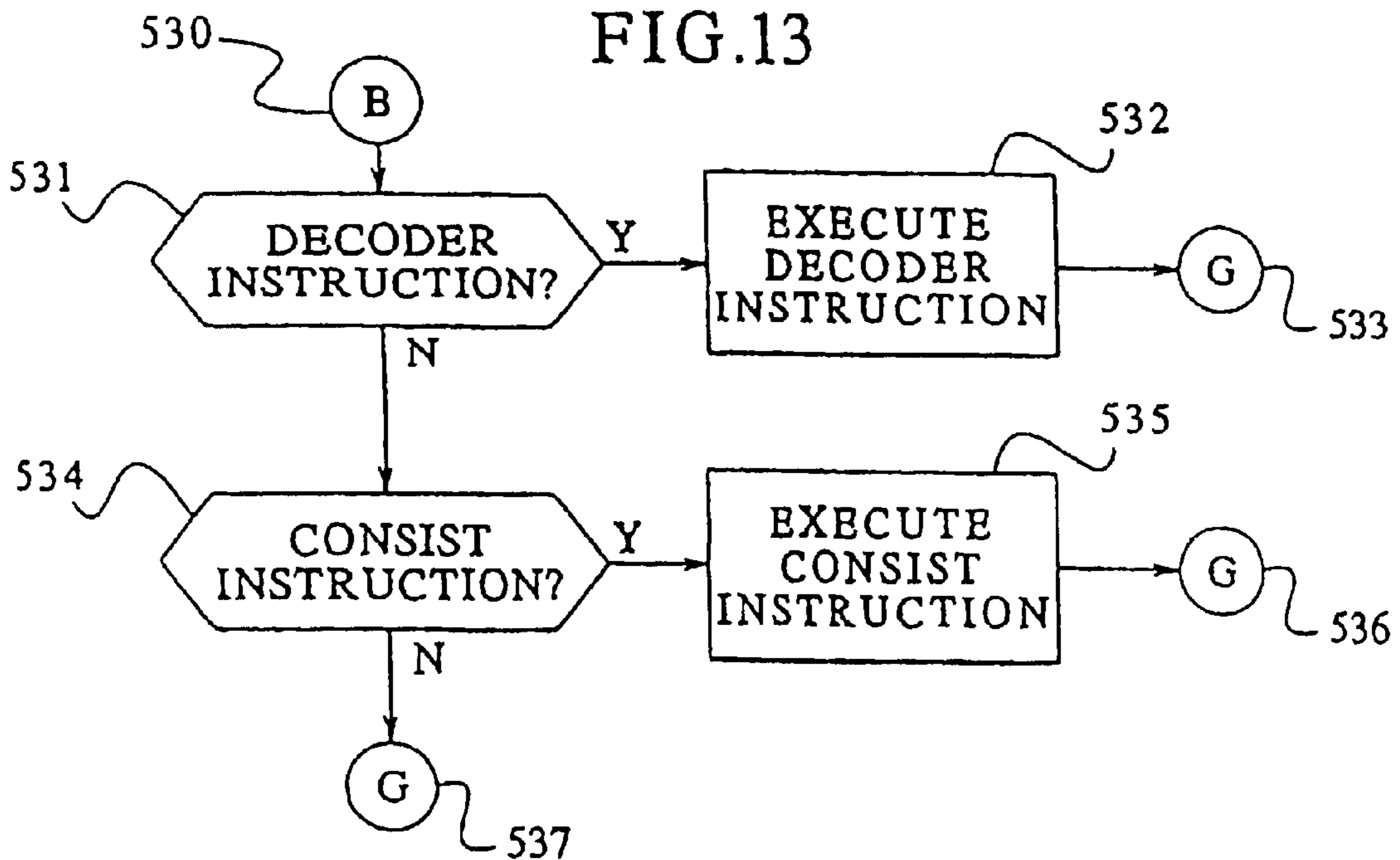

FIG.13



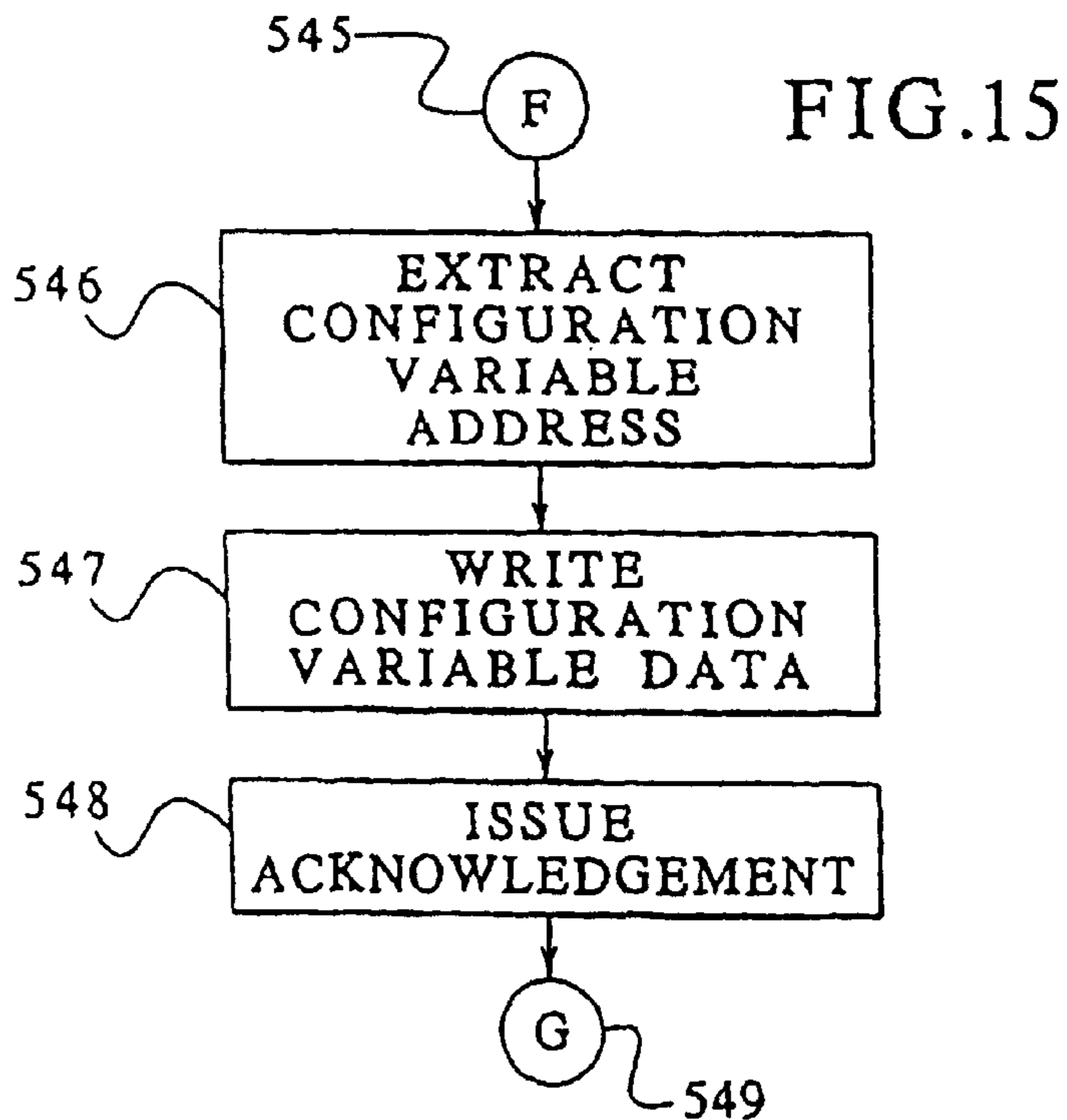
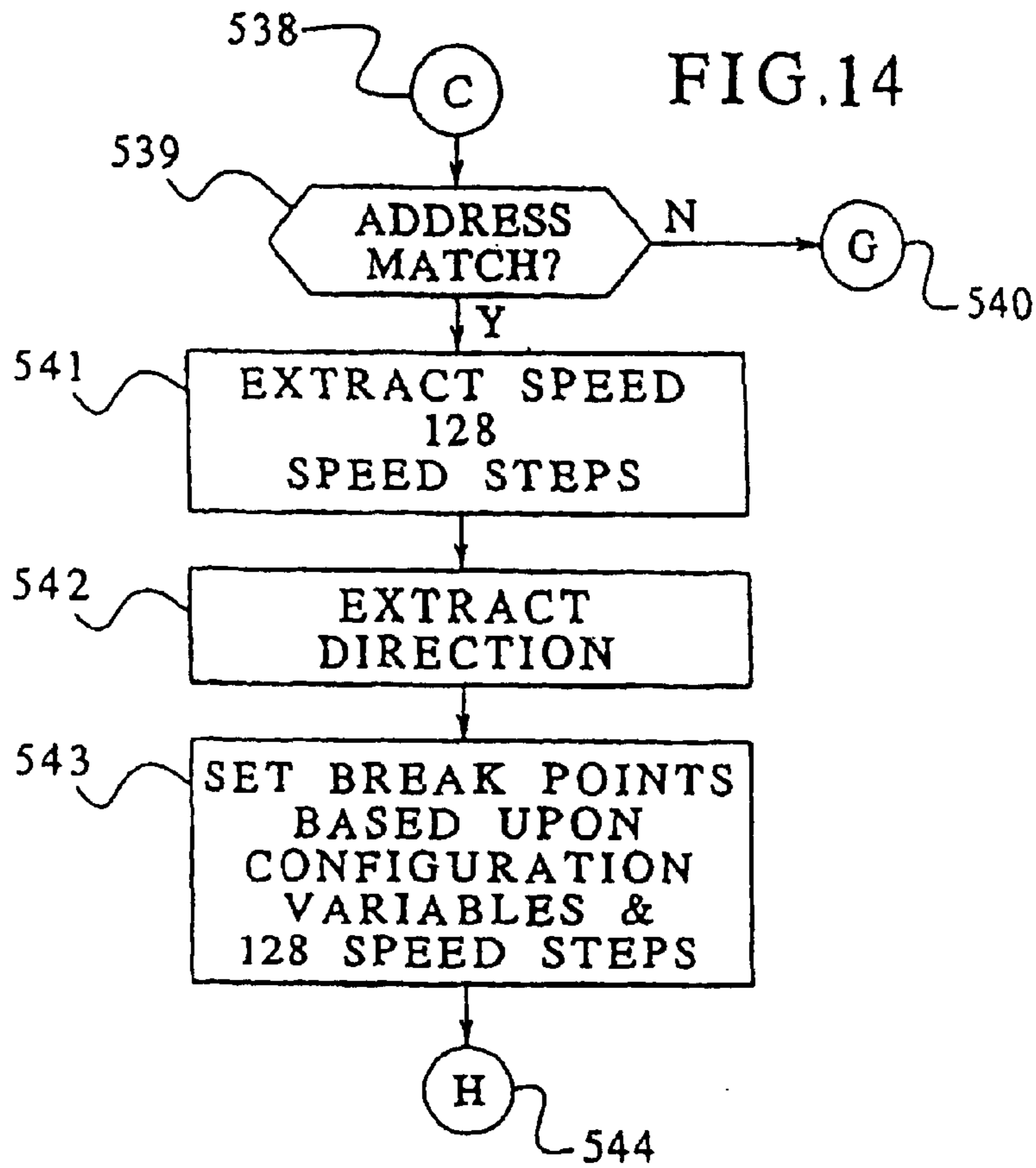

FIG.16

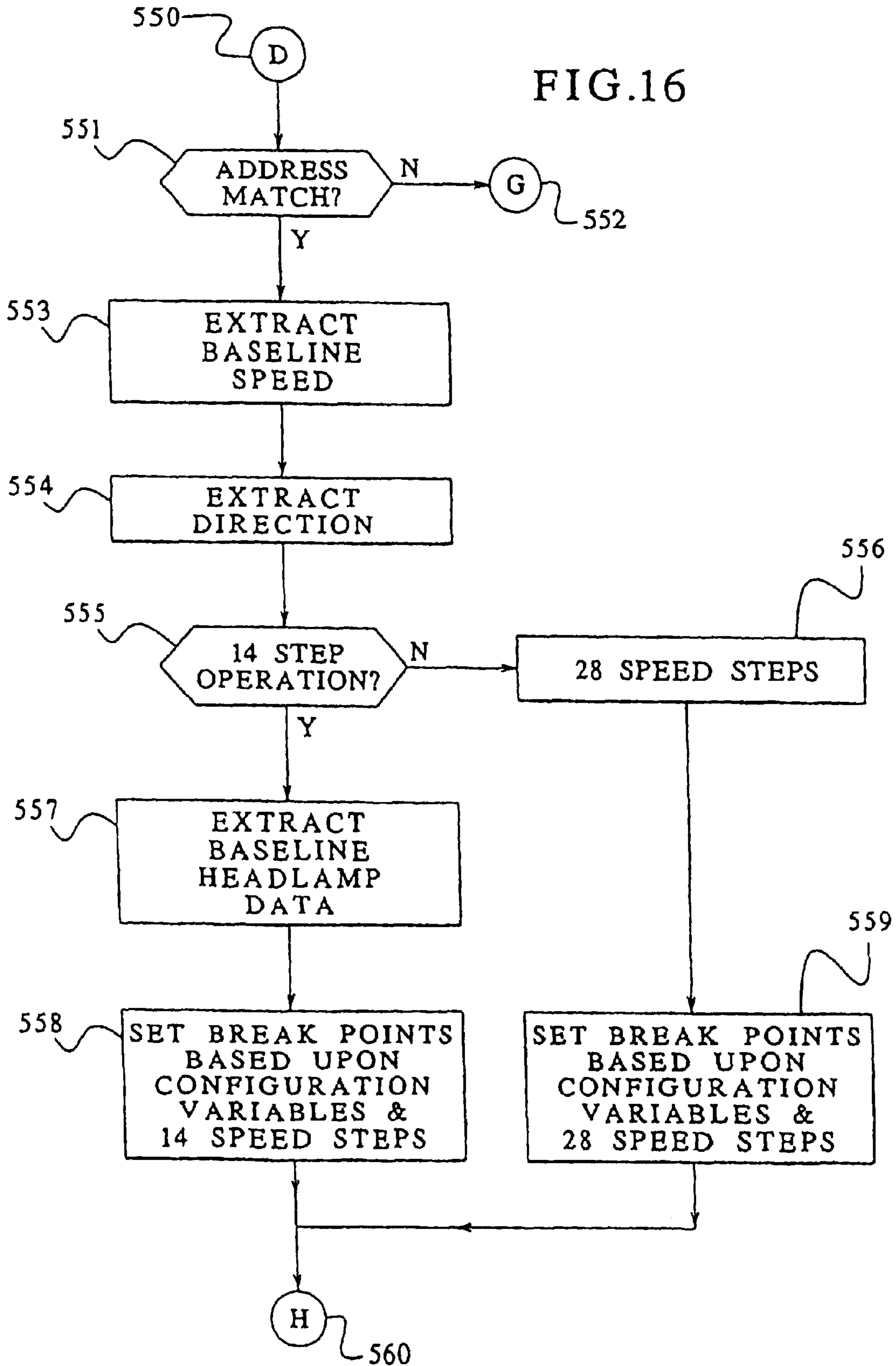

FIG.17

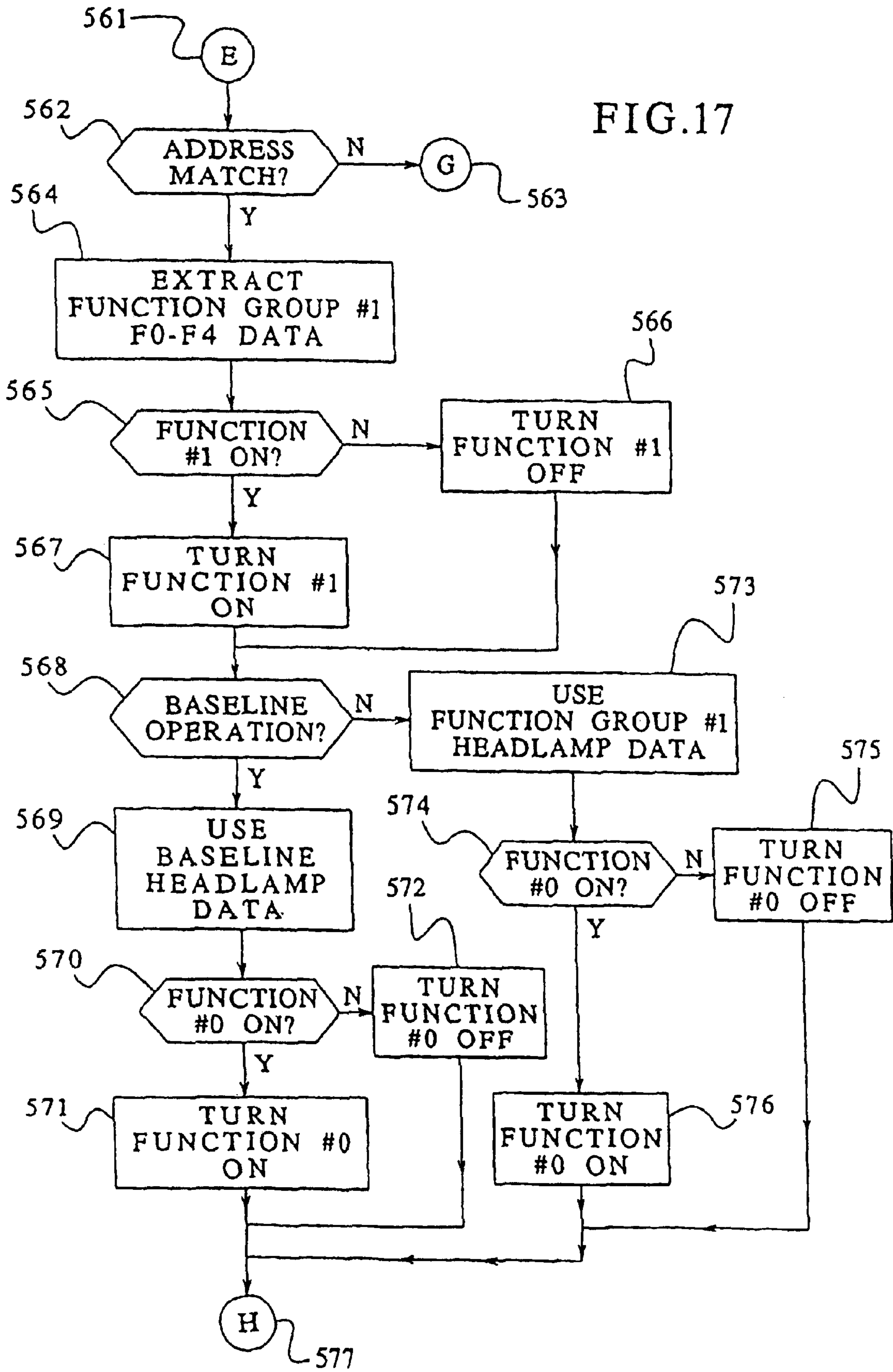
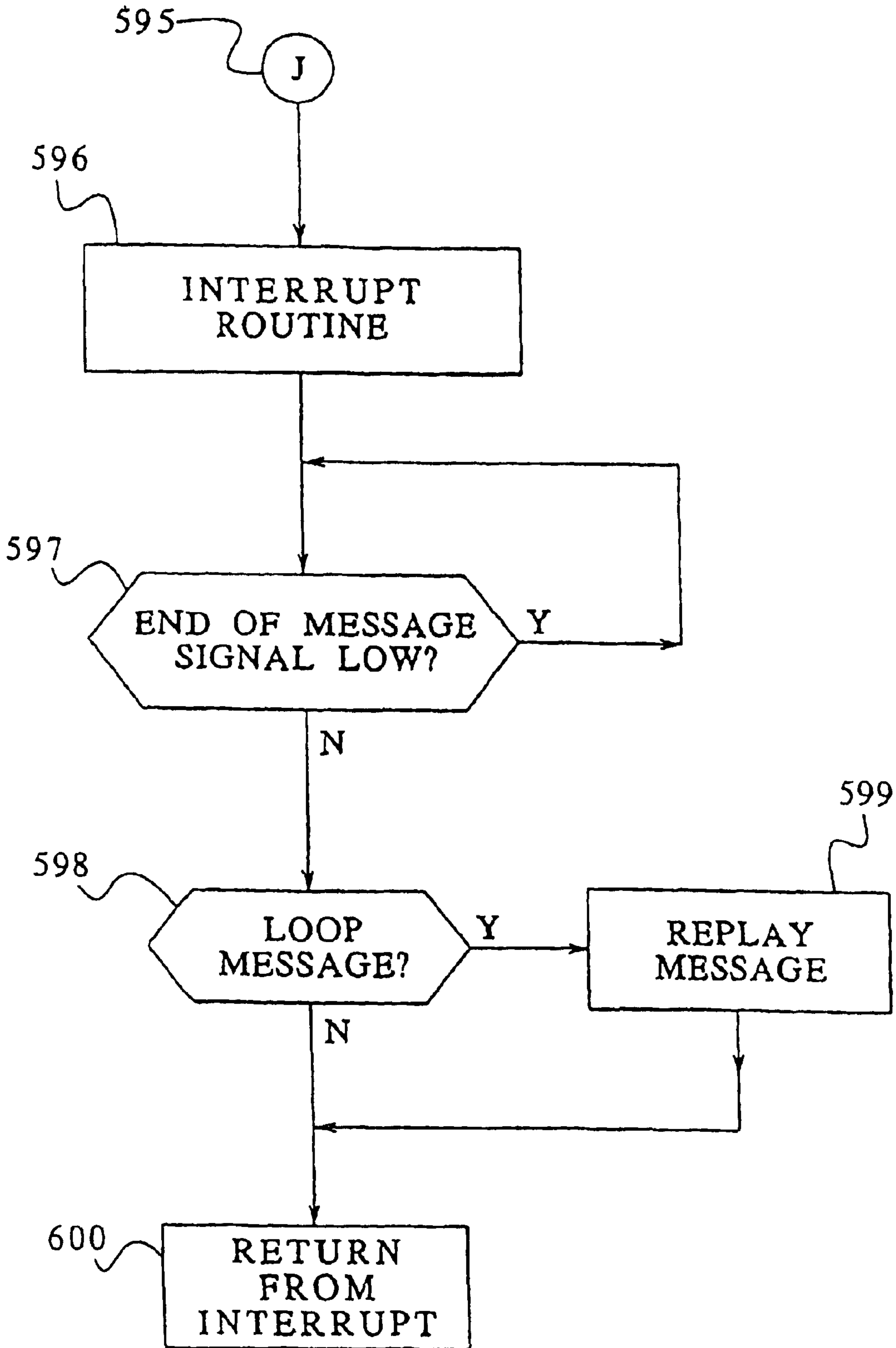

FIG. 18



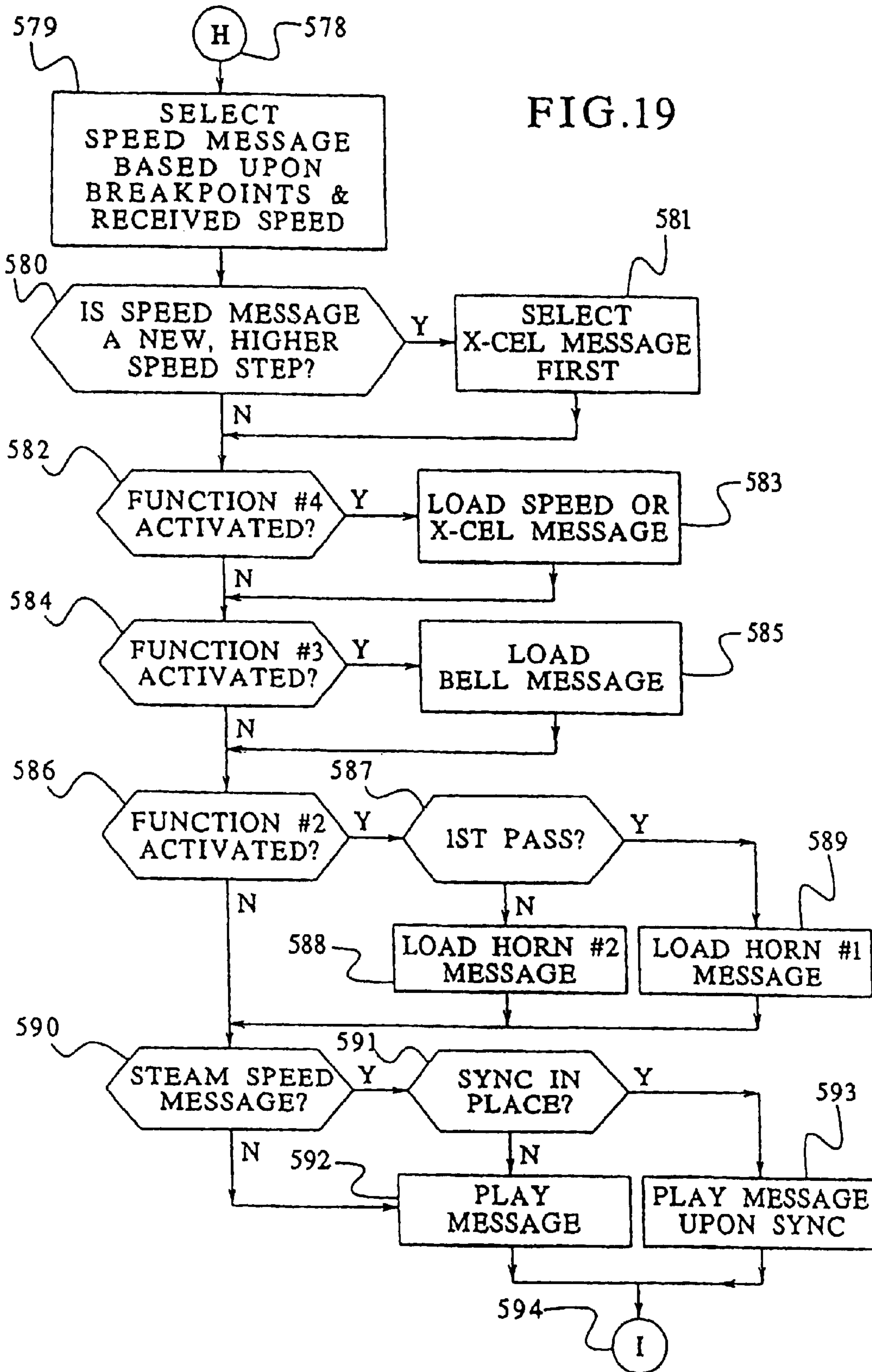
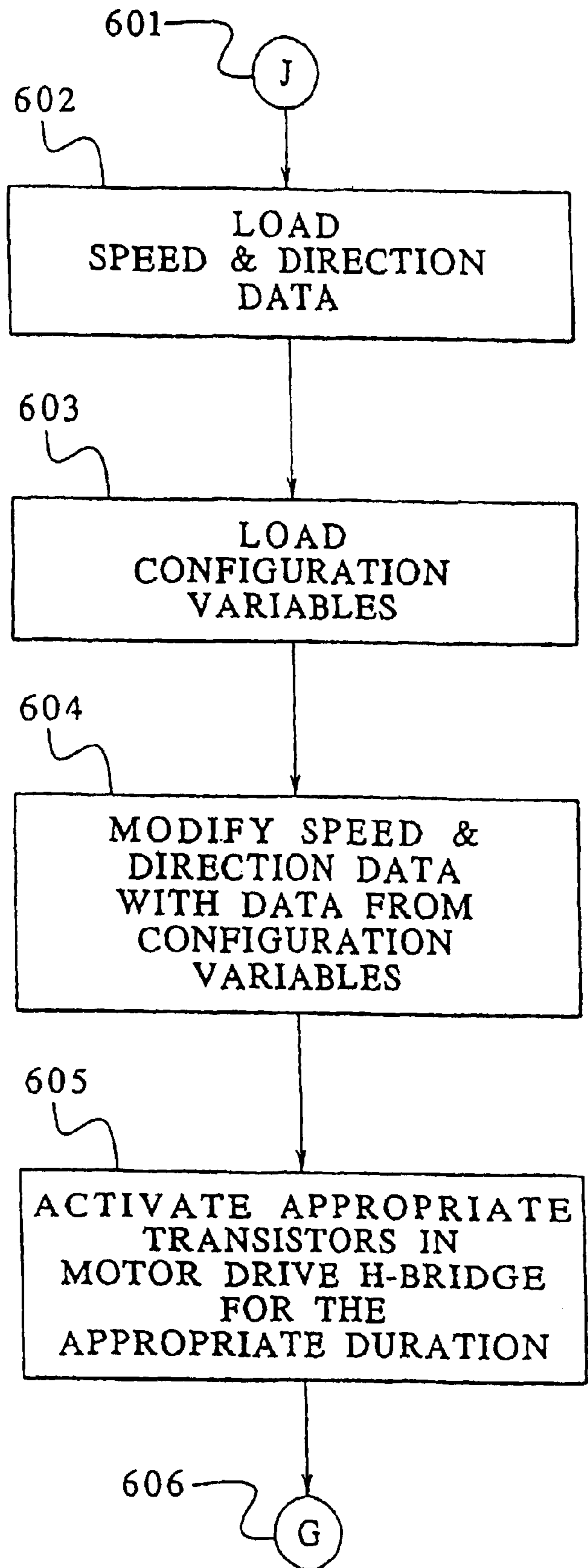

FIG. 20



**SOUND RECORDING AND REPRODUCTION
SYSTEM FOR MODEL TRAIN USING
INTEGRATED DIGITAL COMMAND
CONTROL**

Matter enclosed in heavy brackets [] appears in the original patent but forms no part of this reissue specification; matter printed in italics indicates the additions made by reissue.

RELATED APPLICATION DATA

[This application is a continuation-in-part of U.S. patent application Ser. No. 08/289,257, filed on Aug. 11, 1994, now abandoned.] *This application is a divisional application of U.S. Reissued Pat. No. U.S. RE38,660 E issued on Nov. 23, 2004 as a reissue of U.S. Pat. No. 5,855,004 issued on Dec. 29, 1998. U.S. Pat. No. 5,855,004 is a continuation-in-part of U.S. patent application Ser. No. 08/289,257, filed on Aug. 11, 1994, now abandoned.*

BACKGROUND OF THE INVENTION

The present invention generally relates to a modular device, system and method for storing, playing back and recording audio data. More specifically, the present invention relates to a modular device, system and method for reproducing audio data, such as voice and sound effects in a realistic manner.

It is, of course, generally known to generate simulated sounds in response to external stimuli, such as motion. One common industry in which sound production is often simulated is the model railroad industry. Sounds, such as those made by various animals, such as cows, sheep, pigs, and the like, are often reproduced. These sounds are typically generated in connection with a particular car of a railroad to enhance the interest and realism of the model railroad.

Another example of sounds being generated in conjunction with model trains is the heightened realism attained when used with a steam or diesel locomotive. In the past, when sound features have been controlled in conjunction with a model locomotive, methods other than motion have been used to turn these types of sound effects on and off. Some of these methods have been: DC voltage superimposed upon an AC voltage, magnets, reed switches or Hall effect sensors. The use of radio signals or a carrier control signal superimposed upon an AC or DC voltage have been used as well. Furthermore, a separate controller, which varies either AC or DC voltage or current, was required to control the speed and direction of the model train. There has not been a means to integrate all simulated controllable functions a model train may have into a model locomotive or car.

A need, therefore, exists to realistically reproduce and control sound effects, control model train motors and special effects. This need can be best filled by using a sound unit and Digital Command Control for controlling simulated sounds and simultaneously control propulsion of the model trains. Digital Command Control is a type of control that makes use of a digital bi-polar signal to control model trains. As defined in the NMRA Standards, the National Model Railroad Association baseline, Digital Command Control signal consists of a stream of transitions between two equal voltage levels that have opposite polarity. Alternate transitions are separate binary bits in a transmission stream. The remaining transitions divide each bit into a first part and last part. Use of this format gives the hobbyist the most choices for controlling aspects of a sound unit mounted in a model train as a self contained unit or in a track side structure as a accessory.

An example of a known sound effect producing model railroad car is described in U.S. Pat. No. 5,267,318 to Severson et al. The '318 patent teaches a speech synthesis circuit for playing selected cow voices stored as digital data in an EPROM. In a random mode of operation, a state generator provides a pseudo-random count that is used to select among four different cow voices, one of which is silence. The resulting audio output is perceived as random contented cow sounds. A pendulum motion detector provides an indication of lateral motion of the system. An up/down motion counter maintains a motion count reflecting the level of excitation of the system and the cows. The motion counter increments responsively to motion and decrements gradually in the absence of detected motion. A motion count of at least four invokes a triggered mode of operation in which the counter output is used to select among four different excited cow voices.

In the alternate embodiment of the present invention that uses only the sound reproduction apparatus, its improvement over the '318 patent is that no motion counter, micro-controller or state generator is needed to generate a response to a lateral movement of the sound car. The simple movement of the car is all that is needed to cause a response from the sound memory to play-back simple sound effects.

Previous inventions that have tried to control sound effects for model locomotives have only utilized an electro-mechanical means to control the synchronized sound functions whereas the present invention controls all aspects using digital control of the following: sound, model locomotive speed, direction and special effects [on board] *on-board*. Another known system that relates to model trains is U.S. Pat. No. 5,174,216 to Miller et al. In the '216 patent, there is no means to execute sound effects at the model train enthusiast's discretion or to control speed, direction or other [onboard] *on-board* special effects. The '216 patent also utilizes a single chuff sample for all speeds, that is controlled using an opto-sensor to define an on or off state. The opto-sensor simply controls one chuff sound effect no matter at what speed the model locomotive may be traveling. The speed simply determines the rate of the chuff. It cannot select from a set of speed sound effects that give a better simulation of different speeds and [work loads] *work-loads*. The present invention overcomes this deficiency by comparing the on-off rate of the sensor to the digital speed packet. Furthermore, the '216 patent makes use of a limited menu of bell, whistle or horn sound effects that are triggered through the use of a Hall effect and various [combination] *combinations* of magnets that are interpreted by a micro controller. The micro-controller then determines which bell/horn whistle sound effects to play. This system relies upon magnets placed along the model railway at specific points. The '216 patent system does not allow for any random play-back or variance of the predetermined menu of sound effects. The '216 patent relies upon a variable AC or DC voltage to control the frequency of the steam chuff or the amplitude of the diesel throb. The previously mentioned variable track voltage is also used to supply current to the sound reproduction circuitry. Because of the variable nature of the power supply for speed control, in order to hear sound effects through all voltage ranges especially in the 0 to 5 volt range, a switchable power supply is needed to change between the track supplied power and a battery back-up contained within the model train locomotive or car.

The '216 patent also is deficient in that it is not able to discretely control sound effects, or regulate the speed of a model locomotive, control direction and other onboard special effects at any random location. The '216 patent is only

able to trigger specific sound effects at predetermined locations, and a battery back-up is required for use in all voltage ranges. Because the '216 patent makes use of the variable track supplied power to supply voltage for the circuitry and regulation of the chuff or diesel sound effects, it is unable to operate at slow prototype speeds in a model setting.

There have been attempts at controlling the speed of a model locomotive, sound and special effects to overcome the above deficiencies. One known system that attempted to do this is taught in U.S. Pat. No. 4,914,431. In this patent, the motor controller device is used with AC-powered model trains where typically these types of trains make use of variable AC voltage to control the speed of a locomotive, typically described as "Lionel trains." Furthermore, these types of trains make use of a three-position switch that is controlled by a solenoid to determine forward, neutral or reverse. This unit is called a reverse unit, which the '431 patent is designed to operate exclusively. The scope of the '431 patent is intended to sync the electronic reverse units of a master and slave locomotive. Furthermore, the control system uses state generators for expansion of the remote control effects found on a model locomotive. This is accomplished by simply using a positive and or negative DC digital pulse repeatedly applied to create and to control a plurality of state control signals. Although each motor controller can operate up to sixteen states, only four state generators are enabled for use. This pulse signal is superimposed on the AC motor control supply voltage and can only control one set of special effects per usage. Another deficiency of the '431 patent is that, in its preferred embodiment, only two addresses are possible: a master and a slave. The '431 patent is not designed for multiple locomotives in use in multiple combinations. For the operator of DC powered trains, these deficiencies make the device unsuitable. Finally, this system to control motors and sound effects is a proprietary system and does not inter-operate with any control system other than those for AC-powered trains.

Another known patent that attempts to control speed, sound and special effects in more than two locomotives is U.S. Pat. No. 5,441,223 to Young. In this patent, an RF and an electro-magnetic signal are used in conjunction with a triac to control speed of AC powered locomotives. The triac is modulated and turns the AC power on and off for speed control of the addressed locomotive. This system is designed specifically for "Lionel" brand trains. Reverse compatibility is required to operate previously made AC trains that use the three position reverse unit. As in the '431 patent, the '223 patent uses a switching circuit to control the reverse unit using commands. In a further attempt to preserve reverse compatibility, the '223 patent may still superimpose upon the AC motor control current a DC offset for control of whistle and bell effects on non-receiver equipped locomotives. Due to the need to control the reverse unit and the DC offset, any other type of model trains, that require DC current for motor power cannot use this system. In addition, to the limitation of operating AC powered trains only, the quantity of locomotives the hobbyist may operate with this system is limited to ten. There are additional operational limitations to this system: it requires a hands on approach to access a switch, to place the locomotive in a programming mode, a manual switch needs to be accessed, the inability to tailor locomotive motor performance characteristics such as acceleration and/or deceleration, and *the* inability to tailor sound performance to personal preferences.

There are also three other known U.S. patents that make use of a command control structure for only motor control.

One is U.S. Pat. No. 4,572,996 to Hanschke et al. This patent makes use of a Digital Command Control format, but is limited in scope due to its limited address capabilities and the lack of hobbyist programmable features to enhance performance of the locomotives and sound systems. Like the '431 and '223 patents, it is a proprietary system that uses its own protocol. Furthermore, the '996 patent lacks the ability to operate other brands of Digital Command Control receivers which limits its usage.

U.S. Pat. No. 4,335,381 to Palmer makes use of a composite waveform, again demonstrating the proprietary nature of these types of controls. Furthermore, the data portion is a burst that is attached to the back of the waveform that actually powers the devices attached to the controller. This system, although flexible, appears to be limited in its address capabilities due to the method of selecting addresses for each receiver, and the quantity of data bits appears to affect the amount of power available to power motors and ancillary devices. Like the '996 patent, it is limited in its preferred embodiment to speed, direction and inertia.

U.S. Pat. No. 4,341,982 to Lahti et al. makes use of a carrier control signal. This patent uses DC power for propulsion of the model locomotive motor and simply superimposes a selected modulated frequency on top of the DC power. The superimposed control signal is a [band width] *band-width* equal to the highest frequency of the carrier control signal which is equal to the highest selected carrier control address. This system's deficiencies include no easy way to change a locomotive's address, limited in [band width] *band-width* for address range, operating characteristics of the motor controller are limited to: direction and deceleration only, and no provisions for additional features to be actuated remotely, such as operation of a sound unit or special lighting effects.

As seen by the above patents, prior art exists; however, each makes use of a proprietary format that only operates each manufacturer's or inventor's devices and are limited in operational characteristics. The present invention, on the contrary, operates across any manufacturer's control systems as long they observe the NMRA digital format now in practice.

The present invention overcomes the above shortcomings by utilizing a micro-controller that decodes a discreet bi-polar digital command directed to its specific address for control of: sound effects, speed regulation, direction of a model locomotive and control of on-board special effects. In addition, the constant voltage supplied to the track is able to supply a constant voltage from a regulated power source to the present invention at all times, no matter what the speed of the model locomotive. In addition to the simple features as outlined, the hobbyist also has access to certain registers that may be used to customize a model locomotive's motor control characteristics and sound features.

The previously mentioned micro-controller uses, in this embodiment, a prescribed packet format that includes speed, direction and accessory/special effects commands. The preferred digital format that is used is dictated by the National Model Railroad Association. By using this format the present invention is able to inter-operate with control systems that are currently on the market and is not dependent on a proprietary control system. However, various digital formats exist for the use of model train control, and the present invention can be adapted to these as well. All aspects of the present invention may be controlled in a "hands-off" manner by executing various addressed commands that are sent on a plurality of tracks as a digital signal to a specific model

locomotive. The only limit on this type of invention is the size of the micro-controller and sound memory.

SUMMARY OF THE INVENTION

The present invention can be executed in two configurations, the first uses only the sound reproduction apparatus. The other configuration uses the sound reproduction apparatus and a digital control decoder which is useful when used with model trains that use Digital Command Control.

In the first embodiment, the sound storage and reproduction section of the present invention is used to generate a sound with or without external stimuli, such as being used in a sound-producing, model railroad car. Moreover, the present embodiment provides a system and a method for recording audio data and playing back the audio data in an asynchronous manner. This embodiment provides a simplified means to store and play-back the audio from the sound storage chip. In the preferred embodiment of the present invention an EEPROM is used, that uses Direct Analog Storage Technology (DAST™ by Information Storage Devices) which makes an analog recording of the audio information.

In an alternate embodiment of the sound storage section, the audio is digitized and compressed, and voice synthesis is used as steps in recording the information onto a digital EPROM for use with, for example, but not limited to a Yamaha YM3812 as a sound generator. For play-back, a digital to analog conversion is necessary to convert the digitized information into an analog [wave form] *wave-form*. The preferred embodiment of the present invention uses an analog EEPROM that does not require any of these intermediate steps. So the present device simplifies the recording and playback operation for this type of application when used in the preferred embodiment.

Furthermore, by the addition of a microphone to the preferred embodiment, the consumer may add his own voice to the pre-recorded material to tailor the sound effect in some applications through the use of the DAST™ EEPROM that permits recording and re-recording of additional voice or audio effects. This additional voice information may be blocked from overwriting the pre-recorded material on the chip through the use of the multiple address capabilities the DAST™ EEPROM possesses.

When the device is executed in the second configuration using Digital Command Control, the following functions may be accessed and controlled: sound, speed, acceleration, deceleration, direction and any special effects. In a preferred embodiment, a plurality of sound effects are stored on a sound storage device at predetermined addresses that employ DAST™ technology to store an analog sound effect. These same sound effects and principles may also be utilized using a digital type of sound storage chip and a Yamaha YM3812 sound generator, as an example.

An addressed Digital Command Control signal is amplified prior to being placed on the rails to a suitable amplitude to power the sound unit's analog or digital sample memory, integral decoder, power the model locomotive's motor and special effects. Each sound unit uses a discrete address so that it may be independently controlled, and multiple sound units may be in use by the model train operators. Each model train operator controls the following functions of his particular sound unit: all sound functions, model train motor control, and [on board] *on-board* special effects.

The present invention makes use of prescribed digital control packets that are addressed to a sound unit's decoder and broadcasted through either two or three model train rails, an

overhead track wire or a buss line for reception. The present invention decodes multiple broadcasted digital packets of which one will match the sound unit's preset address. The sound unit activates an appropriate sound, light or other special effect or institutes changes upon motor speed or direction based upon the information contained within the decoded digitally broadcasted packets. The sound effects may be synchronous using the speed packets to determine a sound effect or asynchronous if a bell, whistle/horn or background sound effect is activated. A motor speed packet of zero indicates a stop condition. Any of the sound unit's decoder functions allow sound, motor control or special effects functions to be acted upon by the decoder at any random location around the model train setting and are not limited to predetermined locations. The sound effects may be, but are not limited to, the chuff sound of steam locomotives, blow down, air compressor pumps, generator, bell and whistle. The sounds which emanate from a diesel locomotive: motor throb, turbo charger, dynamic brake grid, air release, bell and horn may also be stored in the sound memory chip.

The motor control aspects of the sound decoder change the speed and direction of the model locomotive based upon information contained within the decoded digital packets. The speed resolution may be expressed as a number of steps which a model locomotive takes to achieve maximum speed from a full stop. A preferred embodiment uses a digital format prescribed by the National Model Railroad Association which currently allows for three different speed resolutions: 14, 28, and 128 speed steps. The greater the number of speed steps in a given resolution, the more precise the motor control will be. The motor control aspects of the sound decoder may act directly upon a properly decoded digital packet and then translate the information contained within the packet into an appropriate speed and direction. Alternatively, several registers of the serial EEPROM that the micro-controller can access known as "Control Variables" may be used to modify the information contained within the decoded digital packet prior to the translation into an appropriate speed, direction or for motor noise snubbing for the purpose of motor control. These registers may be fixed in firmware or programmable by the hobbyist. Some examples of these Control Variables, but not limited to, can include acceleration, deceleration, start voltages, motor response curves and motor noise snubbing. These Control Variables allow an end user to tailor a model locomotive's motor operation characteristics to personal preferences, often enhancing the operation of the device.

Certain Control Variables are also reserved for use by the sound aspects of the device. These Control Variables may be fixed in firmware or alternatively programmable by the hobbyist. These Control Variables allow an end user to tailor a model [locomotives's] *locomotive's* sound aspects to personal preferences often enhancing the operation of the device. By utilizing this particular feature, momentum effects may be replicated using steam or diesel sound effects. In addition, the volume may be adjusted remotely from the hand controller. In addition to the sound and motor control aspects, special effects may be controlled. These may be, but are not limited to, lights, different flasher beacons and smoke effects. Each of the sound unit aspects that may be controlled by the model train enthusiast are addressed by specific groups of digital packets for specific sound units. In other words, any of the sounds or types of movement which a real locomotive make are now possible in the model world. The previously mentioned sounds and control of the model locomotive's propulsion may be executed in combinations or in a

prescribed method of preference. All of the functions contained within the discretely addressed sound unit or units are accessed through a hand controller provided by a Digital Command Control manufacturer.

The first step in creating the sound effects for the present invention is to record the actual sounds of the animals, sound effects, steam or diesel locomotives. These sounds are mastered and edited for use in either configuration of the present invention. The sound effects that are used in the asynchronous sound module are then simply recorded onto the chip for recall using the enabling means of the Hall effect sensor or other types of sensors. In the Digital Command Control Configuration, the recording of the sound effects [is] are accomplished by recording all necessary sound effects from a specific type of [the] actual locomotive, whether diesel or steam. When a specific diesel locomotive's sound characteristics are recorded and paired to a matching model, the distinct sound characteristics are carried over to the model setting, giving a unique sound to each locomotive. However, steam locomotives vary in driver wheel arrangements and physical size. These two things determine their sound characteristics, so varying the steam locomotive types recorded will give each steam locomotive a distinct sound. So recording the different manufacturers' models gives the hobbyist the ability to pair the correct motor sound to its model instead of simply a generic sound as previously offered. In the Digital Command Control configuration, the recording of the sound effects are accomplished by recording all necessary sound effects from a specific type of actual locomotive for use with a model of the actual locomotive or within a given actual manufacturer's family of locomotives whether diesel or steam. These sound effects are then mastered, and their location in the sound memory is established. Their recall is then accomplished in the Digital Command Control embodiment of the present invention through the following steps using a steam locomotive as an example.

The chuff sound effects of a steam locomotive need to be synchronized with the movement of the steam locomotive's driver wheels. One method to accomplish this task is to utilize the properly decoded digital speed control packets to control a simulated chuff and exhaust sequence which corresponds to the speed of the locomotive. Rather than simply using one generic steam chuff, the chuff of the present invention uses multiple speed recordings of an actual locomotive. These recordings are used at similar speed intervals on the model locomotive so, as the speed increases, there is a change in the frequency and amplitude of the chuff. This is in contrast to the operation of previous sound units for use with model trains which simply reproduced a single chuff sample at different speeds by varying the on (chuff) and off (exhaust) rate according to the voltage applied to the track to set the speed of a model locomotive. Instead of the track voltage controlling a single chuff sample, the chuff on/off rate in the present device could use the DCC signal and the following alternate methods. The single chuff sample would change speed through the use of a variable oscillator controlled by the speed packets producing a corresponding speed sound effect. Or, using a single chuff whose rate is controlled by software stretching or reduce the amount of exhaust between chuffs as done in digital sound editing software. Using the previous two examples, there can be many deviations to the present invention using single or multiple samples to reproduce a corresponding sound effect for recall.

The samples made for the chuff sound effects may also be acquired for the locomotive's air brake pump to simulate different [work loads] *work-loads*. For example, when a

steam locomotive is at rest, there are various hissing sounds, and the air pump cycles at a slow rate. However, when the speed of the locomotive increases, the hissing sounds change to a chuff sound. As previously mentioned, the chuff sounds increase in frequency and amplitude in the present invention. As the chuff changes, the air pump cycles increase in frequency as well due to the simulated increase in steam pressure. These same digital packets which contain the information to select an appropriate locomotive sound effect based upon speed packets are also simultaneously used to select the appropriate motor speed for control of both aspects.

In addition to the chuff sounds and air pump, the steam blow down that is a result of stopping a steam locomotive may be represented. This sound effect may once again be an automatic function of the sound unit or under the control of the model train enthusiast. In the automatic mode of control, this type of sound effect is typically triggered by the absence of a properly decoded digital packet. This also can occur upon power-up, during a reset condition, or the decoder sensing a zero speed packet for a stop condition. The other use for this type of effect is to indicate that the broadcasting device is not sending the proper packets. In the case of a stop condition, the blow down effect is triggered for a fixed interval of time and then turns itself off. To activate the effect, a suitably addressed control packet is activated by the hobbyist, and the blow down effect will activate and remain on until the sound effect is switched off. The additional sound effects of the bell and whistle are manually operated by the model train enthusiast. These sound effects are operated in a similar fashion [for] as an actual locomotive, where the bell and whistle have no predetermined sequence of operation, and as long as the button for each sound effect is pressed, it will continue to play. However, the bell and whistle/horn may utilize a programmed sequence for typically used whistle/horn and bell signals. These same types of control methods used for a steam locomotive can be applied to a diesel locomotive as well. The hobbyist also has the option to mute the chuff/motor sound effects by using a function button on the hand controller. This feature, when activated, allows the model train enthusiast to still activate the bell and whistle/horn sound.

An alternate means to synchronize the speed of the chuff is to employ a mechanical, magnetic or electro-mechanical device to allow the micro-controller to sense the revolutions of the locomotive drive axles. A preferred embodiment of the alternate means to synchronize the sound effects to the speed of the model locomotive is to use a Hall effect sensor to sense the rotation of the steam locomotive's drive wheels. This may be accomplished by placing a magnetic strip on the rear of a drive wheel. When the Hall effect senses a change in the magnetic field, it prompts the playback of a chuff sound. The chuff sound effect played back is determined by two factors: the first is the change in the magnetic field to determine the rate of play back, and the other factor is the digital speed packet determining the proper speed sound effect played back from the samples of the different speeds recorded and contained within the analog or digital sound memory.

To this end, in an embodiment, a system is provided for playing back pre-recorded audio and for recording additional sounds by the hobbyist and playing back all recorded sounds. The system has a power source and a sound module means having at least one characteristic sound recorded thereon and operatively connected to the power source. An asynchronous enabling means activates the playback of the at least one characteristic sound from the sound module means. The enabling means actuates the playback upon

occurrence of a condition thereby providing a signal to the sound module means.

In an embodiment, the enabling means is a Hall-effect sensor responding to a change in a magnetic field. Further, the system [further] has a magnet and a pendulum on which the magnet is suspended wherein motion causes the magnet to transpose resulting in the change in the magnetic field.

In an embodiment, the system further has an expanded memory operatively connected to the sound module means.

In an embodiment, the system further has a microphone constructed and arranged for the hobbyist to record the at least one additional characteristic sound directly to the sound module means by the hobbyist.

In another embodiment of the present invention, a model railroad car system is provided including a plurality of cars, at least one of the plurality of cars capable of producing simulated sounds. The system has a power source providing power to the plurality of cars and means for producing sound connected to the power source. The means for producing sound is capable of recording and playing back sounds. An asynchronous activation means is constructed and arranged to provide an enable signal to the means for producing sound resulting in playing back one of the sounds.

In an embodiment, the activation means of the model railroad car system is a magnetically responsive sensor constructed and arranged near a magnetic field wherein the magnetic field may be altered by a magnet.

In an embodiment, the method further has the steps of providing a magnetic source; creating a magnetic field; and providing a magnetic responsive sensing means responsive to changes in the magnetic field to thereby generate the signal.

Another application for the alternate embodiment is a sound reproducing device wherein a microphone may be connected to a consumer device for the home, such as a doorbell or audio-type message pad.

It is, therefore, an advantage of the present invention to create a modular sound recall and play back circuit to adapt to a variety of applications for producing sound.

Still further, an advantage of the present invention is to provide a system and a method to internally activate audio in the first embodiment without the need to externally trigger the at least one sound.

And, another advantage of the present invention is to provide a system and a method to trigger or activate the sound module using the same circuit design.

Another advantage of the present invention is it will decode multiple broadcasted digital packets of which one will match the sound units preset address.

Another advantage of the present invention is that it may see one match for the sound unit's preset address and may activate an appropriate sound, light or other special effect or institute changes upon motor speed or direction based upon the information contained within the digitally addressed and decoded broadcasted packets.

Another advantage is that each model train operator has independent control of the following functions of their particular sound unit: all sound functions, model train motor control, and on-board special effects.

A further advantage is the sound effects may be synchronous using the speed packets to determine a speed sound effect or asynchronous if a bell, whistle/horn or background sound effect is activated for the decoded digital packet.

Another advantage of the present invention is the use of multiple sound samples to emulate the change in speed and [work load] *work-load*.

Another advantage is automatic modes of control for specific sound effects.

Another advantage of the present invention is any of the sound unit's decoder functions, i.e. sound, motor control or special effects functions, may be acted upon by the decoder at any random location around the model train setting and are not limited to predetermined locations.

Another advantage of the invention is the motor control and sound aspects of the sound decoder may be simultaneously acted upon directly when a properly decoded digital packet is translated for the information contained within the packet into an appropriate speed and direction.

Another advantage is the hobbyist has registers in a EEPROM that the micro-controller can access known as "Control Variables" that may be used to modify the information contained within the decoded digital packet to tailor operation to their tastes in the areas of speed, direction, motor noise snubbing and sound functions.

Another advantage is the choice between a menu of whistle/horn or interactive play-back of these types of sound effects.

Another advantage of the present invention is the ability to digitally synchronize sound effects and the speed of the locomotive.

Another advantage of the present invention is to remotely mute or adjust the volume to suit personal preferences.

A further advantage of the present invention is its ability to operate with different Digital Command Control systems that make use of the NMRA packet format.

These and other advantages of the present invention are described in, and will be apparent from, the detailed description of the presently preferred embodiments and from the drawings.

BRIEF DESCRIPTION OF THE DRAWINGS

FIG. 1 illustrates a side view of a model railroad car embodying the components required for reproducing sounds with the principles of the first embodiment of the present invention.

FIG. 2 illustrates a top plan view of an embodiment of the components mounted on a circuit board creating a base of a model railroad car, the components embodying the principles of the present invention for reproducing simulated sounds.

FIG. 3 illustrates a side view of an embodiment of a magnet supported by a pendulum over a sensor for the present invention.

FIG. 4 illustrates a block diagram of an embodiment of the components necessary for implementing the system and method of the present invention.

FIGS. 5A-5C illustrates a circuit diagram of an embodiment of a portion of the components for generating sounds in response to an enable signal for the system and the method of the present invention.

FIG. 6 illustrates a circuit diagram of an embodiment of recording circuitry for the present invention.

FIGS. 7A-7C illustrates in schematic diagram form of the components contained on the first of two printed circuit boards in the original configuration.

FIGS. 8A-8C illustrates, in schematic diagram form, the components contained on the second of two printed circuit boards in the original configuration.

FIGS. 9A-9C illustrates in, schematic diagram form, the components contained on the second of two printed circuit boards in an alternate configuration.

11

FIG. 10 illustrates a graphical representation of a Digital Command Control (DCC) baseline packet.

FIGS. 11–20 illustrate, in flow chart form, the operation of the micro-controller software.

DETAILED DESCRIPTION OF THE PRESENTLY
PREFERRED EMBODIMENTS

Referring now to the drawings for an embodiment of the present invention, FIGS. 1 and 2 illustrate assembly views of a model railroad car encompassing one embodiment of the present invention. As illustrated in FIG. 1, an exemplary model train car 1 is shown. The model train car 1 includes a platform or base 10 operatively connected to a plurality of wheels 12 as is generally known. The base 10 includes a printed circuit (PC) board for connection of electrical components thereon. Although not illustrated, the electrical components hereinafter described are typically enclosed within a housing such that the model train car 1 encloses the components and provides a decorative appearance in its ordinary usage.

The base 10 includes a PC board for electrical connection of components thereon. One of these components is an analog sound storage processing chip 14 manufactured by, for example, Information Storage Devices (ISD). The processing chip 14 is provided with DAST™ analog memory for storage following recording of various sounds recorded thereon or for subsequent reproduction of the recorded sounds. Connected to the processing chip 14 is an audio amplifier 16 and a sensor 18, such as a Hall-effect sensor as illustrated in FIGS. 1 and 2 having a northern polarity. Of course, other sensors or activators may be implemented. The DAST™ analog storage chip 14 also includes an internal microphone amplifier 38 (FIG. 4) external to or built into the chip 14. The microphone 38 enables recording of additional desired sounds on the chip 14.

An integral part of the sensor 18 includes a non-conductive and non-magnetic pendulum 24 and a magnet 26 suspended above the Hall-effect sensor 18 by a hanger 25. A battery 28, such as a standard nine volt battery, is provided as power for the system. An on-off switch 30 is further provided to activate the system. A regulator 32 is provided to provide five volts of power from the nine volt battery source. Further, a potentiometer 34 is provided to regulate the volume level.

The details of the sensor 18 are more clearly illustrated with reference to FIG. 3. As illustrated in FIG. 3, the sensor 18 includes the hanger 25 supporting the pendulum 24 which swings freely on the hanger 25 with a magnet 26 at the distal end of the pendulum 24 opposite the connection of the hanger 25 to the pendulum 24. The pendulum 24 and the hanger 25 are, in a preferred embodiment, a non-magnetic, non-conducting wire armature. The hanger 25 is mounted to the PC board 10 as illustrated. The magnet 26 swings freely above the Hall-effect sensor 18.

The Hall-effect sensor 18 is operable to produce an enable signal when the object, such as the model train car 1, begins to move. When the movement ceases, the switch remains open until a forward action or a reverse action takes place. The polarity of the magnet 26 and the Hall-effect sensor 18 must match to induce a closure of the switch. That is, the Hall-effect sensor 18 and the magnet 26 must be in alignment. In addition, since the wire armature is constructed of a non-magnetic material, the suspended magnet 26 remains centered above the Hall-effect sensor 18. Therefore, movement in the system creates a disturbance between the Hall-effect sensor 18 and the suspended magnet 26 on the pendu-

12

lum 24 resulting in production of the enable signal sent to the processing chip 14 to play back the sound recorded thereon.

FIG. 4 illustrates a diagram of the components in black box format and in schematic diagrams in FIGS. 5 and 6.

Referring to FIG. 4, the power source 28 is activated either on or off by the switch 30. When power is provided to the system, the voltage regulator 32 limits the voltage to the analog processing chip 14 to five volts. The sound module DAST™ analog processing chip 14 is activated by the sensor 18 as previously discussed. The sensor 18 may be a Hall-effect sensor 18.

When any of the sensors or switches are activated, the sound module DAST™ analog chip 14 produces an output which is amplified through the audio amplifier 16 and subsequently passed through the compander 20 and finally to the speaker 22 as an audio output. The sound module analog storage chip 14 further includes internal memory for storing of particular sounds that may be supplemented with additional memory as illustrated at 36 in FIG. 4. The additional memory 36 allows for additional sounds and greater lengths of time for recording sounds on the sound module analog processing chip 14. An external microphone input 38 may be connected as an input for recording of sounds on the chip 14. Alternatively, the DAST™ chip 14 is provided with a built-in microphone for recording of sounds thereon.

The present invention will be described with reference to a livestock sound module used with a model railroad car which plays pre-recorded messages when activated, although it should be understood that any environment requiring playback of sound may implement the sound reproducing and recording system of the present invention. Up to six basic components or sections may be implemented to perform the features embodied by the principles of the present invention.

The first section is the power supply previously described. The power supply when used with a model railroad car may run off of track voltage wherein the power is input to a full-wave bridge rectifier and a capacitor acting as a filter. The output is then connected to a voltage regulator. The nine volt DC input from, for example, a nine volt DC battery, is tied in at a node through a diode. If a nine volt battery is used in conjunction with the track power, the battery acts as a low voltage backup keeping the module voltage up when the track voltage drops off or shuts off. Power is switched to the module via the SPST switch.

The second section of the present invention is the DAST™ analog sound effects chip and audio expander. The DAST™ analog sound effects chip is capable of storing between twelve seconds and 120 seconds of analog data in a non-volatile analog memory. Various audio messages can be programmed into the sound effects chip. The library messages are stored on, in a preferred embodiment, a digital [audio tape] audiotape. When the messages are programmed, the analog audio signal is played back at a pre-recorded level and sent through a compressor. A compander is used in the present invention which reduces the dynamic range of the signal before it is recorded into the chip. When the sound effects are played back from the chip, they are played back through an audio expander. The expansion does two things: the audio is expanded and the signal is restored to its original dynamic range; and when the audio is expanded, low-level audio noise in the system is attenuated giving an improved signal-to-noise ratio.

The third section of the circuit is the audio amplifier. In a preferred embodiment, the amplifier is an LM386N-1. The

13

output of the audio amplifier is capacitively coupled to a volume potentiometer. The wiper of the potentiometer is the input of the amplifier. The output of the amplifier is capacitively coupled and connected to a speaker.

The fourth section of the circuit is the message activation or chip enabling section of the circuit. Pin 23 of the sound effects chip is the chip enable. Chip enable is an active low signal, and the pin is pulled high with a resistor and a decoupling capacitor in parallel. The configuration of the device initiates the message inside the chip to be played by pulling of the pin to ground. The message plays once unless the pin is held low. If held low, the message continues to repeat until the pin is allowed to get pulled to high.

The pin can be activated several ways as previously set forth. A Hall-effect sensor below a suspended magnet may be implemented in a preferred embodiment. When a train car travels along or is jarred on a track, the change in the magnetic field from the magnet swaying causes the Hall-effect sensor to activate and give a momentary pull to ground thereby initiating the chip. Therefore, the present invention is activated by inertia-sensitive control.

The fifth section of the present invention is the option of recording custom messages. The chip has a built-in microphone amplifier that can be used to record audio data. This is controlled by the state of the playback/record pin. When held low, the chip is then put into record mode and will record audio as long as the chip enable is held low. Alternatively, an external microphone may be implemented for recording on the chip.

Referring to FIG. 6, two microphone inputs to the ISD device, MIC (pin 17) and MIC REF (pin 18) are illustrated. The two pins are differential inputs to an on-chip microphone preamplifier. A non-biased microphone can be connected directly across the two inputs. A 470 kOhm resistor, connected parallel to a 4.7 MF capacitor is placed across the automatic gain control AGC input (pin 19). These two components set up the attack and release time constant for the internal AGC circuit inside the chip. The AGC circuit controls the gain of the microphone preamplifier built inside the chip.

To record a new message on the chip, two pins on the chip are controlled, /Chip Enable and Playback/Record. /Chip Enable controls the start of both the record and play cycles. The level of the Playback/Record pin will determine whether a new message is to be recorded or the saved message played back. Pin 27 (P/R) is normally held high and messages play back as long as chip enable (/CE pin 23) is held low. If P/R is pulled to ground and then /CE is pulled low, the chip is then automatically placed into record mode and records the analog signals in real time picked up by the microphone. Recording stops when /CE is brought high. As previously mentioned, by controlling the address or logic level, the location of the new message can be controlled such that it will not record over previous audio.

Due to the limited space available within model train locomotives and cars, the present configuration uses two narrow elongated printed circuit boards (PCB's) stacked upon each other on which the electronic components are mounted in this embodiment. The circuit boards are electrically interconnected by means of a multi-pin plug on the upper PCB and a mating socket on the lower PCB.

FIG. 7 illustrates in schematic form the components mounted on the upper PCB. The micro-controller, IC1 section 101 contains and executes the software program required for this invention. The present configuration of this invention uses a Part No. Z86E08-08PSC from Zilog, Inc.,

14

Campbell Calif., IC1 Section 101. The other components mounted on the upper PCB are the micro-controller oscillator section 102, IC2 section 103, a Part No. 93C56A serial electronically erasable read only memory from National Semiconductor, Inc., Santa Clara, Calif.; the function #0 and #1 output transistors and connector section 106; the motor drive transistors and filter network section 107; the DCC digital input signal conditioning components section 108; the power supply section 109; the electrical plug to the lower PCB section 110; a shift register section 111; and a Hall effect sensor section 112.

FIGS. 8A-8C illustrates in schematic form the components mounted on the lower PCB in the present configuration. The direct analog storage DAST™, integrated circuit, IC5, and associated decoupling capacitors section 201. The present configuration of this invention uses a Part No. ISD1020A for IC5 from Information Storage Devices, Inc., San Jose, Calif. The other components mounted on the lower PCB are the mating socket to the upper PCB section 203; an audio computer circuit section 204; an audio amplifier circuit with volume control section 205; and a Power Down/Reset Circuit section 206.

Referring now to FIGS. 7A-7C, operation of the upper PCB of the present invention will be described. A bi-polar digital signal of sufficient voltage and current is attached to J2 section 109 and the jumpers on J4 section 108 and J5 section 108 are placed between pins 2 and 3 on each. In this configuration, the power source is also the digital signal; a common example being "DCC", a protocol of the National Model Railroad Association (NMRA). This is the configuration used when the present invention is installed in a model railroad locomotive or car as J2 section 109 may be wired to the track using mechanical electrical pickups on the wheels.

An alternate configuration uses a separate power source between 14 to 24 volts AC or DC which is connected to J2 section 109 on the upper PCB, and the jumpers set on J4 section 108 and J5 section 108 are placed between pins 1 and 2 on each while a bi-polar digital signal is attached to J3 section 108.

In either configuration, the unregulated AC, DC, or bi-polar DC power source passes through fuses F1 and F2 section 109. These fuses protect both legs of the power source and, to some degree, protect from shorts, overloads, or other faults involving the present invention or associated field wiring. The power source is then passed through a bridge rectifier (BR1) section 109 to two voltage regulators, VR1 (MC7812CT) 109 and VR2 (MC7805CT) section 109 to associated filter and decoupling capacitors. A heat sink is attached to VR1 and VR2 section 109.

The result is three power supply potentials consisting of a "V+" unregulated output for sourcing the special effects outputs and motor control. [a] A regulated "+12 vdc" powers the audio amplifier circuitry, and a regulated "+5 vdc" to power the logic circuitry.

The digital signal whether input through J3 section 108 or J2 section 109 is half-wave rectified by D1 section 108, current limited by R3 108, and is annunciated by LED 1 section 108. It then enters a Schmitt trigger [opto1] opto-isolator, [(OPTO)] (OPTOI) section 108. The opto-isolator provides a safety layer of isolation between the signals input and field wiring in the model setting. The Schmitt trigger aspect protects from data errors due to [low level] low-level digital noise. The digital signal exits the opto-isolator in an inverted state and enters a micro-controller (IC1) through the Input No. 2 line section 101.

The micro-controller's speed is set by a Crystal (XTAL 1) section 102 and an [on board] *on-board* oscillator.

There are several output lines associated with the micro-controller section 101. Two of the lines, output 10 and output 9, are connected to the gates of driver MOSFET transistors, Q1 and Q2 section 106, which are open drain, active low auxiliary outputs; function No. 0 and function No. 1 (F0 and F1) section 106. The transistors have current limiting resistors R1 and R2 section 106 connected to the drain-source path, in series with the load. The current limiting resistors' values are selected according to the load(s). In a typical model railroading application, Q1 is connected to a flashing LED beacon or similar device and is controlled as F1. Q2 is connected to the locomotive headlight and is controlled as F0. The use of F0 as head lamp control is based upon the NMRA DCC standard; however the function outputs can be re-configured for different loads and control assignments.

Output lines 1-4 section 105 are connected to the gates of driver MOSFET transistors, Q3-Q6 arranged in an H-bridge configuration section 107 for pulse width modulated bi-directional control of a DC motor. A controllable filter network is connected across the DC motor for the modification of motor drive wave shapes for the suppression of undesirable audible noise section 107.

Output lines 5-8 section 104 are connected to the serial EEPROM section 103 and a shift register section 111. The serial EEPROM contains many memory registers which contain information that is used to define various operating characteristics of the invention. Most of these registers are defined by the NMRA and are termed Configuration Variables (CV or CV's). Some of the registers are set aside for application specific uses defined by the manufacturer. Most of the CV's can be altered by the hobbyist through programming. The digital address of the sound effect to be played is loaded by the micro-controller into the shift register section 111.

Output line 11 and input line 3 on the micro-controller section 101 are connected to the multi-pin plug section 110 which routes signals to the lower PCB.

Now refer to FIG. 8 to understand the operation of the lower PCB of the present invention.

The DAST™ chip (sound effect chip), IC5 section 201 is the first section of the circuit component on the lower PCB. The DAST™ chip is capable of storing between twelve seconds and 120 seconds of analog data in a non-volatile memory. Various audio sound effects can be programmed into the DAST™ chip. The location of the various sound effects in the DAST™ chip are assigned by setting the appropriate bits on the DAST™ chip's address inputs. At the time of recording, these address locations may be set by some type of development system. During playback, the address locations are set by the micro-controller IC1 section 101.

When the sound effects are played back from the chip as set by the microcontroller IC1 section 101, they are played back through an audio compander section 204. The expansion does two things: the audio is expanded and the signal is restored to its original dynamic range; and when the audio is expanded, low-level audio noise in the system is attenuated giving an improved signal-to-noise ratio.

The third section of the circuit is the audio amplifier. In a preferred embodiment, the amplifier is an LM386N (IC4) section 205. The output of the audio expander is capacitively coupled to a volume potentiometer. The wiper of the potentiometer is the input of the amplifier. The output of the amplifier is capacitively coupled and connected to a potentiometer.

The fourth section of the circuit is the sound effect activation or chip enabling section of the circuit. One pin of the DAST™ integrated circuit (IC5) section 201 is the chip enable. Chip enable (/ce) is an active low signal, and the pin is pulled high with a resistor. Chip enable is connected with output line 11 on the micro-controller. Sound effect playback is initiated by loading the appropriate address bits into the shift register section 111 on the upper PCB and then bringing chip enable low. Typically, for playback of a single sound effect, /ce is brought high after sound effect playback begins. If playback of consecutive sound effects is desired, /ce is left low. At the end of each sound effect, a signal is generated on another pin of the DAST™ chip (IC5) called End of Message (/com) (active low). /com is connected to input line No. 3 of the micro-controller section 101 through socket J7 section 203 and J1 section 110. If it is desired to repeat a sound effect, either with spaced repetition or with seamless looping, /eom is monitored to mark the end of the current sound effect being played allowing the micro-controller to precisely control repetition or looping.

PNP transistors Q3 and Q4 section 206 have their bases connected to A6 and A7, respectively, and their collectors are tied to ground. The open emitters of Q3 and Q4 are connected to a pin of the DAST™ chip (IC5) section 201 which is labeled Power Down, an active high input. Power Down is connected to a pull up resistor (R14) section 206 and a decoupling capacitor (C18) section 206. When A6 and A7 are both high, Power Down goes high and the DAST™ chip (IC5) is taken into a standby state and reset. This is useful if the DAST™ chip (IC5) should ever become errant in operation or if it is desirable to interrupt a sound effect being played before it has reached completion.

Now refer to FIGS. 9A-9C in order to understand the operation of the lower PCB of the present invention in an alternate configuration, to play back multiple sounds without using additional DAST™ memories for sound on sound.

A digital synthesizer integrated circuit IC6 in section 301 is now used for the production of sound effects. The present invention uses a Part No. YM3812 sound generator from Yamaha Systems Technology; San Jose, Calif. for IC6 section 301. Sound effects are created by alternately loading address and data information into lines D1-D8 on IC6 section 301. The alternating action is controlled by a flip-flop section 306. A digital to analog converter (DAC) section 304 is used to change the digital outputs of IC6 section 301 into varying voltages, which are the sounds. In the present invention, a Part No. YM3014 from Yamaha Systems Technology, San Jose, Calif. is used for the DAC. The output of the DAC feeds into a unity gain buffer section 305. The output of the buffer feeds into a low pass filter section 307 before reaching the volume control potentiometer R11 which is part of the audio amplifier circuit section 305. In the present configuration, the amplifier is an LM386N (IC4) section 305 from National Semiconductor, Inc., Santa Clara, Calif. The wiper of the potentiometer is in input of the amplifier. The output of the amplifier is capacitively coupled and connected to a speaker.

Now a detailed explanation of the software operation will be given. Refer now, additionally, to FIGS. 11-20.

Beginning at <START> section 501, the micro-controller section 101 is initialized in section 502. The appropriate lines are configured as either input or output. Initial values are loaded into specified registers of the micro-controller section 101. One important value is the address which is loaded section 503 from the serial EEPROM section 103. The address determines which data transmissions are

intended for the device to act upon. Input line No. 2 on the micro-controller section 101 then begins to receive transmitted data from the components in section 108. The present invention is configured to accept data transmissions based upon a digital protocol "Digital Command Control" DCC; a standard established and maintained by the National Model Railroad Association, Chattanooga, Tenn.

Refer now additionally to FIG. 10 to understand the form of the digital data transmissions. DCC data consists of bi-polar transmissions of square wave pulses each containing two equal parts: one positive and one negative. The width or duration of the pulse determines if it will be interpreted as a digital "0" bit or a digital "1" bit. A digital "1" bit in a DCC transmission has a nominal duration of 58 microseconds for each of its two parts, section 402. A digital "0" bit in a DCC transmission will have a nominal duration of 100 microseconds for each of its two parts, section 403. A complete DCC transmission can contain a varied number of bytes and is termed a packet. The one chosen for example here is a DCC baseline packet section 401. A baseline packet contains four separate components, which are the preamble section 404, the address byte section 406, the instruction data byte section 408, and the error byte section 410.

Refer alternately to FIGS. 10 and 11 wherein section 504 of the software looks at the preamble part section 404 of the DCC transmission. It is distinguished as a minimum of 10 "1" bits followed by a "0" bit section 405. Once reception of the preamble is completed, the software will begin to receive the rest of the bytes in section 505. Next is the address byte section 406 which contains eight bits which can have a value of either "1" or "0" and is terminated by a digital "0" bit section 407. Next comes the instruction byte section 408 which also contains eight bits and is terminated by a "0" bit as well as section 409. The last byte in a baseline packet is the error byte section 410 which contains eight bits and is terminated by a "1" bit section 411. The "1" bit also signifies the termination of the packet.

Once a complete packet is received, the software then checks the validity of the data by performing an error check in section 506. The error check requires that the Exclusive-Or logical function be performed upon the address byte and the data byte. If the result of this operation matches the value of the error byte, the packet is valid. If the packet is rejected as invalid, the software loops back to section 504 to await the next preamble.

If the data is deemed valid, it is first checked in section 507 to see if this was a baseline idle packet. Idle packets are part of the DCC standard and are often used for time delays. If an idle packet is detected, the software loops back to section 504 to begin receiving the next preamble, as no further action is required.

If the packet was found not to be an idle packet, several tests are performed to determine what action is to be taken based upon the data. In each case, a failed test causes a branch to the next test.

Beginning with test section 508, if it is determined, this data is intended for any and all devices receiving the data; or as termed by the DCC standard, a broadcast command. If it is, a branch is taken at section 515. At the completion of the branch, the software is at section 521 of FIG. 12. The broadcast command data is tested to see if an emergency stop command has been issued at section 522. If an emergency stop command is detected, the appropriate actions are taken to [effect] affect an emergency stop of the model train locomotive section 523. The software then branches at section 524 back to FIG. 11 at section 514 to begin receiving a new

preamble. If the broadcast command is not an emergency stop command, it is then tested to see if the present invention should be reset at section 525, termed a decoder reset by the DCC standard. If a decoder reset command has been received, the decoder is reset in section 526. The software then branches at section 527 back to FIG. 11 at section 514 to begin receiving a new preamble. If the broadcast command is not a decoder reset command, then it may be a future command which may be handled in section 528 with the appropriate action being taken. The software then branches at section 529 back to FIG. 11 at section 514 to begin receiving a new preamble.

Referring now to FIG. 11 at section 509, if the received data is not a broadcast command, it tests to see if it is a utility instruction for the decoder or consists of an instruction for the grouping of model train locomotives. If it is, a branch is taken at section 516 to FIG. 13 at section 530. The data is tested in section 531 if a decoder instruction is intended. If it is, the specific decoder instruction is executed in FIG. 13 at section 532. The software is then branched at section 533 back to FIG. 11 at section 514 to begin receiving a new preamble. If the data is not a decoder instruction (FIG. 13, section [534] 531), it may be a consist instruction. If it is, several possible actions can be taken in FIG. 13 at section 535 to allow two or more model train locomotives to be grouped together and function in actual operation as one. Once the consist instruction has been completed, or if the data does not contain a consist instruction, a branch is taken at section 536 or section 537 back to FIG. 11 at section 514 to begin receiving a new preamble.

Now referring to FIG. 11 at section 510, if the received data is not a decoder or consist instruction, it is tested to see if it contains advanced operations information. If it does, a branch is taken at section 517 to FIG. 14 at section 538. In section 539, the address information contained within the received data is compared to the pre-programmed address of the present invention. If the addresses do not match, it would be known that the information was intended for some other device. The software then branches at section 540 back to FIG. 11 at section 514 to begin receiving a new preamble. If the addresses match, it is known that the information contained within the advanced operations packet is intended for this device. Advanced operations is the means by which the DCC transmits speed data and direction when 128 step speed resolution is in place. Speed resolution may be explained as the maximum speed divided by the number of speed steps. If a model train locomotive has a maximum scale speed of 64 MPH and 128 step speed resolution is in place, each speed step is equal to a 1/2 MPH increment. This is considered fine resolution. The speed and direction information is extracted from the data in sections 541 and 542, respectively. There are several sound effects to cover the operational speed range of a model train locomotive, whether steam or diesel type. This allows the sounds generated to closely correlate with the speed at which a model train locomotive is traveling for realistic operation. In some cases, there may not be sufficient sound effects to provide for a 1-to-1 ratio between speed steps and sound effects. The end user is then able to program certain configuration variable memory registers defined by the manufacturer and contained within the serial EEPROM FIGS. 7A-7C at section 103. These configuration variables then determine when a change is made from one sound effect to another over the span of a given speed step resolution. These change divisions are termed break points and are set based upon 128 speed step resolutions in section 543 of FIG. 14. The software then branches to section 544 of FIG. 14 to FIG. 19 at section 578. Further detail is offered later on FIG. 19.

Moving back to FIG. 11 at section 511, if the received data does not contain advanced operations information, it is tested to see if it is a baseline packet. If it is, the software branches at section 518 to FIG. 16 at section 550. In section 551, the address information contained within the received data is compared to the pre-programmed address of the present invention. If the addresses do not match, it is then known that the information was intended for some other device. The software then branches to section 522 back to FIG. 11 at section 514 to begin receiving a new preamble. If the addresses match, it is known that the information contained within the baseline packet is intended for this device. The baseline speed and direction information is extracted from the data in sections 553 and 554, respectively. The baseline packet can contain speed information in either 28 step medium or a 14 step coarse resolution. A configuration variable is checked to see which resolution is currently being used in section 555. If it is determined that a 28 speed step resolution is in effect at section 556, then the break points are set based upon 28 speed step resolution and the configuration variables reserved for break points at section 559. If it is determined that 14 speed step resolution is in effect, baseline [head lamp] *headlamp* data is extracted at section 557. Then, the break points are set based upon a 14 speed step resolution, and the configuration variables are reserved for break points at section 558. After the break points are set for either 14 or 28 speed steps, the software then branches at section 560 to FIG. 19 at section 578. Further detail will be offered later on FIG. 19.

Referring now back to FIG. 11 at section 512, if the received data is not baseline packet, it is tested to see if it is a Function Group #1 Packet. If it is, the software branches at section 519 to FIG. 17 at section 561. In section 562, the address information contained within the received data is compared to the pre-programmed address of the present invention. If the addresses do not match, it would be known that the information was intended for some other device. The software then branches at section 563 back to FIG. 11 at section 514 to begin receiving a new preamble. If the addresses match, it is known that the information contained within the function Group #1 is intended for this device. The function Group #1 F0-F4 data is extracted in section 564. The data is then tested in section 565 to see if function #1 should be on or if it should be off. If function #1 should be on, it is turned on in section 567. If function #1 should be off, it is turned off in section 566. Referring now to FIG. 7, when function #1 should be on, output line #10 on the micro-controller section 101 is brought to a digital "1" state. Output line #10 is connected to the gate of MOSFET transistor Q1 in section 106. If an external device is connected across pins 3 and 4 of J6, current flows through the external device, current limiting resistor R1, and MOSFET transistor Q1; hence, the device is on. When function #1 should be off, output line #10 on the micro-controller section 101 is brought to a digital "0" state. Current ceases flowing through the external device, current limiting resistor R1, and MOSFET transistor Q1; hence, the device is off. Q1, R1, and J6 are in section 106.

Referring back to FIG. 17, the next aspect of software deals with function #0. Function #0 is typically used to control a model train locomotive headlight. A configuration variable is checked to see if baseline operation is in effect in section 568. If it is, the previously extracted baseline [head lamp] *headlamp* data at 557 is used at section 569 to determine at section 570 if function #0 should be [On] *on* at section 571 or off at section 572. Referring now to FIG. 7, when function #0 should be on output line #9 on the micro-

controller section 101 is brought to a digital "1" state. Output line #9 is connected to the gate of MOSFET transistor Q2 in section 106. If an external device is connected across pins 1 and 2 of J6, current flows through the external device, current limiting resistor R2, and MOSFET transistor Q2; hence, the device is on. When function #0 should be off, output line #9 on the micro-controller section 101 is brought to a digital "0" state. Current ceases flowing through the external device, current limiting resistor R2, and MOSFET transistor Q2; hence, the device is off. Q2, R2, and J6 are in section 106. Referring back to FIG. 17, after the state of function #0 is set in sections 568-576, the software then branches at section 577 to FIG. 19 at section 578.

Referring now to FIG. 19, at this point all of the data required to select a model train locomotive sound effect should have been received and processed. In section 579, an appropriate engine sound or other sound effect is loaded based upon the previously set breakpoints and received speed. In the case of a model train diesel locomotive, it is appropriate to imply that if a slow speed has been received, then an engine sound effect of a diesel generator at slow rpm's is selected. Conversely, if a fast speed has been received, an engine sound effect of a diesel generator at high rpm's is selected. If the present invention is used with a model train steam locomotive, varying speed discrete chuff sound effects are selected. If a model train diesel locomotive is stopped, an ultra-low RPM idle sound effect is selected. If a model train steam locomotive is stopped, a gentle hissing sound is selected. If, at this point, all of the data required to select a model train locomotive sound effect has not been received and processed, a default sound effect is selected. In the case of a model train diesel locomotive, an air release sound effect is selected. In the case of a model train steam locomotive, a steam release sound effect is selected.

Once an engine speed sound effect has been selected, it is compared with the previously selected engine speed sound effect section 580. If the most recently selected sound effect is a higher and faster sound effect, a transitional acceleration sound effect is selected first at section 581. The status of function #4 mute, from the previously received function group #1 is now checked at 582. If function #4 is active, the selected engine speed or acceleration sound effect is loaded at 583. If function #4 mute is inactive, the software continues without loading an engine speed or acceleration sound effect. Whether or not a speed or acceleration sound effect is loaded, the software continues forward to see if higher priority sound effects should be played. Next, function #3 from function group #1 is now checked at section 584. If function #3 is active, the bell sound effect is loaded at section 585. If function #3 is inactive, the software will continue without loading the bell sound effect. Next, function #2 from function group #1 is now checked at section 586. If function #2 is active, a further test is conducted to see if this is the first time function #2 has been found to be active at section 587. If this is the first time function #2 is found to be active, the first horn or whistle sound effect is loaded for model train diesel or steam locomotives, respectively, at section 589. If the second time function #2 is found to be active, the second horn or whistle sound effect is loaded for model train diesel or steam locomotives, respectively, at section 588. Through concatenation, the model train enthusiast can create realistic horn and whistle cadences. A test is now performed to see if a steam engine speed effect has been loaded at section 590. If it is not, the last loaded sound effect is now played at section 592. If no sound effects have been loaded, no sound effects are played. This would indicate that functions #2, #3, and #4 are inactive thereby preventing the loading of the

horn, whistle, bell, and engine speed sound effects, respectively. If the loaded sound effect is found to be a steam engine speed sound effect in section 590, a further test is performed to see if a Hall-effect wheel sync device in FIGS. 7A–7C at section 112 is in place at section 591. If it is not, the steam engine speed sound effect is played at section 592. If a sync device is in place, the steam engine speed sound effect is played upon the receipt of a sync pulse. If, however, more than one function is active and loaded for play-back, then more than one sound effect generating integrated circuit can be used in order to play multiple sounds at one time. After playing any loaded sound effect or effects, the software then branches to section 594.

Referring now to FIG. 20 at section 601 where the control of the model train locomotive motor begins, model train locomotives typically contain a multi-pole, permanent magnet, low-voltage motor. In the case of the present invention, pulse width modulation is used to vary the speed and direction of the motor. The previously received speed and direction data is now loaded at section 602. There are several configuration variables which can influence motor characteristics. Some examples of these control variables, but not limited to, can include acceleration, deceleration, start voltages, motor response curves and noise snubbing. These control variables allow an end user to tailor a model locomotive's motor operation characteristics to personal preferences often enhancing the operation of the device. These configuration variables are loaded at section 603. The loaded speed and direction data are now modified with data from the configuration variables at section 604.

Referring now to FIGS. 7A–7C at section 107, MOSFET transistors Q3, Q4, Q5, and Q6 have their gates connected to the micro-controller at section 101 output lines 1–4 at section 105, respectively. If output lines 1 and 2 are brought to a digital "1" state and output lines 3 and 4 are at a digital "0" state, current flows through transistors Q3 and Q4 causing the motor to turn at a speed in proportion to the amount of time that the transistors are switched on. Full speed indicates that the transistors are switched on all the time. If output lines 3 and 4 are brought to a digital "1" state and output lines 1 and 2 are at a digital "0" state, current flows through transistors Q5 and Q6 causing the motor to turn at a speed in proportion to the amount of time that the transistors are switched on in the opposite direction. The controllable filter network helps reduce physical vibrations created in the motor armatures due to the sharp rise time of the pulses. Referring back to FIG. 20, the motor control aspects are contained within section 605. The software branches at section 606 back to FIG. 11 at section 514 to begin receiving a new preamble.

Referring now to FIG. 18 at section 595, this is the entry point for an interrupt routine 596. As the word interrupt implies, there is not a particular branch to this routine. Whenever a sound effect nears the end of playback, a signal is generated. This signal triggers an interrupt and causes an immediate branch to this routine. This signal is then monitored at section 597 until the sound effect has completed playback. Once completed, the sound effect is checked to see if it should be repeated or looped at section 598. If it should be looped, the sound effect is replayed at section 599. Once the sound effect is replayed or allowed to lapse, the software then returns to the point of the original branch at section 600.

Referring now to FIG. 11 at section 513, numerous configuration variables are contained within the present invention. Examples of the configuration variable include programmable device address, volume settings, breakpoints and

motor characteristics such as acceleration, deceleration and speed tables. Many of these CV's are defined by the NMRA standards. Others are reserved for uses defined and specified by individual manufacturers. Configuration variables are pre-programmed by the manufacturers with values which would be acceptable to many end users. However, some model train enthusiasts may desire to alter some or all of these configuration variables to enhance operation based upon unique installations. Section 513 checks to see if a received data packet is intended to alter configuration variables. If it is, a branch at section 520 is taken to FIG. 15 at section 545. In section 546, the configuration variable address is extracted. In section 547, the configuration variable data is written. In section 548, an acknowledgment is issued. An acknowledgment may consist of a motor lurch, a light flash or both. The acknowledgment gives the end user an indication that the programming has been accomplished. The software branches at section 549 back to FIG. 11 at section 514 to begin receiving a new preamble.

It should be understood that various changes and modifications to the presently preferred embodiments described herein will be apparent to those skilled in the art. Such changes and modifications may be made without departing from the spirit and scope of the present invention and without diminishing its attendant advantages. It is, therefore, intended that such changes and modifications be covered by the appended claims.

We claim:

[1. A sound reproducing system for a model train traveling on a plurality of rails that uses a amplified digital control signal for propulsion and control, the system comprising:

a sound memory storing a plurality of sound effects at predetermined addresses;

a controller connected to the sound memory for recalling the sound effects of either one or a plurality of sound effects in a predetermined sequence or a random sequence;

a sound memory containing multiple samples that emulate a model locomotive at various speeds and work loads;

an integrated sound, motor and special effects controller controlled by a bi-polar digital signal, the motor and special effects controller re-producing the stored sounds contained in the model train; and

a digital packet triggering a sound effect for automatic playback of a sound effect.]

[2. The system according to claim 1 wherein the model train has two rails for providing a digital signal and powering the sound effects of the model train, motor, and special effects system.]

[3. The system according to claim 1 further comprising:

an electrical power supply in the rail car or track side structure having a means for collecting the digital bi-polar signal from either of the two insulated tracks by a pick up on two insulated wheels or off of a digital buss line or overhead wire;

a full wave bridge rectifier with an input connected to a bi-polar digital signal with an output producing a DC voltage regardless of the phase of the bi-polar signal;

a regulated power supply connected to a full wave bridge rectifier supplying power to the sound reproducing system; and

a regulated power source for the audio amplifiers.]

[4. The system according to claim 1 further comprising: means for simultaneously decoding a properly addressed digital control packet for control of the model loco-

23

tive's electric motor, control of the sound functions and on board special effects.]

[5. The system of claim 1 further comprising the steps of: a fixed external source of either AC or DC power and means for connecting a bi-polar digital signal to the sound unit;

means for filtering the low level signal noise in the reception of the bi-polar digital signal for power and control of the sound unit.]

[6. The system of claim 1 further comprising:

means to synchronize sound effects through the use of a Hall effect sensor to trigger a plurality of speed sensitive sounds located in a model train locomotive or rail car based on a digital speed packet wherein the speed sensitive sounds are stored in the memory and include various samples that emulate different speeds and loads;

a controller that recalls the same plurality of synchronized sound effects at intervals appropriate to the speed of the locomotive depending on a digital command control speed packet wherein the same controller recalls a plurality of synchronized sound effects at intervals appropriate to the speed of the locomotive using a speed sync sensor and further wherein the controller recalls asynchronous sound effects from the same memory or from additional memories for sound on sound.]

[7. The system of claim 1 wherein the controller activates an automatic steam release sound effect upon sensing a zero speed packet with the correct address header and further activates an appropriate air compressor sound effect upon sensing the same zero speed packet and correct address header and still further activates lighting effects or other onboard special effects after receiving and decoding the properly addressed digital control packet.]

[8. The system of claim 1 further comprising:

a controller that will decode a three byte packet with an addressed header that matches the sound unit's discreet address in the range of 1 to 127 addresses for controlling a model train locomotive motor, sound effects and onboard special effects.]

[9. The system of claim 1 further comprising:

a controller that decodes a four byte packet with an address header that matches the sound units discreet address in the address range of 1 through 9999 for controlling a model train locomotive motor, sound effects and onboard special effects.]

[10. The system of claim 1 further comprising:

means for synchronizing the sound effects to the driver's wheels through decoding a properly addressed digital speed packet that controls the speed of the model locomotive and determines which sound effect to synchronize with the speed of the locomotive using the same digital speed packet.]

[11. The system of claim 1 further comprising:

a Hall effect sensor to sense a change of speed of wheels of a steam locomotive to trigger the proper speed sound effect by mounting a magnet to the rear of a drive wheel to form a switch closure for synchronization of the sound effect to the digital speed control packet.]

[12. The system of claim 1 further comprising:

a micro-controller that decodes a predetermined addressed digital signal for control of sound effects, model train propulsion and on board special effects wherein the micro-controller is operatively connected to the analog sound storage of the sound effects wherein the analog sound storage has a predetermined set of sounds at specific addresses; and

24

a controller that is connected to special effects outputs that control lighting and other onboard effects.]

[13. The system of claim 12 wherein the micro-controller controls the volume of the plurality of sound effects contained in a rail car.]

[14. The system of claim 12 wherein the micro-controller is configured for changing the break points to control a plurality of sound effects as related to the speed of a model locomotive, using either 14, 28 or 128 steps of speed control resolution using control variables.]

[15. The system of claim 12 further comprising:

means for changing the break points at which the digital speed packet triggers the related sound effects through end user accessible software on the micro-controller or as defined as configuration variables.]

[16. The system of claim 1 further comprising:

a plurality of digitized sounds that are controlled by the controller that receives a bi-polar digital signal.]

[17. The system of claim 1 wherein the enabling means is an internally triggered Hall-effect sensor responding to a change in a magnetic field.]

[18. The system of claim 1 further comprising:

a magnet; and

a pendulum on which the magnet is suspended wherein motion causes the magnet to transpose resulting in a change in the magnetic field.]

[19. The system of claim 1 further comprising:

a microphone constructed and arranged to record the at least one additional characteristic sound on the sound module means.]

[20. The system of claim 1 wherein the activation means is a magnetically responsive sensor constructed and arranged near a magnetic field, the magnetic field altered by a magnet.]

21. A sound reproducing system for a model train traveling on a plurality of rails that uses an amplified digital control signal for propulsion and control, the system comprising:

a sound unit;

a memory within the sound unit wherein the memory stores a plurality of sound effects at addresses wherein the sound effects contain multiple samples that emulate a train locomotive at various speeds and various work-loads wherein the memory has an analog wave form representing sound effects of a locomotive at the various speeds and the various work-loads or a digital representation of the analog wave form that represents a plurality of sound effects of a locomotive at the various speeds and the various work-loads wherein the sound effects simulate the various speeds and the various work-loads by comparing the on-off rate of a sensor to a digital speed packet; and

a controller connected to the memory for recalling at least one of the sound effects wherein the controller is controlled by a digital signal.

22. The system of claim 21 wherein the sound effects are at pre-determined addresses.

23. The system of claim 21 wherein the controller recalls a plurality of sound effects.

24. The system of claim 23 wherein the plurality of sound effects are recalled in a predetermined sequence.

25. The system of claim 23 wherein the plurality of sound effects are recalled in a random sequence.

26. The system of claim 21 wherein the various conditions include various speeds.

27. The system of claim 21 wherein the various conditions include various work-loads.

28. The system of claim 21 wherein the memory includes a plurality of special effects stored therein and further wherein the model locomotive includes a motor wherein the controller controls the motor.

29. The system of claim 21 wherein the digital signal is a bi-polar digital signal.

30. The system of claim 21 wherein the digital signal is a digital packet wherein the digital packet triggers the sound effect.

31. The system of claim 21 further comprising:

an electrical power supply connected to at least one of the plurality of rails;

a pick-up means for collecting the digital signal; and

a full-wave bridge rectifier connected to the electrical power supply and further having an input for receiving the digital signal and an output wherein the output produces a DC voltage without regard to phase of the digital signal.

32. The system of claim 21 wherein the memory includes a plurality of special effects stored therein and further wherein the model locomotive includes a motor and means for simultaneously decoding the digital signal for control of the sound effects, the motor and/or the special effects.

33. The system of claim 21 further comprising:

a fixed external source of electrical power;

means for connecting the digital signal to the sound memory; and

means for filtering the digital signal.

34. The system of claim 21 further comprising:

a speed sync sensor in the controller wherein the controller recalls a plurality of speed sensitive sounds to emulate a speed of the train locomotive based on a speed of the model train wherein the speed sync sensor synchronizes the speed sensitive sounds with the speed of the model train.

35. The system of claim 21 wherein the controller recalls the sound effects in an asynchronous or synchronous manner.

36. The system of claim 21 further comprising:

a second memory for storing the plurality of sound effects.

37. The system of claim 21 further comprising:

a discrete address in the range of 1 to 127 contained within the sound unit wherein the digital signal includes a three byte packet wherein the three byte packet includes an address header that matches the discrete address.

38. The system of claim 21 further comprising:

a discrete address in the range of 1 to 9999 contained within contained within the sound unit wherein the digital signal includes a four byte packet wherein the four byte packet includes an address header that matches the discrete address.

39. The system of claim 21 further comprising:

wheels on the model locomotive;

a digital packet within the digital signal for controlling a speed of the model locomotive; and

means for synchronizing the plurality of sound effects to the wheels of the model locomotive wherein the synchronization means decodes the digital packet and further wherein the synchronization means determines which sound effect to synchronize with the speed of the model locomotive using the digital packet.

40. The system of claim 21 wherein the memory includes a plurality of special effects stored therein and further wherein the model locomotive includes a motor and further wherein the model locomotive includes a micro-controller that decodes a digital signal for control of the sound effects, the motor and/or the special effects.

41. The system of claim 21 wherein the memory includes a plurality of special effects stored therein wherein the special effects include a lighting special effect and further wherein the controller controls the special effects.

42. The system of claim 40 wherein the plurality of sound effects has a volume controlled by the micro-controller.

43. The system of claim 40 wherein the sound effects are divisible by 14, 28 or 128 speed steps controlled by the micro-controller.

44. The system of claim 40 wherein the micro-controller is programmed to control the sound effects.

45. The system of claim 21 wherein the sound effects are digitized.

46. The system of claim 21 further comprising:

a microphone on the sound unit for recording an additional sound effect.

47. The system of claim 21 further comprising:

an activation means for activating the sound effect wherein the activation means is a magnetically responsive sensor.

48. The system of claim 21 further comprising:

means for controlling a variable filter network wherein the variable filter network suppresses audible noise.

49. The system of claim 21 wherein the sound effects include a sample that emulates a train locomotive at multiple speeds.

50. The system of claim 21 wherein the stored sound effects are analog.

51. The system of claim 21 wherein the controller is an integrated sound, motor, and special effects controller.

52. The system of claim 21 wherein the controller is controlled by a bi-polar digital signal.

53. The system of claim 21 wherein the controller recalls the sound effects of either one or a plurality of sound effects in a predetermined sequence or a random sequence by means of a bi-polar digital signal.

54. The system of claim 21 wherein the sound effects are replicating momentum effects using steam or diesel sound effects.

55. The system of claim 21 further comprising:

a first circuit board having a plug; and

a second circuit board having a socket wherein the plug of the first circuit board connects to the socket of the second circuit board.

56. The system of claim 21 further comprising:

a controllable filter network reducing vibrations in a motor.

57. The system of claim 21 wherein a sound unit, with a register fixed in firmware or programmable for control variables wherein the control variables are one of acceleration, deceleration, start voltages, motor response curves, momentum sound effects, load factor sound effects, coasting sound effects, means to synchronize or de-synchronize sound effects to the rotation of wheels and control of a filter network for motor noise snubbing.