

US00RE40653E

(19) **United States**
(12) **Reissued Patent**
Fleming, III

(10) **Patent Number:** **US RE40,653 E**
(45) **Date of Reissued Patent:** ***Mar. 10, 2009**

(54) **RADAR DETECTOR FOR DETECTING
POLICE RADAR THAT RECEIVES GPS DATA**

(76) Inventor: **Hoyt A. Fleming, III**, 4134 W. Quail
Ridge Dr., Boise, ID (US) 83703

(*) Notice: This patent is subject to a terminal dis-
claimer.

(21) Appl. No.: **11/196,841**

(22) Filed: **Aug. 2, 2005**

Related U.S. Patent Documents

Reissue of:

(64) Patent No.: **6,204,798**
Issued: **Mar. 20, 2001**
Appl. No.: **09/292,089**
Filed: **Apr. 14, 1999**

U.S. Applications:

(63) Continuation of application No. 10/352,679, filed on Jan. 28,
2003, now Pat. No. Re. 39,038.

(51) **Int. Cl.**
G01S 7/40 (2006.01)
G01S 13/00 (2006.01)

(52) **U.S. Cl.** **342/20; 342/52; 342/89;**
342/195; 342/357.06; 342/357.1; 342/357.17

(58) **Field of Classification Search** **342/20,**
342/26 R-26 D, 27, 52, 83, 90-93, 104, 105,
342/109, 115, 118, 159, 165, 175, 195, 357.01,
342/357.06, 357.1, 357.13, 357.17, 146-158;
370/901-905, 933, 936, 988, 989, 991; 340/933-936
See application file for complete search history.

(56) **References Cited**

U.S. PATENT DOCUMENTS

3,660,844 A * 5/1972 Potter 342/20
4,313,216 A * 1/1982 Jaeger et al. 342/20
4,750,215 A * 6/1988 Biggs 342/20
4,906,999 A * 3/1990 Harrah et al. 342/20
4,949,088 A * 8/1990 Ryan et al. 342/20

5,068,663 A * 11/1991 Valentine et al. 342/20
5,083,129 A * 1/1992 Valentine et al. 342/20
5,151,701 A * 9/1992 Valentine et al. 342/20
5,250,951 A * 10/1993 Valentine et al. 342/20
5,977,884 A * 11/1999 Ross 340/936
6,049,301 A * 4/2000 Weagant 342/20
6,118,403 A * 9/2000 Lang 342/20
6,252,544 B1 6/2001 Hoffberg 342/357.1
6,670,905 B1 12/2003 Orr
RE39,038 E * 3/2006 Fleming, III 342/20

OTHER PUBLICATIONS

“Buyers Guide: Radar Detectors”; no author listed; no date
given; copyright 2002–2006; on the Internet at radarbuster-
s.com.*

Dr. Tom J. Chalko, “High accuracy speed measurement
using GPS (Global Positioning System)”; Scientific Engi-
neering Research P/L; Mount Best, Victoria, Australia; no
date listed; copyright in the year 2007.

Poteet, David C., “RadioSat”; on the Internet at newcityme-
dia.com; no date given; copyright 1995–1997; last modified
Oct. 6, 1998.*

U.S. Appl. Ser. No. 60/108,362, filed Nov. 13, 1988, never
published.*

U.S. Appl. Ser. No. 60/139,097 filed Jun. 1999 Steven K.
Orr.

U.S. Appl. Ser. No. 60/145,394 filed Jul. 1999 Steven K. Orr.

* cited by examiner

Primary Examiner—Bernarr E Gregory

(57) **ABSTRACT**

A radar detector for alerting an operator of a motor vehicle
to an incoming police radar signal. This radar detector
includes a microprocessor; a circuit coupled to the micropro-
cessor for detecting the incoming police radar signal; and a
global positioning system receiver coupled to the micropro-
cessor. Upon detection of an incoming radar signal, the radar
detector can utilize the position, velocity, and/or heading
data from the global positioning system receiver to deter-
mine whether to generate an alert.

30 Claims, 2 Drawing Sheets

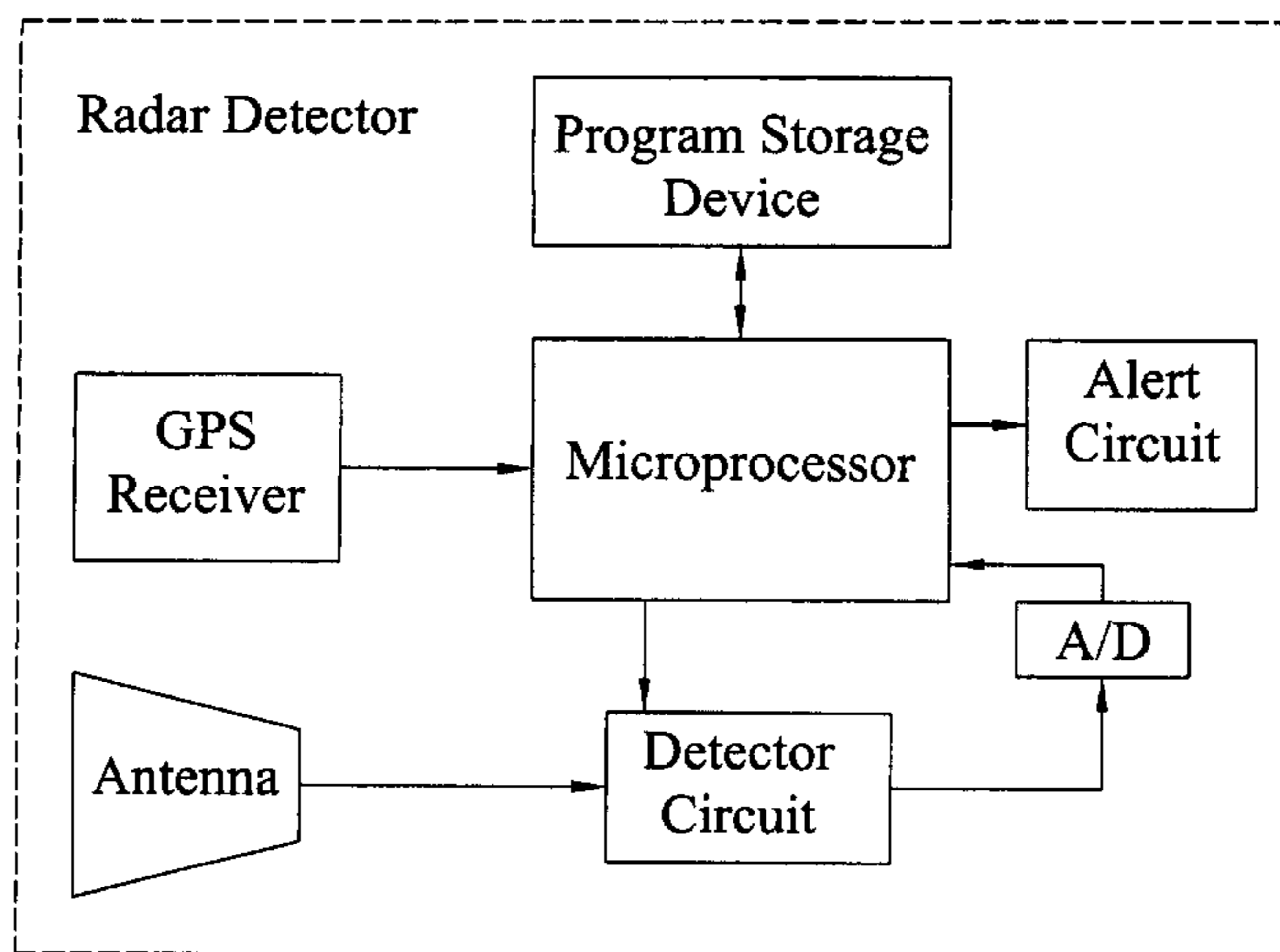

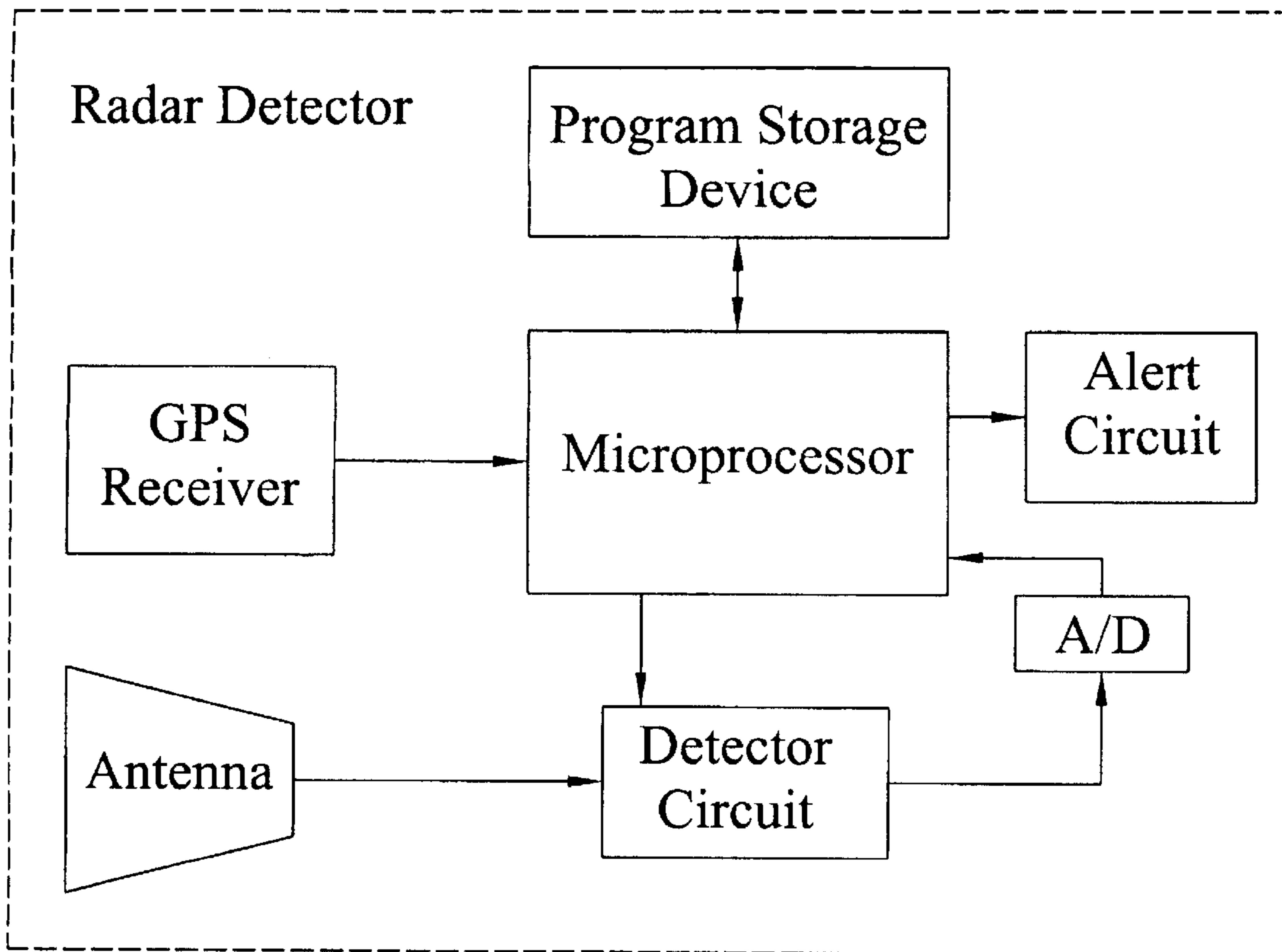

Fig. 1

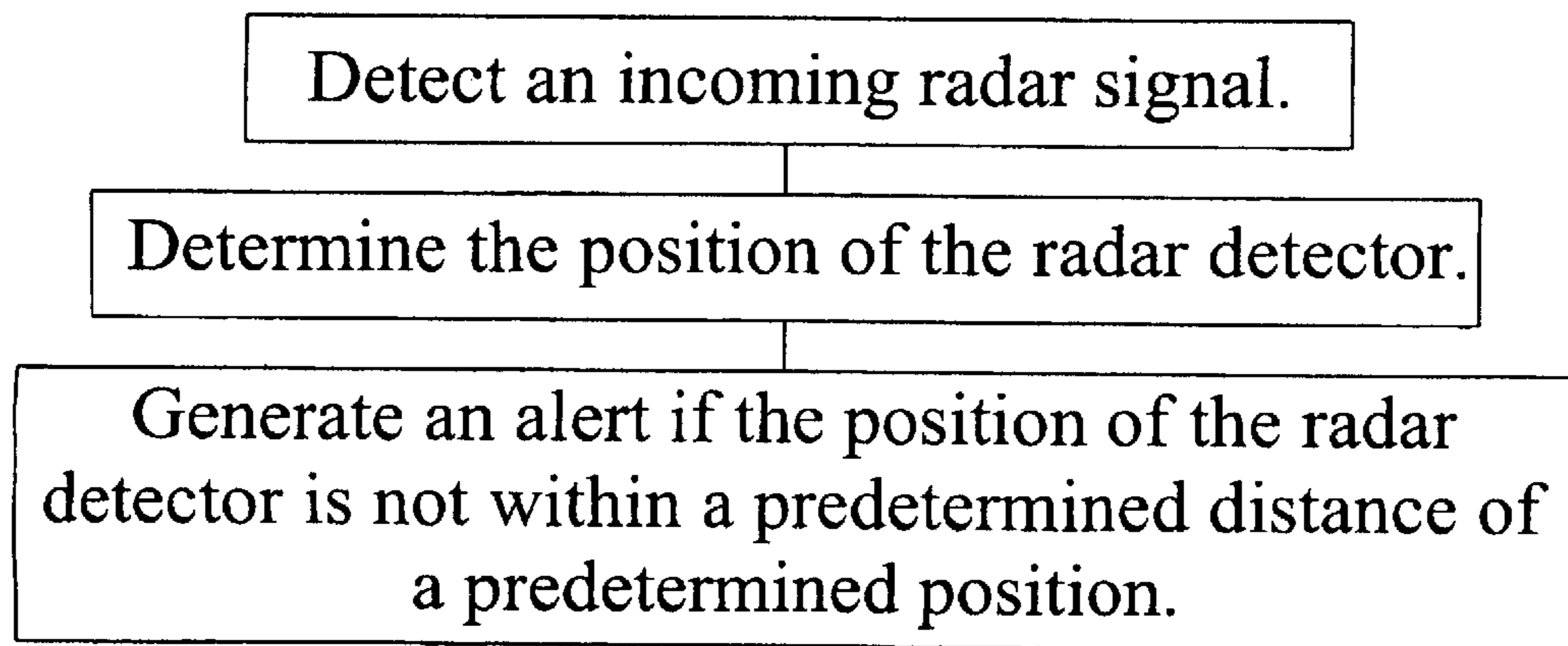

Fig. 2

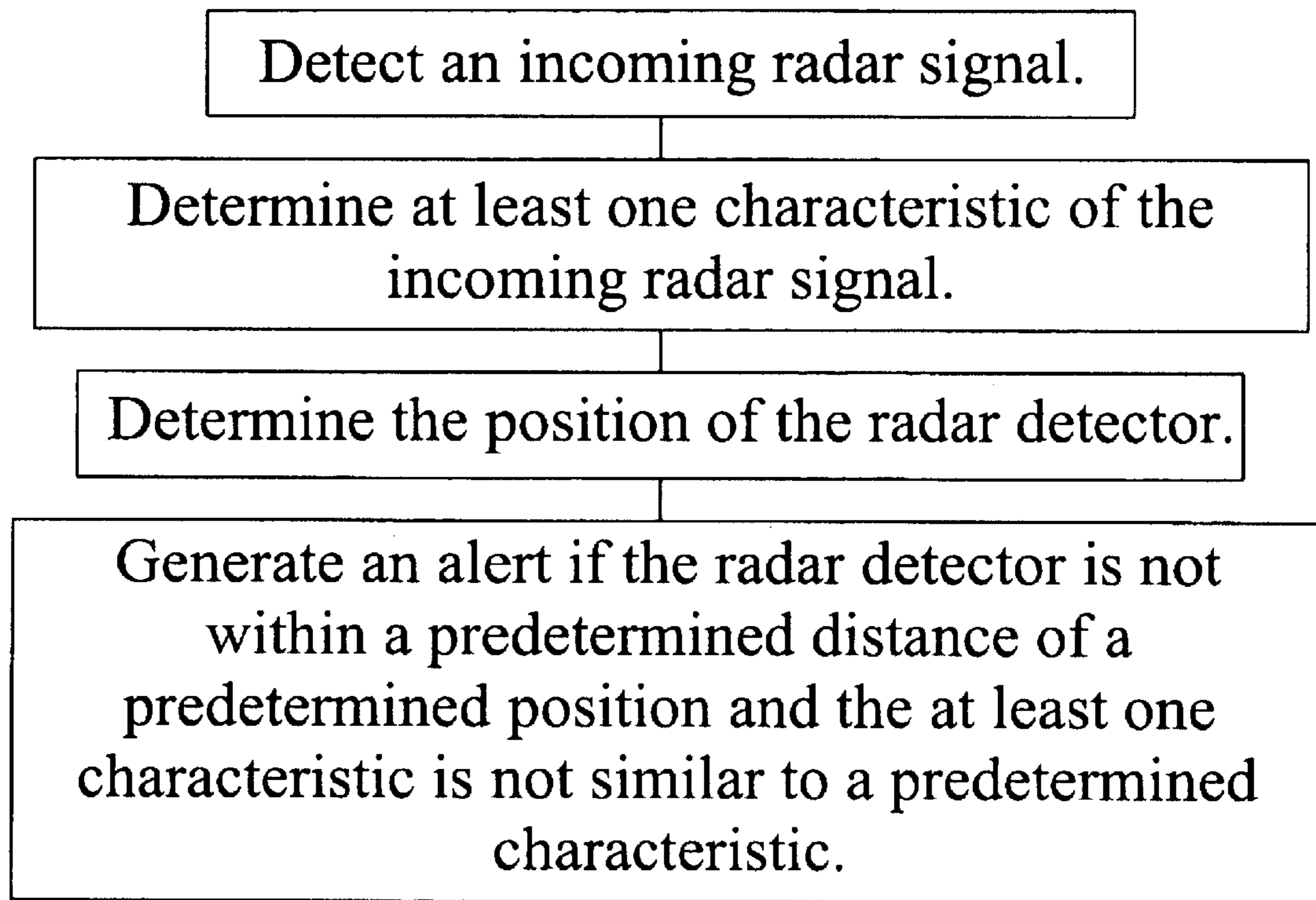

Fig. 3

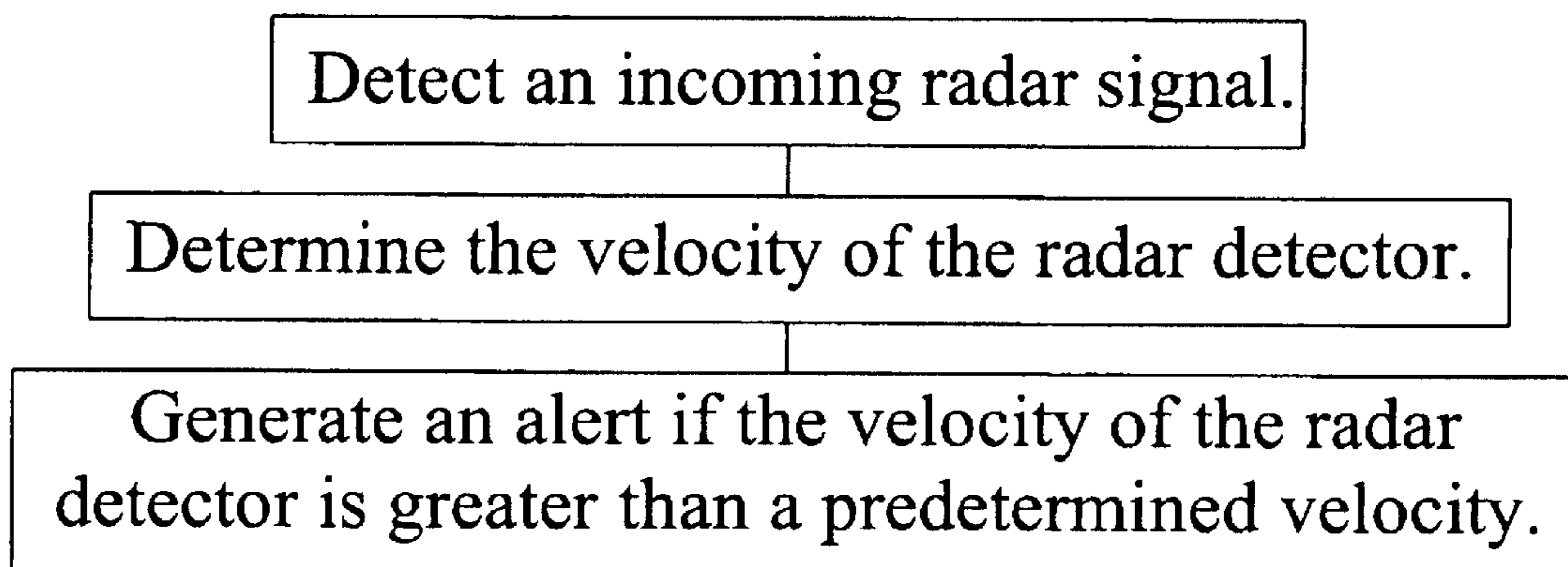

Fig. 4

RADAR DETECTOR FOR DETECTING POLICE RADAR THAT RECEIVES GPS DATA

Matter enclosed in heavy brackets [] appears in the original patent but forms no part of this reissue specification; matter printed in italics indicates the additions made by reissue.

This application is a continuation of U.S. patent application Ser. No. 10/352,679, filed on Jan. 28, 2003 now Reissued U.S. Pat. No. Re. 39,038, which is a Reissue of U.S. Pat. No. 6,204,798, which issued from U.S. patent application Ser. No. 09/292,089, filed on Apr. 14, 1999.

1. BACKGROUND

The present invention relates generally to police radar detectors used in motor vehicles and, more particularly, to police radar detectors that utilize a motor vehicle's position, velocity and/or heading to minimize false alarms.

Many operators of motor vehicles utilize radar detectors to alert them to the fact that their speed is being monitored by law enforcement agencies. However, conventional radar detectors often generate "false alarms." These false alarms are annoying to the operators of motor vehicles. In fact, various automotive publications publish results of "false alarm" tests. Thus, anything that can be accomplished by the manufacturer to reduce the number of false alarms without reducing detection of police radar is commercially valuable.

In addition to police radar signals, there are many different sources of microwave signals in the frequency bands allocated to police radar by the U.S. Federal Communications Commission (FCC). For example, motion-detecting burglar alarms and automatic door openers also operate in the frequency band allocated to police radar. Thus, a need exists for a radar detector that can distinguish between signals generated by a police radar transmitter and those generated by other devices which utilize microwave signals within the same frequency bands.

Still another source of annoying false alarms occurs when an operator of a motor vehicle is travelling at a speed that is below the legal speed limit, such as occurs when the operator is in traffic, and the radar detector alerts him to an incoming radar signal. Even if a police radar signal is monitoring the speed of the operator's vehicle, because the velocity of the vehicle is below the legal speed limit, the operator of the vehicle may not need to be alerted to the presence of the police radar signal. Thus, a need exists for a radar detector that does not generate an alert if the velocity of the radar detector is below the legal speed limit.

Operators have become accustomed to radar detectors activating in certain locations along commonly traveled streets and highways. Police radar units may be deployed by the side of the roadway at these locations since the police also are aware of the local activation signals and the police are aware that the signals tend to mask their own speed monitoring radar units. Thus, a need exists for a radar detector that can avoid generating a false alarm due to such accustomed radar signals while still generating an alert for such police radar signals.

2. SUMMARY OF THE INVENTION

One embodiment is a radar detector for alerting an operator of a motor vehicle to an incoming police radar signal. This radar detector includes a microprocessor; a circuit coupled to the microprocessor for detecting the incoming police radar signal; and a global positioning system receiver

coupled to the microprocessor. The radar detectors also includes a program storage device containing instructions for determining whether to generate an alert to an incoming radar signal based upon the radar detector's position, velocity and/or heading.

Another embodiment of the invention is a method of generating an alert to an incoming radar signal. This method includes first detecting the incoming radar signal. Next, the position of a radar detector is determined. Then, an alert is generated if the position of the radar detector is not within a predetermined distance of a predetermined position.

Still another embodiment of the invention is a second method of generating an alert to an incoming radar signal. This method includes first detecting the incoming radar signal. Next, the velocity of the radar detector is determined. Then, an alert is generated if the velocity of a radar detector is greater than a predetermined velocity.

BRIEF DESCRIPTION OF THE DRAWINGS

FIG. 1 is a block diagram of a radar detector including one embodiment of the present invention.

FIG. 2 is a flow diagram of a method of operating a radar detector.

FIG. 3 is a flow diagram of another method of operating a radar detector.

FIG. 4 is a flow diagram of yet another method of operating a radar detector.

3. DETAILED DESCRIPTION OF THE PREFERRED EMBODIMENTS

3.1 Description of a First Embodiment

One embodiment of the novel radar detector is shown in FIG. 1. The radar detector includes an antenna that is coupled to a detector circuit. The detector circuit, which may be controlled by the microprocessor of FIG. 1, collects the signals from the antenna, detects the incoming signals, and distinguishes valid radar signals from electrical noise. The detector circuit may be any appropriate radar detector circuit capable of generating an output signal which indicates the strength, the presence, and/or the frequency of incoming radar signals. While the detector circuit may operate autonomously, operation and control of the detector circuit may be performed by the microprocessor. For example, the microprocessor may control the detector as is known in the art so that radar signals in the different frequency bands allocated to police radar signals are detected. Such detector circuits can take a wide variety of forms and can include amplifiers, mixers, diplexers, and other circuitry commonly used in the radar detector field. Several examples of such circuits are shown in U.S. Pat. Nos. 4,313,216, 5,068,663, and 5,250,951, which are incorporated herein by reference.

The output of the detector circuit is coupled to the input of one or more analog-to-digital converters. These converters convert the analog output of the detector circuit into digital signals that represent signal strength, signal presence, and/or signal frequency.

In addition to being coupled to the detector circuit and the analog-to-digital converter, the microprocessor is also coupled to an alert circuit. The alert circuit communicates information regarding detected radar signals to the operator of a motor vehicle using the radar detector by means of one or more alarm tones and/or visual indicators that are included within the alert circuit. Alert circuits are known by those skilled in the art. For example, see U.S. Pat. Nos. 4,313,216, 5,068,663, and 5,250,951, which are incorporated herein by reference.

The microprocessor, which may be any conventional single or multiple chip microprocessor or digital signal processor, is coupled to a program storage device. The program storage device may be any conventional memory device such as a PROM, EPROM, EEPROM, ROM, SRAM or even battery backed up DRAM. The program storage device contains machine readable instructions that command the microprocessor to perform certain functions. For example, the program storage device may be conventionally programmed to sweep a predetermined number of radar frequency bands, determine the frequency and/or signal strength of any detected radar signals in the swept frequency bands, and, if the signal strength of the detected radar signals exceed a predetermined value, then generate a signal that activates the alert circuit. Such programming is known by those skilled in the art. For example, see U.S. Pat. Nos. 4,313,216, 5,068,663, and 5,250,951, which are incorporated herein by reference.

The microprocessor is also coupled to a positioning system such as a global positioning system ("GPS") receiver. As is well known, a GPS receiver receives signals from satellites and uses these signals to calculate the position of the GPS receiver. In addition, the GPS receiver may receive differential correction data and/or dead reckoning data, such as from a compass or a wheel sensor, to increase the accuracy of the receiver. By calculating the position of the GPS receiver at two different times, the velocity and heading of the GPS receiver can be easily determined using conventional algorithms. Thus, the GPS receiver can provide the microprocessor with data that indicates the position, the velocity, and/or the heading of the radar detector.

The microprocessor may also be coupled to a user interface circuit (not shown). The user interface circuit may include a plurality of buttons that are intended to be depressed by an operator of a motor vehicle. Such buttons may include: a power button, a mute button, a city/highway button, and a dim button.

As will be discussed more fully below, the program storage device may also contain machine readable instructions that command the microprocessor to determine whether to generate an alert based upon data received from the GPS. Thus, upon detection of an incoming radar signal, the radar detector can utilize the position, velocity, and/or heading data from the global positioning system receiver to determine whether to generate an alert.

3.2 Description of a Second Embodiment

One method of operating the radar detector of FIG. 1 is shown in FIG. 2. In this embodiment, the radar detector first detects an incoming radar signal. Next, the position of the radar detector is determined. Then, an alert is generated if the position of the radar detector is not within a predetermined distance of a predetermined position.

By utilizing the above method, many false alarms may be eliminated. For example, if the position of a microwave automatic door opener is programmed into the radar detector and the radar detector detects an incoming radar signal when the radar detector's position is near the automatic door opener, then it is likely that the source of the incoming radar signal is the automatic door opener and not a police radar. Thus, using the method of FIG. 2, an alert would not be generated for the detected radar signal.

The programming of predetermined positions may be accomplished by depressing one or more buttons that are coupled to the interface circuit discussed above. Thus, if an operator of a motor vehicle approaches a microwave automatic door opener, then the operator can depress an "ignore radar" button. Then, the radar detector would store the posi-

tion of the radar detector and possibly the frequency and the signal strength of the incoming radar signal in the program storage device of FIG. 1 or another memory device (not shown) coupled to or integrated within the microprocessor. An alternative method of storing such data would be to hold down a "mute" button for an extended length of time such as 3 to 5 seconds. It is also possible to experimentally generate a database containing position, frequency and/or signal strength for a specific geographical region. This database could be provided to operators of motor vehicles for a fee. Accessing the Internet via a cellular phone (not shown) coupled to the microprocessor of FIG. 1 would be one method of providing the above database to operators of motor vehicles.

In still another embodiment, when the operator instructs the radar detector to store a position of an incoming radar signal, the radar detector could attempt to locate the approximate position of the source of the incoming radar signal. For example, if an operator instructs the radar detector to store a position of an incoming radar signal as the operator is still approaching the source of the incoming radar signal, the signal strength of the incoming radar signal will be increasing. The radar detector could locate a position that is very near the position of the source of the incoming radar signal by determining the position of the radar detector when the strength of the incoming signal is at a maximum. In addition, radar detectors such as described in U.S. Pat. No. 5,250,951, may utilize multiple radar antennas and signal processing logic to more accurately determine the position of the source of the incoming radar signal. For example, the position of the source of many incoming radar signals may be closely approximated by the position of a radar detector when the radar detector identifies that the radar source is to the side of the vehicle.

The predetermined distance may also be programmed by the operator of the motor vehicle. If the GPS receiver is receiving differential correction data or is receiving dead reckoning data, then the predetermined distance may be set to a smaller value because the position of the radar detector may be more precisely determined. In addition, if the strength of the incoming radar is strong, the predetermined distance could be set (manually or automatically) to a higher value because the radar detector will detect the incoming radar signal at a greater distance from the source. For example, if a radar detector in a vehicle detected a radar signal while the vehicle traveled a 1 mile distance, then the predetermined distance for that particular radar signal may be calculated by dividing the 1 mile distance in half. In order to compensate for non-symmetrical detection of the radar signal and inaccuracies of the positioning of the radar detector, an additional $\frac{1}{4}$ or $\frac{1}{2}$ mile might be added to the above predetermined distance.

3.3 Description of a Third Embodiment

The simple method of operating a radar detector shown in FIG. 2 can be improved as shown in FIG. 3. In this embodiment, the after the radar detects an incoming radar signal it determines a characteristic of the radar signal. For example, the radar detector may determine the frequency and/or the signal strength of the incoming radar signal. Next, the position of the radar detector is determined. Then, an alert is generated if the radar detector is not within a predetermined distance of a predetermined position and the characteristic is not similar to a predetermined characteristic.

By utilizing this method, many false alarms may be eliminated. For example, the location of a microwave automatic door opener and the frequency of the radar signal transmitted by the door opener are first programmed into a radar detec-

tor. Assume that a police radar is being transmitted near the location of the microwave automatic door opener. Because the police radar is near the automatic door opener, the method of FIG. 2 would not generate an alert. Thus, the operator of a motor vehicle would not be properly alerted to the police radar. However as shown below, the method of FIG. 3 would generate an alert.

If the automatic door opener signal is processed first according to the method of FIG. 3, then the frequency of the automatic door opener signal would be determined. Next, the position of the radar detector would be determined. Because the radar detector is near the previously programmed position of the automatic door opener and the frequency of the incoming radar signal is equal to the previously programmed frequency of the automatic door opener, the radar detector would not generate an alert.

Next, the police radar signal would be processed. Thus, the frequency of the police radar signal would be determined. However, even though the location of the radar detector is near the previously programmed location of the automatic door opener, because the frequency of the police radar is not equal to the previously programmed frequency of the radar signal transmitted by the door opener, an alert would be generated. Thus, the operator of the motor vehicle would be properly alerted to the presence of the police radar signal.

Due to inaccuracies in algorithms and slight variations in frequencies due to physical phenomena such as temperature of radar transmitters, it may not be practical to determine if a frequency of an incoming radar signal is exactly equal to a previously programmed frequency. Thus, it is often sufficient to determine if the frequency of an incoming radar signal is similar to a previously programmed frequency. For example, if two frequencies are within 1/2, 1, 2, 3, 4, or 5 MHz of each other, then they may be considered to be similar.

In one embodiment of the invention, 256 frequency bins are defined for each frequency band of the radar detector. Thus, this one embodiment of the invention, each of the following frequency bands would have 256 bins: X band (10.475–10.575 GHz); Ku band (13.400–13.500 GHz); K band (24.025–24.275 GHz); and Ka band (34.150–35.250 GHz). In this embodiment, frequencies are considered to be similar if they are in the same frequency band and are in the same bin. In still another embodiment, frequencies are considered to be similar if they are in the same frequency band and are in the same or adjacent bins. In these two embodiments, the exact frequency of the incoming radar signal need not be determined. Only the frequency band and the appropriate frequency bin number need be determined. If higher resolution is required, then the number of bins for one or more frequency bands can be increased. On the other hand, if only very low resolution is required, then if two frequencies are in the same frequency band, they may be considered to be similar.

3.4 Description of a Fourth Embodiment

FIG. 4 shows still another method of operating the radar detector of FIG. 1. In this embodiment, the radar signal is first detected. Then, the velocity of the radar detector is determined. Next, an alert is generated if the velocity of the radar detector is greater than a predetermined velocity.

This embodiment is particularly useful if the predetermined velocity is set to a value that is less than the minimum speed limit. For example, if an operator of a motor vehicle programs the predetermined velocity to 65 miles per hour, which may be the speed limit on a particular highway, then the operator will not be alerted to a radar signal unless he is speeding. Thus, the operator will not be alerted to radar signals when he is traveling at a slow rate of speed such as when

the operator is in traffic. The operator could also program the predetermined velocity to the minimum speed limit that the operator is likely to encounter in a specific geographical region. For example, if the city in which the operator lives has some streets with a 25 miles per hour speed limit, then the operator could program the predetermined speed to 25 miles per hour. If the operator performed such programming, such as by depressing one or more buttons that are coupled to the interface circuit, the operator could be spared some, but not all false alarms.

A more sophisticated embodiment would not require the user to manually program the speed limit. This embodiment would obtain the speed limit from a database that contains speed limits for particular roads in a geographic region. By comparing the location and/or the heading of a motor vehicle to the location and/or heading of a plurality of roads in the above database, the radar detector could determine the particular road upon which the vehicle is traveling. After such a determination, the speed limit for the particular road could be accessed from the database. Such algorithms are known by those skilled in the art. This database could be stored on the program storage device of FIG. 1 or could be stored on an external storage device such as a CD ROM or a hard disk drive. This database could also be provided to operators of motor vehicles for a fee.

3.5 Other Embodiments

In some cases, an operator of a motor vehicle may desire to be alerted to the presence of a radar signal even if the above methods would not “generate an alert.” In such cases, a less intrusive alert such as a reduced volume tone, and/or a flashing LED could be generated. Thus, the phrase “generate an alert if” a condition occurs is intended to include generating a particular alert if the condition occurs. If another condition occurs, such as detection of an incoming radar signal while the radar detector is within a predetermined distance of a predetermined position as shown in FIG. 2, then another alert may be generated.

The above Description of the Preferred Embodiments includes words, such as “first,” “then,” and “next.” These words indicate a sequence of acts. Many of the sequences can be modified within the scope of the invention. Thus, unless the result of a first act is required for a second act, then the language indicating a sequence should not be considered to be limitations to the invention.

Many of the above embodiments can be combined to produce a radar detector that generates very few false alarms. For example, the methods of FIG. 2 or FIG. 3 can be combined with the method of FIG. 4. Such combinations are intended to be within the scope of the invention.

I claim:

[1. A method, executed by a device having a position, of generating an alert to an incoming radar signal having a frequency and a signal strength, the method comprising the acts of:

- (a) detecting the incoming radar signal;
- (b) determining the position of the device that detected the incoming radar signal; and
- (c) generating an alert if the position of the device is not within a predetermined distance of a predetermined position.]

[2. The method of claim 1 wherein the act of detecting the incoming radar signal includes determining at least one characteristic of the radar signal.]

[3. The method of claim 2 wherein the act of determining at least one characteristic of the radar signal includes determining the frequency of the radar signal.]

[4. The method of claim 2 wherein the act of determining at least one characteristic of the radar signal includes determining a frequency bin number.]

[5. The method of claim 2 wherein the act of determining at least one characteristic of the radar signal includes determining whether the incoming radar signal is in the X frequency band, the Ku frequency band, the K frequency band, or the Ka frequency band.]

[6. The method of claim 2 wherein the act of determining at least one characteristic of the radar signal includes determining the signal strength of the incoming radar signal.]

[7. The method of claim 2 wherein the act of generating an alert includes generating an alert if the at least one characteristic is not similar to a predetermined characteristic.]

[8. The method of claim 1 wherein the act of determining the position of the device includes receiving signals from a plurality of satellites.]

[9. The method of claim 1 wherein the act of determining the position of the device includes receiving a differential global positioning signal.]

[10. The method of claim 1 wherein the act of determining the position of the device includes receiving dead reckoning data.]

[11. A method, executed by a device having a velocity, of generating an alert to an incoming radar signal having a frequency and a signal strength, the method comprising the acts of:

- (a) detecting the incoming radar signal;
- (b) determining the velocity of the device that detected the incoming radar signal; and
- (c) generating an alert if the velocity of the device is greater than a predetermined velocity.]

[12. The method of claim 11 wherein the act of determining the velocity of the device includes receiving data from a plurality of satellites.]

[13. The method of claim 11 wherein the act of determining the velocity of the device includes receiving data from a plurality of global positioning satellites.]

[14. The method of claim 11 wherein the act of determining the velocity of the device includes receiving differential global positioning data.]

[15. The method of claim 11 wherein the act of determining the velocity of the device includes receiving dead reckoning data.]

[16. The method of claim 11 wherein the act of generating an alert if the velocity of the device is greater than a predetermined velocity includes generating an alert if the velocity of the device is greater than a velocity that has been previously programmed by an operator of a motor vehicle.]

[17. The method of claim 11 wherein the act of generating an alert if the velocity of the device is greater than a predetermined velocity includes generating an alert if the velocity of the device is greater than a legal speed limit that is retrieved from a database.]

[18. A radar detector for alerting an operator of a motor vehicle to an incoming police radar signal comprising:

- (a) a microprocessor;
- (b) a circuit coupled to the microprocessor for detecting the incoming police radar signal; and
- (c) a global positioning system receiver coupled to the microprocessor and operable to provide the microprocessor with data.]

[19. The radar detector of claim 18, further including a program storage device that is coupled to the microprocessor, the program storage device containing machine readable instructions for:

- (a) determining the position of a radar detector; and
- (b) generating an alert if the position of the radar detector is not within a predetermined distance of a predetermined position.]

[20. The radar detector of claim 19, wherein the program storage device includes machine readable instructions for determining at least one characteristic of the radar signal.]

[21. The radar detector of claim 18, further including a program storage device that is coupled to the microprocessor, the program storage device containing machine readable instructions for:

(a) determining the velocity of the device utilized to detect the incoming radar signal; and

(b) generating an alert if the velocity of a radar detector is greater than a predetermined velocity.]

22. A method, executed by a radar detector for alerting an operator of a motor vehicle to an incoming police radar signal, the radar detector having a GPS receiver and a processor, the method comprising:

receiving data based at least in part upon the incoming police radar signal;

alerting the operator of the motor vehicle to the incoming police radar signal;

determining a first position of the radar detector;

determining a second position of the radar detector; and receiving data based at least in part upon the second position;

wherein the determining of the second position of the radar detector is performed by the radar detector's GPS receiver;

wherein the receiving the data based at least in part upon the second position and the receiving the data based at least in part upon the incoming police radar signal are both performed by the radar detector's processor.

23. The method of claim 22, further comprising determining the moving direction between the first position and the second position.

24. The method of claim 23, further comprising generating a visual indication based at least in part upon the moving direction.

25. The method of claim 22, wherein the radar detector includes a button, the method further comprising muting an audible alert based upon data received from the button.

26. The method of claim 25, wherein the radar detector includes non-volatile memory, the method further comprising storing data in the non-volatile memory based upon data received from the button.

27. The method of claim 25, wherein the radar detector includes non-volatile memory, the method further comprising storing the second position in the non-volatile memory based at least in part upon data received from the button.

28. The method of claim 25, wherein the radar detector includes non-volatile memory, the method further comprising storing the second position and the frequency of the incoming radar signal in the non-volatile memory based upon data received from the button.

29. The method of claim 25, wherein the radar detector includes non-volatile memory, the method further comprising storing the second position and data related to the frequency of the incoming radar signal in the non-volatile memory based upon data received from the button.

30. The method of claim 25, wherein the button is a mute button and the radar detector includes non-volatile memory, the method further comprising storing data in the non-volatile memory based upon data received from the mute button.

31. The method of claim 25, wherein the button is a mute button and the radar detector includes non-volatile memory, the method further comprising storing the second position in the non-volatile memory based upon data received from the mute button.

32. The method of claim 25, wherein the button is a mute button and the radar detector includes non-volatile memory, the method further comprising storing the second position and the frequency of the incoming radar signal in the non-volatile memory based upon data received from the mute button.

33. The method of claim 25, wherein the button is a mute button and the radar detector includes non-volatile memory, the method further comprising storing the second position and data related to the frequency of the incoming radar signal in the non-volatile memory based upon data received from the mute button.

34. The method of claim 25, wherein the button is a mute button and the radar detector includes non-volatile memory, the method further comprising performing an act that is unrelated to muting an alert based upon data received from the mute button.

35. The method of claim 25, wherein the radar detector includes non-volatile memory, the method further comprising storing the second position in the non-volatile memory based upon first data received from the button and performing an act that is unrelated to storing a position in the non-volatile memory based upon second data received from the button.

36. The method of claim 22, wherein the radar detector has a velocity, the method further comprising generating an alert if the velocity of the radar detector is greater than a predetermined velocity.

37. The method of claim 22, wherein the radar detector has a velocity, the method further comprising muting an alert if the velocity of the radar detector is less than a predetermined velocity.

38. A radar detector for alerting an operator of a motor vehicle to an incoming police radar signal, the radar detector comprising:

an alert circuit that alerts the operator of the motor vehicle to the incoming police radar signal;

a GPS receiver that determines a first position and a second position of the radar detector;

a processor, the processor receiving data based at least in part upon the second position, the processor also receiving data based at least in part upon the incoming police radar signal; and

a display that generates a visual indication based at least in part upon the second position of the radar detector.

39. The radar detector of claim 38, wherein the radar detector determines the moving direction between the first position and the second position.

40. The radar detector of claim 39, wherein the radar detector generates a visual indication based at least in part upon the moving direction.

41. The radar detector of claim 38, wherein the radar detector includes a button and the radar detector mutes an audible alert based upon data received from the button.

42. The radar detector of claim 38, wherein the radar detector includes a button and non-volatile memory and the radar detector stores data in the non-volatile memory based upon data received from the button.

43. The radar detector of claim 38, wherein the radar detector includes a button and non-volatile memory and the radar detector stores the second position and the frequency of the incoming radar signal in the non-volatile memory based upon data received from the button.

44. The radar detector of claim 38, wherein the radar detector includes a mute button and non-volatile memory and the radar detector stores data in the non-volatile memory based upon data received from the mute button.

45. The radar detector of claim 38, wherein the radar detector includes a mute button and non-volatile memory and the radar detector stores the second position in the non-volatile memory based upon data received from the mute button.

46. The radar detector of claim 38, wherein the radar detector includes a mute button and non-volatile memory and the radar detector stores at least two items in the non-volatile memory based upon data received from the mute button.

47. The radar detector of claim 38, wherein the radar detector includes a mute button and non-volatile memory and the radar detector performs an act that is unrelated to muting an alert based upon data received from the mute button.

48. The radar detector of claim 38, wherein the radar detector includes a button and non-volatile memory, and the radar detector stores data related to the second position in the non-volatile memory based upon first data received from the button and performing an act that is unrelated to storing a position in the non-volatile memory based upon second data received from the button.

49. The radar detector of claim 38, wherein the radar detector has a velocity and the radar detector generates an alert if the velocity of the radar detector is greater than a predetermined velocity.

50. The radar detector of claim 38, wherein the radar detector has a velocity and the radar detector mutes an alert if the velocity of the radar detector is less than a predetermined velocity.

51. A system, for use in an automobile, the system comprising:

a GPS receiver that outputs first data;

a plurality of antennas that receive radar signals;

signal processing logic coupled to the plurality of antennas, the signal processing logic using the received radar signals to determine positions of objects with respect to a side of the automobile;

a device, coupled to the GPS receiver and the signal processing logic, the device generating a first visual indication based at least in part upon the first data, the device generating a second visual indication based at least in part upon the positions of the objects with respect to the side of the automobile.



US00RE40653C1

(12) **EX PARTE REEXAMINATION CERTIFICATE (9520th)**
United States Patent
Fleming, III

(10) **Number:** **US RE40,653 C1**
(45) **Certificate Issued:** **Feb. 22, 2013**

(54) **RADAR DETECTOR FOR DETECTING POLICE RADAR THAT RECEIVES GPS DATA**

G01S 13/00 (2006.01)
G01S 19/48 (2010.01)
H04K 3/00 (2006.01)

(76) **Inventor:** **Hoyt A. Fleming, III**, Boise, ID (US)

(52) **U.S. Cl.** **342/20; 342/195; 342/357.31**

Reexamination Request:
No. 90/012,234, Apr. 3, 2012

(58) **Field of Classification Search** None
See application file for complete search history.

Reexamination Certificate for:

Patent No.: **Re. 40,653**
Issued: **Mar. 10, 2009**
Appl. No.: **11/196,841**
Filed: **Aug. 2, 2005**

(56) **References Cited**

Related U.S. Patent Documents

Reissue of:

(64) Patent No.: **6,204,798**
Issued: **Mar. 20, 2001**
Appl. No.: **09/292,089**
Filed: **Apr. 14, 1999**

To view the complete listing of prior art documents cited during the proceeding for Reexamination Control Number 90/012,234, please refer to the USPTO's public Patent Application Information Retrieval (PAIR) system under the Display References tab.

Primary Examiner — Robert Nasser

Related U.S. Application Data

(63) Continuation of application No. 10/352,679, filed on Jan. 28, 2003, now Pat. No. Re. 39,038.

(57) **ABSTRACT**

(51) **Int. Cl.**
G01S 7/36 (2006.01)
G01S 7/42 (2006.01)

A radar detector for alerting an operator of a motor vehicle to an incoming police radar signal. This radar detector includes a microprocessor; a circuit coupled to the microprocessor for detecting the incoming police radar signal; and a global positioning system receiver coupled to the microprocessor. Upon detection of an incoming radar signal, the radar detector can utilize the position, velocity, and/or heading data from the global positioning system receiver to determine whether to generate an alert.

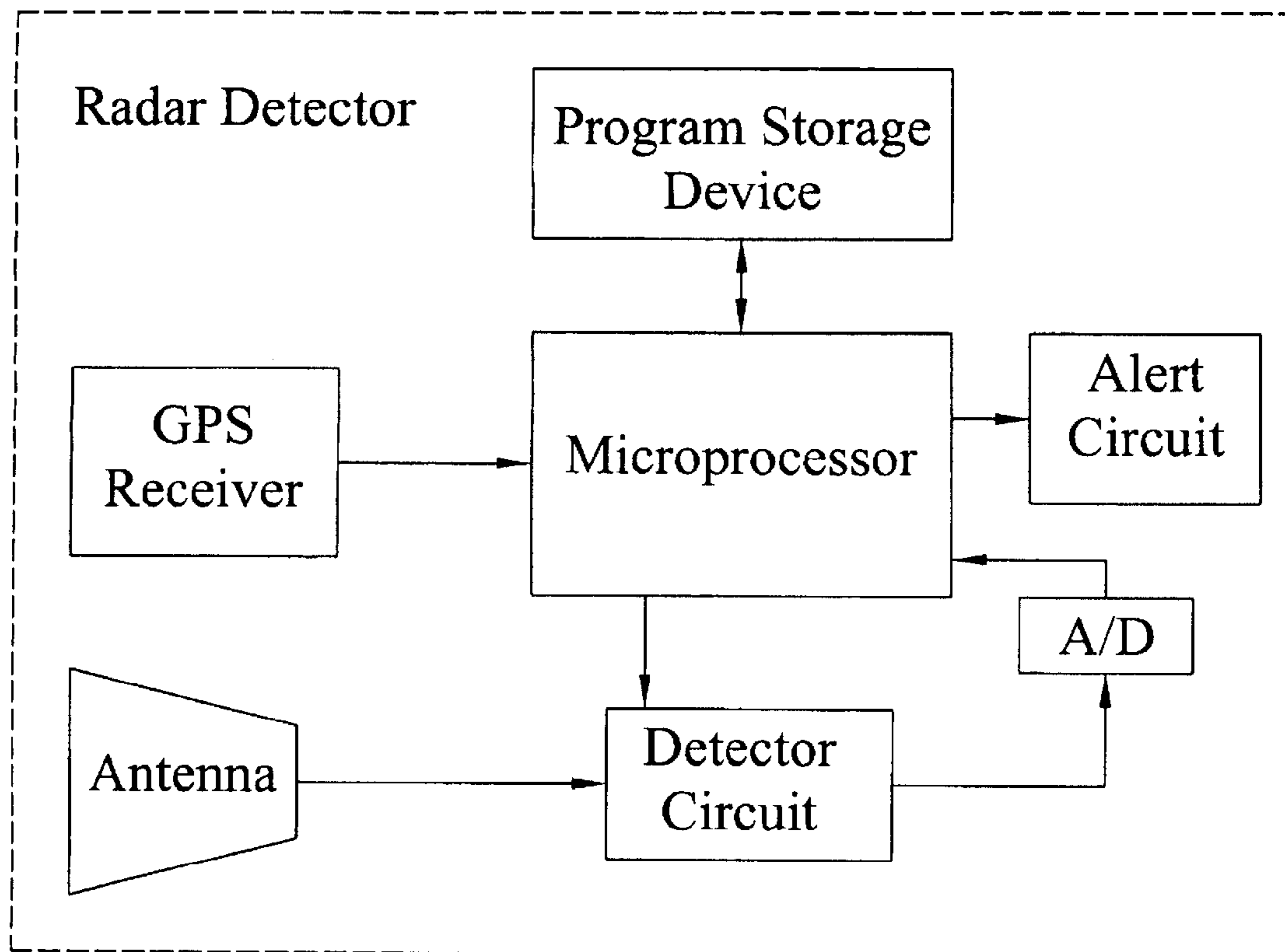

1
EX PARTE
REEXAMINATION CERTIFICATE
ISSUED UNDER 35 U.S.C. 307

NO AMENDMENTS HAVE BEEN MADE TO
THE PATENT

AS A RESULT OF REEXAMINATION, IT HAS BEEN
DETERMINED THAT:

2

The patentability of claims **22-26, 30-33, 38, 41, 42, 45, 46**
and **48-50** is confirmed.

Claims **1-21** were previously cancelled.

5

Claims **27-29, 34-37, 39-40, 43, 44, 47** and **51** were not
reexamined.

* * * * *