

US00RE40625E

(19) **United States**  
(12) **Reissued Patent**  
**Wurz et al.**

(10) **Patent Number:** **US RE40,625 E**  
(45) **Date of Reissued Patent:** **Jan. 27, 2009**

(54) **GAMING MACHINE**

(75) Inventors: **Norman R. Wurz**, Des Plaines, IL (US);  
**James M. Rasmussen**, Chicago, IL  
(US); **William C. Cesaroni**, Glenview,  
IL (US); **Robert J. Glenn, III**, Elk  
Grove Village, IL (US); **Jack B. Hough**,  
Arlington Heights, IL (US)

(73) Assignee: **WMS Gaming Inc.**, Waukegan, IL (US)

(21) Appl. No.: **29/236,160**

(22) Filed: **Aug. 11, 2005**

**Related U.S. Patent Documents**

Reissue of:

(64) Patent No.: **D. 459,402**  
Issued: **Jun. 25, 2002**  
Appl. No.: **29/147,267**  
Filed: **Aug. 24, 2001**

U.S. Applications:

(60) Division of application No. 29/193,474, filed on Jul. 28,  
2003, which is a continuation-in-part of application No.  
09/441,125, filed on Nov. 17, 1999, now Pat. No. 6,334,612.

(51) **LOC (9) Cl.** ..... **21-01**

(52) **U.S. Cl.** ..... **D21/325; D21/369**

(58) **Field of Classification Search** ..... D21/324–327,  
D21/333, 369, 370, 371; 463/1, 2, 13, 18,  
463/19, 20, 46, 47, 29–35, 50–52; 273/148 B,  
273/143 R; 482/901, 902; 343/3, 4  
See application file for complete search history.

(56) **References Cited**

**U.S. PATENT DOCUMENTS**

D333,164 S \* 2/1993 Kraft et al. .... D21/325  
5,411,257 A 5/1995 Fulton ..... 273/85  
5,820,460 A \* 10/1998 Fulton ..... 463/13  
D419,606 S 1/2000 Toriyama ..... D21/325

(Continued)

*Primary Examiner—Prabhakar Deshmukh*  
(74) *Attorney, Agent, or Firm—Nixon Peabody LLP*

(57) **CLAIM**

The ornamental design for a “gaming machine”, as shown  
and described.

**DESCRIPTION**

FIG. 1 is an isometric view of a gaming machine showing  
our new design.

FIG. 2 is a front elevational view thereof.

FIG. 3 is a rear elevational view thereof.

FIG. 4 is a left side elevational view thereof.

FIG. 5 is a right side elevational view thereof.

FIG. 6 is a top plan view thereof [; and,].

FIG. 7 is a bottom plan view thereof.

*FIG. 8 is an isometric view of a gaming machine according  
to an alternative embodiment of our new design.*

*FIG. 9 is a front elevational view of the gaming machine of  
FIG. 8.*

*FIG. 10 is a rear elevational view of the gaming machine of  
FIG. 8.*

*FIG. 11 is a left side elevational view of the gaming machine  
of FIG. 8.*

*FIG. 12 is a right side elevational view of the gaming  
machine of FIG. 8.*

*FIG. 13 is a top plan view of the gaming machine of FIG. 8;  
and,*

*FIG. 14 is a bottom plan view of the gaming machine of FIG.  
8.*

The broken lines shown *immediately adjacent the shaded  
areas represent the bounds of the claimed design while all  
other broken lines are for illustrative purposes only [and];  
the broken lines form no part of the claimed design.*

**1 Claim, 8 Drawing Sheets**

**Matter enclosed in heavy brackets [ ] appears in the  
original patent, but forms no part of this reissue; matter  
printed in italics indicates the additions made by reissue.**

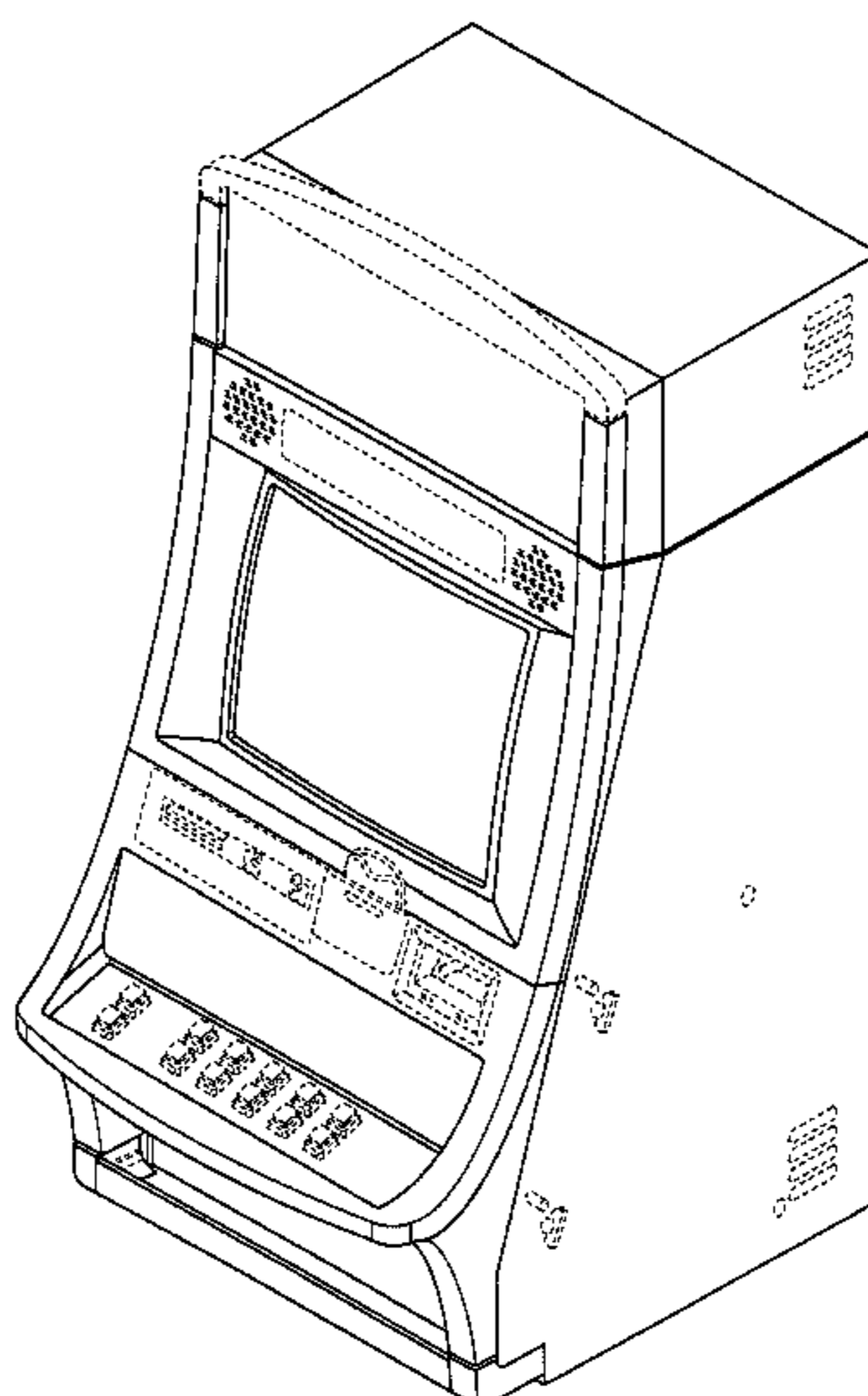

# US RE40,625 E

Page 2

---

U.S. PATENT DOCUMENTS			
D428,062 S	7/2000	Hayashi .....	D21/325
D439,931 S *	4/2001	Yamaguchi .....	D21/369
6,210,279 B1 *	4/2001	Dickinson .....	463/37
D446,252 S	8/2001	Yamaguchi .....	D21/325
6,290,229 B1	9/2001	Perez .....	273/148
6,616,142 B2 *	9/2003	Adams .....	273/292
D495,755 S *	9/2004	Wurz et al. ....	D21/370

\* cited by examiner

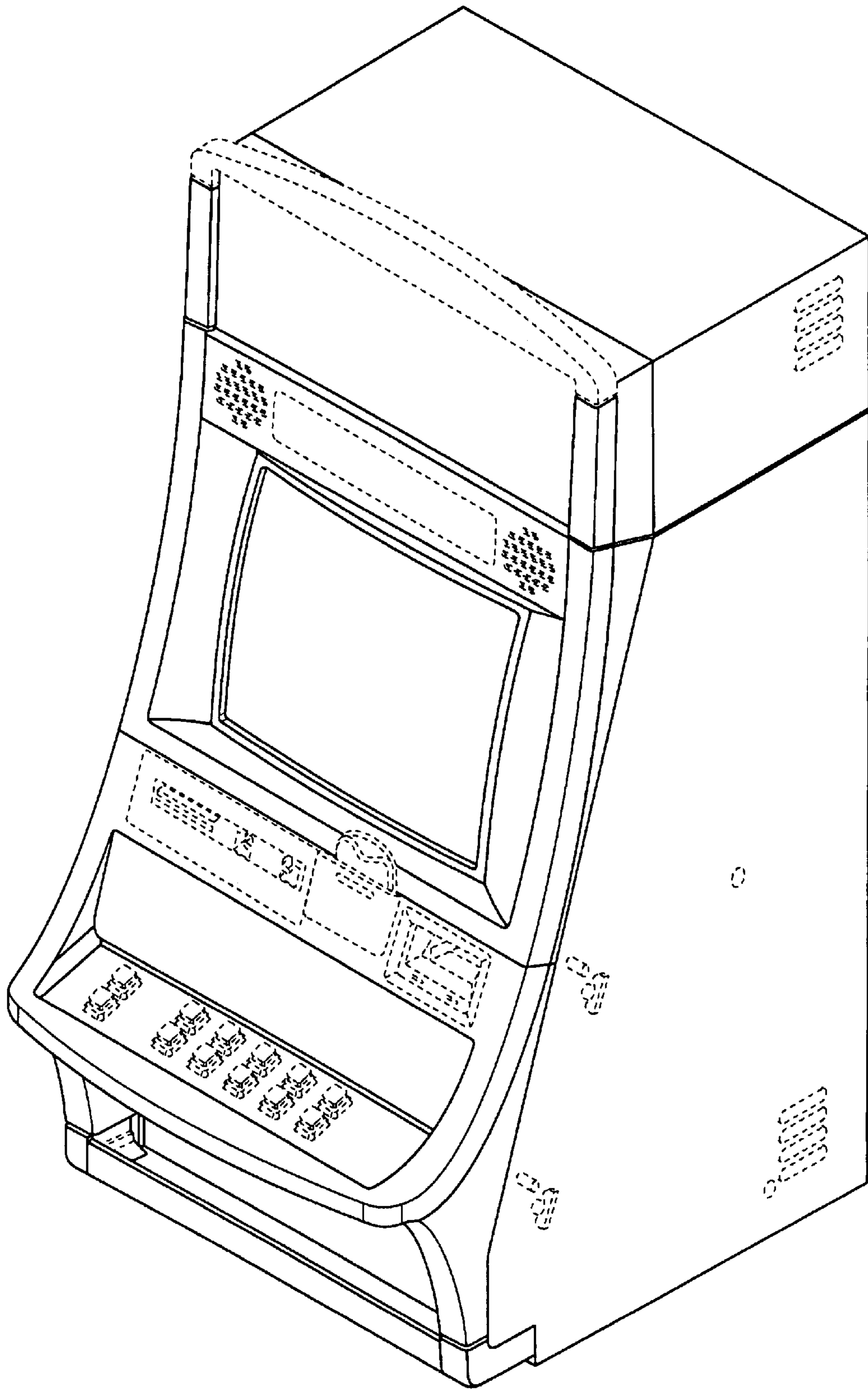

FIG. 1

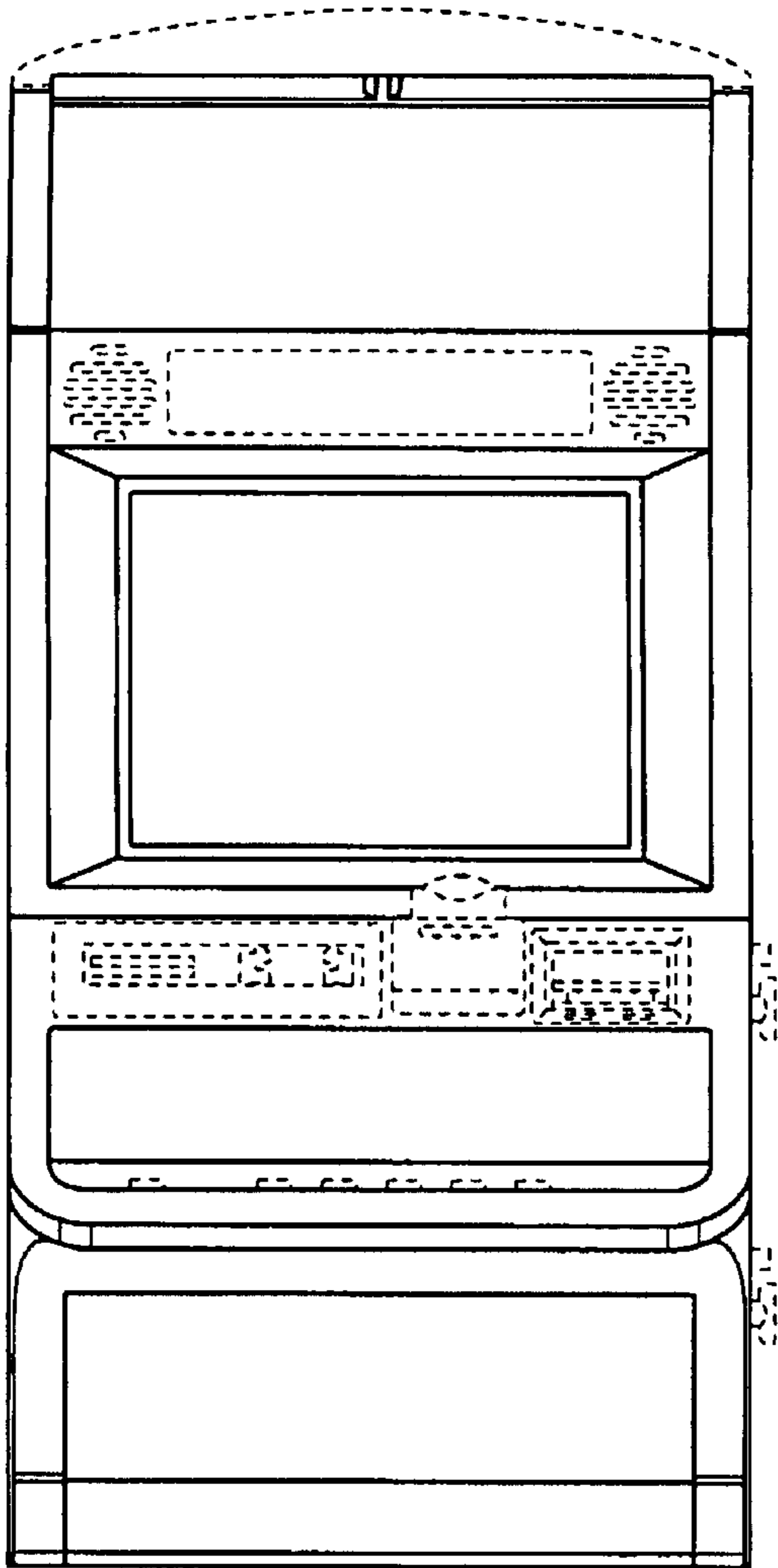

FIG. 2

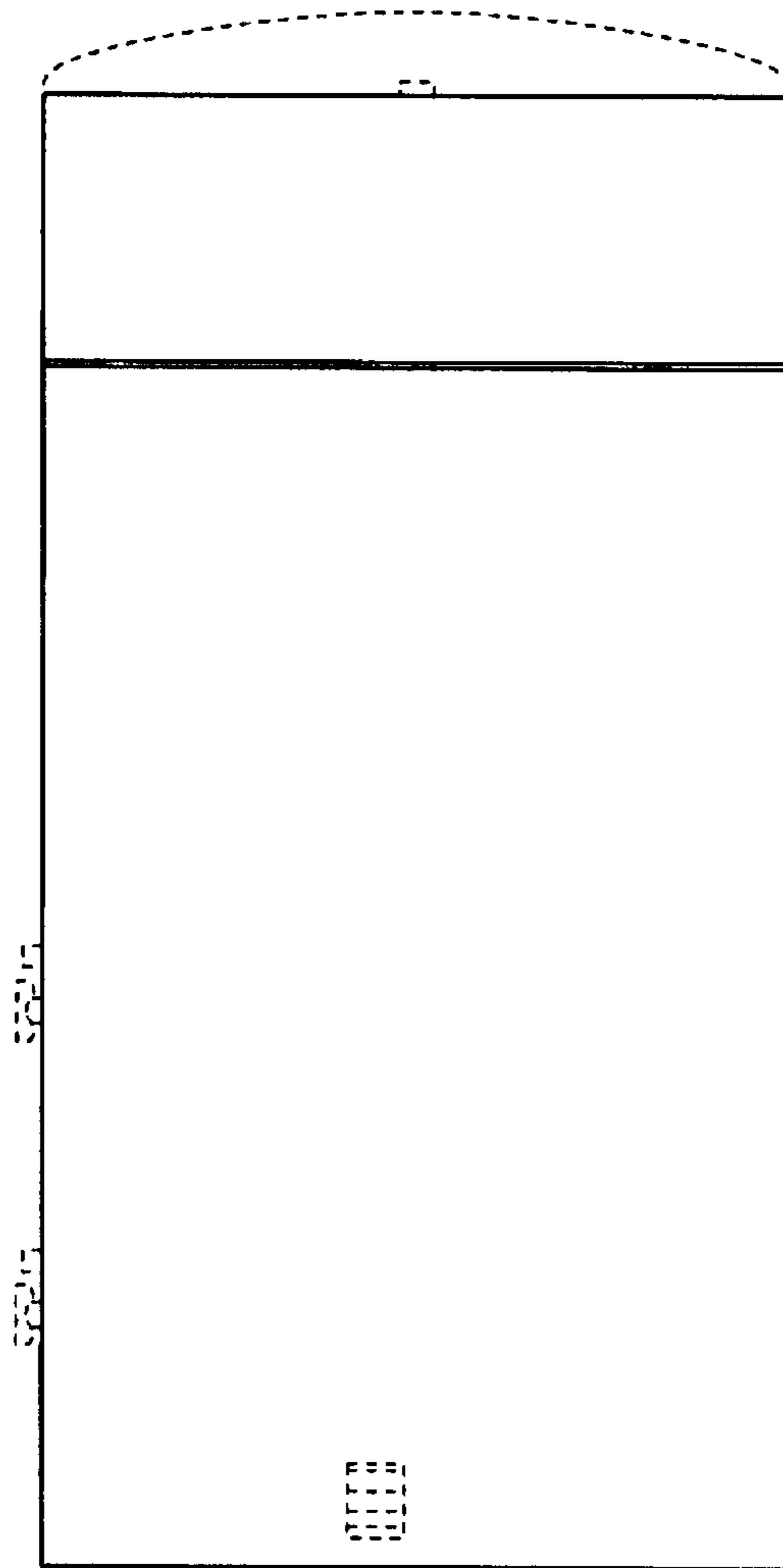

FIG. 3

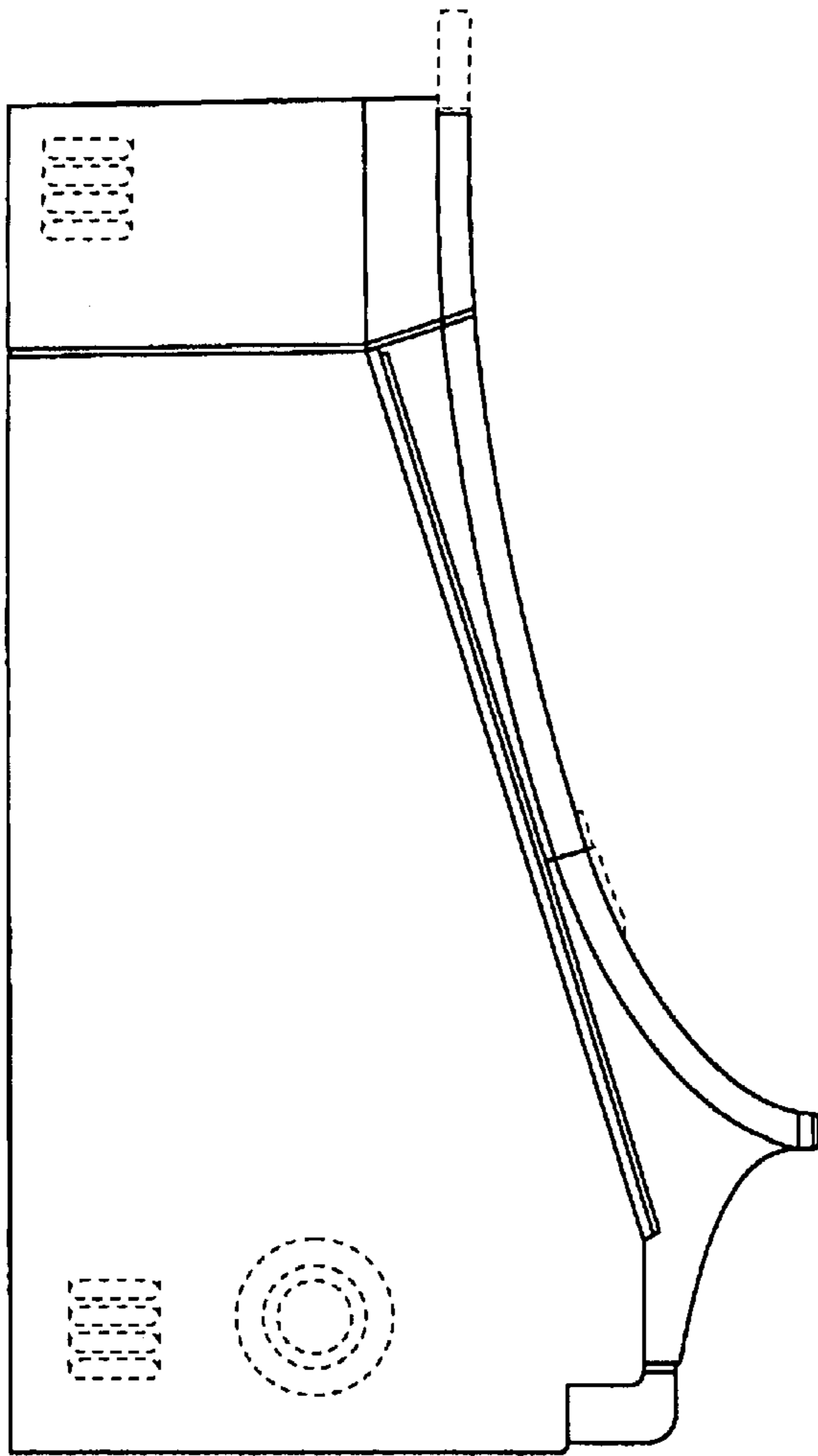

FIG. 4

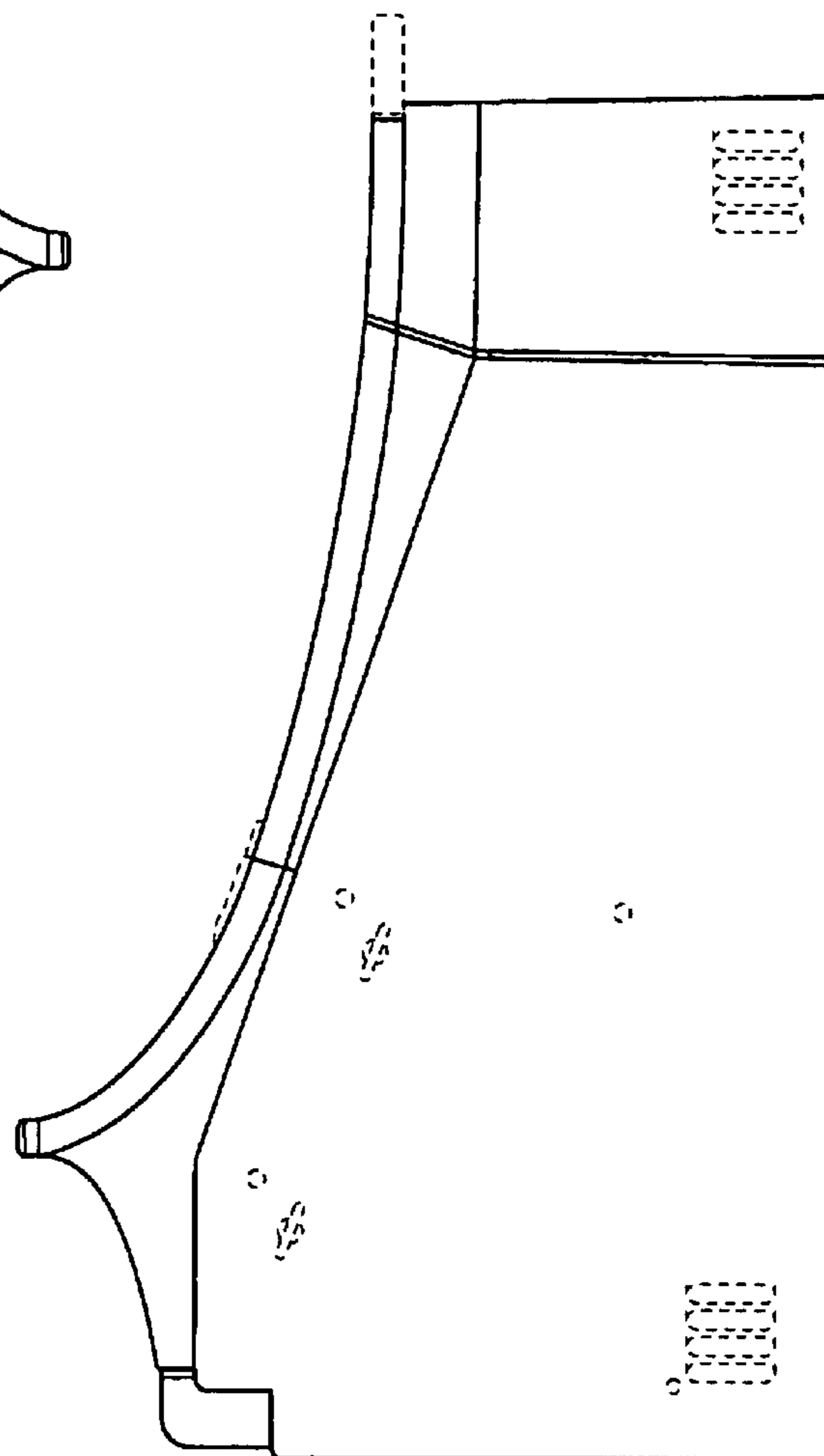

FIG. 5

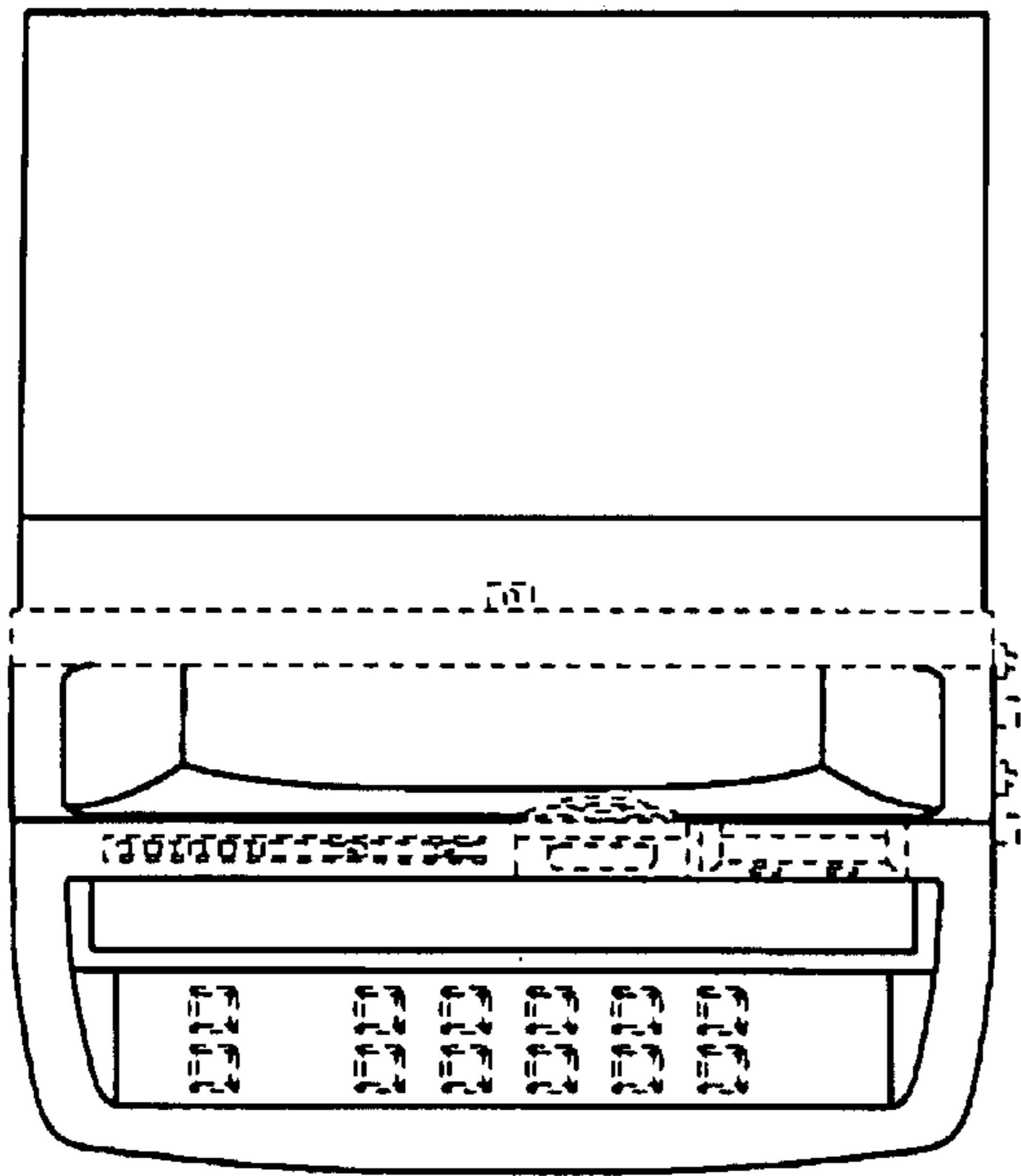

FIG. 6

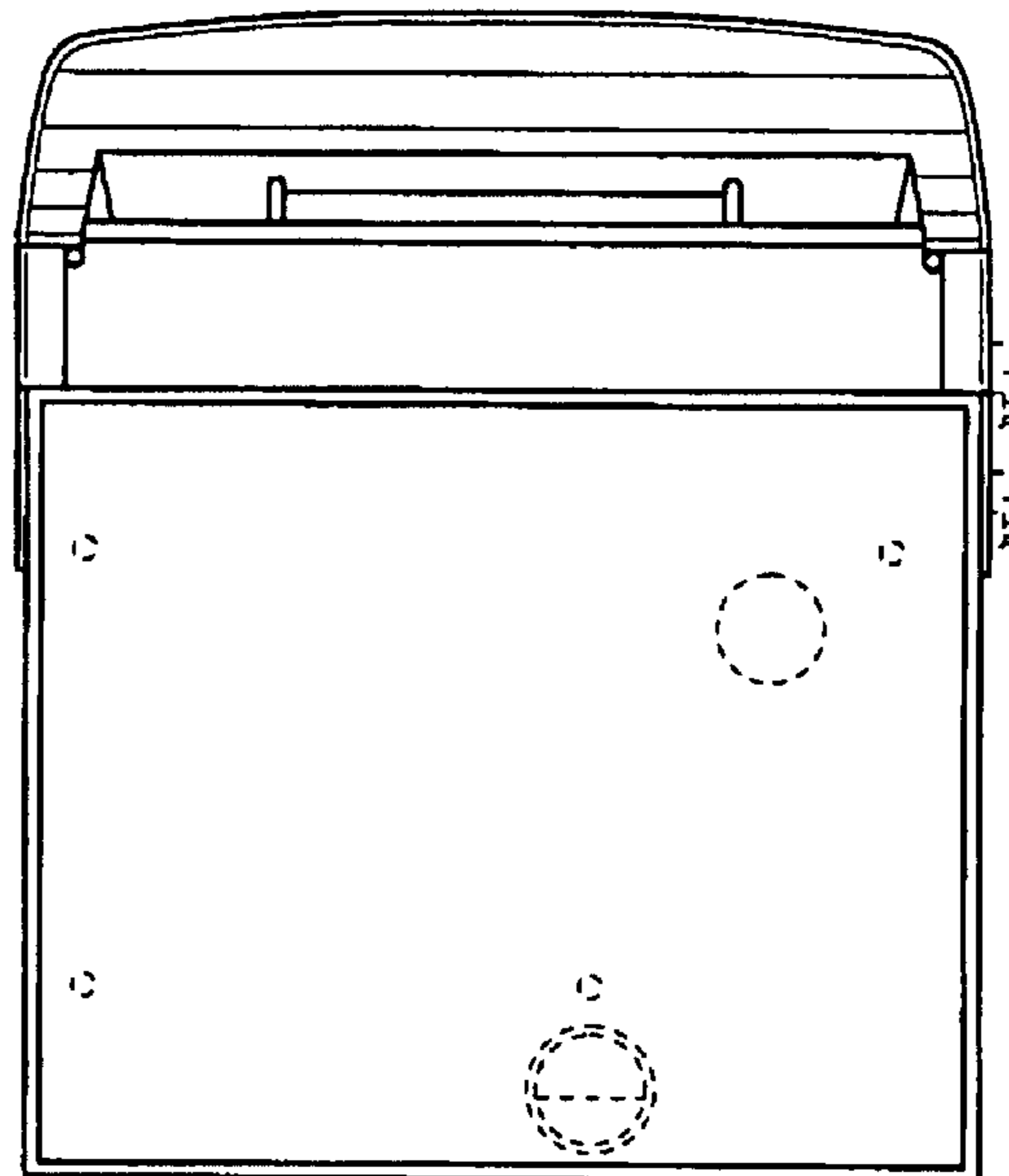

FIG. 7

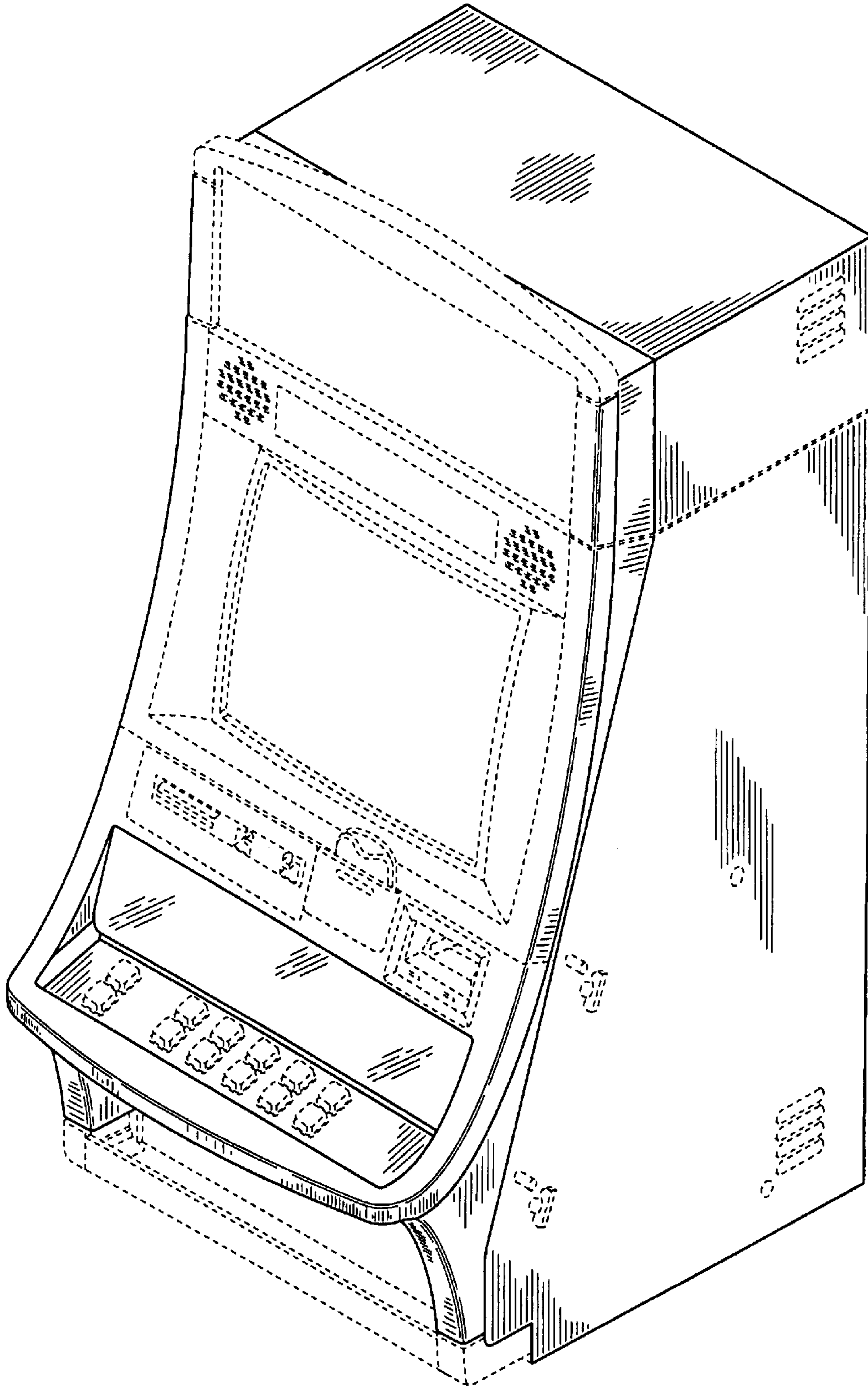

FIG. 8

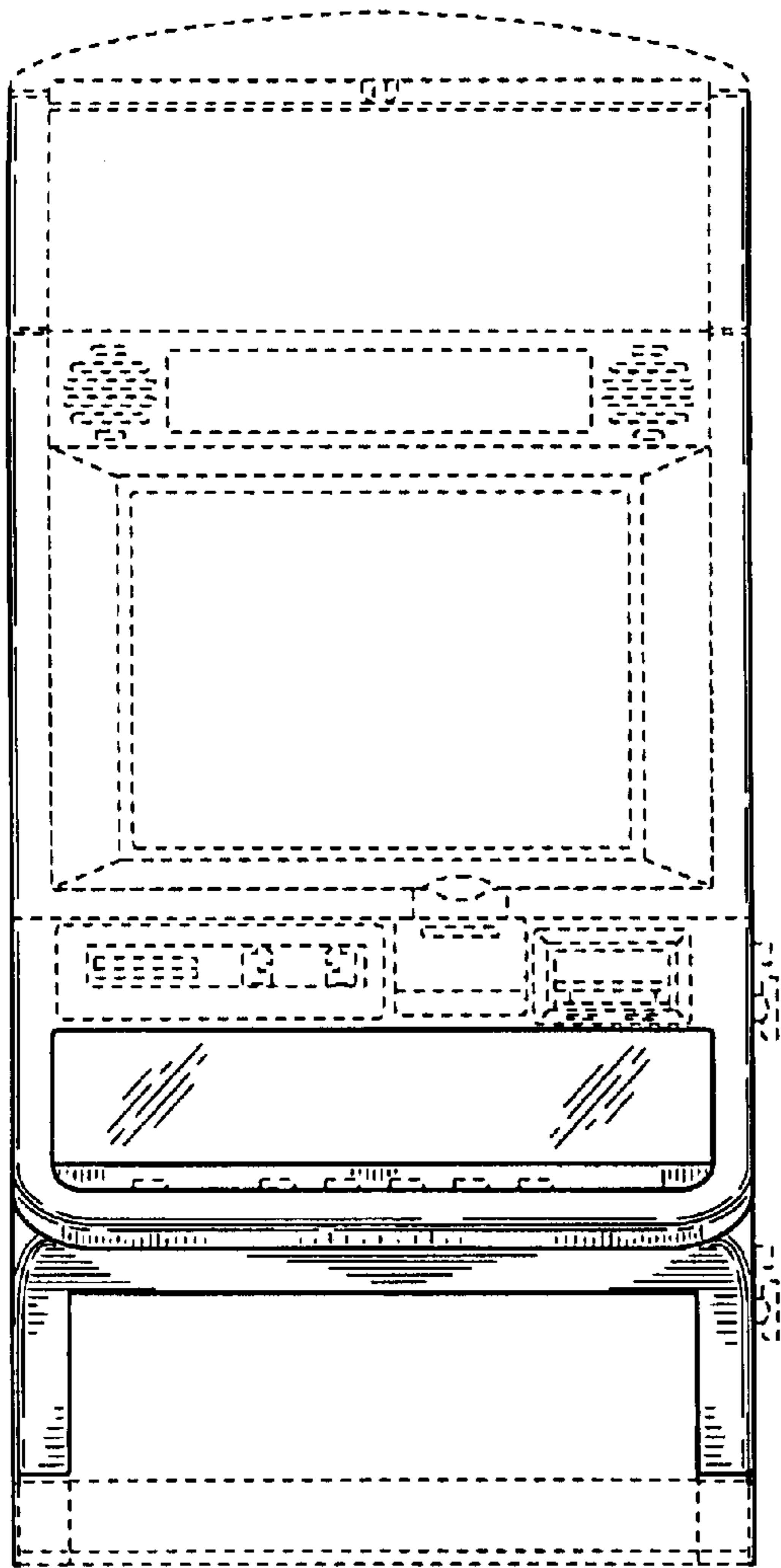

FIG. 9

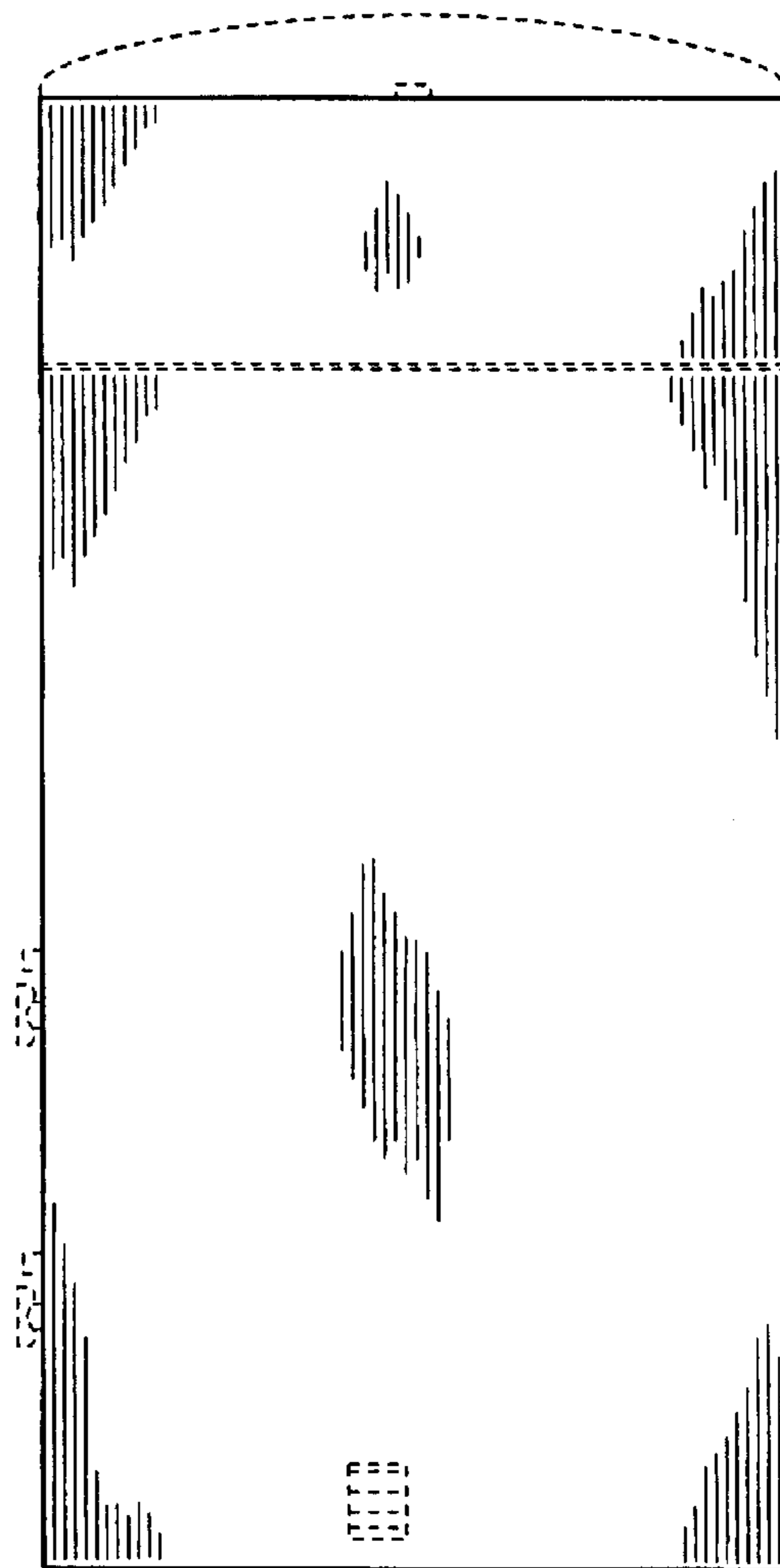

FIG. 10



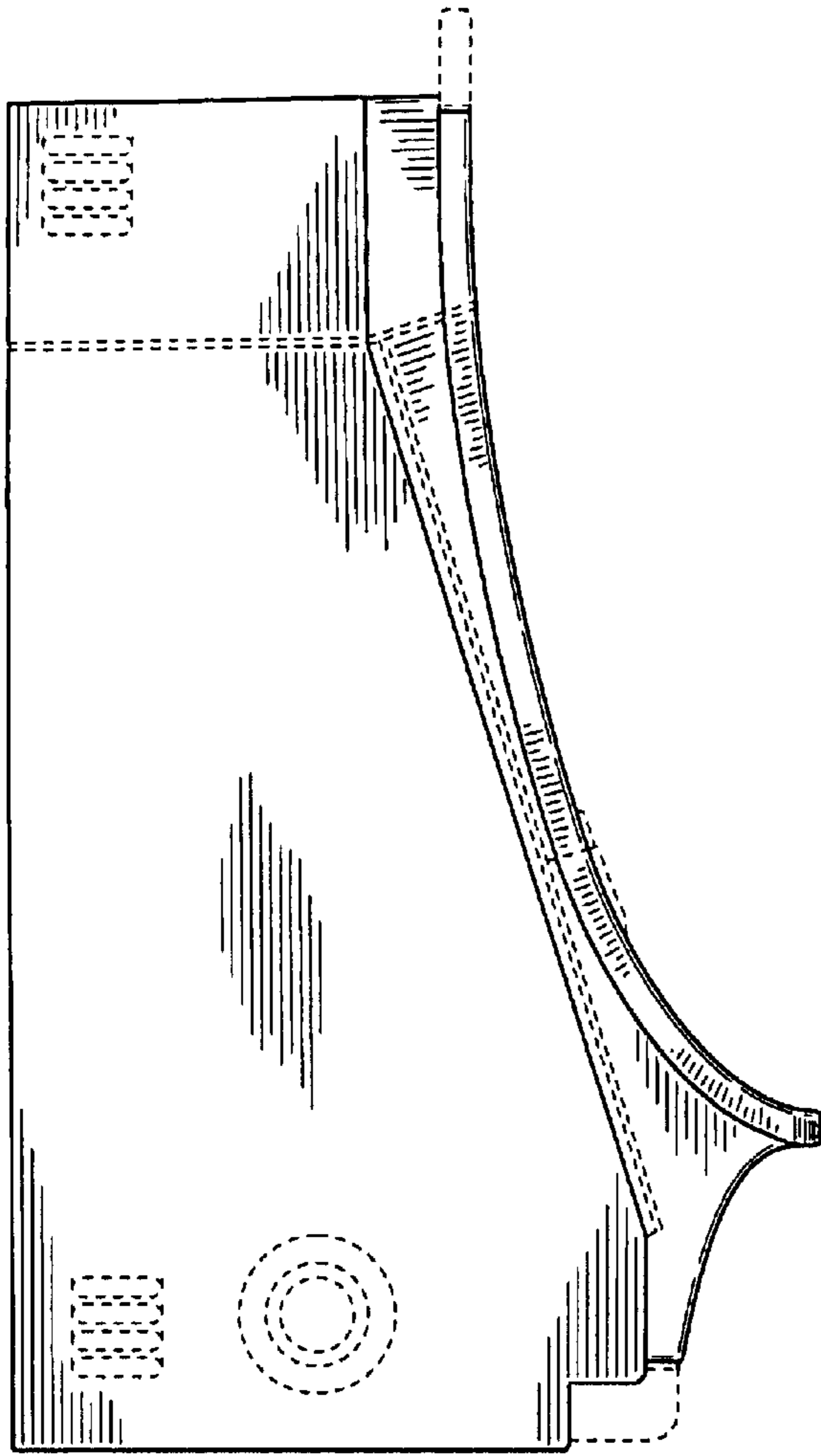

FIG. 11

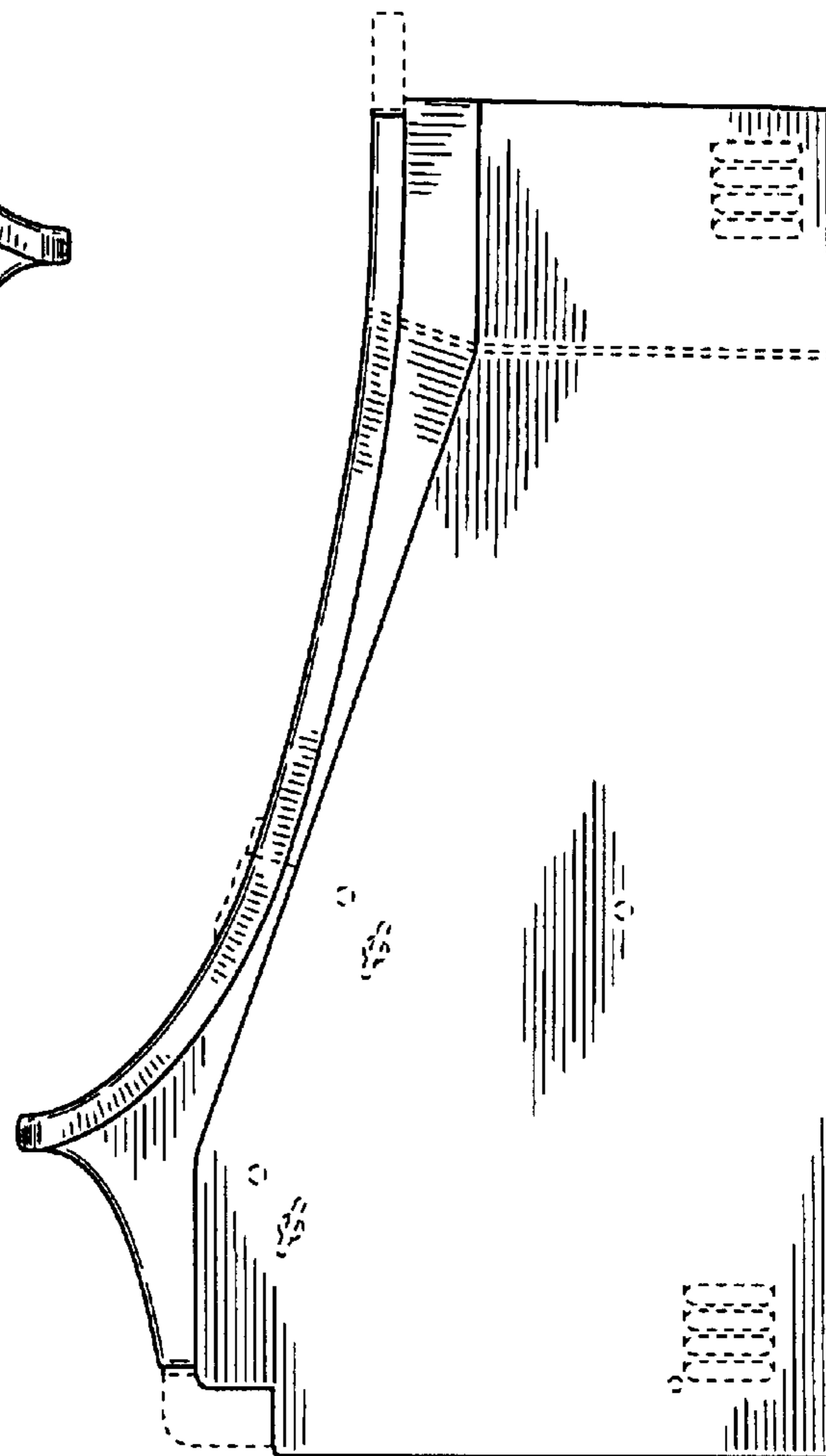

FIG. 12

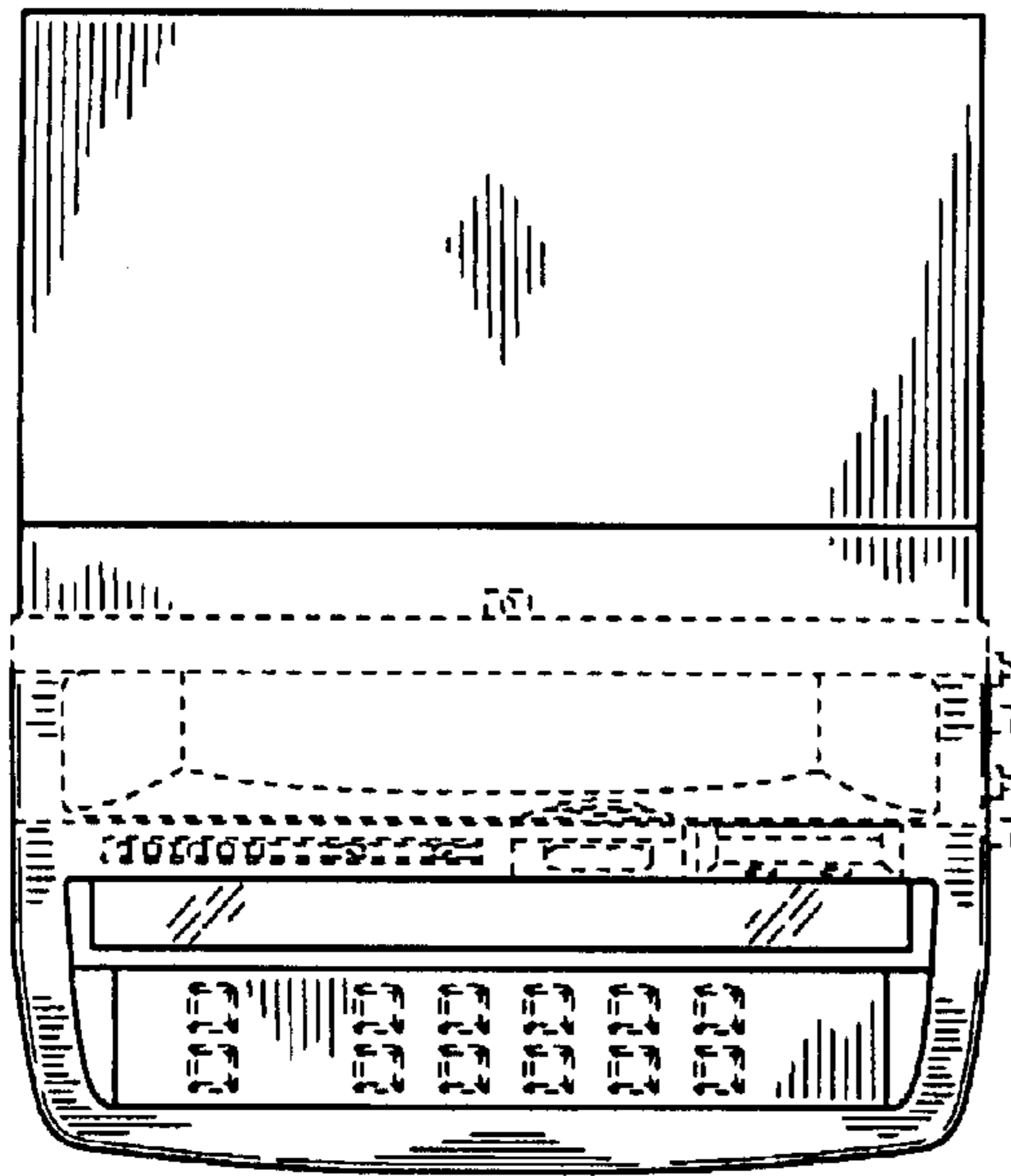

FIG. 13

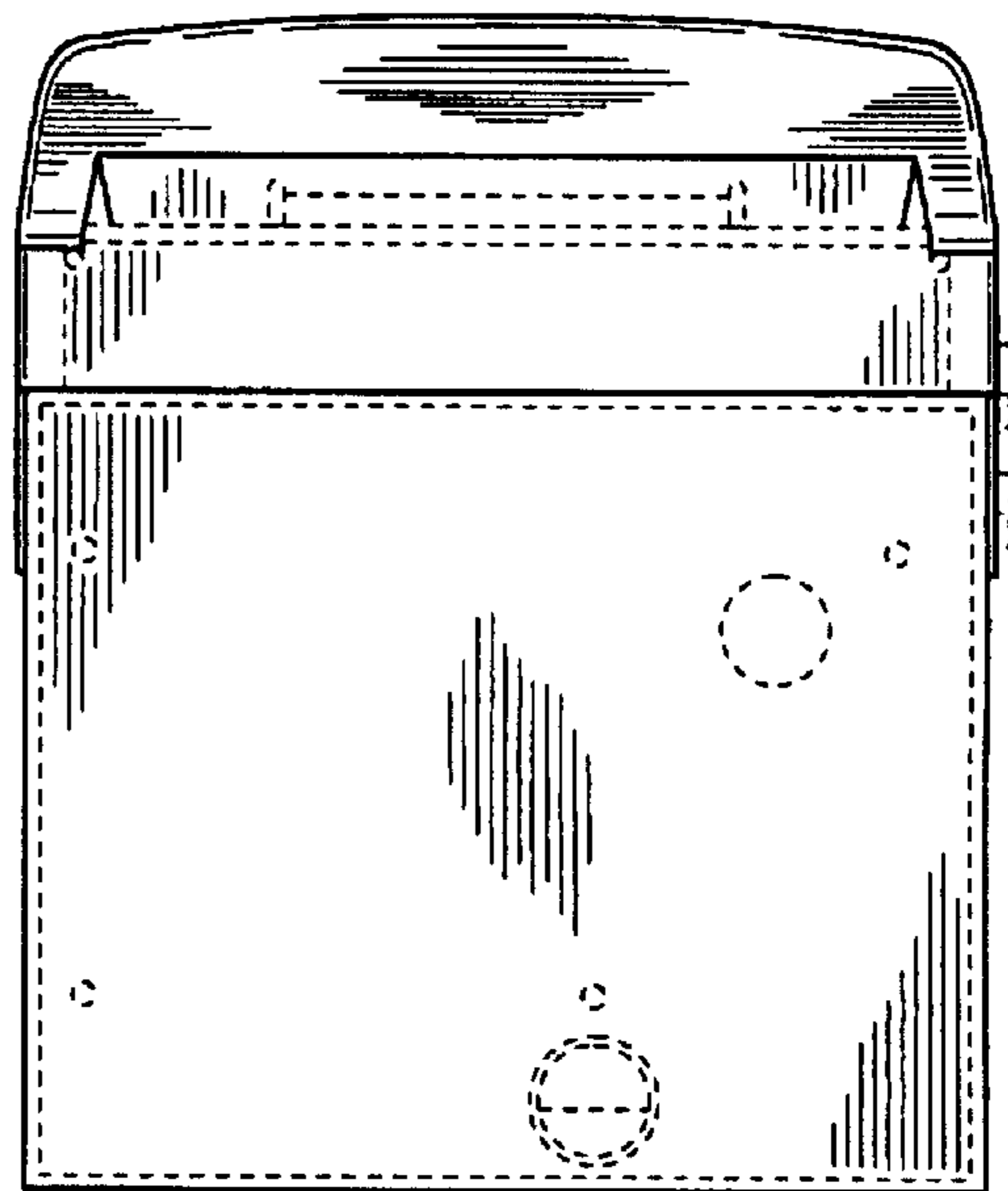

FIG. 14