

US00RE40598E

(19) **United States**  
(12) **Reissued Patent**  
**Russ**

(10) **Patent Number:** **US RE40,598 E**  
(45) **Date of Reissued Patent:** **Dec. 2, 2008**

(54) **MEMORY STORAGE DISK HANDLING SYSTEM HAVING A SERVO-DRIVEN ELEVATOR PIN**

FOREIGN PATENT DOCUMENTS

(75) Inventor: **Wray Russ**, Modesto, CA (US)

(73) Assignee: **Microboards Technology, LLC**, Chanhassen, MN (US)

(21) Appl. No.: **11/322,203**

(22) Filed: **Dec. 28, 2005**

**Related U.S. Patent Documents**

Reissue of:

(64) Patent No.: **6,782,544**  
Issued: **Aug. 24, 2004**  
Appl. No.: **09/828,569**  
Filed: **Apr. 5, 2001**

U.S. Applications:

(63) Continuation-in-part of application No. 09/088,652, filed on Jun. 1, 1998, now Pat. No. 6,337,842.

(51) **Int. Cl.**  
**G11B 17/08** (2006.01)  
**B65G 57/30** (2006.01)

(52) **U.S. Cl.** ..... **720/619**; 414/795.3; 414/794.9; 369/30.34; 369/30.55; 369/30.57; 369/30.6

(58) **Field of Classification Search** ..... 101/35, 101/36, 37, 43, 44; 414/797.4, 797.9, 798.1, 414/795.3, 794.9; 221/254, 258, 289, 290, 221/296, DIG. 1; 369/30.34, 30.55, 30.57, 369/30.6; 360/92; 720/619; 719/619

See application file for complete search history.

(56) **References Cited**

U.S. PATENT DOCUMENTS

1,058,144 A 4/1913 Blank  
2,296,013 A 9/1942 Bell

(Continued)

EP	448247	A2	9/1991
EP	448247		9/1991
GB	584924	A	1/1947
GB	597777	A	2/1948
GB	910949	A	11/1962
GB	2305659	A *	4/1997
JP	55087343		7/1980
JP	61180983		8/1986
JP	01011522	A *	1/1989
JP	04152491	A *	5/1992
JP	06020374		1/1994
JP	06020374	A	1/1994
JP	07153219	A	6/1995
JP	07153219		6/1995
JP	09188418	A *	7/1997
RU	1633453	A	3/1991
SU	1633453		3/1991

OTHER PUBLICATIONS

“Automatic Disk Stacking Devices”, IBM TDB, 21(6): 2499–2502, 1978.

“Mechanism and Method for Diskette Insertion”, IBM TDB 28(10): 4431–4435, 1986.

Emedia Professional “Buyers Guide to CD Duplication Systems—40 New towers, autoloaders, jukeboxes”, 1997.

Matusiak, “Buffalo State College Department of Technology Engineering Instructional Support” [on-line] [retrieved May 5, 2005] retrieved from the Internet <URL:http://facstaff.buffalostate.edu/matusirc/public-html/index.html>, 12 pgs.

*Primary Examiner*—William J Klimowicz

(74) *Attorney, Agent, or Firm*—Fish & Richardson P.C.

(57) **ABSTRACT**

A memory storage disk handling system includes a housing, an elevator pin mounted on the housing for lifting disks, a servo motor with a cam arm. The servo motor rotates to pivot the cam arm, which cams against the elevator pin to lift the elevator pin.

**58 Claims, 29 Drawing Sheets**

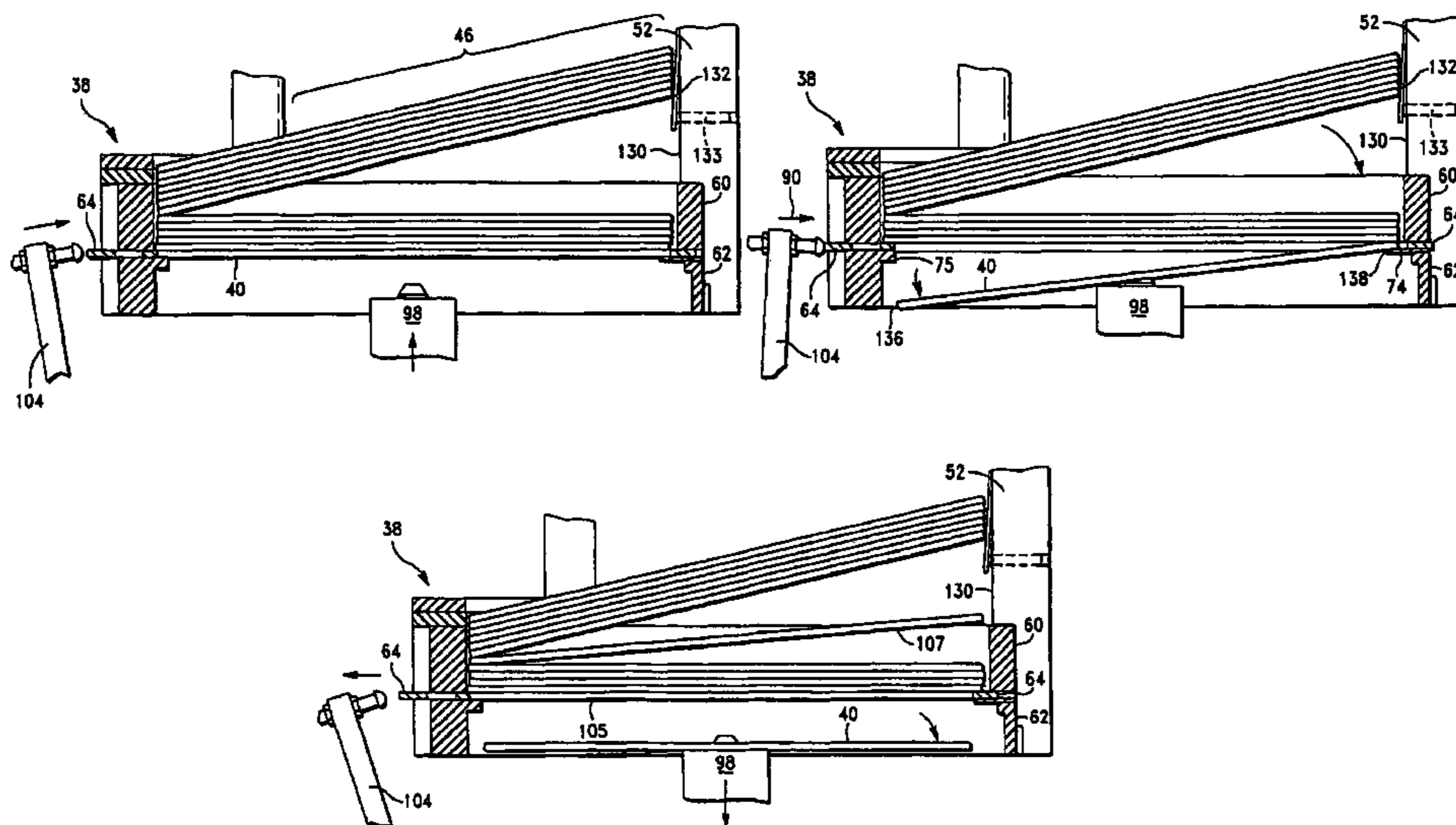

# US RE40,598 E

Page 2

U.S. PATENT DOCUMENTS					
2,304,437	A	12/1942 Bell	5,583,839	A	12/1996 Choi
2,328,703	A	9/1943 Becwar	5,636,199	A	6/1997 Ariyoshi et al.
2,504,596	A	4/1950 Scriven et al.	5,692,878	A	12/1997 Freund
2,960,340	A	11/1960 Seidel et al.	5,721,715	A	2/1998 Mitani et al.
3,253,832	A	5/1966 Tatter et al.	5,734,629	A	3/1998 Lee et al.
3,288,471	A	11/1966 Weedfall	5,822,162	A	10/1998 Tannert
3,709,504	A	1/1973 Sherwood	5,842,598	A	* 12/1998 Tsuchida ..... 221/258
3,892,415	A	7/1975 Takahashi et al.	5,846,005	A	12/1998 Britz et al.
4,168,069	A	9/1979 Cukrowski	5,857,710	A	1/1999 Leising et al.
4,195,961	A	4/1980 Waiblinger	5,865,114	A	2/1999 Averill et al.
4,278,258	A	7/1981 Fujita et al.	5,888,433	A	3/1999 Amo
4,413,750	A	* 11/1983 Morrone et al. .... 221/263	5,912,680	A	6/1999 Uchida et al.
4,417,757	A	11/1983 Morrison	5,914,918	A	6/1999 Lee et al.
4,470,137	A	9/1984 Tago	5,927,208	A	7/1999 Hagstrom et al.
4,504,186	A	3/1985 Richards	5,934,865	A	8/1999 Meadows
4,559,623	A	12/1985 Dennis	5,957,198	A	9/1999 Haynes
4,594,042	A	6/1986 Hoffman	5,975,839	A	11/1999 Ashby
4,595,481	A	6/1986 Allen et al.	5,984,295	A	11/1999 Britz
4,646,178	A	* 2/1987 Garratt et al. .... 360/98.06	6,024,532	A	* 2/2000 Ashby ..... 414/798.1
4,677,508	A	6/1987 Barton, Jr. et al.	6,075,758	A	6/2000 Wu
4,701,896	A	10/1987 Allebest et al.	6,097,693	A	8/2000 Nakamichi
4,726,615	A	2/1988 Goldberg	6,111,847	A	8/2000 Assadian
4,735,540	A	4/1988 Allen et al.	6,113,345	A	9/2000 Ashby
4,810,153	A	3/1989 Armelin	6,123,020	A	9/2000 Wolfer et al.
4,830,375	A	* 5/1989 Fleming ..... 273/148 R	6,134,213	A	10/2000 Suzuki et al.
4,921,397	A	5/1990 Watanabe	6,135,316	A	10/2000 Wolfer et al.
5,050,023	A	9/1991 Ashby	6,147,960	A	11/2000 Wolfer et al.
5,050,852	A	* 9/1991 Sawada et al. .... 271/11	6,148,722	A	11/2000 Hagstrom
5,067,702	A	11/1991 Muraishi et al.	6,213,457	B1	4/2001 Schlough
5,099,466	A	3/1992 Kimura et al.	6,215,757	B1	4/2001 Fujimoto et al.
5,110,167	A	5/1992 Friend	6,222,800	B1	4/2001 Miller et al.
5,123,005	A	6/1992 Kurosu	6,246,655	B1	6/2001 Miller
5,130,959	A	7/1992 Wakatsuki et al.	6,302,601	B1	10/2001 Hagstrom et al.
5,210,729	A	5/1993 Schmidt et al.	6,332,680	B1	12/2001 Ozawa
5,218,375	A	6/1993 Hillman	6,337,842	B1	1/2002 Wolfer et al.
5,317,337	A	5/1994 Ewaldt	6,354,502	B1	3/2002 Hagstrom et al.
5,322,188	A	6/1994 Dodaro	6,447,181	B1	9/2002 Hagstrom et al.
5,370,495	A	* 12/1994 Montalvo et al. .... 414/797.9	6,474,805	B2	11/2002 Dante et al.
5,383,573	A	* 1/1995 Balsimo ..... 221/264	6,499,841	B1	12/2002 Uchida et al.
5,397,214	A	3/1995 Cheung	6,760,052	B2	7/2004 Cummins et al.
5,415,519	A	5/1995 Lee et al.	6,782,544	B2	8/2004 Russ
5,482,428	A	* 1/1996 Kuhlman ..... 414/798.1	6,793,302	B2	9/2004 Russ
5,490,020	A	2/1996 Albrecht et al.	6,887,313	B2	5/2005 Russ
5,505,509	A	4/1996 Vance	7,032,232	B2	4/2006 Russ
5,518,361	A	5/1996 Smith	7,063,746	B2	6/2006 Russ
5,520,106	A	5/1996 Karlyn et al.	2002/0021921	A1	2/2002 Akema et al.
5,520,107	A	5/1996 Airoidi	2002/0092735	A1	7/2002 Greive et al.
5,537,376	A	7/1996 Ikuma	2003/0002400	A1	1/2003 Klein
5,549,444	A	8/1996 Dubuit			

\* cited by examiner

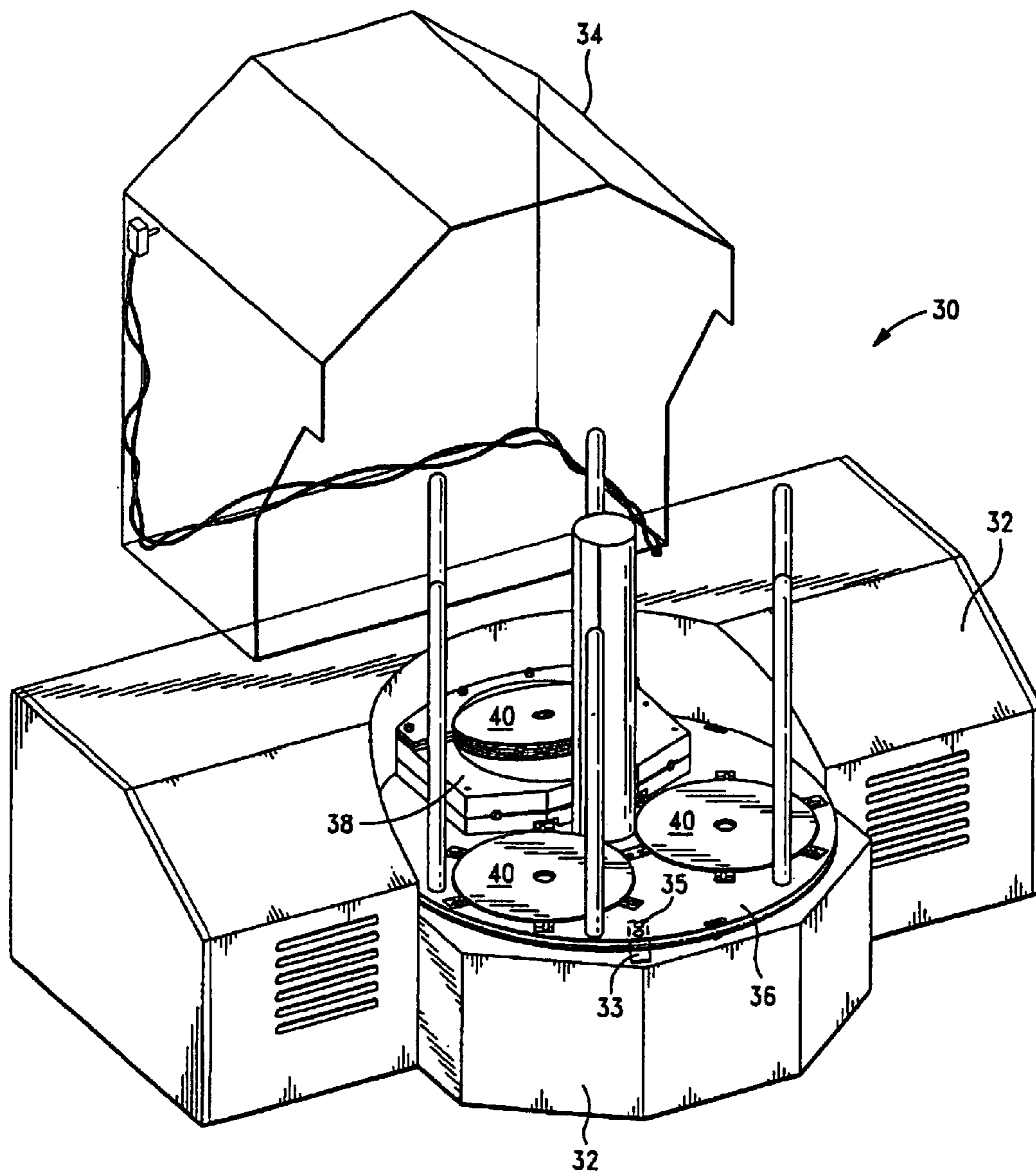

FIG.-1

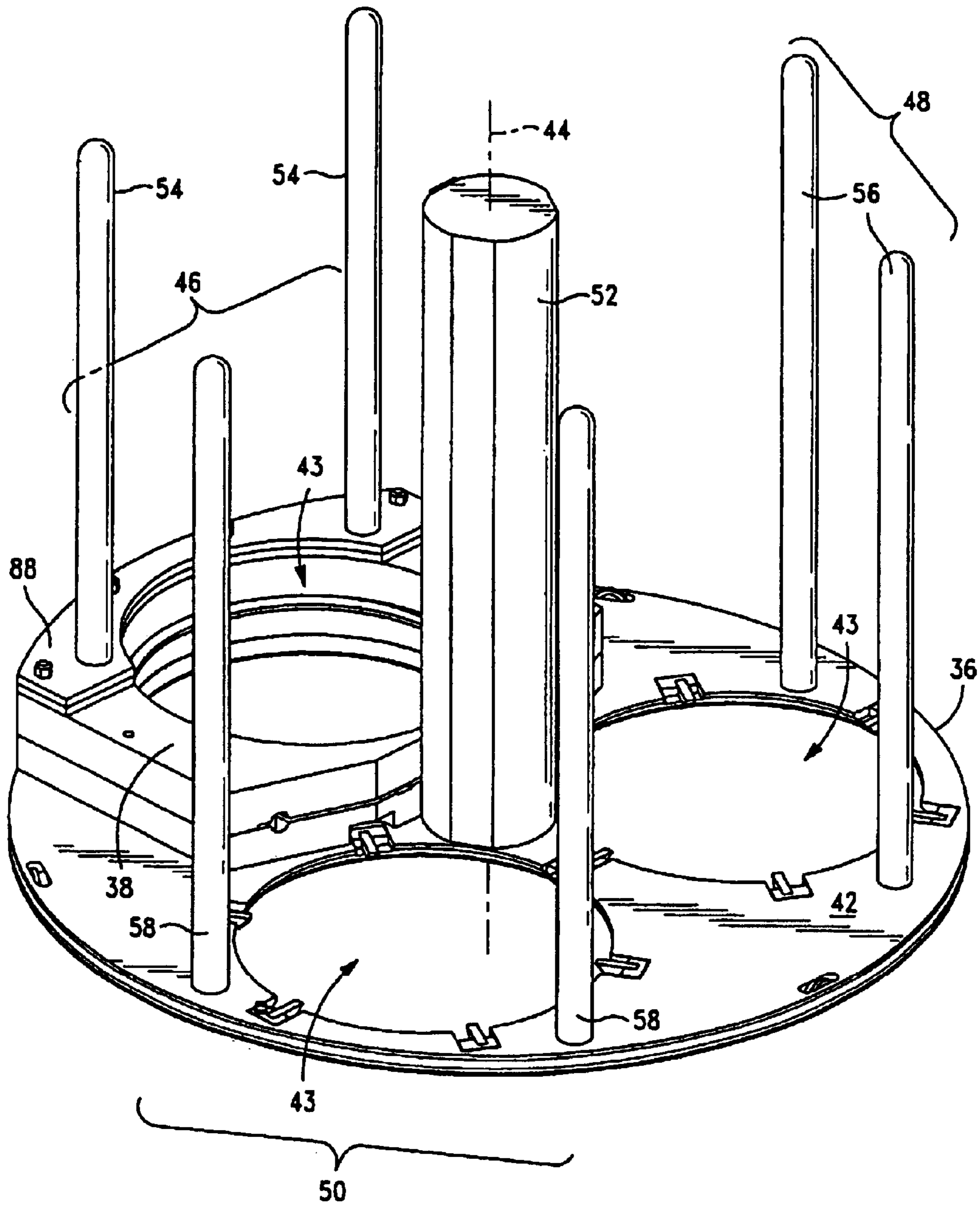

FIG.-2



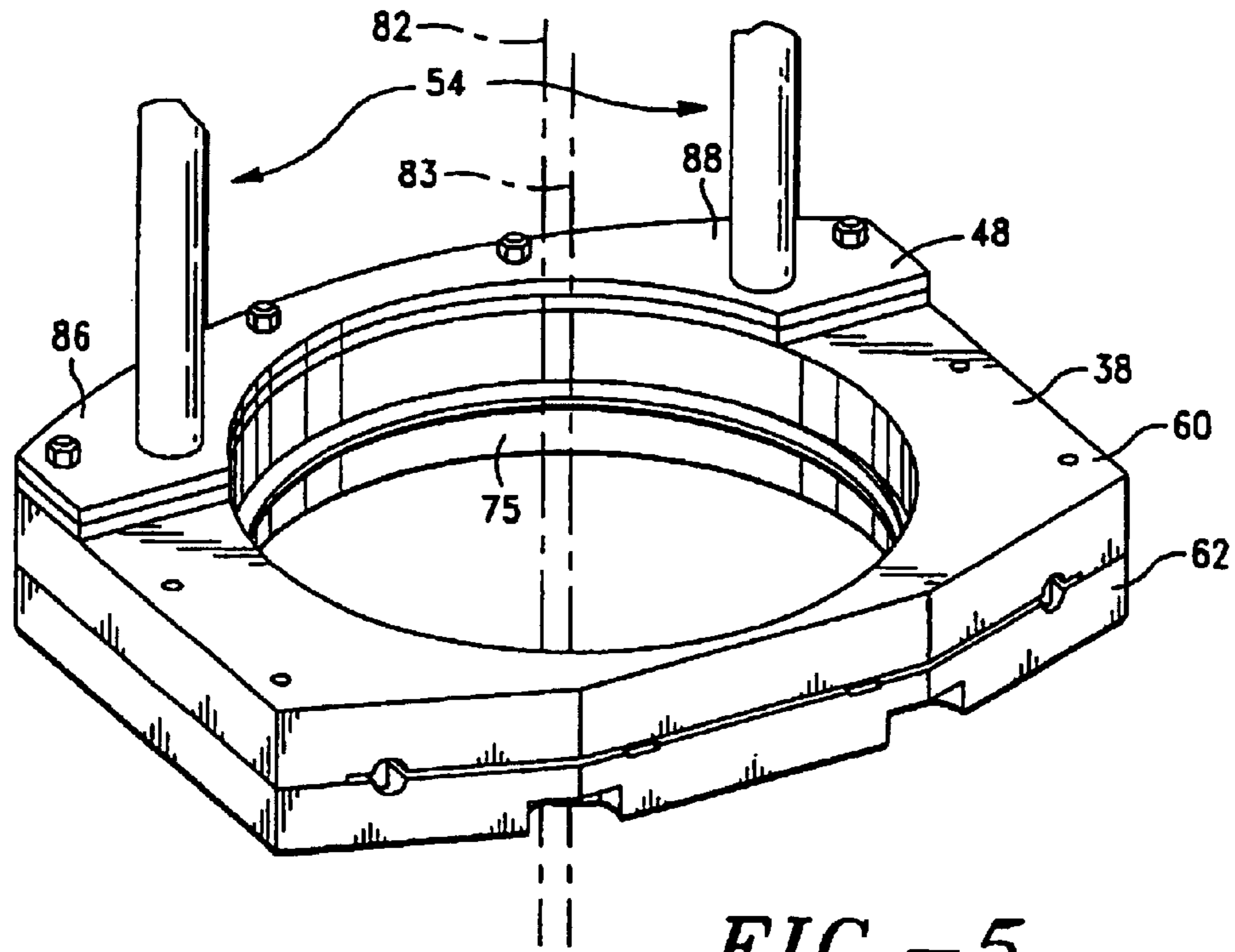

FIG.-5

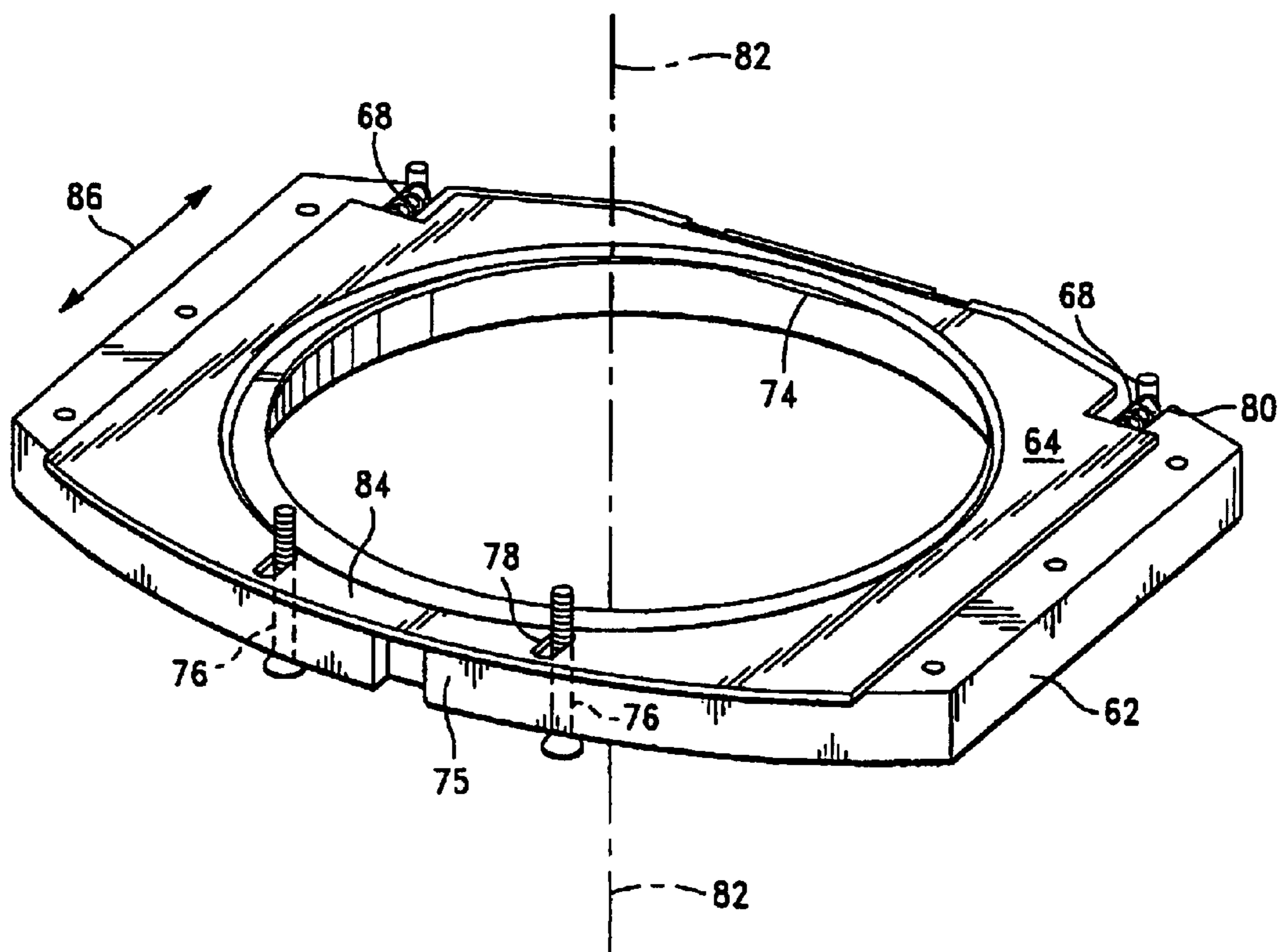

FIG.-4

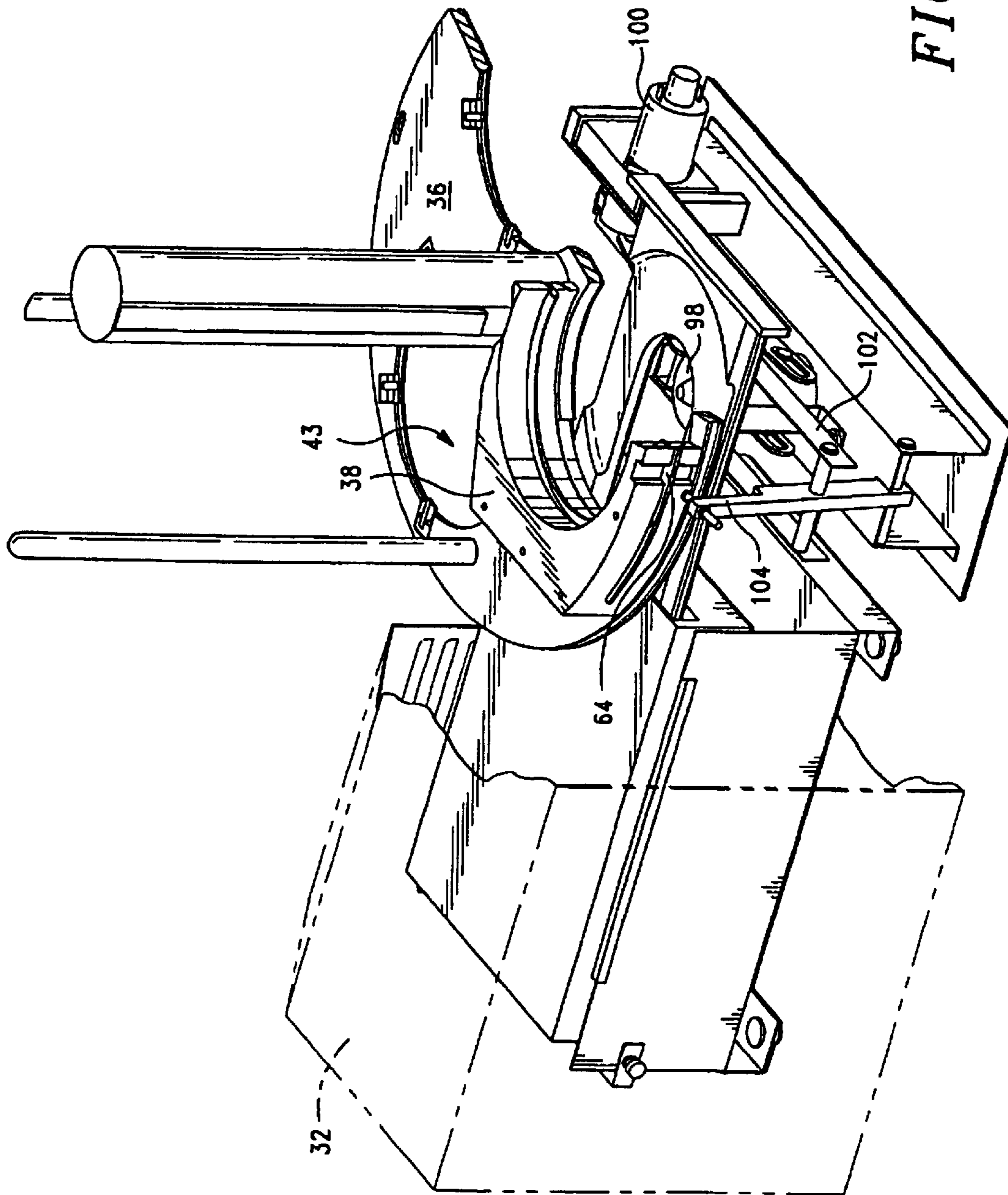

FIG. -6

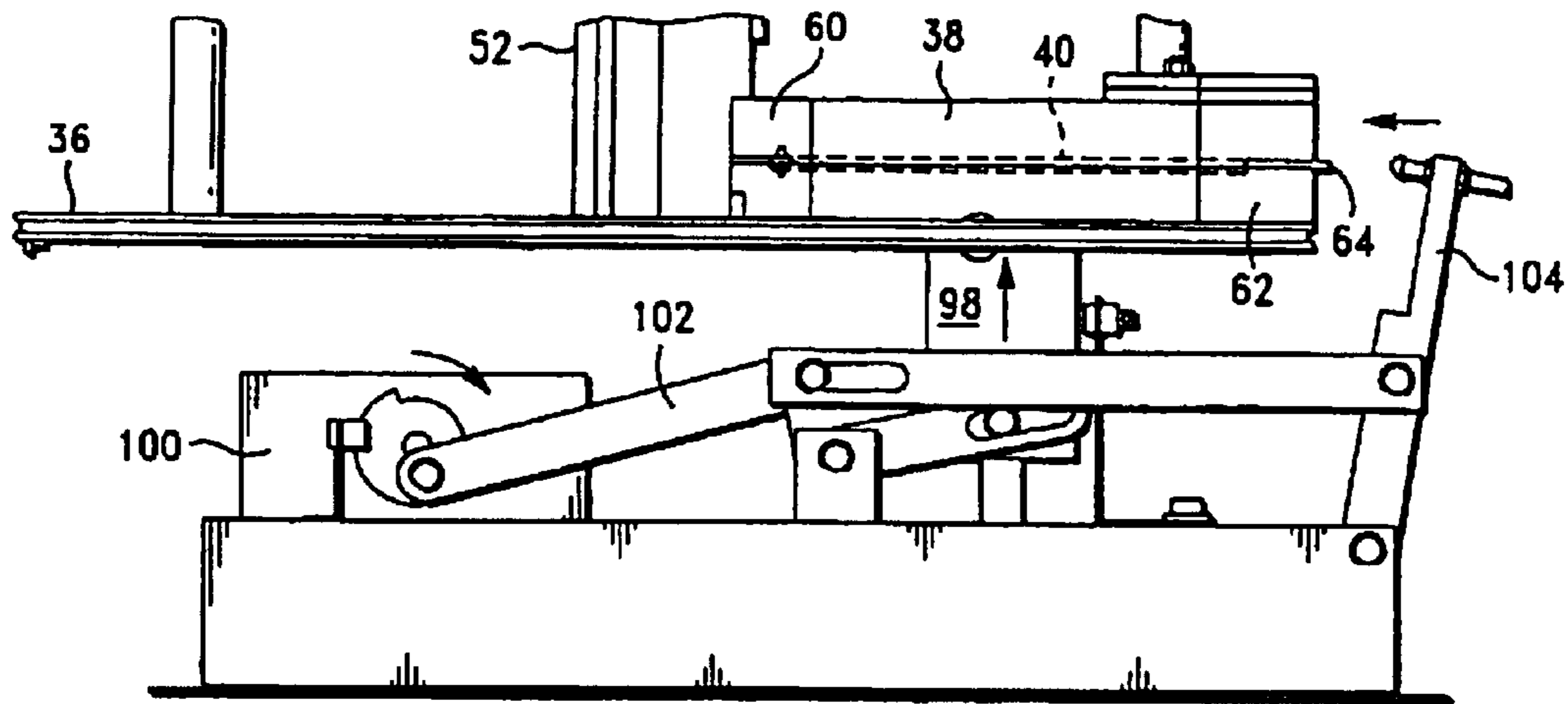

FIG.-7

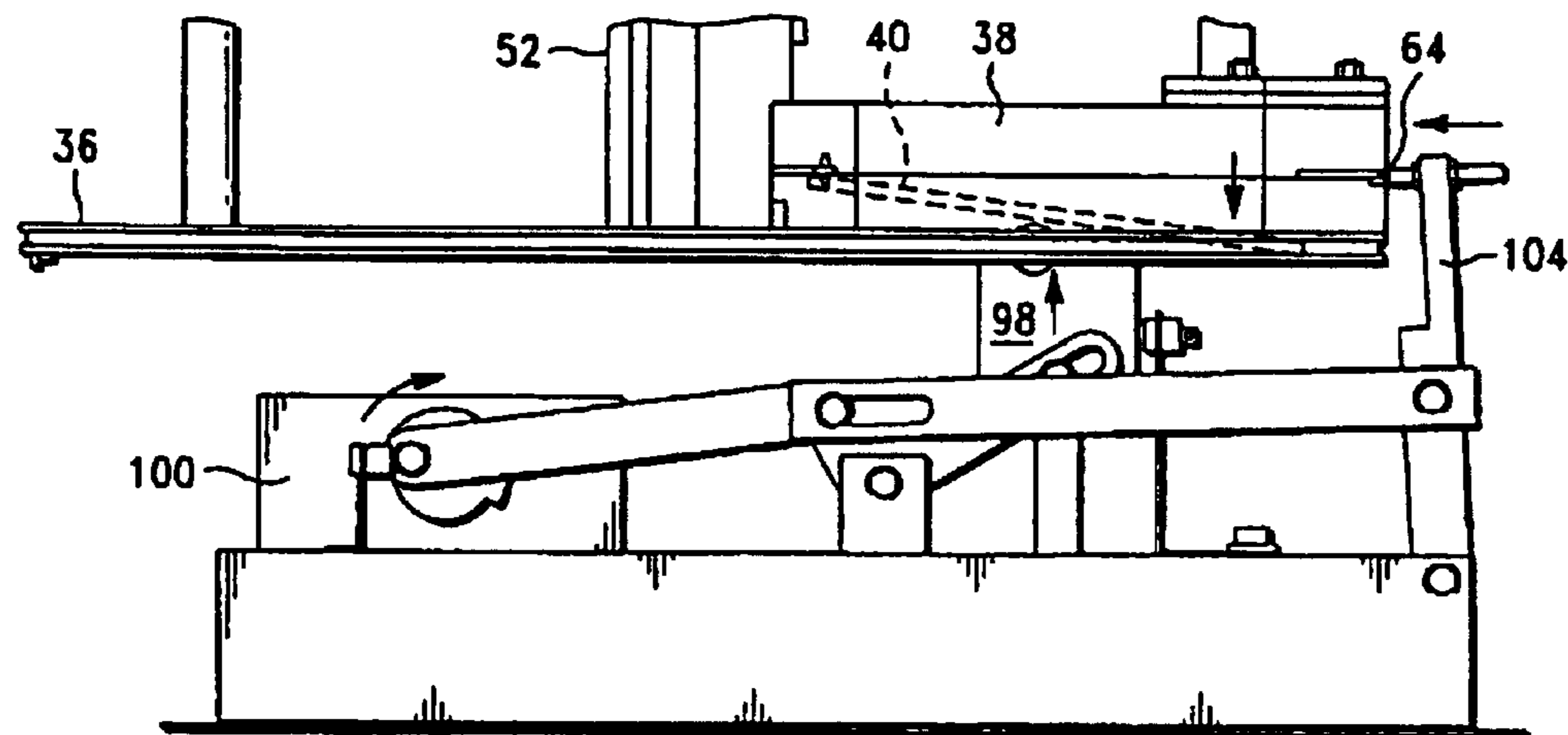

FIG.-8

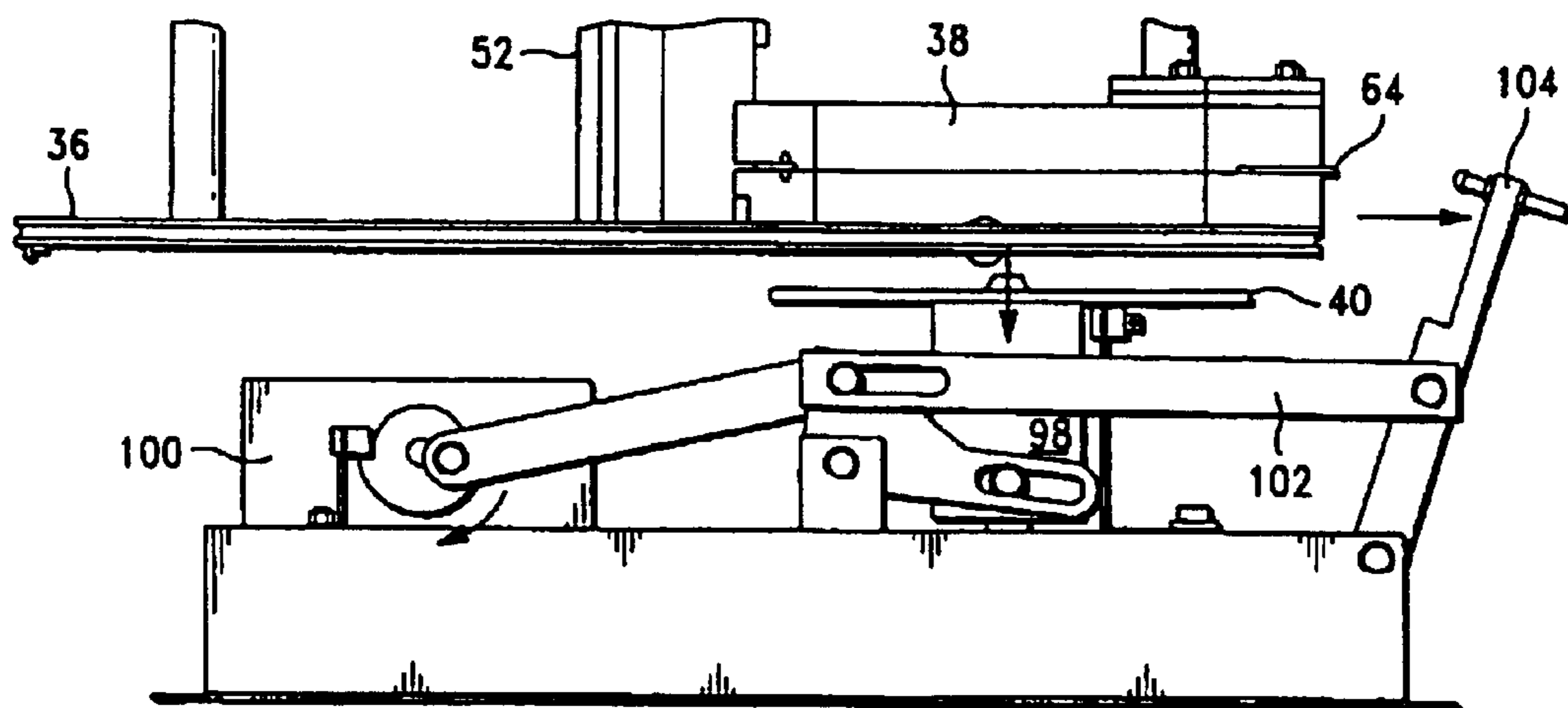

FIG.-9



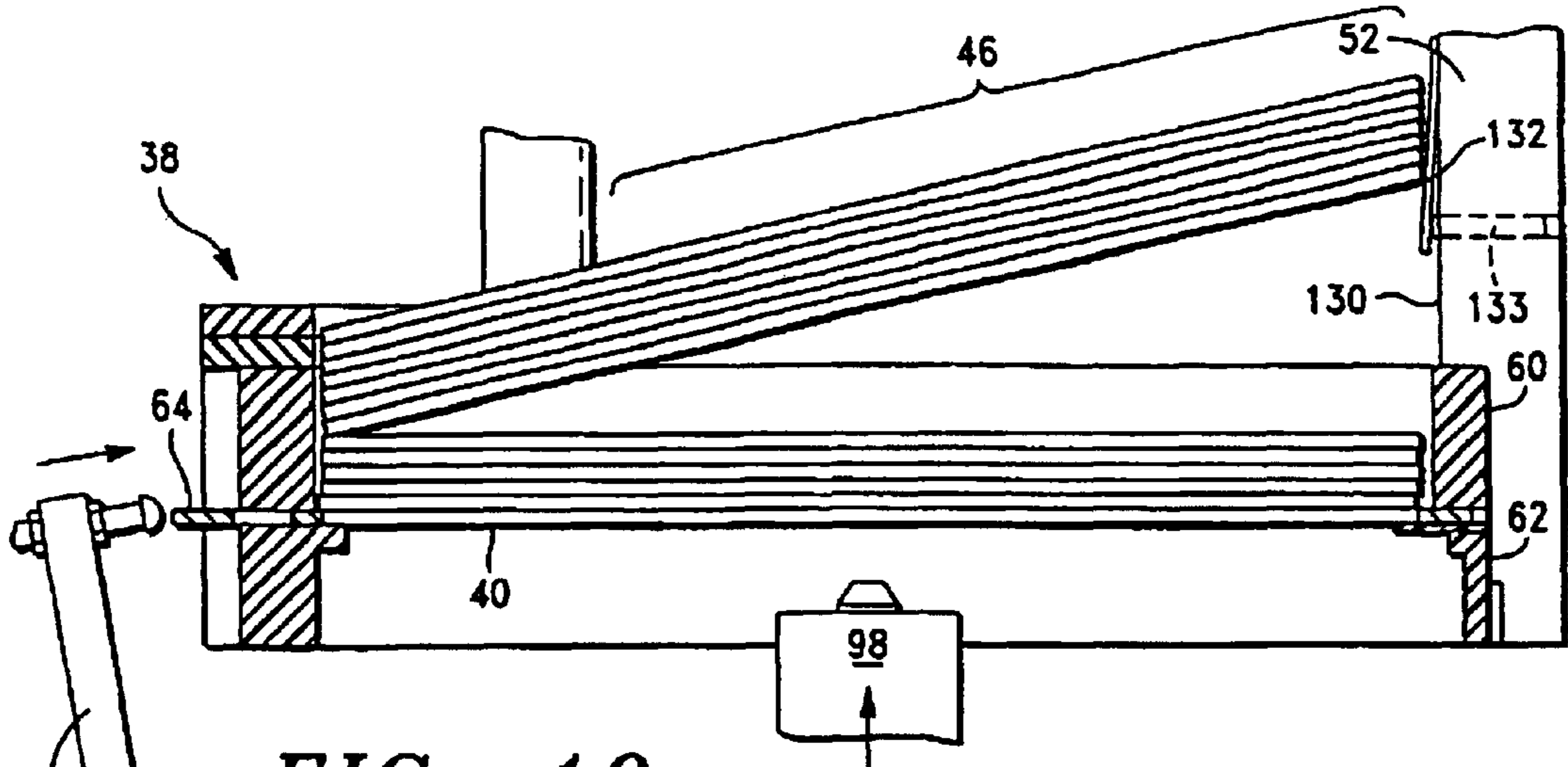

FIG. -10

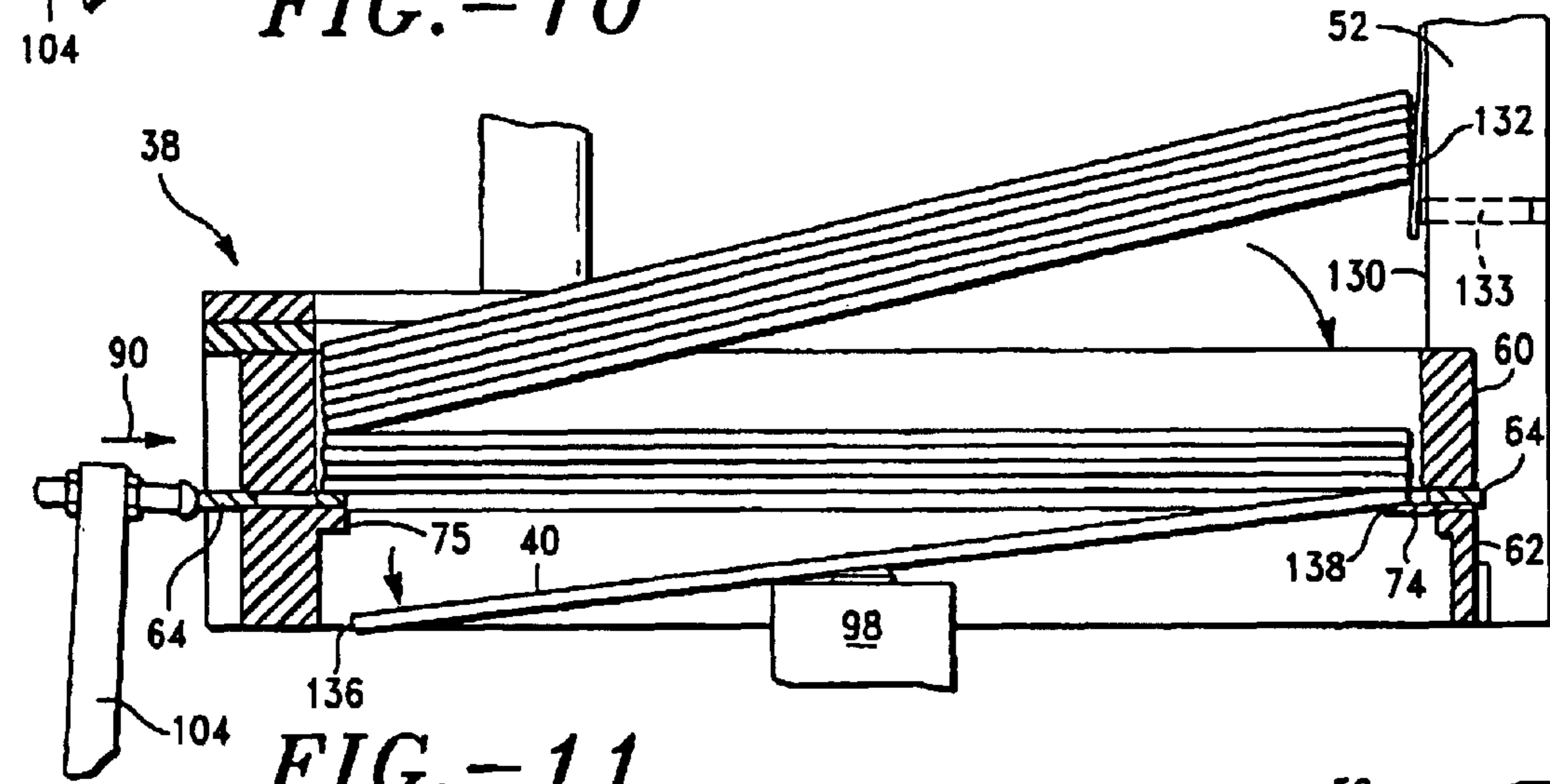

FIG. -11

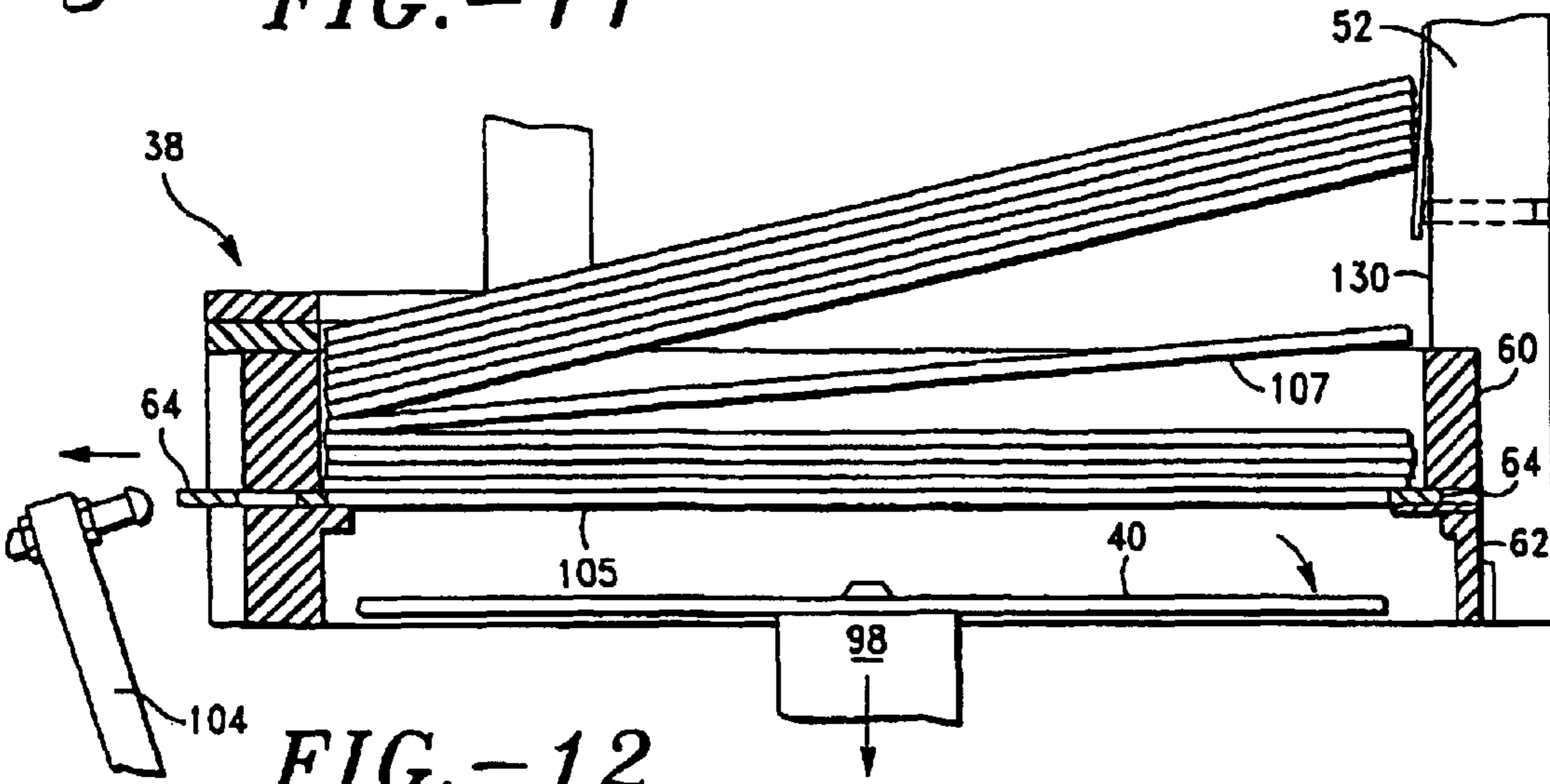

FIG. -12

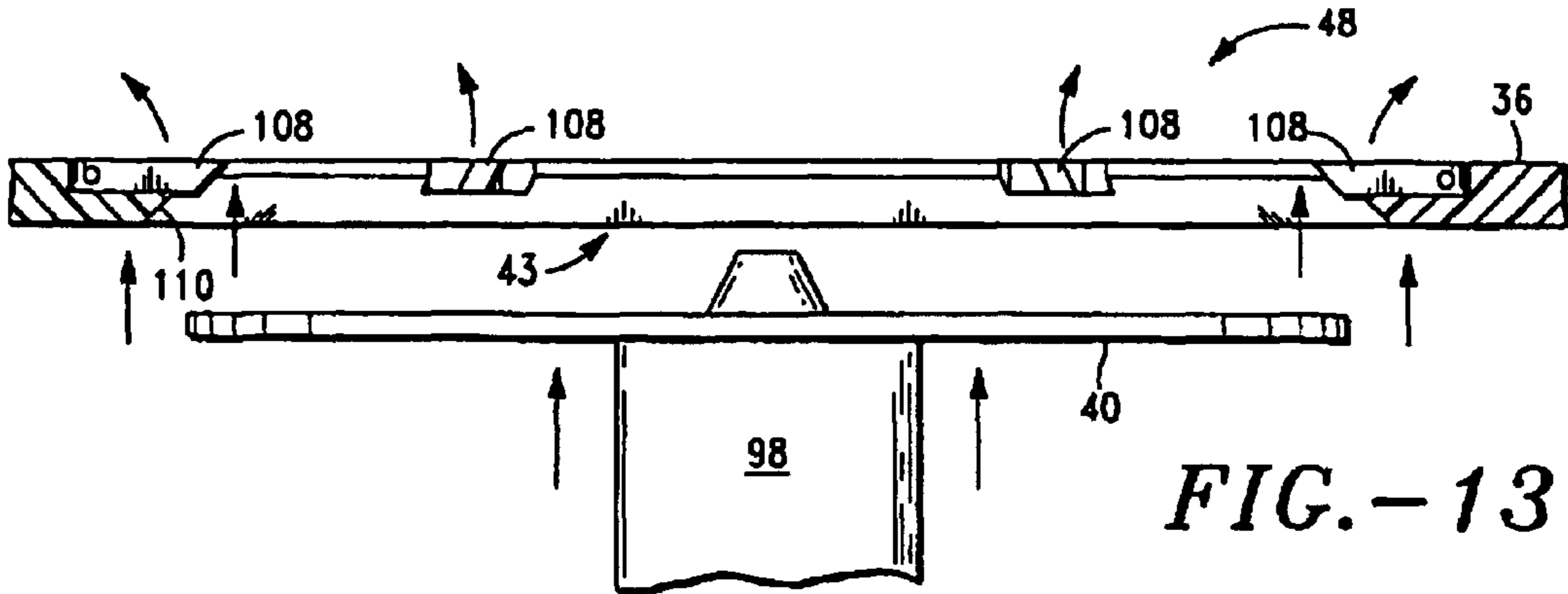

FIG. -13

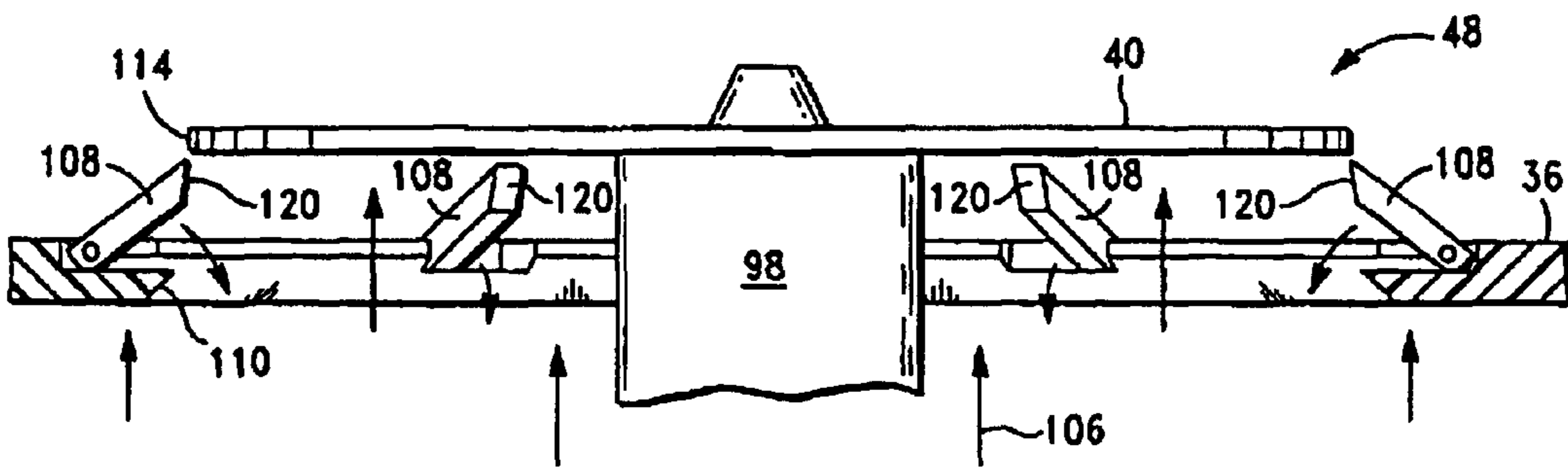

FIG. -14

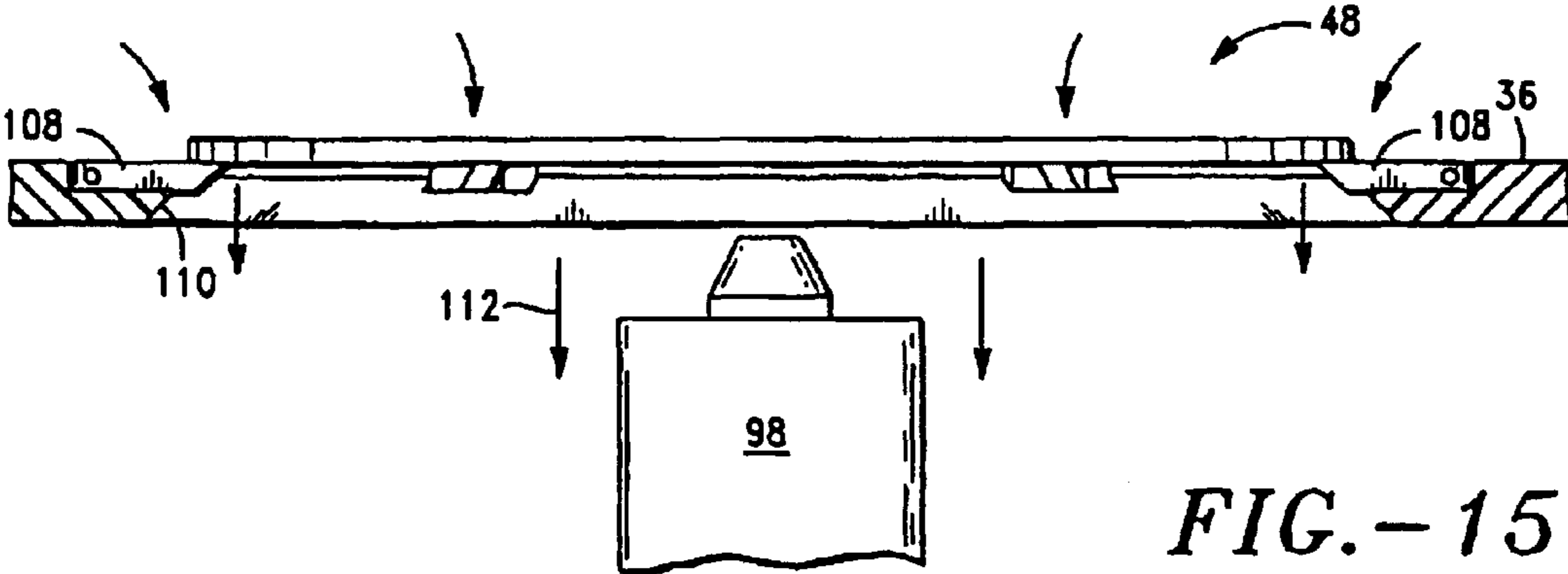

FIG. -15

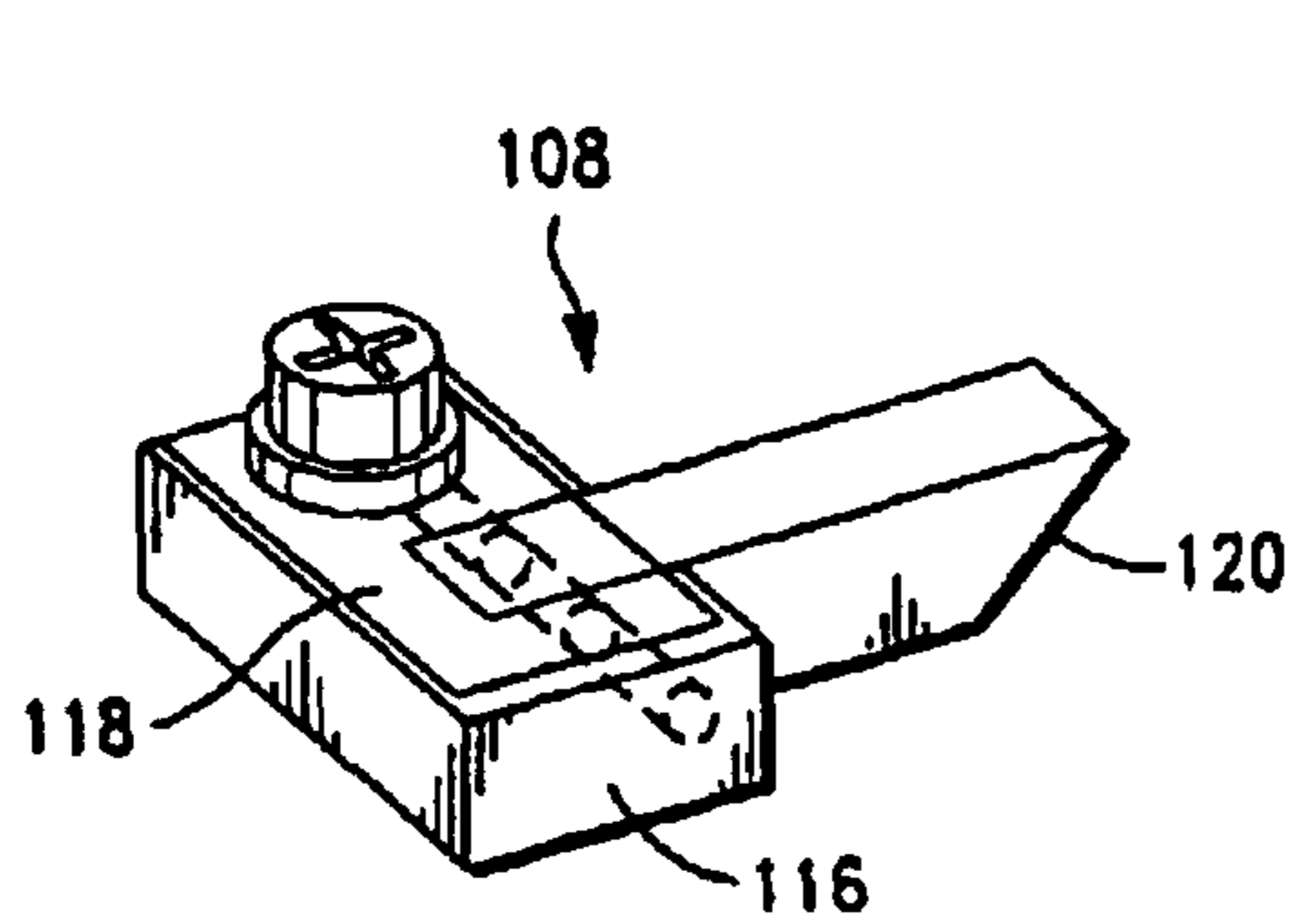

FIG. -16

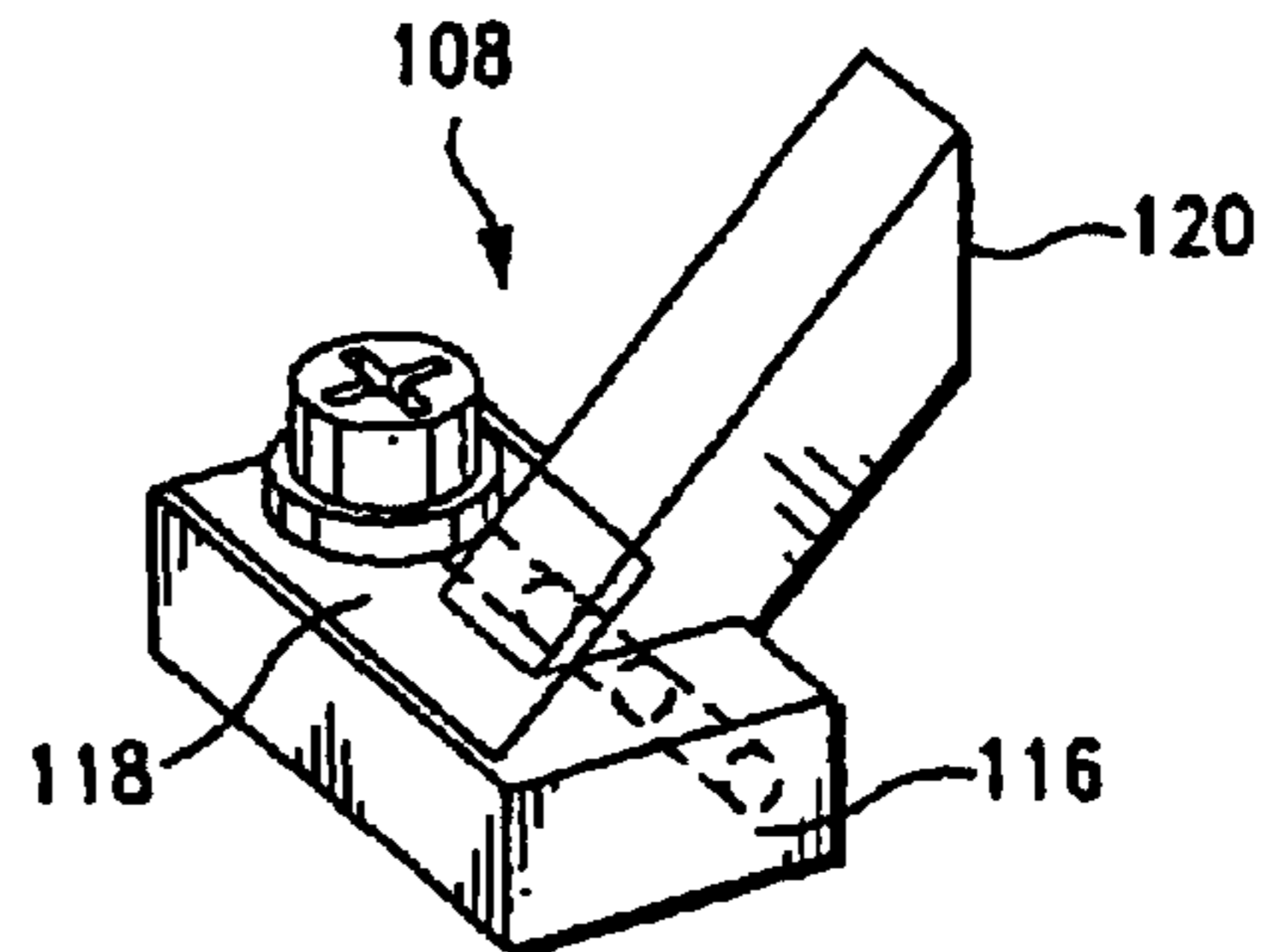

FIG. -17

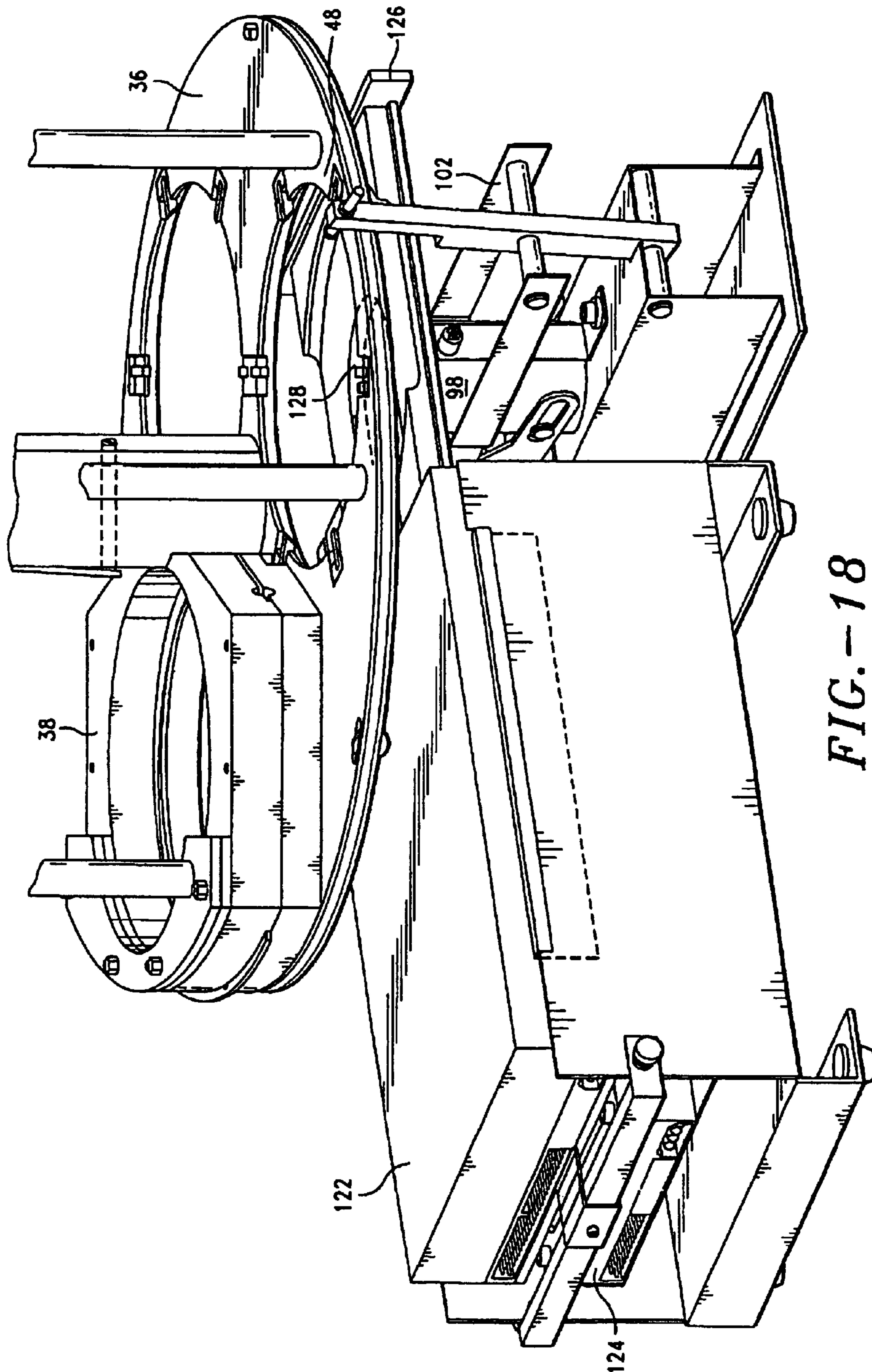

FIG. - 18

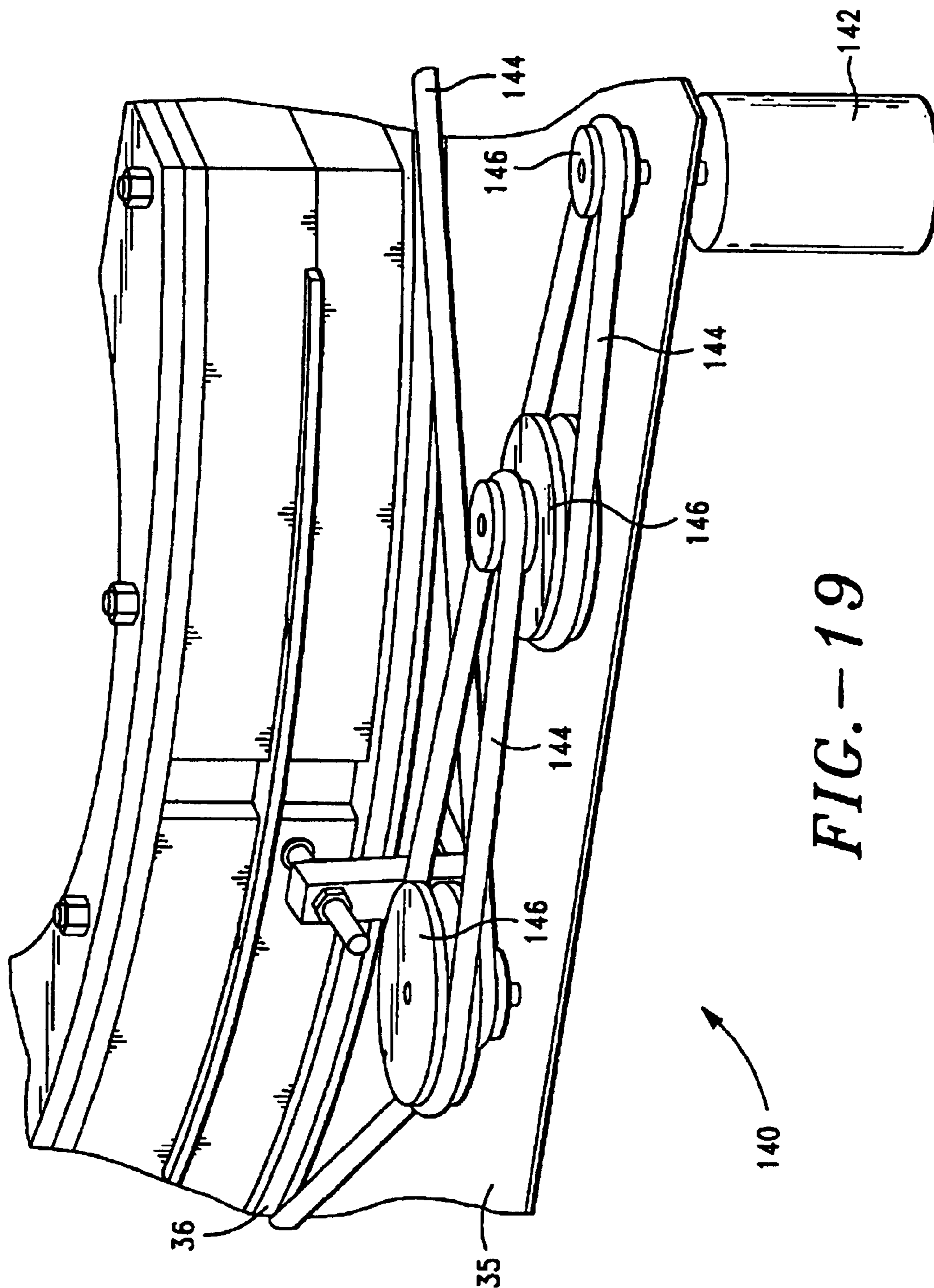

FIG. - 19

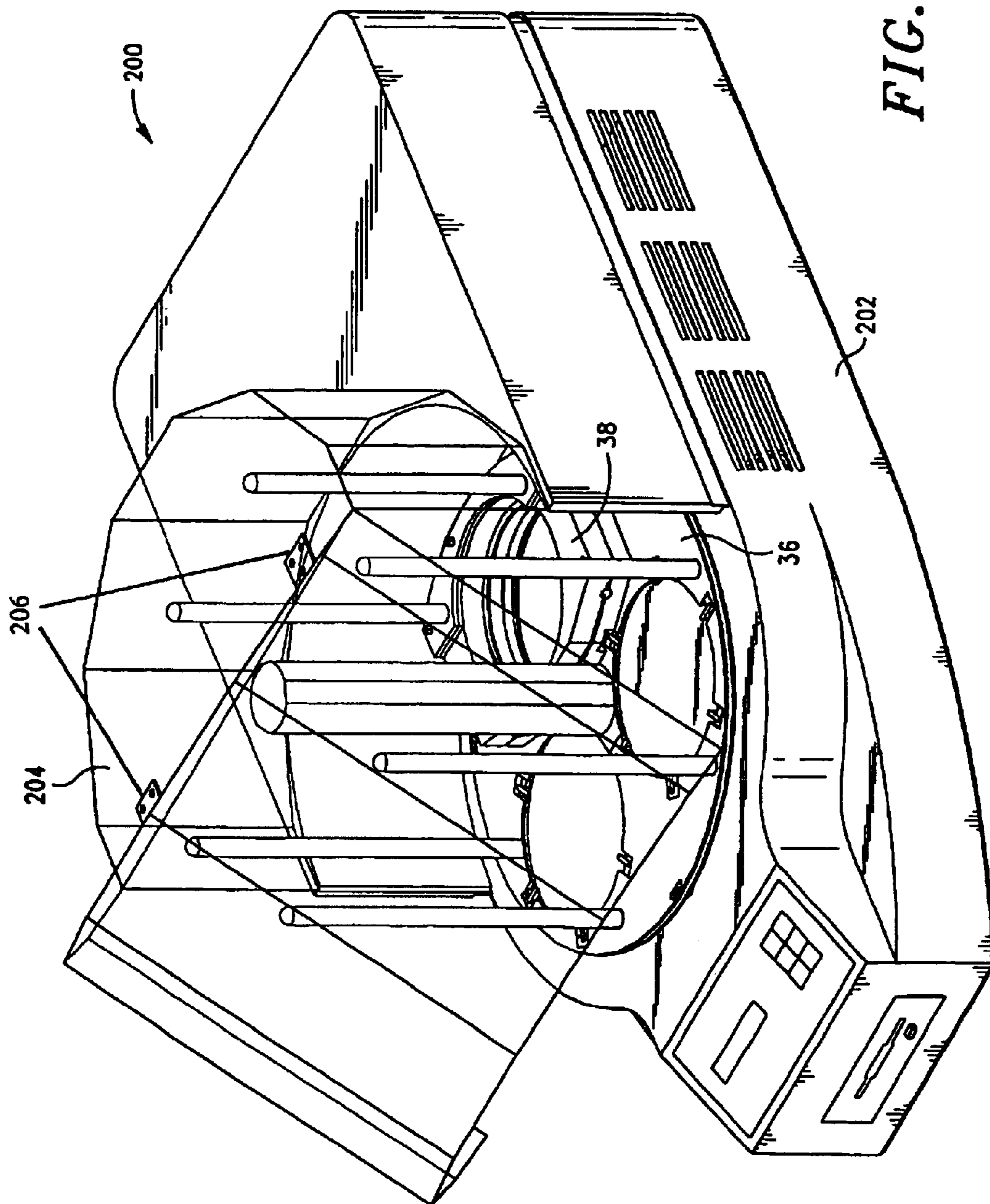

FIG. -20

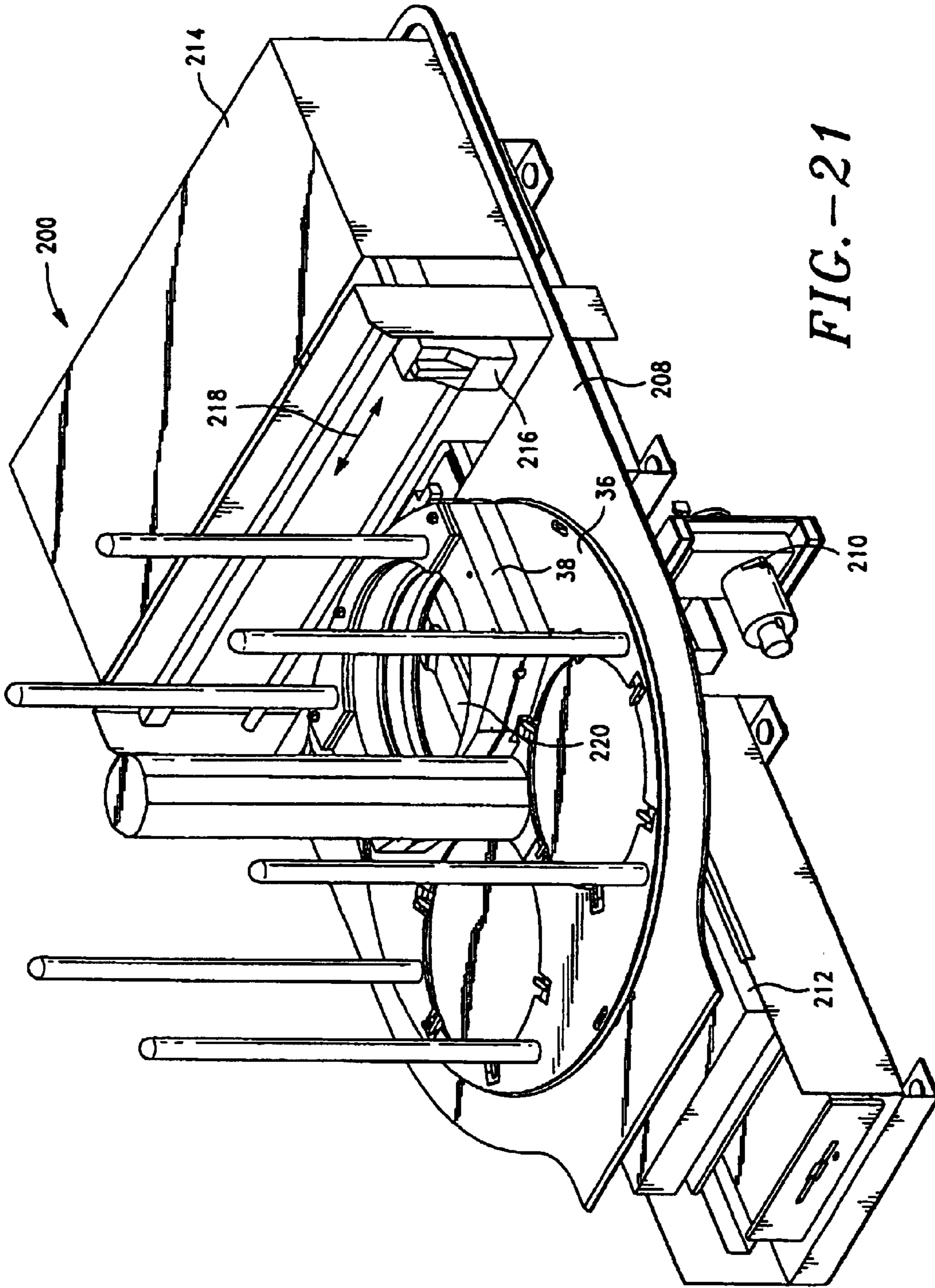

FIG.-21

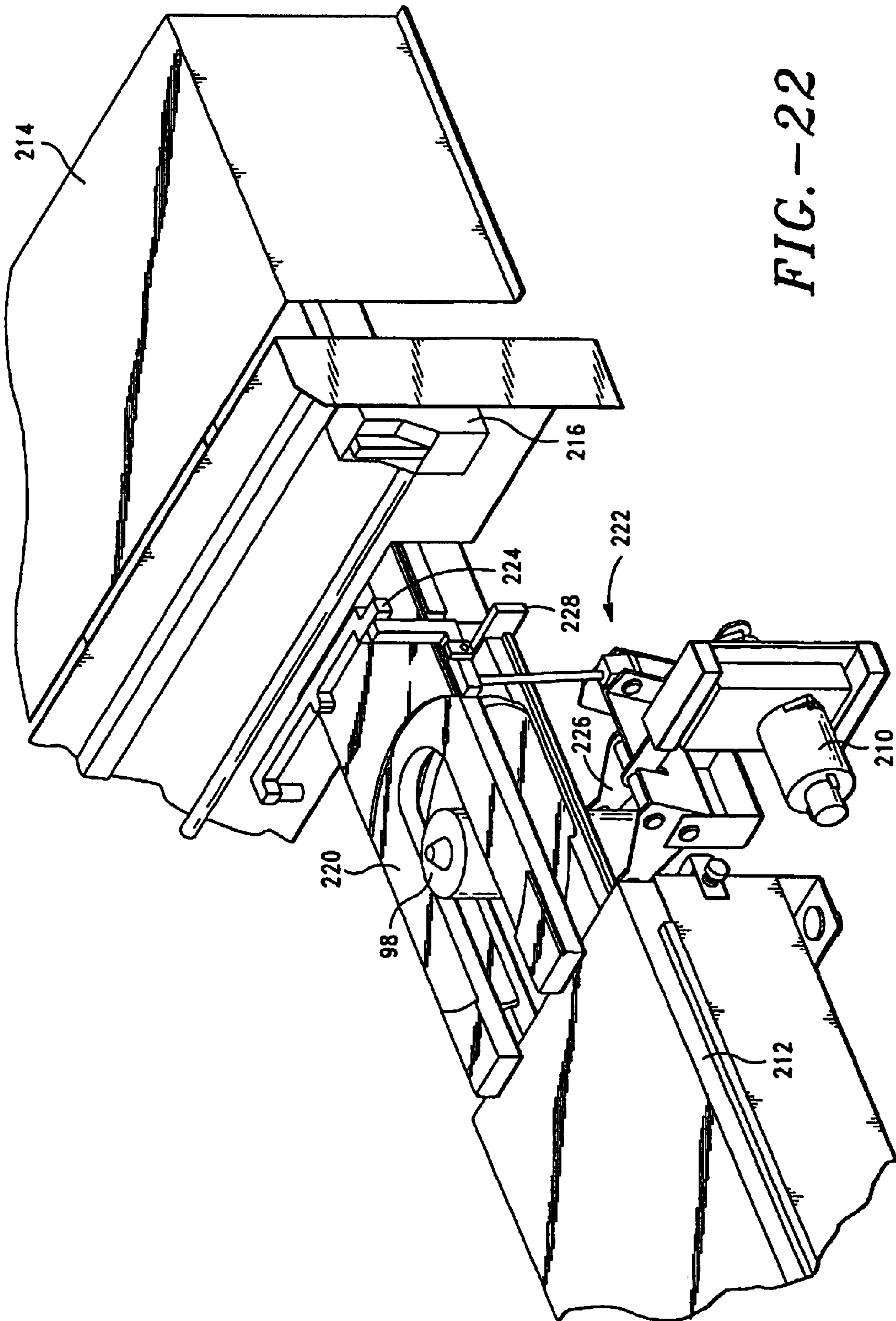
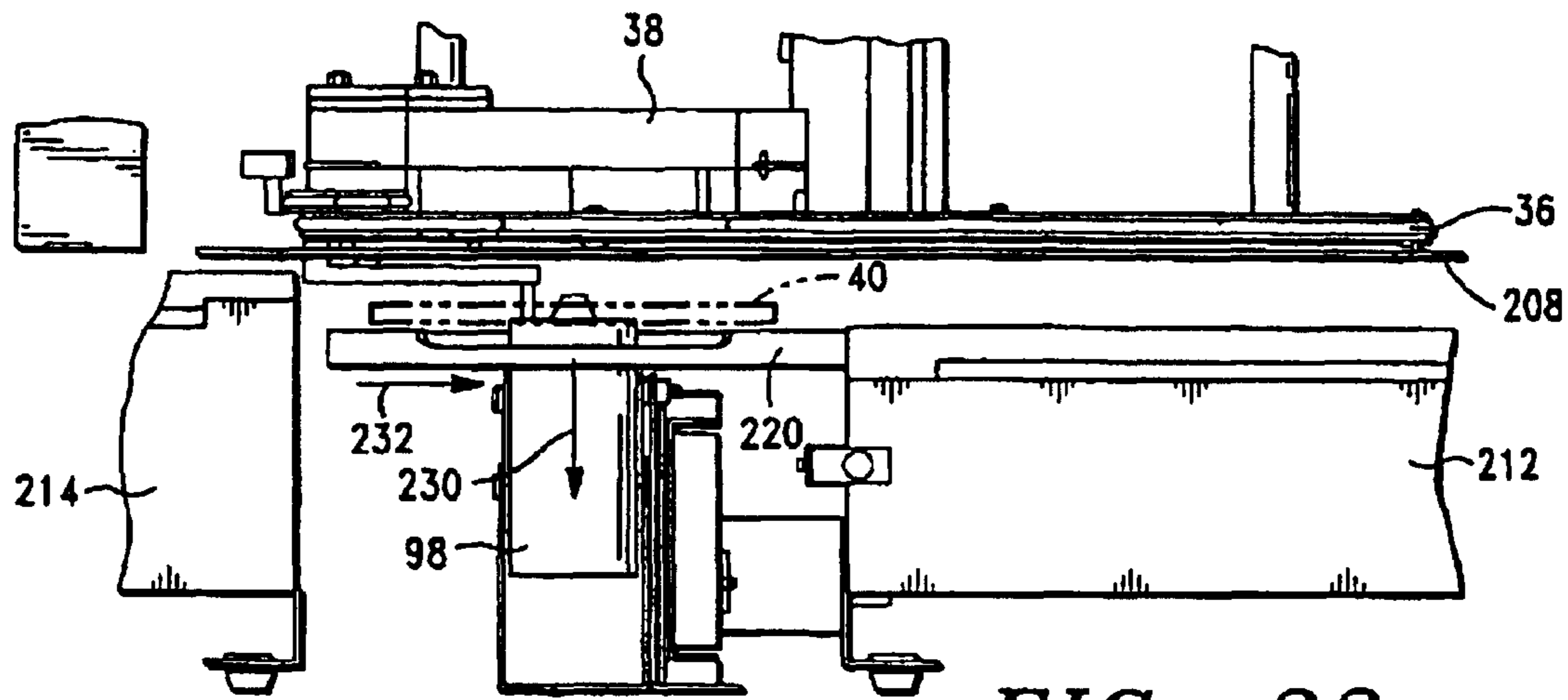
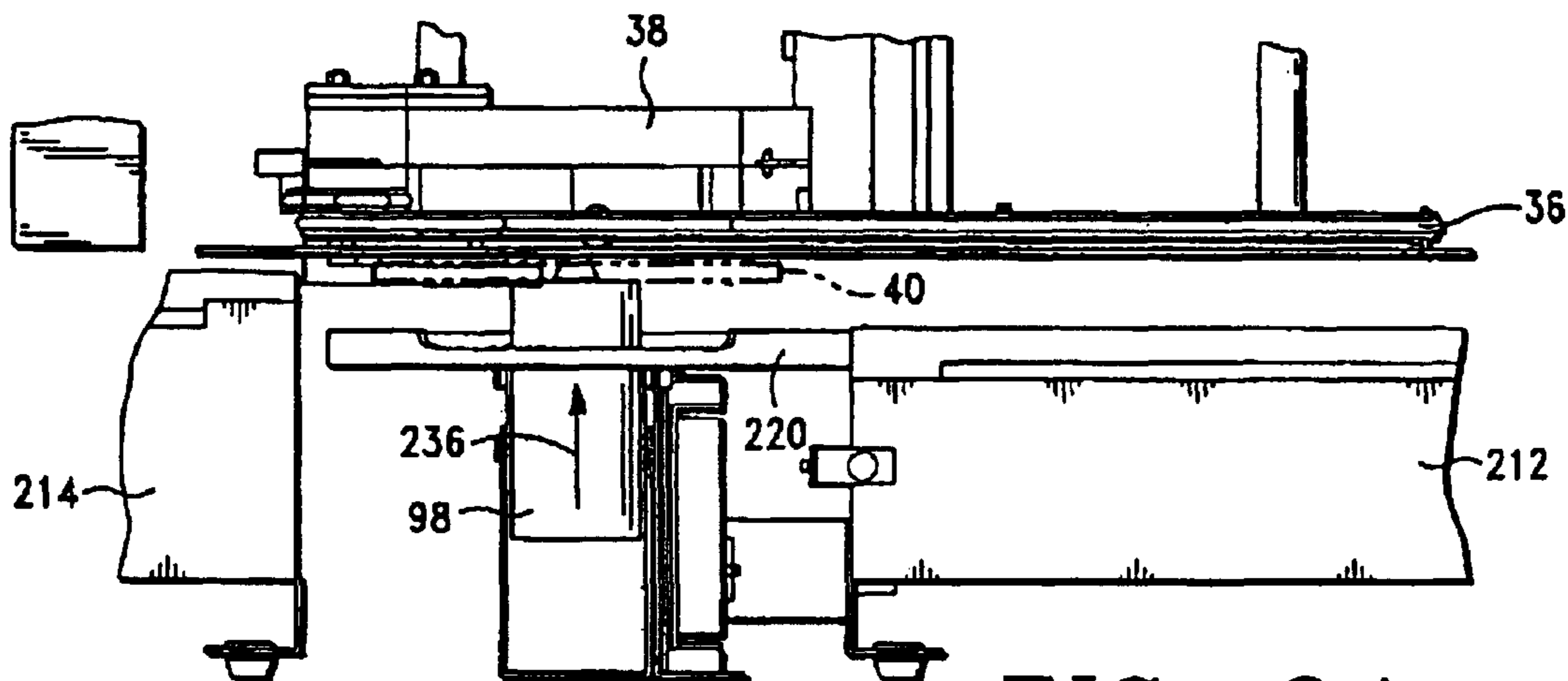

FIG. - 22



*FIG. -23*



*FIG. -24*

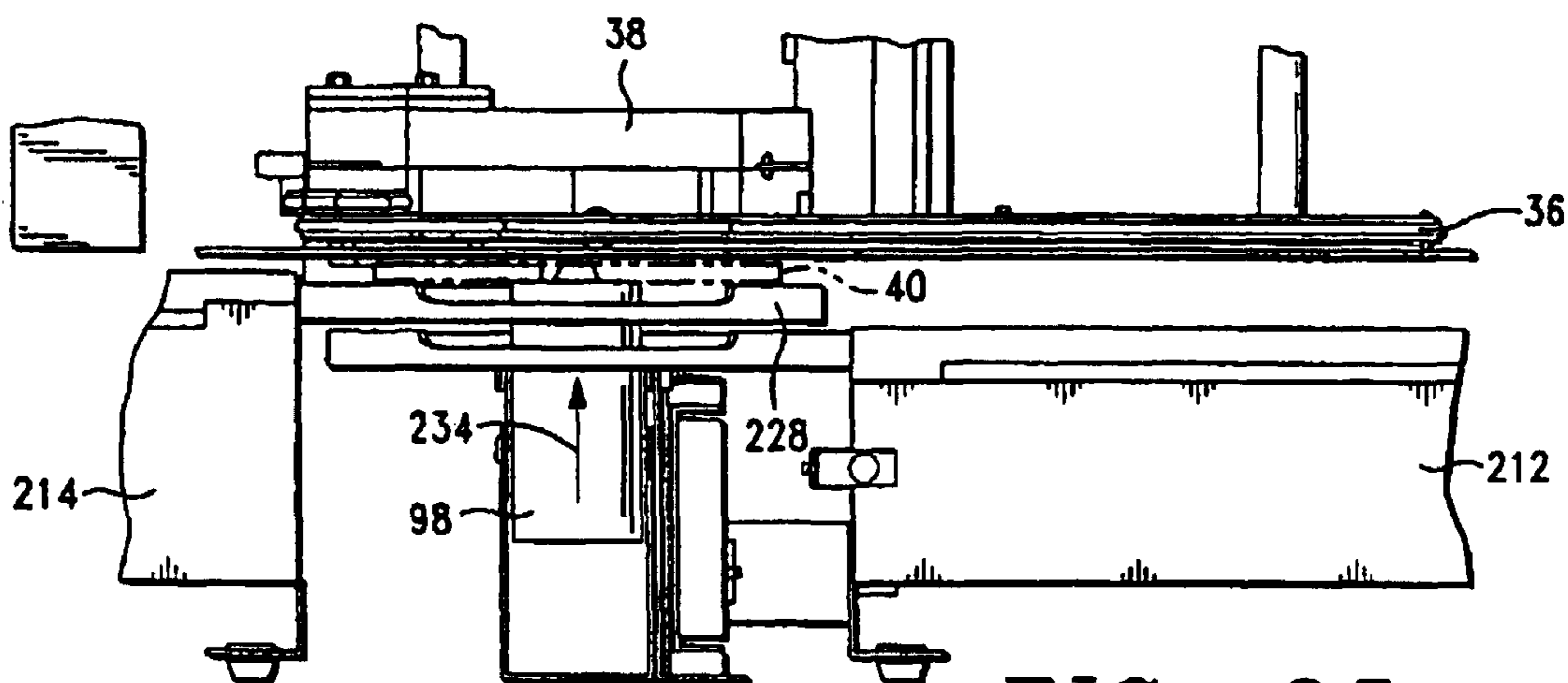

*FIG. -25*



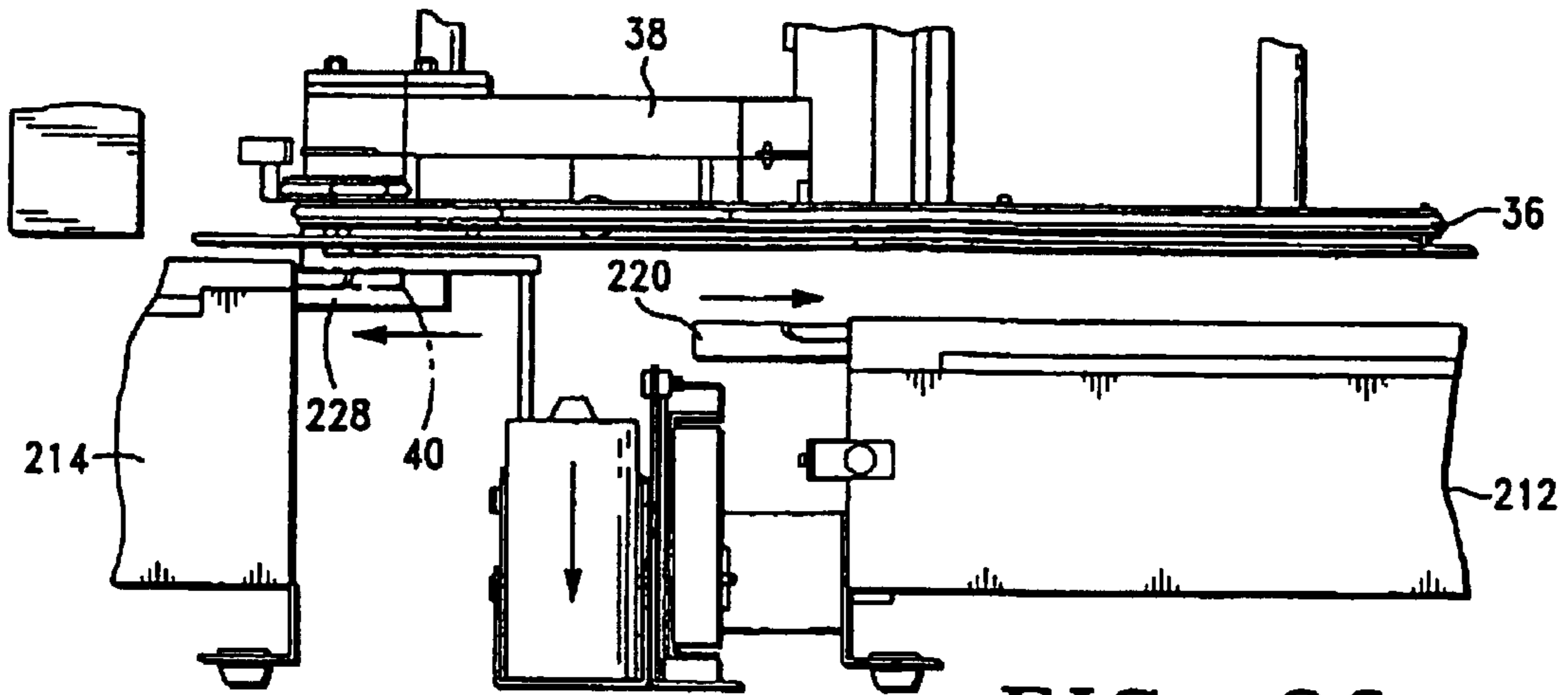

FIG.-26

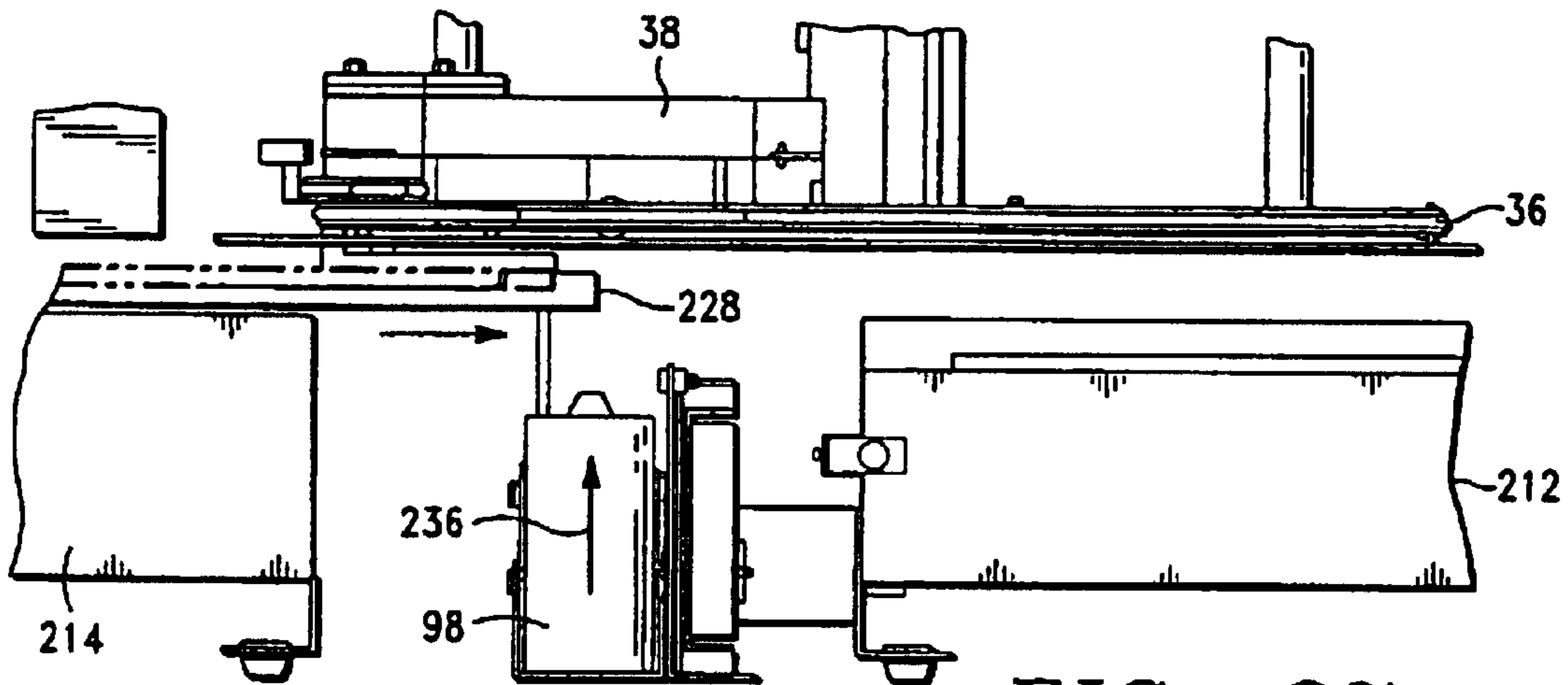

FIG.-27

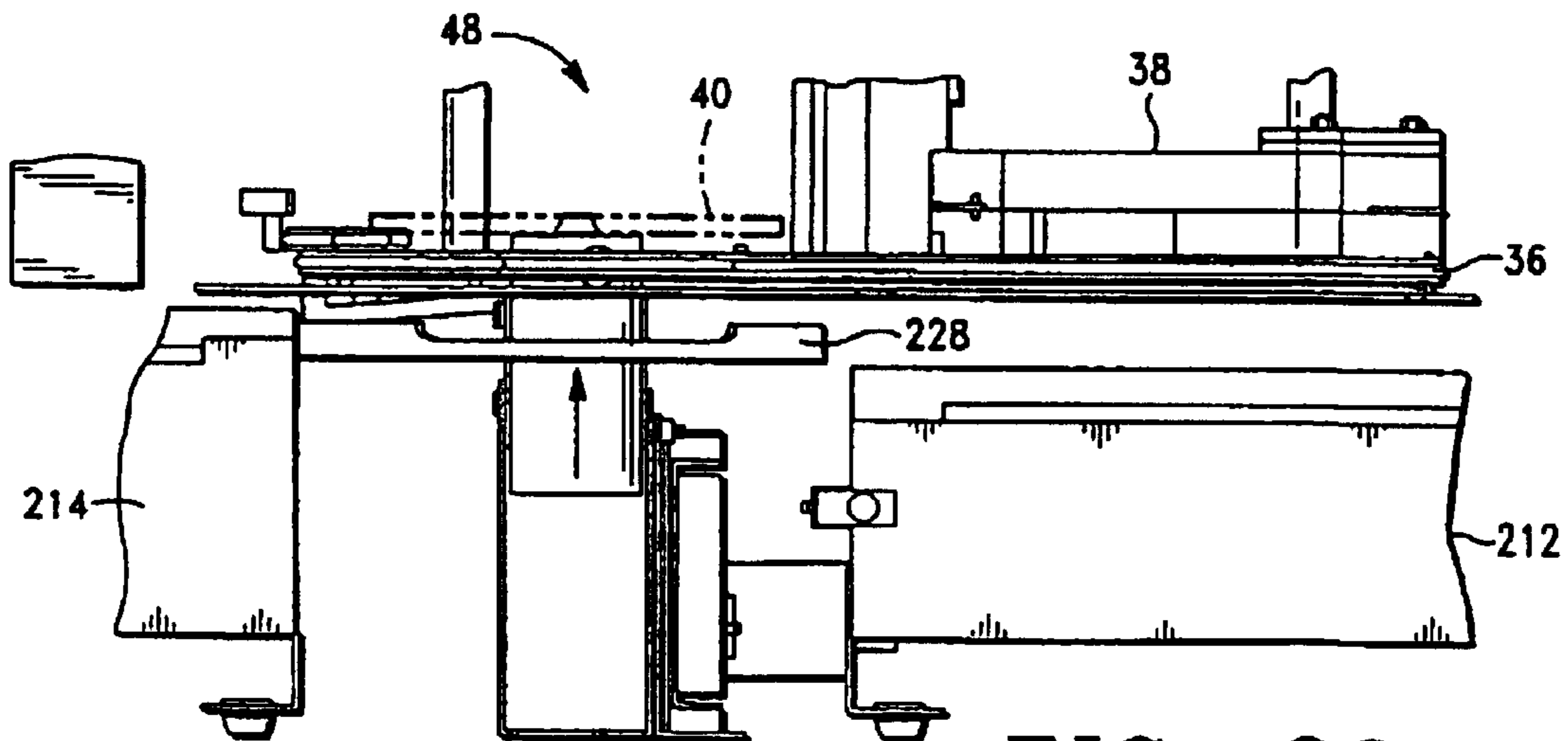

FIG.-28

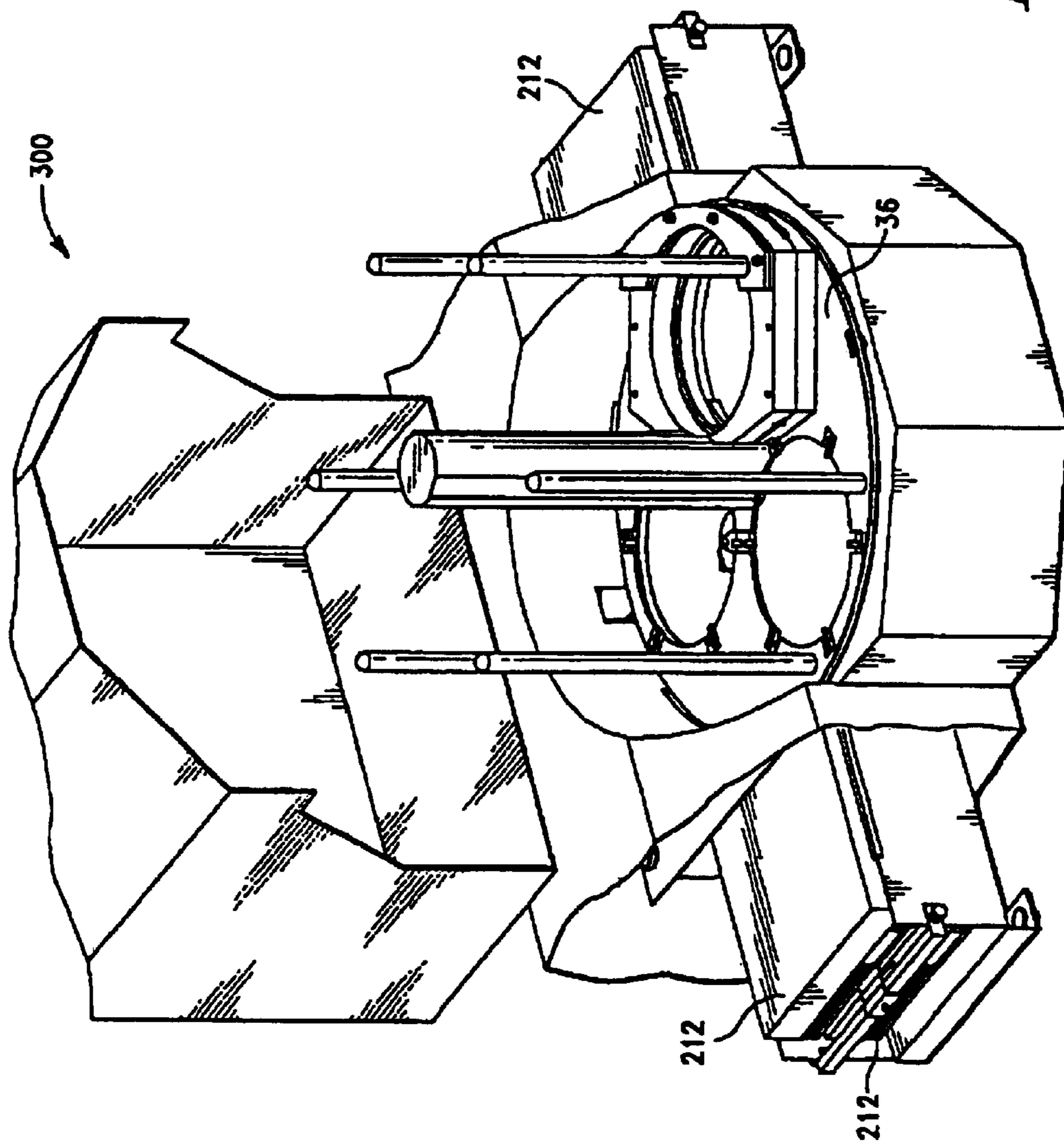

FIG. - 29

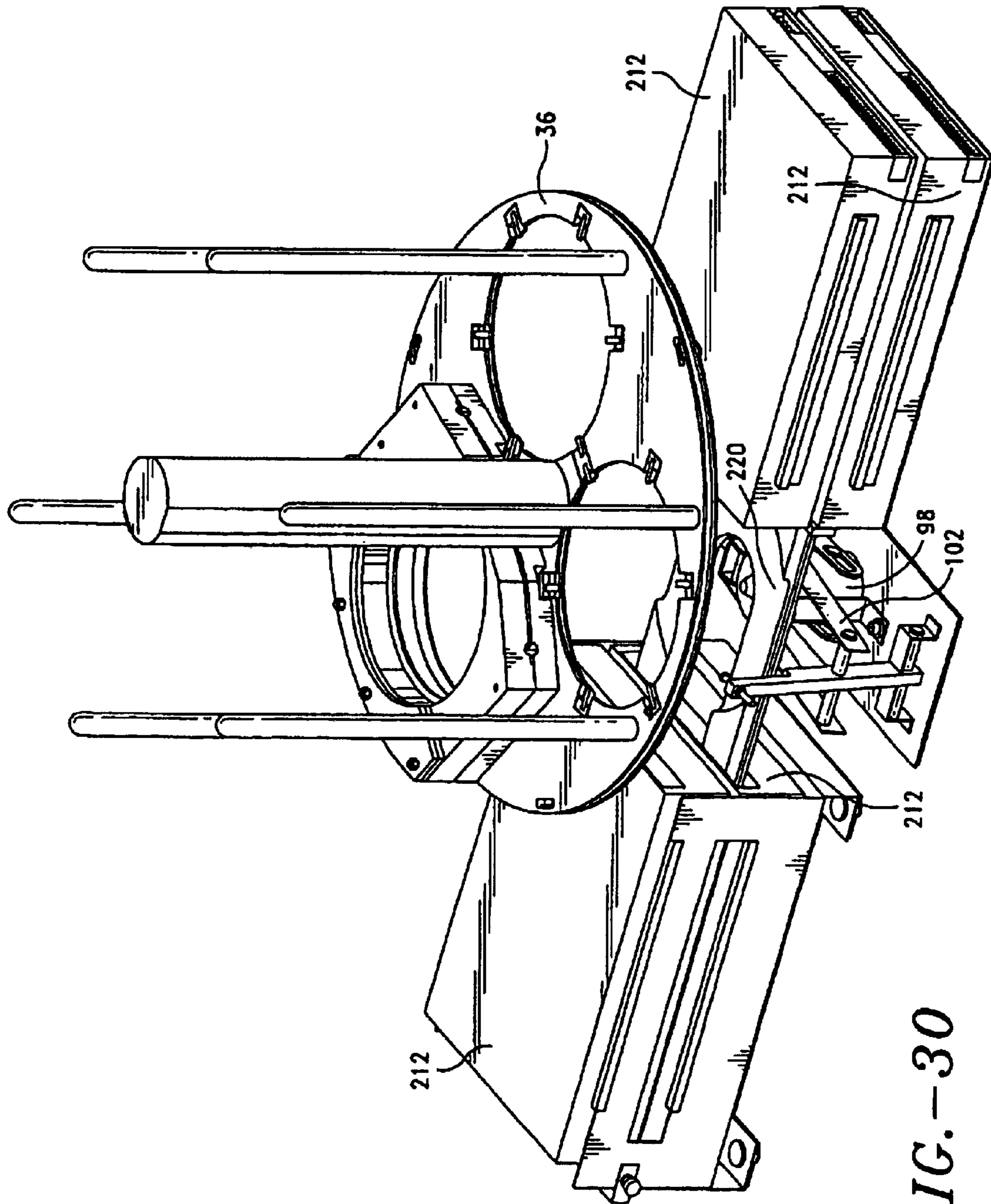

FIG.-30

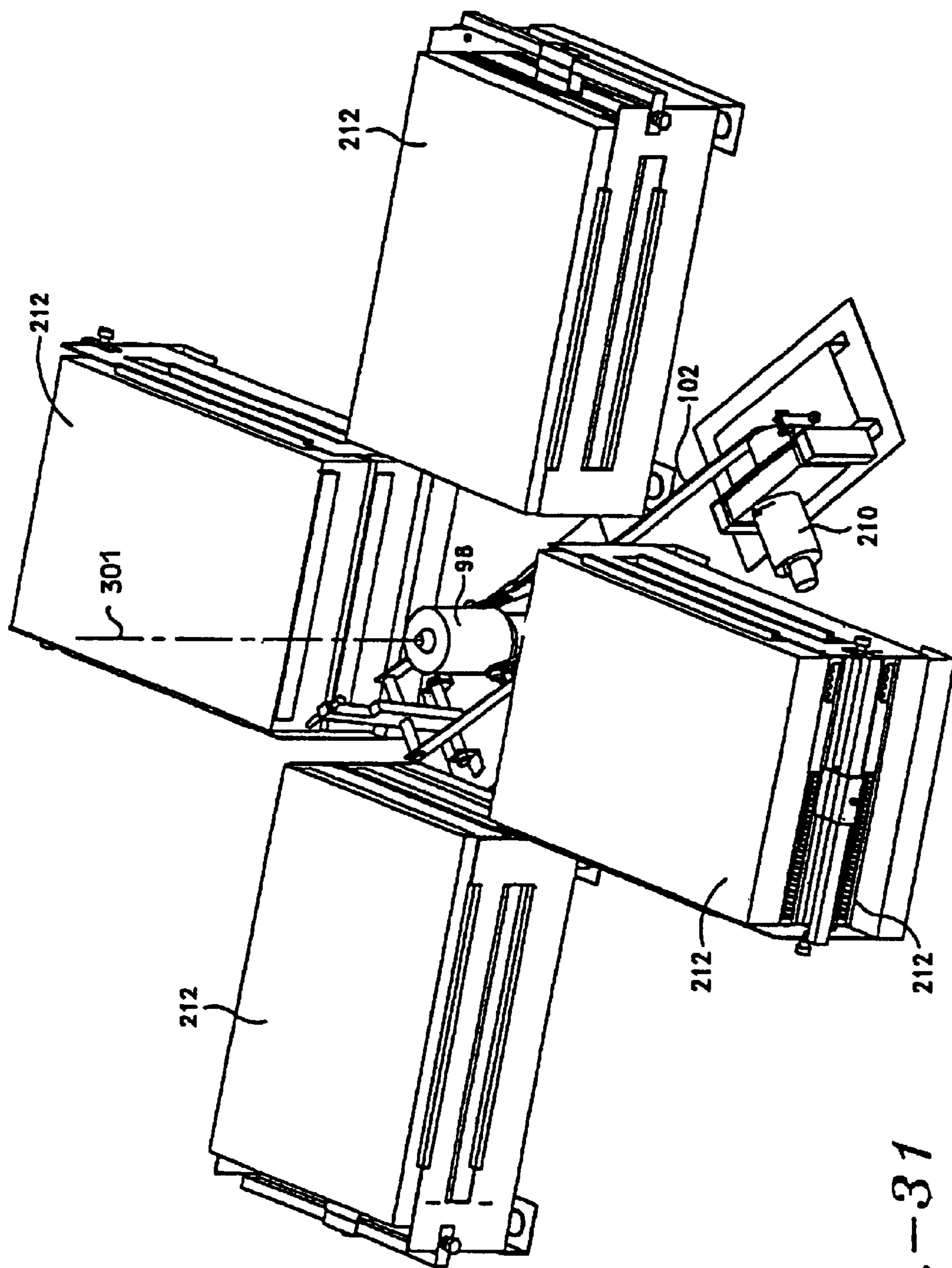

FIG. -31

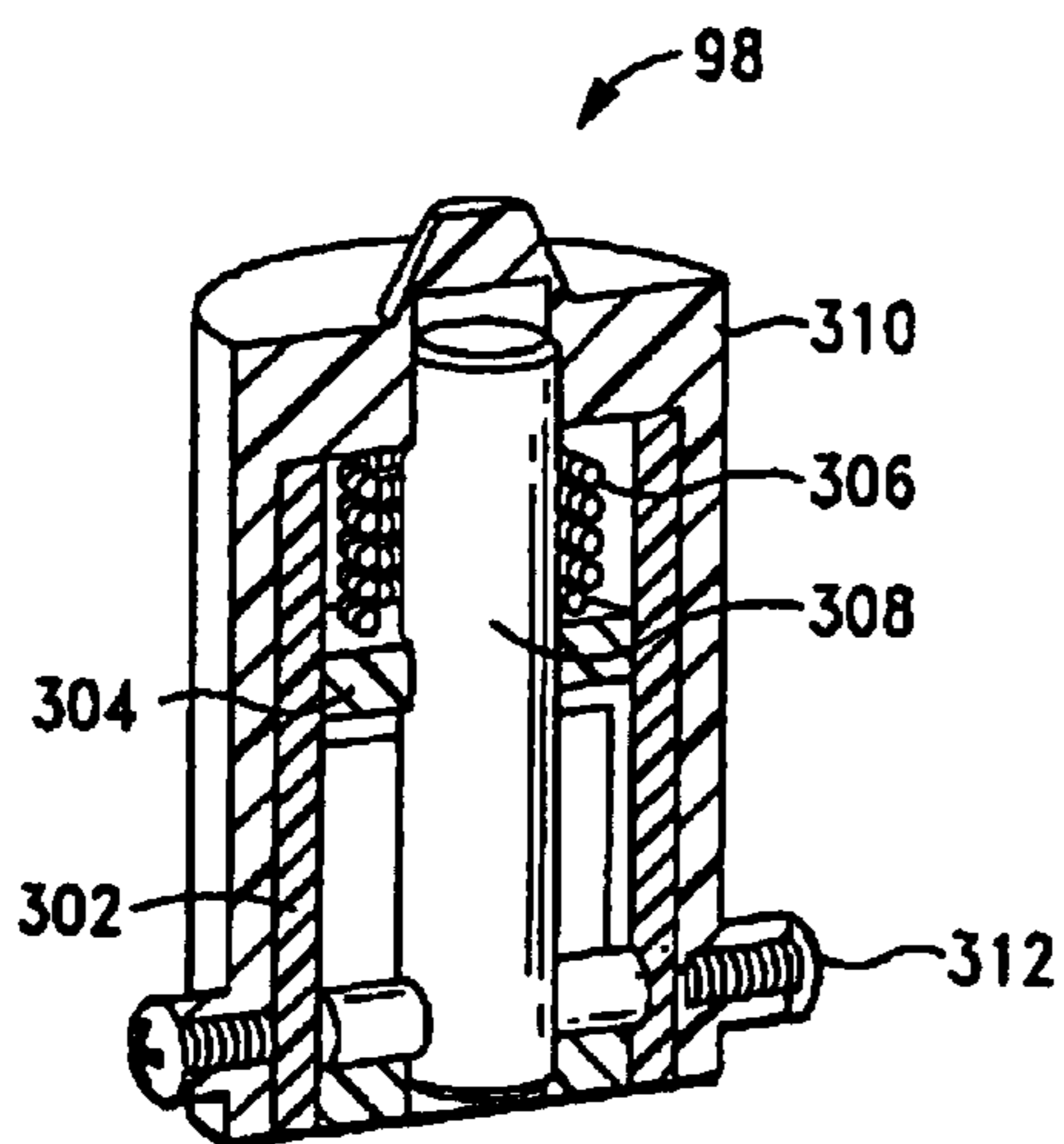

FIG. -32

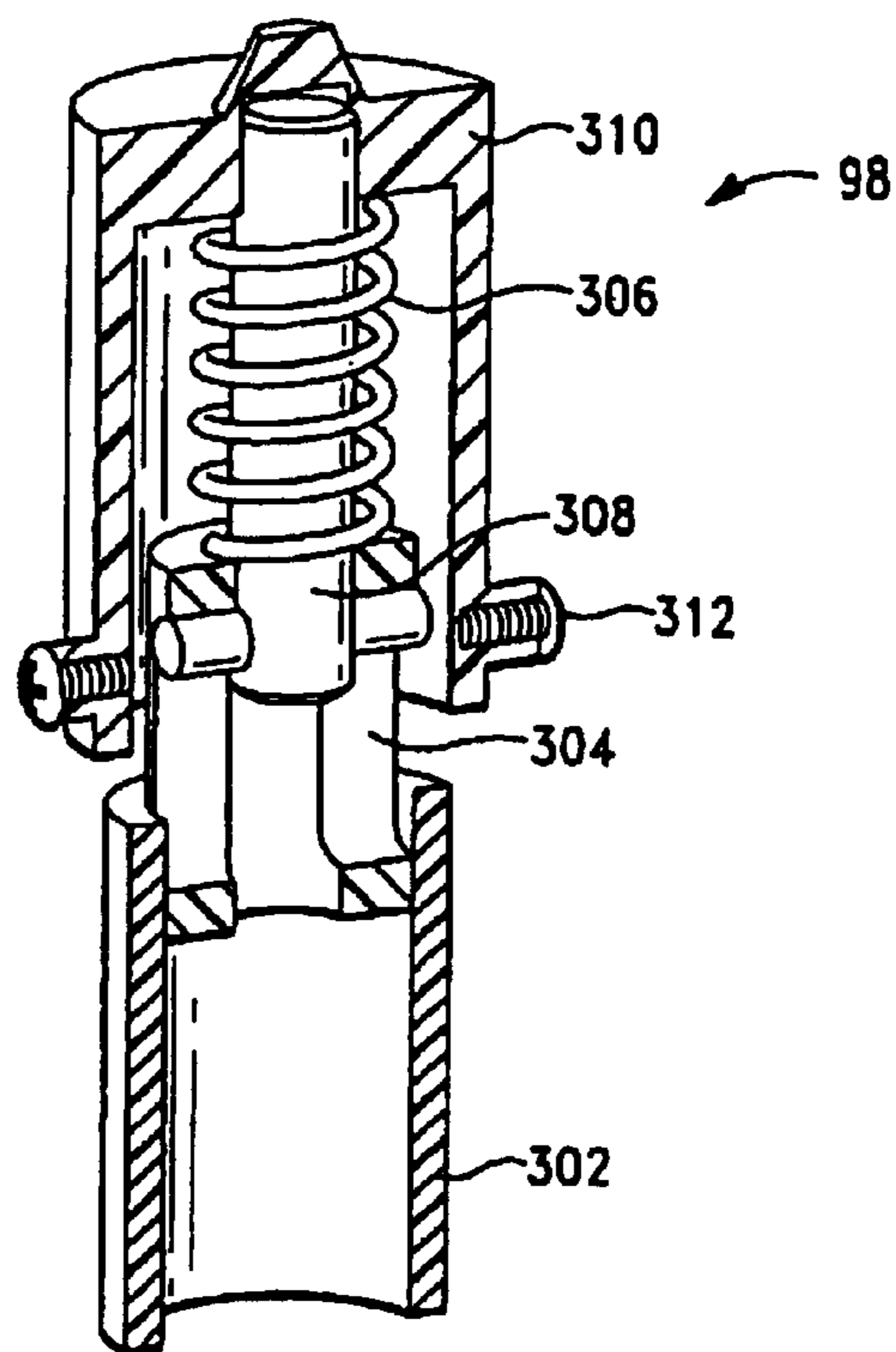

FIG. -33

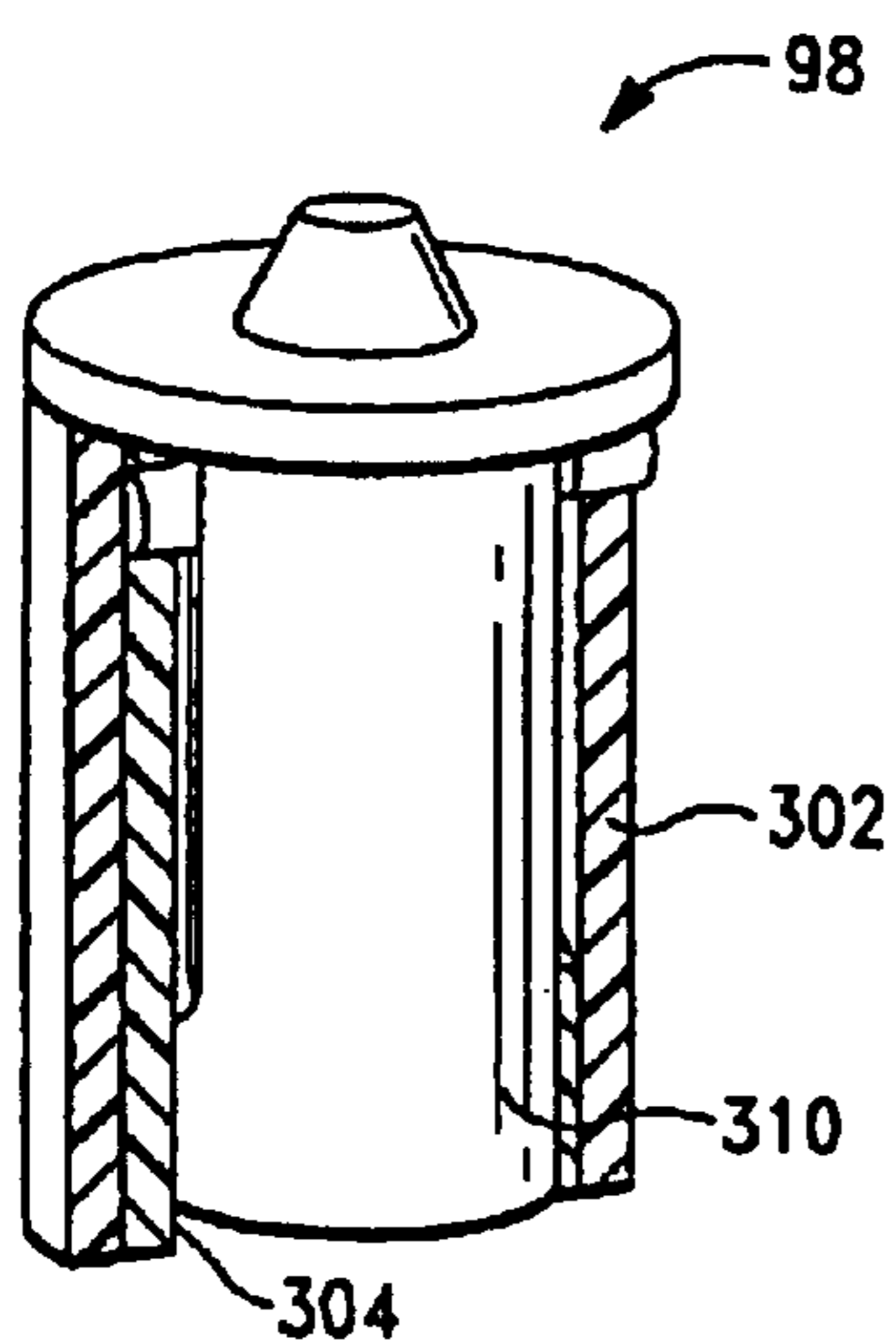

FIG. -34

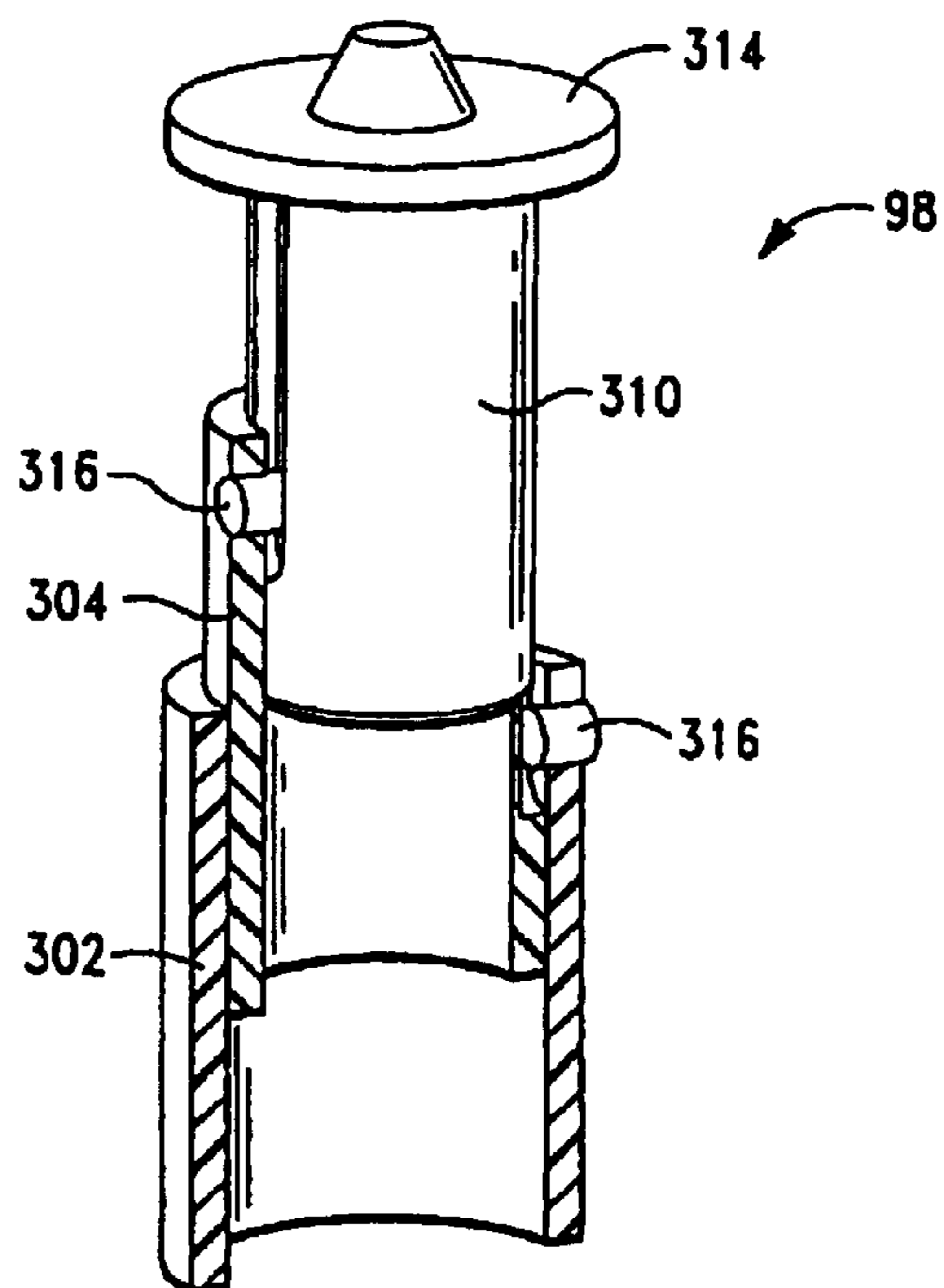
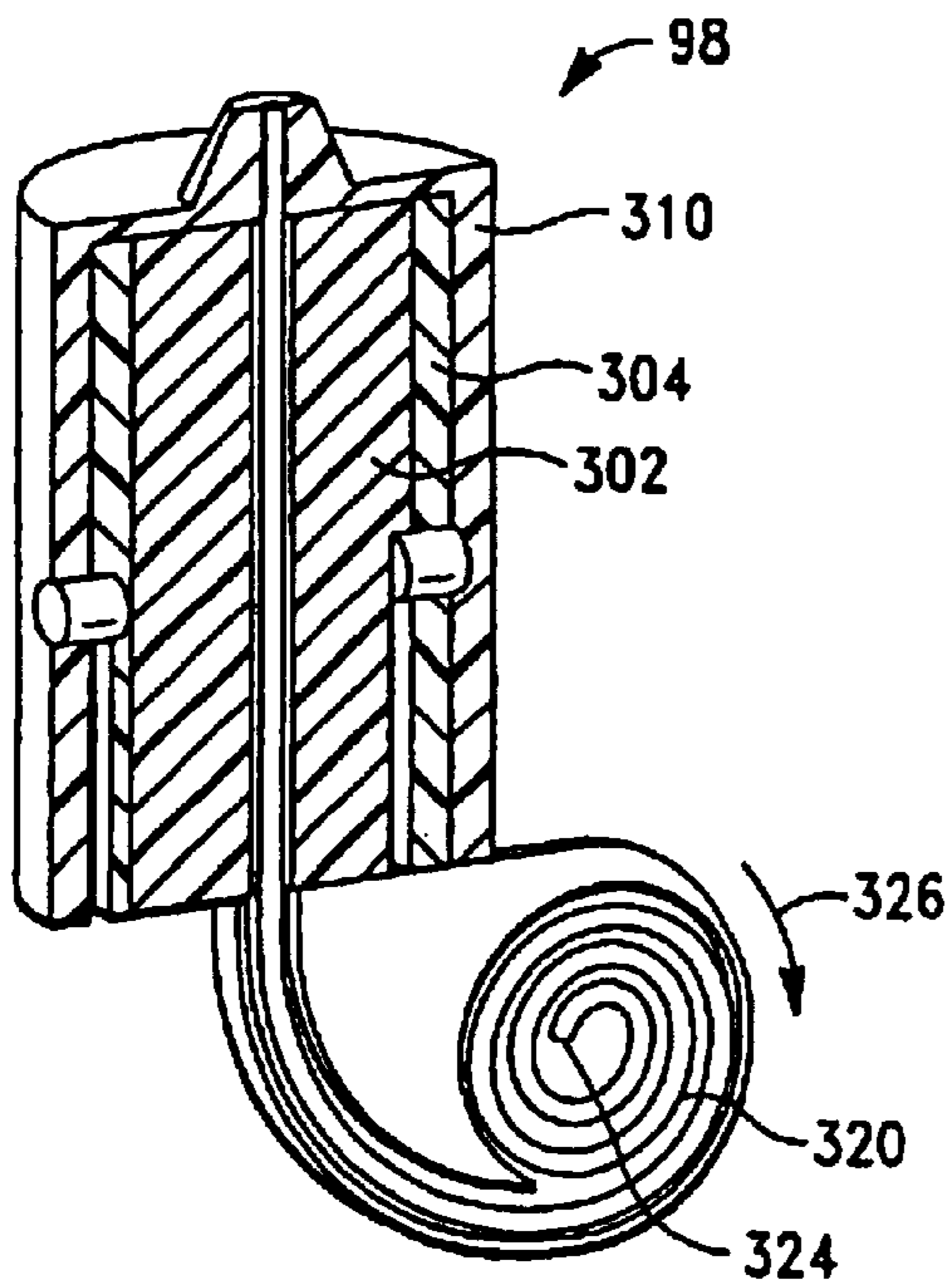
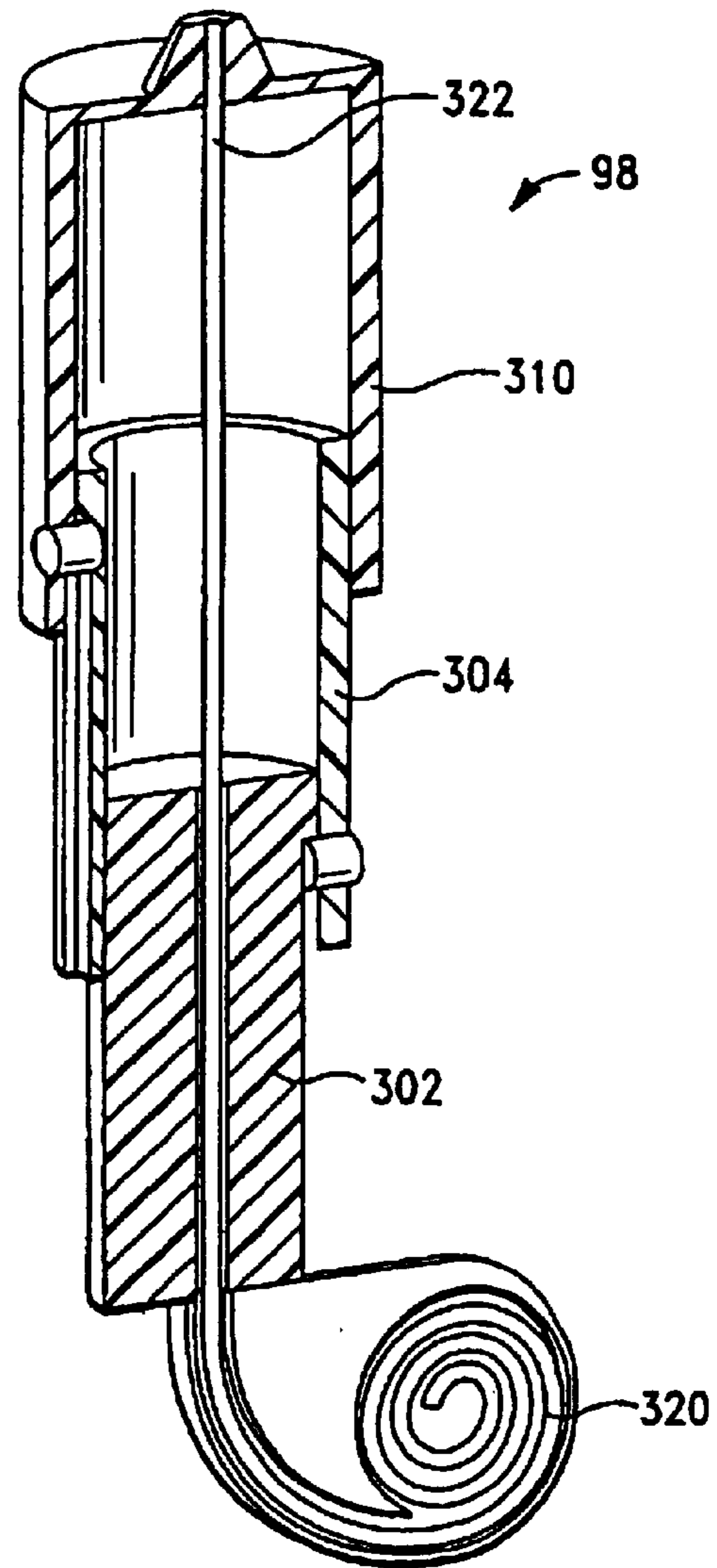

FIG. -35



**FIG. -36**



**FIG. -37**

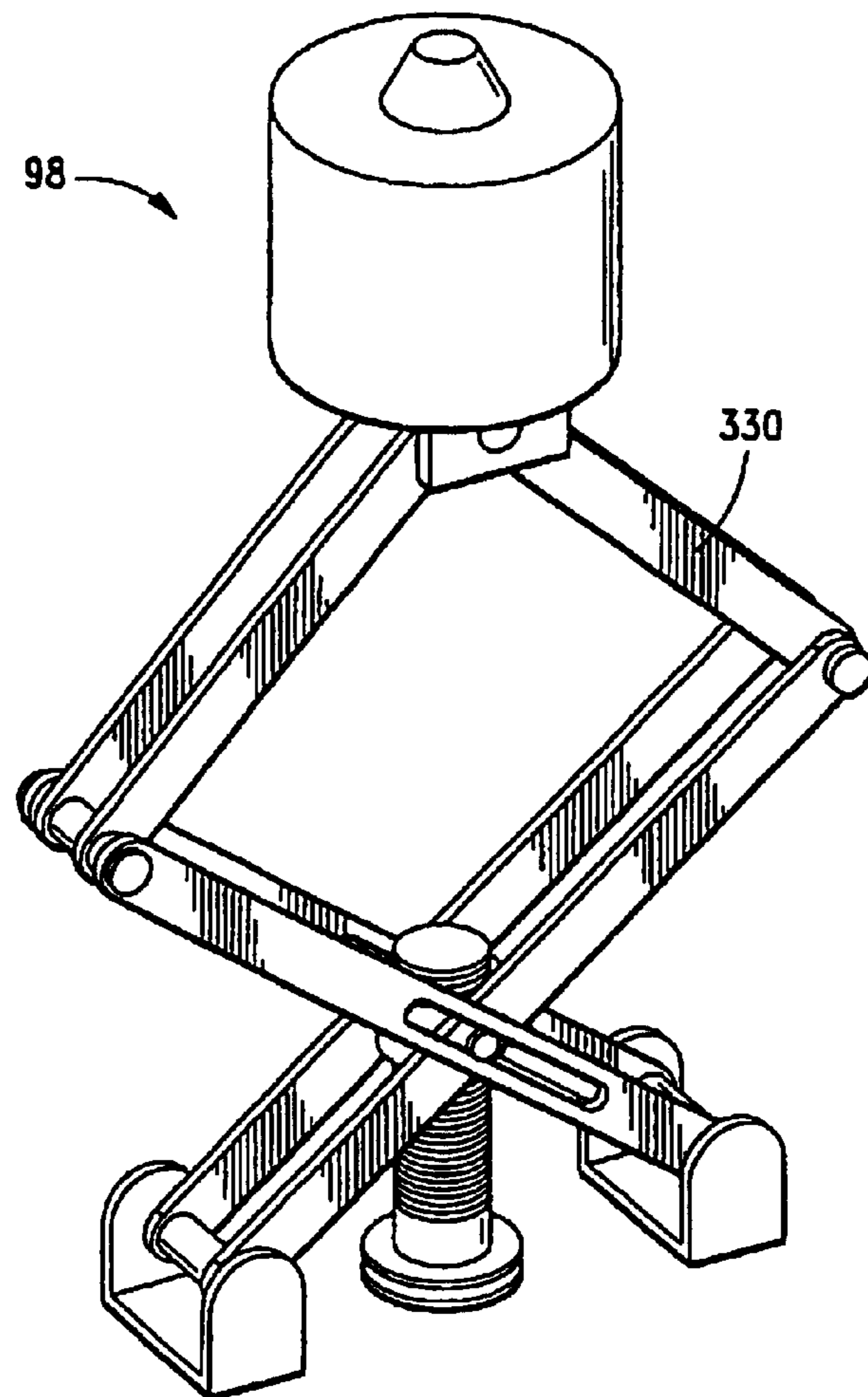
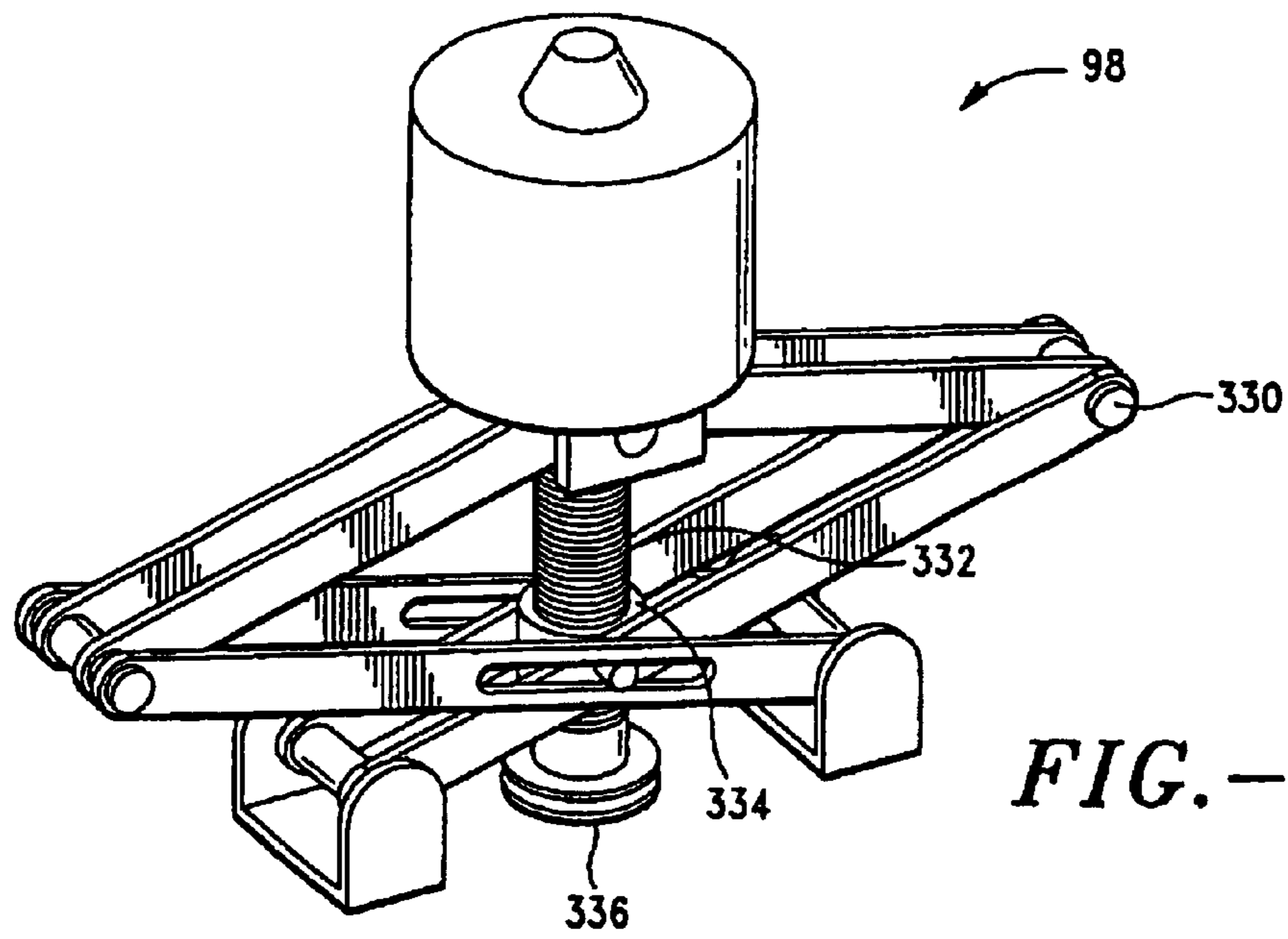

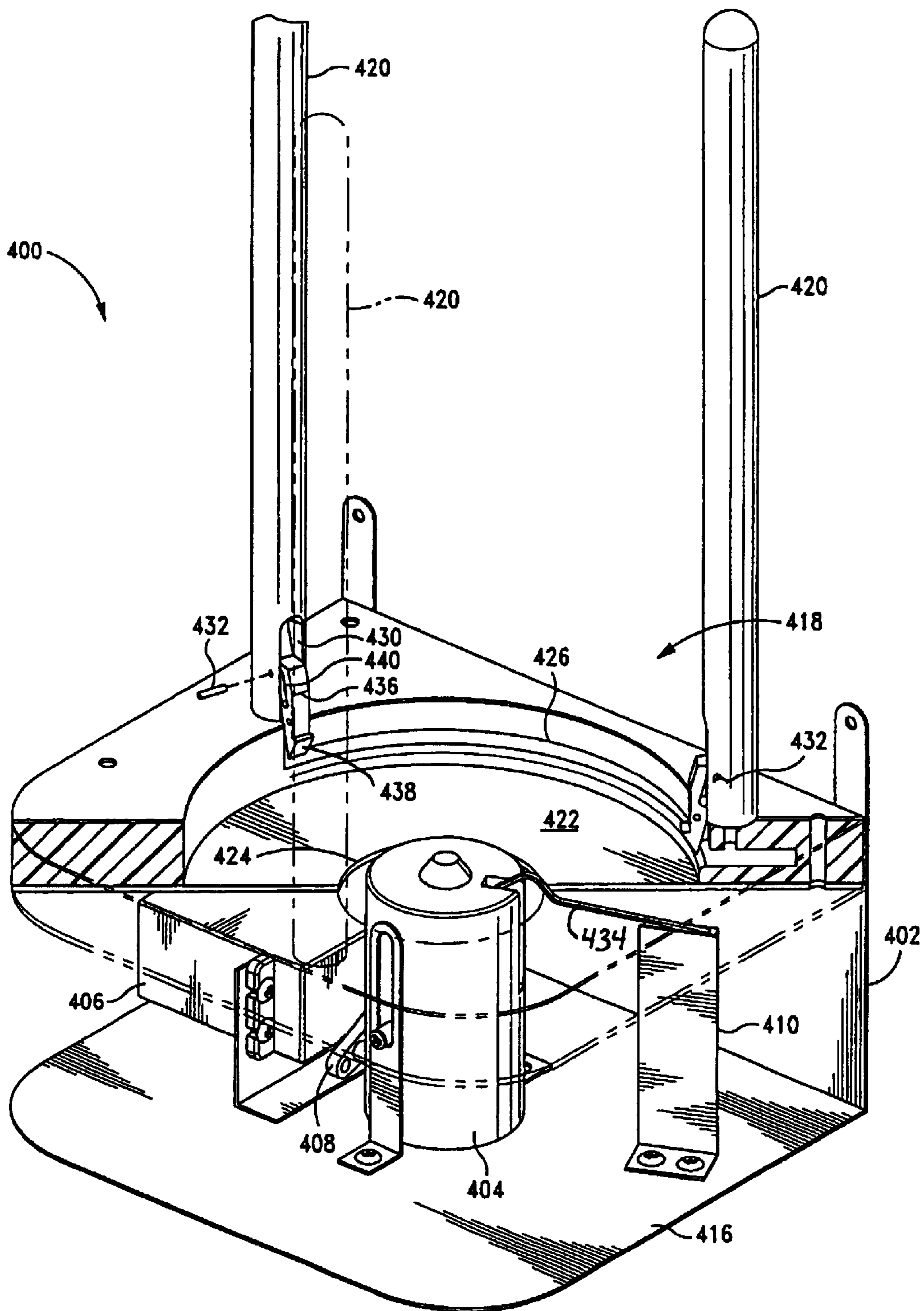

FIG.-40



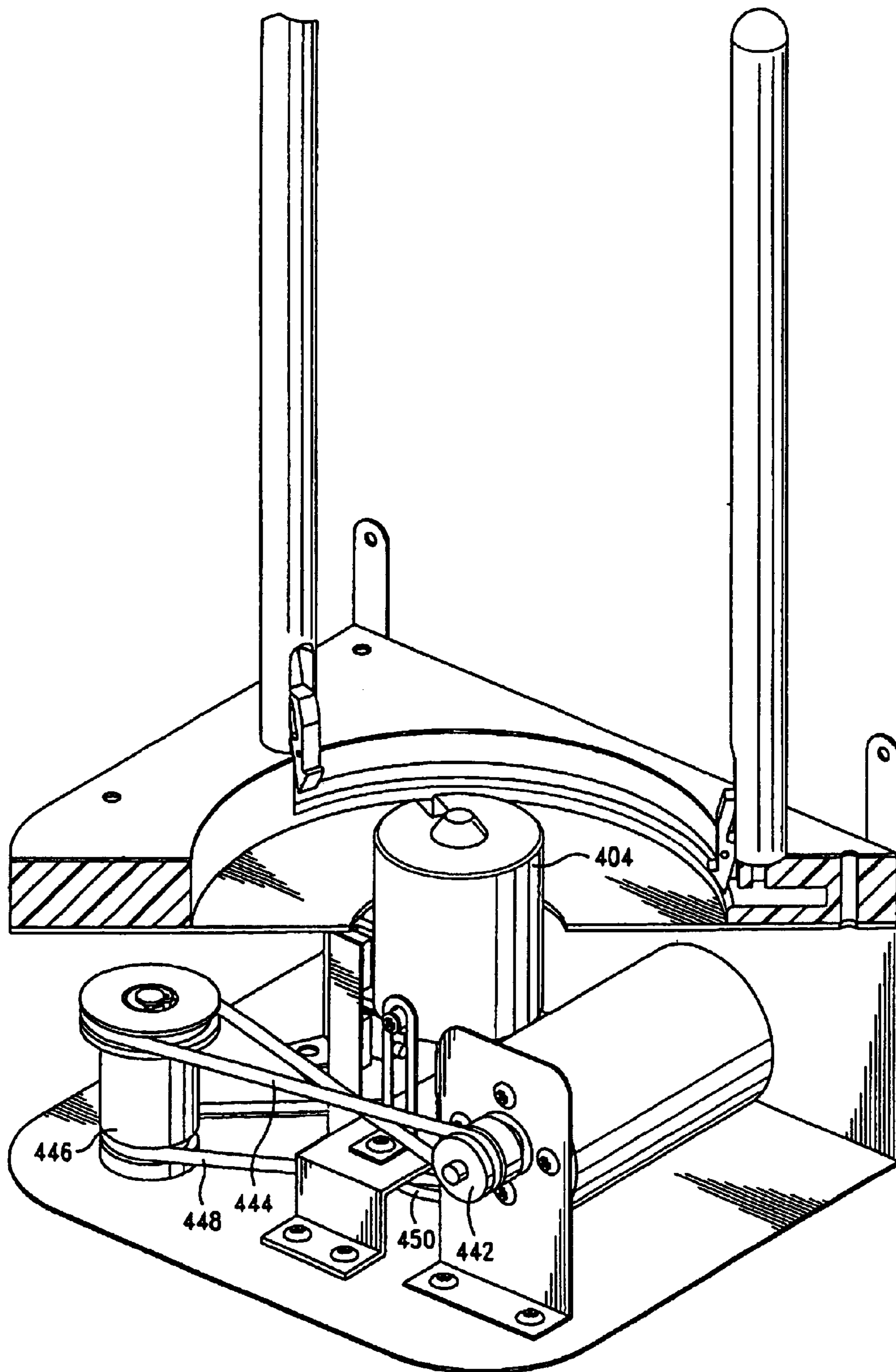

FIG.-41

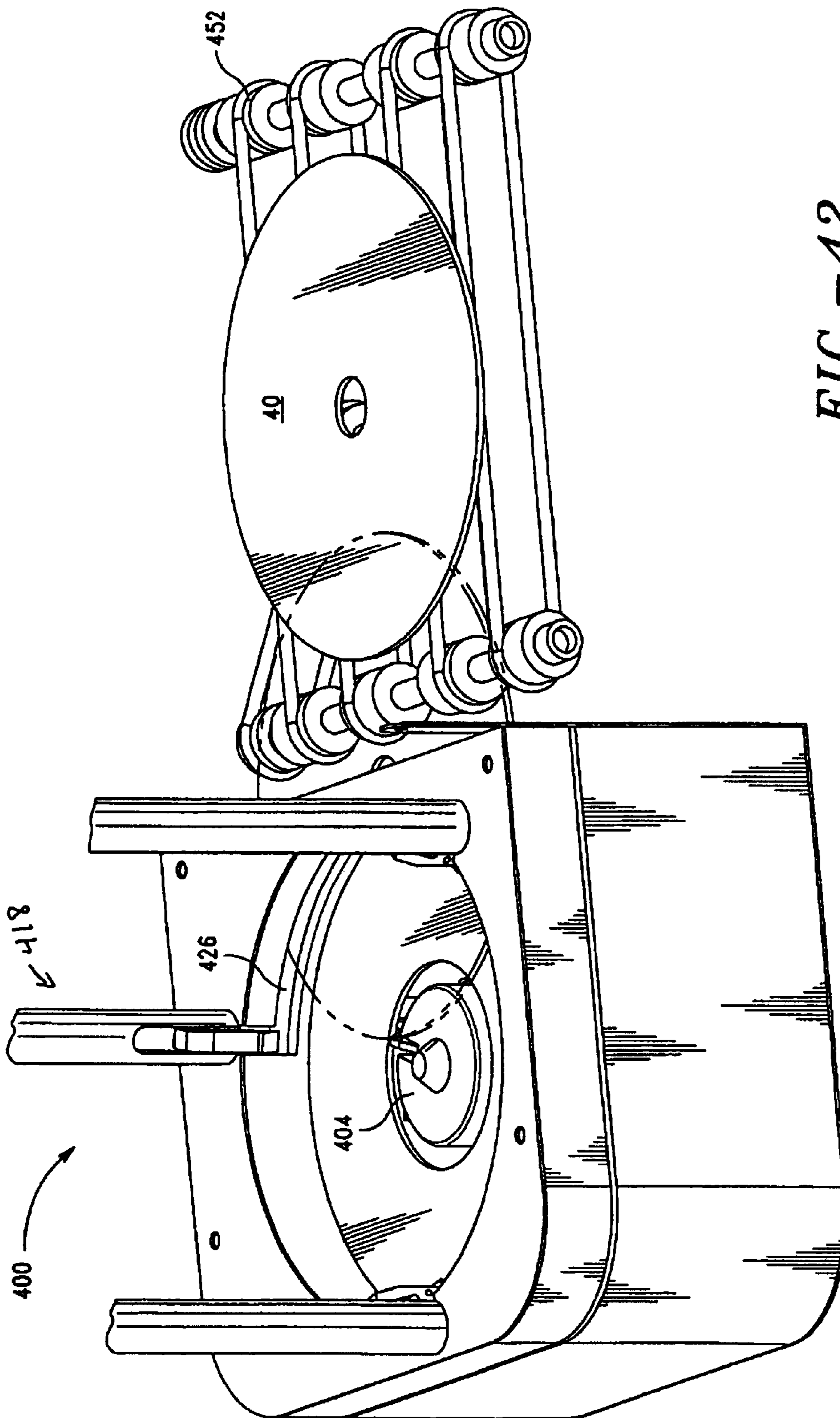
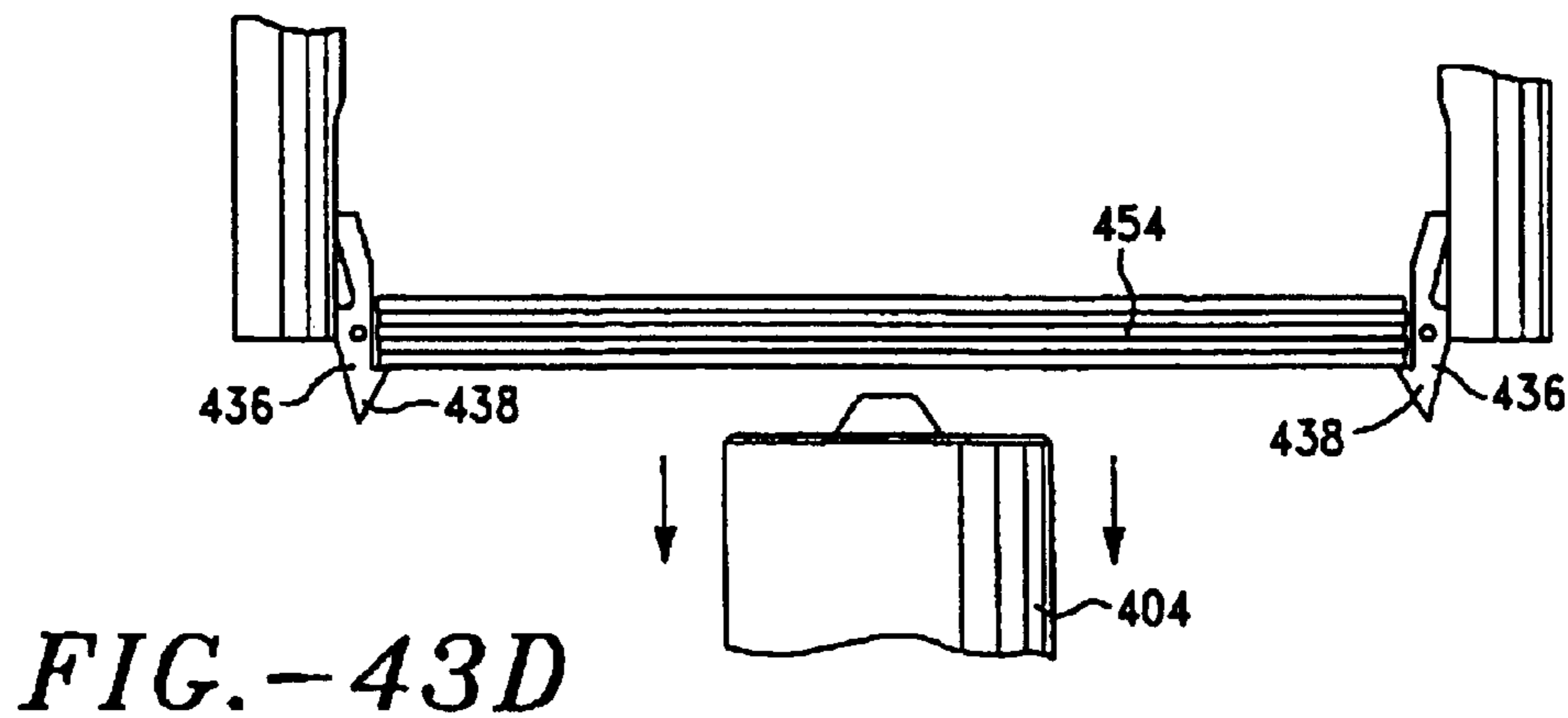
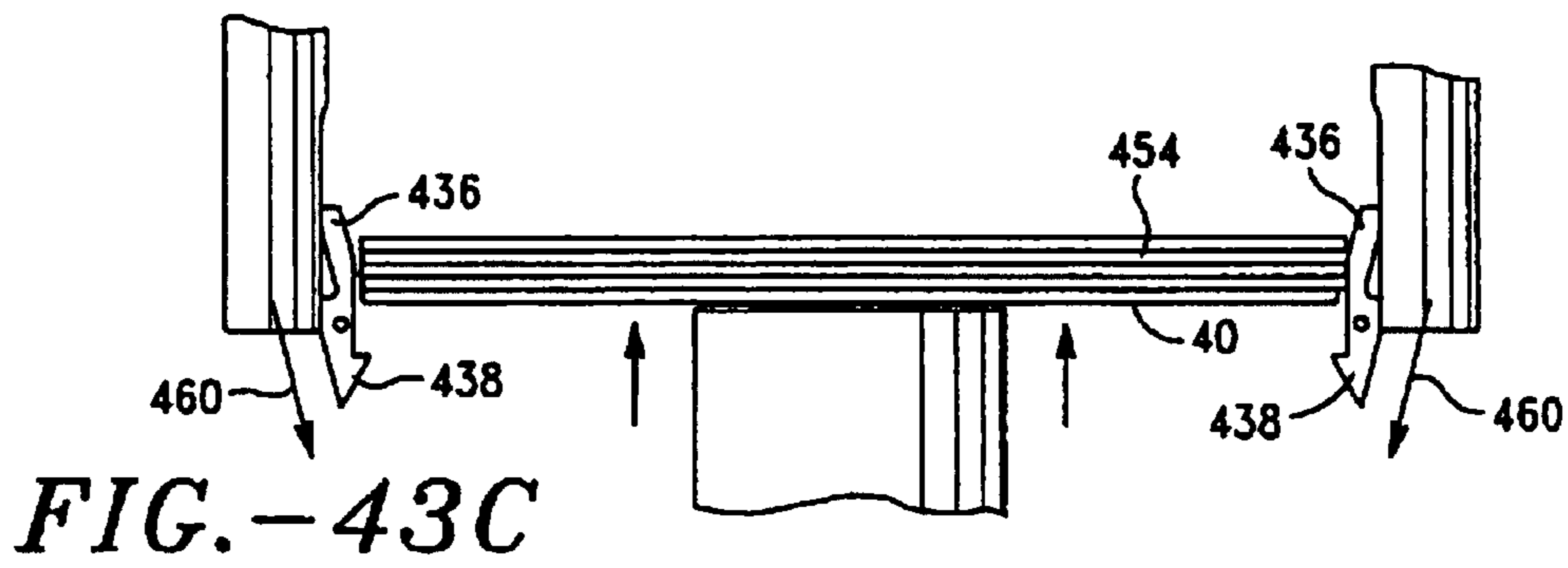
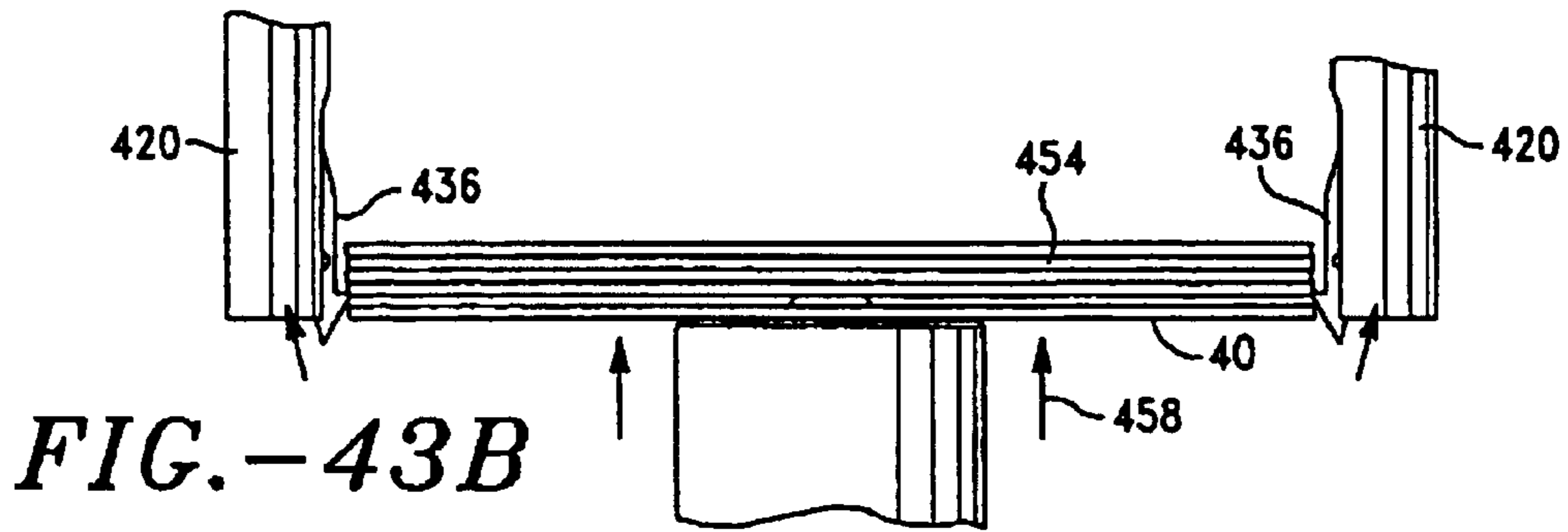
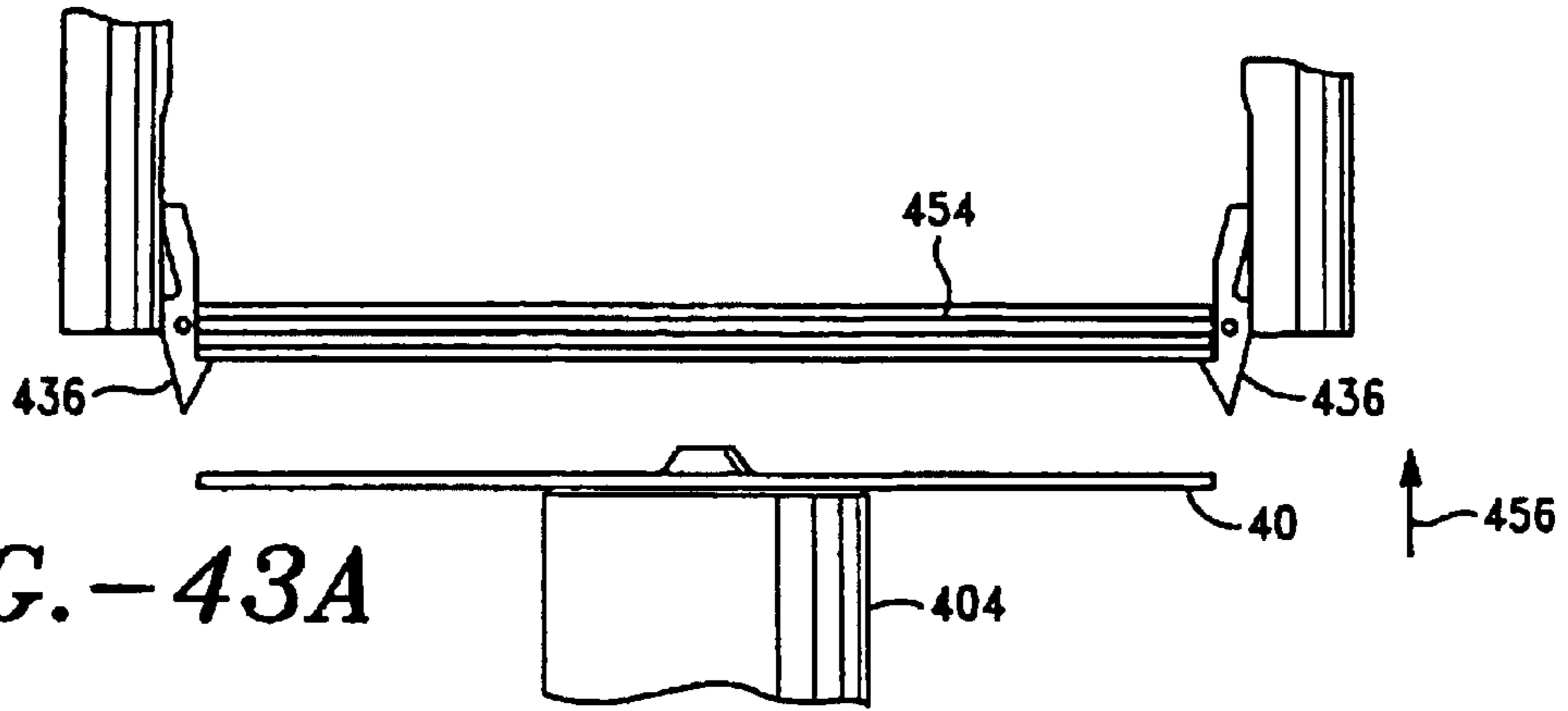

FIG. - 42



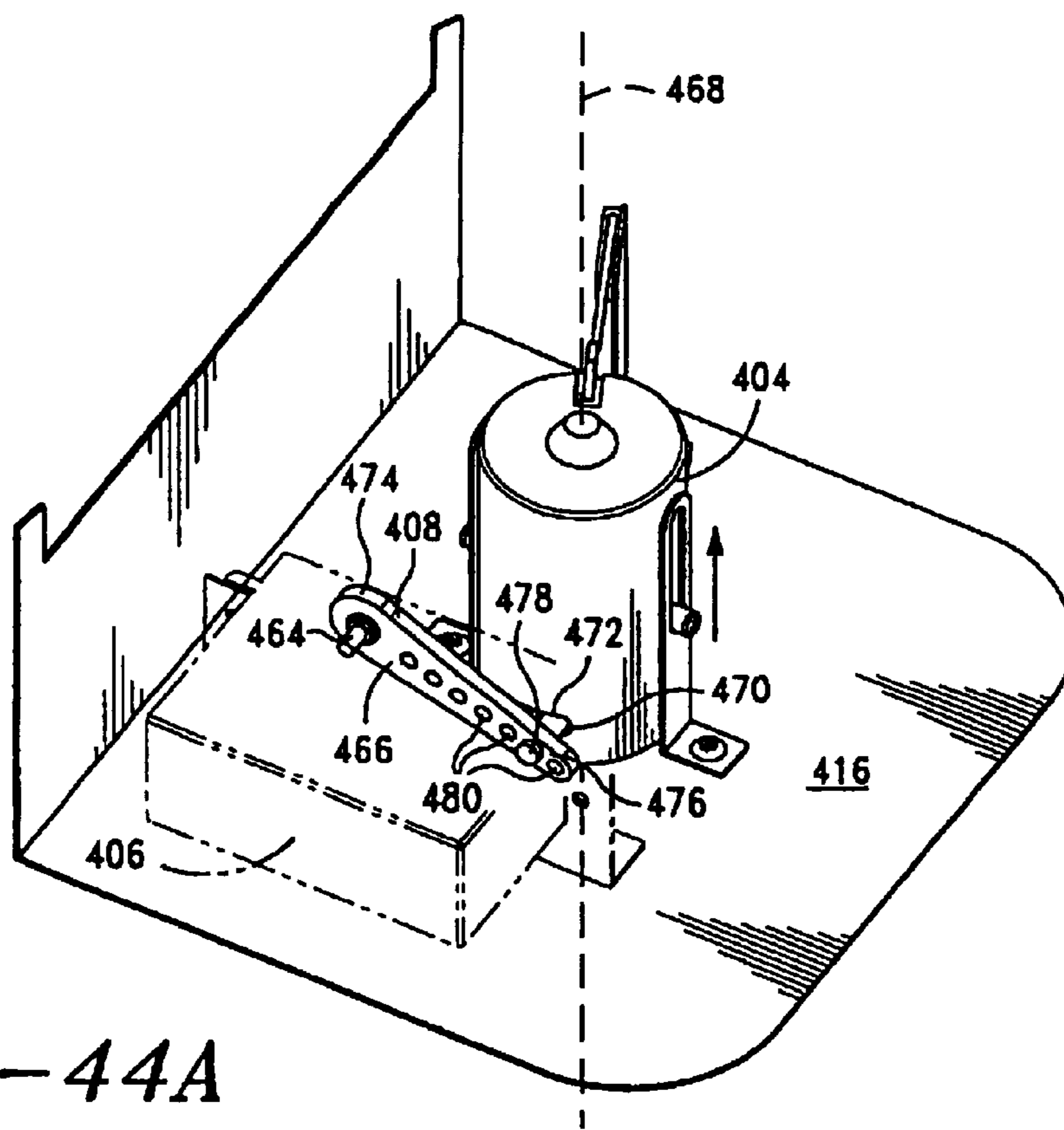

FIG. -44A

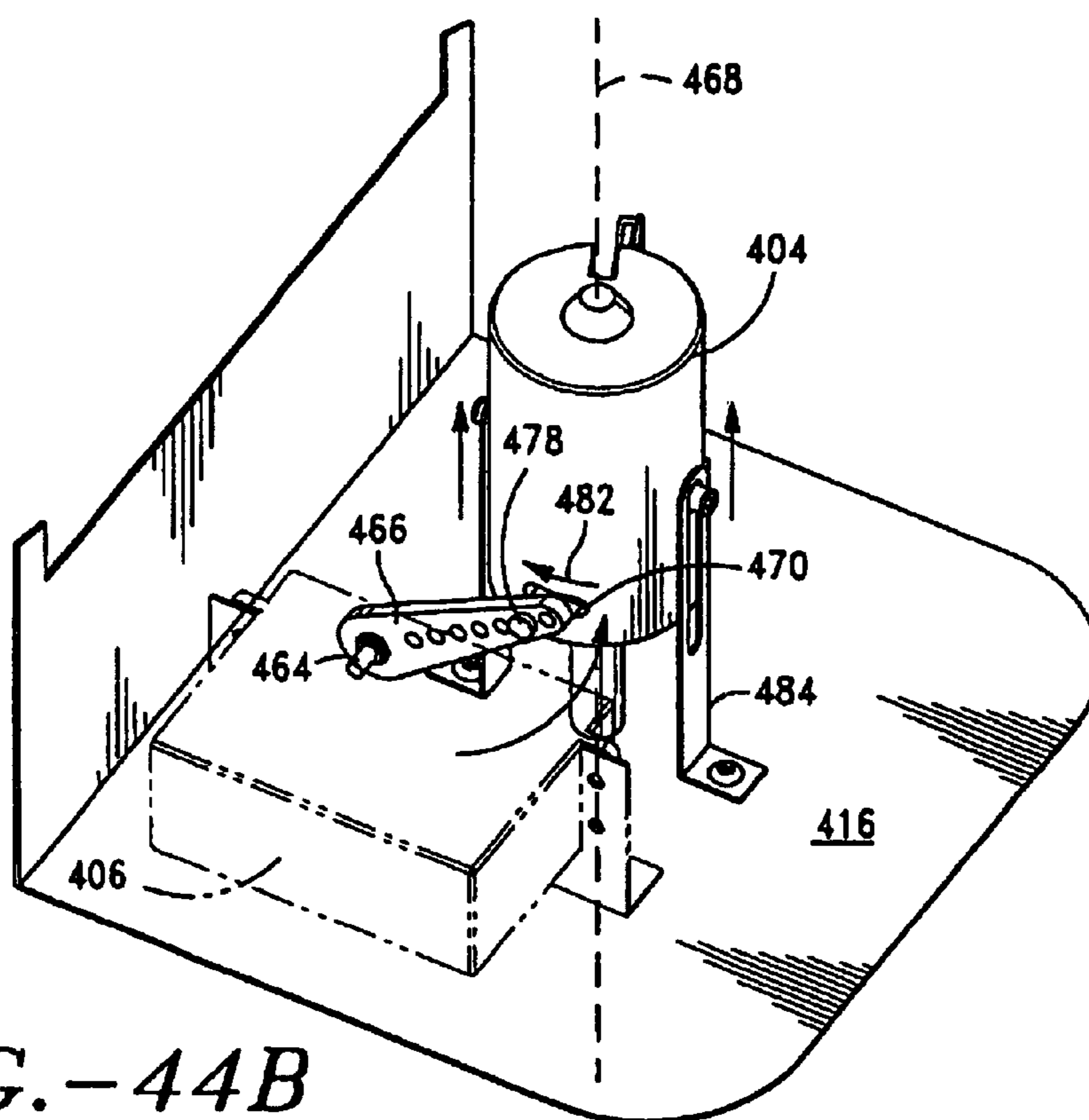
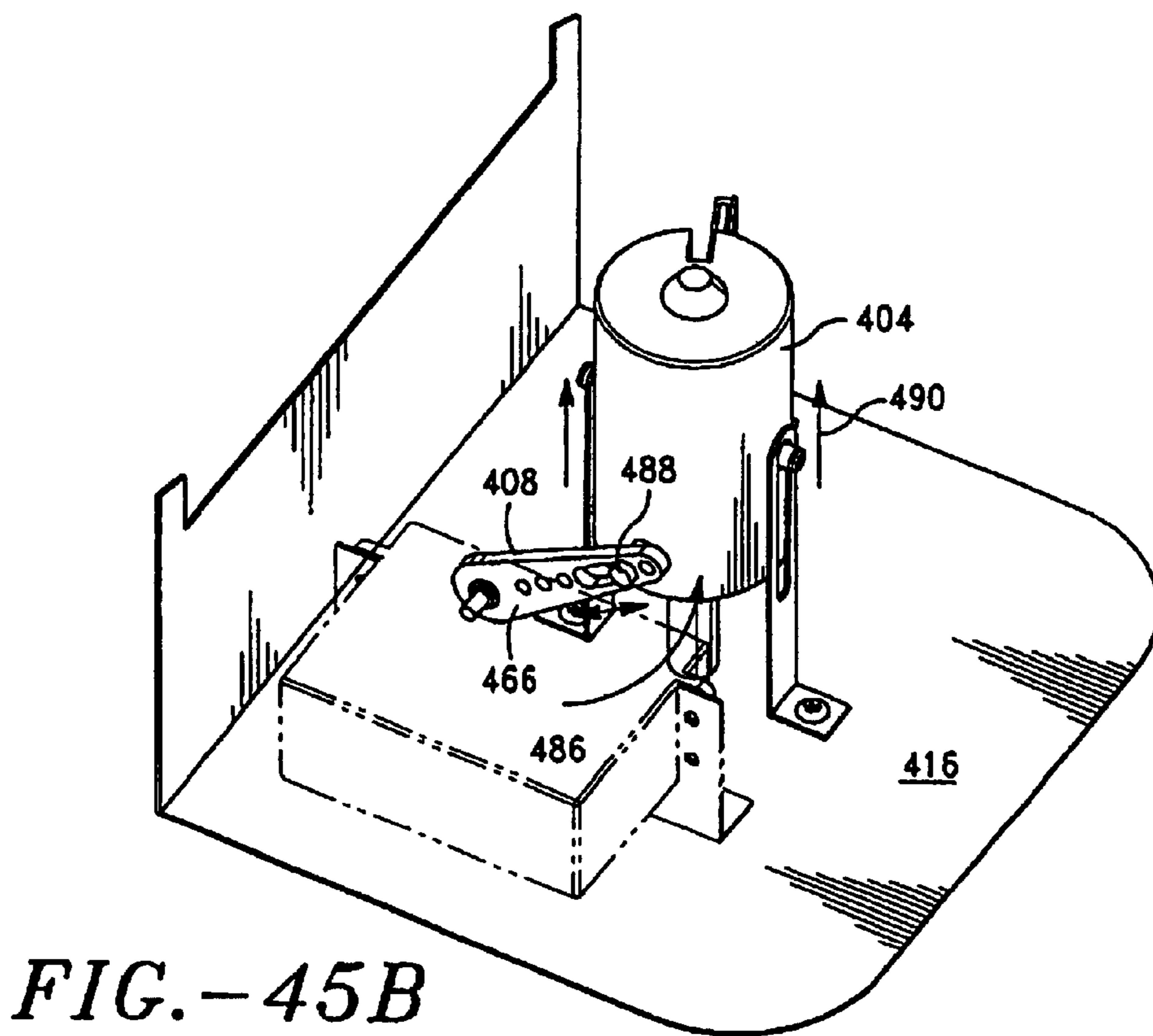
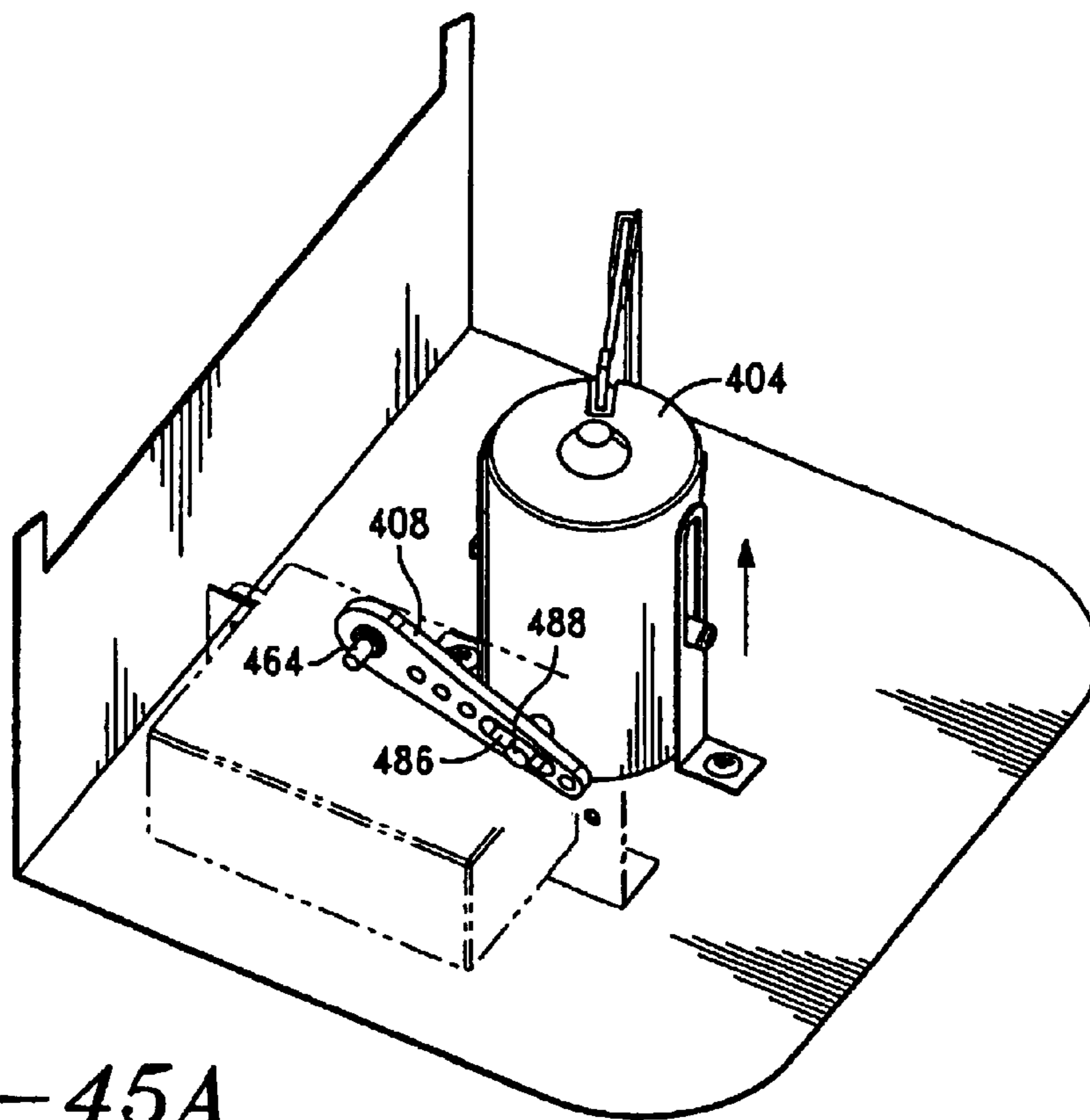
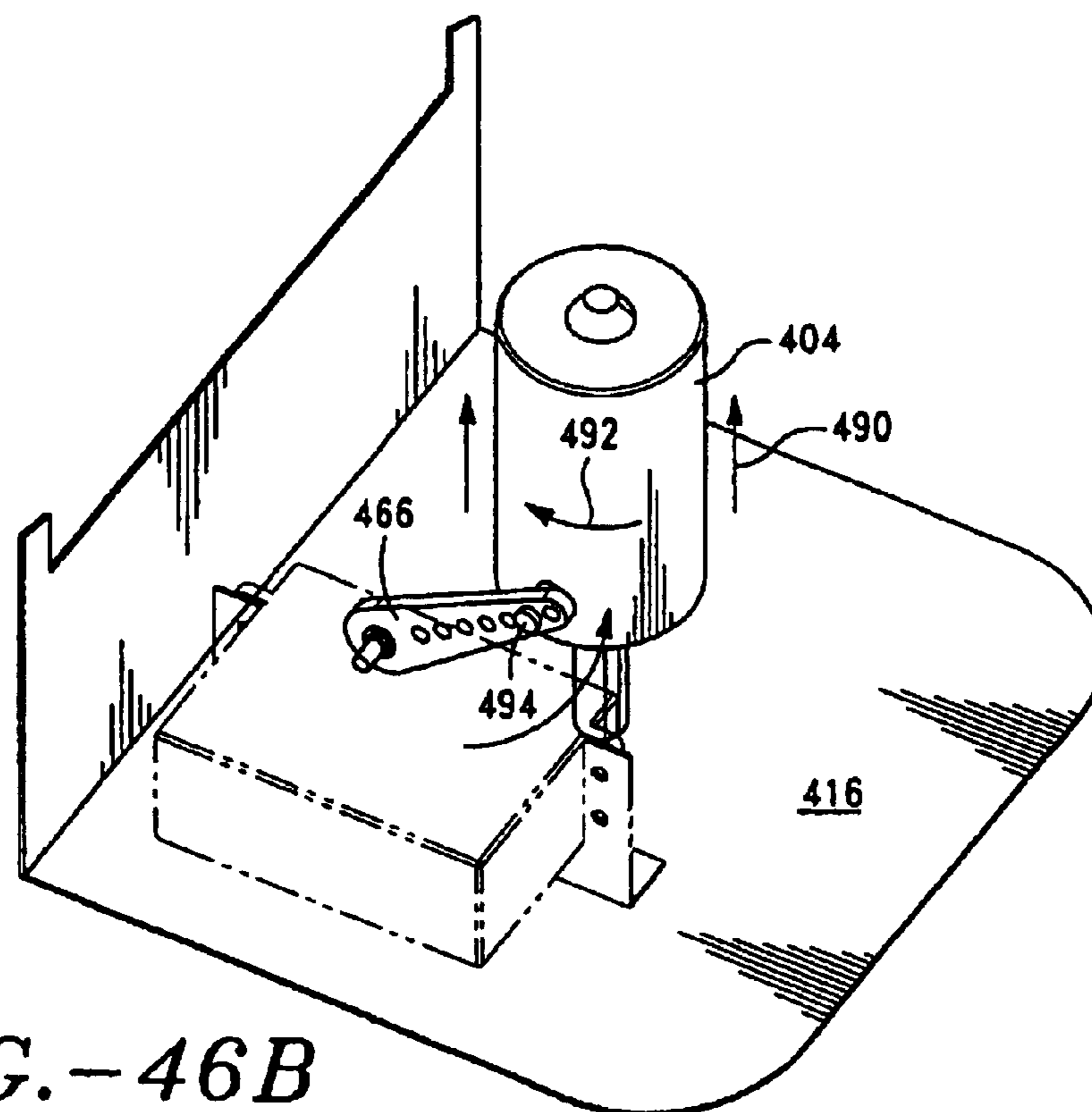
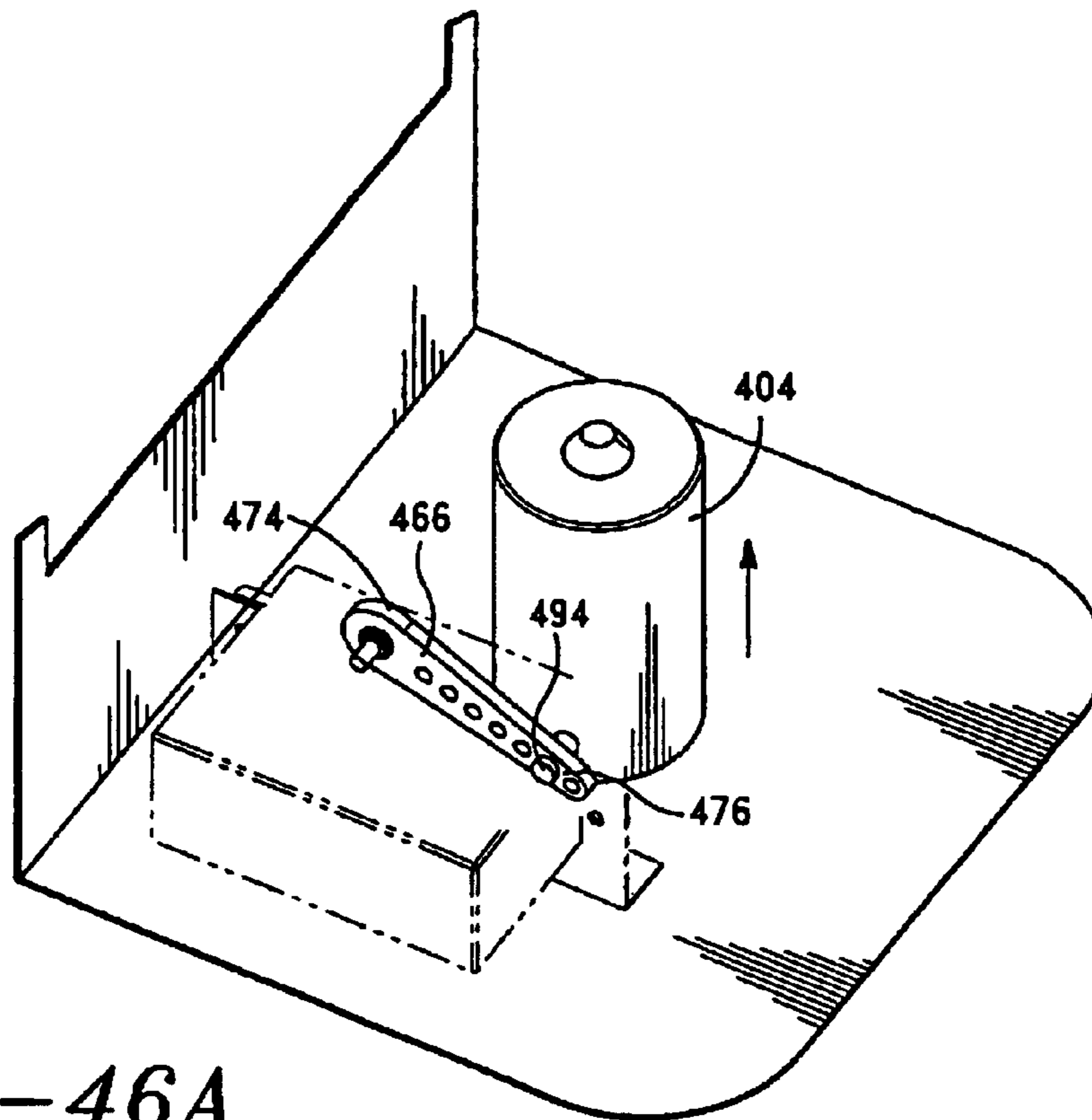
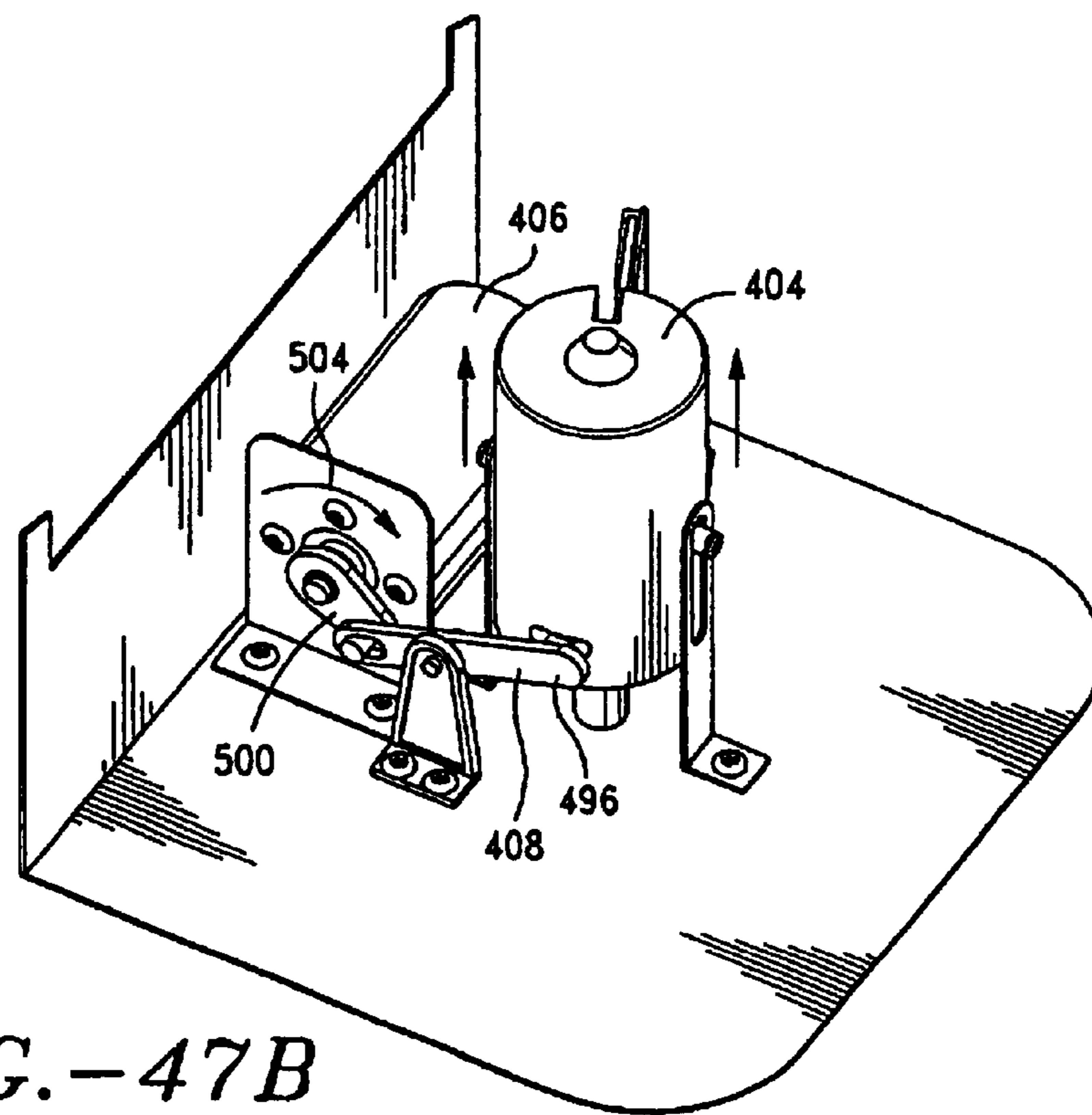
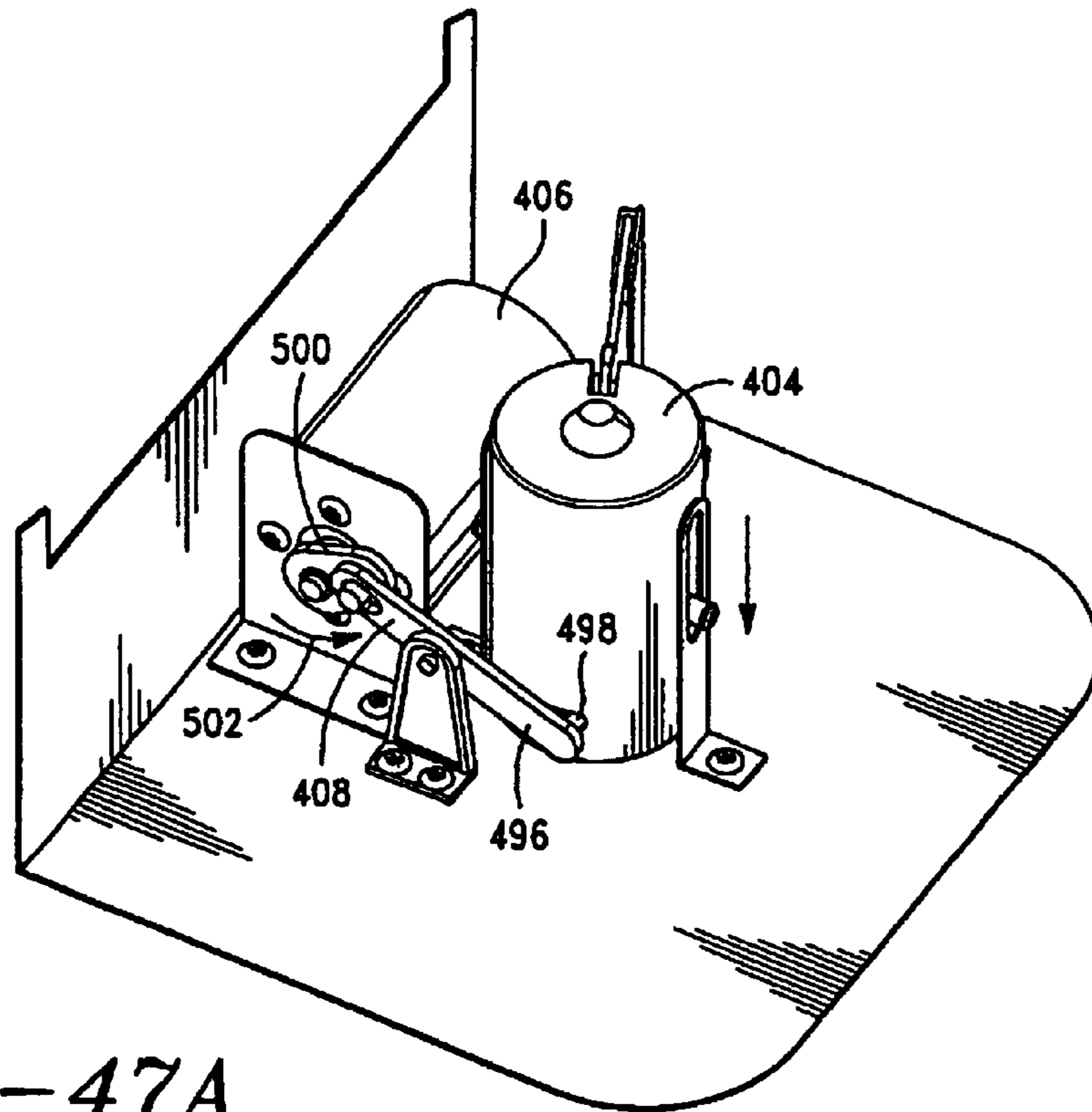

FIG. -44B







**MEMORY STORAGE DISK HANDLING  
SYSTEM HAVING A SERVO-DRIVEN  
ELEVATOR PIN**

**Matter enclosed in heavy brackets [ ] appears in the original patent but forms no part of this reissue specification; matter printed in italics indicates the additions made by reissue.**

CROSS-REFERENCE TO RELATED  
APPLICATIONS

This invention is a continuation-in-part of commonly assigned U.S. patent application Ser. No. 09/088,652, filed Jun. 1, 1998, now U.S. Pat. No. 6,337,842 B1.

FIELD OF THE INVENTION

This invention relates to memory storage disk handling systems and particularly to systems for handling, printing, duplicating or replicating compact disks, DVD's, and the like.

BACKGROUND OF THE INVENTION

Disk handling systems typically move a single disk between a stack of disks and a workstation. Such systems are particularly useful for handling memory storage disks such as CD's, DVD's and the like. Common memory storage disk handling systems include data writers, label printers, or both.

Some disk handling systems employ robotic arms to handle the disks. Others rely upon a gantry, or double gantry system. Many systems slide disks from the top of a stack, or robotically lift disks from the top of the stack. Sliding disks from a stack may scratch the surface of the disk. Robotically lifting the disks from the stack may prevent scratches when the robot functions properly.

One drawback to robotic arms and gantry systems is that they have moving parts, which wear. Wear can ultimately cause system misalignment and failure of a gantry or robotic arm over time. Accordingly, the known robotic arm and gantry systems should be carefully maintained.

While the typical memory storage device systems are effective, users may desire more throughput, i.e. an increase in the number of disks handled per hour, and less maintenance. Accordingly, what is desired is a reliable way of increasing the throughput of a typical disk handling system. What is also desired is a low-maintenance memory storage device handling system.

SUMMARY OF THE INVENTION

A memory storage disk handling system includes a housing with a hopper for holding disks. The system has an elevator pin, linkage and a servo motor mounted on the housing. The linkage attaches between the servo motor and the elevator pin. The servo motor rotates the arm to lift the elevator pin and deliver memory storage disks into the hopper. Preferably the linkage is a single arm and the servo motor causes the arm to cam against the elevator pin to lift the elevator pin.

The hopper defines a base and includes more than one pawl for holding lifted disks, thereby preventing the stacked disks from falling out of the hopper.

According to one aspect of the invention, the servo motor includes a shaft and the linkage includes a single arm. The arm has a fixed end and a moveable end. The fixed end is fixed with respect to the shaft and pivots when the shaft

rotates. The moveable end includes a cam surface that cams against the elevator pin to lift the elevator pin. Rotation of the servo motor shaft pivots the arm to lift the elevator pin.

The elevator pin includes an axis that aligns with the force of gravity. The elevator pin reciprocates in the direction of the axis to lift disks up and down.

According to an aspect of the invention, the stack retainer includes three posts oriented to surround lifted disks. Each post includes a hollow portion, and the pawls are mounted at least partially within the hollow portions of the posts. Accordingly when the elevator pin lifts a disk, the disk contacts the pawls and lifts the pawls into the hollow portions of the posts. As the disk further lifts past the pawls, the pawls slide to extend out of the hollow portions. The elevator pin then lowers, seating the disk on the pawls. This process repeats to up-stack a number of disk in the hopper.

BRIEF DESCRIPTION OF THE DRAWINGS

FIG. 1 is a perspective view of a disk duplication system in accordance with the present invention.

FIG. 2 is a perspective view of the turntable of FIG. 1.

FIG. 3 is an exploded perspective view of the disk dispenser of FIG. 1.

FIG. 4 is a perspective view of a portion of the dispenser of FIG. 3.

FIG. 5 is a perspective view of the disk dispenser of FIG. 3 and a portion of a feed hopper.

FIG. 6 shows a cutaway rear perspective view of the system of FIG. 1.

FIG. 7, FIG. 8, and FIG. 9 are side views, in sequence, of the elevator pin moving a disk from the turntable of FIG. 1.

FIG. 10, FIG. 11 and FIG. 12 correspond with FIG. 7, FIG. 8 and FIG. 9, respectively, and show partial cross-sectional views of the disk dispenser from a reversed angle.

FIG. 13, FIG. 14 and FIG. 15 show a cross-sectional side view of the elevator pin lifting a disk.

FIG. 16 and FIG. 17 show a disk clip in accordance with FIG. 15 and FIG. 14, respectively.

FIG. 18 is a perspective view of a disk recorder positioned in an operative arrangement with respect to the turntable and linkage mechanism in accordance with the present invention.

FIG. 19 is a perspective view of the drive linkage for the turntable of FIG. 1.

FIG. 20 is a perspective view of a disk recorder in combination with a disk printer.

FIG. 21 is a perspective view of the combination of FIG. 20 without a cover.

FIG. 22 is a perspective view of the writer tray, the printer tray and the elevator pin in accordance with the invention of FIG. 20.

FIG. 23, FIG. 24, FIG. 25, FIG. 26, FIG. 27 and FIG. 28 show a sequence of movement of the writer tray and printer tray of FIG. 22 in accordance with the present invention.

FIG. 29 shows a partially cutaway perspective view of disk duplication system having multiple recorders in accordance with the present invention.

FIG. 30 shows a perspective view of the turntable and multiple recorders of FIG. 29, stacked and aligned in accordance with the present invention.

FIG. 31 shows a perspective view of the turntable and multiple recorders stacked and aligned in a radial array in accordance with the present invention.



3

FIG. 32 and FIG. 33 show a perspective view of an elevator pin in accordance with the present invention in a retracted and extended configuration, respectively.

FIG. 34 and FIG. 35 show a perspective view of a variation of an elevator pin in accordance with the present invention in a retracted and extended configuration, respectively.

FIG. 36 and FIG. 37 show a perspective view of a variation of an elevator pin in accordance with the present invention in a retracted and extended configuration, respectively.

FIG. 38 and FIG. 39 show a perspective view of a variation of an elevator pin in accordance with the present invention in a retracted and extended configuration, respectively.

FIG. 40 shows a memory storage device handling system having a servo driven elevator pin.

FIG. 41 shows a linkage assembly includes pulleys and belts.

FIG. 42 shows a conveyor feeding a disk into a hopper via a lateral opening in the hopper.

FIGS. 43A, 43B, 43C, and 43D show the operation of hopper with a disk guide having pawls.

FIGS. 44A and 44B show the linkage assembly of the present invention having a cam pin that slides on a cam surface defined by the elevator pin.

FIGS. 45A and 45B show the linkage assembly of the present invention including a cam slot that slides with respect to the elevator pin.

FIGS. 46A and 46B show the linkage assembly of the present invention including an arm with two fixed ends.

FIGS. 47A and 47B show the linkage assembly of the present invention including a rocker arm.

#### DETAILED DESCRIPTION

FIG. 1 shows a disk duplication system, generally designated with the reference numeral 30. The system 30 includes a housing 32 with a cover 34, a turntable 36, and a disk dispenser 38. The turntable 36 includes several hoppers for feeding and accepting memory storage disks 40. The turntable 36 rotates to move the disks 40 along an arcuate path. The system 30 includes a sensor 33 mounted on a portion of the housing 32, adjacent the turntable 36.

The housing 32 encloses a CD recorder for writing data on disks. The disk dispenser 38 dispenses disks 40 into the recorder. When data writing is complete, the turntable 36 rotates and accepts the written disk in a selected hopper. Further rotation of the turntable 36 enables the disk dispenser 38 to dispense another disk into the CD recorder, repeating the data writing process.

The turntable 36 includes embedded magnets 35. The sensor 33 detects the magnets 35 to enable the system to recognize when the turntable 36 is in a desired rotational position with respect to the housing 32.

The disk dispenser 38 of the present invention is useful in conjunction recording data on memory storage disks such as compact disks, and duplicating compact disks. It can be appreciated, however, that a variety of media including optical or magnetic memory storage media may be dispensed and duplicated in accordance with the present invention. According to one variation of the invention, the housing 32 encloses a CD printer for printing indicia on disk surfaces and the disk dispenser 38 dispenses disks to the CD printer.

FIG. 2 shows the turntable 36. The turntable 36 includes a central post 52, outer posts 54, 56 and 58, a surface 42 defining three openings 43. The turntable has an axis 44, a generally designated feed hopper 46, accept hopper 48, and reject

4

hopper 50. The hoppers 46, 48 and 50 generally align adjacent a respective opening 43 to dispense or accept disks through each respective opening.

The disk dispenser 38 mounts on the turntable 36 adjacent one opening 43 to dispense disks through the turntable 36. The outer posts 54 cooperate with the central post 52 to define the hopper 46 which guides disks into the disk dispenser 38.

The central post 52 aligns with the turntable axis 44. The outer posts 54, 56 and 58 are positioned co-radially with respect to the turntable axis 44. The outer posts 56 and 58 cooperate with the central post 52 to surround the respective turntable openings 43 and to define the reject hopper 48 and accept hopper 50, respectively.

Although outer posts 54, 56 and 58 cooperate with the central post 52 to define the hoppers 46, 48 and 50 and provide a light weight structure to guide disks, one can appreciate that hoppers may assume any of a number of configurations. A cylindrical wall may define a hopper, for example. Also for example, a helical coil, or by another structure having a lightweight design could define the hopper.

FIG. 3 shows an exploded view of the disk dispenser, generally designated 38. The disk dispenser 38 includes an upper guide 60, a lower guide 62 and a plate 64. The lower guide 62 includes a spring 68, a rim 72, a support lip 74, an opposing edge 75, and fasteners 76. The plate 64 includes an arced edge 71. The arced edge 71 defines an inner periphery 73. The inner periphery 73 defines an opening for surrounding a disk. Preferably, the inner periphery 73 is circular for circumscribing a disk. The inner periphery 73 is configured with a beveled edge for separating single disks from a stack of disks.

The upper guide 60, the lower guide 62 and the plate 64 each define a generally circular opening to enable a disk to pass through the disk dispenser 38. Each opening is sized for a disk to pass through when the disk parallels the plate 64. The upper guide 60 and the lower guide 62 are axially offset from each other so that a portion of the rim 72 of lower guide 62 stops disks which may fall through the upper guide 60 towards the lower guide 62. The opposing edge 75 diametrically opposes the support lip 74. The support lip 74 cooperates with the opposing edge 75 to hold a disk on the lower guide 62. The plate 64 slidably mounts between the upper guide 60 and the lower guide 62 to selectively pass disks stopped by the lower guide 60 through the lower guide 62.

The pin 70 extends between the lower guide 62 and the upper guide 60 to retain the spring 68. The plate 64 includes a pair of holes 78, which align with respective fasteners 76. The fasteners 76 extend through the upper guide 60, the plate 64 and the lower guide 62 to hold the upper guide 60 and the lower guide 62 together. The fasteners 76 retain the plate 64 between the upper guide 60 and the lower guide 62. The fasteners 76 align the plate 64 relative to the upper guide 60 and the lower guide 62 when the plate 64 slides.

The lower guide 62 includes a groove 71. The spring 68 is a coil spring having two ends. The spring 68 lies in the groove 71. The pin 70 inserts perpendicularly into the groove 71. Accordingly, one end of the spring 68 contacts the pin 70. The spring 68 biases the plate 64 in a desired position. According to one aspect of the invention, the spring 68 offsets the plate 64 from the lower guide 62 to enable the lower guide 62 to support a disk.

The plate 64 has a shoulder with an edge 80. The edge 80 contacts the other end of the spring 68. The spring 68 biases the plate 64 into a desired position relative to the lower guide

5

62. When the plate 64 slides towards the pin 70, the spring 68 dampens movement of the plate 64. The plate 64 has a generally uniform thickness "t". The thickness "t" approximates the thickness of an individual disk to be dispensed so that when the plate 64 slides, only one disk is dispensed.

FIG. 4 is a perspective view of the plate 64 and the lower guide 62. The plate 64 reciprocates with respect to the lower guide in the direction of the arrows 86. The lower guide 62 opening defines an axis 82. The spring 68 biases the plate 64 so that the plate opening is axially offset from the lower guide opening. Offsetting the plate 64 opening from the lower guide 62 opening enables the support lip 74, in cooperation with the opposing edge 75, to hold a disk on the lower guide 62. The plate 64 circumscribes a disk when the disk is on the lower guide 62. The plate 64 slides towards the springs 68 to dispense a disk through the lower guide 62 opening. The springs 68 reciprocate the plate 64.

FIG. 5 is a perspective view of the disk dispenser 38 attached to the feed hopper 46. The feed hopper 46 is configured with a reinforcement plate 88, which bolts to the upper guide 60. The outer posts 54 mount on the reinforcement plate 88. Accordingly, the feed hopper attaches to the disk dispenser. The reinforcement plate 88 inhibits flexion of the disk dispenser 38 while supporting the feed hopper 46 (see FIG. 2).

The upper guide 60 has an opening with an axis 83. The axis 82 of the lower guide 62 opening is axially offset from the axis 83 of the upper guide 60 opening.

FIG. 6 shows a cutaway rear perspective view of the housing 32. The housing 32 includes a motor 100, a mechanical linkage 102, the elevator pin 98 and an arm 104. The arm 104 and the elevator pin 98 are connected via the mechanical linkage 102 to the motor 100. The motor 100 actuates the mechanical linkage 102 to cause the arm 104 to slide the plate 64 and to lift and lower the elevator pin 98. Movement of the linkage 102 and rotation of the turntable 36 dispense disks, one at a time, from the dispenser 38 onto the elevator pin 98. Movement of the linkage 102 may also insert disks, one at a time, through the opening 43 in the turntable 36 when the turntable 36 rotates.

According to one aspect of the invention, the elevator pin 98 is a single unit. According to another aspect of the invention, the elevator pin 98 has multiple components, which extend and retract.

FIG. 7 shows a side view of the disk dispenser 38, the turntable 36 and the linkage 102. The motor 100 actuates the linkage 102. The linkage 102 elevates the elevator pin 98 towards the turntable 36 and moves the arm 104. The arm 104 moves towards the plate 64 of the disk dispenser.

FIG. 8 shows further movement of the linkage 102. The arm 104 presses against the plate 64 to slide the plate 64. Sliding the plate 64 relative to the upper guide 60 and the lower 62 guide causes the dispenser 38 to drop the disk 40 onto the elevator pin 98.

FIG. 9 shows further movement the linkage 102. The elevator pin 98 retracts from the dispenser 38. The arm 104 simultaneously withdraws from the dispenser 38. The elevator pin 98 lowers the dispensed disk 40 away from the dispenser 38.

A single elevator pin cycle is completed when the elevator pin 98 retracts and the arm 104 withdraws. At this point in the cycle, the turntable 36 rotates. Rotation of the turntable 36 enables a subsequent cycle of the elevator pin 98 to lift the disk 40 back onto the turntable 36, for example.

FIG. 10 shows the arm 104 moving towards the plate 64. The support lip 74 and the opposing edge 75 of the lower

6

guide 62 support the disk 40. The elevator pin 98 moves towards the dispenser 38 and the arm 104 moves towards the plate 64. Preferably, the upper guide 60 holds from 4–6 disks in parallel with the plate. The three hoppers are each adapted to hold between 100–150 disks.

The central post 52 of the feed hopper 46 includes a recessed portion 130, an extended portion 132 and an adjustable set screw 133. The recessed portion 130 is adjacent the upper guide 60 to feed disks, in horizontal alignment with the plate 64, from the feed hopper 46 to the upper guide 60. The set screw 133 rotatably extends through the central post 52 to adjust the distance at which the extended portion 132 extends from the central post 52 and insures proper feeding of disks from the feed hopper 46 to the upper guide 60.

The extended portion 132 angles disks stacked in the feed hopper 46 with respect to the plate 64. Angling disks within the feed hopper 46 minimizes forces caused by disk weight on the disk dispenser 38, and particularly on the plate 64. Minimizing such forces enables multiple disks to be stacked in the feed hopper 46 and optimizes reliability of the disk dispenser.

FIG. 11 shows the arm 104 contacting the plate 64. The disk 40 has two opposing edges 136 and 138. The arm 104 contacts the plate 64 to slide the plate 64 in the direction of the arrow 90. The plate 64 urges the edge 136 of the disk 40 off of the edge 75 of the lower guide 62. Reciprocation of the plate 64 urges the other edge 138 of the disk 40 off of the support lip 74 so that the disk 40 falls from the lower guide 60 onto the elevator pin 98.

FIG. 12 shows the arm 104 withdrawn from the plate 64. The plate 64 automatically reciprocates as the arm 104 withdraws. The plate 64 guides the next disk 105 onto the lower guide 62. Movement of the next disk 105 onto the lower guide 62 causes another disk 107 to fall from the hopper into the upper guide 60.

FIG. 13 shows the elevator pin 98 extending to lift the disk 40 towards the turntable 36 from below the opening 43 of the accept hopper 48. The turntable defines the opening 43 to enable disks to pass into the accept hopper from beneath the turntable 36. The turntable 43 includes a periphery 110 surrounding the opening 43. A plurality of disk clips 108 mount on the periphery 110. The disk clips 108 function to allow the disk 40 to move through the turntable 36 into the accept hopper in only one direction, in the direction of the arrow 106.

FIG. 14 shows the elevator pin 98 lift the disk 40 in the direction of the arrows 106 above the turntable 36. The elevator pin 98 passes through the turntable 36 with the disk 40. The disk 40 lifts the disk clips 108 as the disk 40 passes through the turntable 36. The disk 40 has an outer edge 114. The disk clips have ends 120. As the elevator pin 98 passes through the turntable, the outer edge 114 of the disk contacts the ends 120 of the disk clips 108.

The ends 120 of the disk clips 108 are angled to contact primarily the outer edge 114 of the disk 40. The angled ends 120 align the disk 40 in parallel with the turntable 36 as the disk passes through the turntable 36. This alignment insures that the disk 40 will not flutter on the elevator pin 98 when the elevator pin 98 extends to lift the disk 40 through the turntable 36. The elevator pin 98 retracts to place the disk 40 on to the disk clips 108.

FIG. 15 shows the elevator pin 98 reciprocating in the direction of the arrows 112. The disk clips 108 extend radially towards the center of the opening 110. The elevator pin drops the disk 40 on the disk clips 108 so that the disk clips support the outer edge 114 of the disk 40. The disk clips 108

align with the turntable 36 to support the disk 40 on the turntable 36. The disk clips 108 are configured, having strength enough to support a stack of disks.

Repeating the process shown in FIG. 13, FIG. 14 and FIG. 15 that elevator pin stacks multiple disks on the disk clips 108 via the turntable opening 110 from beneath the turntable 36. To enable the disk clips 108 support a stack of disks, the elevator pin 98 is strong enough to lift the stack of disks supported when the elevator pin 98 lifts a disk through the turntable 36.

FIG. 16 shows a disk clip 108. The disk clip 108 includes a hinge 116, a spring 118 and the angled end 120. The spring 118 includes a strip of resilient material, which covers a portion of the disk clip 108 to bias the disk clip 108 in the configuration shown.

FIG. 17 shows the disk clip 108 rotated about the hinge 116. The disk clip 108 extends at an angle with respect to the hinge 116. The spring 118 flexes and the beveled edge 120 aligns perpendicularly to the hinge 116 and to the turntable surface, see FIG. 13.

FIG. 18 shows the turntable 36, a recorder 122, a hard drive 124, the elevator pin 98, and the mechanical linkage 102. The recorder 122 includes a tray 126. The tray 126 automatically extends from the recorder 122 to interpose a disk between the elevator pin 98 and the turntable 36, or to catch a disk, which is dispensed from the disk dispenser 38.

The tray 126 includes an opening 128 to enable the elevator pin 98 to extend through the turntable 36, via the tray 126. The hard drive 124 couples with the recorder 122 to deliver data to be written. A controller including a circuit board within the housing regulates operation of the hard drive 124, the recorder 122, the linkage 102 and the turntable 36.

According to one aspect of the invention, the recorder 122 is a Compact Disk Recorder, a DVD recorder, or the like. Preferably, the housing 32 of FIG. 1 encloses the recorder 122, the hard drive 124, the pin 98 and the linkage 102. The recorder 122 in combination with the disk dispenser 38, turntable 36 and the elevator pin 98 enables duplication of memory storage disks.

FIG. 19 is a perspective view of a portion of the linkage assembly, generally designated 140, which rotates the turntable 36 in accordance with the present invention. The drive linkage assembly 140 mounts on a portion of the housing 32. The assembly 140 includes a motor 142, belts 144, and pulleys 146. The belts 144 and pulleys 146 operate to selectively rotate the turntable 36 at a desired rate.

FIG. 20 shows a disk duplicating and printing apparatus 200. The apparatus 200 includes a housing 202, which encloses a disk recorder and a disk printer. The apparatus 200 includes a turntable 36 having a disk dispenser 38, and a transparent cover 204.

The transparent cover 204 is split and includes hinges 206 to enable the cover 204 to open and close without requiring removal of the cover from the housing. The cover 204 is transparent to enable inspection of the disk duplicating and printing apparatus 200 during operation.

While the turntable and disk dispenser are shown in conjunction with a recorder and a printer, it can be appreciated that the turntable and dispenser can be used in any of a number of operations which are performed on memory storage disks, including cleaning, polishing, re-recording, packaging, and reading, etc.

FIG. 21 shows the apparatus 200 having a frame 208, a motor 210, a disk recorder 212 and a disk printer 214. The

disk recorder 212, disk printer 214 and motor 210 mount on the frame 208. The motor 210 rotates the turntable 36 to move disks between the turntable 36, the disk recorder 212 and the disk printer 214. The motor 210 also actuates the disk dispenser 38. The printer 214 has a tray 220, which extends and retracts. The printer 214 includes an ink jet cartridge 216, which reciprocates in the direction of the arrows 218 to enable the printer 214 to write on disk surfaces. According to one aspect of the invention, the printer 218 is a SIGNATURE® printer and the ink jet cartridge 216 reciprocates across a disk to print on the disk surface as the tray 220 extends.

FIG. 22 shows the printer 214, the recorder 212, the motor 210 and an elevator pin linkage 222. The elevator pin linkage assembly 222 includes a disk dispenser actuator 224 and an elevator pin actuator 226. Accordingly, the elevator pin linkage assembly 222 coordinates the elevator pin 98 and the disk dispenser actuator 224.

The elevator pin 98 extends and retracts. The recorder 212 includes a tray 228. The tray 228 includes a central opening to allow the elevator pin to extend through. A portion of the tray 220 is bifurcated to form a U shaped opening. Bifurcation of at least a portion the tray 220 enables the tray 220 to extend and retract when the elevator pin 98 extends. Accordingly, the tray 220 can extend or retract independently of the relative position of the elevator pin 98.

The tray 220 of the printer 214 and the tray 228 of the recorder 212 oppose each other. This is not the only possible configuration. Conceivably, the recorder trays and printer trays can radially align, or stack above an appropriately configured elevator pin in accordance with the present invention.

FIG. 23 shows the turntable 36 mounted on the frame 208. The recorder 212, the printer 214, and the elevator pin 98 mount adjacent the turntable 36. The recorder tray 220 extends fully. The elevator pin 98 extends through the recorder tray 220, towards the turntable 36. The disk dispenser 38 dispenses a disk 40 onto the elevator pin 98. The elevator pin 98 retracts in the direction of the arrow 230 to lowers the disk 40 onto the recorder tray 220 and continues to retract to free the recorder tray 220 from interference with the elevator pin 98 to enable the recorder tray 220 to retract. After the disk 40 is on the recorder tray 220, and the elevator pin 98 retracts, the recorder tray 220 retracts into the recorder 212 in the direction of the arrow 232 to record data on the disk 40. After data is recorded on the disk 40, the recorder tray 220 extends.

FIG. 24 shows the recorder tray 220 extended after the recorder 212 completes disk recording. The elevator pin 98 extends through the tray 220, lifting the disk 40 from the tray 220, towards the turntable 36 in the direction of the arrow 236. The next step is to print indicia on the disk 40.

FIG. 25 shows the printer tray 228 extending. Because the printer tray 228 is bifurcated, having a U shaped opening, the printer tray 228 moves past the elevator pin 98 to adjacent the disk. The elevator pin 98 lowers the disk 40 onto the printer tray 228 in the direction of the arrow 234.

FIG. 26 shows the printer tray retracting. According to one aspect of the invention, the printer 214 prints on the disk 40 while the printer tray 228 retracts. According to another aspect of the invention, the printer 214 prints on the disk 40 when the printer tray 228 extends. According to either aspect, the printer tray 228 fully re-extends upon completion of printing.

FIG. 27 shows the printer tray 228 extending towards a fully extended position. As the printer tray 228 extends, the

turntable 36 rotates and the elevator pin 98 extends towards the turntable 36 in the direction of the arrow 236.

FIG. 28 shows the turntable 36 rotated to position the accept hopper 48 adjacent the elevator pin 98. The elevator pin 98 lifts the printed disk 40 from the printer tray 228. The elevator pin 98 lifts the printed disk 40 fully onto the turntable 36 into the accept hopper 48.

The turntable 36 rotates to position the disk dispenser 38 above the elevator pin 98, another disk 40 is dispensed, and the elevator pin 98 lowers the newly dispensed disk to the recorder 212 to repeat the sequence shown in FIG. 23–FIG. 28, inclusively.

FIG. 29 shows a disk handling system, generally designated with the reference numeral 300. The disk handling system includes a turntable 36 and multiple disk recorders 212. The system 300 connects to a computer network, or to a stand-alone computer via a standard connection such as a network card and cable, or a serial cable, respectively. Accordingly, data, which is to be duplicated, is communicated to the disk handling system. The multiple disk recorders 212 simultaneously write the data to disks held in the disk recorders 212. When the data is written, the disk handling system 300 sequentially removes the disks from the disk recorders and places the disks on the turntable. This sequence repeats.

It can be appreciated that the disk recorders 212 are but one example of a workstation type, which can be used in accordance with the present invention. For example, the disk recorders 212 may be replaced with disk printers, disk cleaners, disk surface testing devices and other useful devices in accordance with the present invention.

FIG. 30 shows the disk recorders 212, the turntable 36, the mechanical linkage 102 and the elevator pin 98. The disk recorders 212 are stacked in two discrete stacks. The two stacks oppose each other. The elevator pin 98 is interposed between the opposing stacks.

FIG. 31 shows a variation of the invention, wherein the elevator pin 98 defines a central axis 301, the disk recorders 212 stack in a radial array with respect to the central axis 301. The mechanical linkage 102 and elevator pin 98 are interposed centrally between the recorders 212. The elevator pin 98 telescopes to lift disks, at varying heights, from each of the stacked disk recorders 212.

Although the elevator pin 98 aligns with the central axis 301, it can be appreciated that depending on relative position of the disk recorders 212 and the turntable, the elevator pin 98 may be positioned adjacent any of the disk recorders 212. According to another variation, multiple elevator pins 98 may be used. In accordance with the present invention, the elevator pin 98 may be laterally moveable to lift disks from any of the disk recorders 212. Alternatively, the recorders 212 may be moveable, laterally for example, to enable the elevator pin 98 to lift disks from the recorders 212.

FIG. 32 shows the elevator pin 98 in a retracted configuration. The elevator pin 98 includes multiple sleeves. The sleeves include a fixed sleeve 302, an intermediate sleeve 304, a spring member 306, an alignment pin 308, and a working sleeve 310. The intermediate sleeve 304 aligns the working sleeve 310 with the fixed sleeve 302 when the elevator pin 98 telescopes.

The cylindrical sleeves coaxially align and slide with respect to each other to enable the elevator pin 98 to telescope from a retracted configuration to an extended configuration. The spring member 306 contacts least one sleeve and wraps helically around the alignment pin 308 to bias the sleeves apart. The intermediate sleeve 304 slidably retains the alignment pin 308.

The fixed sleeve 302 is affixed to the housing and has an outside diameter, which is relatively smaller than the working sleeve 310 outside diameter. The working sleeve 310 includes fasteners 312. The fasteners 312 attach to the mechanical linkage 102 (FIG. 31) to enable the mechanical linkage 102 to actuate the elevator pin 98.

FIG. 33 shows the elevator pin of FIG. 32 in an extended configuration. The spring member 306 includes a helical spring with two ends. The helical spring is in coaxial alignment within the working sleeve 310. One end pushes against the working sleeve 310. The other end pushes against the intermediate sleeve 304. The spring member 306 functions to sequence movement of the working sleeve 310 relative to the intermediate sleeve 304 during elevator pin 98 extension.

Elevator pin 98 extension is a two-stage process. During the first stage, the working sleeve 310 slides along the intermediate sleeve 304. The spring member 306 biases the intermediate sleeve 304 in a fixed position within the fixed sleeve 302. The second stage begins when the working sleeve 310 extends to reach a maximum extension relative to the intermediate sleeve. The spring member 306 lengthens and allows the intermediate sleeve 304 to slide. The intermediate sleeve 304 slides within the fixed sleeve 302 to enable the working sleeve 310 to extend. Accordingly the working sleeve 310 cooperates with the intermediate sleeve 304 to enable optimal extension of the elevator pin 98 while maintaining precise alignment between the working sleeve 310 and the fixed sleeve 302 during both the initial and later stages of elevator pin 98 extension.

FIG. 34 and FIG. 35 show a variation of the elevator pin 98 in a retracted configuration and in an extended configuration, respectively. The fixed sleeve 302 surrounds the working sleeve 310. The working sleeve 310 includes a cap 314, which overhangs the fixed sleeve 302. During extension, the working sleeve 310 and the intermediate sleeve 304 rotates along a helical path with respect to the fixed sleeve 302. Accordingly, the working sleeve 310 rotates to extend the elevator pin 98.

FIG. 36 shows a variation of the telescoping elevator pin 98. The elevator pin 98 has a coil spring 320 with two ends 322 and 324. The end 322 of the coil spring 320 presses against the working sleeve 310 to slide the working sleeve 310 relative to the intermediate sleeve 304 and thereby actuate the elevator pin 98. Rotation of one end 324 of the coil spring in the direction of the arrow 326 uncoils the spring 320, causing the other end 322 to press against the working sleeve 310 and extend the elevator pin 98. Counter-rotation of the one end 322 of the coil spring 320 causes the other end 324 to retract the elevator pin 98.

FIG. 37 shows the elevator pin 98 fully extended. The second end 322 presses against the working sleeve 310. The spring 320 partially uncoils to support the elevator pin 98 in the fully extended configuration.

FIGS. 38 and 39 shows a linkage assembly 330 and elevator pin 98 combination in a retracted and extended configuration, respectively. The linkage assembly 330 includes a rotatable actuator 332, a threaded sleeve 334 and a pulley mechanism 336. The actuator 332 includes a threaded shaft. The linkage assembly 330 includes linkage members 338. The linkage members 338 has scissor joints. A motor rotates the pulley mechanism 336. The pulley mechanism 336 rotates the actuator 332 with respect to the sleeve 310. The sleeve 310 is joined to at least one linkage member 338 so when the sleeve 310 moves, the linkage assembly 330 scissors to actuate the elevator pin 98. The linkage assembly 330 extends and retracts the elevator pin 98.

FIG. 40 shows a memory storage device handling system generally designated with the reference numeral 400. The system 400 includes a housing 402, an elevator pin 404, a servomotor 406, a linkage assembly 408 and a sensor 410.

The housing 402 defines a base 416 and a hopper generally designated with the reference numeral 418. The hopper 418 functions to hold memory storage disks in a stack, preferably a vertical stack.

The hopper 418 has a stack retainer including posts 420. Three posts 420 define a periphery of the hopper 418. The base 416 is planar and the posts 420 extend perpendicularly with respect to the base 416.

The hopper 418 includes a bottom 422 with an opening 424 for enabling the elevator pin 404 to extend from below the hopper 418, through the bottom of the hopper 418. The hopper 418 has a lateral opening 426 defined on the periphery of the hopper 418 near the bottom 422 of the hopper 418. Disks feed through the lateral opening 426 to rest near the bottom 422 of the hopper 418 on the elevator pin 404. The elevator pin 404 lifts resting disks into the stack retainer portion of the hopper 418, which is the portion of the hopper 418 situated above the lateral opening 426.

Each post 420 includes a pawl slot 430, a pawl pin 432 and a pawl 436. Each pawl 436 includes first end with a hook 438 for holding disks. Each pawl 436 includes a second end inserted into the pawl slot 430. The pawl pin 432 extends through the second end of each pawl 436 to slideably hold each pawl 436 in one of the pawl slots 430.

Each pawl 436 has pin opening 440 for receiving a pawl pin 432 and enabling the pawl 436 to slide between an extended position where the hook 438 extends from the post 420 to a retracted configuration where a portion of the second end of the pawl 436 extends into the pawl slot 430. The pawls 436 hold disks in the extended configuration and, in the retracted configuration the pawls 436 enable the elevator pin 404 to lift disks into a stack from the bottom.

The sensor 410 for detects the position of the elevator pin 404 with respect to the base 416. The sensor 410 includes the mechanical arm 434, which engages a portion of the elevator pin 404 to directly measure the position of the elevator and 404. Although a sensor with the mechanical arm is used in accordance with the present invention a can be appreciated that the position sensor can also include an optical sensor element or a magnetic sensor element.

FIG. 41 shows an embodiment of the present invention where the linkage assembly 408 includes belts and pulleys. The linkage assembly 408 includes a drive pulley 442, a first drive belt 444, an intermediate pulley 446, a second drive belt 448 and an elevator pin pulley 450 operably interconnected to move the elevator pin. Rotation of the elevator pin pulley 450 lifts the elevator pin 404. Alternatively, a mechanism as described with respect to FIG. 38 can be used to lift the elevator pin. There are other ways to lift an elevator pin in response to rotation of a pulley. For example a geared linkage assembly could be substituted in accordance with the present invention for the pulley mechanism, or the cam mechanisms disclosed herein.

FIG. 42 shows for a memory storage device handling system 400 including a conveyor 452. The conveyor 452 delivers disks 40 through the lateral opening 426. Accordingly, the conveyor 423 delivers a memory storage disk 40 to the memory storage device handling system 400 so that the elevator pin 404 can stack the delivered disk 40 in the hopper 418.

FIG. 43A, FIG. 43B, FIG. 43C and FIG. 43D show operation of the elevator pin 404 and the pawls 436. FIG. 43A

shows the elevator pin 404 lifting a single disk 40 into a stack 454 of disks. The elevator pin 404 presses the single disk 40 upwards in the direction of the arrow 456. The single disk 40 engages the stack 454 of disks 40 from the bottom and presses into the stack 454.

FIG. 43B shows that pressing the disk 40 into the stack 454 lifts the stack 454 upwards in the direction of the arrow 458 and adds the single disk 40 to the stack 454 from the bottom of the stack 454. The stack 454 lifts the pawls 436 and causes the pawls 436 to retract into the respective posts 420.

FIG. 43C shows the single disk 40 defining the bottom of the stack 454, which passes the hooked end 438 of each pawl 436. When the bottom of the stack 454 lifts above the hooked end 438 of the pawls 436, the pawls 436 drop downwards into an extended configuration under the influence of gravity, in the direction of the arrows 460.

FIG. 43D shows the elevator pin 404 lowering in the direction of the arrows 462, allowing the stack 454 to rest on the hooked ends 438 of the pawls 436.

Although only a few disks are shown in the stack 454. The present invention is intended to lift a multitude of disks. For example, one hundred or more disks can be lifted by the elevator pin 404 in accordance with the present invention.

FIG. 44A shows an embodiment of the linkage assembly 408. The servomotor 406 includes a shaft 464. The servomotor 406 reciprocates the shaft 464 over an arc of less than 360 degrees. Preferably a servomotor 406 reciprocates the shaft 464 over an arc of less than 90 degrees to rapidly and precisely lift and lower the elevator pin 404.

The linkage assembly 408 includes an arm 466 that mechanically connects the servomotor shaft 464 to the elevator pin 404. The arm 466 has two ends 474 and 476. The end 474 fixedly mounts on the shaft 464 of the servomotor 406. The motor 406 rotates the shaft 464 to pivot the arm 466.

The elevator pin 404 defines an axis 468 that is perpendicular to the base 416 and parallels the force of gravity. The end 474 of the arm 466 cams against the elevator pin 404 to selectively lift and lower the elevator pin 404 along the axis 468.

The elevator pin 404 includes a slot 470 near the base of the elevator pin 404. The slot 470 parallels the base 416 and defines an internal cam surface 472. The end 476 of the arm 466 includes a cam pin 478 that extends through the arm 466 to engage the cam surface 472 of the slot 470. The cam pin 478 slides against the cam surface 472 to selectively lift or lower the elevator pin 404. According to one aspect of the invention, the cam pin 478 includes cylindrical roller that cams against the elevator pin 404.

The arm 466 includes several connection points 480 that enable the cam pin 478 to attach to any of the several connection points 480. The connection points 480 facilitate adjustment of the linkage assembly 408 to achieve precise movement of the elevator pin 404. The cam motor 406 is regulated to precisely rotate the arm 466 over a predetermined angle to lift and lower the elevator pin 404.

It can be appreciated that although the elevator pin 404 includes a cam slot 470, that the present invention does not necessarily require a slot 470 to achieve precise movement of the elevator pin 404.

The cam pin 478 and the elevator pin 404 are adapted, according to an alternate aspect of the invention, to engage a bottom portion of the elevator pin 404. A further alternative include configuring the elevator pin 404 with a protruding

cam surface that extends from the periphery of the elevator pin 404 and engages the cam pin 478 to lift the elevator pin 404.

FIG. 44B shows the servomotor 406 rotating the shaft 464 to pivot the arm 466 and thereby lift the elevator pin 404 along the axis 468 and upwards with respect to the base 416. The cam pin 478 slides with respect to the slot 470 of the elevator pin 404 in the direction of the arrow 482, which parallels the base 416, as the elevator pin 404 lifts. Reciprocation of the servomotor 406 lowers the elevator pin 404.

According to one aspect of the invention at least one guide 484 that attaches to the base 416 to guide the elevator pin 404. The guide 484 prevents rotation of the elevator pin 404 for about the axis 468.

FIG. 45A shows an alternate embodiment of the linkage assembly 408 where the arm 410 defines a slot 486 and the elevator pin 404 includes a cam pin 488. The cam pin 488 extends radially outward from the elevator pin 404 and slidably engages the slot 486 of the arm 466. The slot 486 aligns between the shaft 464 and the cam pin 488 of the elevator pin 404.

FIG. 45B shows the arm 466 pivoting to lift the elevator pin 404 upwards, away from the base 416 in the direction of the arrow 490. The cam pin 488 slides within the slot 486 to enable the arm 466 to lift the elevator pin 404. Although the slot 486 is shown, the slot 486 is not required. The arm 466 can be modified with an alternate cam surface, not including a slot.

FIG. 46A shows a variation of the linkage assembly 408 where the arm 410 has two fixed ends and a rotatable cam pin 494. The end 474 affixes to the shaft 412. The end 476 affixes to the cam pin 494, which inserts into the elevator pin 404.

FIG. 46B shows the arm 466 lifting the elevator pin 404. As the elevator pin 404 lifts away from the base 416 in the direction of the arrow 490. While the elevator pin 404 lifts, the arm 466 rotates the elevator pin 404 in the direction of the arrow 492. Preferably the cam pin 494 includes a ball and socket connection with the arm 466 to prevent the arm 466 and cam pin 494 from binding.

FIG. 47A shows an alternate embodiment of the linkage assembly 408 including a pin cam pin 498, a rocker arm 494, and a cam bud 500. The servomotor 406 rotates the cam bud 500 in the direction of the arrow 502 to actuate the rocker arm 496. Movement of the rocker arm 496 lifts and lowers the elevator pin 404. The servomotor 406 reciprocates to lower the elevator pin 404 in accordance with one aspect of the invention, and the servomotor 406 rotates in a single direction in accordance with an alternate aspect of the invention.

FIG. 47B shows the servo motor 406 reciprocating the cam bud 500 in the direction of the arrow 504 to actuate the rocker arm 496 to lift the elevator pin 404.

While the present invention is described in terms of preferred embodiments, there are many possible variations of the invention that are possible. For example, the linkage can be modified to have an elliptical or other curved cam bud, instead of the cam arm shown in the drawings. Also, placement of the servo motor can change, having an appropriate power train for delivering power to the cam that lifts the elevator pin. Accordingly, the invention is to be limited only by the appended claims.

We claim:

[1. A memory storage disk handling system, comprising: a housing;

an elevator pin mounted on the housing for lifting disks; a servo motor attached to the housing; and

a linkage assembly attached between the servo motor and the elevator pin, wherein the servo motor includes a shaft, the linkage assembly includes an arm mounted on the shaft, whereby rotation of the shaft pivots the arm to lift the elevator pin.]

[2. A memory storage disk handling system as set forth in claim 1, wherein the arm has a fixed end and a moveable end, the fixed end mounts on the shaft, and the moveable end includes a cam surface that cams against the elevator pin when the arm pivots.]

[3. A memory storage disk handling system as set forth in claim 2, wherein the elevator pin has an axis, and a base that lies in a plane perpendicular to the axis, the elevator pin includes a slot that parallels the base, the cam surface cams within the slot to lift the elevator pin in the direction of the axis.]

[4. A memory storage disk handling system as set forth in claim 2, wherein the elevator pin has an axis, a longitudinal surface and a cam pin extending radially outward from the longitudinal surface, the moveable end of the arm defines a slot that cams against the cam pin when the arm pivots.]

[5. A memory storage disk handling system as set forth in claim 1, wherein one end of the arm mounts on the shaft and the other end of the arm mounts on the elevator pin, the elevator pin has an axis, the servo motor pivots the arm to lift the elevator pin in the direction of the axis and the elevator pin rotates about the axis when the arm lifts the elevator pin.]

[6. A memory storage disk handling system as set forth in claim 1, wherein the disks form a stack having a top and a bottom, and wherein a single disk is added to the bottom of the stack.]

[7. A memory storage disk handling system as set forth in claim 1, further comprising a conveyor.]

[8. A memory storage disk handling system as set forth in claim 7, wherein the conveyor delivers disks to the memory storage disk handling system for the elevator pin to stack the delivered disks into a stack.]

[9. A memory storage disk handling system comprising:

a housing defining a hopper for receiving disks;

an elevator pin mounted on the housing for lifting disks into the hopper; and

the hopper being configured for aligning lifted disks into a stack and includes at least one pawl for holding lifted disks in the hopper, wherein the hopper includes a plurality of posts oriented to surround lifted disks, at least one pawl mounts on each post.]

[10. A disk handling system as set forth in claim 9, wherein each of the plurality of posts includes hollow portions and at least two pawls, the pawls being slidably mounted within the hollow portions.]

[11. A disk handling system as set forth in claim 10, wherein each pawl includes a slot and the hopper includes pins that insert through the slots to hold each pawl, the pins and slots cooperate to enable the pawls to slide.]

[12. A disk handling system as set forth in claim 10, wherein each pawl includes an end with a hook for holding lifted disks.]

[13. A memory storage disk handling system comprising:

a housing defining a hopper for receiving disks;

an elevator pin mounted on the housing for lifting disks into the hopper; and

## 15

the hopper being configured for aligning lifted disks into a stack and includes at least one pawl for holding lifted disks in the hopper, wherein the hopper includes three posts oriented to surround lifted disks, at least one pawl mounts on each post.]

[14. A disk handling system as set forth in claim 13, wherein each post includes a hollow portion, the pawls being mounted at least partially within the hollow portions of the posts.]

[15. A disk handling system as set forth in claim 14, wherein the pawls are slidably mounted within the hollow portions of the posts so that lifting a disk slides the pawls into the hollow portions, and after the disk is lifted, the pawls extend from the hollow portions to hold the disk in the hopper.]

[16. A memory storage disk handling system, comprising:  
a housing defining a hopper for holding disks;  
an elevator pin mounted on the housing for lifting disks into the hopper;  
a servo motor attached to the housing;  
a linkage assembly attached between the servo motor and the elevator pin for lifting the elevator pin in response to the servo motor; and

the hopper defines a base and includes a stack retainer means extending from the base for aligning disks in a vertical stack, the stack retainer means includes more than one pawl for holding lifted disks, wherein the hopper includes a plurality of posts oriented to surround lifted disks, at least one pawl mounts on each of the plurality of posts.]

[17. A memory storage disk handling system as set forth in claim 16, wherein the servo motor includes a shaft, the linkage assembly includes a single arm mounted on the shaft.]

[18. A memory storage disk handling system comprising:  
a housing defining a hopper for holding disks;  
an elevator pin mounted on the housing for lifting disks into the hopper;  
a servo motor attached to the housing;  
a linkage assembly attached between the servo motor and the elevator pin for lifting the elevator pin in response to the servo motor, the servo motor includes a shaft, the linkage assembly includes a single arm mounted on the shaft, wherein the arm has a fixed end and a moveable end, the fixed end is fixed with respect to the shaft, the moveable end includes a cam surface that cams against the elevator pin to enable the elevator pin to move in response to the servo motor; and

the hopper defines a base and includes a stack retainer means extending from the base for aligning disks in a vertical stack, the stack retainer means includes more than one pawl for holding lifted disks.]

[19. A disk handling system as set forth in claim 18, wherein the stack retainer means includes three posts oriented to surround lifted disks, each post includes a hollow portion, the pawls normally extend from the post and retract within the hollow portions of the posts when a disk lifts past the pawls.]

[20. A memory storage disk handling system, comprising:  
a housing;  
an elevator pin mounted on the housing, wherein the elevator pin presses a single disk into a stack of disks;  
a servo motor attached to the housing;  
a base having a position sensor; and  
a linkage assembly between the servo motor and the elevator pin wherein the servo motor includes a shaft,

## 16

the linkage assembly includes an arm mounted on the shaft, whereby rotation of the shaft pivots the arm to lift the elevator pin.]

[21. A memory storage disk handling system as set forth in claim 20, wherein the position sensor includes a mechanical arm, the arm engages the elevator pin to detect elevator pin position.]

[22. A memory storage disk handling system as set forth in claim 20, wherein the position sensor includes an optical sensor element.]

[23. A memory storage disk handling system as set forth in claim 20, wherein the position sensor includes a magnetic sensor element.]

[24. A memory storage disk handling system, comprising:  
a housing defining a hopper for holding disks in a stack;  
an elevator pin mounted on the housing for lifting disks into the hopper; and

a plurality of pawls for holding disks, wherein the plurality of pawls slide between a retracted position which enables the elevator pin to lift disks into the stack and an extended position for holding disks, wherein the housing includes a plurality of posts oriented to surround lifted disks, and at least one pawl mounts on each post.]

[25. A disk handling system as set forth in claim 24, further comprising a servo motor and a linkage assembly, wherein the linkage assembly is attached between the servo motor and the elevator pin for lifting the elevator pin in response to the servo motor.]

[26. A disk handling system as set forth in claim 25, wherein the linkage assembly includes at least one belt and at least one pulley.]

[27. A disk handling system as set forth in claim 25, wherein the linkage assembly is a gear linkage assembly.]

[28. The disk handling system as set forth in claim 24, wherein the disks are retained in a vertical stack.]

29. A dispenser comprising:

a first member configured to support a bottom disk of a vertical stack of disks, the first member including a horizontal surface that is configured to receive an outer edge of the bottom disk so that a bottom surface of only the outer edge rests on the horizontal surface;

a second member operable in response to actuation to push the outer edge of the bottom disk off the horizontal surface, the second member having a thickness that is equal to or less than a thickness of the bottom disk so that only the bottom disk is pushed; and

a third member configured to prevent an outer edge of a next-to--bottom disk of the vertical stack of disks from being pushed off the horizontal surface when the second member pushes the bottom disk, the third member having a side surface configured to act as a stop,

wherein actuation of the second member pushes only the bottom disk off the horizontal surface causing only the bottom disk to fall out of the dispenser.

30. The dispenser of claim 29, wherein:

the disk is a compact disc or a digital versatile disc.

31. The dispenser of claim 29, wherein:

the third member is an upper guide that is situated on top of the first member and that includes an aperture configured to guide the bottom disk to a resting position at which the bottom surface of only the outer edge of the bottom disk rests on the horizontal surface of the first member.

32. The dispenser of claim 31, wherein:

the side surface configured to act as a stop is a side surface of the aperture in the upper guide.

17

33. The dispenser of claim 31, wherein:  
the first member is a lower guide that includes an aperture sized and shaped to allow the bottom disk to fall through; and  
the horizontal surface on which the outer edge of the bottom disk rests is located at an edge of the aperture in the lower guide.
34. The dispenser of claim 33, wherein:  
the aperture of the lower guide has a first central axis;  
the aperture of the upper guide has a second central axis;  
and  
the first and second axes are offset relative to each other.
35. The dispenser of claim 33, wherein:  
the second member is a plate that includes an aperture configured to circumscribe and receive the bottom disk, the plate being situated between the upper and lower guides; and  
the plate is operable to slide from a first position to a second position, the first position situating the bottom disk at the resting position and the second position situating the bottom disk off the horizontal surface, whereby movement of the plate from the first position to the second position pushes the outer edge of the bottom disk off the horizontal surface.
36. The dispenser of claim 35, wherein:  
the outer edge of the bottom disk is a first outer edge, the bottom disk including a second outer edge opposite the first outer edge;  
the horizontal surface of the lower guide is a first horizontal surface, the lower guide including a second horizontal surface at an edge of the aperture in the lower guide, the second horizontal surface being on an opposite side of the lower guide's aperture as the first horizontal surface; and  
movement of the plate from the first position to the second position causes the first outer edge of the bottom disk to fall off the first horizontal surface and a subsequent movement of the plate from the second position to the first position causes the second outer edge of the bottom disk to fall off the second horizontal surface, whereby the bottom disk is dispensed to fall through the aperture in the lower guide.
37. The dispenser of claim 36, wherein:  
the subsequent movement of the plate from the second position to the first position also positions the next-to-bottom disk in the resting position.
38. The dispenser of claim 36, wherein:  
the plate is spring loaded to return from the second position to the first position.
39. The dispenser of claim 36, further comprising:  
a fourth member having a side surface against which disks above the vertical stack of disks can rest.
40. The dispenser of claim 36, wherein:  
the lower guide is situated to dispense the bottom disk to an extended tray of a digital data reader, a digital data writer, or a printer.
41. The dispenser of claim 29, wherein:  
the bottom disk is dispensed without being deformed.
42. A method for dispensing a disk, the method comprising:  
providing a lower member with an aperture configured to pass a first disk of a particular type, the lower member having a horizontal surface by an edge of the aperture that is configured to receive an outer edge of the first

18

- disk so that a bottom surface of only the outer edge rests on the horizontal surface, preventing the first disk from falling through the aperture of the lower member;  
using an upper guide that includes an aperture through which the first disk and a second disk of the particular type can pass to stack the disks in a vertical stack such that the edge portion of the first disk rests on the horizontal surface and the second disk rests on the first disk; and  
in response to actuation, causing a pusher to push, at the outer edge, the first disk off the horizontal surface and into the aperture of the lower member, the pusher having a thickness that is equal to or less than a thickness of the first disk so that only the first disk is pushed, the aperture in the upper guide preventing the second disk from being pushed into the aperture in the lower member when the first disk is being pushed, wherein the first disk but not the second disk is dispensed to fall through the aperture in the lower member when the pusher is actuated.
43. The method of claim 42, wherein:  
the outer edge of the first disk is a first outer edge, the first disk including a second outer edge that is opposite the first outer edge;  
the horizontal surface of the lower member is a first horizontal surface and the edge of the aperture in the lower member is a first edge of the aperture, the lower member having a second horizontal surface by a second edge of the aperture that is opposite the first edge of the aperture; and  
the pusher pushes in a reciprocating action that includes a first movement and a second reciprocating movement so that the first movement pushes the first outer edge of the first disk off the first horizontal surface and the second movement pushes the second outer edge of the first disk off the second horizontal surface.
44. A method for dispensing a disk, the method comprising:  
stacking two or more disks of a particular type in a vertical stack and on a horizontal surface where the horizontal surface is configured to receive an outer edge of a bottom disk so that a bottom surface of only the outer edge rests on the horizontal surface, preventing the bottom disk from falling through an aperture; and  
pushing only the bottom disk off the horizontal surface, the pushing being effected at an outer edge of the bottom disk and while disks on top of the bottom disk are held so that they are not pushed off the horizontal surface, wherein the pushing dispenses only the bottom disk from the stack.
45. The method of claim 44, wherein:  
the bottom disk includes an edge portion; and  
stacking is effected such that only the bottom surface of the edge portion rests on the horizontal surface.
46. The method of claim 45, wherein:  
the edge portion has a horizontal extent; and  
pushing is effected so that the bottom disk is displaced by a distance less than or equal to the horizontal extent.
47. The method of claim 46, wherein:  
the horizontal surface is adjacent to an aperture configured to allow the bottom disk to fall through; and  
the pushing causes the disk to fall through the aperture.
48. The method of claim 47, wherein:  
stacking includes using a guide to position the two or more disks.



49. The method of claim 48, further comprising:  
when the bottom disk is dispensed, guiding the bottom disk to fall into an extended tray of a data writer, a data reader, or a printer.

50. A dispenser comprising:  
a first member configured to support a bottom disk of a vertical stack of disks, the first member including a horizontal surface that is configured to receive an outer edge of the bottom disk so that a bottom surface of only the outer edge rests on the horizontal surface;  
a second member operable in response to actuation to push the outer edge of the bottom disk off the horizontal surface so that only the bottom disk is pushed; and  
wherein actuation of the second member pushes only the bottom disk off the horizontal surface causing only the bottom disk to drop.

51. The dispenser of claim 50, further comprising:  
a third member configured to hold one or more next-to-bottom disks of the vertical stack of disks while the second member pushes the bottom disk, the third member having a side surface configured to act as a stop.

52. The dispenser of claim 51, wherein:  
the third member is an upper guide that is situated on top of the first member and that includes an aperture configured to guide the bottom disk to a resting position at which the bottom surface of only the outer edge of the bottom disk rests on the horizontal surface of the first member.

53. The dispenser of claim 52, wherein:  
the first member includes an aperture configured to allow the bottom disk to fall through; and  
the horizontal surface on which the outer edge of the bottom disk rests is located at an edge of the aperture in the first member.

54. The dispenser of claim 53, where the horizontal surface is adapted to interact with the second member such that only the bottom disk from the vertical stack is pushed.

55. The dispenser of claim 53, wherein:  
the second member is a plate that includes an aperture configured to receive the bottom disk, the plate being positioned between the upper and lower guides; and  
the plate is operable to slide from a first position to a second position, the first position situating the bottom disk at the resting position and the second position situating the bottom disk off the horizontal surface, whereby movement of the plate from the first position to the second position pushes the outer edge of the bottom disk off the horizontal surface.

56. The dispenser of claim 55, where the aperture of the second member is adapted to pass disks from the vertical stack one at a time.

57. The dispenser of claim 55, wherein:  
the outer edge of the bottom disk is a first outer edge, the bottom disk including a second outer edge opposite the first outer edge;  
the horizontal surface of the lower guide is a first horizontal surface, the lower guide including a second horizontal surface at an edge of the aperture in the lower guide, the second horizontal surface being on an opposite side of the lower guide's aperture as the first horizontal surface; and  
movement of the plate from the first position to the second position causes the first outer edge of the bottom disk to fall off the first horizontal surface and the second outer edge of the bottom disk to rest on the second horizontal

surface and where a subsequent movement of the plate from the second position to the first position causes the second outer edge of the bottom disk to fall off the second horizontal surface, whereby the bottom disk is dispensed to fall through the aperture in the lower guide.

58. The method of claim 57, where in the first position, the first outer edge rests on the first horizontal surface and the second outer edge rests on a third horizontal surface, the third horizontal surface being a surface of the plate.

59. A memory storage disk handling system, comprising:  
a housing;  
an elevator pin mounted on the housing for lifting disks;  
a servo motor attached to the housing; and a linkage assembly attached between the servo motor and the elevator pin, wherein the servo motor includes a shaft, the linkage assembly includes an arm mounted on the shaft, whereby rotation of the shaft pivots the arm to lift the elevator pin.

60. A memory storage disk handling system as set forth in claim 59, wherein the arm has a fixed end and a moveable end, the first end mounts on the shaft, and the moveable end includes a cam surface that cams against the elevator pin when the arm pivots.

61. A memory storage disk handling system as set forth in claim 60, wherein the elevator pin has an axis, and a base that lies in a plane perpendicular to the axis, the elevator pin includes a slot that parallels the base, the cam surface cams within the slot to lift the elevator pin in the direction of the axis.

62. A memory storage disk handling system as set forth in claim 60, wherein the elevator pin has an axis, a longitudinal surface and a cam pin extending radially outward from the longitudinal surface, the moveable end of the arm defines a slot that cams against the cam pin when the arm pivots.

63. A memory storage disk handling system as set forth in claim 59, wherein one end of the arm mounts on the shaft and the other end of the arm mounts on the elevator pin, the elevator pin has an axis, the servo motor pivots the arm to lift the elevator pin in the direction of the axis and the elevator pin rotates about the axis when the arm lifts the elevator pin.

64. A memory storage disk handling system as set forth in claim 59, wherein the disks form a stack having a top and a bottom, and wherein a single disk is added to the bottom of the stack.

65. A memory storage disk handling system as set forth in claim 59, further comprising a conveyor.

66. A memory storage disk handling system as set forth in claim 65, wherein the conveyor delivers disk to the memory storage disk handling system for the elevator pin to stack the delivered disks into a stack.

67. A memory storage disk handling system comprising:  
a housing defining a hopper for received disks;  
an elevator pin mounted on the housing for lifting disks into the hopper; and  
the hopper being configured for aligning lifted disks into a stack and includes at least one pawl for holding lifted disks in the hopper, wherein the hopper includes a plurality of posts oriented to surround lifted disks, at least one pawl mounts on each post.

68. A disk handling system as set forth in claim 67, wherein each of the plurality of posts includes hollow portions and at least two pawls, the pawls being slidably mounted within the hollow portions.

69. A disk handling system as set forth in claim 68, wherein each pawl includes a slot and the hopper includes

21

*pins that insert through the slots to hold each pawl, the pins and slots cooperate to enable the pawls to slide.*

70. *A disk handling system as set forth in claim 68, wherein each pawl includes an end with a hook for holding lifted disks.*

71. *A memory storage disk handling system comprising: a housing defining a hopper for receiving disks; an elevator pin mounted on the housing for lifting disks into the hopper; and the hopper being configured for aligning lifted disks into a stack and includes at least one pawl for holding lifted disks in the hopper, wherein the hopper includes three posts oriented to surround lifted disks, at least one pawl mounts on each post.*

72. *A disk handling system as set forth in claim 71, wherein each post includes a hollow portion, the pawls being mounted at least partially within the hollow portions of the posts.*

73. *A disk handling system as set forth in claim 72, wherein the pawls are slidably mounted within the hollow portions of the posts so that lifting a disk slides the pawls into the hollow portions, and after the disk is lifted, the pawls extend from the hollow portions to hold the disk in the hopper.*

74. *A memory storage disk handling system, comprising: a housing defining a hopper for holding disks; an elevator pin mounted on the housing for lifting disks into the hopper; a servo motor attached to the housing; a linkage assembly attached between the servo motor and the elevator pin for lifting the elevator pin in response to the servo motor; and the hopper defines a base and includes a stack retainer means extending from the base for aligning disks in a vertical stack, the stack retainer means includes more than one pawl for holding lifted disks, wherein the hopper includes a plurality of posts oriented to surround lifted disks, at least one pawl mounts on each of the plurality of posts.*

75. *A memory storage disk handling system as set forth in claim 74, wherein the servo motor includes a shaft, the linkage assembly includes a single arm mounted on the shaft.*

76. *A memory storage disk handling system comprising: a housing defining a hopper for holding disks; an elevator pin mounted on the housing for lifting disks into the hopper; a servo motor attached to the housing; a linkage assembly attached between the servo motor and the elevator pin for lifting the elevator pin in response to the servo motor, the servo motor includes a shaft, the linkage assembly includes a single arm mounted on the shaft, wherein the arm has a fixed end and a moveable end, the fixed end is fixed with respect to the shaft, the moveable end includes a cam surface that cams against the elevator pin to enable the elevator pin to move in response to the servo motor; and*

22

*the hopper defines a base and includes a stack retainer means extending from the base for aligning disks in a vertical stack, the stack retainer means includes more than one pawl for holding lifted disks.*

77. *A disk handling system as set forth in claim 76, wherein the stack retainer means includes three posts oriented to surround lifted disks, each post includes a hollow portion, the pawls normally extend from the post and retract within the hollow portions of the posts when a disk lifts past the pawls.*

78. *A memory storage disk handling system, comprising: a housing; an elevator pin mounted on the housing, wherein the elevator pin presses a single disk into a stack of disks; a servo motor attached to the housing; a base having a position sensor; and a linkage assembly between the servo motor and the elevator pin wherein the servo motor includes a shaft, the linkage assembly includes an arm mounted on the shaft, whereby rotation of the shaft pivots the arm to lift the elevator pin.*

79. *A memory storage disk handling system as set forth in claim 78, wherein the position sensor includes a mechanical arm, the arm engages the elevator pin to detect elevator pin position.*

80. *A memory storage disk handling system as set forth in claim 78, wherein the position sensor includes an optical sensor element.*

81. *A memory storage disk handling system as set forth in claim 78, wherein the position sensor includes a magnetic sensor element.*

82. *A memory storage disk handling system, comprising: a housing defining a hopper for holding disks in a stack; an elevator pin mounted on the housing for lifting disks into the hopper; and a plurality of pawls for holding disks, wherein the plurality of pawls slide between a retracted position which enables the elevator pin to lift disks into the stack and an extended position for holding disks, wherein the housing includes a plurality of posts oriented to surround lifted disks, and at least one pawl mounts on each post.*

83. *A disk handling system as set forth in claim 82, further comprising a servo motor and a linkage assembly, wherein the linkage assembly is attached between the servo motor and the elevator pin for lifting the elevator pin in response to the servo motor.*

84. *A disk handling system as set forth in claim 83, wherein the linkage assembly includes at least one belt and at least one pulley.*

85. *A disk handling system as set forth in claim 83, wherein the linkage assembly is a gear linkage assembly.*

86. *A disk handling system as set forth in claim 82, wherein the disks are retained in a vertical stack.*

\* \* \* \* \*

UNITED STATES PATENT AND TRADEMARK OFFICE  
**CERTIFICATE OF CORRECTION**

PATENT NO. : RE 40,598 E  
APPLICATION NO. : 11/322203  
DATED : December 2, 2008  
INVENTOR(S) : Wray Russ

Page 1 of 1

It is certified that error appears in the above-identified patent and that said Letters Patent is hereby corrected as shown below:

Title page, Other Publications in the List of References, at Column 2, Line 9; replace:  
“5, 2005] retrieved from the Internet <URL:http://facstaff.” with  
--5, 2005] retrieved from the Internet <URL:http://facstaff.--

Column 16, approximately Line 49 at Claim 29; replace:  
“next-to--bottom disk of the vertical stack of disks from” with  
--next-to-bottom disk of the vertical stack of disks from--

Column 20, approximately Line 21 at Claim 60; replace:  
“end, the first end mounts on the shaft, and the moveable end” with  
--end, the fixed end mounts on the shaft, and the moveable end--

Column 20, approximately Line 49 at Claim 66; replace:  
“claim 65, wherein the conveyor delivers disk to the memory” with  
--claim 65, wherein the conveyor delivers disks to the memory--

Column 20, Line 54 at Claim 67; replace:  
“a housing defining a hopper for received disks;” with  
--a housing defining a hopper for receiving disks;--

Column 21, Line 39 at Claim 74; replace:  
“lifted disks, at least one pawl mounts one each of the” with  
--lifted disks, at least one pawl mounts on each of the--

Signed and Sealed this

Twenty-fourth Day of November, 2009

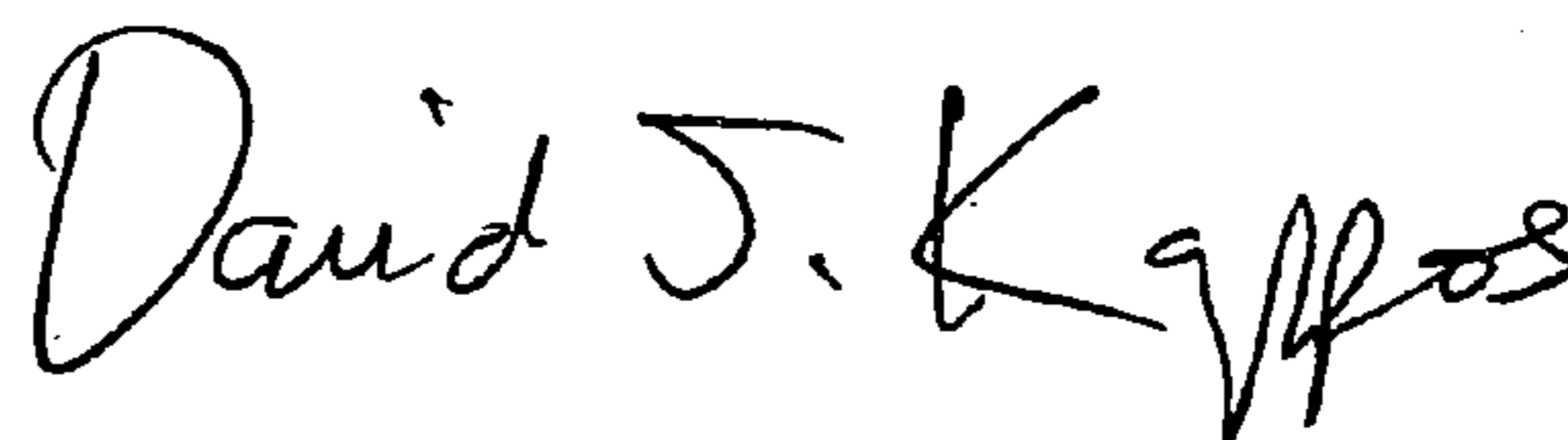

David J. Kappos  
*Director of the United States Patent and Trademark Office*