

US00RE40347E

(19) **United States**
(12) **Reissued Patent**
Fujii

(10) **Patent Number:** **US RE40,347 E**
(45) **Date of Reissued Patent:** **Jun. 3, 2008**

(54) **ACCELERATION SENSOR AND PROCESS FOR THE PRODUCTION THEREOF**

FOREIGN PATENT DOCUMENTS

(75) Inventor: **Tetsuo Fujii**, Toyohashi (JP)
(73) Assignee: **DENSO Corporation**, Kariya (JP)
(21) Appl. No.: **10/123,220**
(22) Filed: **Apr. 17, 2002**

GB	2 240 178	7/1991
GB	2 246 635	2/1992
JP	59-44875	3/1984
JP	60-29629	2/1985
JP	61-73071	* 12/1985
JP	60-244864	12/1985
JP	62-27666	* 2/1987

(Continued)

Related U.S. Patent Documents

Reissue of:

(64) Patent No.: **6,227,049**
Issued: **May 8, 2001**
Appl. No.: **08/566,600**
Filed: **Dec. 4, 1995**

U.S. Applications:

(63) Continuation of application No. 08/167,976, filed on May 11, 1994, now abandoned.

(30) **Foreign Application Priority Data**

Apr. 27, 1992 (JP) 4-108020
Apr. 23, 1993 (WO) PCT/JP93/00535

(51) **Int. Cl.**
G01P 15/125 (2006.01)

(52) **U.S. Cl.** **73/514.18; 73/514.32;**
73/514.36

(58) **Field of Classification Search** **73/514.16,**
73/514.32, 514.18, 514.36
See application file for complete search history.

(56) **References Cited**

U.S. PATENT DOCUMENTS

4,483,194 A	11/1984	Rudolf
4,507,705 A	3/1985	Hoshino et al.
4,574,327 A	3/1986	Wilner
4,598,585 A	7/1986	Boxenhorn
4,653,326 A	3/1987	Danel et al.

(Continued)

OTHER PUBLICATIONS

Office Action issued by Japanese Patent Office on Oct. 23, 2001 in connection with Priority Application No. JP-4-108020 and citing various ones of above references. Payne et al., "Surface Micromachined Accelerometer: A Technology Update," *SAE Technical Paper Series*, Feb. 25, 1991, pp. 127-135.

Primary Examiner—Helen Kwok

(74) *Attorney, Agent, or Firm*—Harness, Dickey & Pierce, PLC

(57) **ABSTRACT**

A single crystal silicon substrate (1) is bonded through an SiO₂ film (9) to a single crystal silicon substrate (8), and the single crystal silicon substrate (1) is made into a thin film. A cantilever (13) is formed on the single crystal silicon substrate (1), and the thickness of the cantilever (13) in a direction parallel to the surface of the single crystal silicon substrate (1) is made smaller than the thickness of the cantilever in the direction of the depth of the single crystal silicon substrate (1), and movable in a direction parallel to the substrate surface. In addition, the surface of the cantilever (13) and the part of the single crystal silicon substrate (1), opposing the cantilever (13), are respectively, coated with an SiO₂ film (5), so that an electrode short circuit is prevented in a capacity-type sensor. In addition, a signal-processing circuit (10) is formed on the single crystal silicon substrate (1), so that signal processing is performed as the cantilever (13) moves.

33 Claims, 15 Drawing Sheets

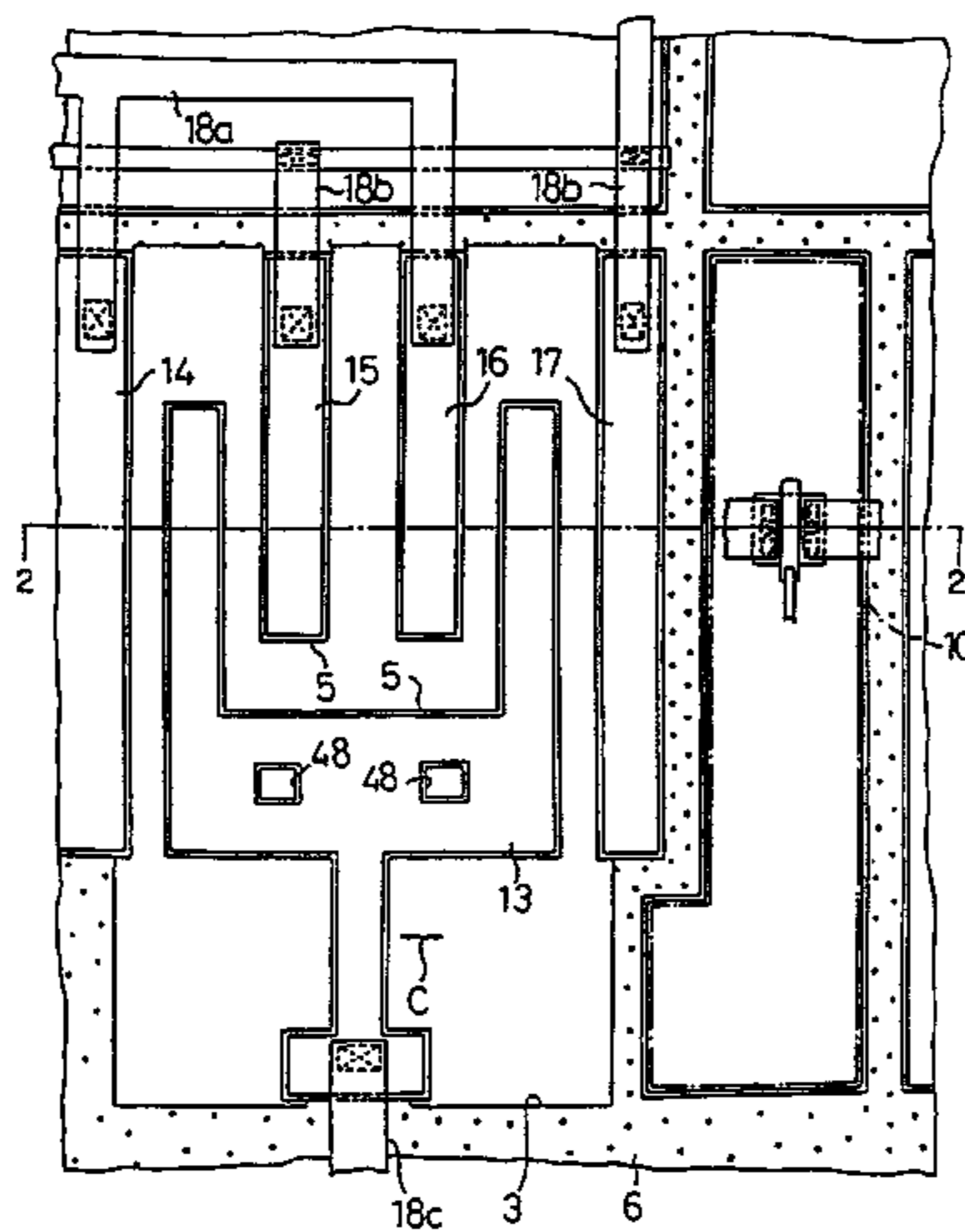

US RE40,347 E

Page 2

U.S. PATENT DOCUMENTS

4,679,434 A 7/1987 Stewart
4,711,128 A 12/1987 Boura
4,783,237 A 11/1988 Aine et al.
4,891,984 A 1/1990 Fujii et al.
4,896,268 A 1/1990 MacGugan
4,951,510 A 8/1990 Holm-Kennedy et al.
5,006,487 A 4/1991 Stokes
5,008,774 A 4/1991 Bullis et al.
5,095,349 A 3/1992 Fujii et al.
5,115,291 A 5/1992 Stokes
5,151,763 A 9/1992 Marek et al.
5,233,213 A 8/1993 Marek
5,243,861 A 9/1993 Kloeck et al.
5,284,057 A 2/1994 Staller et al.
5,296,730 A 3/1994 Takano et al.
5,313,836 A 5/1994 Fujii et al.
5,314,572 A 5/1994 Core et al.
5,331,853 A 7/1994 Hulsing, II
5,337,606 A 8/1994 Bennett et al.
5,345,824 A 9/1994 Sherman et al.
5,359,893 A 11/1994 Dunn
5,417,111 A 5/1995 Sherman et al.
5,495,761 A 3/1996 Diem et al.
5,511,420 A 4/1996 Zhao et al.

5,542,295 A 8/1996 Howe et al.
5,561,248 A 10/1996 Negoro
5,563,343 A 10/1996 Shaw et al.
5,610,335 A 3/1997 Shaw et al.

FOREIGN PATENT DOCUMENTS

JP 62-93668 4/1987
JP 62-174978 7/1987
JP 62-207917 9/1987
JP 62-232171 10/1987
JP 63-25982 2/1988
JP 63-250865 10/1988
JP 2-237166 9/1990
JP 2-309259 12/1990
JP 3-94168 4/1991
JP 91/12497 8/1991
JP 3-205565 9/1991
JP 4-76956 3/1992
JP 40404076956 A * 3/1992
JP 6-88837 3/1994
JP 6-173071 6/1994
JP 6-227666 8/1994
JP 8-510837 11/1996

* cited by examiner

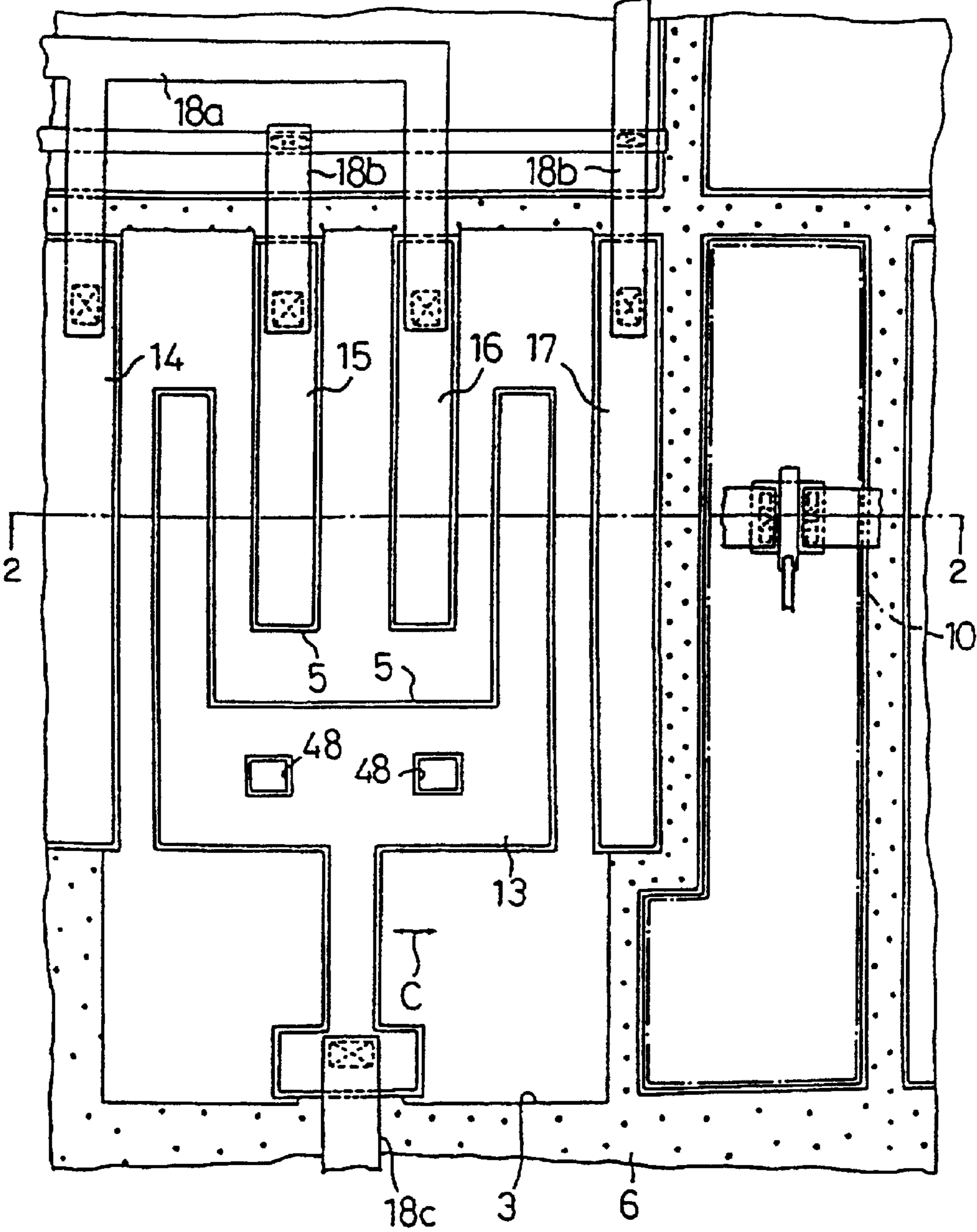

FIG. 1

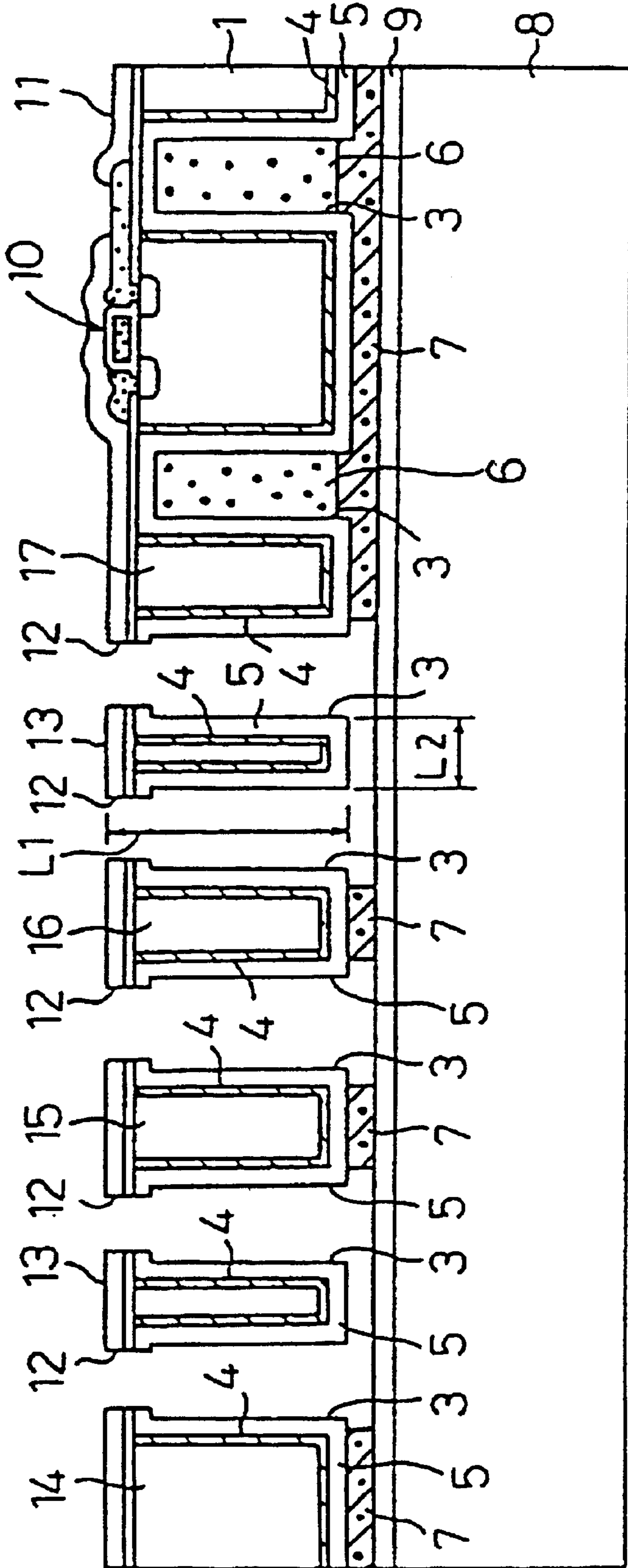

FIG. 2

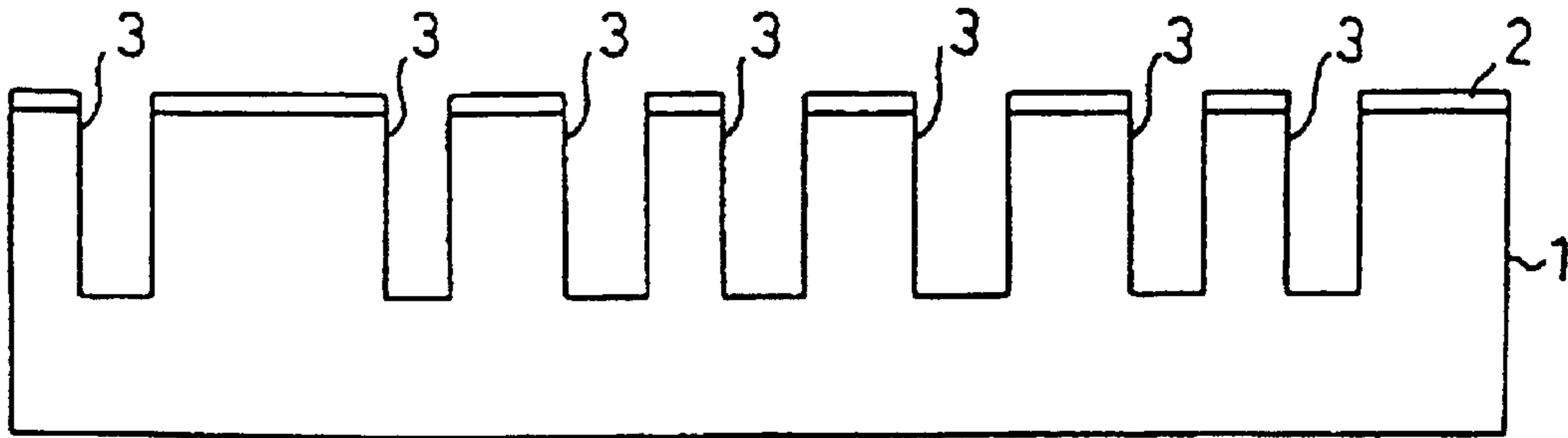

FIG. 3

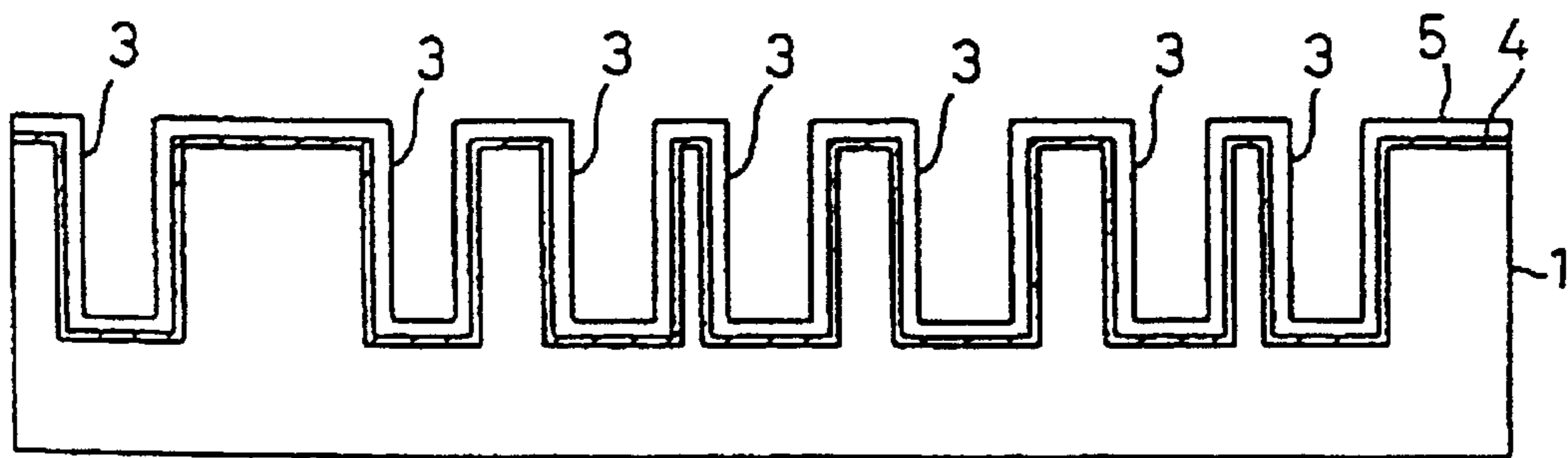

FIG. 4

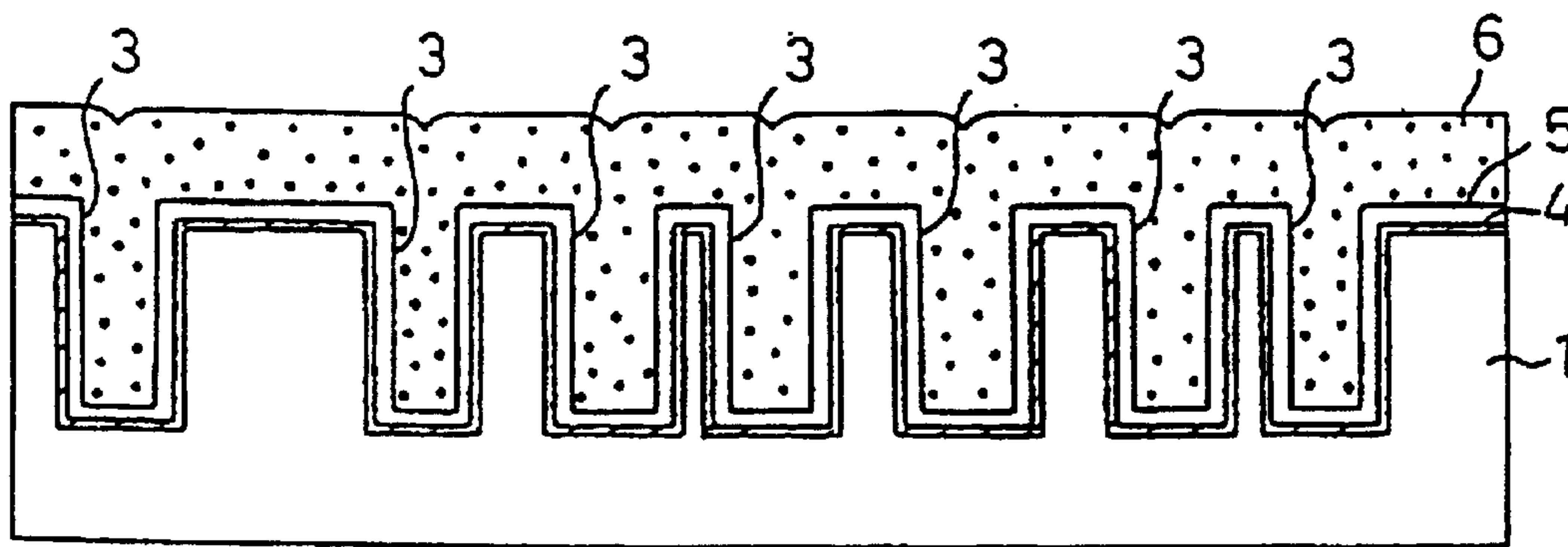

FIG. 5

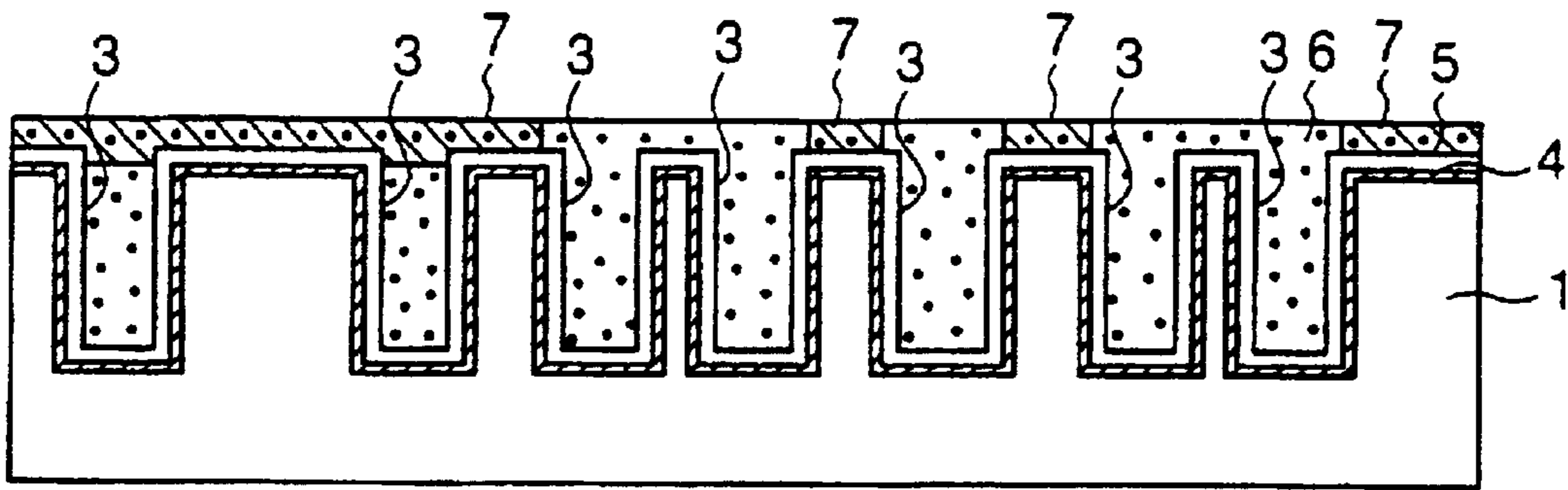

FIG. 6

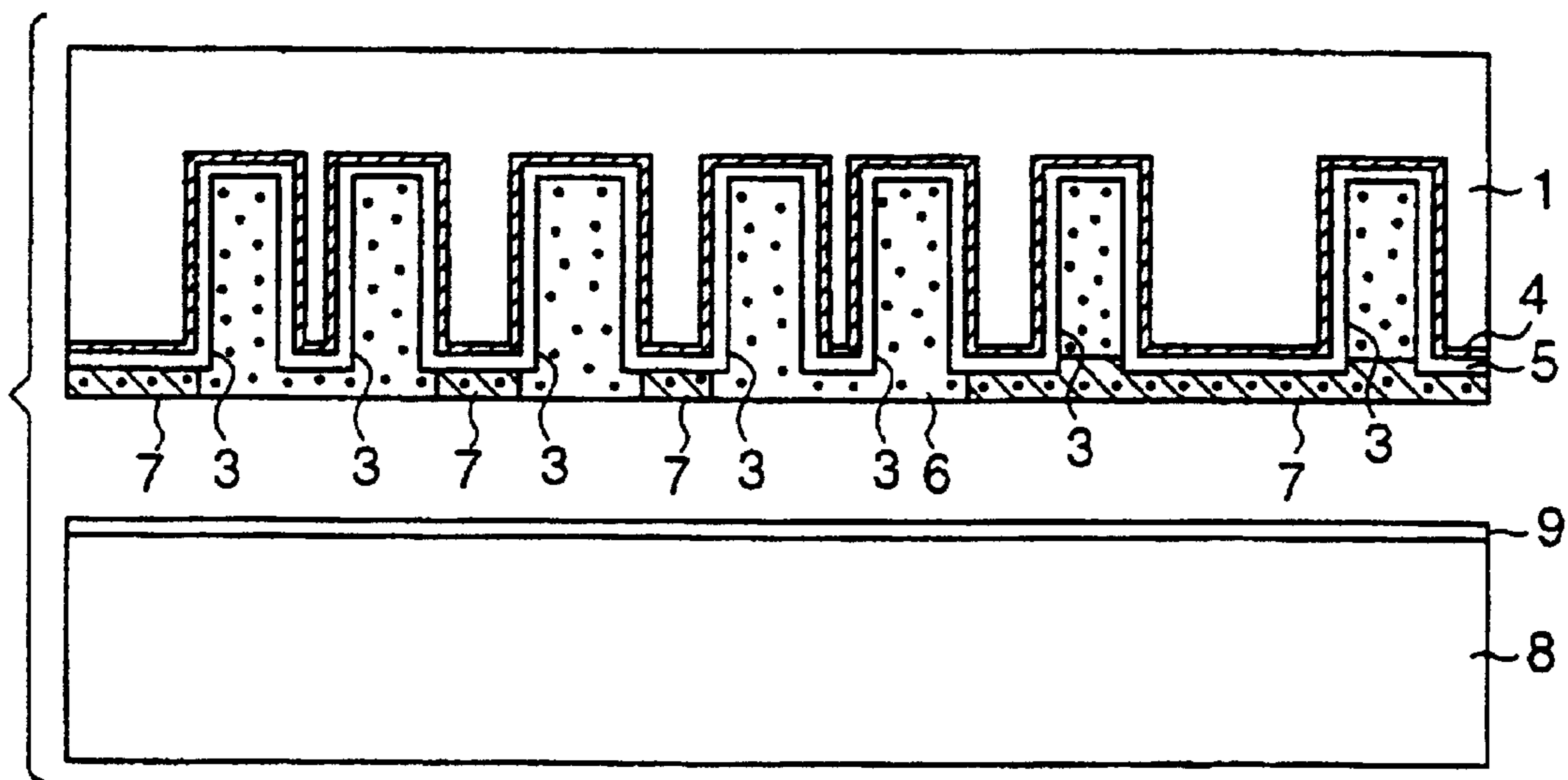

FIG. 7

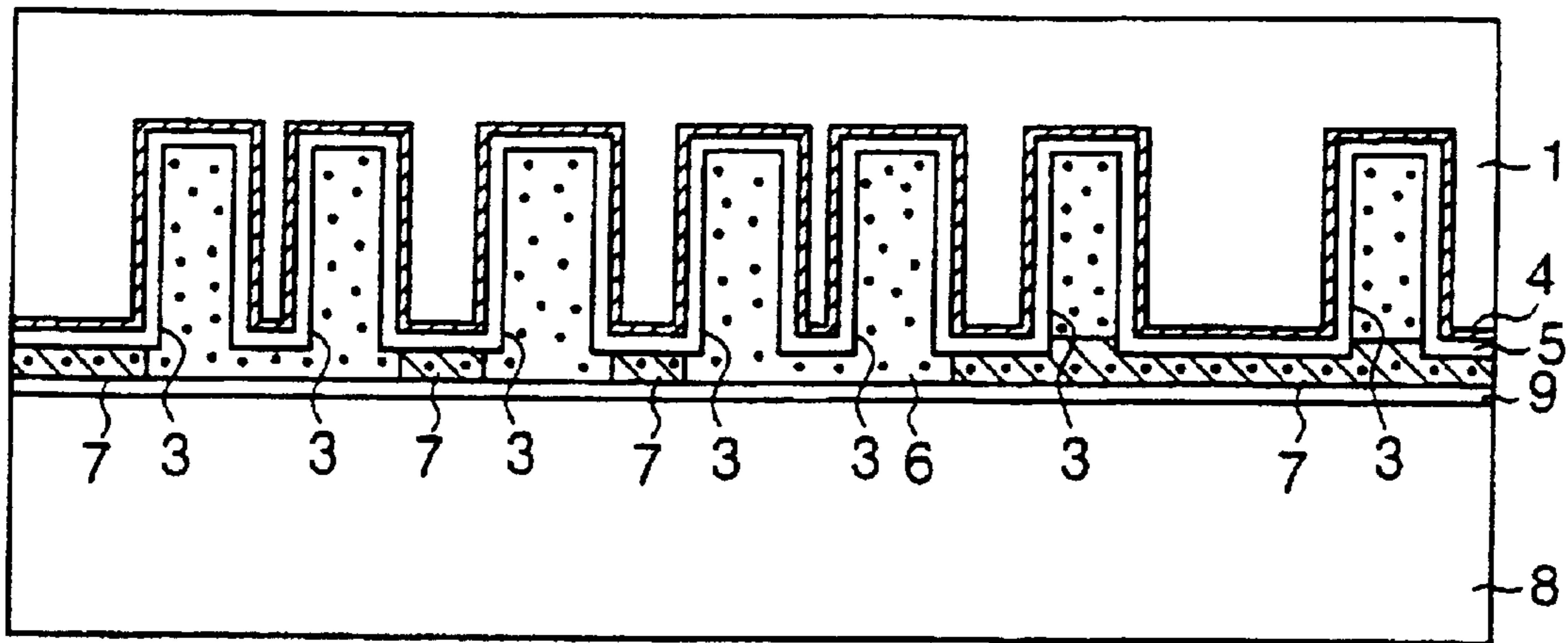

FIG. 8

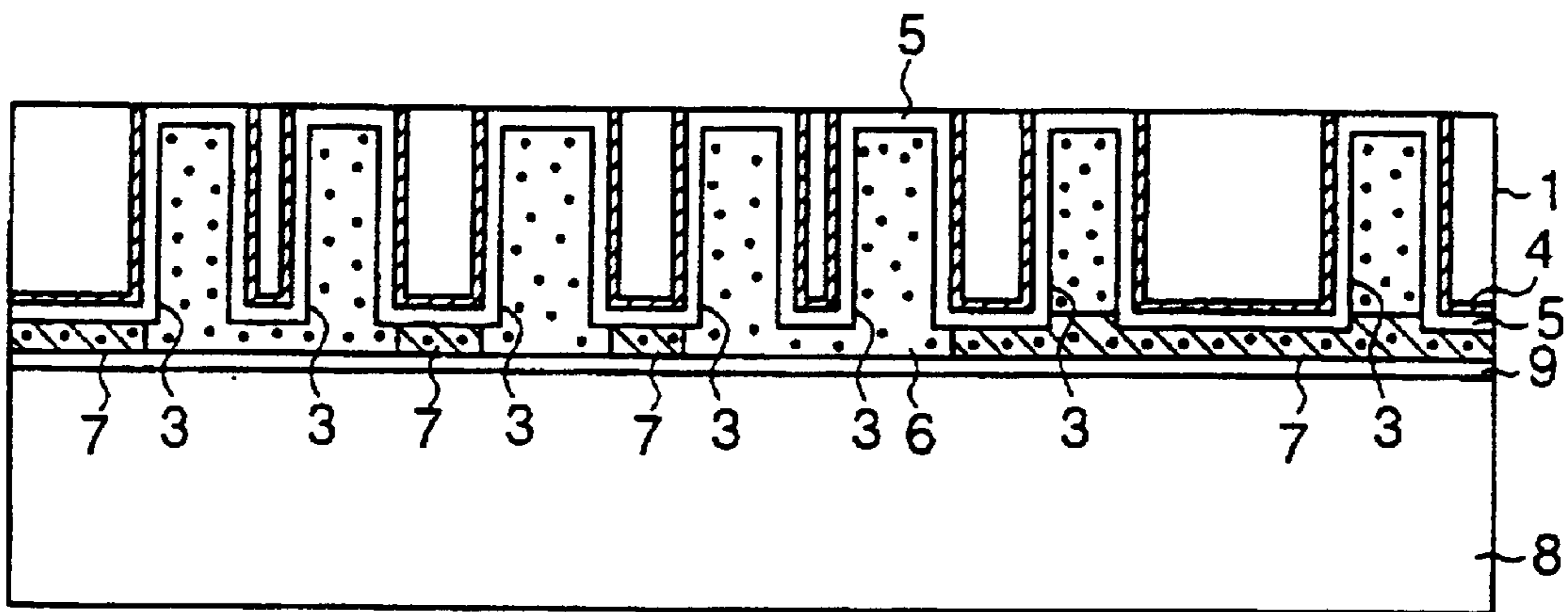

FIG. 9

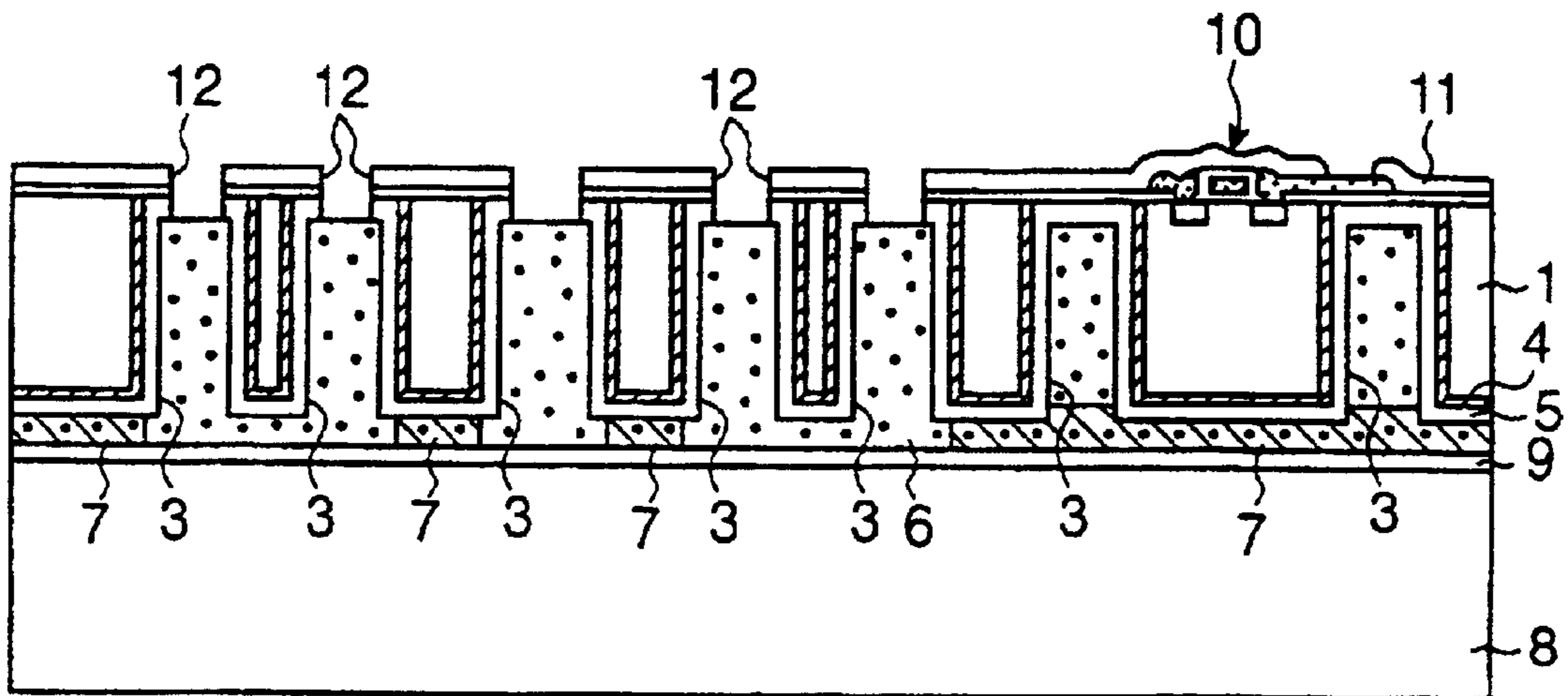

FIG. 10

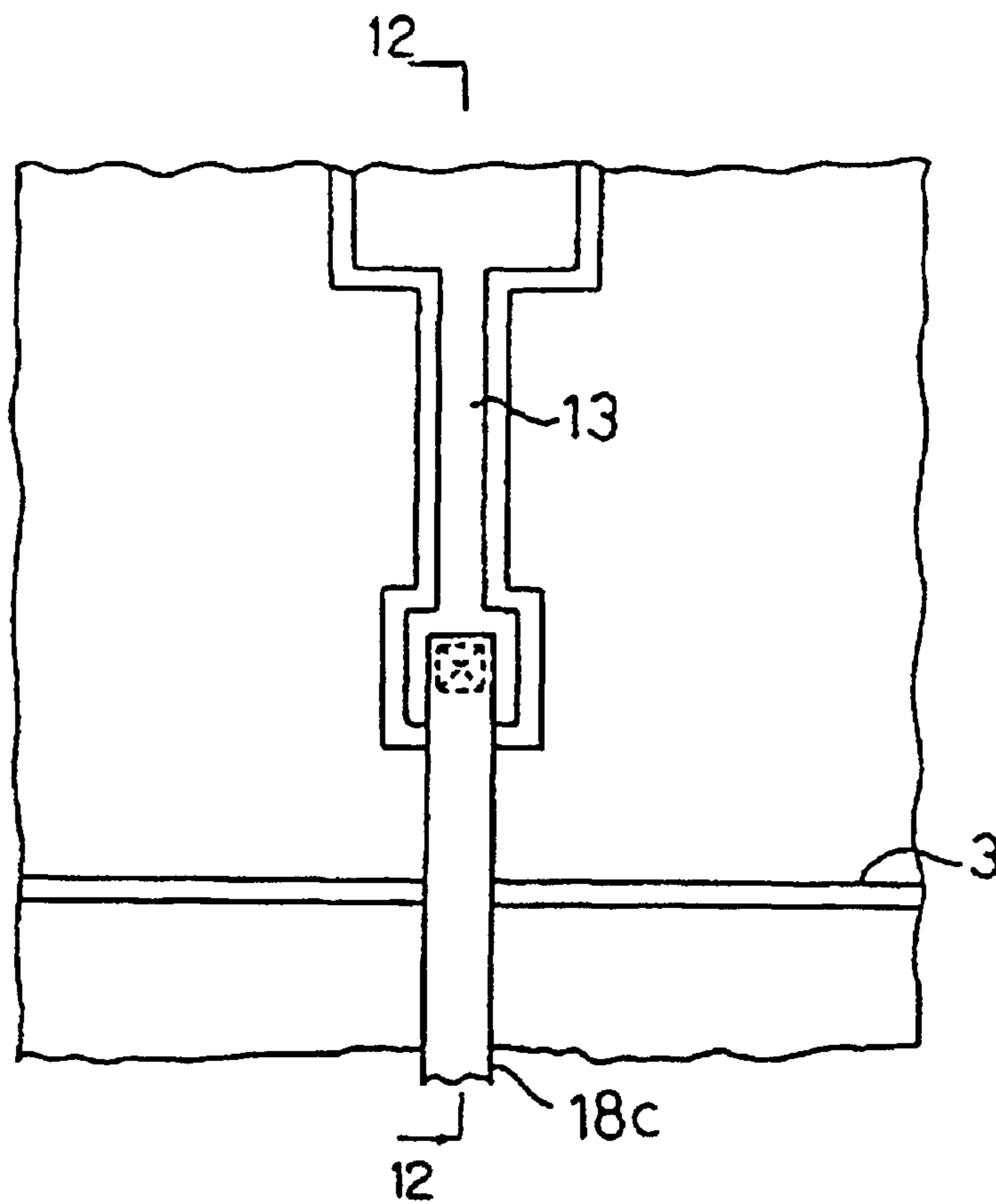

FIG. 11

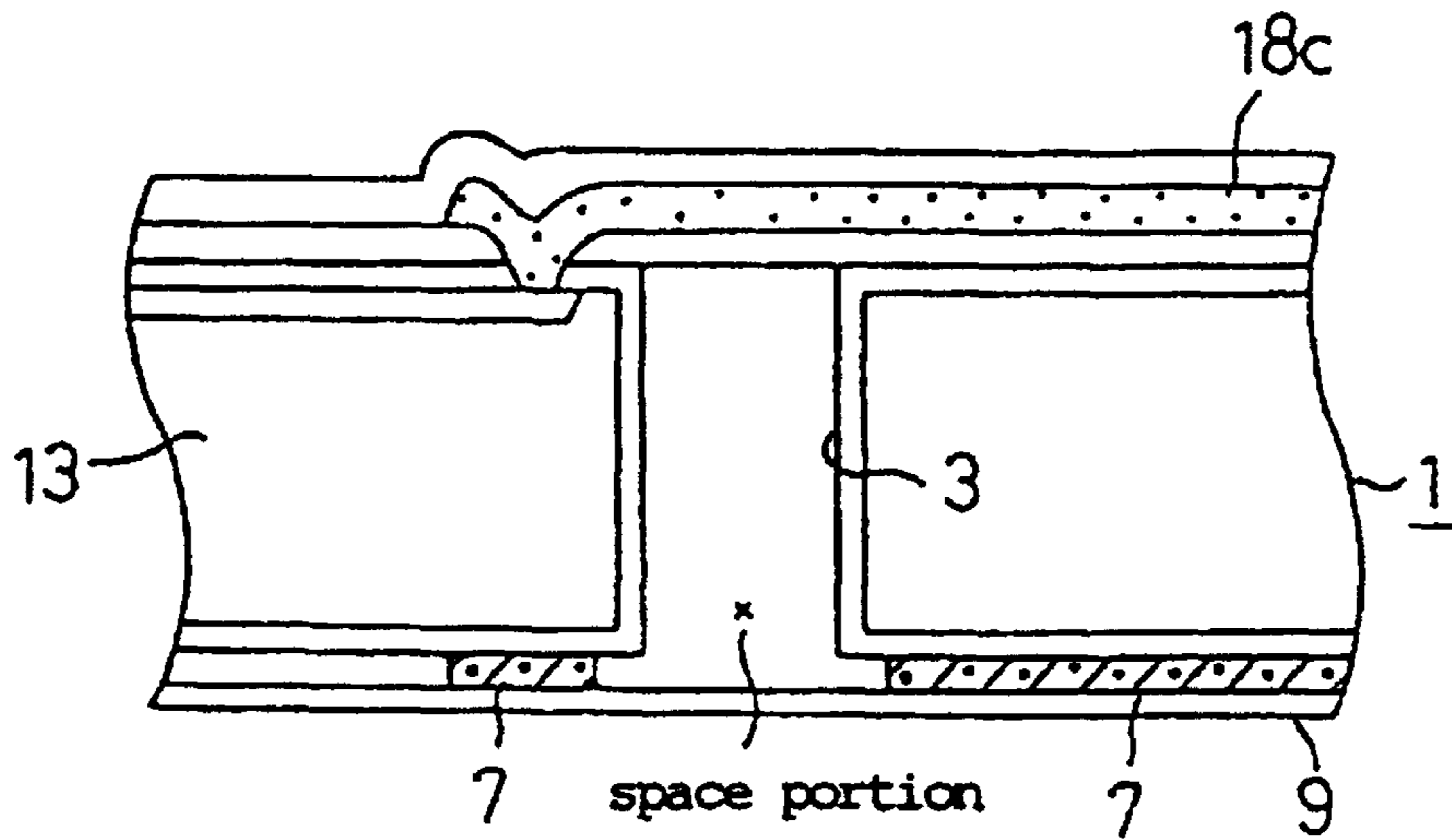

FIG. 12

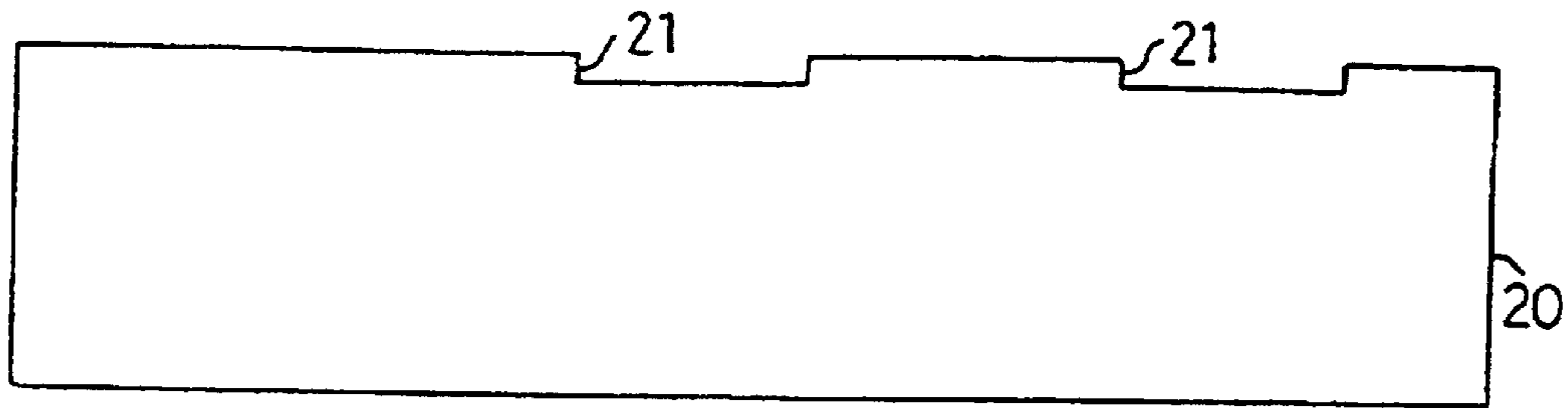

FIG. 13

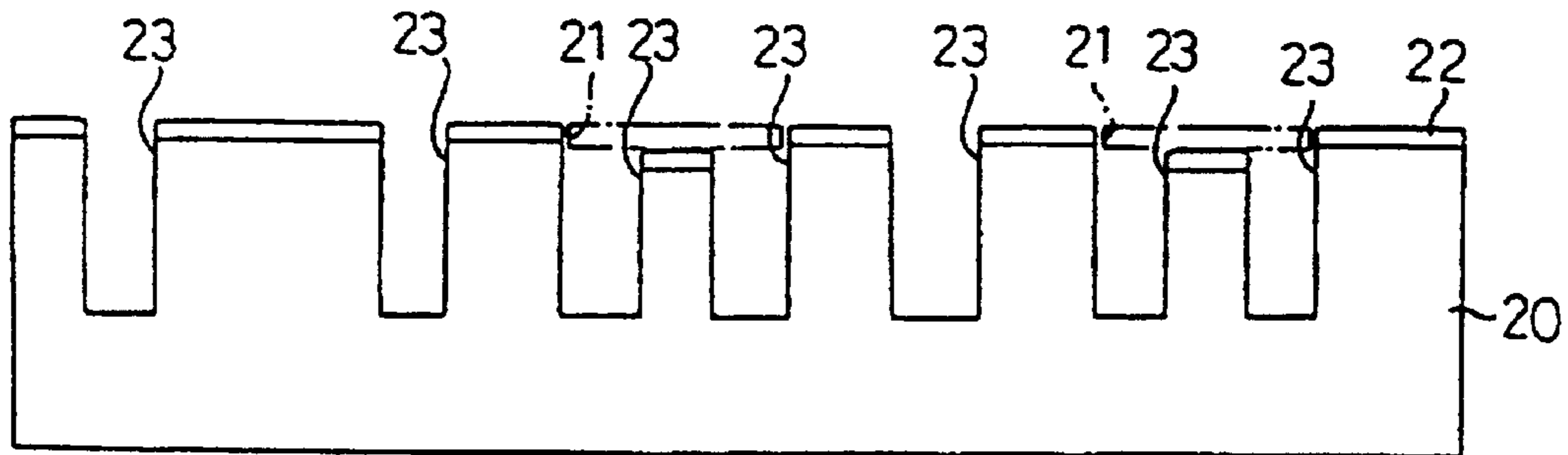

FIG. 14

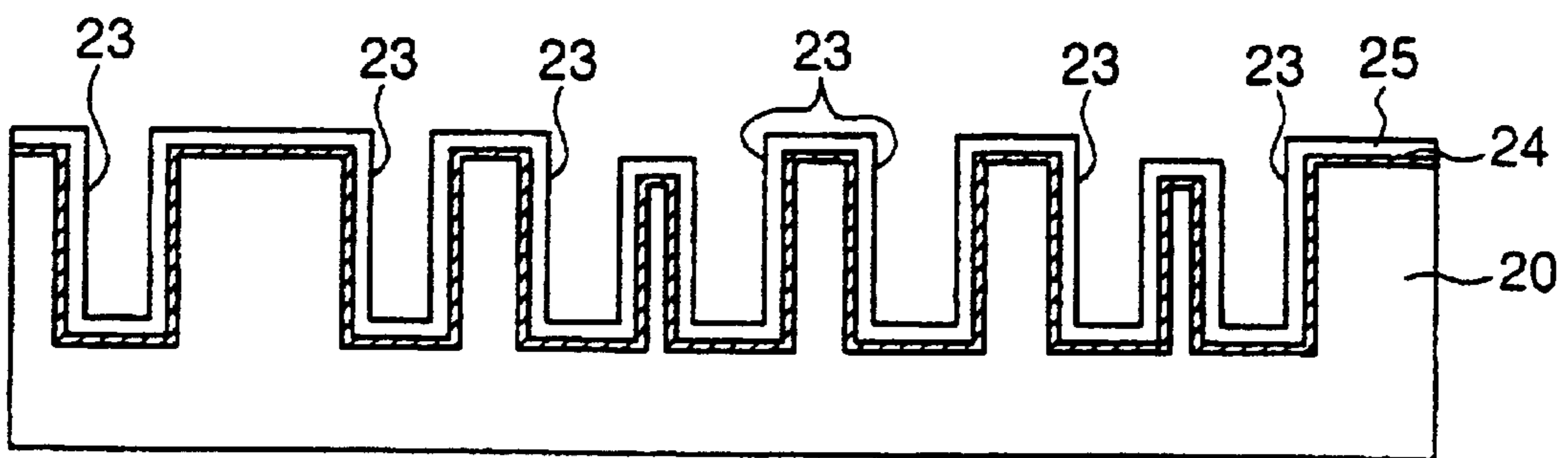

FIG. 15

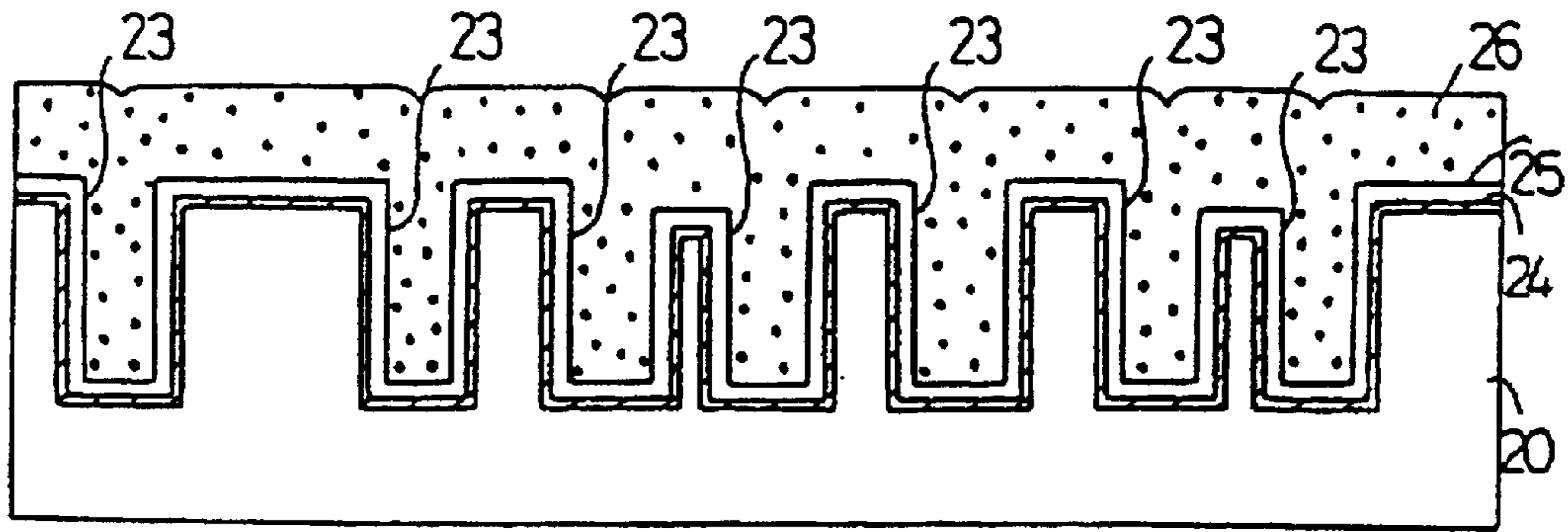

FIG. 16

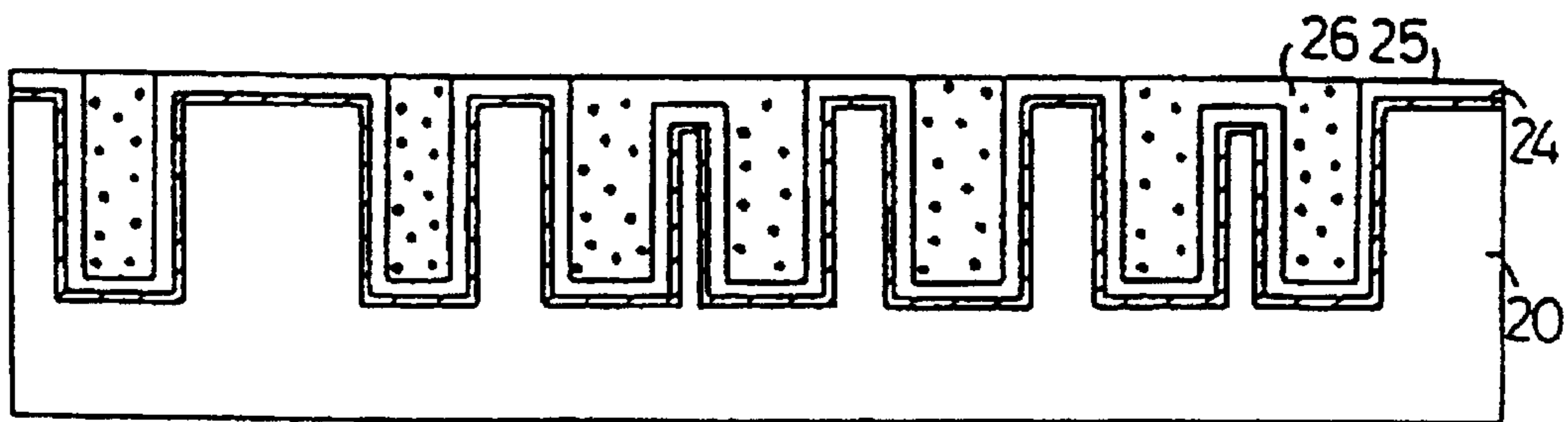

FIG. 17

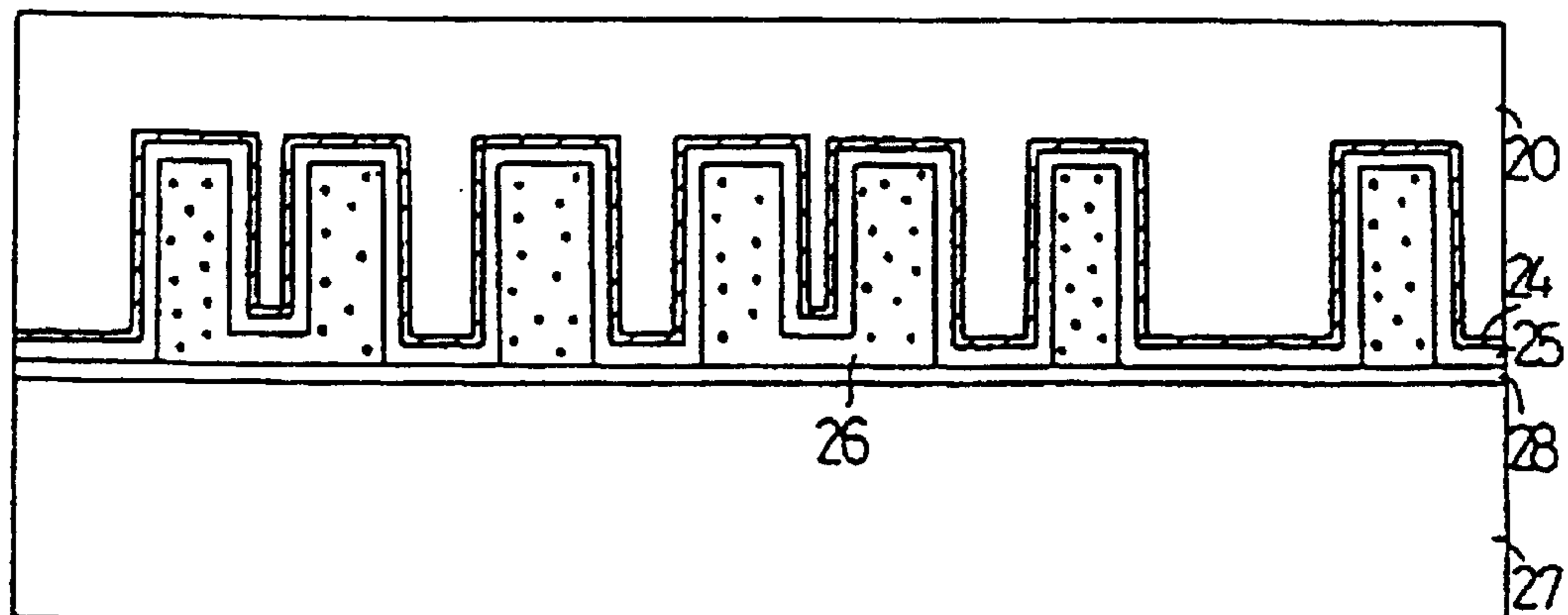

FIG. 18

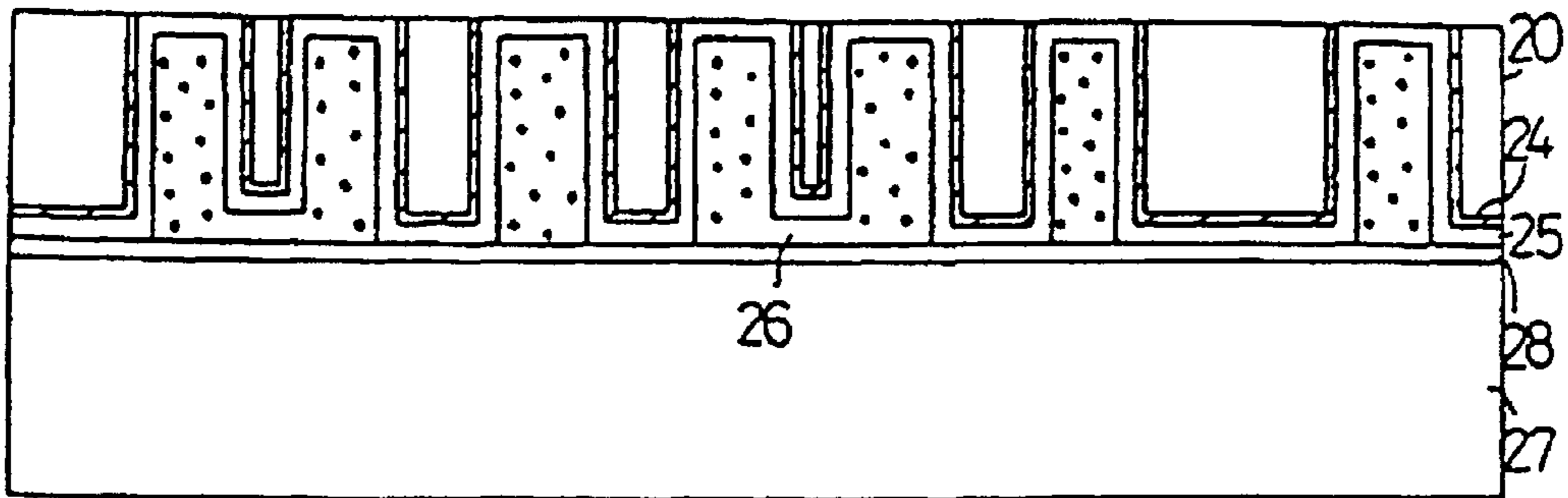

FIG. 19

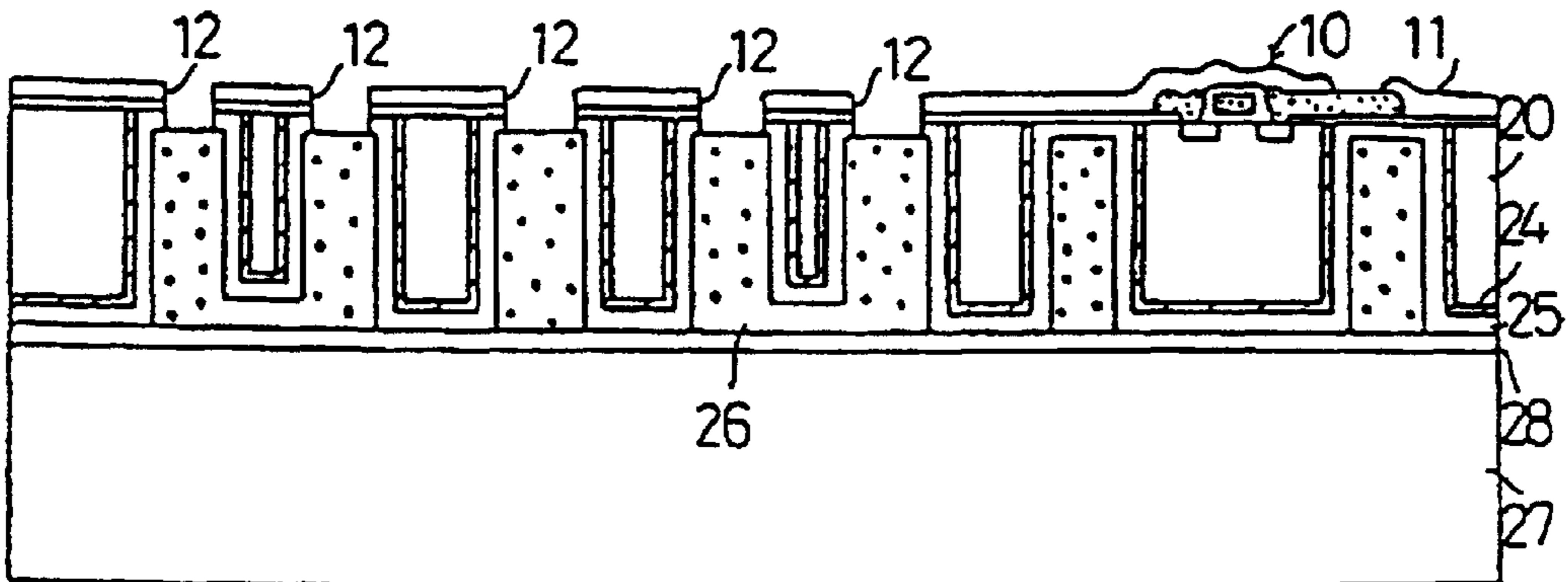

FIG. 20

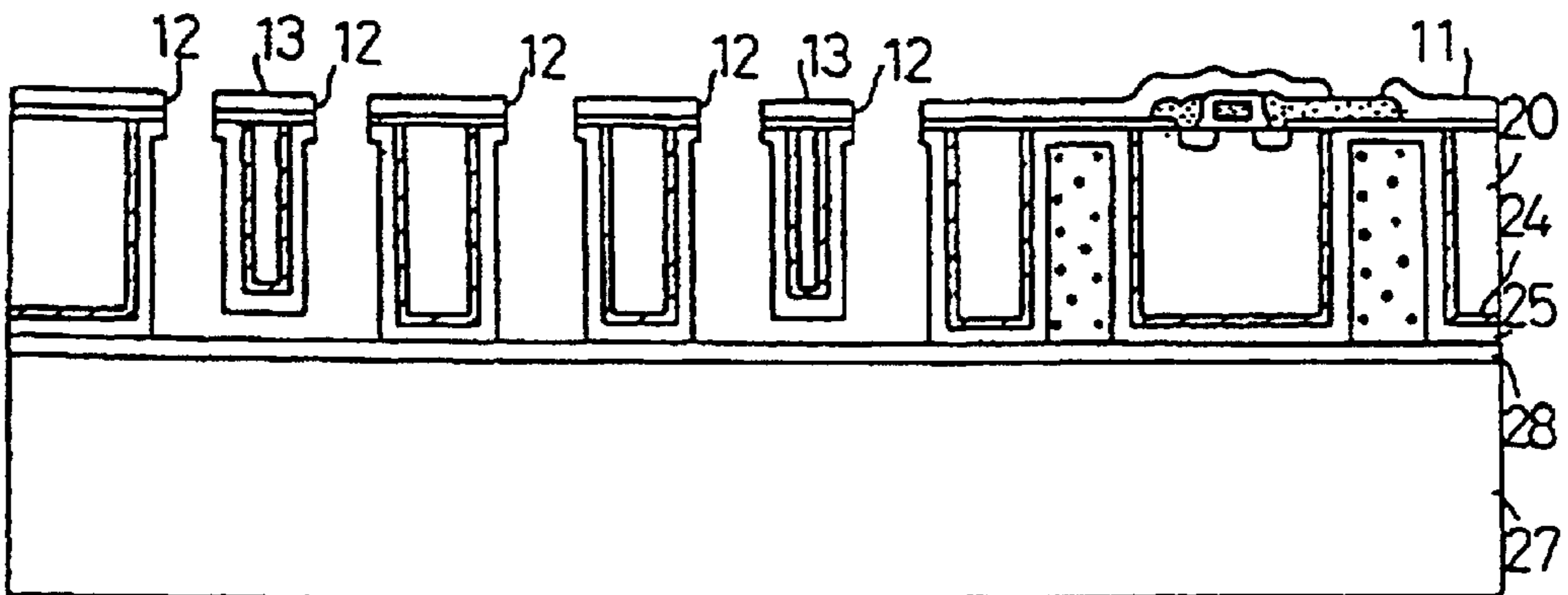

FIG. 21

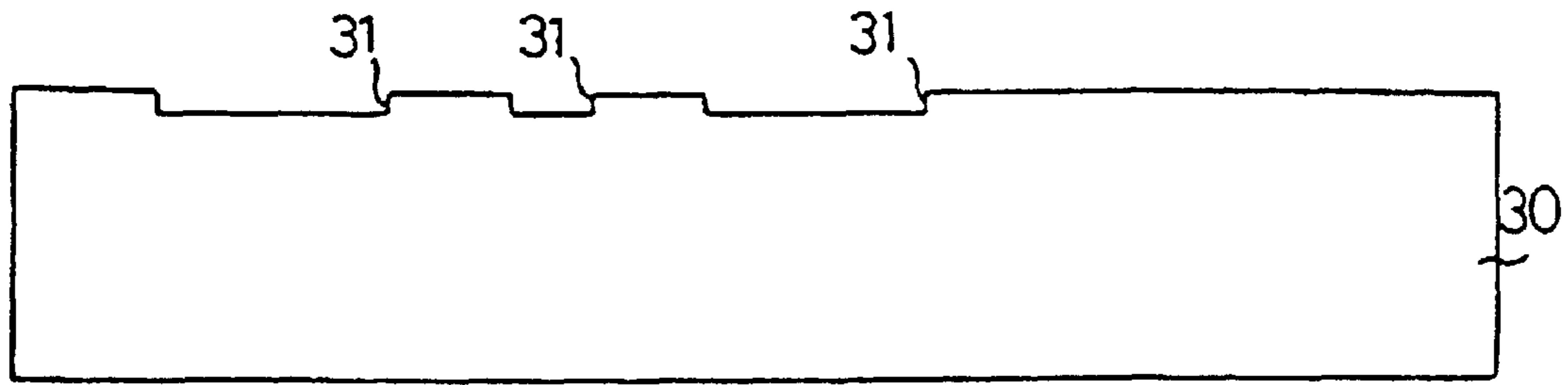

FIG. 22

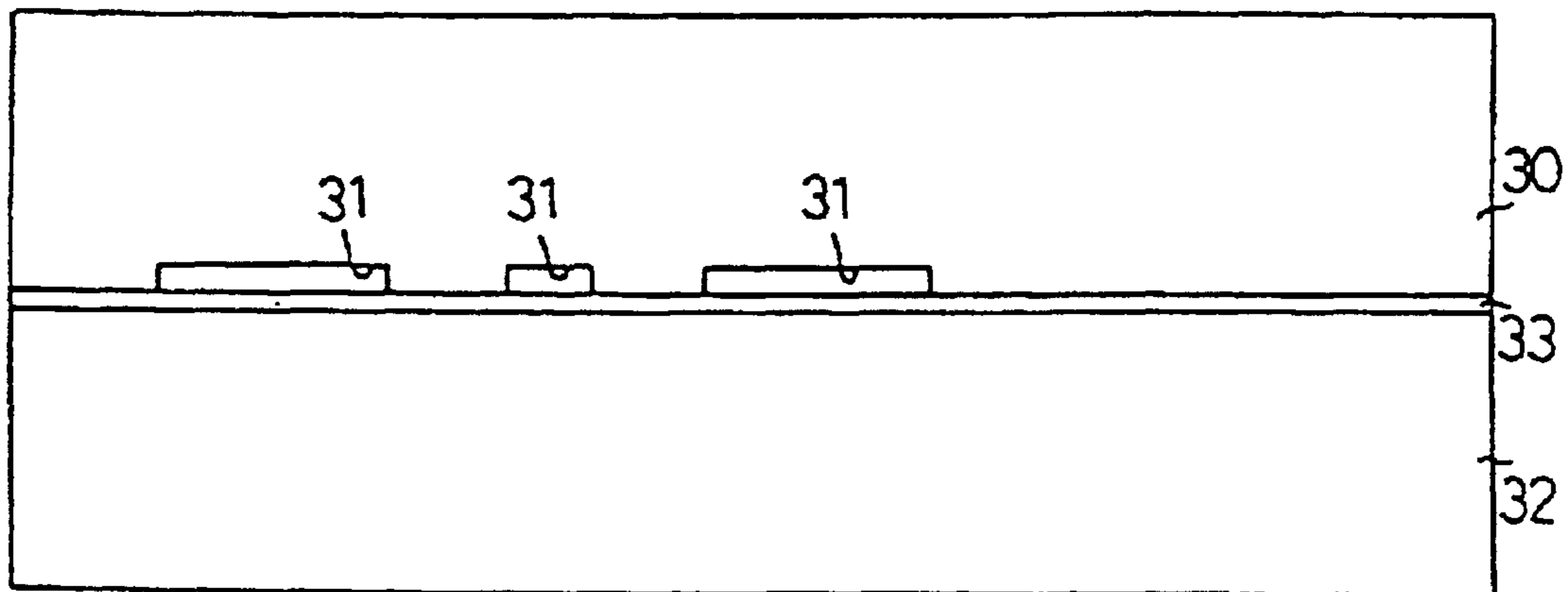

FIG. 23

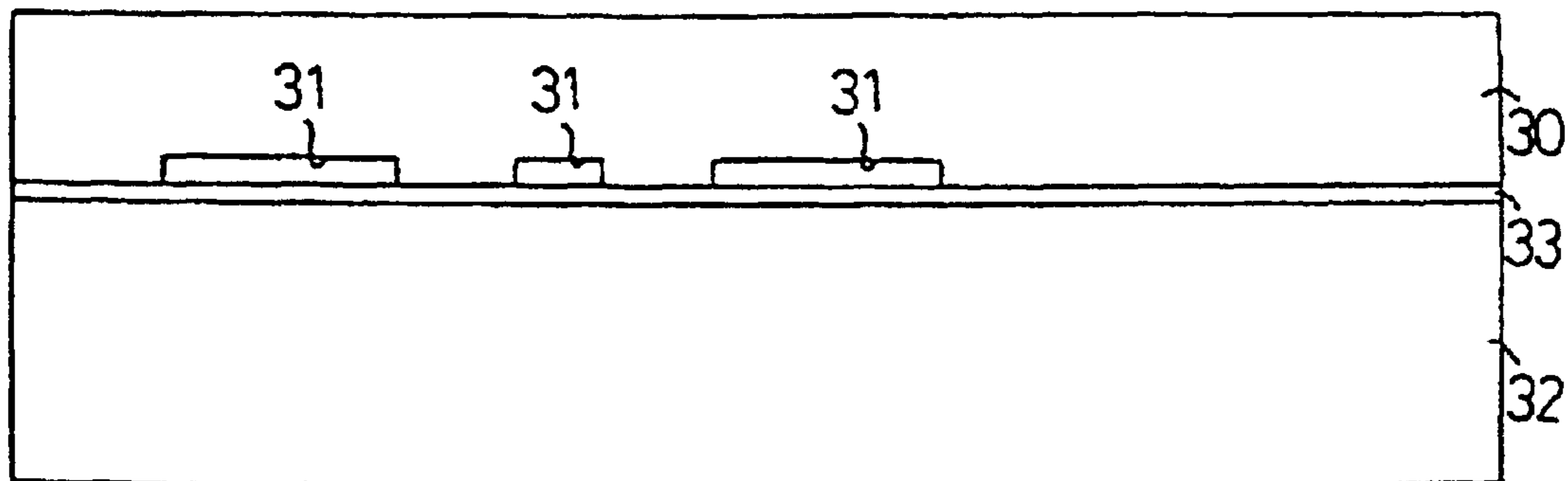

FIG. 24

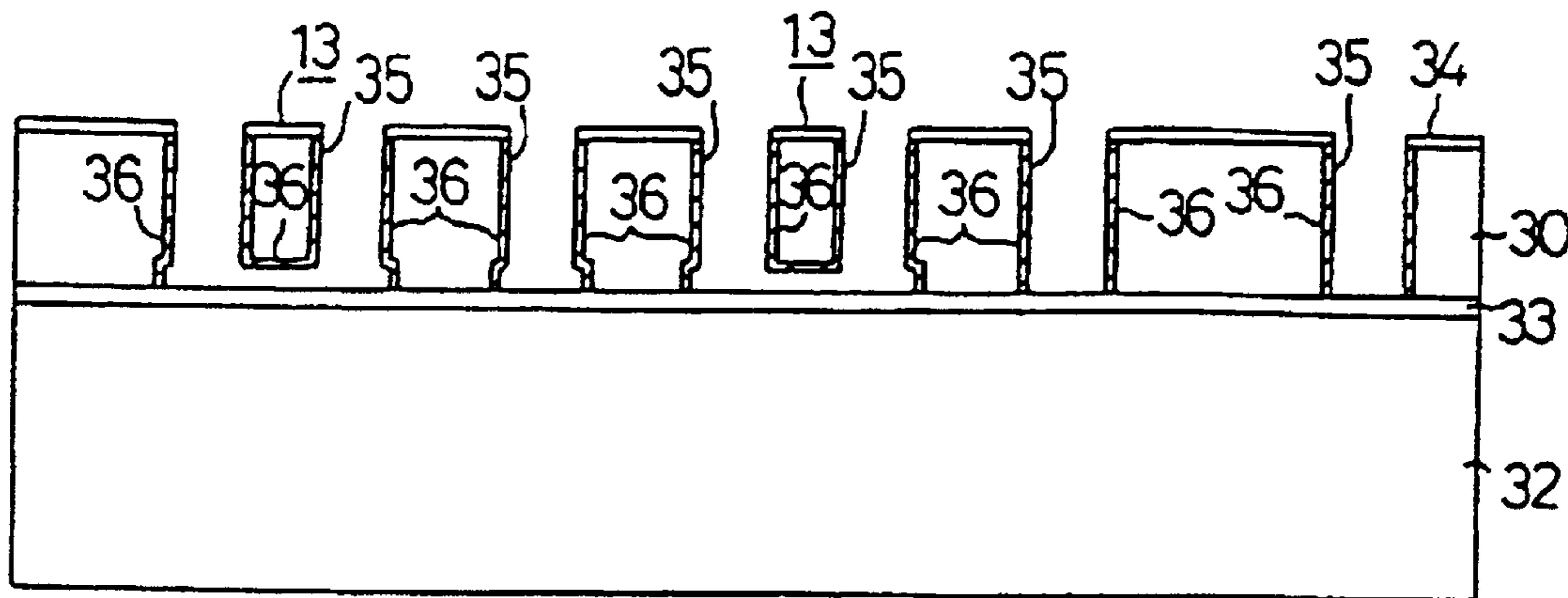

FIG. 25

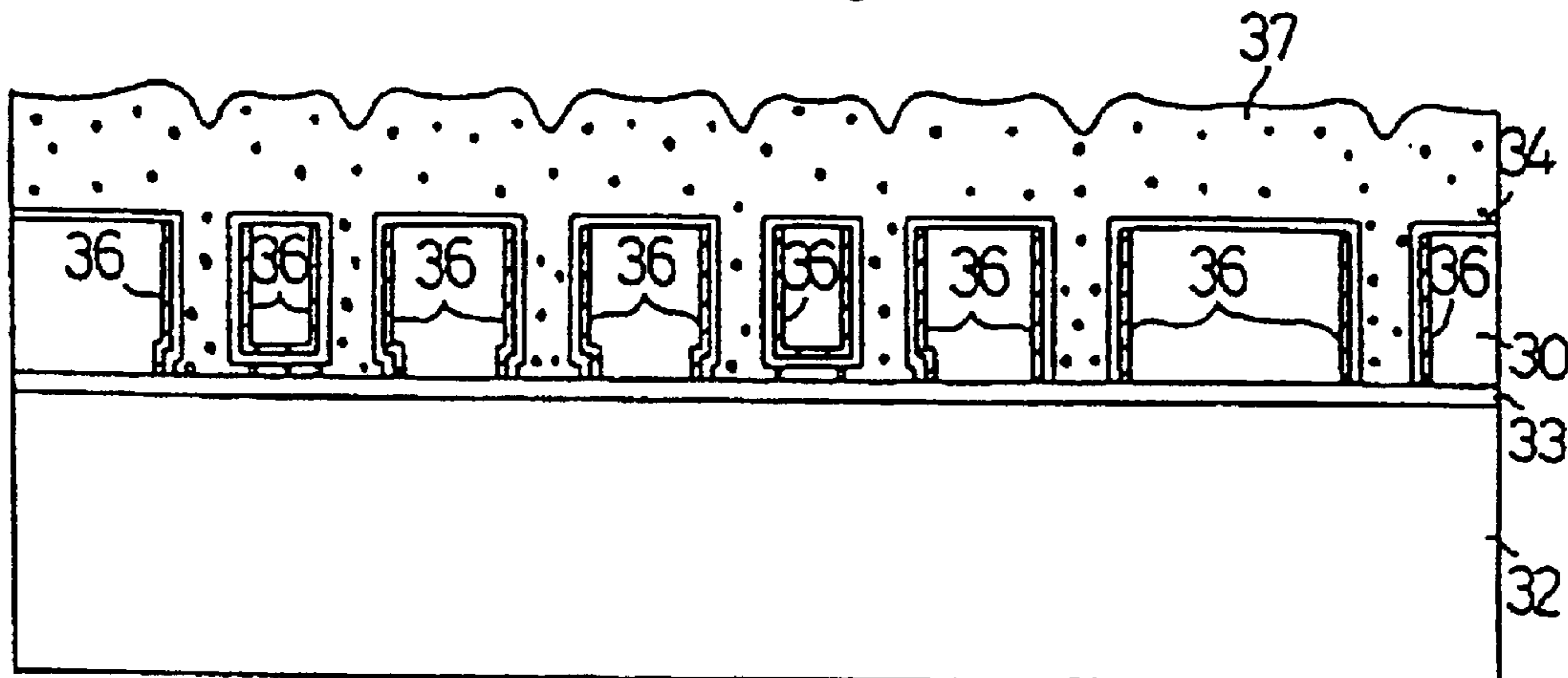

FIG. 26

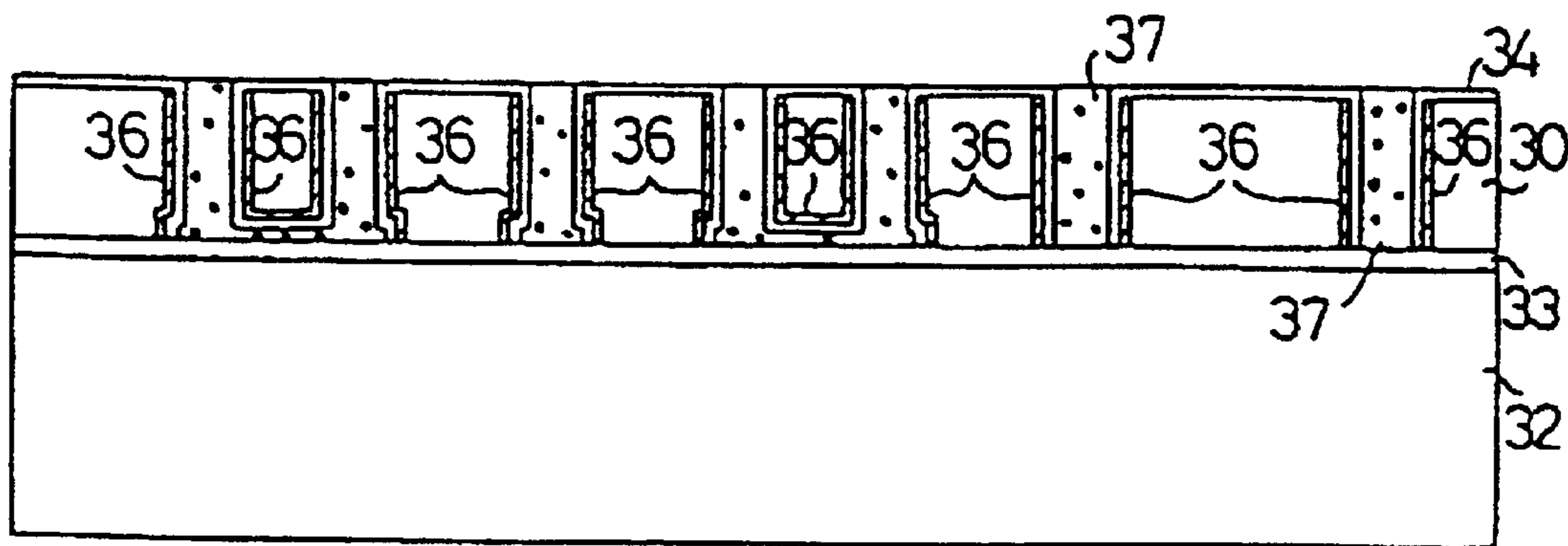

FIG. 27

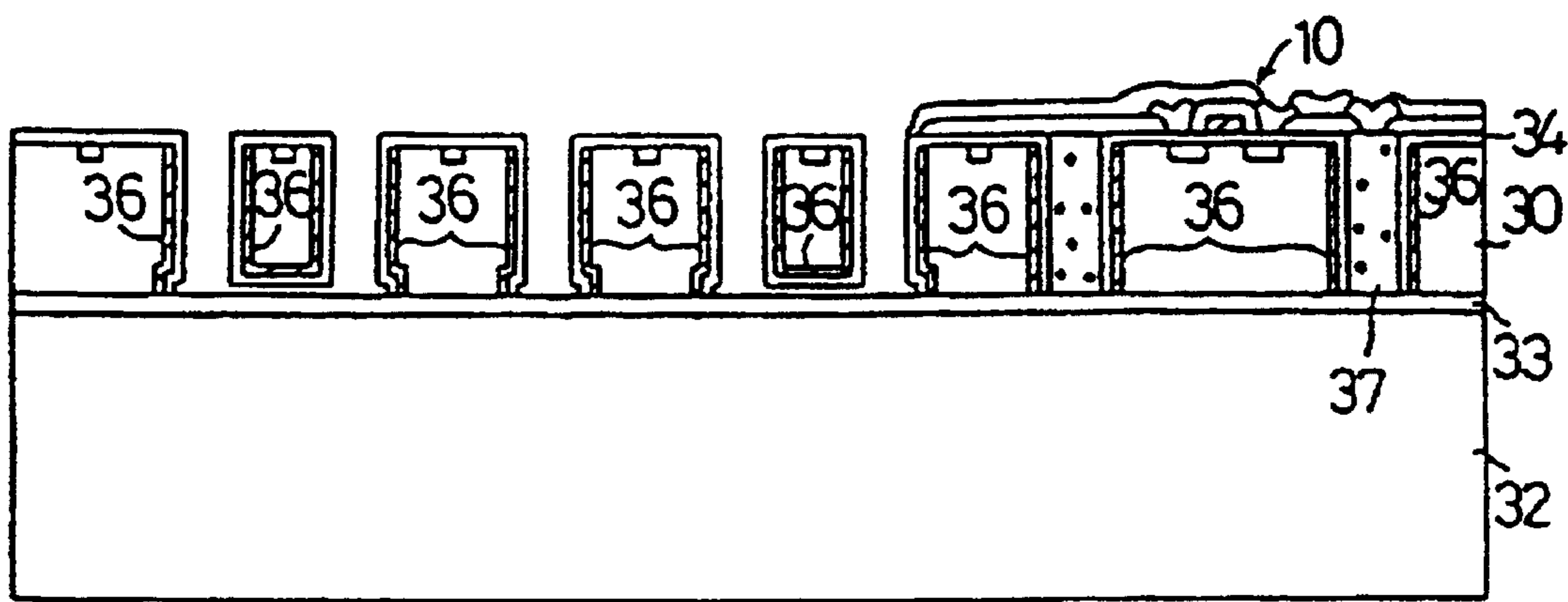

FIG. 28

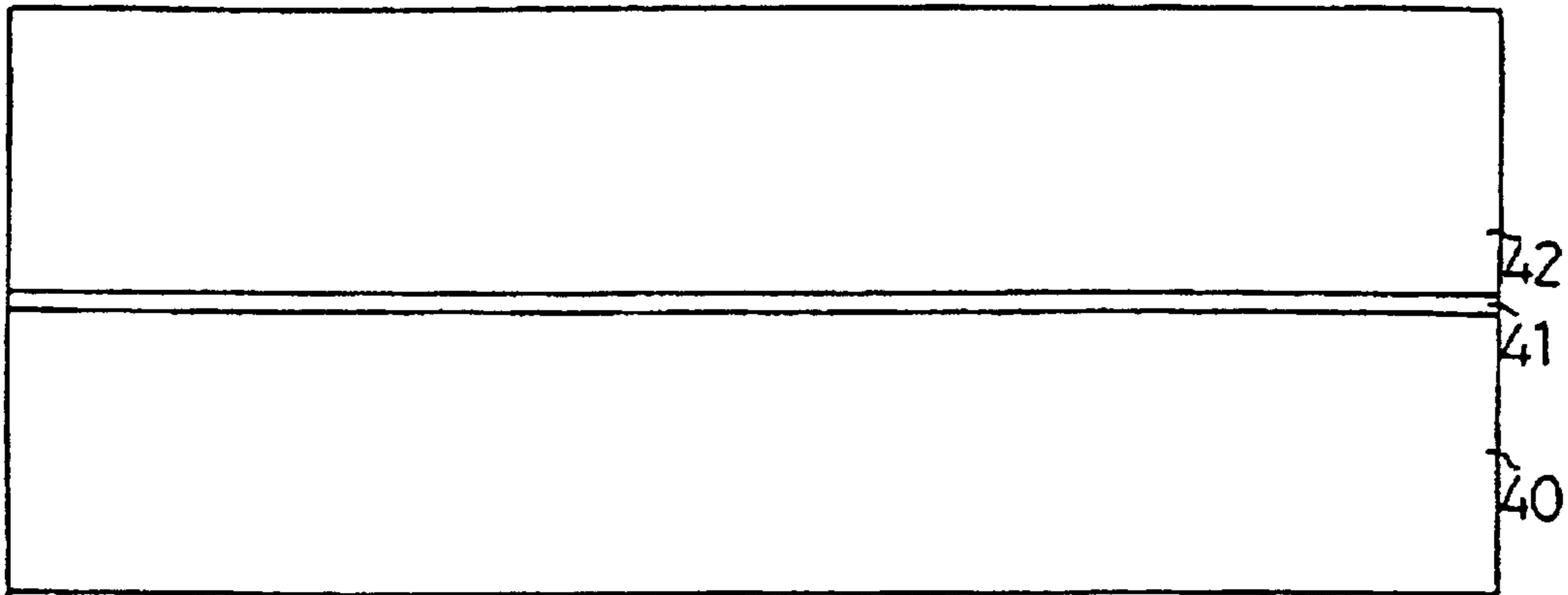

FIG. 29

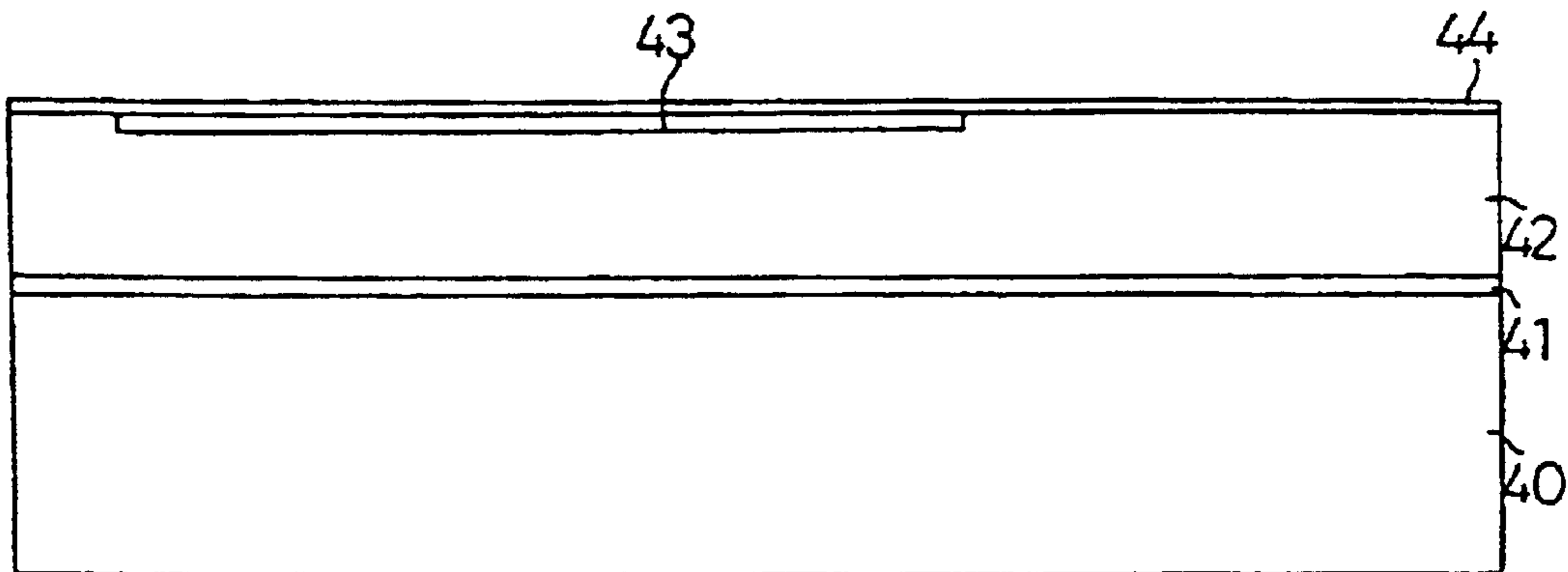

FIG. 30

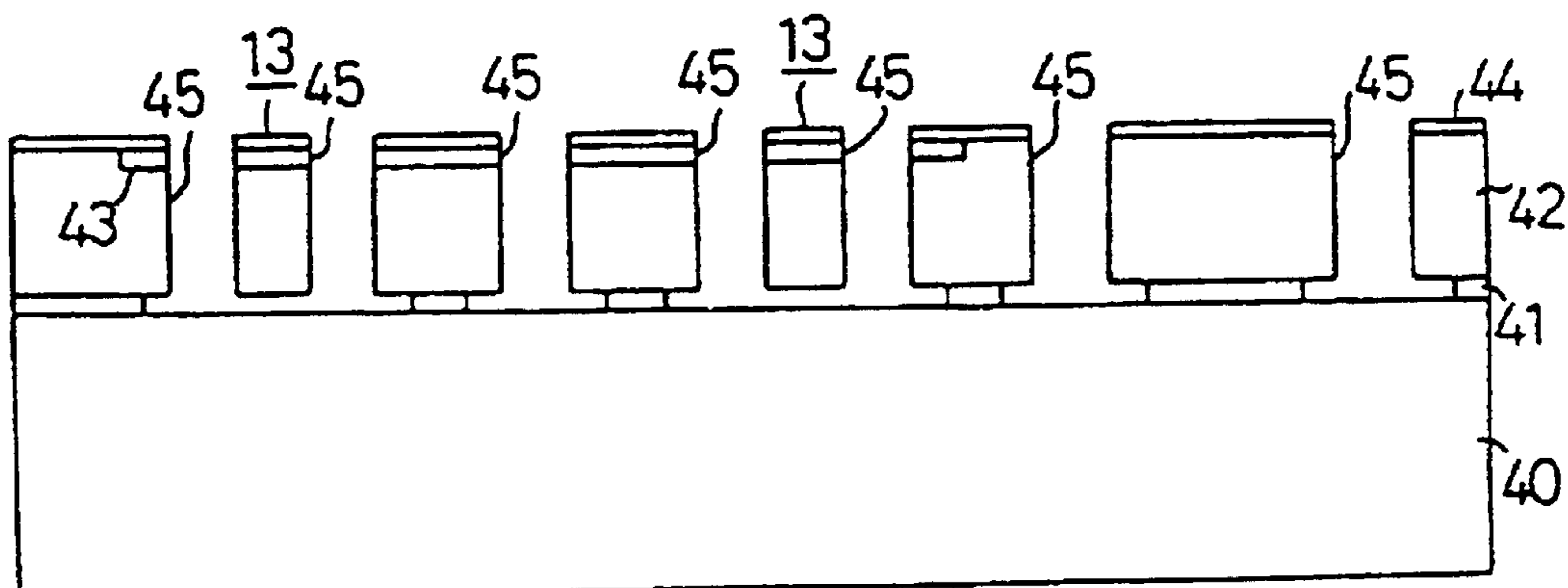

FIG. 31

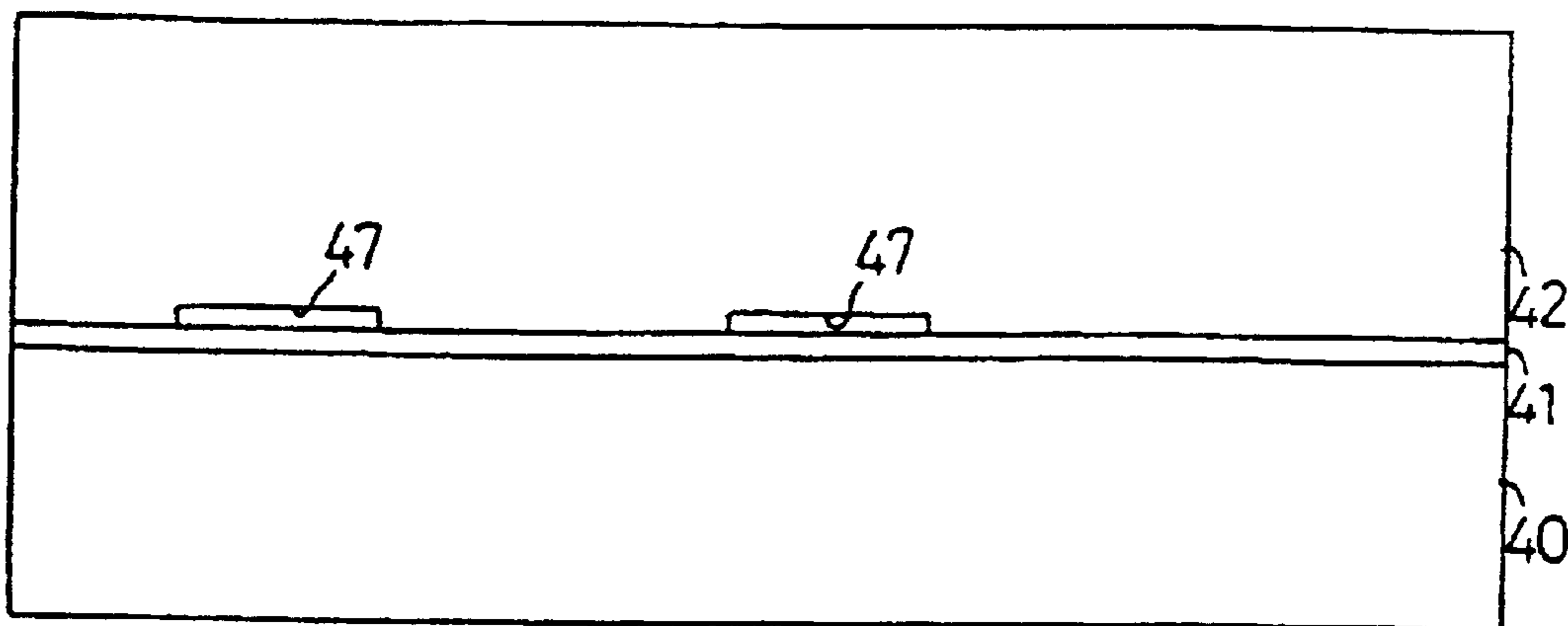

FIG. 32

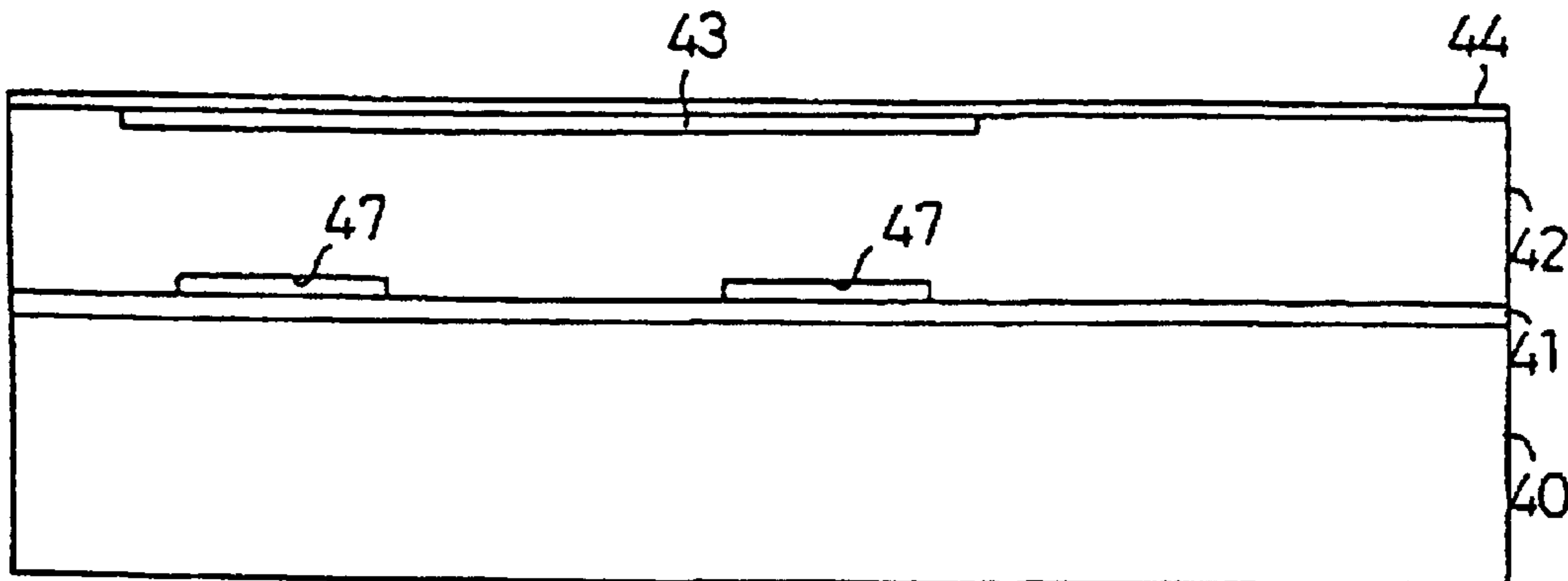

FIG. 33

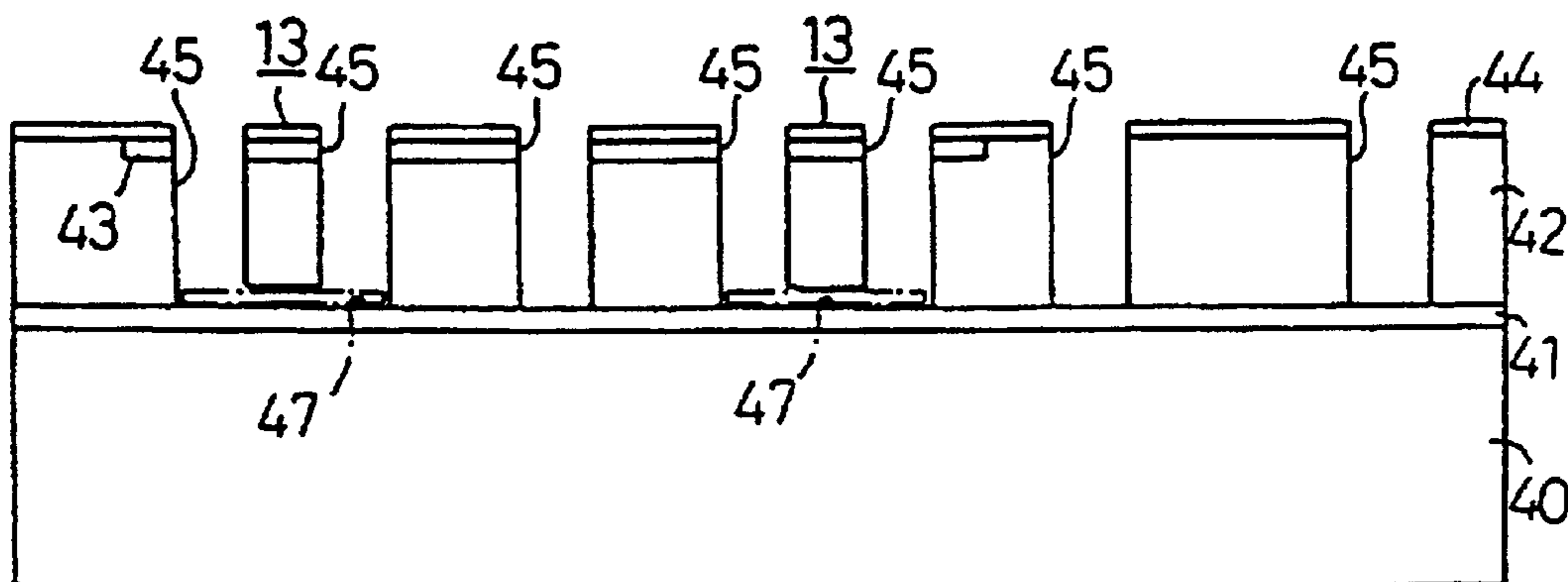

FIG. 34

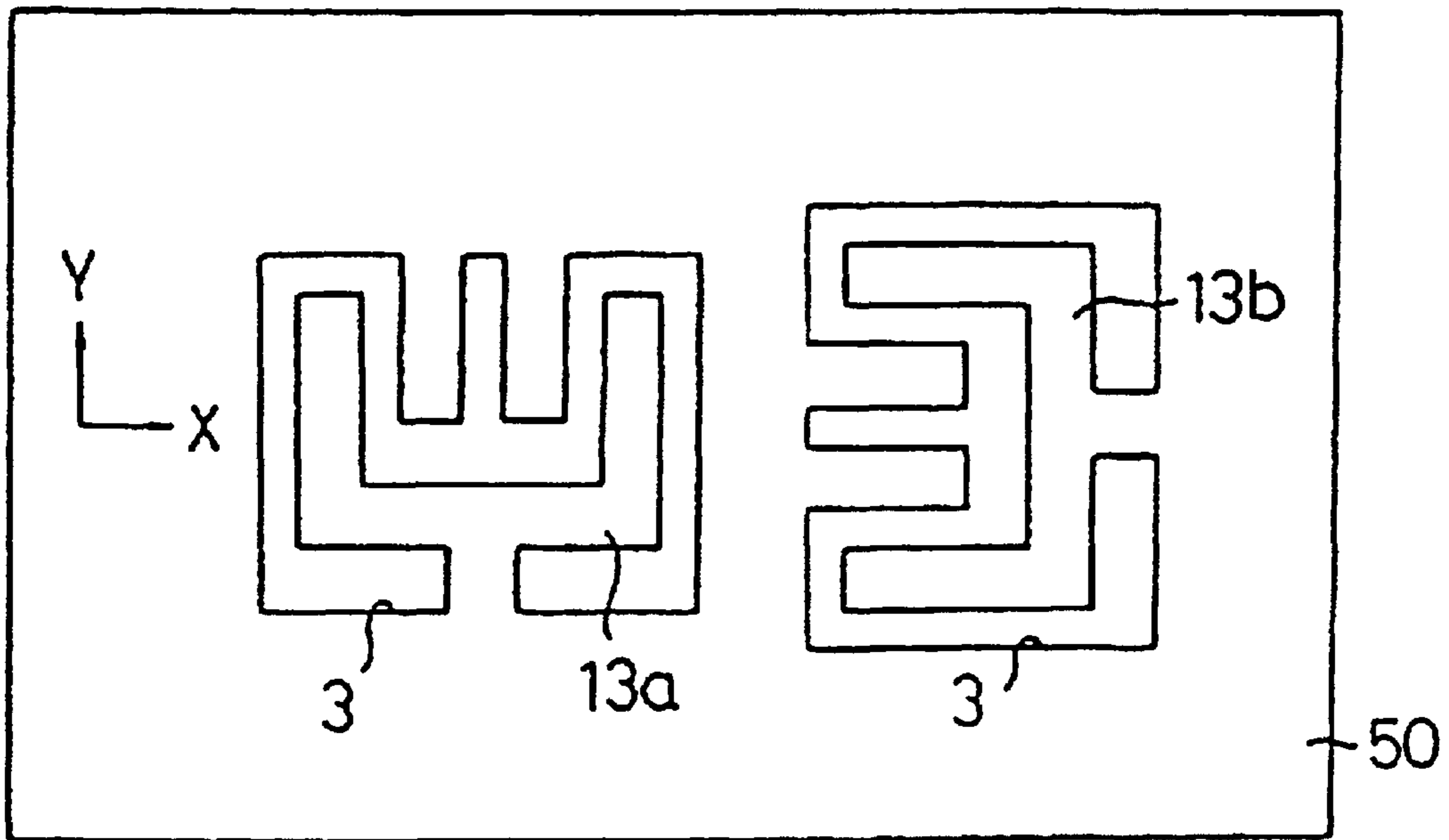

FIG. 35

ACCELERATION SENSOR AND PROCESS FOR THE PRODUCTION THEREOF

Matter enclosed in heavy brackets [] appears in the original patent but forms no part of this reissue specification; matter printed in italics indicates the additions made by reissue.

This application is a Re-Issue Application of U.S. Pat. No. 6,227,049.

Notice: More than one reissue application has been filed for reissue of U.S. Pat. No. 6,227,049. The reissue applications are application Ser. Nos. 10/123,220 (the present application), 10/315,566, 10/315,859, 10/315,827, 10/315,861, all of which are Divisional reissues of U.S. Pat. No. 6,227,049.

This is a continuation of application Ser. No. 08/167,976, filed on May 11, 1994, now abandoned.

BACKGROUND OF THE INVENTION

1. Field of the Invention

The present invention relates to an acceleration sensor, and more specifically, a semiconductor type acceleration sensor suitable for a air-bag system, a suspension control system, or the like, for automobiles.

2. Description of the Related Art

In producing a semiconductor type acceleration sensor, the movable part thereof has hitherto been prepared in such a way that it penetrates a single crystal silicon wafer. Accordingly, the movable part must be sized so as to penetrate through the thickness of a wafer, and therefore, it has been difficult to miniaturize the acceleration sensor. In addition, in order to incorporate this sensor into a package, a relaxation part, have been required such as a pedestal, in order to release the stress caused by the difference in coefficients of thermal expansion or the like.

However, in Nikkei Electronics, Nov. 11, 1991 (No. 540), pp 223 to 231, there is illustrated an acceleration sensor produced by use of a surface micro-machining technique. According to this technique, a thin polysilicon film is laminated on a silicon substrate, and this polysilicon film is etched, whereby a beam movable parallel to the surface of the substrate is formed, so as to form a differential capacity type acceleration sensor. However, when a beam structure is formed by use of polysilicon, if a signal processing circuit is formed around the formed beam structure, the sensor characteristics become unstable. This is because the beam structure is formed of a polycrystalline and amorphous material, resulting in noticeable variation for every production lot. Accordingly, it is still desirable to form an acceleration sensor by surface micro-machining single crystal silicon.

Under such circumstances, the purpose of the present invention is to provide an acceleration sensor having a novel structure, by which high precision and high reliability can be realized.

In addition, another purpose of the present invention is to produce this acceleration sensor with a good yield rate during the production process thereof.

SUMMARY OF THE INVENTION

The gist of a first embodiment of the present invention resides in an acceleration sensor, comprising a second single crystal silicon substrate bonded onto a first single crystal silicon substrate with an insulating film interposed

therebetween, the second single crystal silicon substrate being made of a thin film, a beam formed on at least either of said first and second single crystal silicon substrates and movable in a direction parallel to the surface thereof, and a signal-processing circuit formed on at least one of said first and second single crystal silicon substrates for performing processing of signals produced by a movement of beam, caused by an acceleration.

In addition, the gist of a second embodiment of the present invention resides in a process for producing an acceleration sensor, comprising: a first step of forming, on a main surface of a first single crystal silicon substrate, a groove with a predetermined depth for formulation of a beam; a second step of forming, on the main surface of said first single crystal silicon substrate, a film of a polycrystalline silicon, an amorphous silicon or a mixture thereof so as to fill said groove with said silicon film; a third step of bonding the main surface of said first single crystal silicon substrate to a second single crystal silicon substrate with an insulating film formed thereon, said insulating film being interposed between said first and second single crystal silicon substrates; a fourth step of polishing the reverse side of said first single crystal silicon substrate to a predetermined degree, so as to make said first single crystal silicon substrate a thin film; and a fifth step of forming a signal-processing circuit on at least either of said first and second single crystal silicon substrates, and thereafter, removing by etching said silicon film of a polycrystal silicon, an amorphous silicon or a mixture thereof from said reverse side of said first single crystal silicon substrates, to form a beam.

In addition, the gist of a third embodiment of the present invention resides in a process for producing an acceleration sensor, comprising: a first step of bonding a main surface of a first single crystal silicon substrate to a second single crystal silicon substrate with an insulating film formed thereon, said insulating film being interposed therebetween; a second step of polishing the reverse side of said first single crystal silicon substrate to a predetermined degree, so as to make the first single crystal silicon substrate a thin film; a third step of forming a groove with a predetermined depth for formulation of a beam; a fourth step of forming, on the reverse side of said first single crystal silicon substrate, a film of a polycrystal silicon, an amorphous silicon or a mixture thereof, so as to fill said groove with said silicon film, and smoothing the surface of said silicon film; and a fifth step of forming a signal-processing circuit on at least one of said first and second single crystal silicon substrates, and thereafter, removing by etching said film of polycrystal silicon, amorphous silicon or a mixture thereof from the reverse side of the first single crystal silicon substrate, to form a beam.

In the first embodiment, when an acceleration is applied in a direction parallel to the surface of the bonded single crystal silicon substrates, the beam formed on the first or second single crystal silicon substrate moves. As this beam moves, signal processing is performed in the signal-processing circuit formed on the first or second single crystal silicon substrate.

In the second embodiment, as a first step, a groove of a predetermined depth for formation of a beam is formed on the main surface of the first single crystal silicon substrate, and as a second step, a film of a polycrystalline silicon, an amorphous silicon or a mixture thereof is formed on the main surface of the first single crystal silicon substrate, whereby the groove is filled with the silicon film, and the surface of this silicon film is flattened. Subsequently, as a third step, the main surface of the first single crystal silicon

substrate is bonded to a second single crystal silicon substrate having an insulating film formed thereon, said insulating film being interposed between the first and second single crystal substrates, and, as a fourth step, the reverse side of the first single crystal silicon substrate is polished to a predetermined degree, whereby the first single crystal silicon substrate is made into a thin film. Subsequently, as a fifth step, a signal-processing circuit is formed on the first or second single crystal silicon substrate, thereafter the polycrystalline, amorphous or mixed silicon film is removed by etching from the reverse side of the first single crystal silicon substrate, and a beam is formed. As a result, an acceleration sensor according to the first invention is produced.

In the third embodiment, as a first step, the main surface of a first single crystal substrate is bonded to a second single crystal silicon substrate with an insulating film formed thereon, said insulating film being interposed between the first and second substrates, and as a second step, the reverse side of the first single crystal silicon substrate is polished to a predetermined degree, so that the first single crystal silicon substrate is made into a thin film. Subsequently, as a third step, a groove of a predetermined depth for formation of a beam is formed on the reverse side of the first single crystal silicon substrate, and as a fourth step, a film of polycrystalline silicon, an amorphous silicon or a mixture thereof is formed on the reverse side of the first single crystal silicon substrate, whereupon the groove is filled with the silicon film, and the surface of the silicon film is flattened. Subsequently, as a fifth step, a signal-processing circuit is formed on the first or second single crystal silicon substrate, whereafter the polycrystalline, amorphous or mixed silicon film is removed by etching from the reverse side of the first single crystal silicon substrate, and a beam is formed. As a result, an acceleration sensor according to the first embodiment is produced.

BRIEF DESCRIPTION OF THE DRAWINGS

FIG. 1 is a plan of an acceleration sensor according to the first embodiment of the present invention;

FIG. 2 is a cross section taken along line 2—2 in FIG. 1;

FIGS. 3 to 10 are illustrations for explanation of the manufacturing process of the first embodiment, and, respectively, a sectional view for each production stage;

FIG. 11 is a plan illustrating an application example of the first embodiment;

FIG. 12 is a sectional view taken along the line 12—12 in FIG. 11;

FIGS. 13 to 21 are illustrations for explanation of the manufacturing process of the second embodiment, and, respectively, a sectional view for each production stage;

FIGS. 22 to 28 are illustrations for explanation of the manufacturing process of the third embodiment, and, respectively, a sectional view for each production stage;

FIGS. 29 to 31 are illustrations for explanation of the manufacturing process of the fourth embodiment, and, respectively, a sectional view for each production stage;

FIGS. 32 to 34 are illustrations for explanation of the manufacturing process examples to which the fourth embodiment is applied, and, respectively, a sectional view for each production stage;

FIG. 35 is a plan illustrating an example of a sensor tip formed by an acceleration sensor according to the present invention.

DETAILED DESCRIPTION OF THE PREFERRED EMBODIMENTS OF THE INVENTION

In the following, the embodiments and realizations of the present invention, will be explained with reference to the attached drawings.

First Embodiment

FIG. 1 is a plain view plan of an acceleration sensor produced by the first embodiment of the present invention, and FIG. 2 is a sectional view taken along line 2—2 in part and the signal-processing circuit are formed of the same single crystal silicon substrate.

The present acceleration sensor is a capacity type acceleration sensor. As illustrated in FIG. 2, there is bonded onto a single crystal silicon substrate 8 a single crystal silicon substrate 1 through an SiO₂ film 9, and in the single crystal silicon substrate 1, there is formed a cantilever 13 by a trench 3 penetrating said substrate 1. As illustrated in FIG. 1, this cantilever 13 has a structure such that an end side thereof is branched into two parts. The cantilever 13 can be moved in a direction parallel to the surface of the single crystal silicon substrate 1 (the arrow direction C in FIG. 1). In addition, in the single crystal silicon substrate 1, a signal-processing circuit 10 is formed and is electrically insulated from the cantilever 13 by a polysilicon film 6 and an SiO₂ film 5.

In the following, the production process of the first embodiment of the present invention, which is suitable for the production of the aforesaid structure, will be explained with reference to FIGS. 3 to 10.

First, as illustrated in FIG. 3, an n-type (100) single crystal silicon substrate 1 with a resistance of 1 to 20Ω-cm is provided, and on the main surface thereof, there is formed an SiO₂ film 2 with a thickness of about 1 μm by thermal oxidation, and the SiO₂ film 2 is formed into a predetermined pattern by a photolithographic method. This pattern is a pattern exposing, on the main surface of the silicon substrate, an area to be formed as a groove separating at least an area to be formed as a movable electrode (cantilever) from the substrate, and in the present embodiment, this pattern is formed as a pattern exposing also the main surface of the silicon substrate in an area for transversely insulating and separating the signal-processing circuit. Subsequently, on the main surface side of the single crystal silicon substrate 1, there is formed a trench 3 having a perpendicular wall with a predetermined depth, e.g. ranging from about 0.2 to about 30 μm. In the present embodiment, explanation will be made with respect to the case where the wall thickness is about 3 μm.

Substantially, after the SiO₂ film 2 has been removed, as illustrated in FIG. 4, an n⁺ diffused layer 4 formed using phosphorus, arsenic or the like is formed on the main surface of the single crystal silicon substrate 1, including the internal wall of the trench 3, and further, an SiO₂ film 5 with a thickness ranging from 0.1 to 1 μm is formed by thermal oxidation or the like. In this case, in order to prevent damage by etching, there may be conducted the so-called "sacrifice oxidation" in which SiO₂ is formed by thermal oxidation and removed before formulation of the n⁺ diffused layer 4.

Substantially, as illustrated in FIG. 5, a polysilicon film 6 is formed on the main surface of the single crystal silicon substrate 1, and the trench 3 is filled with the polysilicon film 6. In addition, in the case where an impurity is introduced into the polysilicon film 6 in order to use the polysilicon film 6 as a conductive path, forming a thin polysilicon layer and diffusing phosphorus or the like in a high concentration before formation of the polysilicon film 6, allows the impurity to be introduced into the polysilicon film 6.

Next, as illustrated in FIG. 6, the surface of the polysilicon film 6 is mirror finished, so as to make the thickness of the polysilicon film 6 a predetermined value. Subsequently, boron ions or other impurity are implanted into the polysilicon film 6 to form p⁺ diffused layers 7 in predetermined areas.

5

On the other hand, as illustrated in FIG. 7, another (100) single crystal silicon substrate **8** is provided, and an SiO₂ film **9** with a thickness ranging from 0.1 to 1.0 μm is formed on the main surface of the silicon substrate **8**.

Subsequently, the single crystal silicon substrate **1** and the single crystal silicon substrate **8** are dipped into e.g. an aqueous mixed solution of aqueous hydrogen peroxide and sulfuric acid, so as to subject these substrates to a hydrophilicity-imparting treatment. Thereafter, these substrates are dried, and as illustrated in FIG. 8, the main surface of the single crystal silicon substrate **1** and that of the single crystal silicon substrate **8** are put together at room temperature, and these substrates are introduced into a furnace at 400 to 1100° C. for a period of time ranging from 0.5 to 2 hours, so as to strongly bond them.

Subsequently, as illustrated in FIG. 9, by use of an aqueous solution of an alkali type, e.g. an aqueous KOH solution or the like, the reverse side of the single crystal silicon substrate **1** is subjected to selective polishing. The polishing is continued until the SiO₂ film **5** is exposed. As a result, the thickness of the single crystal silicon substrate **1** reaches a value which is approximately determined by the depth of the trench, e.g. about 3 μm, so that the substrate **1** is made thin.

Subsequently, as illustrated in FIG. 10, in a predetermined area of the single crystal silicon substrate **1**, there is formed a signal-processing circuit **10** (IC circuit portion) by use of an ordinary CMOS process, bipolar process or the like. In addition, a diffused layer for connecting to wiring and a metallic electrode film composed of an aluminum film or the like are formed, and wiring at the sensor part, wiring at the circuit part, and connection of the sensor part to the circuit part are performed. In FIG. 1 and FIG. 10, a MOS transistor alone is illustrated as a part of the signal-processing circuit **10**.

Further, on the upper surface of the signal-processing circuit **10**, there is formed, as a passivation film **11**, a plasma SiN film (P-SiN) e.g. by a plasma CD method. Subsequently, at the sensor part side, windows **12** are opened at predetermined areas of the passivation film **11**; and the polysilicon film **6** filled in the trench **3** is exposed from the surface. By this window opening procedure, the single crystal portions where a cantilever or fixed electrodes are to be formed are demarcated from the polycrystal portions embedded in the trench, on the surface of the substrate.

Subsequently, as illustrated in FIG. 2, by use of a 20% solution of TMAH (tetramethylammonium hydroxide) (CH₃)₄NOH, the polysilicon film **6** is removed by etching through the windows **12** of the passivation film **11**, from the reverse side (the upper side in FIG. 2) of the single crystalline silicon substrate **1**. In this case, the passivation film **11** (P-SiN), SiO₂ film **5**, aluminum wiring layer and p₊ diffused layer (p⁺ polysilicon film) **7** are hardly etched by the selective etching. Accordingly, the bonding of the single crystal silicon substrate to the lower single crystal silicon substrate **8** is secured through the p⁺ diffused layer (p⁺ polysilicon film) **7**.

In addition, if trenches **3** are preliminary formed also in the wide area of the cantilever **13** in FIG. 1, and etching windows **48** are provided simultaneously with the formulation of the windows **12**, in such a way that the etching windows **48** communicate with said trenches **3**, the polysilicon film **6** below the movable part (cantilever **13**) of the sensor can be more securely removed by etching through this etching window **48** when the polysilicon film **6** is removed by etching.

6

By the aforesaid procedures, the cantilever **13** is formed. In this case, the cantilever **13** becomes, as illustrated in FIG. 2, smaller in the thickness L₂ in a direction parallel to the surface of the single crystal silicon substrate **1** than in the thickness L₁ in a direction along the depth of the single crystal silicon substrate **1**.

In a capacity type acceleration sensor, the end portions (bifurcated portions) of the cantilever **13** are formed as movable electrodes, and as illustrated in FIG. 1, the parts of the single crystal silicon substrate **1**, opposing the end portions of the cantilever **13**, are formed as fixed electrodes **14**, **15**, **16**, and **17**, respectively. In addition, as illustrated in FIG. 1, fixed electrode **14** and fixed electrode **16** are derived through an aluminum wiring layer **18a**, fixed electrode **15** and fixed electrode **17** are derived through an aluminum wiring layer **18b**, and the cantilever **13** (movable electrode) is derived through an aluminum wiring layer **18c**. These aluminum wiring layers **18a**, **18b**, and **18c** are connected to the signal-processing circuit **10**, and by this signal-processing circuit **10**, signal processing is conducted as the cantilever (movable electrode) **13** is displaced owing to an acceleration. In addition, by the n⁺ diffused layers **4** (see FIG. 2) disposed on the cantilevers **13** (movable electrodes) and fixed electrodes **14**, **15**, **16**, and **17**, the electric potential is maintained at a constant value.

Although a capacity type acceleration sensor is made in the present embodiment, if a piezo resistance layer is formed at the surface of the root portion of the cantilever **13**, a piezo resistance type acceleration sensor can be formed. As a matter of course, if these two types of sensors are formed in a one and same substrate, the precision and reliability of the acceleration sensor can further be improved.

In the acceleration sensor thus produced, the single crystal silicon substrate **1** is bonded through an SiO₂ film to the single crystal silicon substrate **8**, so as to form an SOI structure. In addition, in the cantilever **13**, its thickness L₂ in a direction parallel to the surface of the single crystal silicon substrate **1** is smaller than the thickness L₁ in a direction of the depth of the single crystal silicon substrate **1**. Accordingly, the cantilever **13** becomes movable, on the surface of the single crystal silicon substrate **1**, in a direction parallel to the surface, whereby an acceleration to a direction parallel to the substrate surface is detected.

As mentioned in the foregoing, in the present embodiment, on the main surface of the single crystal silicon substrate **1**, there is formed a trench (groove) **3** of a predetermined depth for formulation of the cantilever **13** (the first step), and the polysilicon film **6** is formed on the main surface of the single crystal silicon substrate **1**, so as to fill the trench **3** with said polysilicon film **6**, and the surface of the polysilicon film **6** is flattened (smoothed) (the second step). Subsequently, the main surface of the single crystal silicon substrate **1** is bonded to the single crystal silicon substrate **8** with an SiO₂ film **9** (insulating film) formed thereon, through said SiO₂ film **9** being interposed between the substrates **1** and **8** (the third step), whereafter the reverse side of the single crystal silicon substrate **1** is polished to a predetermined degree, so as to make the single crystalline silicon substrate into a thin film (the fourth step). Subsequently, the signal-processing circuit **10** is formed on the surface of the single crystal silicon substrate, whereafter the polysilicon film **6** is removed by etching from the reverse side of the single crystal silicon substrate, so as to form the cantilever **13** (the fifth step).

Accordingly, during the process for the formation of the signal-processing circuit **10**, in the course of the wafer

process, the trench 3 in the surface portion of the single crystal silicon substrate, is filled with the polysilicon film 6, whereby contamination of the IC elements, contamination of production equipment, and degradation or deterioration of electrical properties accompanied therewith can be prevented. That is, in the wafer process, by contriving to prevent the surface structures such as concave portions or penetration holes from appearing on the wafer surface in the heat treatment, photolithographic treatment and the like, in the course of the process, it is possible to prevent contamination and the like, and to thereby stably provide acceleration sensors of high precision.

The thus produced acceleration sensor comprises the single crystal silicon substrate 1, which is bonded through an SiO₂ film (insulating film) to the single crystal silicon substrate 8, and which is made a thin film; the cantilever 13, which is formed on said single crystal silicon substrate 1 and which is movable in a direction parallel to the surface of the substrate; and the signal-processing circuit 10, which is also formed on the single crystal silicon substrate 1 and which performs signal processing as the cantilever 13 moves owing to an acceleration. When an acceleration is applied in a direction parallel to the surface of the single crystal silicon substrate 1, the cantilever formed on the single crystal silicon substrate 1 moves. As the cantilever 13 moves, signal-processing is performed by the signal-processing circuit 10 formed on the single crystal silicon substrate 1. In such a way as above, by a micro-machining technique using single crystal silicon, an acceleration sensor is formed, by the novel structure of which high precision and high reliability can be realized.

In addition, since the surface of the aforesaid cantilever 13 and the part of the single crystal silicon substrate 1, opposing said cantilever 13, are coated with the SiO₂ film (insulator) 5, electrode short-circuit in the capacity type acceleration sensor can previously be prevented. In addition, it suffices if at least either of the surface of the cantilever 13 or the part of the single crystal silicon substrate 1 opposing the cantilever 13 is coated with the SiO₂ film (insulator) 5.

Further, as an application of the present embodiment, as illustrated in FIGS. 11 and 12, the cantilever may be separated from the signal-processing circuit (IC circuit portion) 10 and an air bridge wiring is formed, in order to reduce parasitic capacity. In addition, the fixed electrodes 14, 15, 16, and 17 may be formed so as to have the same structure as above. This can be realized by forming a p₊ type polysilicon film 7 at the minimum position necessary for bonding the fixed electrodes to the lower substrate.

In addition, although an aluminum wiring layer is used in the aforesaid embodiment, the wiring part may be formed by use of a polysilicon layer. Further, although two movable electrodes are formed at the end of the beam and simultaneously, four fixed electrodes 14, 15, 16, and 17 are formed, in the aforesaid embodiment, the movable and fixed electrodes may be formed like the teeth of a comb in order to further improve the sensitivity of the sensor.

In addition, an oxide film may selectively be formed, instead of the formulation of the p⁺ polysilicon film 7.

Second Embodiment

Next, there will be made explanations about the production process of the second embodiment, emphasizing the points that are different from those in the first embodiment. In addition, in the second embodiment to be hereafter explained, explanations will be made by way of an example of a case where a sensor having a structure according to the structure illustrated in FIGS. 1 and 2, as explained in the

aforesaid first embodiment, and there will be illustrated a sectional view corresponding to the 2—2 section of FIG. 1.

In the aforesaid first embodiment, in order to form the cantilever 13, the p⁺ diffused layer (p⁺ polysilicon film) 7 is formed for the purpose of separating the cantilever portion from the single crystal silicon substrate at a predetermined distance, but in second present embodiment, a concave portion is formed before formation of a trench, for the purpose of separating the cantilever from the substrate at a predetermined distance.

In FIGS. 13 to 21, the production process is illustrated.

First, as illustrated in FIG. 13, an n type (100) single crystal silicon substrate 20 is provided, and on the main surface of the provided single crystal silicon substrate 20, there is formed a concave portion 21 with a predetermined depth e.g. ranging from 0.1 to 5 μm. Subsequently, as illustrated in FIG. 14, on the main surface of the single crystal silicon substrate 20, there is formed an SiO₂ film 22, and a pattern is formed by a photolithographic means, in the same way as in the aforesaid first embodiment. Subsequently, on the main surface of the single crystal silicon substrate 20 including the bottom of the concave portion 21, there is formed a trench with a depth ranging from about 0.1 to about 30 μm (3 μm in the present embodiment) by dry etching or the like.

Subsequently, as illustrated in FIG. 15, on the main surface of the single crystal silicon substrate 20 including the internal wall of the trench 23, there is formed an n⁺ diffused layer 24, and an SiO₂ film 25 is formed by thermal oxidation. Thereafter, as illustrated in FIG. 16, a polysilicon film 26 is deposited in the trench 23 by the LPCVD method.

Subsequently, as illustrated in FIG. 17, the surface of the polysilicon film 26 is polished by use of the SiO₂ film as an etching stopper, so as to smooth the surface. In the above case, although it is desirable that the surfaces of the polysilicon film 26 and the SiO₂ film 25 become smooth, even if the polysilicon film 26 is rather indented, so long as the surface of the SiO₂ film is made smooth, no inconvenience is caused in the subsequent wafer cementing.

On the other hand, as illustrated in FIG. 18, another (100) single crystal silicon substrate 27 is provided, and, on the main surface of the substrate 27, there is formed an SiO₂ film with a thickness ranging from 0.1 to 1.0 μm by thermal oxidation of the substrate. Subsequently, single crystal silicon substrates 20 and 27 are dipped in e.g. a solution of an aqueous hydrogen peroxide and sulfuric acid, so as to subject them to a hydrophilicity-imparting treatment. Subsequently, the substrates are dried, and thereafter, the main surfaces of the two single crystal silicon substrates 20 and 27 are put together at room temperature, and introduced into a furnace at 400 to 1100° C. for a period of time ranging from 0.5 and 2 hours, so as to strongly bond the two surfaces.

Subsequently, as illustrated in FIG. 19, the reverse side of the single crystal silicon substrate 20 is subjected to selective polishing by use of an aqueous solution of alkali type, e.g. an aqueous KOH solution. The selective polishing is performed until the SiO₂ film 25 appears on the surface. As a result, the thickness of the single crystal silicon substrate 20 becomes e.g. about 3 μm, so as to be made a thin film.

Subsequently, as illustrated in FIG. 20, a signal-processing circuit (IC circuit portion) 10 is formed through an ordinary CMOS process, bipolar process, or the like. Further, on the upper surface of the signal-processing circuit 10, there is formed, as a passivation film 11, a plasma SiN film (P-SiN film) by e.g. plasma CVD method.

Subsequently, windows **12** are opened at predetermined areas of the passivation film **11**, and the polysilicon film **20** is exposed to the surface at the sensor portion.

Subsequently, as illustrated in FIG. **21**, by use of a 20% solution of TMAH (tetramethylammonium hydroxide) $(\text{CH}_3)_4\text{NOH}$, the polysilicon film **26** is removed by etching from the reverse side of the single crystal silicon substrate **20** through the windows **12** on the passivation film **11**. In the above case, the passivation film **11** (P-SiN), SiO_2 film, and aluminum wiring layer are hardly etched by the selective etching.

As a result, a cantilever **13** is formed.

Also by the present embodiment, there is obtained the same effect as in the aforesaid first embodiment.

Third Embodiment

Next, there will be made explanations about the production process in the third embodiment, laying stress on the differential points between the first and third embodiments.

Although, in the aforesaid first and second embodiments, the trench is filled with polysilicon before the bonding of the wafers, in the present embodiment, the trench is filled with polysilicon after the bonding of wafers, and in the final stage, the thus filled polysilicon is removed, so as to produce an acceleration sensor.

In FIGS. **22** to **28**, the production process is illustrated.

First, as illustrated in FIG. **22**, an n-type (100) single crystal silicon substrate **30** is provided, and on the main surface of the provided single crystal silicon substrate **30**, there is formed a concave portion **31** in a depth ranging from 0.1 to 5 μm , in the same way as in the aforesaid second embodiment. On the other hand, as illustrated in FIG. **23**, a single crystal silicon substrate **32** is provided, and an SiO_2 film is formed by thermal oxidation on the main surface of the single crystal silicon substrate **31**. Thereafter, the main surface of the single crystal silicon substrate **30** is bonded to the main surface of a single crystal silicon substrate **32**.

Subsequently, as illustrated in FIG. **24**, the reverse side of the single crystal silicon substrate **30** is subjected to mirror polishing to a predetermined thickness (0.1 to 30 μm). Thereafter, as illustrated in FIG. **25**, there is formed an SiO_2 film **34** to a thickness ranging from 0.1 to 2 μm , following which the SiO_2 film is subjected to patterning, and a trench **35** is formed by etching. Thereby, a cantilever **13** and a transversal insulatedly separated area of the processing circuit portion are formed.

Next, by thermal diffusion or the like, there is introduced an N type impurity of arsenic or phosphorus in a high concentration, and a highly concentrated n^+ layer **36** is formed in the silicon area which is not covered with SiO_2 films **33** and **34**.

Subsequently, as illustrated in FIG. **26**, a thermal oxidation film is formed on the side wall of the trench **35** and the like, whereafter a polysilicon film **37** is formed on the surface of the single crystal silicon substrate **30**, and the trench **35** is filled with the polysilicon film **37**. Thereafter, as illustrated in FIG. **27**, the surface of the polysilicon film **37** is selectively polished and smoothed until the SiO_2 film **34** appears on the surface. Further, as illustrated in FIG. **28**, a signal-processing circuit **10** is formed, and finally, the polysilicon film **37** is removed by etching from the reverse side (upper surface side) of the single crystal silicon substrate **30**, so as to again separate the cantilever **13** from the substrate to allow it to move.

As described above, in the present third embodiment, the main surface of the single crystal silicon substrate **30** is

bonded to the single crystal silicon substrate **32** with the SiO_2 film (insulating film) **33** formed thereon, through said SiO_2 film **33** being interposed between the substrate **30** and **32** (first step), and the reverse side of the single crystal silicon substrate is polished to a predetermined degree, so as to make the single crystal silicon substrate **30** a thin film (second step). Subsequently, on the reverse side of the single crystal silicon substrate **30**, there is formed a trench (groove) **35** with a predetermined depth for formation of a cantilever **13** (third step), and the trench **35** is filled with the polysilicon film **37**, and the surface of the polysilicon film **37** is smoothed (fourth step). Subsequently, a signal-processing circuit is formed on the single crystal silicon substrate **30**, whereafter the polysilicon film **37** is removed, by etching, from the reverse side of the single crystal silicon substrate **30**, so as to form a cantilever **13** (fifth step).

Therefore, in the process of formation of the signal-processing circuit **10** in the wafer, the trench **35** is filled with the polysilicon film **37** in the upper surface part of the single crystal silicon substrate **30**, whereby contamination of the IC elements, contamination of the production apparatus, and degradation or deterioration of electrical properties attended therewith can be prevented. That is, by contriving not to make a surface structure such as a concave portion or a perforation of the like appear on the wafer surface in the heat treatment, the photolithographical treatment or the like in the course of the wafer process, contamination and the like can be prevented, so as to stabilize the wafer process, and a stable supply of acceleration sensors, of high precision, can be produced.

Fourth Embodiment

In the following, there will be made explanations about the production process of the fourth embodiment, laying stress on the differences between the present embodiment and the third embodiment.

The present embodiment is intended to produce an acceleration sensor at a lower cost than the production process of the third embodiment.

In FIGS. **29** to **31**, the production process is illustrated.

First, as illustrated in FIG. **29**, an SiO_2 film with a thickness ranging from 0.1 to 2 μm is formed on the main surface of a single crystal silicon substrate **40**, and a single crystal silicon substrate **42** is bonded to the substrate **40** so as to interpose the SiO_2 film **41** between the substrates **40** and **42**. Subsequently, as illustrated in FIG. **30**, the upper surface of the single crystal silicon substrate **42** is polished so as to make the thickness of the single crystal silicon substrate a predetermined value. That is, the thickness of the single crystal silicon substrate **42** is reduced to e.g. about 3 μm . Thereafter, a highly concentrated n^+ diffused layer **43** is formed on the upper surface of the single crystal silicon substrate **42**, and further, an SiO_2 film **44** is formed thereon. It suffices if this highly concentrated n^+ diffused layer **43** is formed corresponding to the parts of the sensor which will be formed as movable electrodes and fixed electrodes.

Subsequently, as illustrated in FIG. **31**, patterning is applied to an SiO_2 film, as in the third embodiment, and a trench **45** is formed on the single crystal silicon substrate **42**. Thereafter, the SiO_2 film **41** below this trench **45** is partly removed by etching with an aqueous hydrofluoric acid solution. In this case, a part of SiO_2 film **41**, below the part to be formed as a cantilever **13**, is completely removed, and another part of the SiO_2 film **41**, below the part to be formed as solid electrodes and signal-processing circuit portion, is left. Because the lower portion of the part is to be formed as the cantilever **13** it is narrower than with the other part. In

11

addition, in the above case, the highly concentrated n⁺ diffused layer 43 is separated into the cantilever 13 and fixed electrodes.

Subsequently, through the same processes as illustrated in FIGS. 26 to 28, there is produced a capacity type acceleration sensor.

In the following, there will be explained application examples of the fourth embodiment with reference to FIGS. 32 to 34.

First, as illustrated in FIG. 32, an SiO₂ film with a thickness ranging from 0.1 to 2 μm is formed on the main surface of the single crystal silicon substrate 40, and a concave portion 47 with a depth ranging from 0.1 to 3 μm is formed at the area of the main surface of the single crystal silicon substrate 42, on which area a cantilever is to be formed. Subsequently, the main surface of the single crystal silicon substrate 42 is bonded to the main surface of the single crystal silicon substrate 40, the SiO₂ film 41 being put therebetween. Further, as illustrated in FIG. 33, the upper surface of the single crystal silicon substrate 42 is polished so as to give the single crystal silicon substrate 42 a predetermined thickness. That is, the thickness of the single crystal silicon substrate 42 is made thin to a value of about 3 μm. Subsequently, the aforesaid highly concentrated diffused layer 43 is formed on the upper surface of the single crystal silicon substrate 42, and an SiO₂ film 44 is formed thereon.

Subsequently, as illustrated in FIG. 34, onto the single crystal silicon substrate 42, there are formed trenches 45 extending to the concave portions 47, and cantilevers 13 are formed.

Thereafter, a capacity type acceleration sensor is produced through the same processes as illustrated in FIGS. 26 to 28.

By conducting the aforesaid procedures, electrical insulation can be made more securely as compared with the case where the SiO₂ film 41 is partly removed by etching. In addition, the mechanical strength of the sensor can be improved.

In addition, the present invention is not restricted to the aforesaid embodiments, and is applicable to a twin-lever spring or a polyever spring embodiment, in addition to a cantilever spring embodiment.

In addition, as illustrated in FIG. 35, it is possible to form two acceleration sensors 13a and 13b onto a single crystal silicon substrate 50, for detecting the acceleration in the direction X by the acceleration sensor 13a, and the acceleration in the direction Y by the acceleration sensor 13b. Further, it is possible to form an acceleration sensor capable of detecting the acceleration in a direction surface perpendicular to these X and Y direction acceleration sensors 13a and 13b, on the same substrate, so as to detect an acceleration in three-dimensionals. In addition, when the present acceleration sensor is used as a capacity type acceleration sensor, it is possible to further stabilize the properties by forming the present acceleration sensor into a so-called "servo type" sensor (with a closed-loop circuit).

In addition, in the aforesaid embodiments, the trenches (grooves) 3, 23, and 35 are filled with polysilicon films 6, 26, and 37, respectively, but there may be used a film of polysilicon, amorphous silicon or a mixed silicon containing polysilicon and amorphous silicon.

In addition, in the aforesaid embodiments, a sensor portion and a signal-processing portion are formed in the single crystal silicon substrate to be formed as the upper side, but

12

the present acceleration sensor is not restricted to such a structure, and it is possible to utilize also a single crystal silicon substrate formed as a base, and form a sensor portion and a signal-processing portion on the lower substrate.

As described in detail in the foregoing, according to the present invention, high precision and high reliability can be realized by formatting a novel structure. In addition, when a signal-processing circuit is provided on the same chip as a movable beam, since there is produced neither a hollow part nor a groove during the production process, it is possible to make the processing stable. In addition, it is at the final step that the movable beam is made movable with respect to the substrate, whereby, in the case of the movable beam being bonded to the lower substrate to be formed as a pedestal or in the case of a circuit being formed, or the like, minute beams can be prevented from being broken, and the yield thereof can be made higher. In addition, since it is a micro-machining technique which determines the shape of the present acceleration sensor, the present acceleration sensor can be produced with high precision.

[Industrial Availability]

As described in the foregoing, the present invention is useful for the production of a semi-conductor acceleration sensor having minute movable parts, and the present acceleration sensor is suitable as an acceleration sensor to be used for air bag system, suspension control system and the like of automobiles. In addition, the present invention can be applied to a capacity type acceleration sensor for detecting acceleration in multiple directions.

I claim:

1. An acceleration sensor comprising:

a first substrate formed of a silicon material which is used as a conductive material;

a second substrate provided on the lower side of said first substrate and electrically insulated from the first substrate;

said first substrate including:

a support beam having a mass portion forming capacitive electrodes for displacement in a parallel direction to a surface of said second substrate according to the degree of acceleration, a fixed portion for fixing said support beam to said second substrate and a support portion for intermediately supporting said mass portion to said fixed portion,

an insulating groove extending through a thickness of said first substrate around the entire periphery of said support beam, and stationary blocks forming capacitive electrodes defined by said insulating groove on the outer sides of said support beam separately across said insulating groove and fixed to said second substrate; and

gap means forming a gap space in order to space said mass portion and said supporting portion from a surface of said second substrate; and

said second substrate being separated from said first substrate by an insulating layer which is at least provided on the lower side of said fixed portion and stationary blocks.

2. An acceleration sensor as defined in claim 1, wherein said insulating groove defines a narrow detection groove between said mass portion of said support beam and each of said stationary blocks, and movable and stationary electrodes are formed on lateral side surfaces of said support beam and said stationary blocks in face to face relation with each other across said detection groove.

3. An acceleration sensor as defined in claim 1, wherein said support beam is securely fixed to said second substrate

13

at said fixed end, and reduced in a width in said support portion to provide at least one support for said mass portion in a fore free end portion to be displayed horizontally according to the degree of acceleration in the fashion of at least one fulcrum point type acceleration sensor.

4. An acceleration sensor as defined in claim 3, wherein said width of said support portion is smaller than a thickness of said fixed portion and said support beam provides a cantilever type support.

5. An acceleration sensor as defined in claim 1, wherein said first substrate is formed of silicon material with a (100) crystal face.

6. An acceleration sensor as defined in claim 5, wherein said first substrate is formed of a n-type silicon material.

7. An acceleration sensor as defined in claim 1, wherein said second substrate is formed of a silicon material having a surface covered with an insulating oxidation film.

8. An acceleration sensor comprising:

a substrate which is selected from the group consisting of an insulating material and oxidized semiconductor material;

a support beam which includes a mass portion forming a predetermined mass and first capacitive electrodes on side surfaces of said mass portion, a fixed portion for fixing said support beam to said substrate and thin support portion for intermediately connecting between said mass portion and said fixed portion;

a pair of stationary blocks arranged on both sides of said support beam separately across an air gap and fixed to said substrate, said stationary blocks provided with second capacitive electrodes on the opposite sides of first capacitive electrodes of said mass portion;

gap means forming a gap space in order to space said mass portion and thin support portion from a surface of said substrate; and

said mass portion being displace in a parallel direction to the surface of said substrate according to the degree of acceleration and said support beam and stationary blocks formed of a silicon material which is used as a conductive material and electrically insulated from said substrate.

9. An acceleration sensor as defined in claim 8, wherein said gap means is formed of an insulating layer at least between said substrate and said fixed portion of the support beam and said stationary blocks.

10. An acceleration sensor as defined in claim 8, wherein movable and stationary electrodes are formed on lateral side surfaces of said mass portion and said stationary blocks in face to face relation with each other across air gap.

11. An acceleration sensor as defined in claim 8, wherein a width of said thin support portion is smaller than a thickness of said fixed portion.

12. An acceleration sensor as defined in claim 8, wherein said support beam and stationary blocks are formed of a n-type silicon material with a (100) crystal face.

13. An acceleration sensor as defined in claim 8, wherein said substrate is formed of a silicon material having a surface covered with an insulating oxidation film.

14. An acceleration sensor comprising:

A. a first single crystalline silicon substrate having a first surface and a second surface opposite said first surface;

B. a second single crystalline silicon substrate connected to a side of said first surface of said first single crystalline silicon substrate with an insulating layer interposed therebetween;

14

C. said first single crystalline silicon substrate including:

i. a movable beam defined by a trench which is disposed to surround said movable beam and extend from said second surface to said first surface, said movable beam being supported by said second single crystalline silicon substrate through said insulating layer to be displaceable in a direction parallel to said first surface of said first single crystalline silicon substrate,

ii. a stationary block disposed to be spaced apart from said movable beam via said trench, facing said movable beam to form a pair of capacitive electrodes with said movable beam, and fixed to said second single crystalline silicon substrate; and

D. a signal-processing circuit element for carrying out a processing operation based on a change of a capacitance between said capacitive electrodes.

15. An acceleration sensor as defined in claim 14, wherein said movable beam has a first thickness along said direction parallel to said first surface of said first single crystal silicon substrate and a second thickness in a direction perpendicular to said first surface of said first crystal silicon substrate, said first thickness being smaller than said second thickness.

16. An acceleration sensor as defined in claim 14, wherein at least one of a surface of said movable beam exposed to said trench and a surface of said first single crystal silicon substrate facing and movable beam is covered with an insulator.

17. An acceleration sensor as defined in claim 14, wherein said movable beam or said stationary block comprise an impurity-doped region to form said capacitive electrodes.

18. An acceleration sensor as defined in claim 14, further comprising first, second and third stationary blocks, each of which is formed of a part of said first single crystal silicon substrate, and wherein said movable beam includes a first branch and a second branch, said first branch being interposed between said stationary block and said first stationary block with a first air gap defined therebetween, said second branch of said movable beam being interposed between said second and said third stationary blocks with a second air gap defined therebetween, said stationary block and said second stationary block being electrically connected with each other, said first and said third stationary blocks being electrically connected with each other.

19. An acceleration sensor according to claim 14, wherein said signal-processing circuit is disposed on said first single crystal silicon substrate.

20. An acceleration sensor comprising:

A. a first single crystalline silicon substrate having a first surface and a second surface opposite said first surface;

B. a second single crystalline silicon substrate connected to a side of said first surface of said first single crystalline silicon substrate with an insulating layer interposed therebetween;

C. said first single crystalline silicon substrate being divided by a trench extending from said second surface to said first surface;

i. a movable beam portion surrounded by said trench, said movable beam portion being supported by said second single crystalline silicon substrate through said insulating layer to be displaceable in a direction parallel to said first surface of said first single crystalline silicon substrate, said movable beam portion having a movable electrode,

ii. a stationary portion disposed to be spaced apart from said movable beam via said trench, having a stationary electrode which faces said movable beam via

15

said trench to form a pair of capacitive electrodes with said movable electrode, and fixed to said second single crystalline silicon substrate; and

D. an insulator covering at least one of a surface of said movable electrode and a surface of said stationary electrode.

21. An acceleration sensor as defined in claim 20, further comprising a signal-processing circuit defined in the first single crystal silicon substrate for carrying out a processing operation based on a change of a capacitance between said movable electrode and said stationary electrode.

22. *A semiconductor capacitor-type sensor comprising: a first layer formed of a silicon material which is used as a conductive material, a second layer provided under said first layer;*

said first layer including:

a support beam having a mass portion forming capacitive electrodes for displacement in a substantially parallel direction to a surface of said second layer according to the degree of mechanical force, a fixed portion for fixing said support beam to said second layer and a support portion for intermediately supporting said mass portion to said fixed portion;

an insulating groove extending through a thickness of said first layer around said support beam;

a stationary block forming capacitive electrodes defined by said insulating groove and fixed to said second layer; and

wiring layers formed on said stationary block and said support beam; wherein

said second layer is separated from said first layer by an insulating layer; and

said wiring layers have an air bridge structure over said insulating groove.

23. *The sensor according to claim 22, wherein said insulating layer is provided on the lower side of said fixed portion.*

24. *A semiconductor capacitance-type sensor as defined in claim 22, wherein said insulating groove defines a narrow detection groove between said mass portion of said support beam and said stationary block, and movable and stationary electrodes are formed on lateral side surfaces of said support beam and said stationary block in face to face relation with each other across said detection groove.*

25. *A semiconductor capacitance-type sensor as defined in claim 22, wherein said support beam is securely fixed to said second layer at a fixed end, and reduced in a width in said support portion to provide at least one support for said mass portion in a fore free end portion to be displayed horizontally according to the degree of mechanical force in the fashion of at least one fulcrum point type mechanical sensor.*

26. *A semiconductor capacitance-type sensor as defined in claim 25, wherein said width of said support portion is smaller than a thickness of said support beam.*

16

27. *A semiconductor capacitance-type sensor as defined in claim 22, wherein said first layer is formed of silicon material with a (100) crystal face.*

28. *A semiconductor capacitance-type sensor as defined in claim 27, wherein said first layer is formed of a n-type silicon material.*

29. *A semiconductor capacitance-type sensor as defined in claim 22, wherein said second layer is formed of a silicon material having a surface covered with an insulating oxidation film.*

30. *Semiconductor capacitance-type sensor according to claim 22, wherein said support beam has a first thickness along said direction parallel to a surface of said first layer and a second thickness in a directional perpendicular to said surface of said first layer, said first thickness being smaller than said second thickness.*

31. *An acceleration sensor according to claim 22, wherein said support beam or said stationary block comprise an impurity-doped region to form said capacitive electrodes.*

32. *An acceleration sensor according to claim 22, wherein said stationary block includes first, second, third and fourth blocks, each of which is formed of a part of said first layer, and said support beam includes a first branch and a second branch, said first branch being interposed between said first block and said second block with a first air gap defined therebetween, said second branch being interposed between said third block and said fourth block with a second air gap defined therebetween, said first block and said third block being electrically connected with each other, said second block and said fourth block being electrically connected with each other.*

33. *A semiconductor capacitor-type sensor comprising: a first layer formed of a silicon material which is used as a conductive material, a second layer provided under said first layer;*

said first layer including:

a support beam having a mass portion forming capacitive electrodes for displacement in a substantially parallel direction to a surface of said second layer according to the degree of mechanical force, a fixed portion for fixing said support beam to said second layer and a support portion for intermediately supporting said mass portion to said fixed portion;

an insulating groove extending through a thickness of said first layer around said support beam;

a stationary block forming capacitive electrodes defined by said insulating groove and fixed to said second layer; and

wiring layers formed from said stationary block and said support beam; wherein

said second layer being separated from said first layer by an insulating layer; and

said wiring layers have an air bridge structure over said insulating groove.

* * * * *

UNITED STATES PATENT AND TRADEMARK OFFICE
CERTIFICATE OF CORRECTION

PATENT NO. : RE 40,347 E
APPLICATION NO. : 10/123220
DATED : June 3, 2008
INVENTOR(S) : Tetsuo Fujii

Page 1 of 1

It is certified that error appears in the above-identified patent and that said Letters Patent is hereby corrected as shown below:

Col. 13, line 38, claim 8, "displace" should be --displaced--

Col. 13, line 51, claim 10, after "across" insert --said--

Col. 14, line 27, claim 16, "and" should be --said--

Col. 16, line 13, claim 30, "directional" should be --direction--

Col. 16, line 49, claim 33, "formed" should --extending--

Signed and Sealed this

Second Day of June, 2009



JOHN DOLL
Acting Director of the United States Patent and Trademark Office