

US00RE40314E

(19) **United States**
(12) **Reissued Patent**
Rock et al.

(10) **Patent Number: US RE40,314 E**
(45) **Date of Reissued Patent: May 13, 2008**

(54) **VELOUR FABRIC ARTICLES HAVING FLAME RETARDANCE AND IMPROVED DYNAMIC INSULATION PERFORMANCE**

(75) Inventors: **Moshe Rock**, Brookline, MA (US); **Edward P. Dionne**, South Paris, ME (US); **Charles Haryslak**, Marlborough, MA (US); **William K. Lie**, Methuen, MA (US); **Douglas Lumb**, Atkinson, NH (US); **Jane Hunter**, Manassas, VA (US)

(73) Assignee: **MMI-IPCO, LLC**, Lawrence, MA (US)

(21) Appl. No.: **11/635,820**

(22) Filed: **Dec. 7, 2006**

Related U.S. Patent Documents

Reissue of:

(64) Patent No.: **6,828,003**
Issued: **Dec. 7, 2004**
Appl. No.: **10/122,024**
Filed: **Apr. 12, 2002**

U.S. Applications:

(60) Continuation-in-part of application No. 09/982,720, filed on Oct. 18, 2001, which is a continuation-in-part of application No. 09/883,643, filed on Jun. 18, 2001, now abandoned, which is a division of application No. 09/347,825, filed on Jul. 2, 1999, now abandoned.

(51) **Int. Cl.**
B32B 33/00 (2006.01)
B27N 9/00 (2006.01)
D04B 1/14 (2006.01)
D04B 1/16 (2006.01)

(52) **U.S. Cl.** **428/97**; 428/91; 428/93; 428/95; 428/920; 428/921; 442/136; 442/306; 442/312

(58) **Field of Classification Search** 428/91, 428/93, 95-97, 920, 921; 442/136, 306, 308, 442/311, 312

See application file for complete search history.

(56) **References Cited**

U.S. PATENT DOCUMENTS

3,837,943 A * 9/1974 Ploch et al. 156/93
4,067,209 A * 1/1978 Kucera et al. 66/193

(Continued)

FOREIGN PATENT DOCUMENTS

EP 0 111 409 * 6/1984
EP 0111409 A1 * 6/1984

(Continued)

OTHER PUBLICATIONS

Adanur, Sabit Ph.D. Wellington Handbook of Industrial Textiles, Technomic Publishing Co., Inc. 1995. pp. 176-177, 597-599.*

FR 274133 A1 English Abstract Oct. 10, 1997.*

(Continued)

Primary Examiner—Jenna Befumo

(74) *Attorney, Agent, or Firm*—Fish & Richardson P.C.

(57) **ABSTRACT**

A velour fabric article consists of a fabric body having a technical face formed by a filament stitch yarn and a technical back formed by a loop yarn. The filament stitch yarn includes a heat sensitive material, e.g. a hot melt material or a heat shrinkable material, and/or an elastomeric material, such as spandex. The loop yarn includes flame retardant material, such as M-Aramide fiber. The fabric body has a velour surface formed at one or both of the technical back and the technical face. Raised fibers of at least one of the technical face and the technical back may be entangled, including in and/or through interstices of the fabric body, toward the other of the technical face and the technical back, e.g., by a hydroentanglement process applied after finishing. The fabric body has permeability of about 90 ft³/ft²/min, or less, under a pressure difference of ½ inch of water across the fabric body.

36 Claims, 6 Drawing Sheets

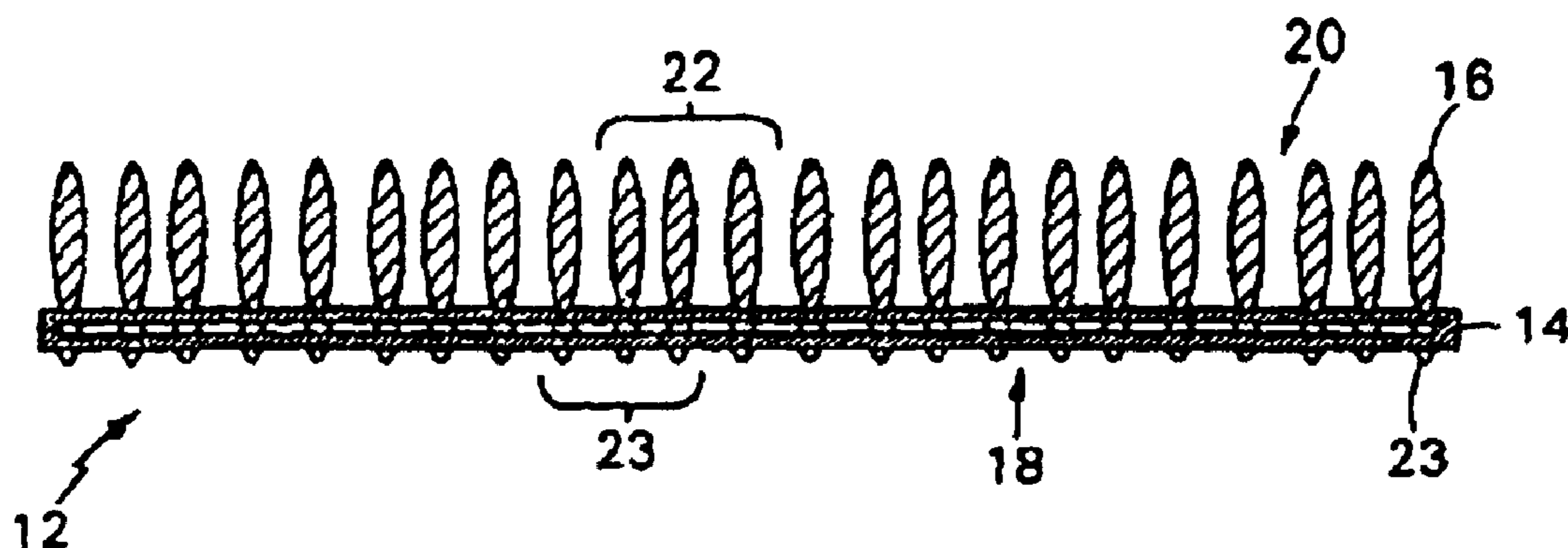

US RE40,314 E

Page 2

U.S. PATENT DOCUMENTS

4,103,518 A * 8/1978 Lombardi et al. 66/107
4,546,026 A * 10/1985 Kowalski 428/91
5,520,022 A * 5/1996 Callaway 66/194
5,557,950 A * 9/1996 Richards et al. 66/194
5,598,615 A * 2/1997 Takada 28/159
5,727,401 A 3/1998 Statham
6,082,147 A * 7/2000 Rock et al. 66/191
6,164,095 A * 12/2000 Rock et al. 66/194
2002/0124365 A1 * 9/2002 Wood et al. 26/2 R
2004/0132367 A1 7/2004 Rock

FOREIGN PATENT DOCUMENTS

EP 0313261 4/1989
EP 0445395 9/1991
EP 0541206 5/1993
EP 1067226 A2 * 1/2001
FR 2 313 486 * 12/1976
FR 2313486 A * 2/1977
FR 2512081 A1 * 3/1982
FR 2 512 081 * 3/1983
FR 2747133 A1 * 10/1997
FR 2 747 133 * 10/1997
GB 2106153 A * 4/1983
GB 2 106 153 * 7/1983

WO WO 00 44969 * 8/2000
WO WO 200044969 A1 * 8/2000

OTHER PUBLICATIONS

European Search Report; EP 02 25 7260; D. Sterle; Jan. 15, 2003.*

Patent Abstracts of Japan; vol. 015, No. 173 (C-0828); May 2, 1991 & JP 03 040845 A; Feb. 21, 1991.*

Patent Abstracts of Japan; vol. 1995, No. 11, Dec. 26, 1995 & JP 07 197354 A; Aug. 1, 1995.*

International Search Report; EP 03 25 2366; Sep. 2003; P. Van Gelder.*

Patent Abstracts of Japan; vol. 1998, No. 3, Feb. 27, 1998; JP 09 302560; Nov. 25, 1997.*

Canadian Journal of Research; OL. 25, Sec. A; July, 1974; No. 4; "The Effect of Wing on the Thermal Resistance of Clothing . . . Various Permeabilities"; P. Larose; pp. 169-190.*

"Standard Test Method for Permeability of textile Fabrics"; ASTM Designation: D737-96; pp. 230-234.*

European Search Report.

* cited by examiner

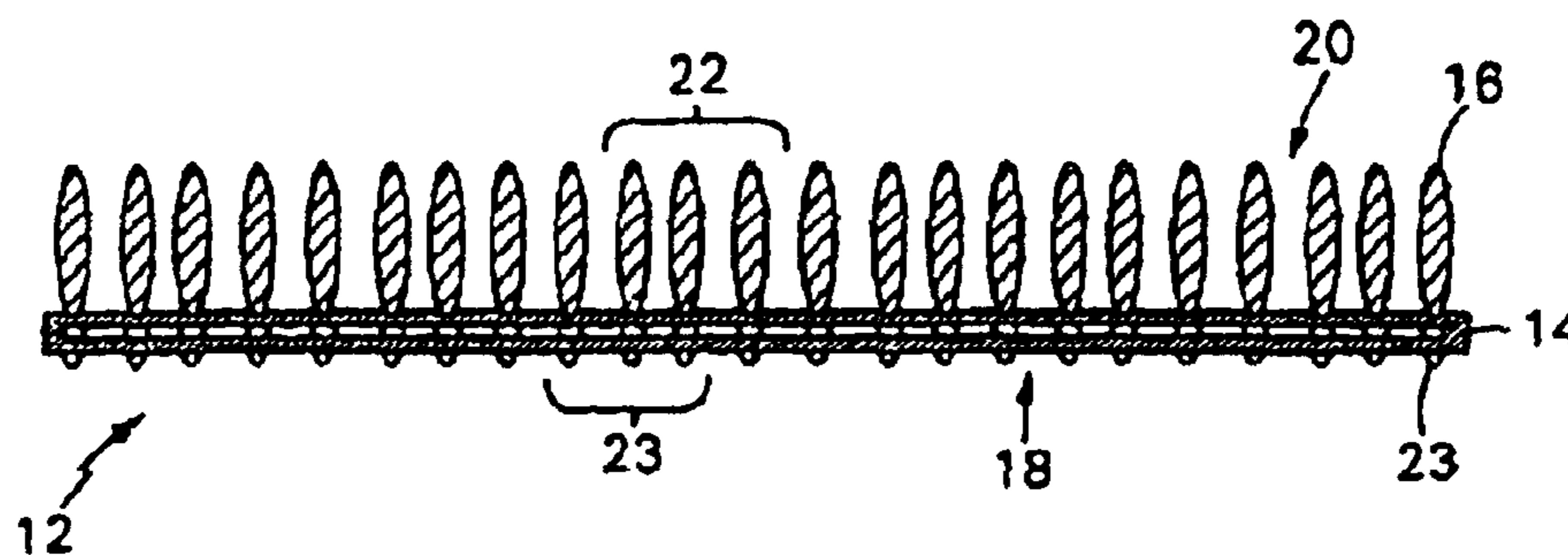

FIG. 1

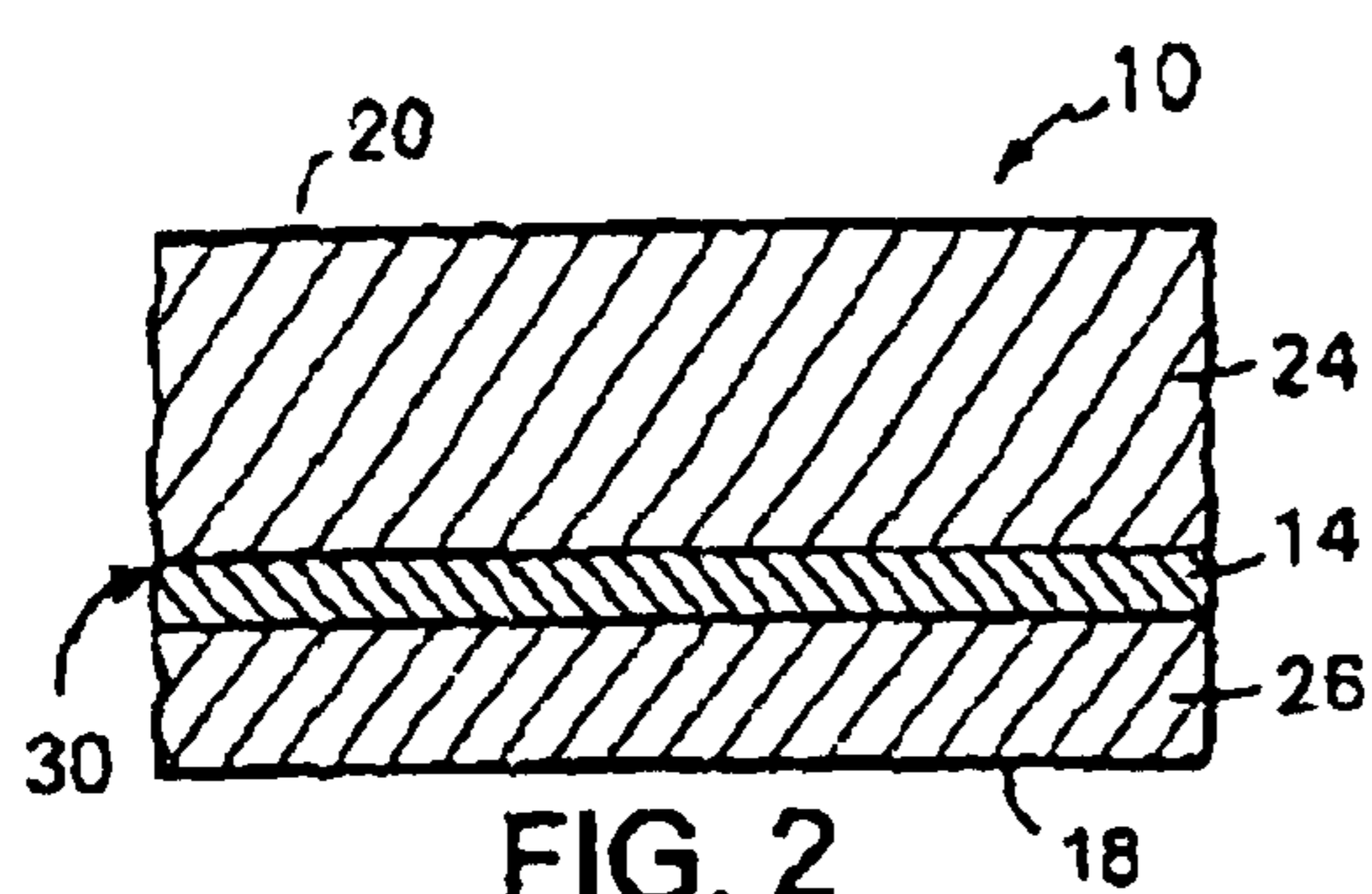
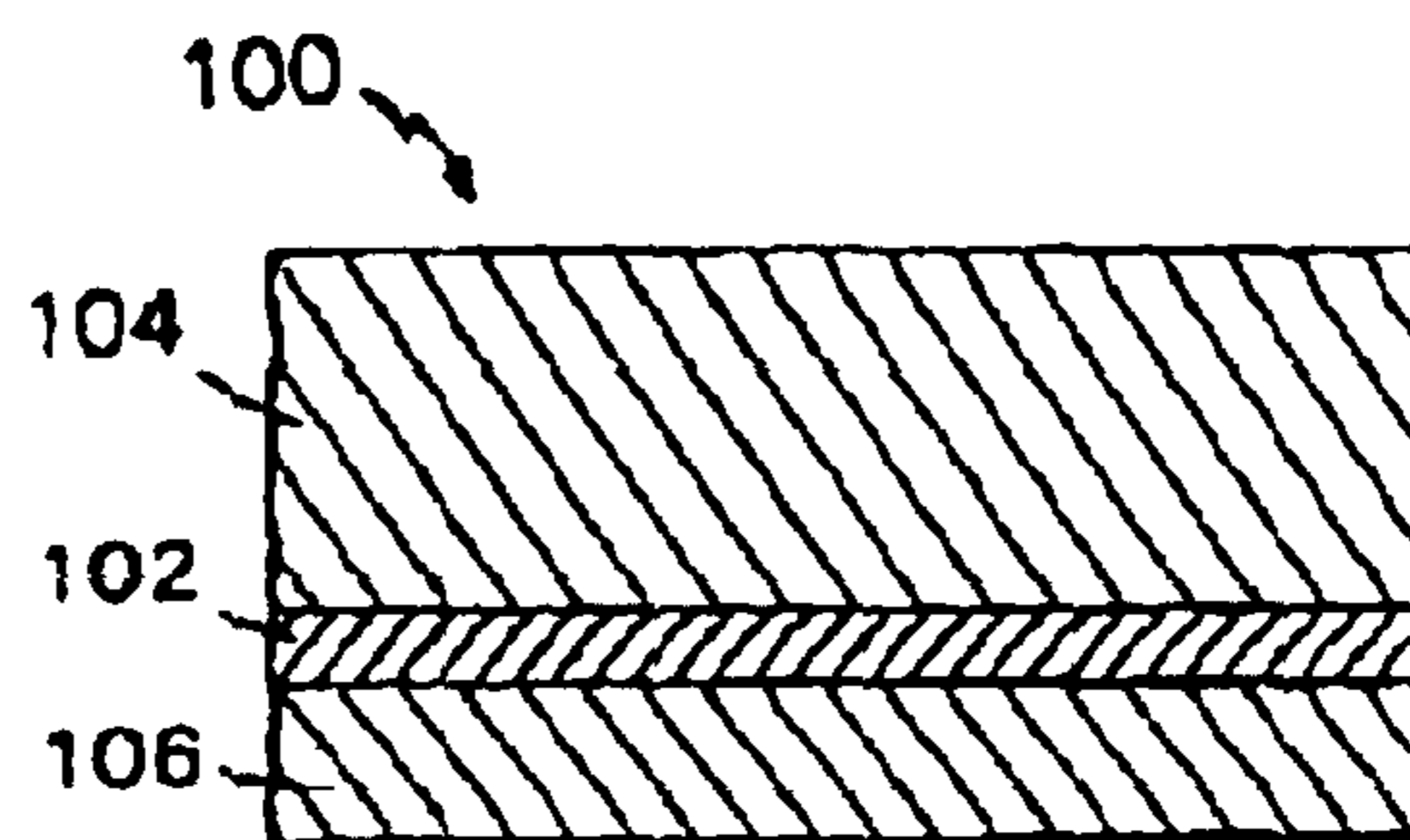

FIG. 2



PRIOR ART
FIG. 3

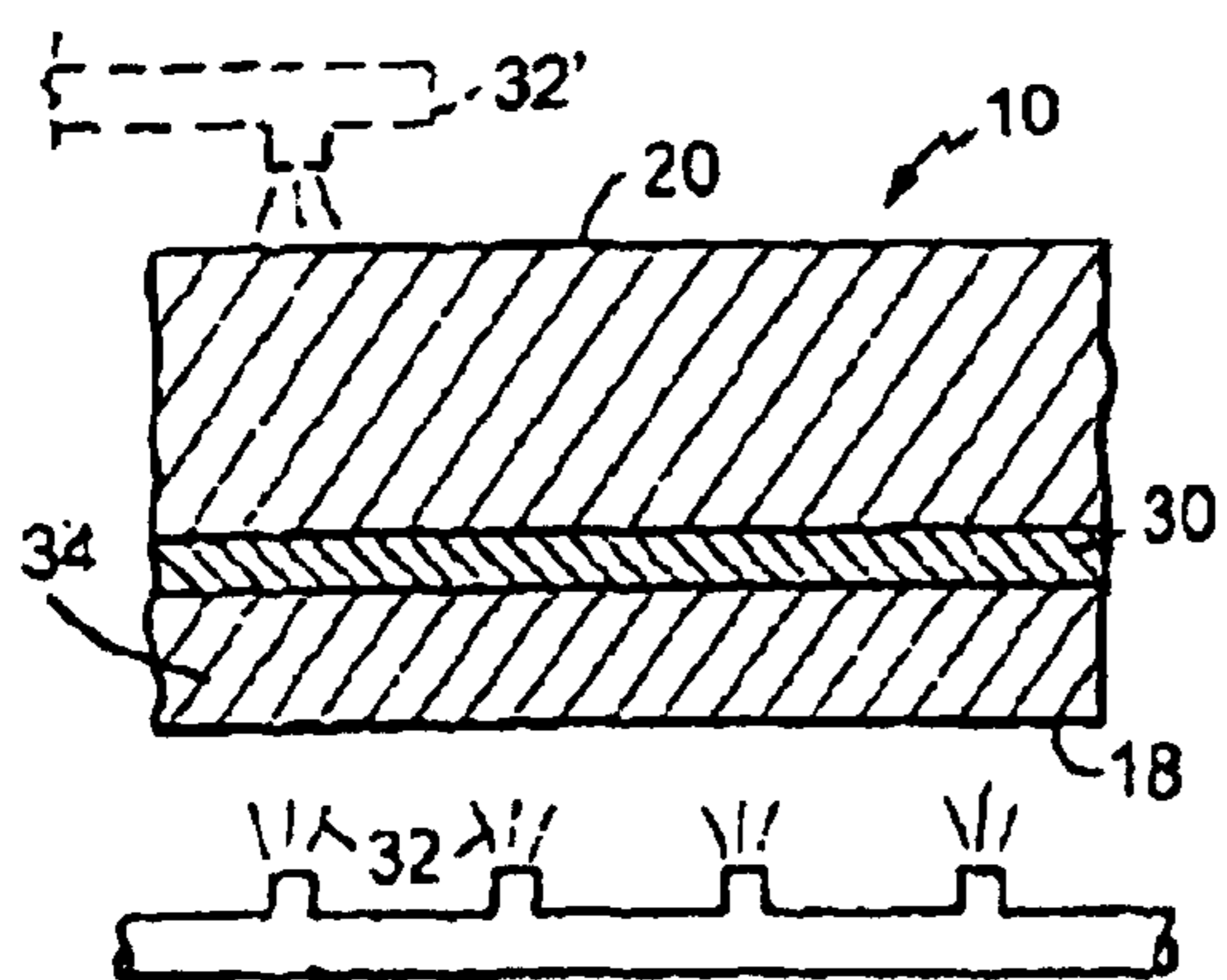

FIG. 12

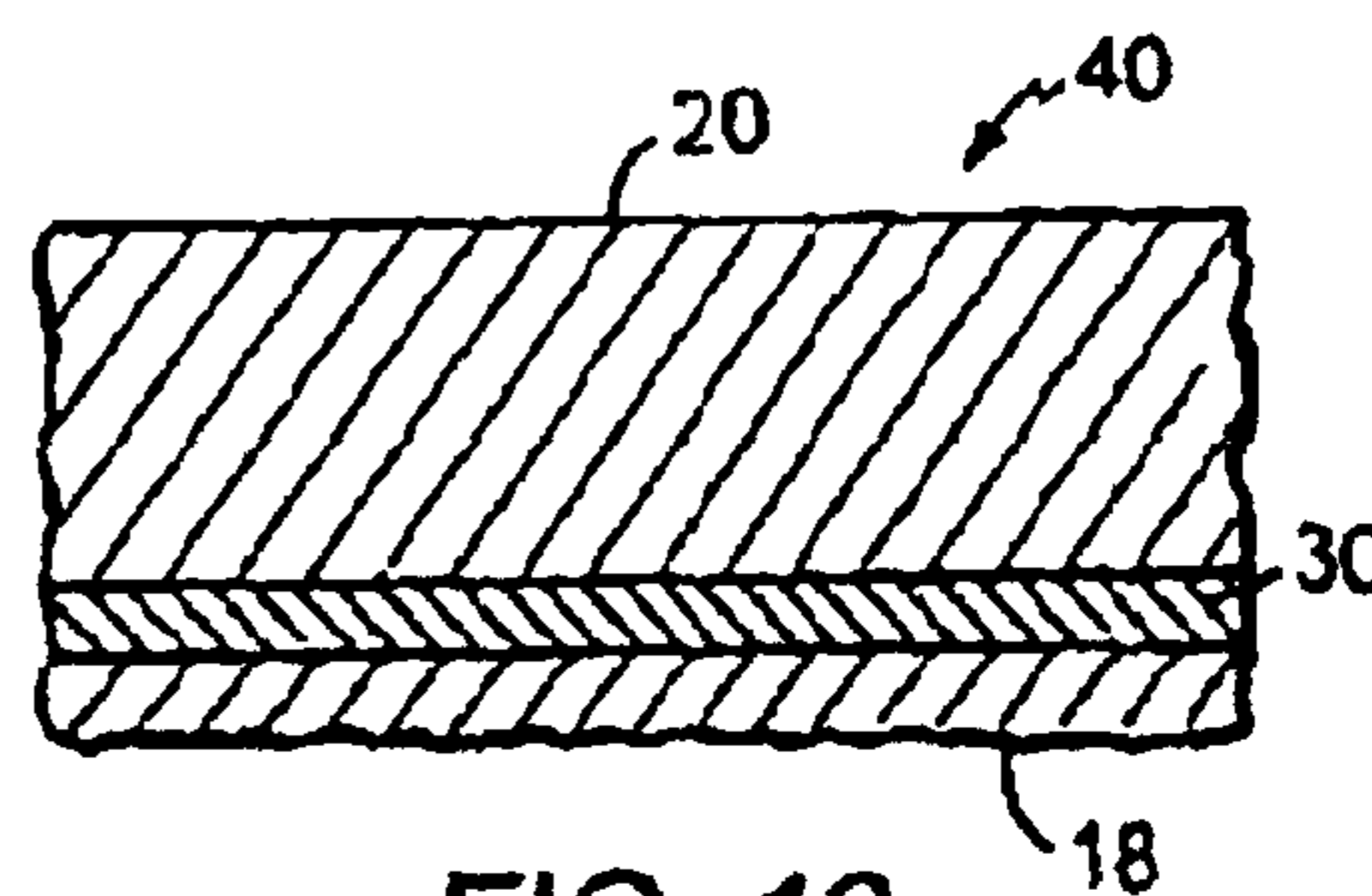

FIG. 13

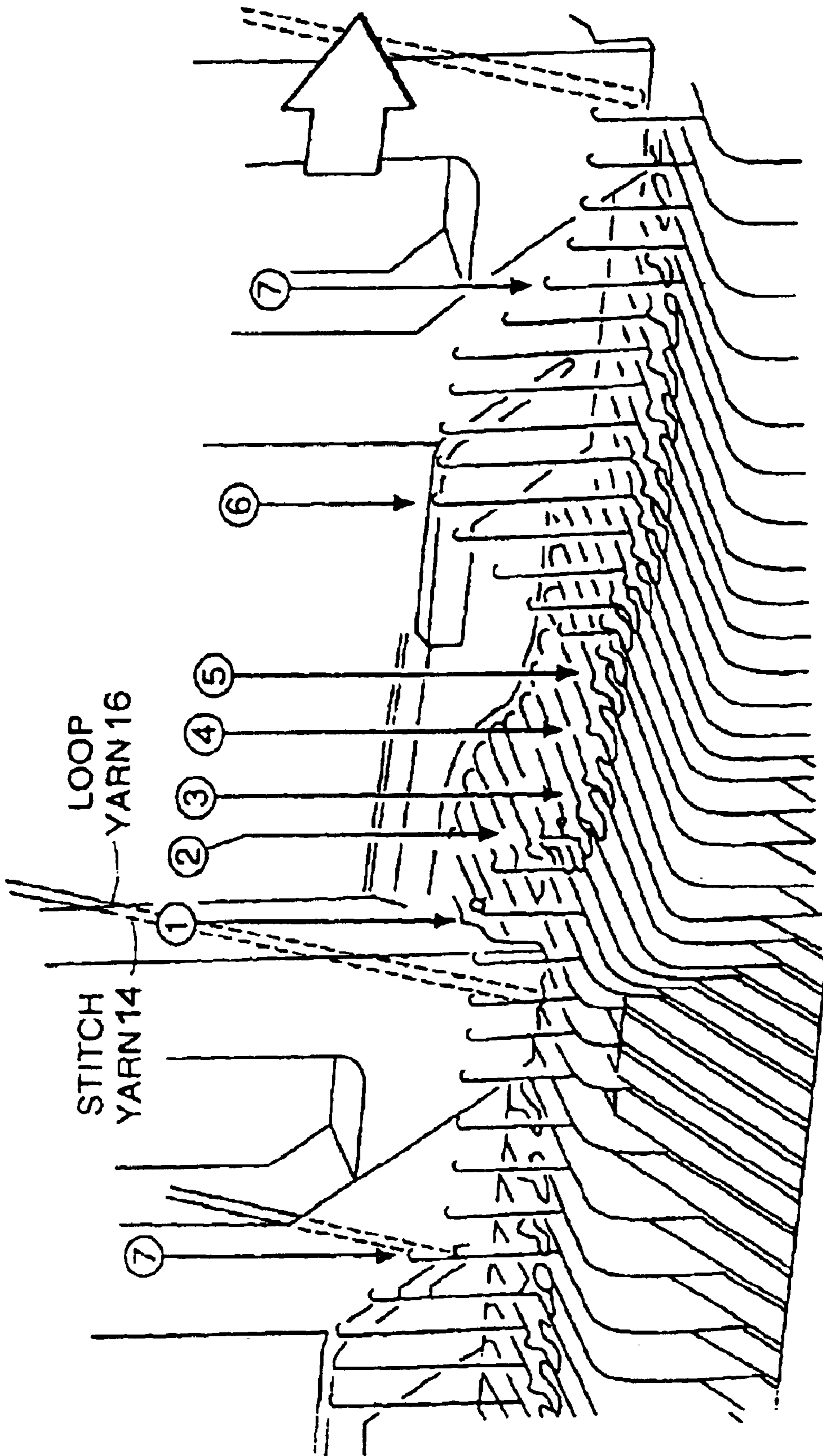

FIG. 4

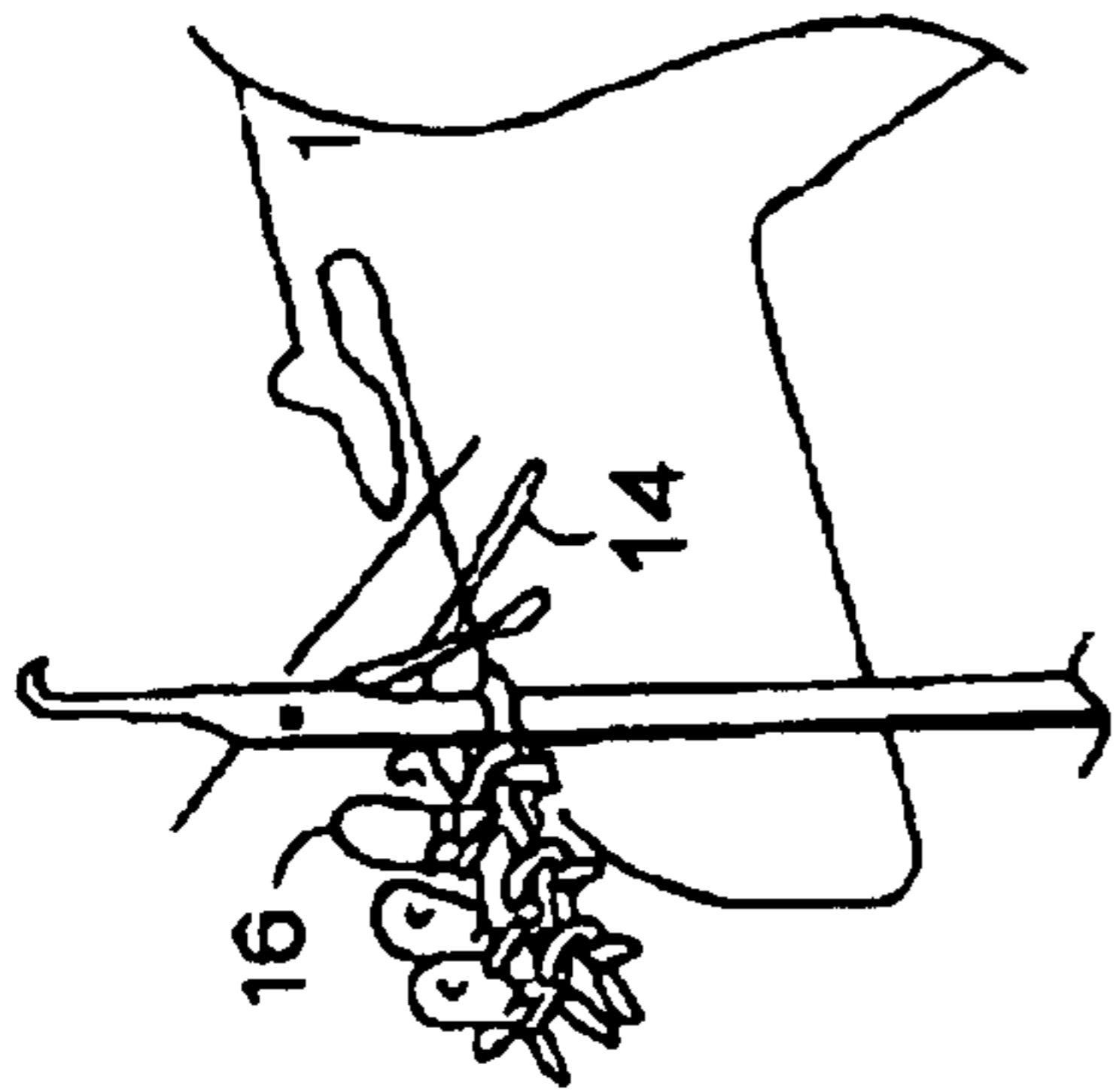

FIG. 5

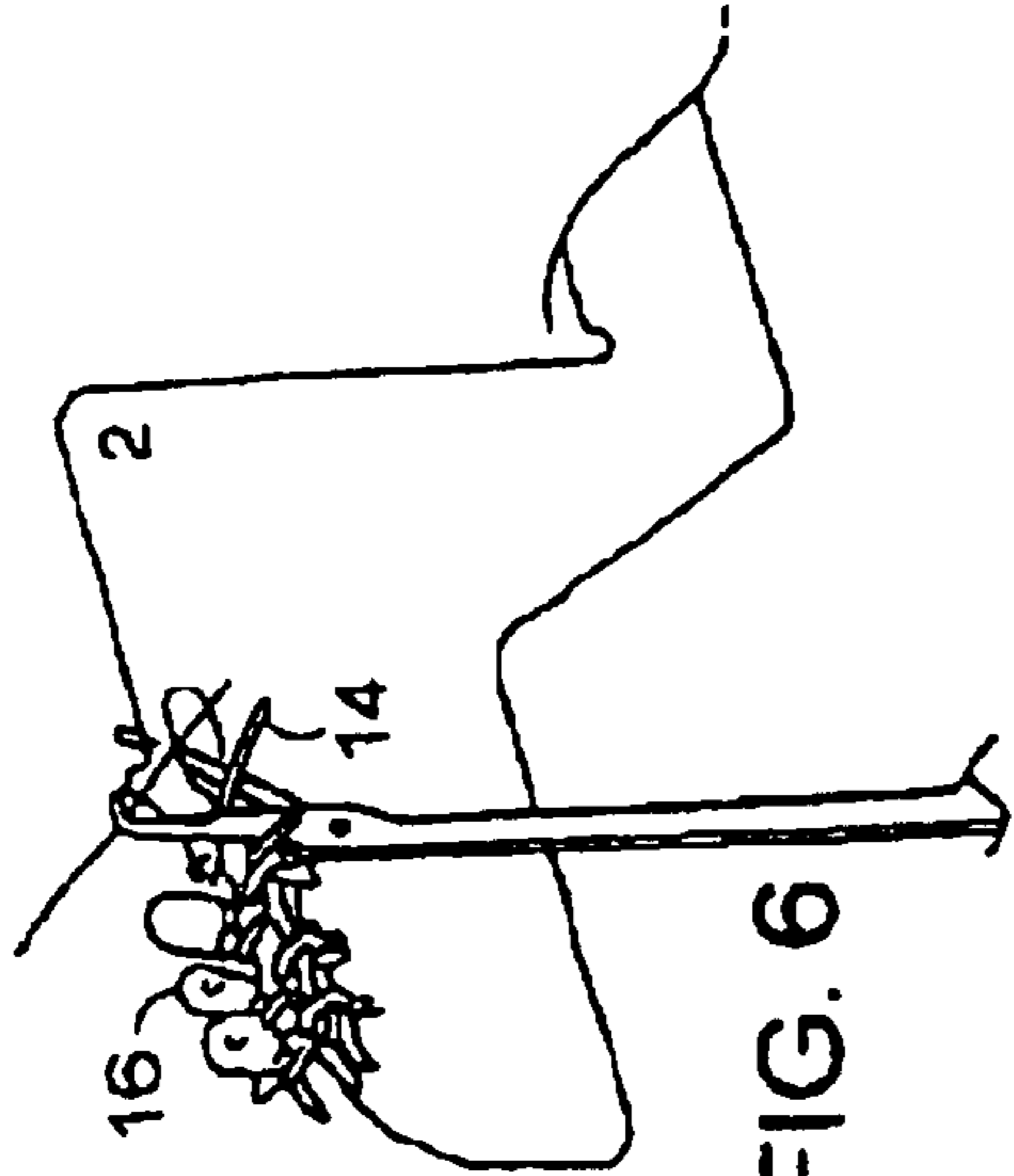

FIG. 6

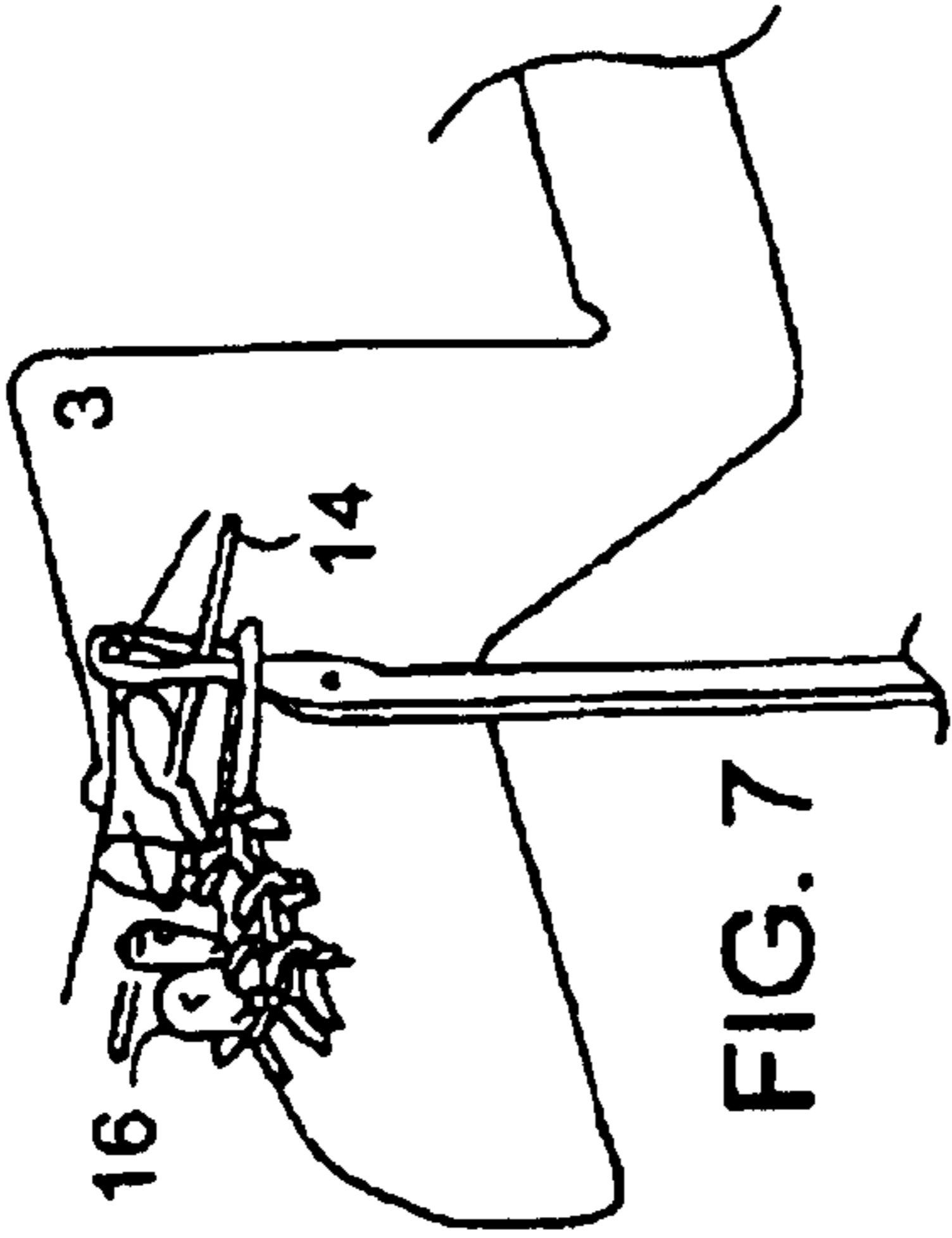

FIG. 7

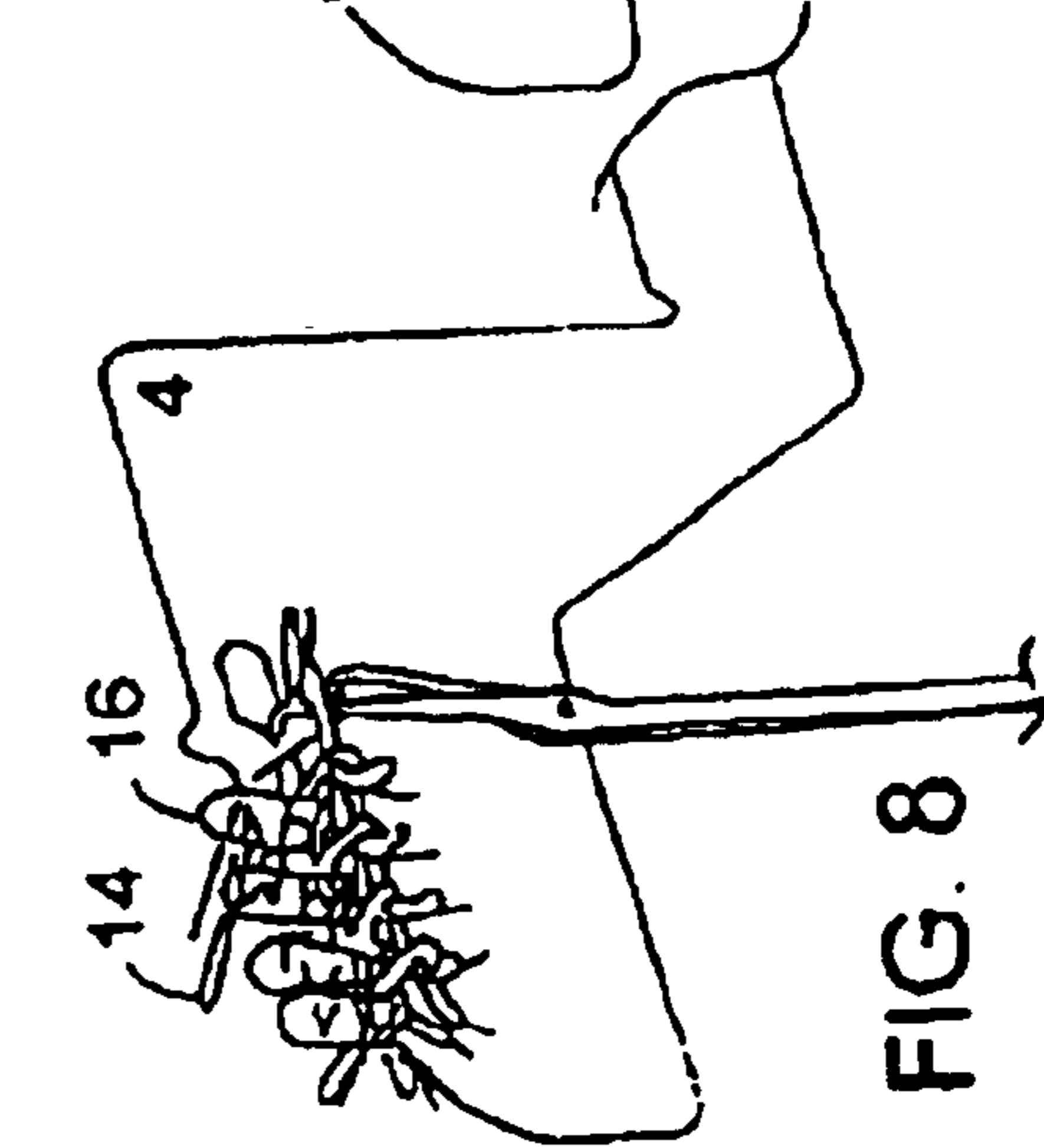

FIG. 8

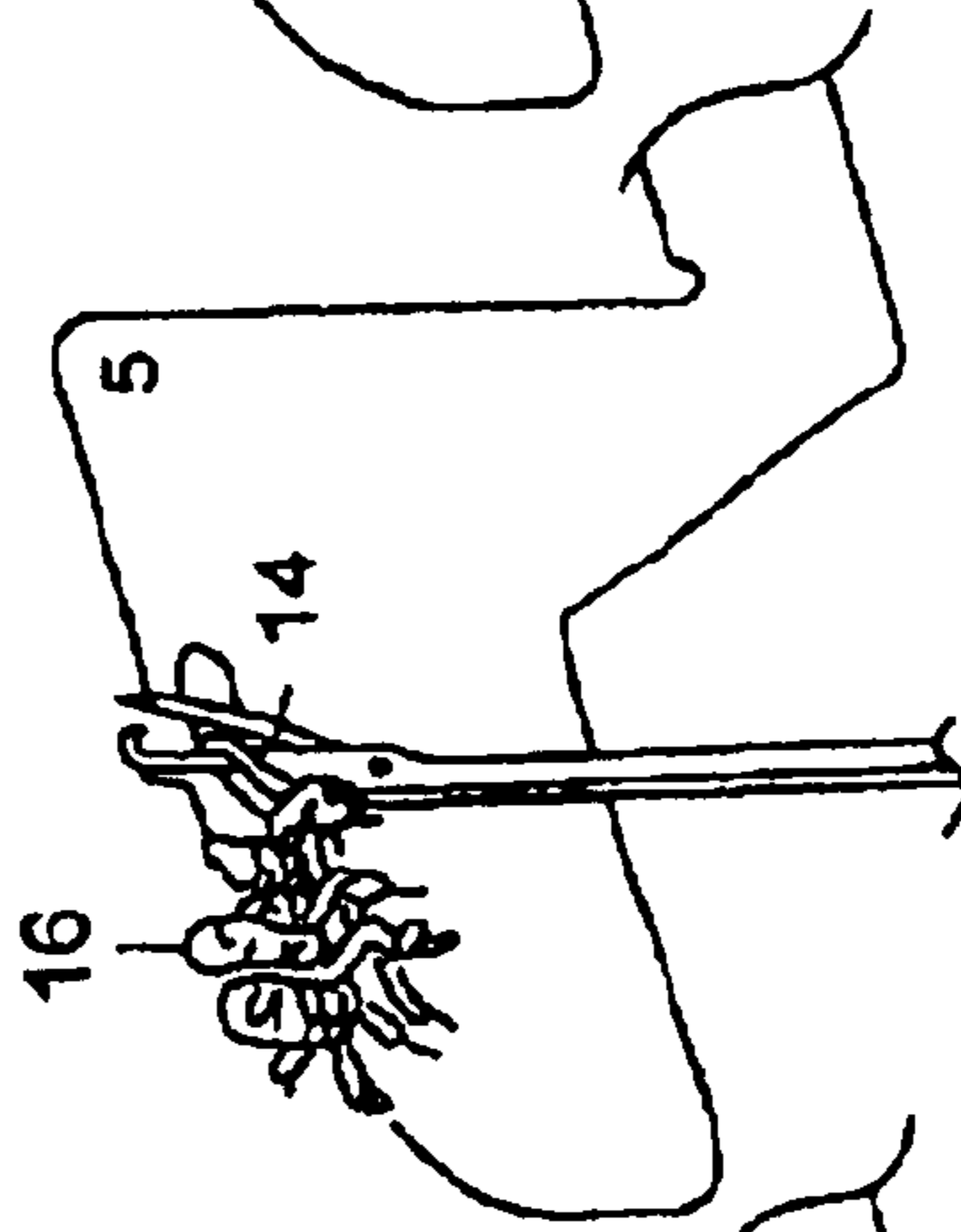

FIG. 9

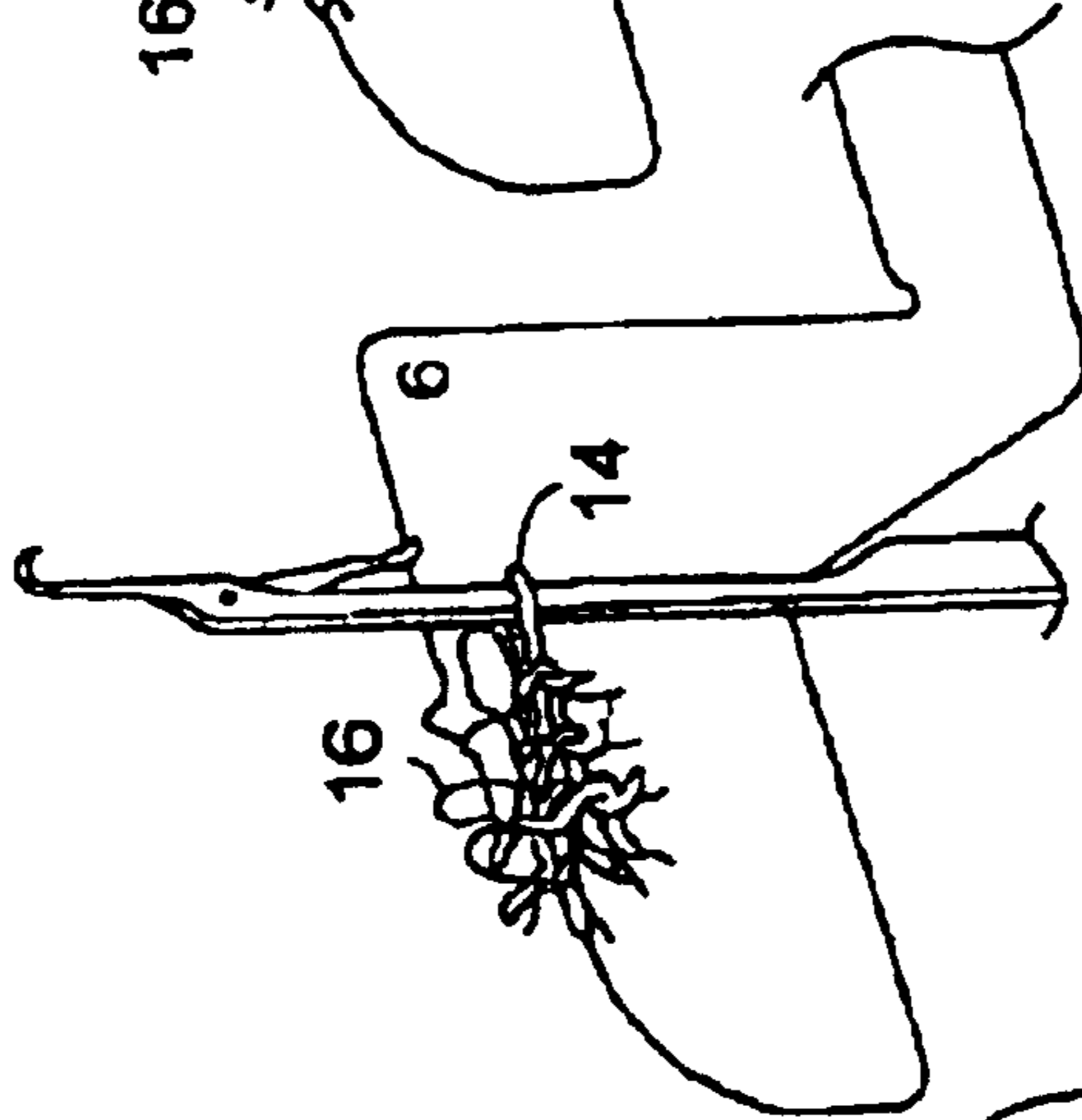

FIG. 10

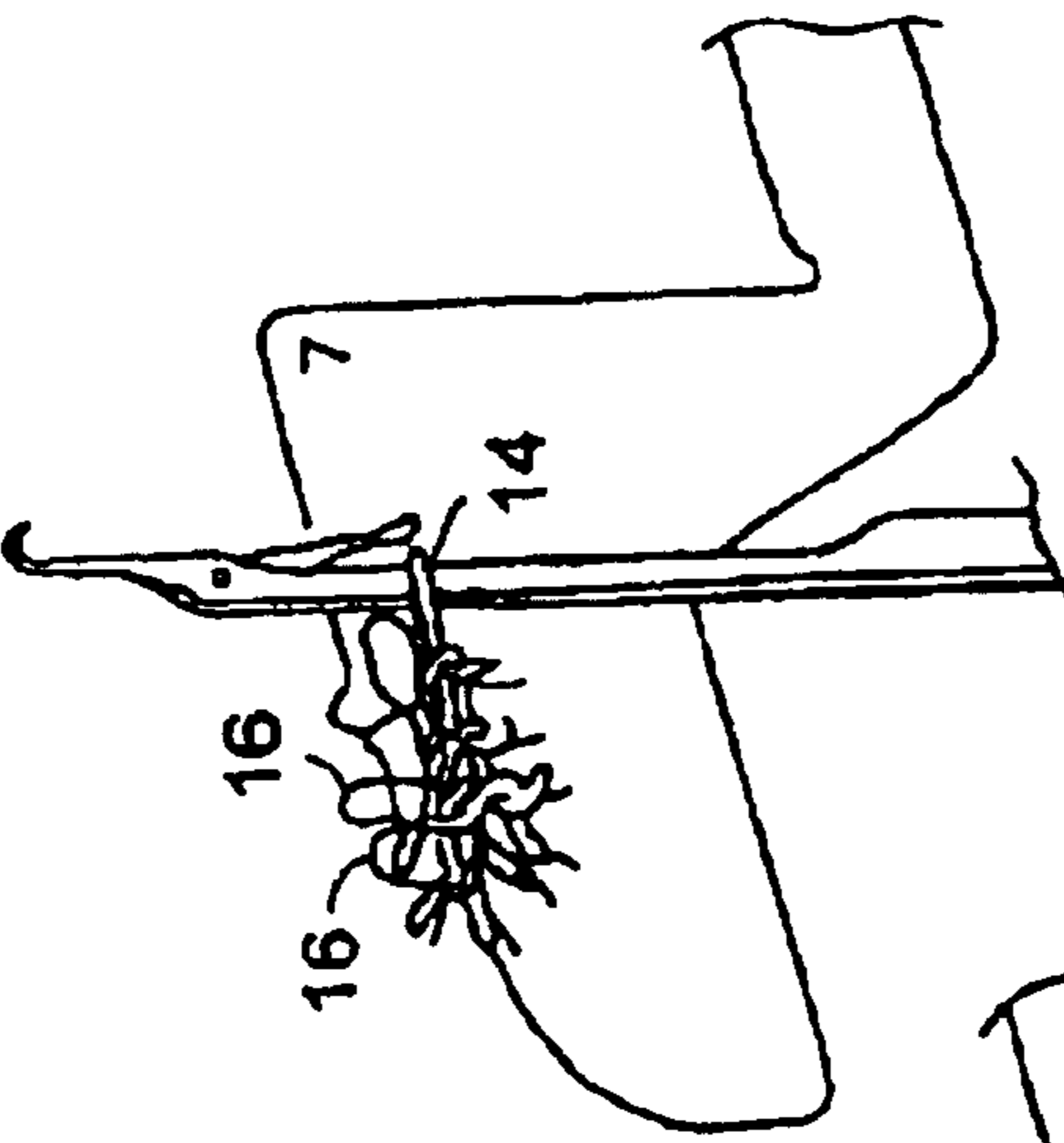

FIG. 11

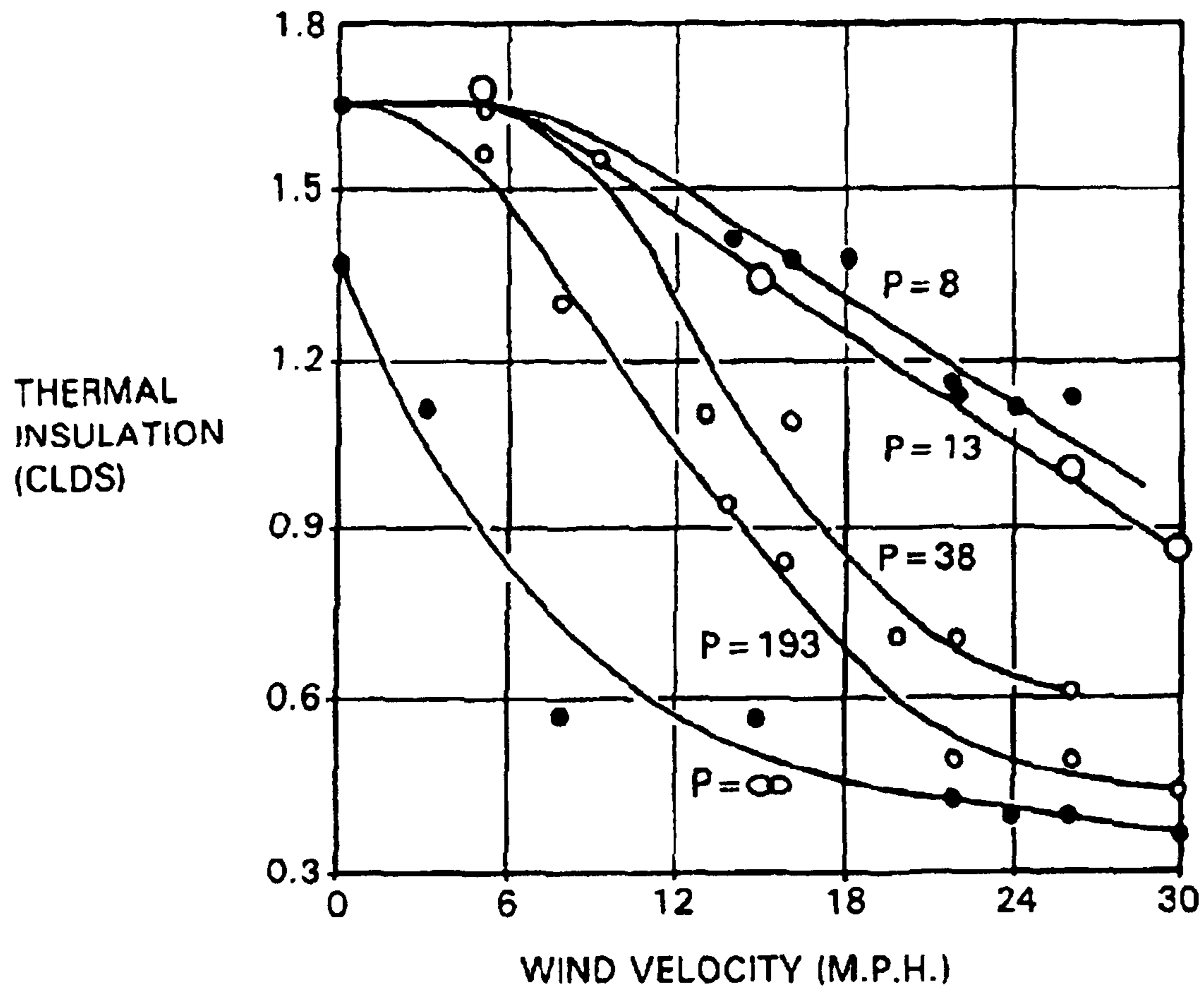

FIG. 14

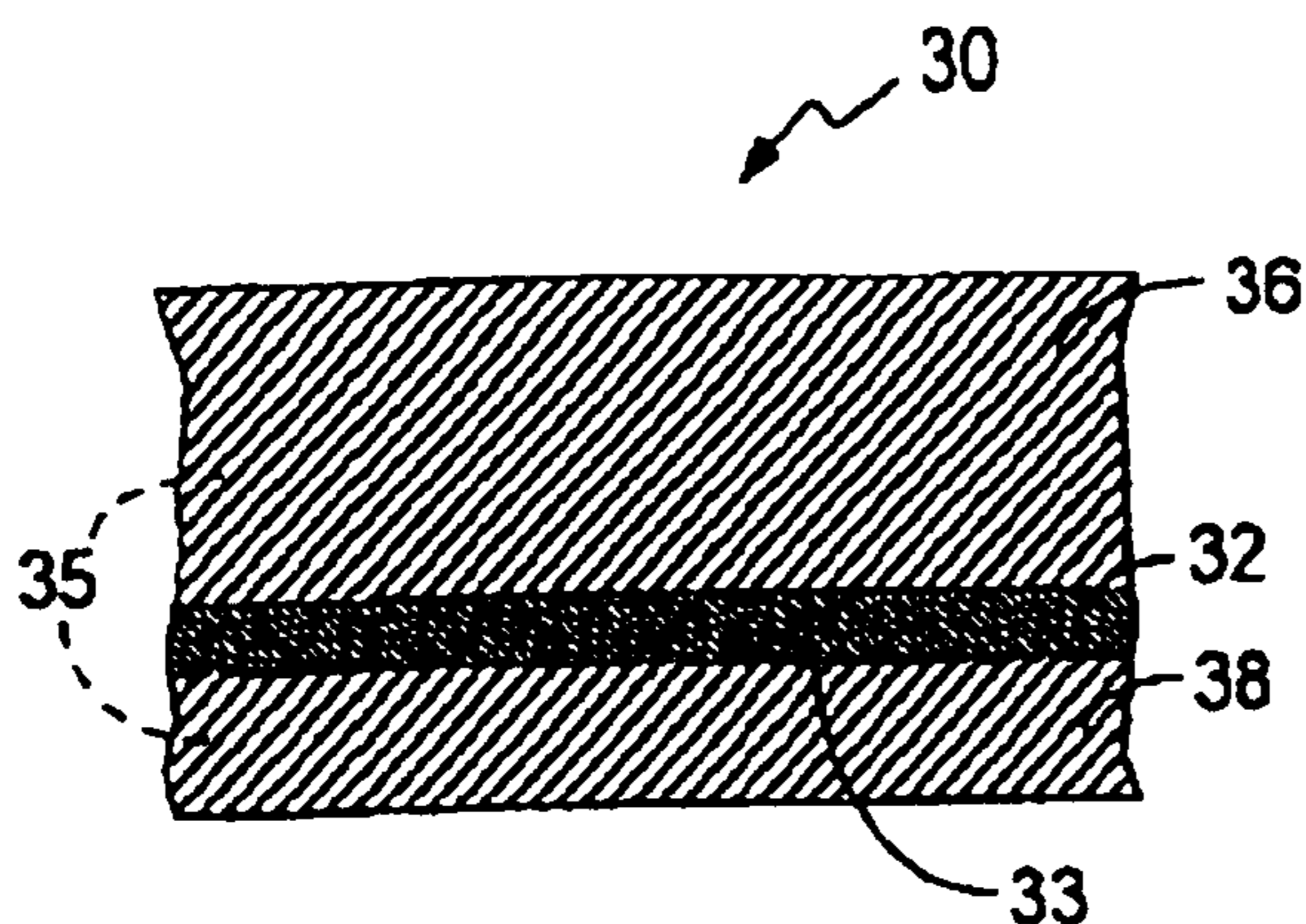

FIG. 15

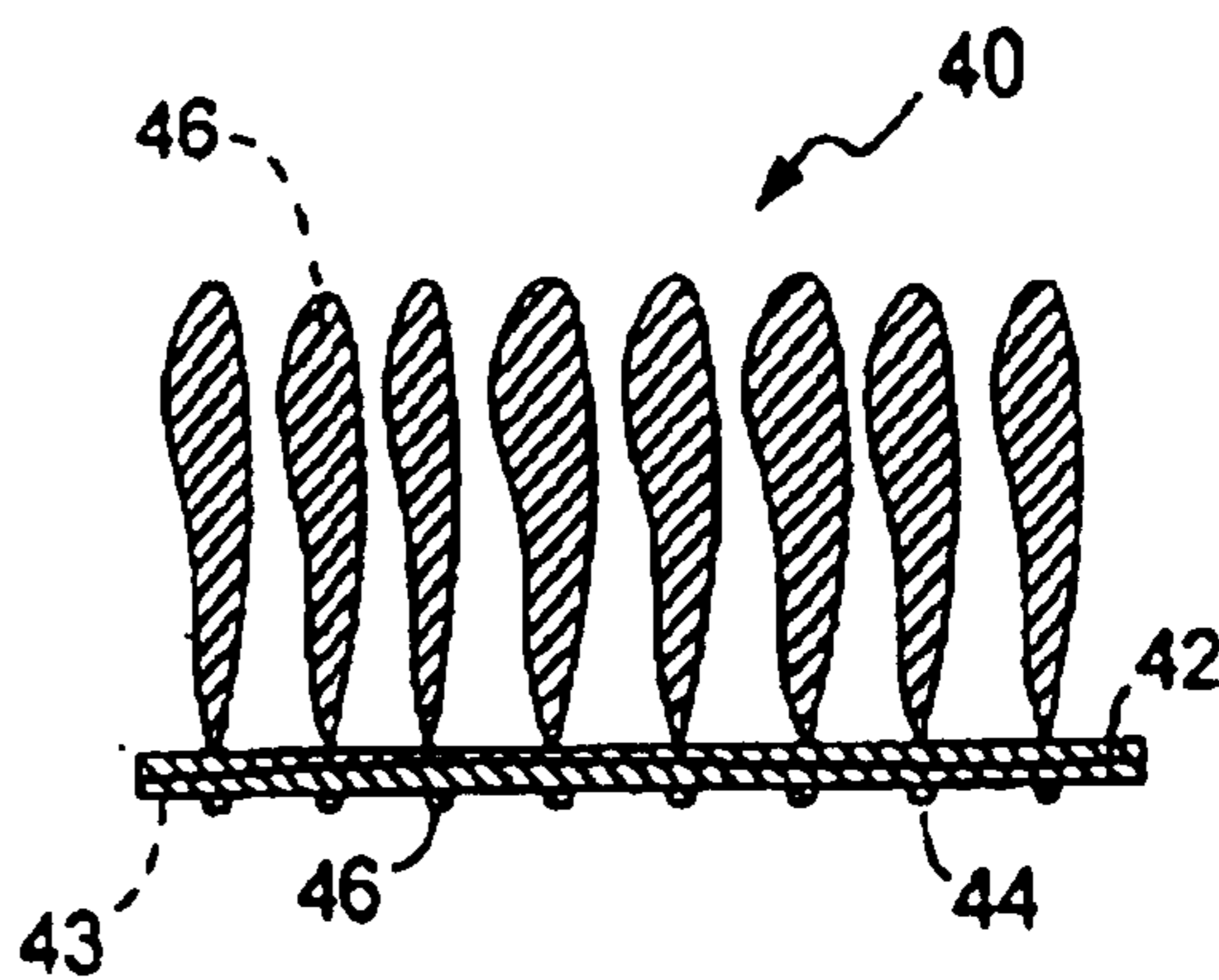

FIG. 16

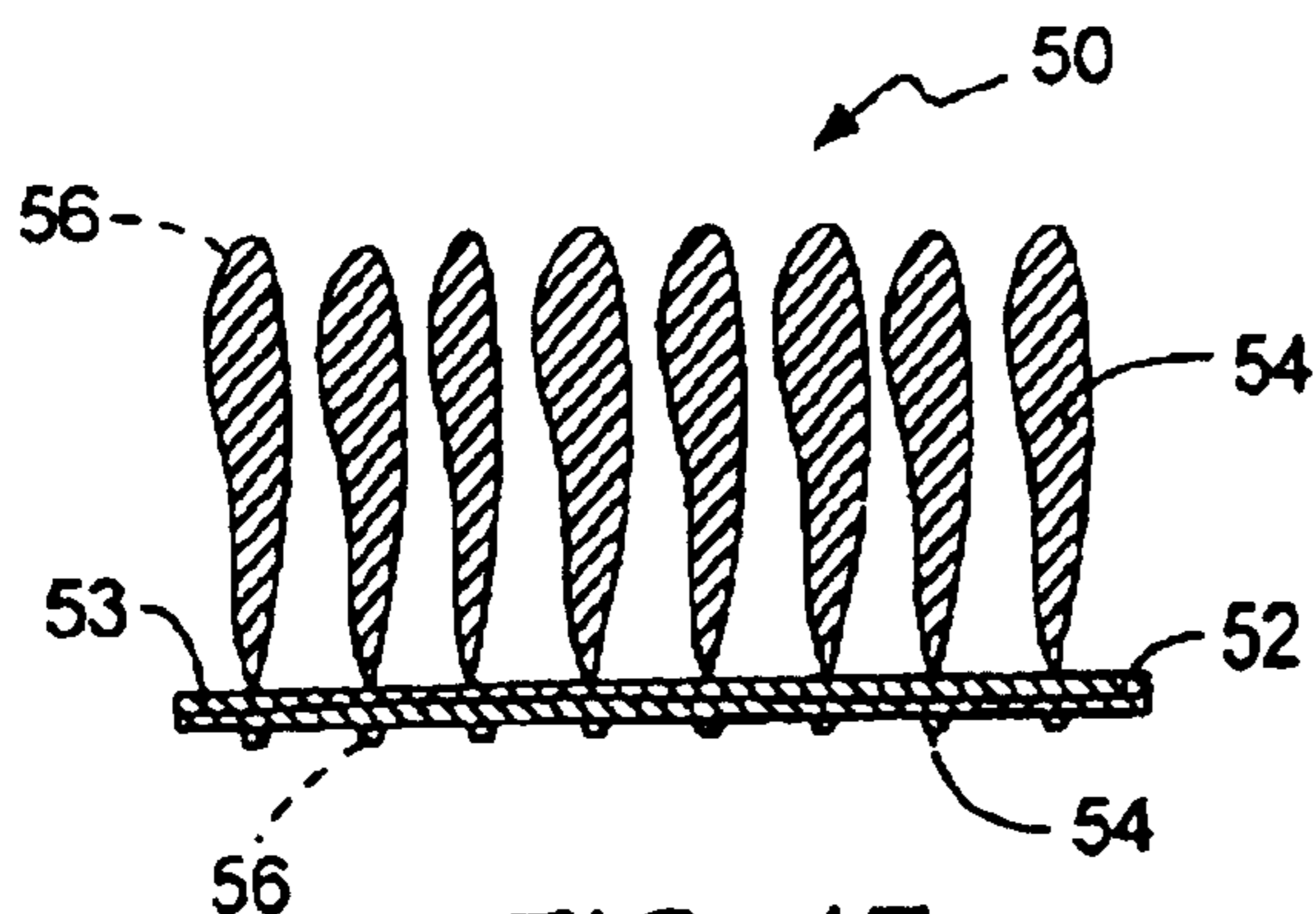

FIG. 17

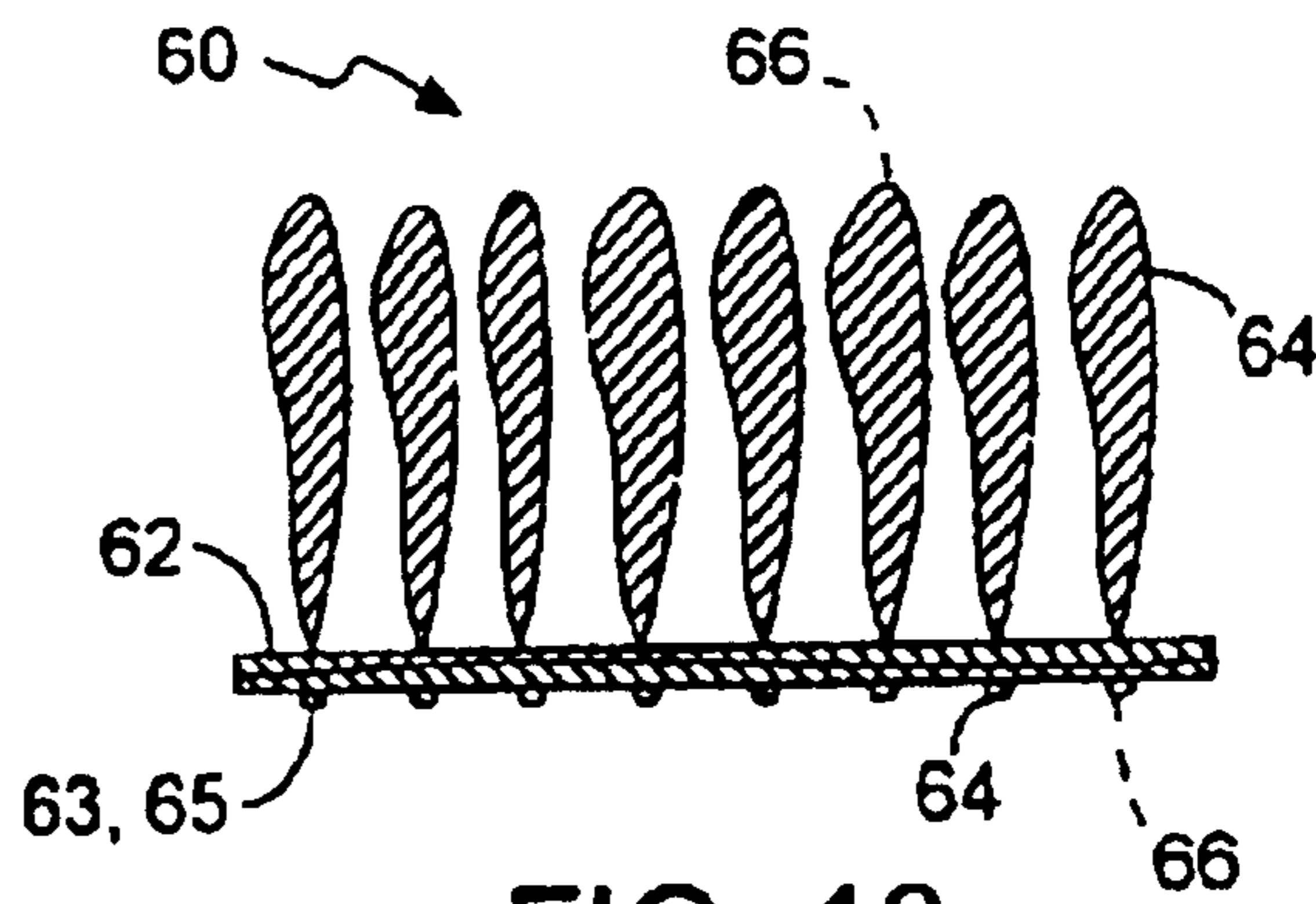

FIG. 18

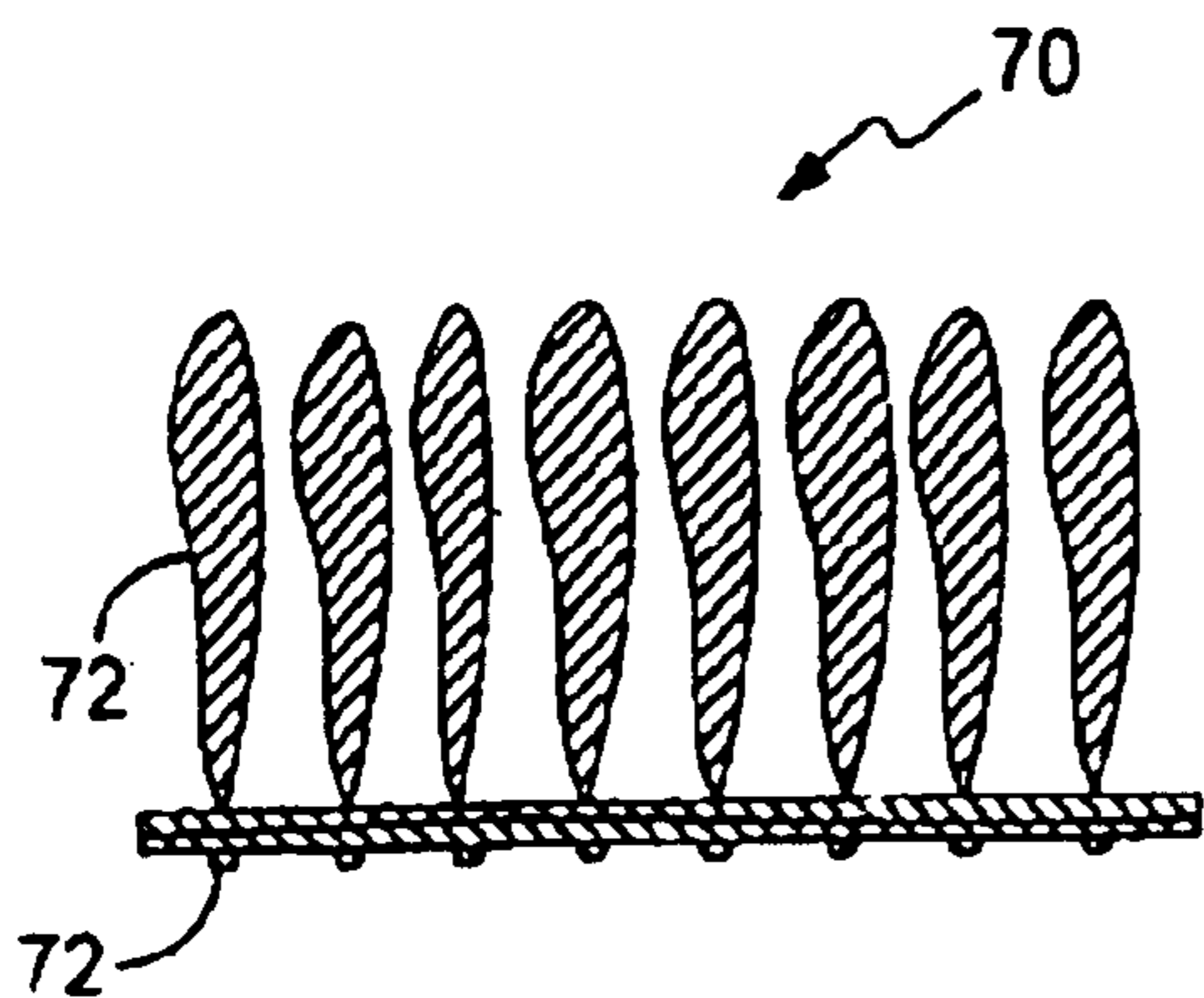

FIG. 19

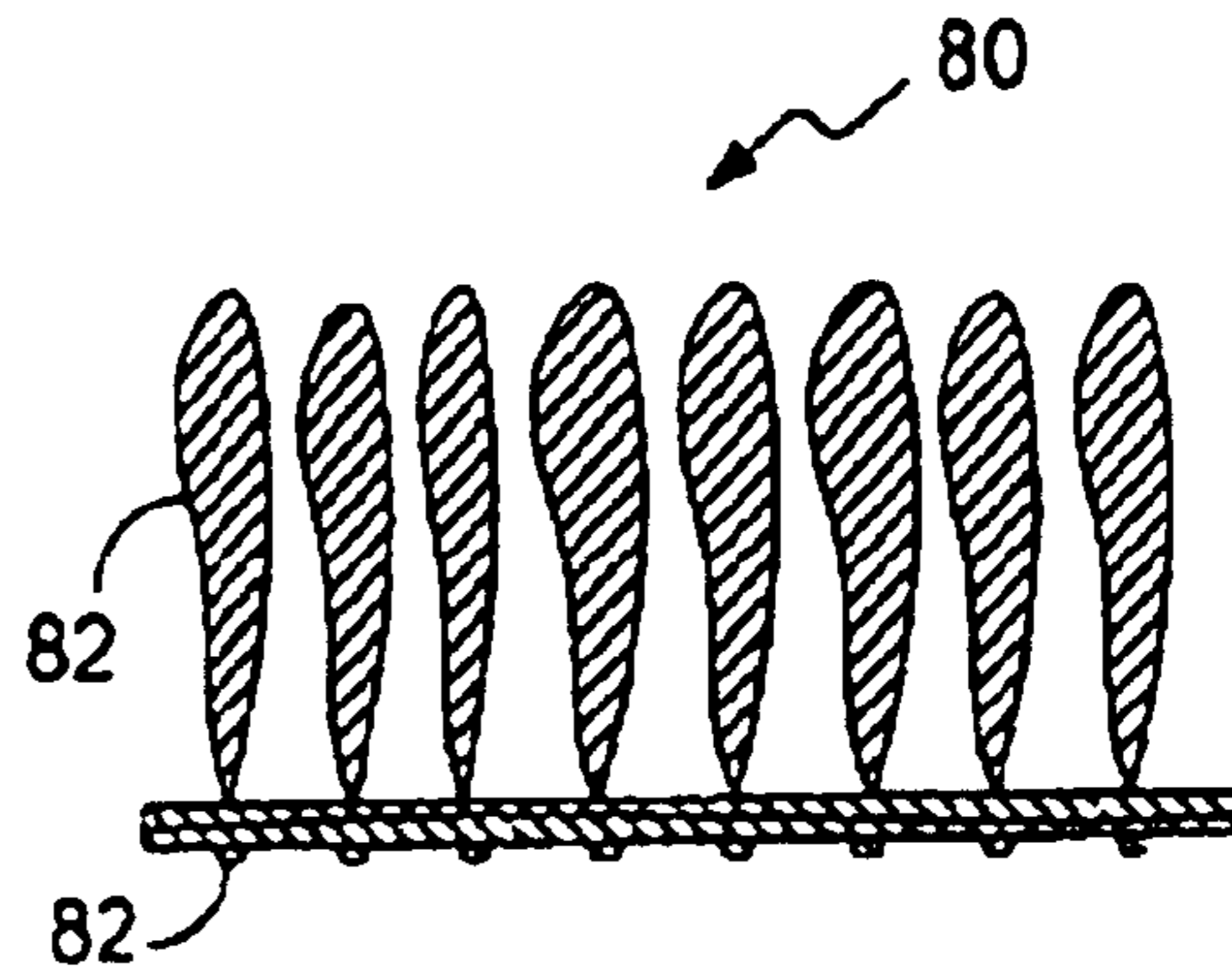

FIG. 20

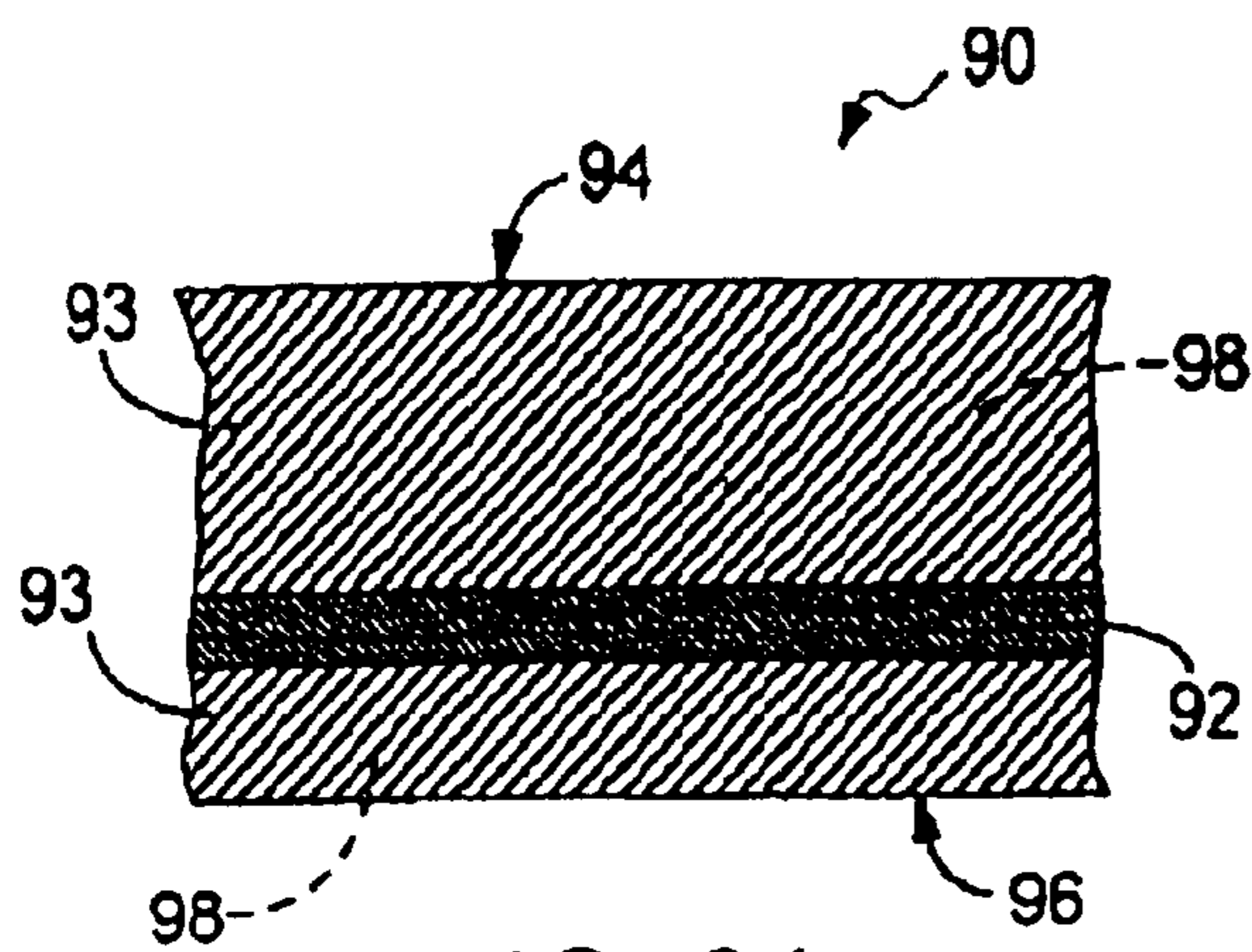

FIG. 21

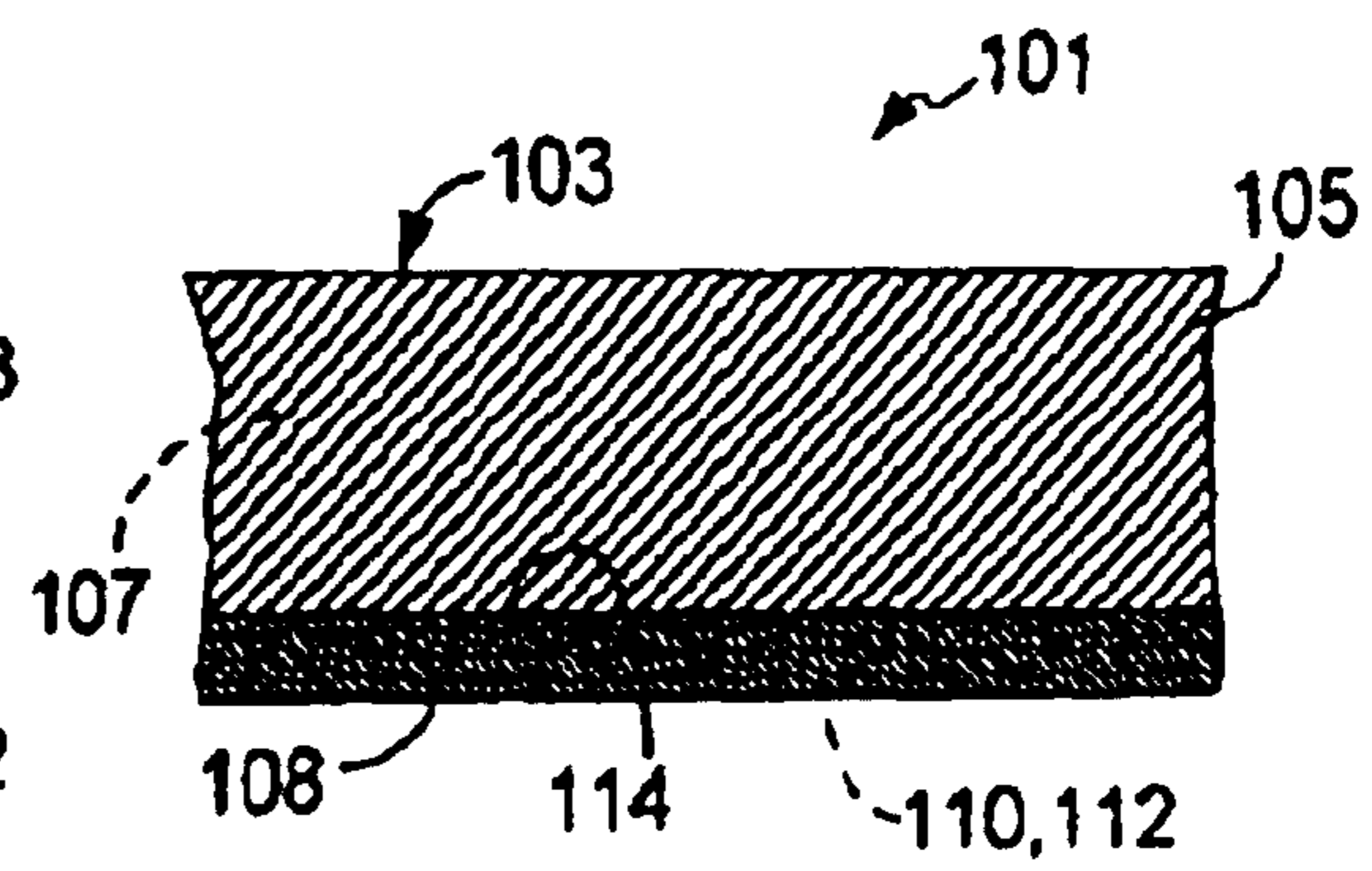

FIG. 22

**VELOUR FABRIC ARTICLES HAVING
FLAME RETARDANCE AND IMPROVED
DYNAMIC INSULATION PERFORMANCE**

Matter enclosed in heavy brackets [] appears in the original patent but forms no part of this reissue specification; matter printed in italics indicates the additions made by reissue.

This application is a continuation-in-part of U.S. application Ser. No. 09/982,720, filed Oct. 18, 2001, which is a continuation-in-part of U.S. application Ser. No. 09/883,643, filed Jun. 18, 2001, now abandoned, which is a division of U.S. application Ser. No. 09/347,825, filed Jul. 2, 1999, now abandoned, the entire disclosures of all of which are incorporated herein by reference.

This invention relates to velour fabric articles, and, more particularly, to velour fabric articles having improved dynamic insulation performance due to relatively greater densification and tortuosity, and improved flame retardance.

BACKGROUND

Velour fabric articles having one or more fleece or raised surface regions at one surface or at both surfaces, e.g., achieved by processes of sanding, brushing and/or napping of exposed fibers, are known to have good insulation performance under static conditions, i.e., in calm or still air with no wind blowing through the fabric. However, the insulating performance of these fabric articles drops rapidly under dynamic conditions, i.e., in a chilling wind. As a result, a consumer wearing a velour fabric article will often find it necessary to also wear a shell, e.g., of woven nylon or other low permeability material, when conditions are likely to be windy.

It is also known to increase the thermal insulation performance of velour fabric articles by incorporating a relatively coarser stitch yarn and/or by tightening the stitch. However, these approaches result in fabric articles with very poor stretch, increased stiffness and increased weight.

SUMMARY

According to one aspect of the invention, a double-face velour fabric article comprises a fabric body having a technical face formed by a filament stitch yarn and a technical back formed by a loop yarn, the filament stitch yarn comprising heat sensitive material and the loop yarn comprising flame retardant material, the fabric body having a velour surface formed at one or both of the technical back and the technical face, and the heat sensitive material responding to application of heat during processing to increase tortuosity with a result of the fabric body having permeability of about 90 ft³/ft²/min or less under a pressure difference of ½ inch of water across the fabric body (according to the testing method of ASTM Designation: D 737-96, "Standard Test Method for Air Permeability of Textile Fabrics," the entire disclosure of which is incorporated herein by reference).

Preferred embodiments of this aspect of the invention may include one or more of the following additional features. The flame retardant material comprises m-Aramid fibers. The heat sensitive material is preferably selected from the group consisting of polypropylene, polyester, and polyamide. The heat sensitive material comprises heat shrinkable material, preferably selected from the group consisting of polypropylene, nylon, and polyester. The heat sensitive material responds to application of dry heat and/or to

application of wet heat, e.g. steam or hot water, e.g. at about 212° F. to about 450° F. applied for about 2 minutes to about 60 minutes. The filament stitch yarn comprises elastomeric material, e.g. spandex. Filaments of the heat sensitive material and filaments of the elastomeric material are commingled or plaited together. The filament stitch yarn is a cored yarn comprising a core and a sheath, the sheath comprising hot melt material. The core material is preferably selected from the group consisting of polyester and nylon, and the hot melt material is preferably selected from the group consisting of polypropylene, polyester and polyamide. The loop yarn is split, e.g. by application of heat, e.g. the loop yarn of fine denier fibers or filaments comprises an "islands-in-sea" construction, or by application of a chemical, e.g. caustic soda, or by mechanical action, e.g. napping, to release multiple small diameter filaments. The loop yarn and/or the filament stitch yarn are textured. Raised fibers of the velour surface, of at least one of the technical face and the technical back, are entangled, including in and/or through interstices of the fabric body toward the other of the technical face and the technical back. Raised fibers of the technical back are entangled, including in and/or through interstices of the fabric body, toward the technical face. The fabric body has a velour surface region formed at the technical back or the fabric body has a velour surface region formed at each of the technical back and the technical face.

According to another aspect of the invention, a double-face velour fabric article comprises a fabric body having a technical face formed by a filament stitch yarn and a technical back formed by a filament loop yarn or spun loop yarn, the filament stitch yarn comprising elastomeric material and the loop yarn comprising flame retardant material, the fabric body having a velour surface formed at one or both of the technical back and the technical face, and the fabric body having permeability of about 90 ft³/ft²/min or less under a pressure difference of ½ inch of water across the fabric body.

Preferred embodiments of both of these aspects of the invention may include one or more of the following additional features. The flame retardant material comprises m-Aramid fibers. The elastomeric material comprises spandex. The fabric body has permeability of about 70 ft³/ft²/min or less. Raised fibers of the velour surface of at least one of the technical face and the technical back is entangled, including in and/or through interstices of the fabric body toward the other of the technical face and the technical back. Preferably, raised fibers of the technical back are entangled, including in and/or through interstices of the fabric body, toward the technical face.

According to yet another aspect of the invention, a method of forming a velour fabric body comprises the steps of: joining a filament or spun loop yarn and a filament stitch yarn to form a fabric prebody, the filament stitch yarn forming a technical face of the fabric prebody and the loop yarn forming a technical back of the fabric prebody, the filament stitch yarn comprising heat sensitive material and the loop yarn comprising flame retardant material, finishing at least one of the technical face and the technical back of the fabric prebody, thereby to form a velour fabric body having at least one velour surface region, entangling raised fibers of at least one of the technical face and the technical back, including in and/or through interstices of the fabric body, thereby to increase density and tortuosity of the fiber body, the fabric body having permeability of about 90 ft³/ft²/min or less under a pressure difference of ½ inch of water across the fabric body.

Preferred embodiments of this aspect of the invention may include one or more of the following additional fea-

tures. The method comprises the further step of entangling the raised fibers in a process of hydroentanglement, by directing fine, high-pressure jets upon at least one of the technical face and the technical back. The method comprises the further step of directing fine, high-pressure jets upon the technical back, to cause raised fibers of the velour surface of the technical back to entangle, including in and/or through interstices of the fabric body, toward the technical face. The filament stitch yarn comprises heat sensitive material, and the method comprises the further step of exposing said fabric body to heating sufficient to cause a response by the heat sensitive material, thereby to increase tortuosity. The method comprises the further step of entangling the raised fibers in a process of hydroentanglement, by directing fine, high-pressure water jets upon at least one of the technical face and the technical back. The method comprises the further step of directing fine, high pressure jets (e.g., water jets or air jets) upon the technical back, to cause raised fibers of the velour surface of the technical back to entangle, including in and/or through interstices of the fabric body, toward the technical face. The method comprises the step of finishing the technical face and the technical back of the fabric prebody, thereby to form a velour fabric body having velour regions at opposite surfaces. The method comprises exposing the fabric body to the heating sufficient to cause a response by the heat sensitive material during dyeing and/or during finishing. The method comprises exposing the fabric body to dry heat and/or to wet heat, e.g. steam or hot water. The method comprises exposing the fabric body to heating sufficient to cause a response by the heat sensitive material for about 2 minutes to about 60 minutes at about 212° F. to about 450° F. The method comprises exposing the fabric body to heating sufficient to cause a response by the heat sensitive material, thereby to increase tortuosity with a result of the fabric body having permeability of about 70 ft³/ft²/min or less. The method comprises joining a loop yarn and a filament stitch yarn, the filament stitch yarn comprising elastomeric material, e.g., spandex.

An objective of the invention is to provide velour fabric articles having flame retardance and improved dynamic insulation performance while avoiding increased weight and/or loss of stretch and/or loss of flexibility. A further objective is to provide velour fabric articles that may be worn in chilling, windy conditions without markedly diminished insulation performance. Generally, tortuosity, and therefore density, is increased by using heat-sensitive and/or elastomeric materials in the stitch yarns and entangling the loop yarn fibers. The improved dynamic insulation performance achieved in conditions of relative wind speed (i.e., wind blowing and/or movement of the wearer in relation to ambient atmosphere) enhances flame retardance properties by allowing less air to penetrate through the fabric construction. Thus flame retardance is enhanced, e.g. in accordance with very stringent flame retardance requirements of the protective cloth and military markets, e.g., as set forth in NFPA 1975-94 (the complete disclosure of which is incorporated herein by reference), by including fibers of inherent flame retardant material, e.g., m-Aramid fibers (NOMEX®, as available from E. I. du Pont de Nemours and Company, of Wilmington, Del.) in the loop yarn of fleece or raised surface regions of the resulting velour fabric articles.

The details of one or more embodiments of the invention are set forth in the accompanying drawings and the description below. Other features, objects, and advantages of the invention will be apparent from the description and drawings, and from the claims.

DESCRIPTION OF DRAWINGS

FIG. 1 is a somewhat diagrammatic end section view of a double-face fabric prebody, e.g., as formed in a reverse plaiting circular knitting process.

FIG. 2 is a somewhat diagrammatic end section view of a double-face velour fabric article of the invention formed by finishing the double-face fabric prebody of FIG. 1; and

FIG. 3 is a somewhat diagrammatic end section view of a prior art double-face velour fabric article that is comparable to the double-face velour fabric article of FIG. 2.

FIG. 4 is a perspective view of a segment of a circular knitting machine, and

FIGS. 5-11 are sequential views of a cylinder latch needle in a reverse plaiting circular knitting process, e.g., for use in forming the double-face fabric prebody of FIG. 1.

FIG. 12 is a somewhat diagrammatic end section view of a double-face velour fabric article being subjected to a process of hydroentanglement; and

FIG. 13 is a similar, somewhat diagrammatic end section view of a resulting double-face velour fabric article of the invention, having improved dynamic insulation performance.

FIG. 14 is a plot of curves showing the relationship between change in effective thermal insulation and wind velocity for covers or fabrics of different permeability (P. Larose, "The Effect of Wind on the Thermal Resistance of Clothing with Special Reference to the Protection Given by Coverall Fabrics of Various Permeabilities," Canadian Journal of Research, Vol. 25, Sec. A, No. 4, (July 1947), pp. 169-190).

FIGS. 15-20 are somewhat diagrammatic end section views of other embodiments of double-face velour fabric articles of the invention formed of filament stitch yarns and/or loop yarns including or consisting largely of materials with characteristics selected for improving dynamic insulation performance of the fabric article, namely heat sensitive materials, elastic materials and/or combinations thereof;

FIG. 21 is a somewhat diagrammatic end section view of an alternative embodiment of a double-face velour fabric article of the invention formed of loop yarns including, or consisting largely of, materials with characteristics selected for improving flame retardance; and

FIG. 22 is a somewhat diagrammatic end section view of another alternative embodiment of a velour fabric article of the invention having raised or fleece surface region(s) formed at a single surface by finishing fibers of loop yarns including, or consisting largely of, materials with characteristics selected for improving flame retardance.

Like reference symbols in the various drawings indicate like elements.

DETAILED DESCRIPTION

Referring to FIG. 1, a double-face fabric prebody 12, e.g., for use in forming a double-face velour fabric article 10 of the invention (FIG. 2), is formed by joining a stitch yarn 14 and a loop yarn 16 in a standard reverse plaiting circular knitting (terry knitting) process (see FIGS. 4-11, including a depiction of the position of the latch needle at seven different time points 1-7, shown together in FIG. 4, and individually in FIGS. 5-11), e.g., as described in *Knitting Technology*, by David J. Spencer (Woodhead Publishing Limited, 2nd edition, 1996), the entire disclosure of which is incorporated herein by reference. In the terry knitting process, the stitch yarn 14 forms the technical face 18 of the resulting fabric prebody 12 and the loop yarn 16 forms the opposite technical back 20, where it is formed into loops 22. In the fabric prebody 12 formed by reverse plaiting circular knitting, the loop yarn 16 extends outwardly to overlie and cover the stitch yarn 14 at the technical face 18.

The loop yarn **16** forming the technical back **20** of the knit fabric body **12** can be made of any synthetic or natural material. The cross section and luster of the fibers or filaments may be varied, e.g., as dictated by requirements of the intended end use. The loop yarn **16** can be a textured or flat filament or, preferably, a yarn of fine denier filaments or fibers (e.g., 1.5 dpf or lower), with a textured yarn being preferred for relatively greater dynamic insulating effect, as discussed below. The loop yarn overall denier is typically in the range of about 70 denier to 300 denier, with a preferred count of about 150 denier. At the preferred count, the filament count range is from about 100 filaments to 300 filaments, therefore providing a denier per filament (dpf) of from 1.5 to 0.5, respectively. A relatively smaller dpf, e.g. 1 dpf, is preferred for relatively greater dynamic insulating effect, as will be discussed below. A preferred commercial loop yarn is a 150/132 denier textured polyester yarn of fine denier filaments or fibers with a dpf of 1.14, e.g. as available from UNIFI, Inc., of Greensboro, N.C.

The stitch yarn **14** forming the technical face **16** of the knit fabric body **12** can be also made of any type of synthetic or natural material in a textured or flat filament yarn, with a textured yarn being preferred for relatively greater dynamic insulating effect. The range of stitch yarn count denier is typically between about 50 denier to 150 denier. Where the loop yarn is 150/132 textured, the preferred stitch yarn count is about 100 denier, and the filament count ranges from about 34 filaments to 200 filaments, i.e. 100/34 to 100/200, resulting in dpf from about 3 dpf to 0.5 dpf, with relatively finer filaments being preferred, again, for relatively greater dynamic insulating performance. A preferred stitch yarn is 100/136 denier textured polyester with about 0.7 dpf, e.g. as available commercially from UNIFI, Inc. Another preferred yarn is 130/408 denier textured polyester with about 0.3 dpf, e.g. as available from Hyosung, Inc., of Seoul, Korea.

From these examples, it can be seen that, for achieving markedly improved dynamic insulating performance, use of a textured 150/132 loop yarn and a textured 100/136 stitch yarn is preferred.

In comparison, in a prior art double-face velour fabric article (**100**, FIG. **3**) without the improved dynamic insulation performance of the present invention, a typical stitch yarn **102** is 70/34 denier filament textured polyester, with individual fiber fineness of greater than 2.0 dpf, e.g. as available commercially from UNIFI, Inc.

In a preferred method of the invention, the fabric prebody **12** is formed by reverse plaiting on a fine cut circular knitting machine (e.g., 28 cut). This is principally a terry knit construction, where segments **22** of the loop yarn **16** cover the stitch yarn **14** on the technical back **20** and loops **23** of the loop yarn **16** form loops **23** at the technical face **18** of the fabric prebody **12** (see FIG. **1**).

The fabric prebody **12** is next subjected to finishing. During the finishing process, the technical face and technical back surfaces **18**, **20**, respectively, of the fabric prebody **12**, with the segments **22** of loop yarn **16** overlying the stitch yarn **14** at the technical face surface **18** and the loops **23** formed at the technical back surface **20**, go through a finishing process such as sanding, brushing and/or napping, to generate a velour **24**, **26**. The yarn fibers are raised at both faces of the fabric prebody **12** (FIG. **1**), including the technical face **18** and the technical back **20**, to form the velour **24**, **26** at each face of the fabric body **30** of the double-face velour fabric article **10** (FIG. **2**) of the invention. The fabric prebody **12** and/or fabric body **10** may also be treated, e.g., chemically, to make it hydrophobic.

Referring to FIG. **12**, after finishing, the fabric article **10** is next subjected to a process of hydroentanglement, such as employed in fabrication of spun staples yarn and in the fabrication of non-woven fabrics. During this process, fine, high-pressure water jets **32** (or air jets) are directed onto, e.g., the technical back **20** of the fabric article **10**. In this manner, raised fibers **34** of the velour surface of the technical back **20** are entangled, including in and/or through interstices of the fabric body **30**, toward the technical face **18**. The hydroentanglement process thus serves to densify the velour surface, resulting in the double-face fabric article **40** (FIG. **13**), advantageously, without substantial increase in bulk or thickness, for improved dynamic insulation, i.e. against through-flow of air, e.g., in a chilling wind. By way of example only, after finishing, the technical back **20** of a double-face velour fabric article **10** may be treated by hydroentanglement using fine, high-pressure water jets **32**, e.g., with water applied at 100 m/sec to 350 m/sec through jets having apertures of 0.01 mm to 1.0 mm diameter. Alternatively, raised fibers of the technical face may be entangled in and/or through interstices of the fabric body, toward the technical back.

Entangling raised fibers of the technical back, i.e., of the loop yarn, including in and/or through interstices of the fabric body, toward the technical face, results in relatively greater densification and therefore greater tortuosity, e.g., as compared to entanglement of raised fibers of the technical face, including in and/or through interstices of the fabric body, toward the technical back. Entangling from back to face, in addition to resulting in a relatively greater increase in tortuosity, also increases smoothness of the fabric/garment outer surface, while entangling from face to back increases tortuosity and increases smoothness of the fabric/garment inner surface.

Fabric performance and aesthetics of the fabric article **40** can also be adjusted by selection of knitting gauge (e.g., in the range of about 18 to about 36, and preferably about 28), yarn type (e.g., preferably textured, or flat filament), yarn denier (e.g., about 70 to about 300, and preferably about 100), fiber denier (e.g., about 0.3 to about 1.5, and preferably about 1.0), etc. Adjustment of jet speed and/or aperture size, e.g., within the ranges mentioned above, can further or instead be employed to adjust fabric performance and/or aesthetics.

The fabric article **40** is thereafter heat set to stabilize the fabric article width.

In this and other embodiments of the invention described below, heat may be applied to the fabric body, e.g. dry heat and/or wet heat, such as hot water or steam, e.g. during finishing or dyeing. As mentioned elsewhere, the stitch yarn (and/or the loop yarn) may include heat sensitive and/or elastomeric materials.

In a resulting double-face velour fabric article **10** of this embodiment of the invention, the overall density, i.e., weight per length, of the filament stitch yarn **14** is closely comparable to stitch yarn **102** used in a comparable prior art fabric article **100** having velour **104**, **106** at the opposite faces. The diameter of the filament stitch yarn **14** may be slightly greater than that of the prior art stitch yarn **102** (likely due to increased filament-to-filament engagement of the filaments of the filament stitch yarn **14**). The yarn count and gauge of the double-face velour fabric article **10** of the invention are also substantially the same as those for the comparable prior art fabric article **100**. As a result, the weight and stretch performance of the double-face velour fabric article **10** of the invention is closely comparable to the

weight and stretch of the prior art double-face velour fabric article **100** of the same gauge and yarn count.

The fact that the weight density of the filament stitch yarn **14** and the stitch yarn **102** are the same indicates that the ratio of yarn material to open volume for each of the respective articles is also approximately the same. However, in the filament stitch yarn **14**, and in the resulting double-face velour fabric article **10** of the invention, the average cross sectional area of the individual filaments is considerably less than the average cross sectional area of filaments in the stitch yarn **102** employed in the comparable prior art fabric article **100**, e.g., the denier per filament (dpf) of the preferred filament stitch yarn **14** is about 0.7 dpf, as compared to 3.0 dpf for the stitch yarn **102** of comparable prior art fabric article **100**. As a result, the paths for passage of air, e.g., a chilling wind, through double-face velour fabric article **10** of the invention, while relatively more numerous, are also considerably smaller and relatively more tortuous, as compared to a comparable prior art double-face velour fabric article **100**. The enhanced performance of the fabric article of the invention is achieved by increasing the yarn count and the filament count to make the paths through the fabric more tortuous, thus making it more difficult for air, i.e., a chilling wind, to penetrate quickly through the double-face velour fabric article **10** of the invention. As a result, the dynamic insulation performance of the double-face velour fabric of the invention is dramatically increased over the prior art.

In FIG. **14**, there is reproduced a plot of curves showing the relationship between change in effective thermal insulation and wind velocity for covers or fabrics of different permeabilities, as appeared in an article by P. Larose, entitled "The Effect of Wind on the Thermal Resistance of Clothing with Special Reference to the Protection Given by Coverall Fabrics of Various Permeabilities," which appeared in Canadian Journal of Research (Vol. 25, Sec. A, No. 4, (July 1947), pp. 169-190), the entire disclosure of which is incorporated herein by reference. The permeabilities of the materials tested varied between 0 and 193 ft³/ft²/min under a pressure difference of ½ inch of water across the fabric.

In particular, it can be seen in the plot that at zero wind velocity there is relatively little difference in insulating performance among the materials tested. The dynamic insulating performance for each of the materials tested also decreased with increasing wind velocity. However, as may be seen in the plot, the rate of decrease in dynamic insulating performance was much more precipitous in fabrics of relatively greater permeability, i.e. as permeability increased, the rate of loss of dynamic insulating performance with increasing wind velocity was relatively smaller for fabrics of low permeability, as compared to fabrics having relatively greater permeability.

In Table A (below), the improvement in dynamic insulation performance of double-face velour fabric articles **10** (FIG. **2**) of the invention in a chilling wind can easily be seen when compared to the performance of a comparable prior art double-face velour fabric article **100** (FIG. **3**). In particular, the double-face velour fabric article **10** of the invention has considerably better dynamic insulating performance, and good static (no wind) and dynamic (windy) insulation performance, due to the increased tortuosity of air paths through the fabric, with good stretch properties and light weight.

The word "tortuosity" is used to describe the fabric property enhanced according to this invention by increasing yarn count and filament count. The paths through the fabric

are made more "tortuous" than those of prior art fabrics, and greater "tortuosity" results in greater dynamic insulating effect. In addition, if a given fabric body is subjected to less than normal stretching, resulting in reduced final width of the fabric (i.e., the width resulting after heat setting of the fabric during the finishing process), the higher, still, the dynamic insulating performance of the resulting fabric article of the invention.

TABLE A

	A1	A2	B1	B2
Loop Yarn	150/100 textured	150/132 textured	150/100 textured	150/132 textured
Stitch Yarn	100/34 textured	100/34 textured	100/34 textured	100/34 textured
Width	58-inch cuttable	58-inch cuttable	54-inch cuttable	54-inch cuttable
"Dynamic Insulating Performance"	100-110 cfm	60-70 cfm	70-80 cfm	50-60 cfm
Compare:	A1 to A2	A2 has finer loop yarn, and therefore relatively better dynamic insulating performance.		
Compare:	A1 to B1	B1 has narrower width, and therefore better dynamic insulating performance.		
Compare:	A1 to B2	B2 has finer loop yarn, and therefore better dynamic insulating performance.		
Compare:	A1 to B2	B2 has finer loop yarn and narrower width, and therefore better dynamic insulating performance		

In other preferred embodiments, fabric articles of the invention having relatively greater densification and tortuosity, and therefore increased dynamic insulation performance for enhanced protection from wind penetration, are achieved by incorporation of stitch yarns and/or loop yarns of predetermined selected characteristics. For example, stitch yarns and/or loop yarns including, or formed largely of, heat sensitive materials, e.g. hot melt or heat shrinkable materials, and/or elastomeric materials, such as spandex, may be employed.

For example, referring now to FIG. **15**, in a preferred embodiment, a fabric article **30** of the invention formed by reverse plaiting on a fine cut circular knitting machine includes a stitch yarn **32** and a loop yarn **35** finished into a velour **36**, **38** at the opposite surfaces. The stitch yarn **32** includes, or consists largely of, yarn or filaments of heat sensitive material **33**, e.g. heat shrinkable material, or hot melt material (typically commingled (e.g., blended) with other fiber that will maintain yarn integrity after heat treatment). The loop yarn **35**, which, in this embodiment, may be a filament yarn but is more typically a spun yarn, include, or consists largely of, fibers of suitable flame retardant material, e.g., such as m-Aramide, 1.5 denier, e.g. as manufactured by E. I. du Pont de Nemours and Company, of Wilmington, Del., under the trademark NOMEX®. The m-aramide fibers may be used alone, or in a blend, e.g. with fibers of p-aramide, e.g. as manufactured by E. I. du Pont de Nemours and Company, of Wilmington, Del., under the trademark KEVLAR®, and/or with fibers of other suitable material having good electrostatic dissipation characteristics. Suitable heat sensitive materials include polypropylene, nylon, polyester, polyamide, and the like, preferably with high shrinkage, e.g., about 5% to about 50% after about 2 minutes to about 60 minutes at about 212° F. to about 450° F. Heat is thereafter applied to the fabric article, e.g., dry heat and/or wet heat, such as hot water or steam, e.g. during dyeing and/or finishing. Upon exposure to heat, the hot melt material fuses to narrow or fill interstices between the yarns

filaments, and the heat shrinkable material shortens and thickens, and/or reduces in effective length, thus to reduce the paths for passage of chilling wind through the fabric and thereby increase the tortuosity and the dynamic insulation performance of the fabric article **30** of the invention.

Referring next to FIG. **16**, in another embodiment, in a fabric article **40** of the invention, the stitch yarn **42** comprises a cored yarn **43** having a core formed, e.g., of polyester or nylon, with a sheath formed of a heat sensitive material, e.g., a hot melt material, such as polypropylene, polyester or nylon, e.g. as available commercially from Engineered Yarn Company, of Fall River, Mass. The loop yarn **44** includes, or consists largely of, fibers of flame retardant material **46**. During heating of the fabric article of this embodiment, e.g. during dyeing and/or finishing, the hot melt material of the sheath fuses, thus increasing the tortuosity and further reducing the paths for passage of chilling wind through the fabric and improving the dynamic insulation performance of the fabric article **40** of the invention.

Referring now to FIG. **17**, in a fabric article **50** of the invention, the stitch yarn **52** includes elastomeric material **53**, e.g. such as spandex. The loop yarn **54** includes, or consists largely of, fibers of flame retardant material **56**. The elastomeric material **53** in the stitch yarn **52** also provides for relatively greater densification and tortuosity, and therefore increased dynamic insulation performance for enhanced protection from wind penetration, as well as providing for fabric stretch and enhanced wearer comfort.

Referring now to FIG. **18**, a fabric article **60** of the invention may also be formed of stitch yarns **62** including or consisting largely of combinations of heat sensitive materials **63** and elastomeric materials **65**. For example, stitch yarns employed in the fabric article **60** may include fibers or filaments of different characteristics that have been commingled or plaited together. The loop yarn **64** includes, or consists largely of, fibers of flame retardant materials **66**.

Referring to FIG. **19**, in another embodiment, a fabric article **70** of the invention is formed of loop yarns **72** of standard denier that, upon application of heat, e.g. during dyeing and/or finishing, split axially into multiple, elongated fibers or filaments. The result is a reduction or narrowing of paths for passage of chilling wind through the fabric, to increase tortuosity and dynamic insulation performance of the fabric article **70**. The loop yarns may be caused to split also by application, e.g., of a chemical treatment, e.g. caustic soda, or by application of a mechanical action, e.g. napping.

Referring finally to FIG. **20**, in yet another embodiment, a fabric article **80** of the invention is formed of loop yarns **82** having an "islands-in-sea" construction. Namely, the loop yarns **82** are formed of a hot melt polymeric body ("sea") containing multiple filaments ("islands") of small diameter, e.g. 0.01 to 0.03 denier. Upon application of heat to the fabric article **80**, e.g., during dyeing and/or finishing, the hot melt material melts to release the individual, small diameter filaments. Again, the release of the small filaments results in increased tortuosity and dynamic insulation performance of the fabric article **80**.

Alternatively, referring to FIG. **21**, in a different embodiment, a double face velour fabric article **90** of the invention is formed of very bulky filament stitch yarn **92** with relatively low shrinkage. The resulting fabric article **90** will be significantly heavier, less drapeable, and will have relatively poor stretch/recovery, e.g. as compared to the embodiments described above. However, the high bulk, high thickness of the raised surface regions **94**, **96** formed by finishing fibers of the loop yarn **93** of flame retardant

material **98** will provide enhanced protection or shielding of the stitch yarn **92** from excessive heat and thermal shrinkage, as well as from burning and melting.

Finally, referring to FIG. **22**, in yet another embodiment of the invention, a velour fabric article **101**, in this case having one or more raised or fleece surface regions **103** at only one surface, is formed with a plaiting circular knit construction from a loop yarn **105**, e.g. including, or consisting largely of, flame retardant material **107**, such as m-Aramide fibers (NOMEX®) of 1.5 denier, and a filament stitch yarn **108**, e.g. including, or consisting largely of, thermoplastic filament yarn **110**, formed of materials such as polyester, nylon, or polypropylene, commingled or plaited with spandex material **112**, such as LYCRA® (also available from E. I. du Pont). The fibers of the loop yarn **104** are finished at the technical back **114** to create a velour or fleece region **103** at one surface. The fabric article **101** of this embodiment has good stretch, when tested according to ASTM 2594, in both length and width dimensions. The single face velour fabric **101** can be formed into articles for tight fit, which enhances the comfort and insulation performance in dynamic (windy) conditions. Positioning the fleece surface **103** of flame retardant material **107** against the wearer's skin also shields against potential drip of the thermoplastic stitch yarn material **110** onto the skin, e.g. in a fire condition. Positioning of the flame retardant surface region **103** against the skin also improves thermal insulation (in cold weather), as well as providing enhanced thermal insulation, as measured on a Frazier air permeability unit in accordance with ASTM D-737. It also shields against penetration of material from melting fibers of the stitch yarn **108** through to burn the wearer's skin.

Due to the increased tortuosity, including after heat treatment, a fabric article of the invention formed with stitch yarns including or consisting largely of heat sensitive materials and/or elastomeric materials, such as spandex, and/or loop yarns formed of heat sensitive materials and/or elastomeric materials such as spandex, and/or cored yarns having a sheath of hot melt material, have enhanced dynamic insulation performance, e.g. as compared to a prior art fabric article **100** (FIG. **3**) having the same weight. As a result, the fabric articles of the invention are particularly suited for use, e.g., in lightweight clothing and the like for use in extreme conditions of chilling wind and cold temperature.

Examples of fabric articles of the invention formed with heat sensitive materials and/or elastomeric materials will now be described. The air permeability was tested according to ASTM D-737 (the complete disclosure of which is incorporated herein by reference) on a Frazier machine with $\frac{1}{2}$ of water pressure drop.

EXAMPLE 1

A fabric article of the invention, designated S/7380, was formed of a stitch yarn consisting of 150/34 POWER-STRETCH™ heat shrinkable textured polyester, available from UNIFI, Inc., and a loop yarn consisting of 150/132 textured polyester. After exposure to heat, the air permeability of the finished fabric article was 70 ft³/ft²/min.

EXAMPLE 2

Another fabric article of the invention, designated E555P, was formed of a stitch yarn consisting of 50/36 textured polyester with 20 denier spandex on every other end plaited with the 50/36 textured polyester and a loop yarn consisting of 150/132 textured polyester. After exposure to heat, the air permeability of the finished fabric article was 59 ft³/ft²/min.

11

EXAMPLE 3

Yet another fabric article of the invention, designated E657Y, was formed of a stitch yarn consisting of 50/36 textured polyester commingled with 40/20 textured polypropylene and a loop yarn consisting of 100/96 textured polyester. After exposure to heat, the air permeability of the finished fabric article was 38-40 ft³/ft²/min.

EXAMPLE 4

Another fabric article of the invention, designated E667Q, was formed of a stitch yarn consisting of 100/34 POWER-STRETCH™ heat shrinkable textured polyester and a loop yarn consisting of 100/96 textured polyester. After exposure to heat, the air permeability of the finished fabric article was 60-70 ft³/ft²/min.

A number of embodiments of the invention have been described. Nevertheless, it will be understood that various modifications may be made without departing from the spirit and scope of the invention. For example, any suitable type of yarn may be employed. Also, other suitable methods of constructing a velour fabric article of the invention may be employed. For example, in the preferred embodiment described above, the construction provided by reverse plaiting is employed in order to expose the loop yarn **16** for finishing at both surfaces of the fabric body, with segments **22** of the loop yarn **16** overlaying the stitch yarn **14** at the technical face **18** and formed into loops **23** at the technical back **20**. This is preferred, for reasons of dynamic insulation performance, over a construction in which only the loop yarn is finished. However, where improvement of dynamic insulation performance is not the primary or an overwhelming consideration, a construction exposing the stitch yarn and the loop yarn side by side for finishing at one or both surfaces of a fabric body may be preferred. In embodiments of fabric articles of the invention formed with heat sensitive materials, heat may be applied other than or in addition to during dyeing and/or finishing, e.g., before, after, or between these stages of manufacture. Also, referring again to FIG. **13**, a double-face velour fabric article **40** of the invention may be formed by applying the hydroentanglement process to the technical face **18** and/or the technical back **20**, e.g., using fine, high-pressure water jets **32** and/or **32'**, respectively.

As mentioned above, a fabric article with stitch yarn and/or loop yarn comprising heat sensitive and/or elastomeric material may also be entangled or hydroentangled according to the invention.

Accordingly, other embodiments are within the scope of the following claims.

What is claimed is:

1. A velour fabric article comprises a fabric body having a technical face formed by a filament stitch yarn and a technical back formed by a loop yarn, said filament stitch yarn comprising heat sensitive material and said loop yarn comprising flame retardant material selected from the group consisting of: m-Aramide fibers, m-Aramide fiber and p-Aramide fiber blends, and fibers and fiber blends of inherent flame retardant materials, said fabric body having a velour surface formed at one or both of said technical back and said technical face, and said heat sensitive material responding to application of heat during processing to increase tortuosity with a result of said fabric body having permeability of about 90 ft³/ft²/min or less under a pressure difference of ½ inch of water across the fabric body.

2. The velour fabric article of claim **1**, wherein said heat sensitive material comprises hot melt material.

12

3. The velour fabric article of claim **1**, wherein said heat sensitive material comprises heat shrinkable material.

4. The velour fabric article of claim **1**, wherein said heat sensitive material is selected from the group consisting of polypropylene, nylon, and polyester.

5. The velour fabric article of claim **1**, claim **2**, claim **3**, or claim **4**, wherein said heat sensitive material responds to application of dry heat.

6. The velour fabric article of claim **1**, claim **2**, claim **3**, or claim **4**, wherein said heat sensitive material responds to application of wet heat.

7. The velour fabric article of claim **6**, wherein said heat sensitive material responds to application of wet heat applied by steam.

8. The velour fabric article of claim **6**, wherein said heat sensitive material responds to application of wet heat applied by hot water.

9. The velour fabric article of claim **1**, claim **2**, claim **3**, or claim **4**, wherein said heat sensitive material responds to application of heat of about 212° F. to about 450° F. applied for about 2 minutes to about 60 minutes.

10. The velour fabric article of claim **1**, claim **2**, claim **3**, or claim **4**, wherein said filament stitch yarn comprises elastomeric material.

11. The velour fabric article of claim **10**, wherein said elastomeric material comprises spandex.

12. The velour fabric article of claim **10**, wherein filaments of said heat sensitive material and filaments of said elastomeric material are commingled together.

13. The velour fabric article of claim **10**, wherein filaments of said heat sensitive material and filaments of said elastomeric material are plaited together.

14. The velour fabric article of claim **10**, wherein raised fibers of the velour surface of at least one of the technical face and the technical back is entangled, including in and/or through interstices of the fabric body toward the other of the technical face and the technical back.

15. The velour fabric article of claim **14**, wherein raised fiber of the technical back are entangled, including in and/or through interstices of the fabric body, toward the technical face.

16. The velour fabric article of claim **1**, claim **2**, claim **3**, or claim **4**, wherein said filament stitch yarn is a cored yarn comprising a core and a sheath, said sheath comprising hot melt material.

17. The velour fabric article of claim **16**, wherein said hot melt material is selected from the group consisting of polypropylene, polyester and polyamide.

18. The velour fabric article of claim **16**, wherein said core comprises a material selected from the group consisting of polyester and nylon.

19. The velour fabric article of claim **1**, wherein said loop yarn splits to release multiple small diameter filaments.

20. The velour fabric article of claim **19**, wherein said loop yarn splits by application of heat to release said multiple small diameter filaments.

21. The velour fabric article of claim **20**, wherein said loop yarn comprises an "islands-in-sea" construction.

22. The velour fabric article of claim **19**, wherein said loop yarn splits by application of a chemical treatment to release said multiple small diameter filaments.

23. The velour fabric article of claim **19**, wherein said loop yarn splits by application of a mechanical action to release said multiple small diameter filaments.

24. The velour fabric article of claim **1**, wherein said loop yarn is textured.

25. The velour fabric article of claim **1**, wherein said stitch yarn is textured.

13

26. The velour fabric article of claim 1, claim 2, claim 3, or claim 4, wherein raised fibers of the velour surface of at least one of the technical face and the technical back is entangled, including in and/or through interstices of the fabric body toward the other of the technical face and the technical back.

27. The velour fabric article of claim 26, wherein raised fiber of the technical back are entangled, including in and/or through interstices of the fabric body, toward the technical face.

28. The velour fabric article of claim 1, wherein said fabric body has a velour surface region formed at said technical back.

29. The velour fabric article of claim 1, wherein said fabric body has a velour surface region formed at each of said technical back and said technical face.

30. A velour fabric article comprises a fabric body having a technical face formed by a filament stitch yarn and a technical back formed by a loop yarn, said filament stitch yarn comprising elastomeric material and said loop yarn comprises flame retardant material selected from the group consisting of: m-Aramide fiber and p-Aramide fiber blends, and fibers and fiber blends of inherent flame retardant materials, said fabric body having a velour surface formed at one or both of said technical back and said technical face, and said fabric body having permeability of about 90 ft³/ft²/min or less under a pressure difference of ½ inch of water across the fabric body.

31. The velour fabric article of claim 30, wherein said elastomeric material comprises spandex.

32. The velour fabric article of claim 1 or claim 30, wherein said fabric body has permeability of about 70 ft³/ft²/min or less.

33. The velour fabric article of claim 30, wherein raised fibers of the velour surface of at least one of the technical face and the technical back is entangled, including in and/or

14

through interstices of the fabric body toward the other of the technical face and the technical back.

34. The velour fabric of claim 32, wherein raised fibers of the technical back are entangled, including in and/or through interstices of the fabric body, toward the technical face.

35. *A velour fabric article comprises a fabric body having a technical face formed by a filament stitch yarn and a technical back formed by a loop yarn, said filament stitch yarn comprising heat sensitive material and said fabric body comprising flame retardant material selected from the group consisting of: m-Aramide fibers, m-Aramide fiber and p-Aramide fiber blends, and fibers and fiber blends of inherent flame retardant materials, said fabric body having a velour surface formed at one or both of said technical back and said technical face, and said heat sensitive material responding to application of heat during processing to increase tortuosity and decreased permeability, thereby to improve dynamic insulation performance of the fabric article.*

36. *A velour fabric article comprises a fabric body having a technical face formed by a filament stitch yarn and a technical back formed by a loop yarn, said filament stitch yarn comprising heat sensitive material and said fabric body comprising flame retardant material selected from the group consisting of: m-Aramide fibers, m-Aramide fiber and p-Aramide fiber blends, and fibers and fiber blends of inherent flame retardant materials, said fabric body having a velour surface formed at one or both of said technical back and said technical face, and said heat sensitive material responding to application of heat during processing to increase tortuosity with a result of said fabric body having permeability of less than about 193 ft³/ft²/min under a pressure difference of ½ inch of water across the fabric body.*

* * * * *

UNITED STATES PATENT AND TRADEMARK OFFICE
CERTIFICATE OF CORRECTION

PATENT NO. : RE40,314 E
APPLICATION NO. : 11/635820
DATED : May 13, 2008
INVENTOR(S) : Rock et al.

Page 1 of 1

It is certified that error appears in the above-identified patent and that said Letters Patent is hereby corrected as shown below:

On the title page, Col. 2 Item (56) (Other Publications) delete “274133” and insert -- 2747133 --.

Col. 11, line 64, in Claim 1, delete “ft³/ft²min” and insert -- ft³/ft²/min --.

Col. 12, line 19, in Claim 9, after “of heat” delete “of” and insert -- at --.

Col 12, line 30, in Claim 13, before “said heat” delete “o” and insert -- of --.

Col. 13, line 25, in Claim 30, after “of:” insert -- m-Aramide fibers, --.

Col. 14, line 5, in Claim 34, after “fabric” insert -- article --.

Signed and Sealed this
Thirty-first Day of July, 2012



David J. Kappos
Director of the United States Patent and Trademark Office