



US00RE40270E

(19) **United States**
(12) **Reissued Patent**
Shiozaki et al.

(10) **Patent Number: US RE40,270 E**
(45) **Date of Reissued Patent: Apr. 29, 2008**

(54) **OPTICAL AMPLIFYING DEVICE**
(75) Inventors: **Toru Shiozaki**, Hyogo (JP); **Masaru Fuse**, Osaka (JP)
(73) Assignee: **Matsushita Electric Industrial Co., Ltd.**, Osaka (JP)
(21) Appl. No.: **11/014,665**
(22) Filed: **Dec. 17, 2004**

5,455,710 A 10/1995 Takeda
5,483,370 A * 1/1996 Takahashi 398/50

(Continued)

FOREIGN PATENT DOCUMENTS

JP 07199251 A * 8/1995
JP 9-130328 5/1997
JP 10-004231 1/1998
JP 10-51395 2/1998
JP 11-135862 5/1999
JP 11-205277 7/1999
JP 2002198599 A * 7/2002
JP 2002232048 A * 8/2002

Related U.S. Patent Documents

Reissue of:
(64) Patent No.: **6,496,304**
Issued: **Dec. 17, 2002**
Appl. No.: **10/075,618**
Filed: **Feb. 15, 2002**

OTHER PUBLICATIONS

Karasek, M. et al. "Effectiveness of gain control in EDFAs against traffic with different levels of bursty behavior" IEE Proc. Optoelectronics, 147:5, Oct. 2000, pp. 355-362.

Primary Examiner—Deandra M Hughes

(74) *Attorney, Agent, or Firm*—Wenderoth, Lind & Ponack, L.L.P.

U.S. Applications:
(62) Division of application No. 09/773,613, filed on Feb. 2, 2001, now Pat. No. 6,437,908.

(30) **Foreign Application Priority Data**

Feb. 3, 2000 (JP) 2000-26806
Apr. 20, 2000 (JP) 2000-118987

(57) **ABSTRACT**

An optical brancher branches an input optical signal into two. An optical detector converts one optical signal branched by the optical brancher into an electrical signal. A first controller generates a control electrical signal having a waveform obtained by inverting the envelope of the electrical signal. Based on the control electrical signal, an optical signal generator produces a dummy optical signal having a waveform λd and an amplitude $\alpha/2$. The other signal branched by the optical brancher is delayed by a delay unit for a predetermined time, and then multiplexed by an optical multiplexer with the dummy optical signal from the optical signal generator. An optical amplifier amplifies a multiplexed optical signal. An optical filter separates an optical signal of a wavelength $\lambda 1$ from the amplified optical signal. Thus, optical signal amplification can be carried out without optical surges.

(51) **Int. Cl.**
H04B 10/12 (2006.01)
H01S 3/00 (2006.01)
G01N 21/01 (2006.01)
G02B 21/34 (2006.01)

(52) **U.S. Cl.** **359/341.43; 359/337.11; 398/147**

(58) **Field of Classification Search** 398/31, 398/147; 359/337.1, 161, 337.11, 341.43
See application file for complete search history.

(56) **References Cited**

U.S. PATENT DOCUMENTS

5,396,360 A 3/1995 Majima

25 Claims, 20 Drawing Sheets

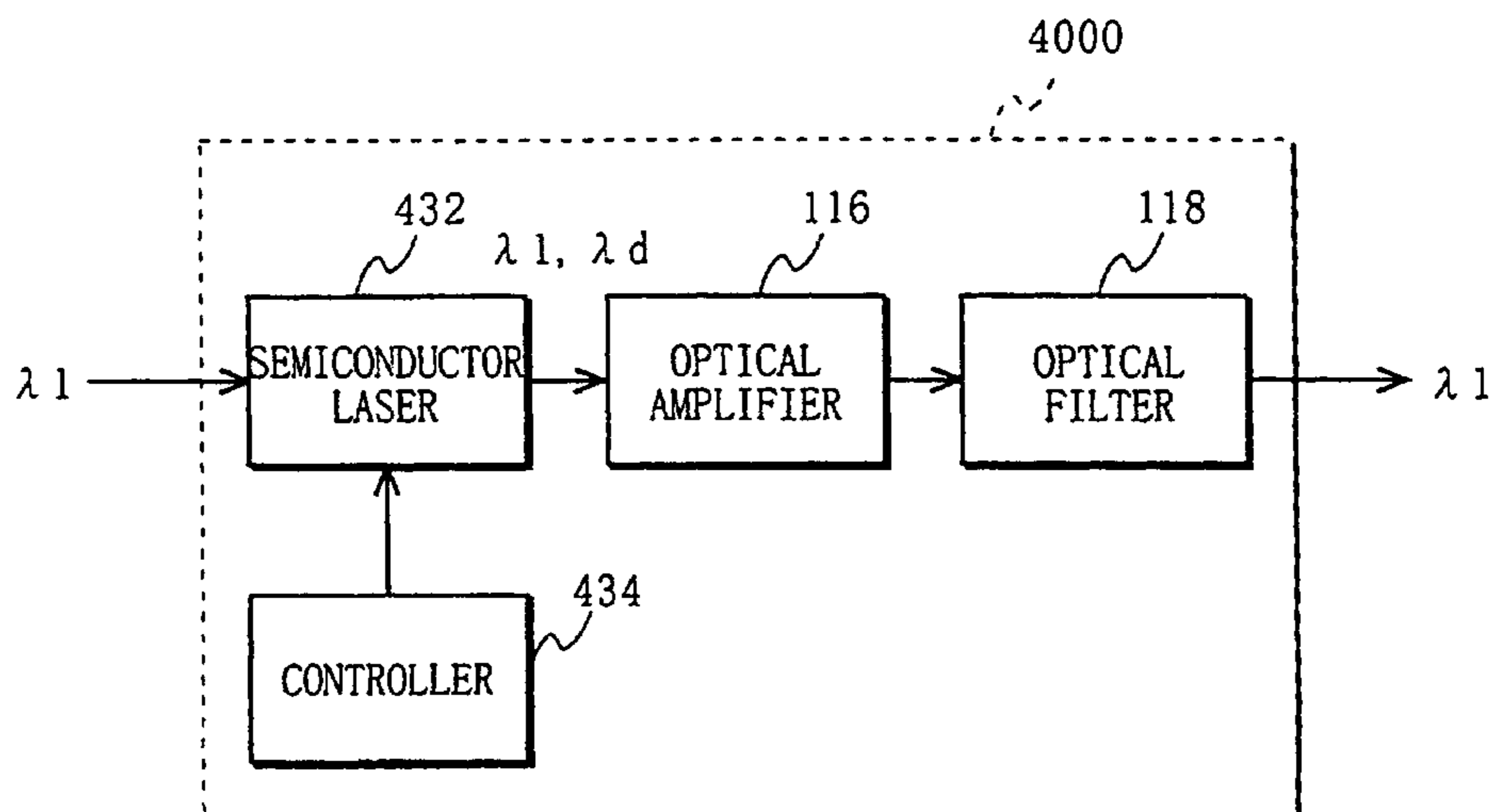

US RE40,270 E

Page 2

U.S. PATENT DOCUMENTS					
5,563,731 A	10/1996	Asahi	6,069,732 A *	5/2000	Koch et al. 359/344
5,570,227 A	10/1996	Nabeyama et al.	6,078,422 A	6/2000	Kosaka et al.
5,633,749 A	5/1997	Shibuya	6,229,643 B1	5/2001	Nakamura
5,675,428 A *	10/1997	Henmi 398/150	6,233,385 B1	5/2001	Taneda et al.
5,701,195 A	12/1997	Chikama	6,373,610 B1	4/2002	Takehana et al.
5,864,422 A	1/1999	Miyazaki et al.	6,426,817 B1 *	7/2002	Tomita 398/82
5,892,616 A	4/1999	Takahashi	6,486,991 B1 *	11/2002	Uehara 398/97
6,064,514 A	5/2000	Aoki et al.	2001/0033406 A1 *	10/2001	Koike et al. 359/152

* cited by examiner

FIG. 1

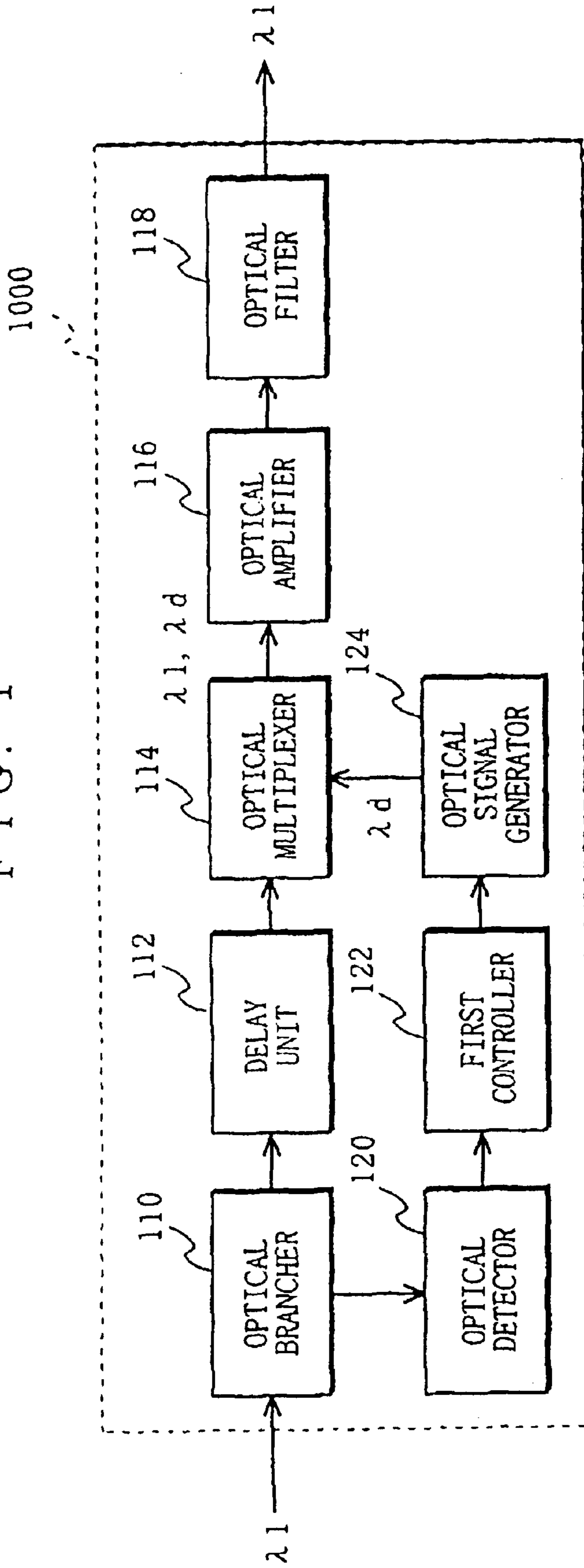

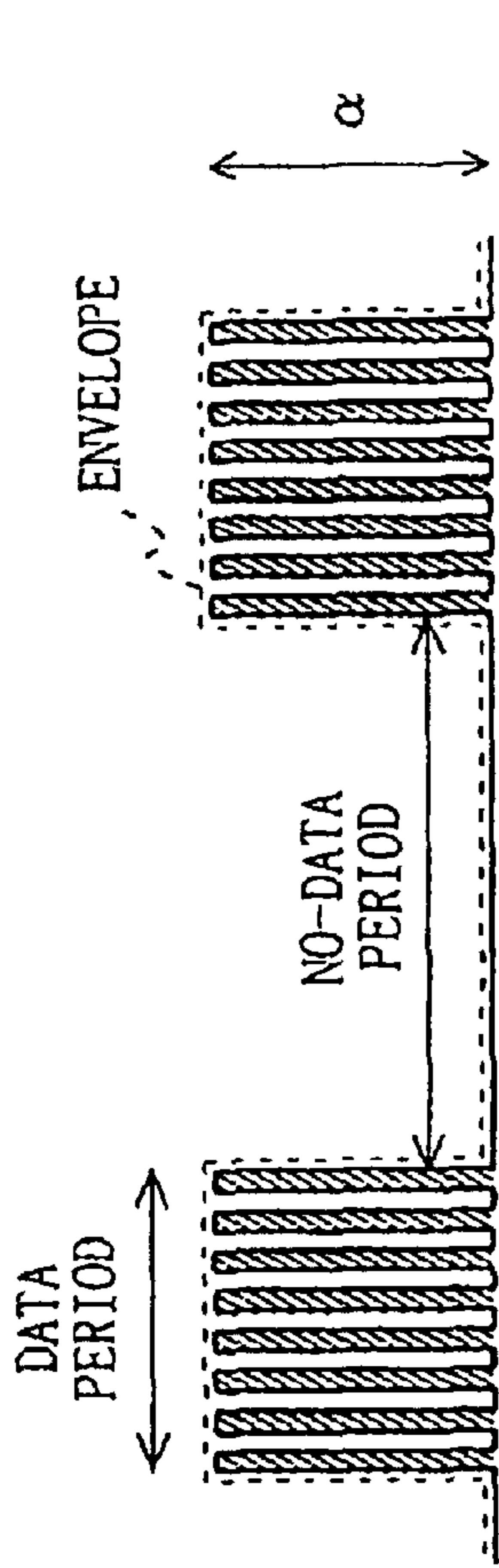

FIG. 2 a

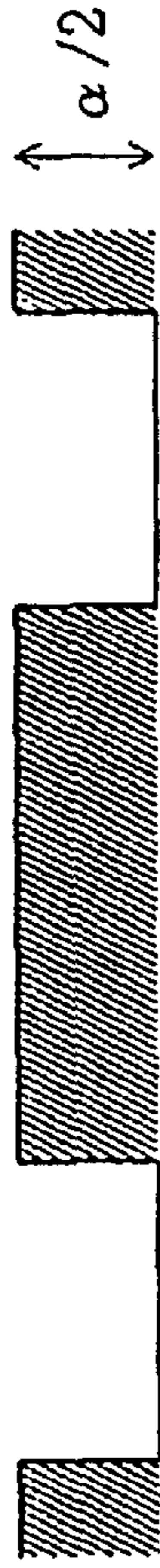

FIG. 2 b

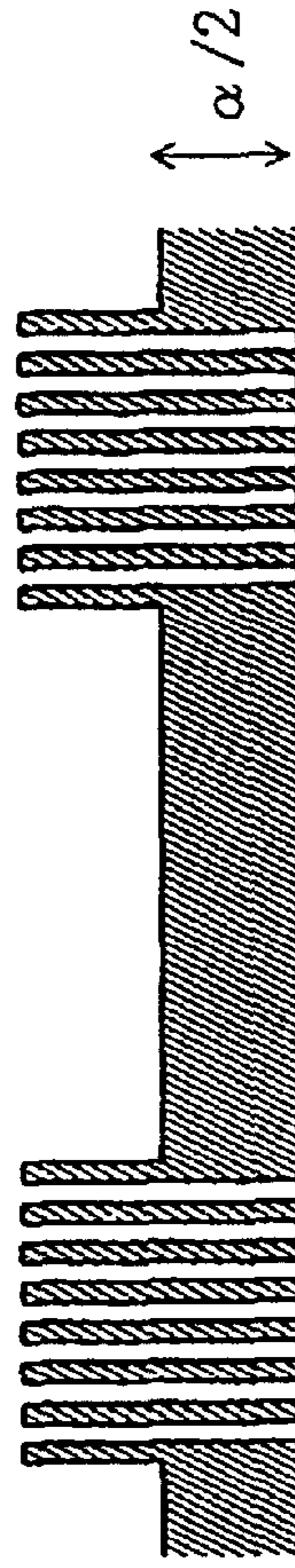

FIG. 2 c



FIG. 2 d

FIG. 3 a

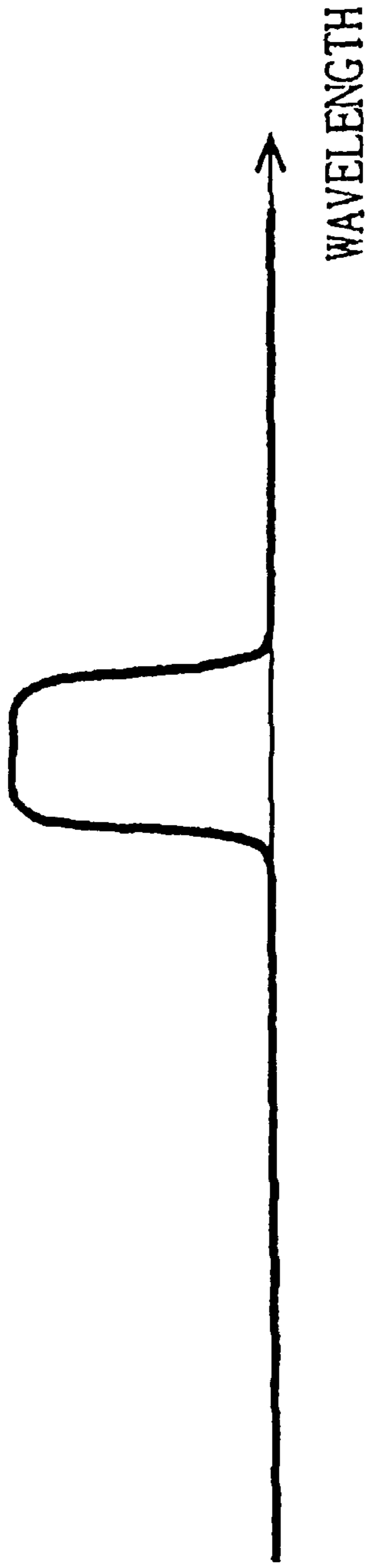

FIG. 3 b

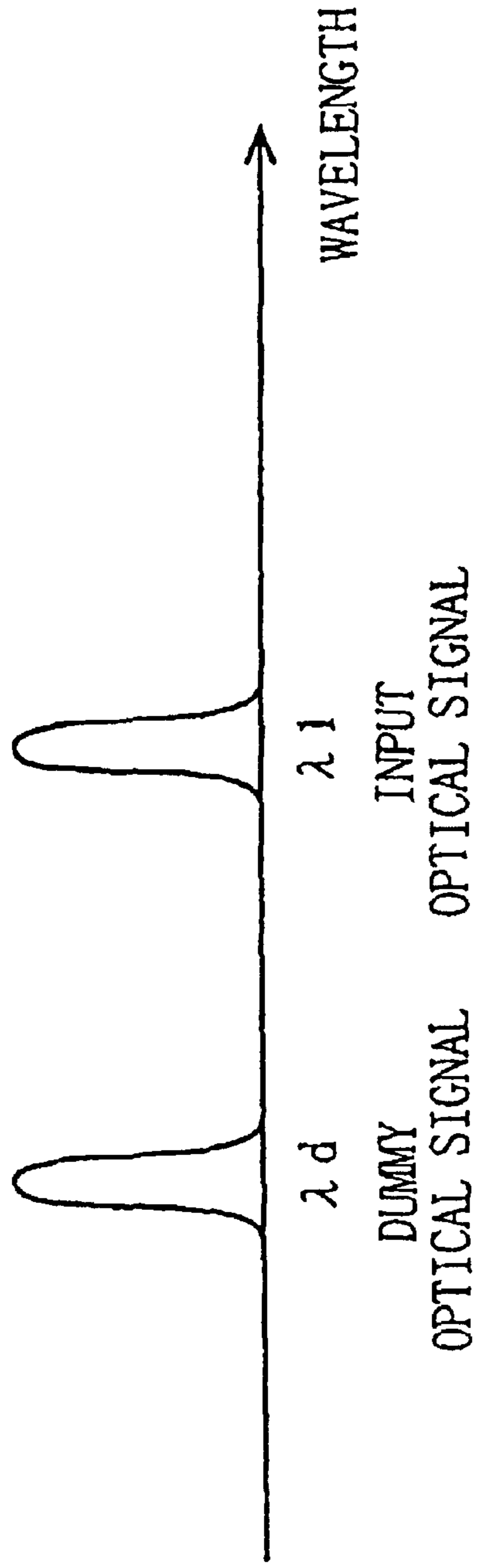

FIG. 4

1500

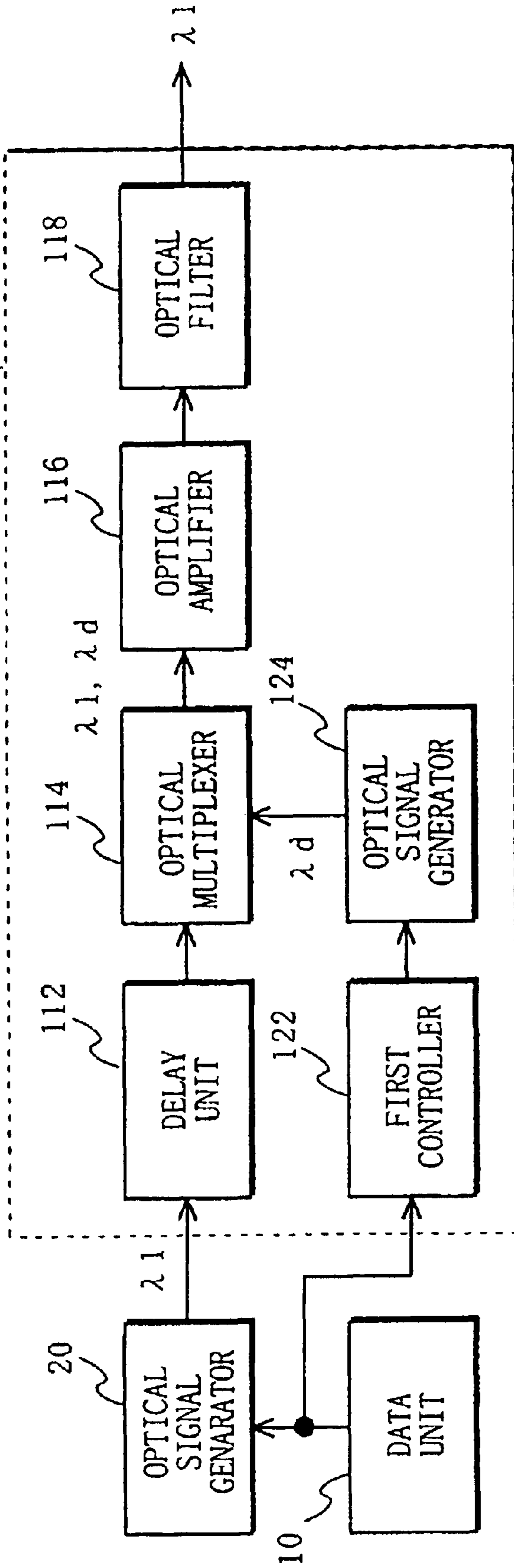
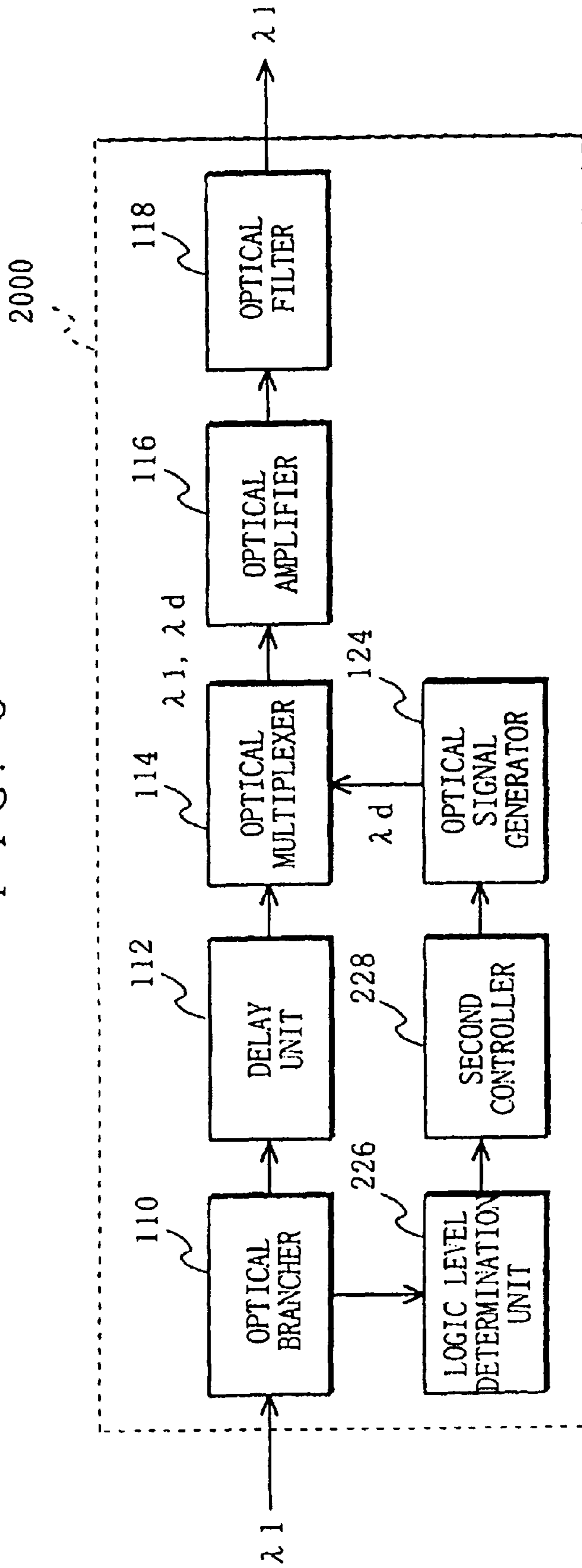

FIG. 5



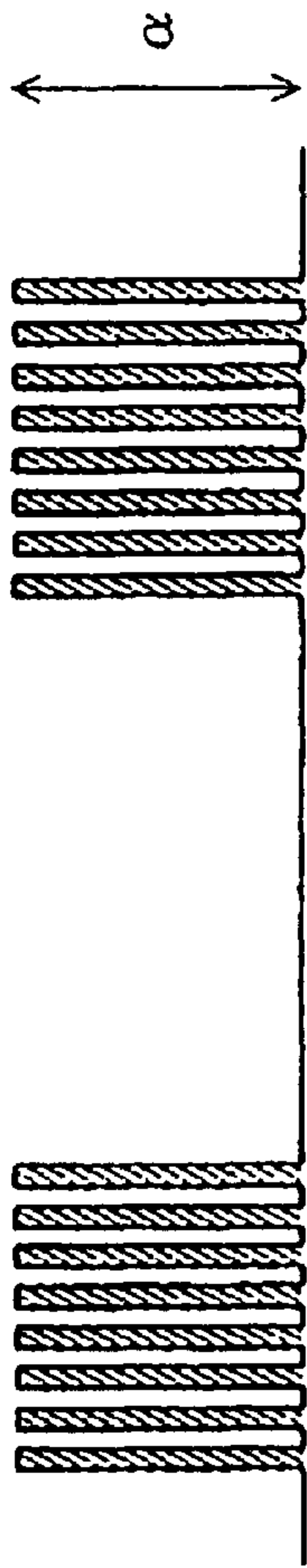

FIG. 6 a

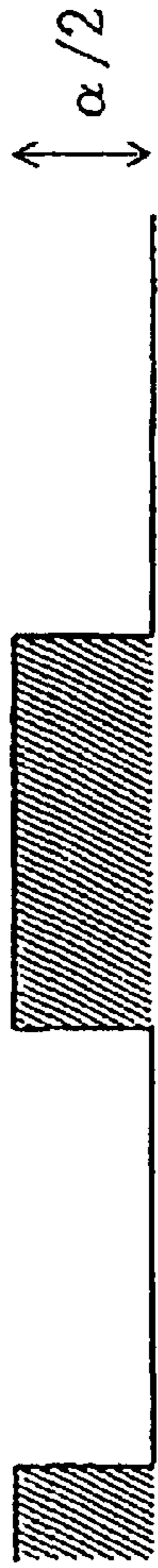

FIG. 6 b

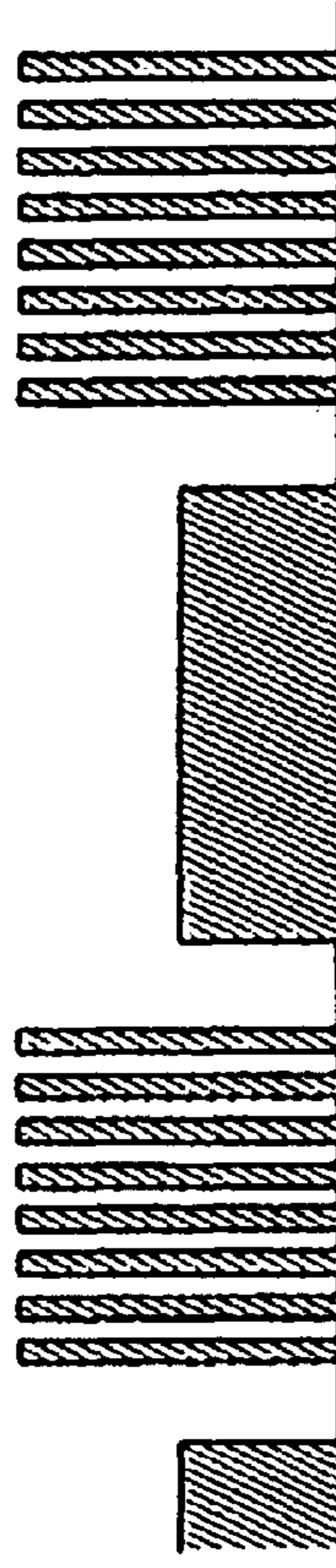
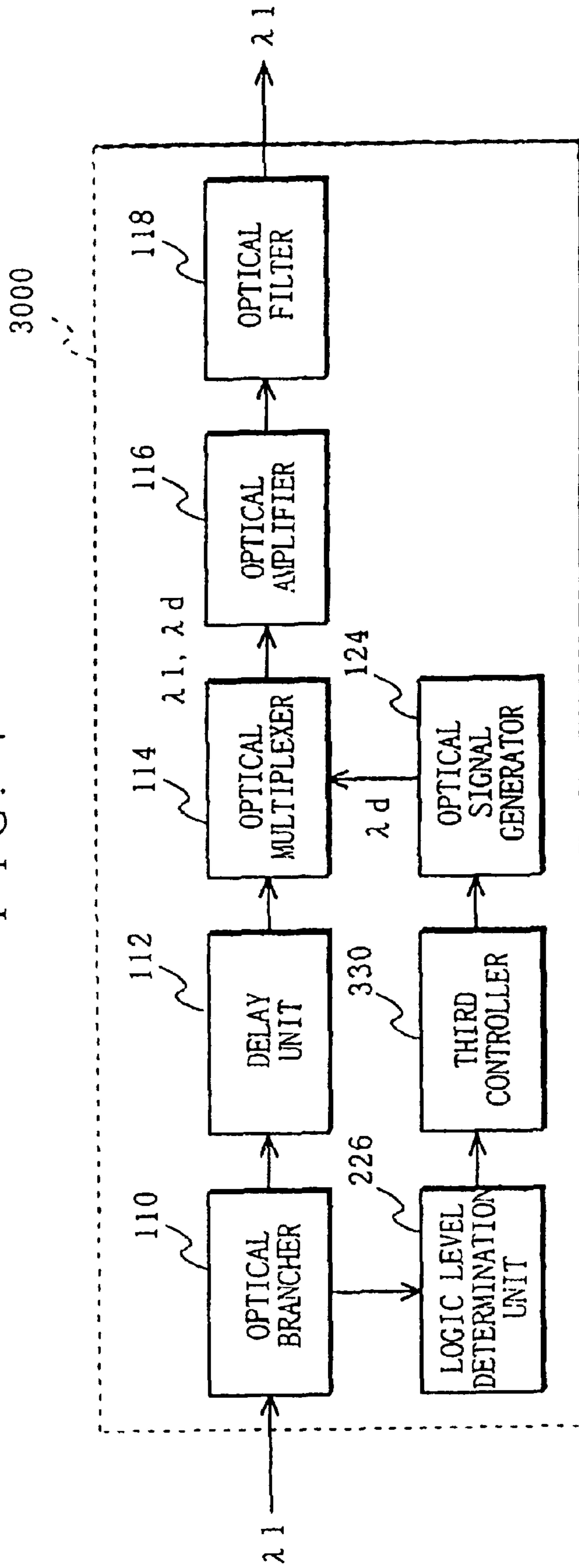

FIG. 6 c



FIG. 6 d

FIG. 7



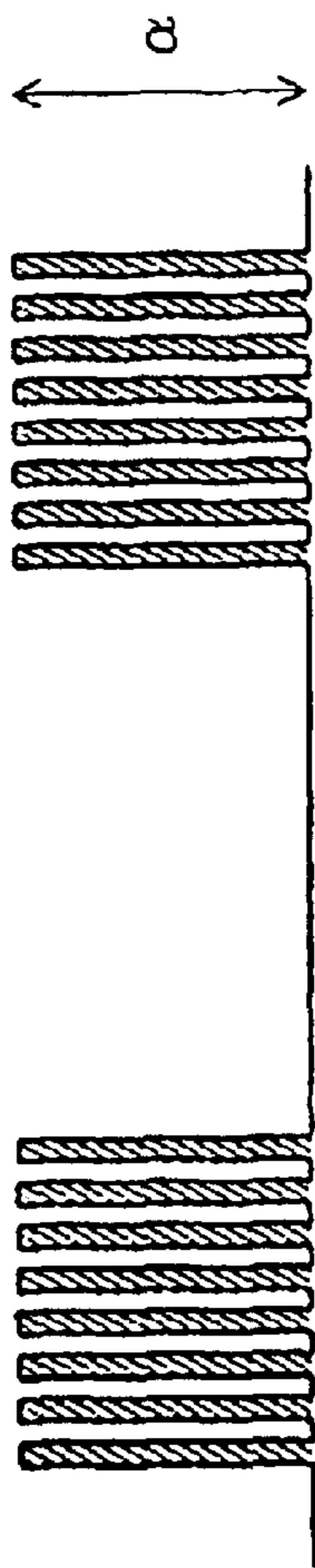

FIG. 8 a

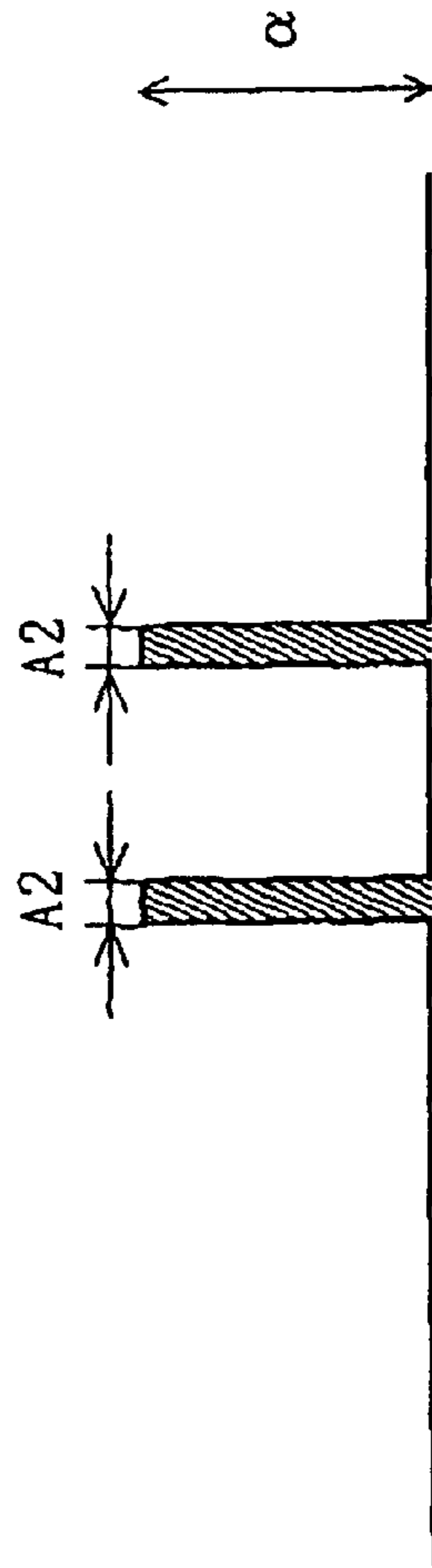

FIG. 8 b

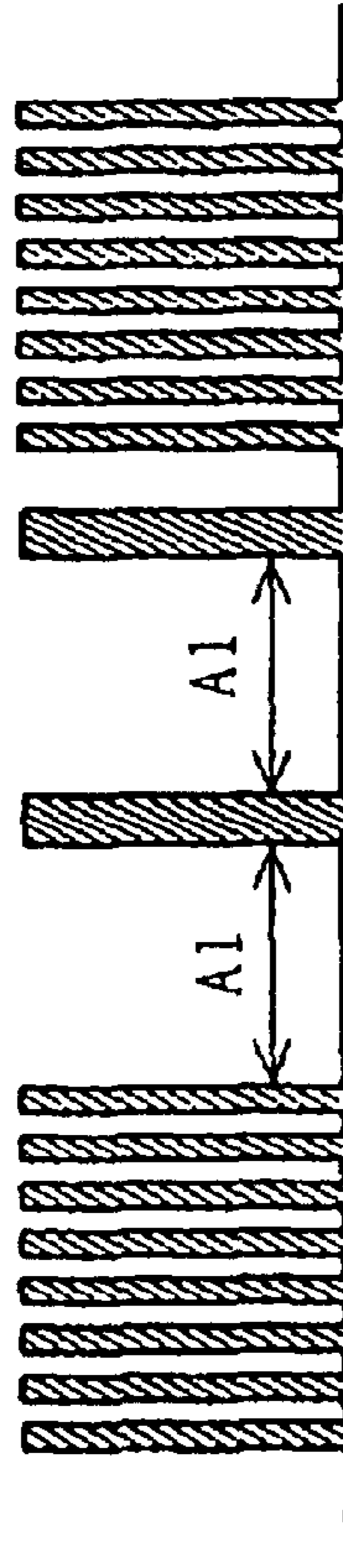

FIG. 8 c



FIG. 8 d

FIG. 9

4000

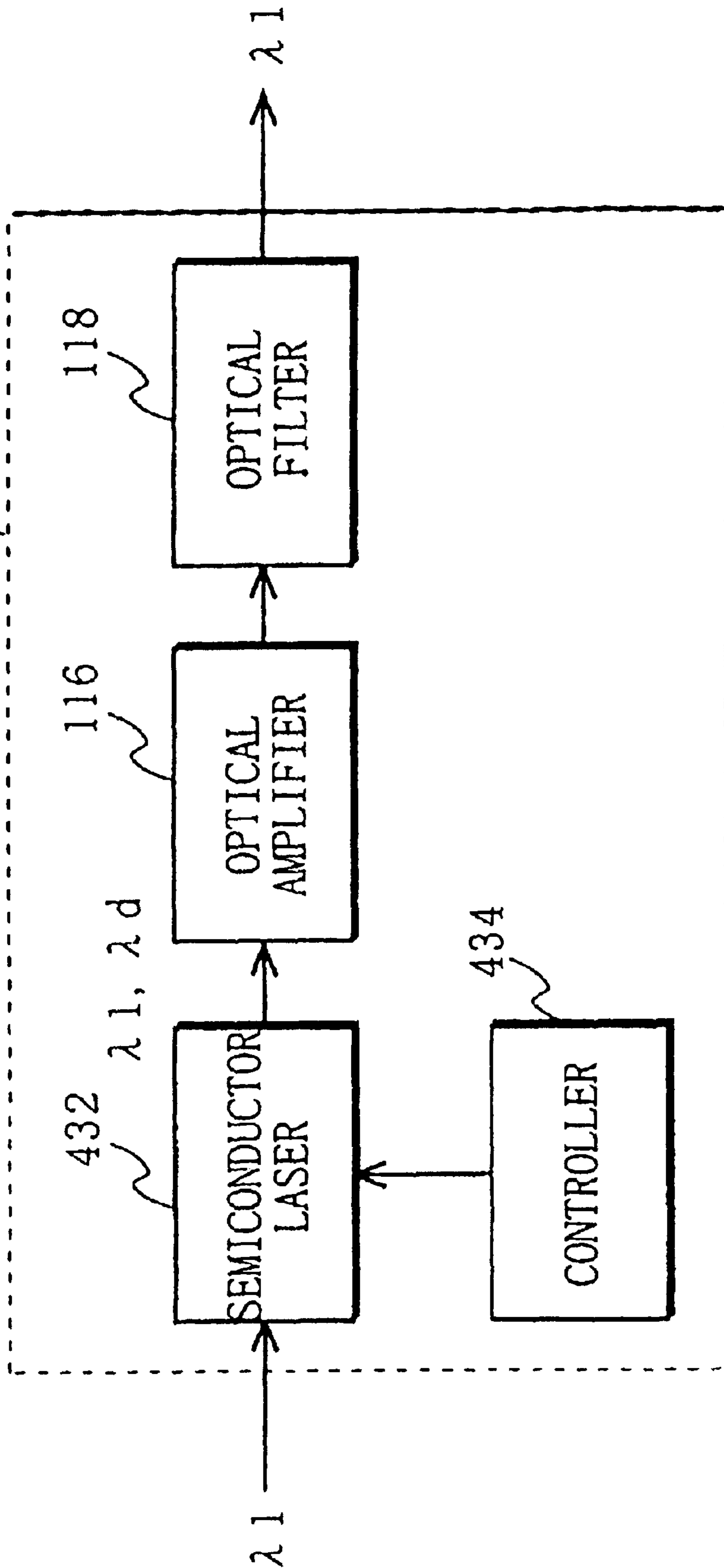

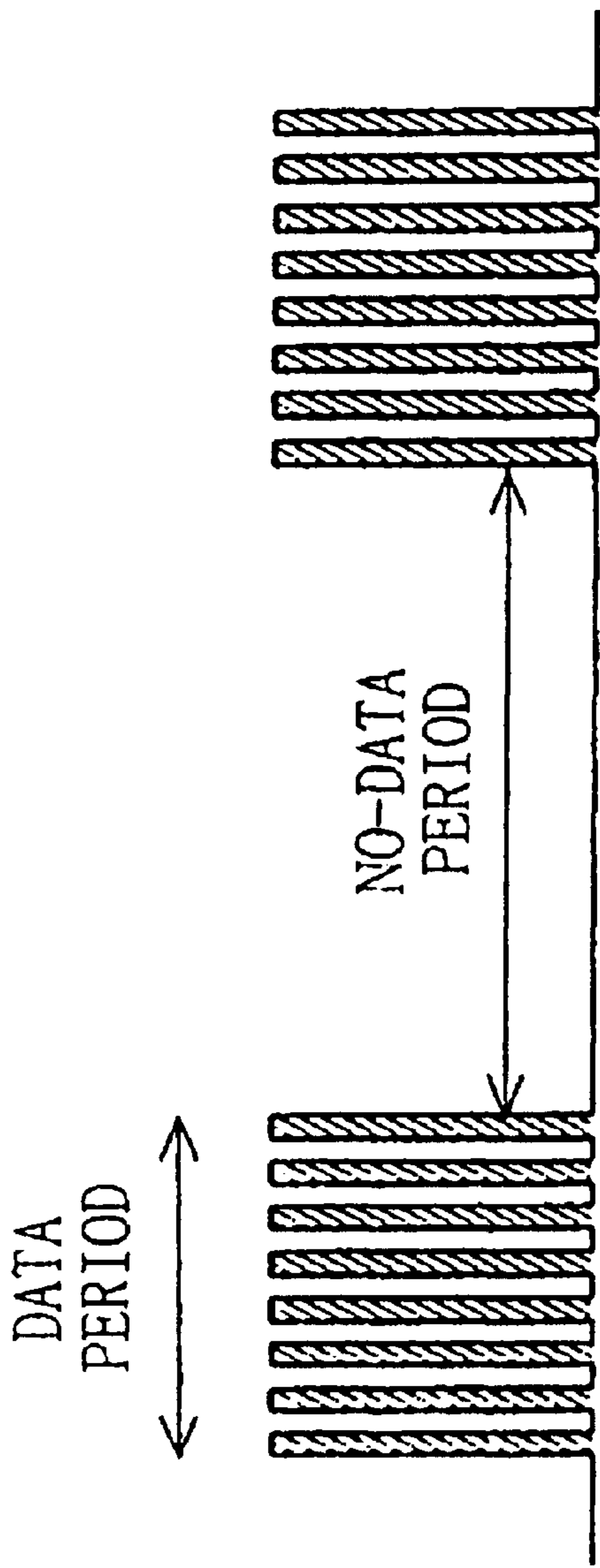

FIG. 10 a

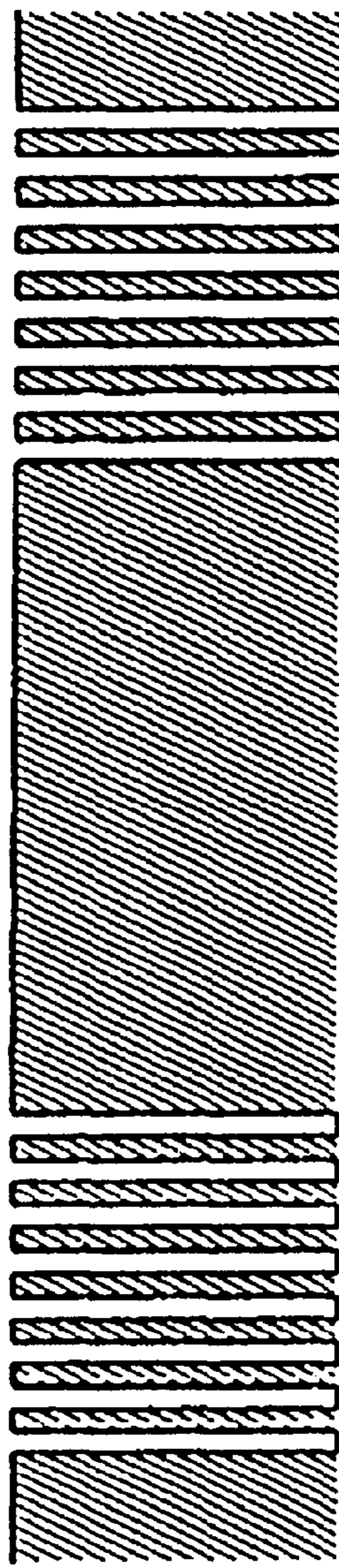
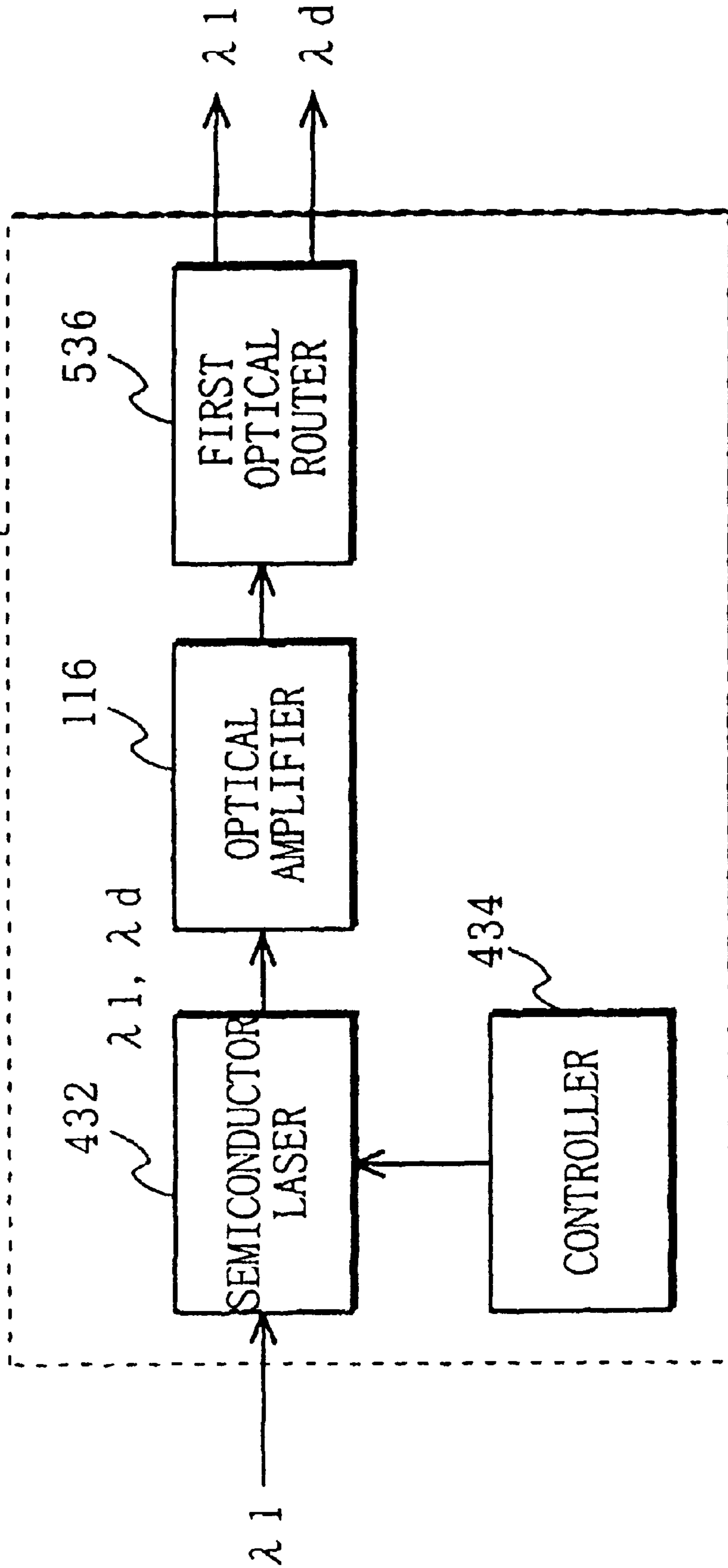

FIG. 10 b

FIG. 11

5000



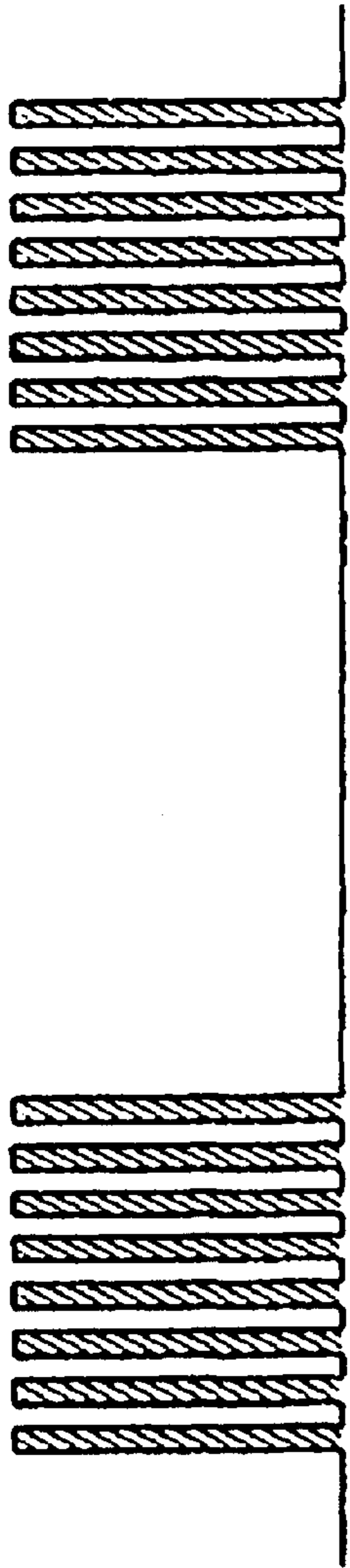

FIG. 12 a

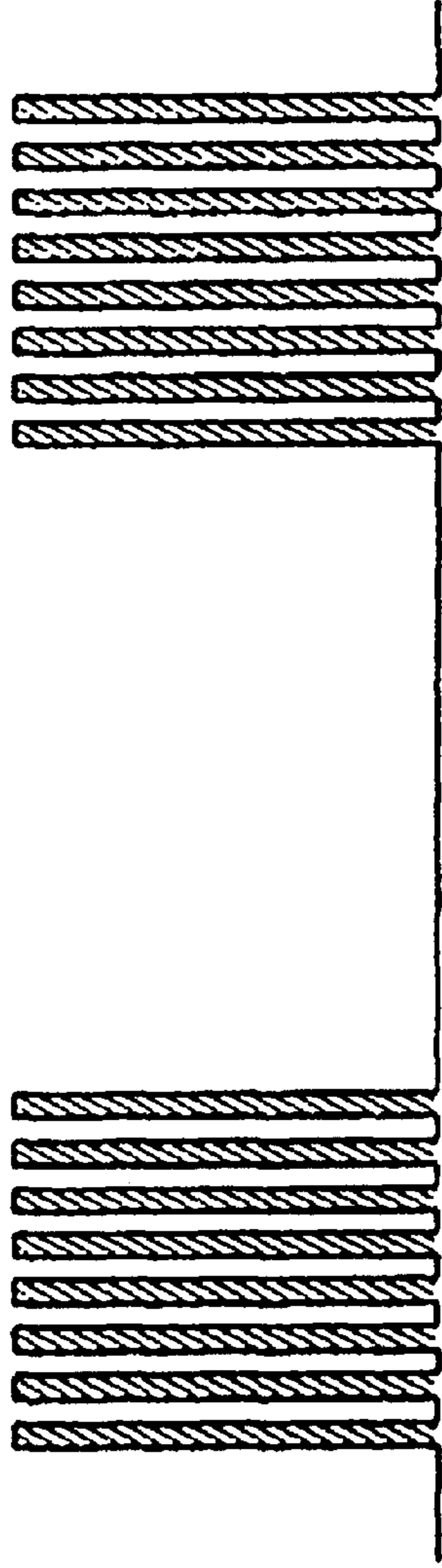

FIG. 12 b

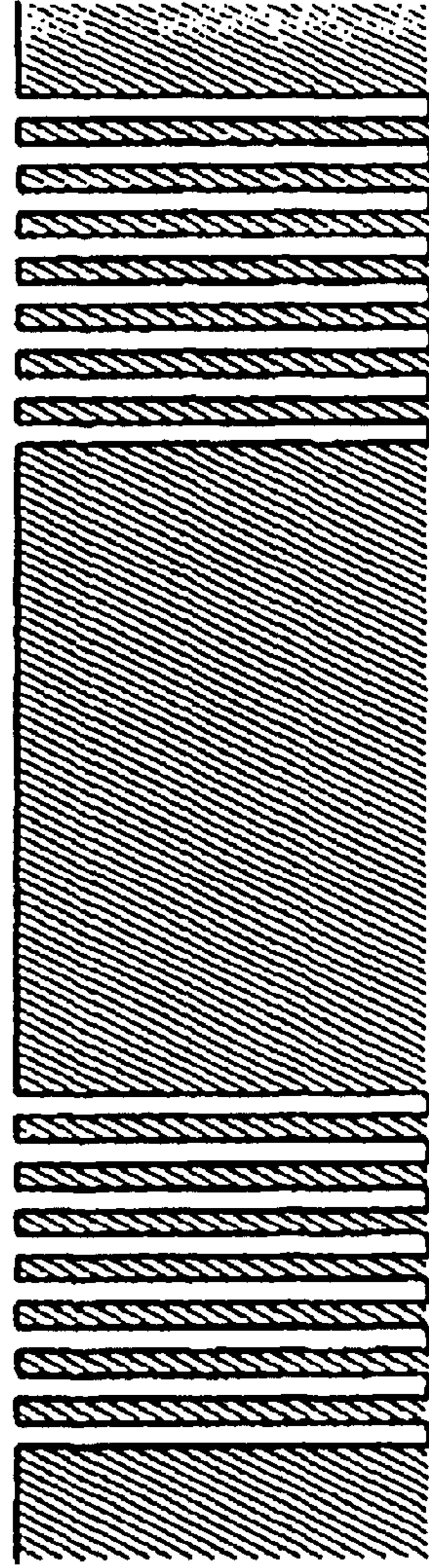

FIG. 12 c

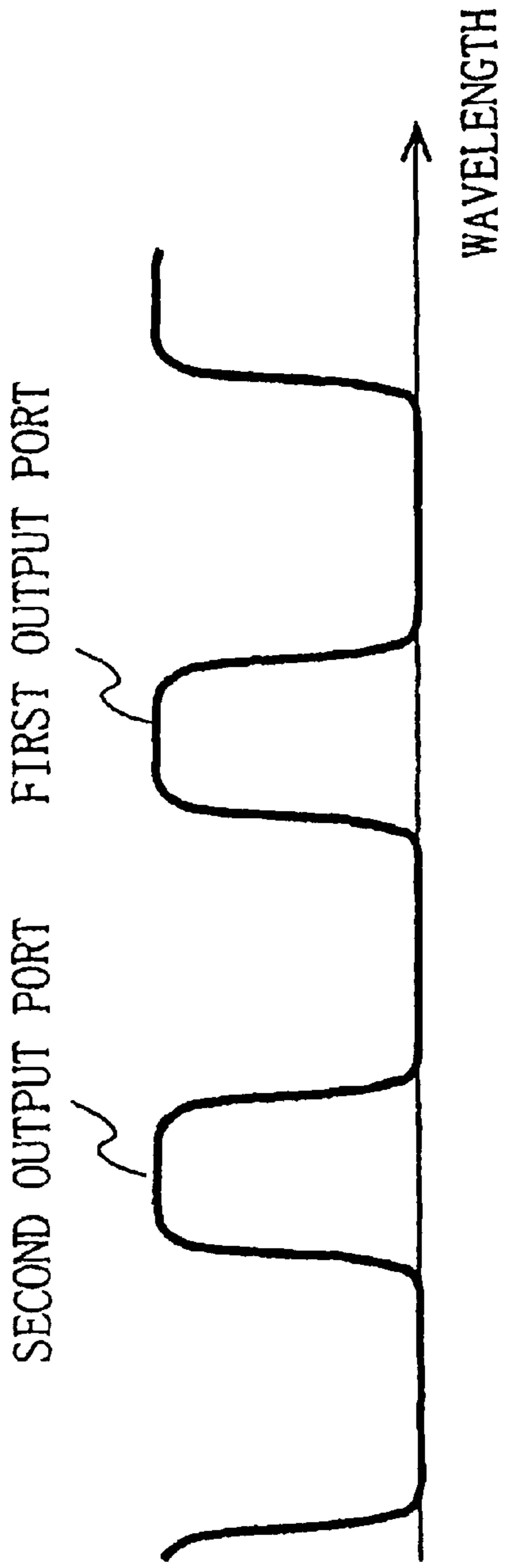

FIG. 13 a

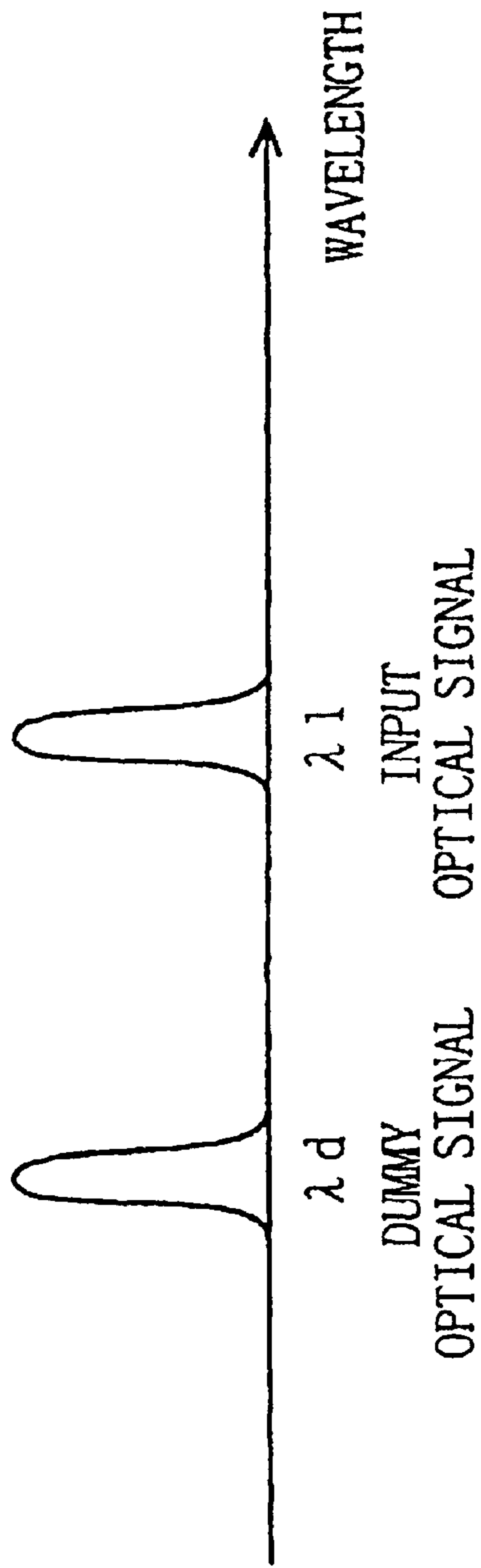

FIG. 13 b

FIG. 14

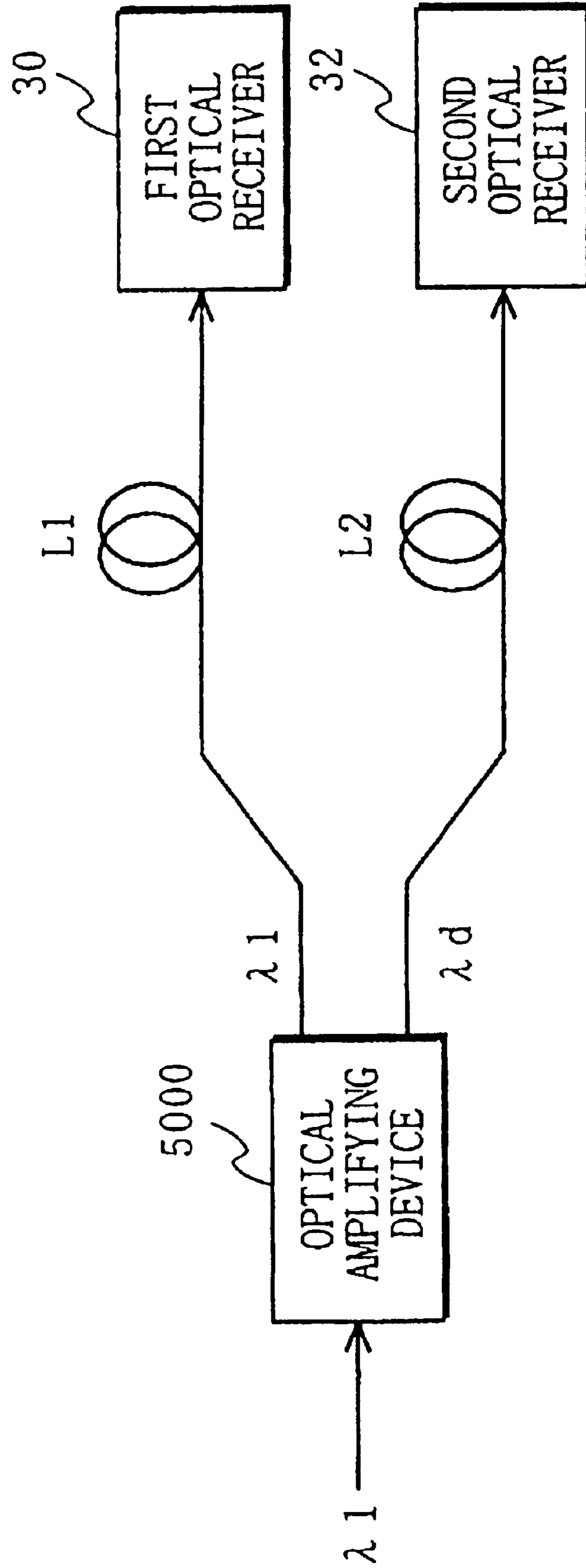

FIG. 15

6000

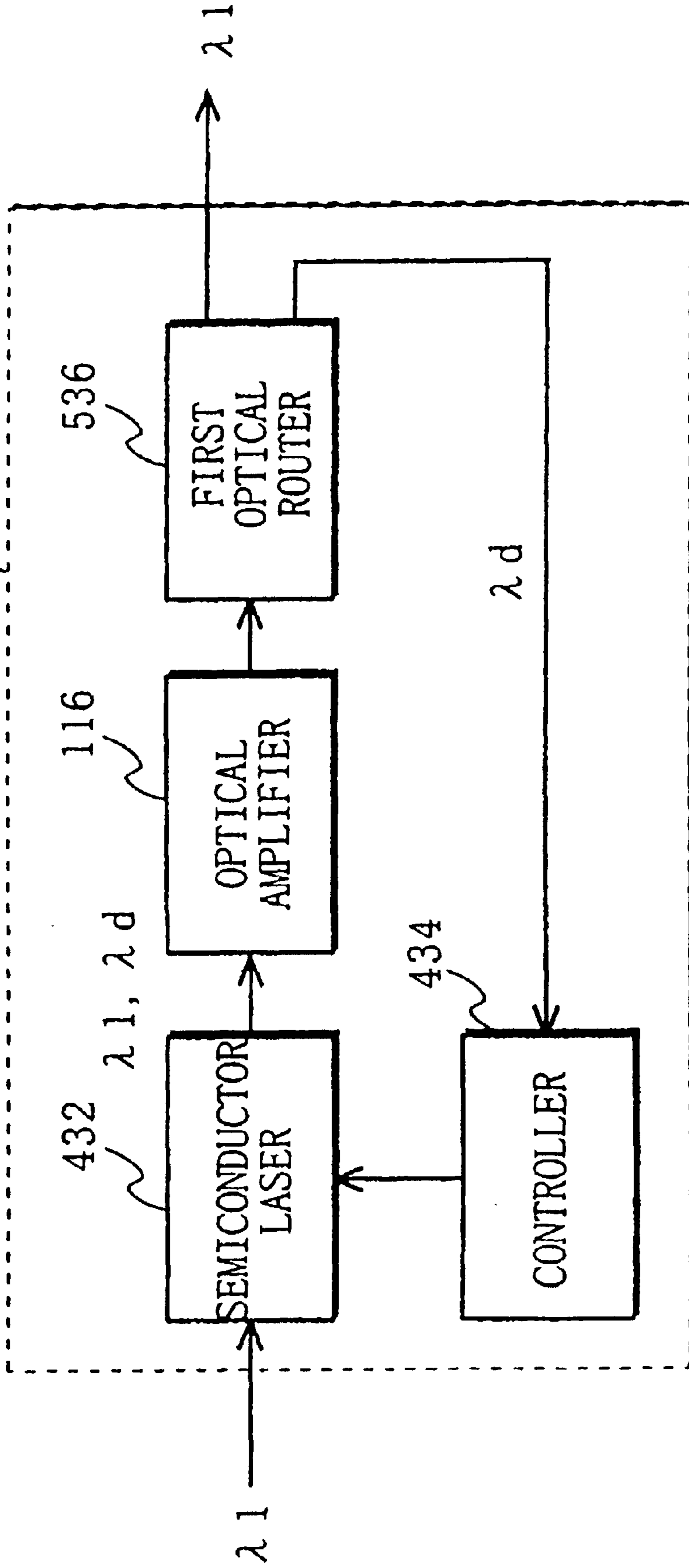
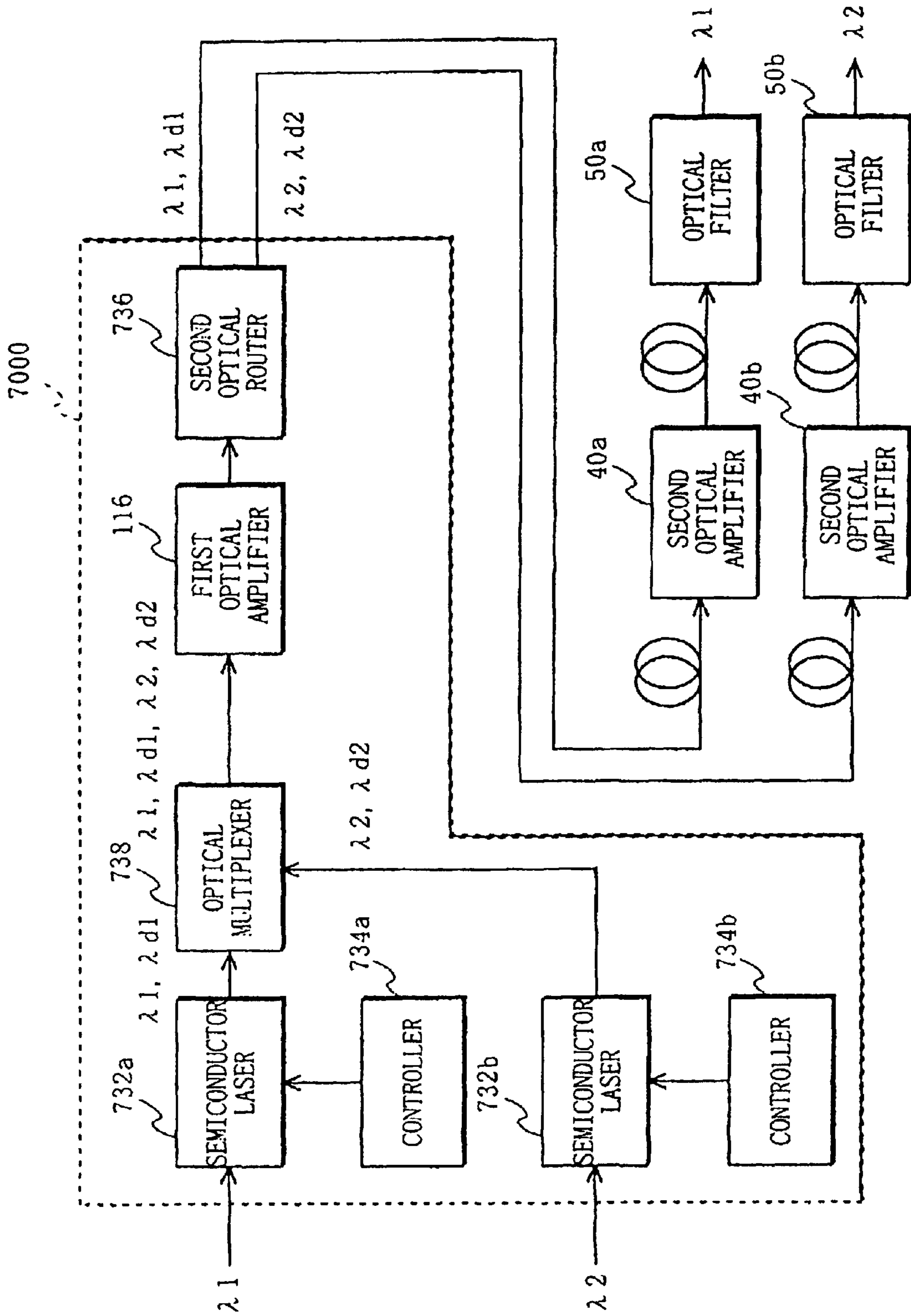

FIG. 16



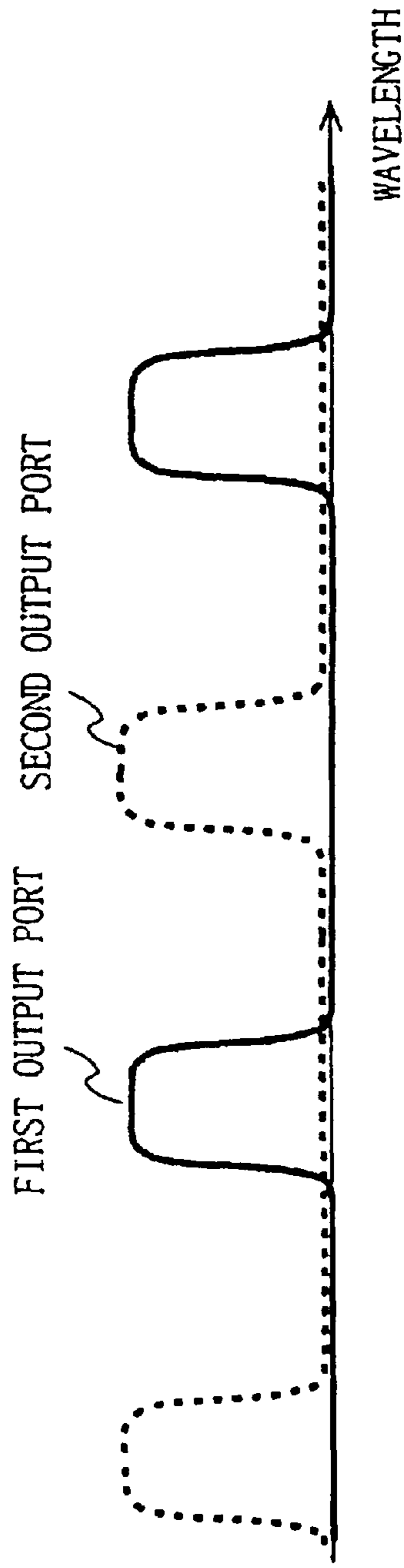

FIG. 17 a

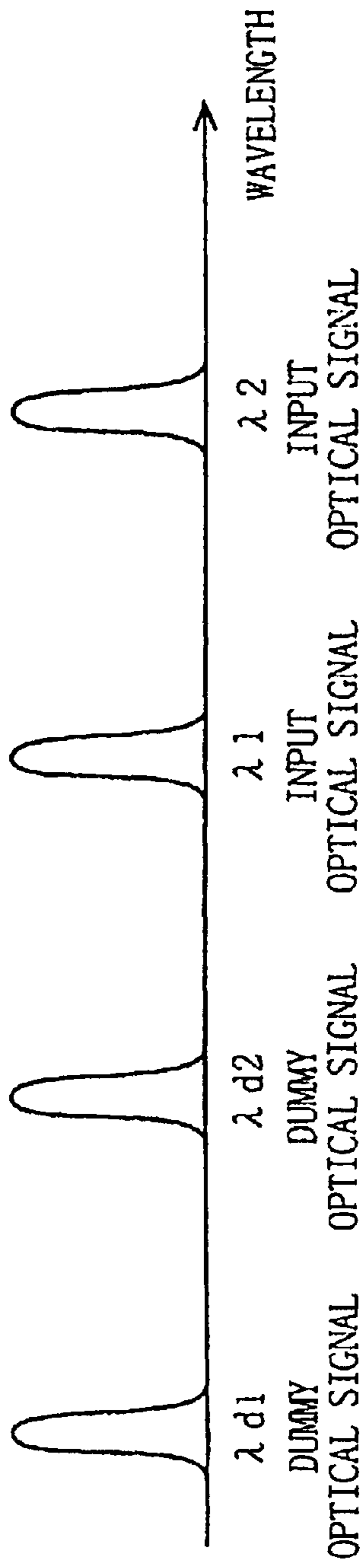

FIG. 17 b

FIG. 18b PRIOR ART

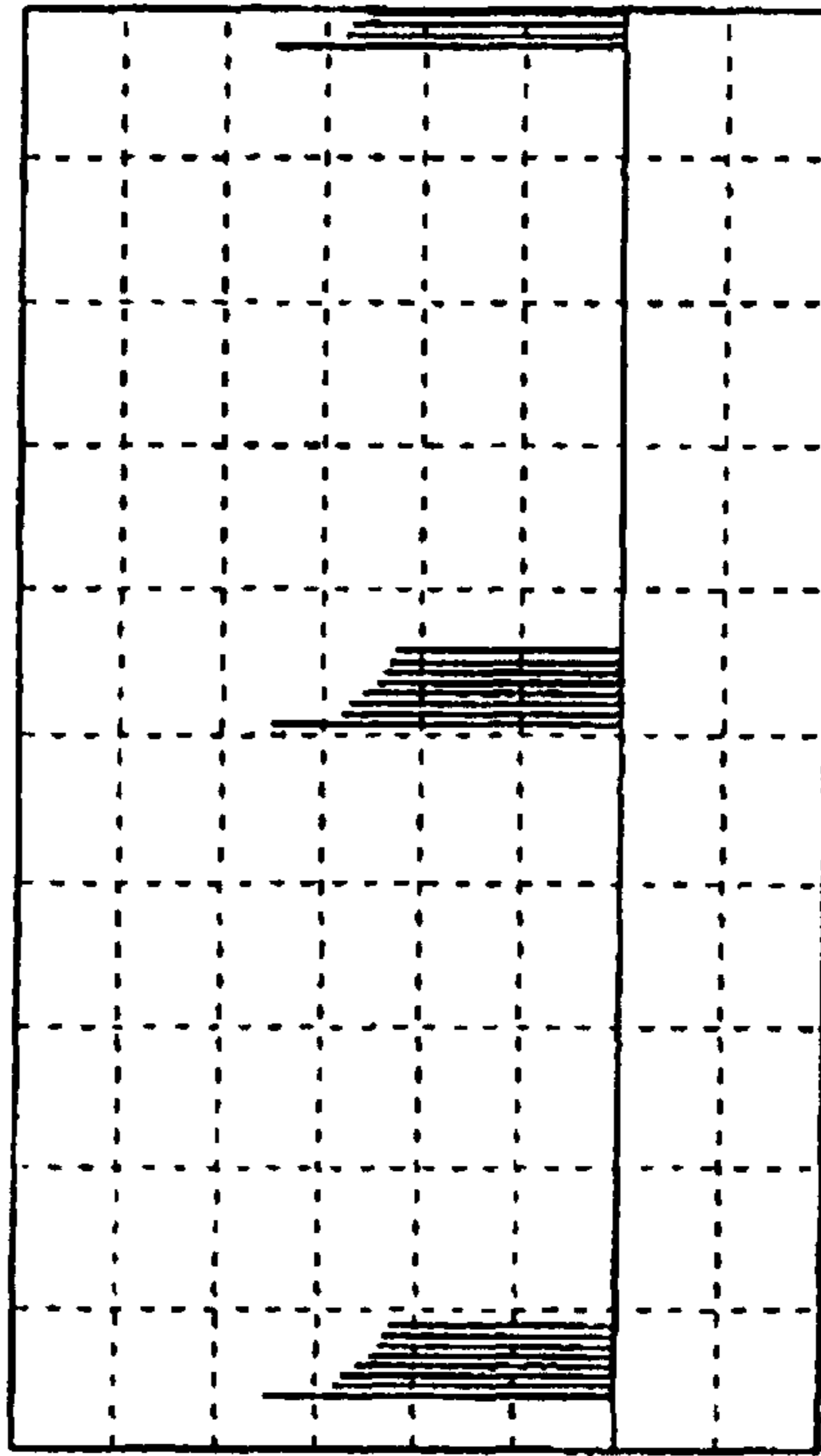

FIG. 18a PRIOR ART

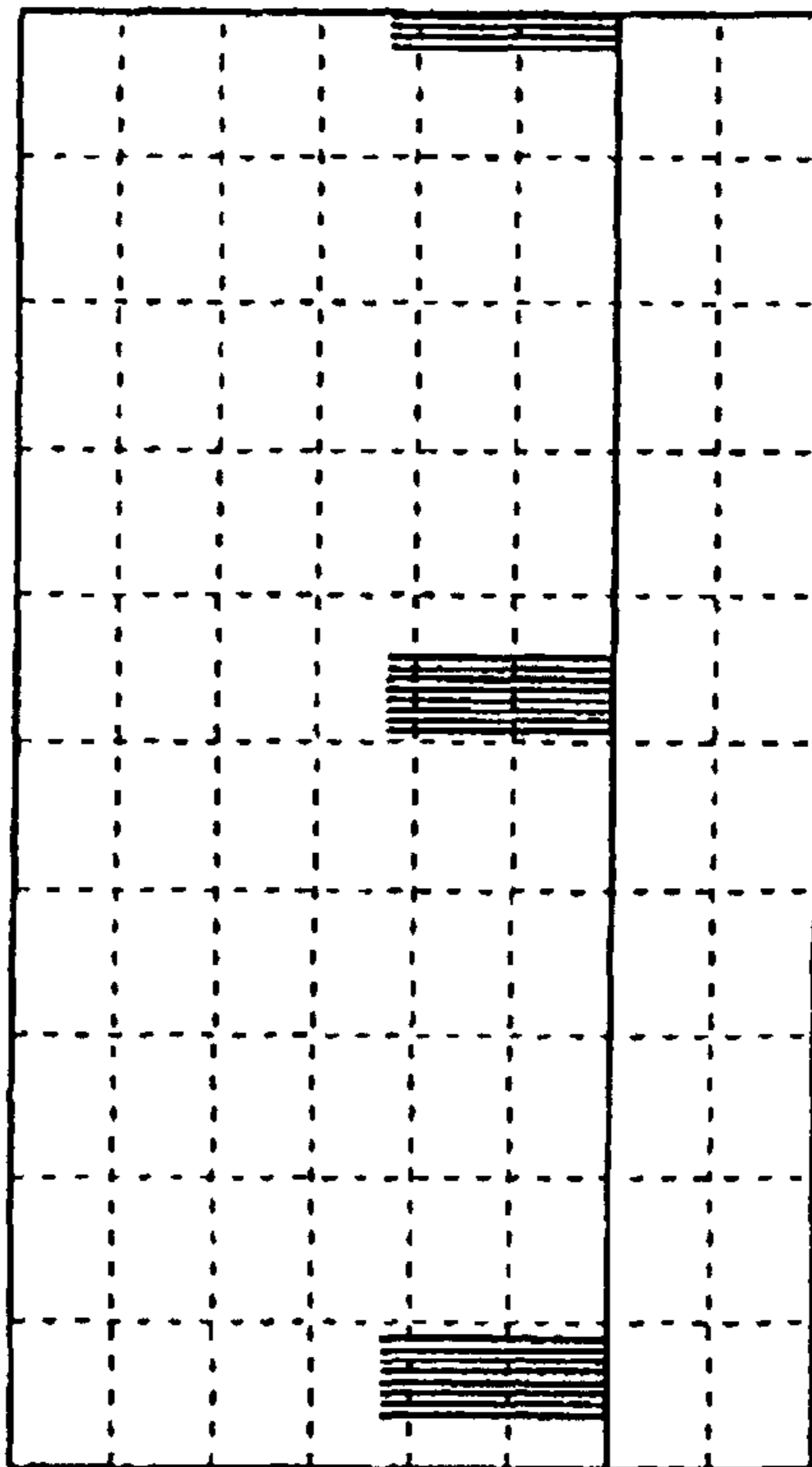
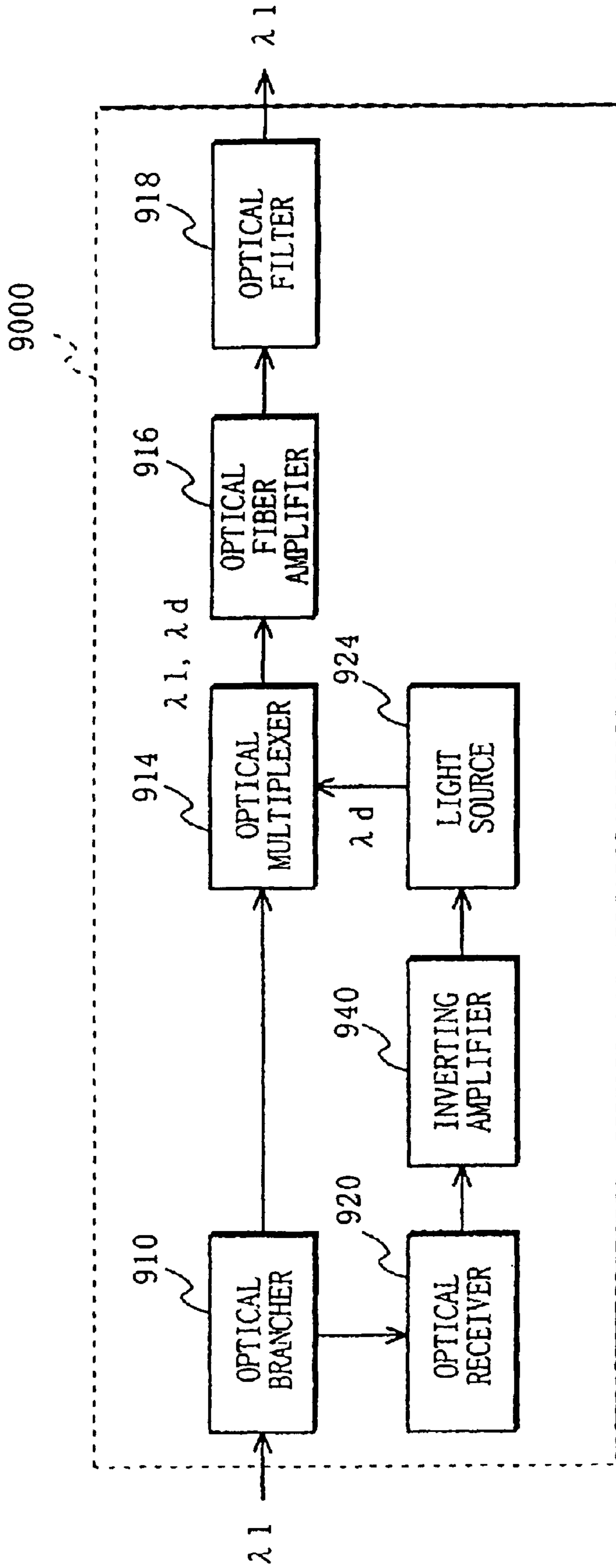

FIG. 19 PRIOR ART



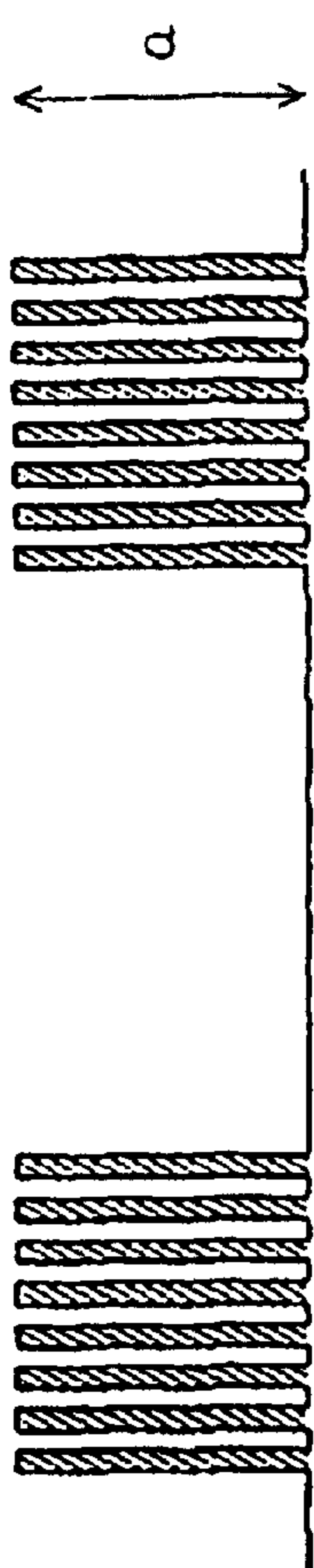

FIG. 20a PRIOR ART

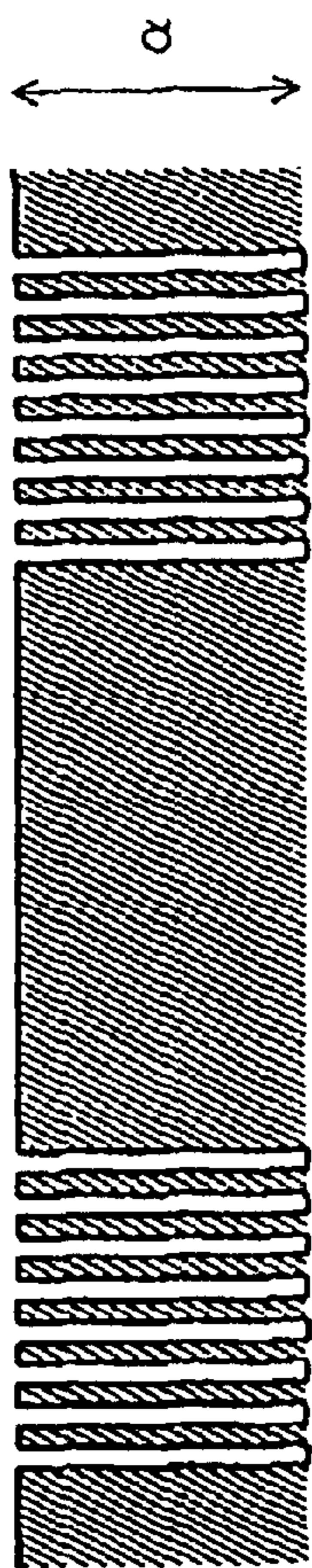

FIG. 20b PRIOR ART

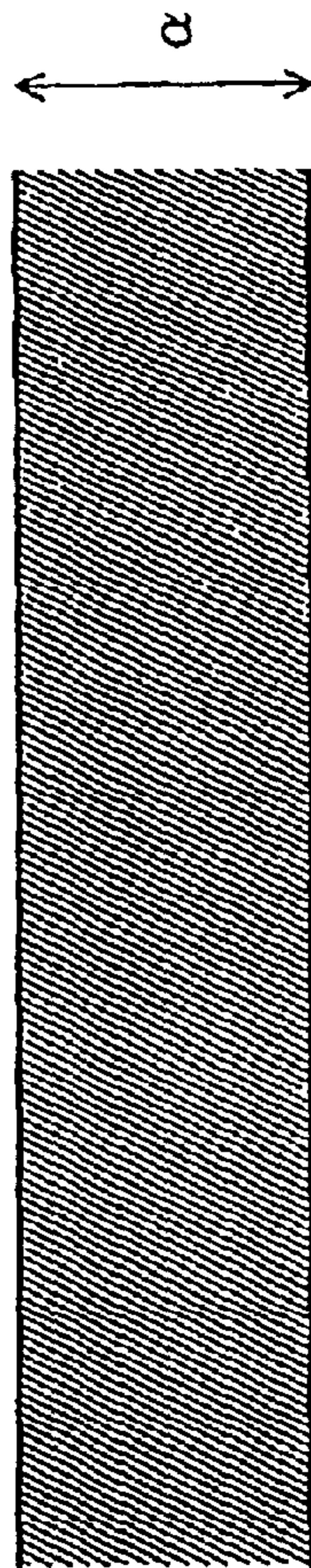

FIG. 20c PRIOR ART

OPTICAL AMPLIFYING DEVICE

Matter enclosed in heavy brackets [] appears in the original patent but forms no part of this reissue specification; matter printed in italics indicates the additions made by reissue.

This is a Divisional application of Ser. No. 09/773,613, filed Feb. 2, 2001, now U.S. Pat. No. 6,437,908.

BACKGROUND OF THE INVENTION

1. Field of the Invention

The present invention relates to optical amplifying devices for amplifying an input optical signal and, more specifically, to an optical amplifying device suitable for use in amplifying a burst optical signal.

2. Description of the Background Art

As well known, when intermittently-inputted optical signals (hereinafter referred to as burst optical signals) are amplified through a general optical fiber amplifier, for example, waveform degradation, called optical surges, occurs in the optical signals. Optical surges are now briefly described with reference to the accompanying drawings.

Optical surges are caused by transient response of optical amplifiers. How much the input optical signal is degraded in a waveform depends on the characteristics of the optical amplifier, such as a relaxation time constant. Waveform degradation also depends on the input optical signal itself. As the input light varies in power, the waveform becomes degraded.

FIG. 18a shows the waveform of an optical signal when the amount of data traffic is small and data is intermittently transmitted, such as a case where data packets are spaced long. If such burst optical signal as shown in FIG. 18a is provided to an optical amplifier, temporary periods during which no data is provided at all are observed, which are hereinafter referred to as a no-data period. If an optical signal is provided after a long no-data period, input light optical power varies. Therefore, as shown in FIG. 18b, the optical signal after amplification is instantaneously increased in level (optical surges), thereby causing degradation in the waveform.

Such waveform degradation in a transmission system makes it difficult for a receiving side to always optimally identify data. Thus, optical surges have to be suppressed. From this viewpoint, one optical amplifying device capable of carrying out optical amplification while suppressing optical surges is disclosed in Japanese Patent Laid-Open Publication No. 11-135862 (1999-135862). This conventional optical amplifying device (hereinafter referred to as conventional device) is described below with reference to the drawings.

As shown in FIG. 19, a conventional device 9000 is provided with an input optical signal of a wavelength λ_1 as shown in FIG. 20a. The provided optical signal is branched into two by an optical brancher 910. One branched optical signal goes through an optical receiver 920, an inverting amplifier 940, and a light source 924, thereby being converted into an optical signal of a wavelength λ_d with its logic level inverted, as shown in FIG. 20b. Then, the converted optical signal is multiplexed with the other optical signal branched by the optical brancher 910. The optical signal after such multiplexing is constant in optical power, as shown in FIG. 20c.

The optical signal after multiplexing is amplified by an optical fiber amplifier 916. At this time, optical surges do not

occur since the input light is constant in optical power. The amplified optical signal is provided to an optical filter 918, wherein the optical signal of the wavelength λ_1 is passed through.

As such, according to the conventional device 9000, the input optical signal is superposed with a dummy optical signal having a different wavelength. Thus, the input light provided to the amplifier 916 can become temporarily constant in optical power. In this way, optical amplification can be carried while optical surges are suppressed.

As stated above, in the conventional device, the input optical signal is superposed with the dummy optical signal, and then provided to the amplifier. Therefore, the optical signal provided to the amplifier becomes larger in optical power on average than the input optical signal. In general, amplification gain of the amplifier varies according to the average optical power of the optical signal provided to the amplifier. The larger the optical power of the input light is, the less the amplification gain is. Therefore, in the conventional device, the amplification gain of the amplifier is disadvantageously reduced.

Moreover, the conventional device has to accurately detect data provided at a higher bit rate such as 10 gigabits/second for logic level inversion. Accordingly, the electrical load on the conventional device is increased. This increase leads to a degradation in device's performance and an increase in cost.

Also, a large number of components are required for the conventional device. Thus, the conventional device is complex in structure.

SUMMARY OF THE INVENTION

Therefore, one object of the present invention is to provide an optical amplifying device capable of carrying out optical amplification while suppressing optical surges and also preventing reduction in amplification gain of an amplifier. A further object of the present invention is to provide an optical amplifying device capable of carrying out optical amplification while suppressing optical surges without requiring a large-load electrical process. A still further object of the present invention is to provide an optical amplifying device capable of carrying out optical amplification while suppressing optical surges in a simple structure.

The present invention has the following features to achieve the objects above.

A first aspect of the present invention is directed to an optical amplifying device for amplifying an input optical signal, the device comprising:

- a control electrical signal generator for generating a control electrical signal having a waveform obtained by inverting an envelope of the input optical signal;
- a light-emitter for outputting, based on the control electrical signal, a dummy optical signal having a wavelength that is different from a wavelength of the input optical signal;
- a multiplexer for multiplexing the input optical signal and the dummy optical signal;
- an amplifier for amplifying a multiplexed optical signal; and
- a separator for separating at least the input optical signal from an optical signal after amplification by the amplifier.

As described above, in the first aspect, the input optical signal is multiplexed with the dummy optical signal having a waveform obtained by inverting the envelope of the input

optical signal. Thus, optical amplification can be carried out without waveform degradation.

A second aspect of the present invention is directed to an optical amplifying device for amplifying an input optical signal, the device comprising:

- a light-emitter for transmitting the input optical signal, and emitting, based on the optical signal transmitted by the light-emitter, a dummy optical signal having a waveform obtained by inverting a waveform of the input optical signal and having a wavelength that is different from a wavelength of the input optical signal;
- a controller for controlling the wavelength of the dummy optical signal emitted from the light-emitter;
- an amplifier for amplifying the optical signal and the dummy optical signal from the light-emitter; and
- a separator for separating the input optical signal from an optical signal after amplification.

As described above, in the second aspect, by being transmitted through the light-emitter, the optical signal is multiplexed with the dummy optical signal having the waveform obtained by inverting the waveform of the input optical signal. Thus, optical amplification can be carried out in a more simplified structure without optical surges.

These and other objects, features, aspects and advantages of the present invention will become more apparent from the following detailed description of the present invention when taken in conjunction with the accompanying drawings.

BRIEF DESCRIPTION OF THE DRAWINGS

FIG. 1 is a block diagram showing the structure of an optical amplifying device **1000** according to a first embodiment of the present invention;

FIGS. 2a to 2d are diagrams showing waveforms of optical signals in the optical amplifying device **1000**;

FIGS. 3a and 3b are diagrams in assistance of explaining the operation of an optical filter **118**;

FIG. 4 is a block diagram showing the structure of a system using an optical amplifying device **1500**, which is one modification of the optical amplifying device **1000**;

FIG. 5 is a block diagram showing the structure of an optical amplifying device **2000** according to a second embodiment of the present invention;

FIGS. 6a to 6d are diagrams showing waveforms of optical signals in the optical amplifying device **2000**;

FIG. 7 is a block diagram showing the structure of an optical amplifying device **3000** according to a third embodiment of the present invention;

FIGS. 8a to 8d are diagrams showing waveforms of optical signals in the optical amplifying device **3000**;

FIG. 9 is a block diagram showing the structure of an optical amplifying device **4000** according to a fourth embodiment of the present invention;

FIGS. 10a and 10b are diagrams showing waveforms of optical signals in the optical amplifying device **4000**;

FIG. 11 is a block diagram showing the structure of an optical amplifying device **5000** according to a fifth embodiment of the present invention;

FIGS. 12a to 12c are diagrams showing waveforms of optical signals in the optical amplifying device **5000**;

FIGS. 13a and 13b are diagrams in assistance of explaining the operation of a first optical router **536**;

FIG. 14 is a block diagram showing the structure of an optical transmission system using the optical amplifying device **5000**;

FIG. 15 is a block diagram showing the structure of an optical amplifying device **6000** according to a sixth embodiment of the present invention;

FIG. 16 is a block diagram showing the structure of an optical transmission system according to a seventh embodiment of the present invention;

FIGS. 17a and 17b are diagrams in assistance of explaining the operation of a second optical router **736**;

FIGS. 18a and 18b are diagrams in assistance of explaining optical surges that occur when a burst optical signal is amplified;

FIG. 19 is a block diagram showing the structure of a conventional optical amplifying device **9000**; and

FIGS. 20a to 20c are diagrams showing waveforms of optical signals in the conventional optical amplifying device **9000**.

DESCRIPTION OF THE PREFERRED EMBODIMENTS

The embodiments of the present invention are described below with reference to the drawings.

First Embodiment

FIG. 1 is a block diagram showing the structure of an optical amplifying device according to a first embodiment of the present invention. An optical amplifying device **1000** includes an optical brancher **110**, a delay unit **112**, an optical multiplexer **114**, an optical amplifier **116**, an optical filter **118**, an optical detector **120**, a first controller **122**, and an optical signal generator **124**. With reference to FIGS. 1, 2a to 2d, 3a, and 3b, the operation of the optical amplifying device according to the present embodiment is now described.

The optical amplifying device **1000** is provided with an input optical signal having a waveform $\lambda 1$ and an amplitude α . This optical signal carries burst-like binary digital data. FIG. 2a shows the waveform of this optical signal. In FIG. 2a, a period during which binary digital data is carried on the optical signal is referred to as a data period, while a period during which no binary digital data is carried thereon is referred to as a no-data period. A dotted line indicates an envelope of the optical signal.

The optical brancher **110** branches the received optical signal into two. The optical detector **120** converts one optical signal outputted from the optical brancher **110** into an electrical signal. The first controller **122** generates a control electrical signal having a waveform obtained by inverting the envelope of the electrical signal. Based on this control electrical signal, the optical signal generator **124** produces a dummy optical signal having a waveform A_d and an amplitude $\alpha/2$. FIG. 2b shows the waveform of the dummy optical signal.

On the other hand, the other optical signal outputted from the optical brancher **110** is delayed by the delay unit **112** for a predetermined time, and then forwarded to the optical multiplexer **114**. Here, the predetermined time is a time required for the one optical signal outputted from the optical brancher **110** to go through the optical detector **120**, the first controller **122**, and then the optical signal generator **124** to become the dummy optical signal. The optical multiplexer **114** multiplexes the optical signal from the delay unit **112** and the dummy optical signal from the optical signal generator **124** together, and then produces a multiplexed optical signal. FIG. 2c shows the waveform of the multiplexed optical signal.

5

The optical amplifier **116** amplifies the multiplexed optical signal. At this time, as shown in FIG. 2c, the multiplexed optical signal is always at $\alpha/2$ in level during the no-data periods during which transmission data does not exist, and also at $\alpha/2$ in average during the data periods during which transmission data exists. Therefore, the optical signal provided to the optical amplifier **116** is approximately constant in optical power, and is not degraded in waveform when amplified.

The optical filter **118** has such a transmittance characteristic as shown in FIG. 3a to separate the optical signal of the wavelength λ_1 from the amplified optical signal having a spectrum as shown in FIG. 3b. FIG. 2d shows the waveform of the passed optical signal.

As described above, in the first embodiment, the optical signal having the wavelength λ_1 and the amplitude α to be amplified is multiplexed with the dummy optical signal having the wavelength λ_d ($\neq \lambda_1$) and the amplitude $\alpha/2$ obtained by inverting the envelope of the input optical signal. Thus, optical amplification can be carried out without waveform degradation. Furthermore, the average optical power of the optical signal provided to the optical amplifier **116** is cut in half, compared with that in the conventional device as shown in FIG. 19. Therefore, higher amplification gain can be achieved. Still further, the control electrical signal outputted from the first controller **122** is generated based on the envelope of the input optical signal. Thus, the present optical amplifying device is less electrically loaded than the conventional device shown in FIG. 19.

In the present embodiment, the dummy optical signal is one-half in amplitude of the input optical signal, but is not necessarily restricted to the above. For making the optical power to the optical amplifier **116** more constant, however, one-half the amplitude of the input optical signal is preferable, as in the present embodiment.

Furthermore, in the present embodiment, the input optical signal is a burst optical signal. Alternatively, an arbitrary optical signal can be amplified.

Still further, in the present embodiment, the input optical signal has a single wavelength, that is, only the wavelength λ_1 . Similarly, if optical signals with different wavelengths λ_1 to λ_n are provided in a time-division manner, for example, these optical signals can be amplified without degradation in waveform. In this case, however, the wavelength λ_d of the dummy optical signal has to be different from any of the wavelengths λ_1 to λ_n .

Still further, in the present embodiment, the optical filter **118** is used for the purpose of separating the optical signal of the wavelength λ_1 from the amplified optical signal. Alternatively, an optical router may be used to achieve the same purpose.

In the present embodiment, the input optical signal is converted by the optical detector **120** into an electrical signal, and the optical electrical signal is generated by the first controller **122** based on this electrical signal. Alternatively, for example, the control electrical signal may be generated based on an electrical signal to be carried on the input optical signal. Such modification example of the present embodiment is briefly described with reference to FIG. 4. In FIG. 4, components identical in structure to those in FIG. 1 are provided with the same reference numerals.

In FIG. 4, a data unit **10** produces an electrical signal carrying burst-like binary digital data. This electrical signal is converted by an optical signal generator **20** into an optical signal having a wavelength λ_1 . The optical signal is provided to an optical amplifying device **1500** as the input optical signal.

6

The electrical signal from the data unit **10** is also provided to the first controller **122** in the optical amplifying device **1500**. As in the optical amplifying device **1000** shown in FIG. 1, the first controller **122** provides the optical signal generator **124** with a control electrical signal having a waveform obtained by inverting the waveform of the electrical signal.

The optical signal generator **124** generates a dummy optical signal based on the control electrical signal. The optical multiplexer **124** multiplexes the input optical signal coming through the delay unit **112** and the dummy optical signal together. Thereafter, the operation of the optical amplifying device **1500** is the same as that of the optical amplifying device **1000** shown in FIG. 1, and therefore not described herein. As such, in the optical amplifying device **1500** according to this modification example, the same effects can be achieved as those in the optical amplifying device **1000** shown in FIG. 1.

Second Embodiment

FIG. 5 is a block diagram showing the structure of an optical amplifying device according to a second embodiment of the present invention. An optical amplifying device **2000** includes the optical brancher **110**, a delay unit **112**, the optical multiplexer **114**, the optical amplifier **116**, the optical filter **118**, a logic level determination unit **226**, a second controller **228**, and the optical signal generator **124**. Note that, in FIG. 5, components identical in structure to those in FIG. 1 are provided with the same reference numerals. With reference to FIGS. 5 and 6a to 6d, the operation of the optical amplifying device according to the second embodiment is described below.

The optical amplifying device **2000** is provided with an input optical signal having a waveform λ_1 and an amplitude α . This optical signal carries burst-like binary digital data. FIG. 6a shows the waveform of this optical signal. In FIG. 6a, a period during which binary digital data is carried on the optical signal is referred to as a data period, while a period during which no binary digital data is carried thereon is referred to as a no-data period.

The optical brancher **110** branches the received optical signal into two. The logic level determination unit **226** determines the level of the binary digital data carried on one optical signal outputted from the optical brancher **110**. The second controller **228** generates a control electrical signal based on a determination made by the logic level determination unit **226**. This control electrical signal becomes $\alpha/2$ in level from 0, for example, when the logic level determination unit **226** determines that the value of the digital data continuously indicates 0 for more than a predetermined time **A1**, and returns to "0" when the value of the digital data becomes 1. The time **A1** is predetermined based on physical characteristics of the optical amplifier **116**, such as a relaxation time constant, and other factors. Based on this control electrical signal, the optical signal generator **124** produces a dummy optical signal having the wavelength λ_d and the amplitude $\alpha/2$. FIG. 6b shows the waveform of this dummy optical signal.

On the other hand, the other optical signal outputted from the optical brancher **110** is delayed by the delay unit **112** for a predetermined time, and then forwarded to the optical multiplexer **114**. Here, the predetermined time is a time required for the one optical signal outputted from the optical brancher **110** to go through the logic level determination unit **226**, the second controller **228**, and then the optical signal generator **124** to become the dummy optical signal. The

optical multiplexer **114** multiplexes the optical signal from the delay unit **112** and the dummy optical signal from the optical signal generator **124** together, and then produces a multiplexed optical signal. FIG. **6c** shows the waveform of the multiplexed optical signal.

The effects of optical surges that occur when the input optical signal is changed in level from 0 to α become larger as the period at the level 0 before the change is longer. Therefore, if the no-data period continues for more than the predetermined time **A1**, the input optical signal is multiplexed with the dummy optical signal so that the no-data period of the multiplexed optical signal provided to the optical amplifier **116** does not continue for more than the time **A1**. Thus, the effects of optical surges at amplification can be suppressed within a permissible range.

The optical amplifier **116** amplifies the multiplexed optical signal. At this time, as shown in FIG. **6c**, a period during which the multiplexed optical signal is at the "0" level is, at most, the time **A1**.

After amplification, similarly to the first embodiment, the optical filter **118** separates the optical signal having the wavelength λ_1 from the amplified optical signal. FIG. **6d** shows the waveform of the separated optical signal.

As described above, according to the second embodiment, the no-data period of the multiplexed optical signal provided to the optical amplifier **116** is controlled so as to become, at most, the time **A1**. Thus, the effects of optical surges at amplification can be suppressed within a permissible range. Moreover, the average optical power of the optical signal provided to the optical amplifier **116** is smaller than that in the conventional device shown in FIG. **19**. Thus, more amplification gain can be obtained.

Third Embodiment

FIG. **7** is a block diagram showing the structure of an optical amplifying device according to a third embodiment of the present invention. An optical amplifying device **3000** includes the optical brancher **110**, the delay unit **12**, the optical multiplexer **114**, the optical amplifier **116**, the optical filter **118**, the logic level determination unit **226**, a third controller **330**, and the optical generator **124**. Note that, in FIG. **7**, components identical in structure to those shown in FIG. **5** are provided with the same reference numerals. With reference to FIGS. **7** and **8a** to **8d**, the operation of the optical amplifying device according to the third embodiment is described below.

The optical amplifying device **3000** is provided with an input optical signal having a waveform λ_1 and an amplitude α . This optical signal carries burst-like binary digital data. FIG. **8a** shows the waveform of this optical signal.

The optical brancher **110** branches the received optical signal in two. The logic level determination unit **226** determines the level of the binary digital data carried on one optical signal outputted from the optical brancher **110**. The third controller **330** generates a control electrical signal based on a determination made by the logic level determination unit **226**. The generated control electrical signal has pulses with the amplitude a and a width **A2**, for example. Every time when the logic level determination unit **226** determines that the value of the data continuously indicates "0" for more than the predetermined time **A1**, the pulse is outputted. The time **A1** is predetermined based on a relaxation time constant of the optical amplifier **116** and other factors. Based on this control electrical signal, the optical signal generator **124** produces a dummy optical signal having the wavelength λ_d . FIG. **8b** shows the waveform of this dummy optical signal.

On the other hand, the other optical signal outputted from the optical brancher **110** is delayed by the delay unit **112** for a predetermined time, and then forwarded to the optical multiplexer **114**. Here, the predetermined time is a time required for the one optical signal outputted from the optical brancher **110** to go through the logic level determination unit **226**, the third controller **330**, and then the optical signal generator **124** to become the dummy optical signal. The optical multiplexer **114** multiplexes the optical signal from the delay unit **112** and the dummy optical signal from the optical signal generator **124** together, and then produces a multiplexed optical signal. FIG. **8c** shows the waveform of the multiplexed optical signal.

The effects of optical surges that occur when the input optical signal is changed in level from 0 to α become larger as the period at the level 0 before the change is longer. Therefore, if the no-data period continues for more than the predetermined time **A1**, the input optical signal is multiplexed with the dummy optical signal so that the no-data period of the multiplexed optical signal provided to the optical amplifier **116** does not continue for more than the time **A1**. Thus, the effects of optical surges at amplification can be suppressed within a permissible range.

The optical amplifier **116** amplifies the multiplexed optical signal. At this time, as shown in FIG. **8c**, a period during which the multiplexed optical signal is at the "0" level is, at most, the time **A1**.

After amplification, similarly to the first embodiment, the optical filter **118** separates the optical signal of the wavelength λ_1 from the amplified optical signal. FIG. **8d** shows the waveform of the separated optical signal.

In the present embodiment, the pulse width **A2** is fixed, but may be variable if, for example, the pulses of the dummy optical signal overlap with the data period of the input optical signal. In such case, pulses are changed to be shorter in width for preventing the overlapping.

As described above, according to the third embodiment, the no-data period of the multiplexed optical signal provided to the optical amplifier **116** is controlled so as to become the time **A1** at most. Thus, the effects of optical surges at amplification can be suppressed within a permissible range. Moreover, the average optical power of the optical signal provided to the optical amplifier **116** is significantly smaller than that in the conventional device shown in FIG. **19**. Thus, more amplification gain can be obtained.

Note that, in the second and third embodiments, the input optical signal is a burst optical signal. Alternatively, similarly to the case in the first embodiment, an arbitrary optical signal can be amplified.

Furthermore, in the second and third embodiments, the input optical signal has a single wavelength, that is, only the wavelength λ_1 . Similarly, if optical signals with different wavelengths λ_1 to λ_n are provided in a time-division manner, for example, these optical signal can be amplified without degradation in waveform. In this case, however, the wavelength λ_d of the dummy optical signal has to be different from any of the wavelengths λ_1 to λ_n .

Still further, in the second and third embodiments, the optical filter **118** is used for the purpose of separating the optical signal of the wavelength λ_1 from the amplified optical signal. Alternatively, an optical router may be used to achieve the same purpose.

Still further, in the second and third embodiments, based on the determination made by the logic level determination unit **226**, the second and third controller **228** and **330** generate the control electrical signal. Alternatively, for

example, the control electrical signal may be generated based on an electrical signal to be carried on the input optical signal.

Fourth Embodiment

FIG. 9 is a block diagram showing the structure of an optical amplifying device according to a fourth embodiment of the present invention. An optical amplifying device **4000** includes a semiconductor laser **432**, a controller **434**, the optical amplifier **116**, and the optical filter **118**. Note that, in FIG. 9, components identical in structure to those shown in FIG. 1 are provided with the same reference numerals. With reference to FIGS. 9, 10a, and 10b, the operation of the optical amplifying device according to the present embodiment is now described.

The optical amplifying device **4000** is provided with an input optical signal having a waveform **21**. This optical signal carries burst-like binary digital data. FIG. 10a shows the waveform of this optical signal.

The semiconductor laser **432** is controlled by the controller **434** so as to produce an optical signal having a wavelength λ_d and identical in amplitude of the received optical signal having the wavelength λ_1 . The semiconductor laser **432** is implemented as a distributed Bragg reflector (DBR) type semiconductor laser, for example. Such a semiconductor laser has characteristics of, when an optical signal having a wavelength different from that of the semiconductor laser is externally provided thereto, suppressing oscillation thereof and transmitting this externally-provided optical signal.

In other words, while the input light with wavelength λ_1 to the semiconductor laser **432** is 0 in optical power, that is, while the optical power is 0 during both of the data and no-data periods shown in FIG. 10a, the semiconductor laser **432** produces an optical signal of predetermined power having a wavelength λ_d under the control of the controller **434**. On the other hand, while the input light to the semiconductor laser **432** is not 0 in optical power, the semiconductor laser **432** is suppressed in oscillation in response to the optical power. Therefore, the waveform of the optical signal having the wavelength λ_d outputted from the semiconductor laser **432** becomes the inverted one of the input light, as shown in FIG. 10b. This optical signal of the wavelength λ_d corresponds to the dummy optical signal in the above-described conventional device and optical amplifying device according to the first embodiment.

From the semiconductor laser **432**, the light of the wavelength λ_1 transmitted therethrough and the above-stated dummy optical signal of the wavelength λ_d are both outputted. As stated above, the light and the dummy optical signal are inverted in waveform to each other. Therefore, the light outputted from the semiconductor laser **432** is constant in optical power.

The light outputted from the semiconductor laser **432** is amplified by the optical amplifier **116**. At this time, the light provided to the optical amplifier **116** is approximately constant in optical power, and therefore optical surges do not occur. After amplification, the optical filter **118** passes the optical signal of the wavelength λ_1 .

As described above, in the fourth embodiment, the optical signal of the wavelength λ_1 to be amplified is provided to the semiconductor laser **432** oscillating with the wavelength λ_d that is different from the wavelength λ_1 . Thus, an optical signal constant in optical power and composed of the input optical signal superposed with the dummy signal is produced. Therefore, the optical amplifying device capable of

carrying out optical amplification without degradation in waveform can be achieved in a more simplified structure, compared with the above-described conventional device and the optical amplification device according to the first embodiment.

In the present embodiment, the input optical signal is a burst optical signal. Alternatively, an arbitrary optical signal can be amplified.

Furthermore, in the present embodiment, the input optical signal has a single wavelength, that is, only the wavelength λ_1 . Similarly, if optical signals with different wavelengths λ_1 to λ_n are provided in a time-division manner, for example, these optical signals can be amplified without degradation in waveform. In this case, however, the wavelength λ_d of the dummy optical signal has to be different from any of the wavelengths λ_1 to λ_n .

Still further, in the present embodiment, the optical filter **118** is used for the purpose of separating the optical signal of the wavelength λ_1 from the amplified optical signal. Alternatively, an optical router may be used to achieve the same purpose. If the optical router is used, the dummy optical signal may be used for data transmission or feedback control. Described below are modification examples according to the present embodiment, as fifth and sixth embodiments.

Fifth Embodiment

FIG. 11 is a block diagram showing the structure of an optical amplifying device according to the fifth embodiment of the present invention. An optical amplification device **5000** includes the semiconductor laser **432**, the controller **434**, the optical amplifier **116**, and a first optical router **536**. Note that, in FIG. 11, components identical in structure to those in FIG. 9 are provided with the same reference numerals. With reference to FIGS. 11 and 12a to 12c, the operation of the optical amplifying device according to the present embodiment is now described. Note that the fifth embodiment is different from the fourth only in that the first optical router **536** is provided instead of the optical filter **118**. Therefore, the other components are not described in detail herein.

The optical amplifying device **5000** is provided with an input optical signal having a waveform λ_1 . FIG. 12a shows the waveform of this optical signal. Similarly to the fourth embodiment, the optical signal transmitted through the semiconductor that oscillates with a wavelength λ_d is multiplexed with a dummy optical signal of the wavelength λ_d , and then amplified by the optical amplifier **116**.

The amplified optical signal is provided to the first optical filter **536**. The first optical filter **536** has first and second output ports each having transmittance characteristics as shown in FIG. 13a. Out of the amplified optical signal having a spectrum shown in FIG. 13b, the first optical router **536** outputs the optical signal of the wavelength λ_1 from the first output port and the dummy optical signal of the wavelength λ_d from the second output port. FIG. 12b shows the waveform of the optical signal outputted from the first output port, while FIG. 12c shows that of the optical signal outputted from the second output port.

As evident from FIGS. 12b and 12c, the optical signals outputted from the first and second output ports are inverted in waveform, but these signals carry the same information. Therefore, by transmitting both of the optical signals, the information identical to that carried on the input optical signal can be transmitted.

As such, in the fifth embodiment, not only the optical signal of the wavelength λ_1 to be amplified but also the

11

dummy optical signal of the wavelength λ_d is used for data transmission. Thus, the generated optical signals can be utilized more effectively.

In the present embodiment, the input optical signal is a burst optical signal. Alternatively, an arbitrary optical signal can be amplified.

Furthermore, in the present embodiment, the input optical signal has a single wavelength, that is, only the wavelength λ_1 . Similarly, if optical signals with different wavelengths λ_1 to λ_n are provided in a time-division manner, for example, these optical signals can be amplified without degradation in waveform. In this case, however, the wavelength λ_d of the dummy optical signal has to be different from any of the wavelengths λ_1 to λ_n .

In the present embodiment, the first optical router **536** has two output ports. Alternatively, the first optical router **536** may have three or more output ports for outputting lights of the wavelengths λ_1 to λ_n and λ_d .

Here, consider a case where the optical amplifying device **5000** according to the present embodiment is used to construct a system as shown in FIG. **14**. If a distance L_1 between the optical amplifying device **5000** and a first optical receiver **30** is different from a distance L_2 between the optical amplifying device **5000** and a second optical receiver **32**, optical signals of wavelengths λ_1 and λ_d both outputted from the optical amplifying device **5000** are disadvantageously different in transmission characteristic (S/N ratio), even though they are identical in amplitude.

To get around the above problem, if the distance L_1 is longer than the distance L_2 , the controller **434** controls the dummy optical signal of the wavelength λ_d outputted from the semiconductor laser **432** to be smaller in amplitude than the optical signal of the wavelength λ_1 to be amplified. Thus, the same transmission characteristics can be observed in these optical signals and, by extension, in the system as a whole.

Sixth Embodiment

FIG. **15** is a block diagram showing the structure of an optical amplifying device according to the sixth embodiment of the present invention. An optical amplifying device **6000** includes the semiconductor laser **432**, the controller **434**, the optical amplifier **116**, and the first optical router **536**. Note that, in FIG. **15**, components identical in structure to those shown in FIG. **11** are provided with the same reference numerals. With reference to FIG. **15**, the operation of the optical amplifying device according to the present embodiment is now described. The optical amplifying device according to the sixth embodiment is different from that according to the fifth only in that the optical signal of the wavelength λ_d outputted from the first optical router **536** is used not for transmission but for control of the output light from the semiconductor laser **432**. Therefore, the other components are not described in detail herein.

The optical signal of the wavelength λ_d outputted from the first optical router **536** in a manner similar to that in the fifth embodiment is provided to the controller **434**. The controller **434** monitors this optical signal to control the semiconductor laser **432** so that the oscillation wavelength thereof becomes the wavelength λ_d and that the dummy optical signal from the semiconductor laser **432** becomes equal in amplitude to the optical signal of the wavelength λ_1 to be amplified.

In general, semiconductor lasers are feedback-controlled based on light output therefrom. However, in the present embodiment, the output light from the semiconductor laser

12

432 includes the light of the wavelength λ_1 and the dummy optical signal of the wavelength λ_d , and therefore cannot be referred to for feedback control. For this reason, in the present embodiment, the first optical router **536** separates the controller **434** with the optical signal of the wavelength λ_d from the amplified optical signal for feedback control.

As described above, according to the present embodiment, the optical signal of the wavelength λ_d outputted from the first optical router **536** is monitored. Thus, in addition to the effects similar to those in the fourth embodiment, the optical amplifying device according to the fifth embodiment has an effect such that the output light from the semiconductor laser **432** can be controlled more accurately.

With reference to FIGS. **16**, **17a**, and **17b**, described is a system in which an optical signal is amplified by an optical amplifying device and then again amplified for long-distance transmission

Seventh Embodiment

FIG. **16** is a block diagram showing the structure of an optical transmission system according to a seventh embodiment of the present invention. The optical transmission system includes an optical amplifying device **7000**, second optical amplifiers **40a** and **40b**, and optical filters **50a** and **50b**. The optical amplifying device **7000** includes semiconductor lasers **732a** and **732b**, controllers **734a** and **734b**, an optical multiplexer **738**, the first optical amplifier **116**, and a second optical router **736**. Note that the first optical amplifier **116** shown in FIG. **16** is identical in structure to the optical amplifier **116** shown in FIG. **11**. The operation of the present optical transmission system is now described below.

The optical amplifying device **7000** is provided with two optical signals having different wavelengths, one with a wavelength λ_1 and the other with a wavelength λ_2 . The optical signal of the wavelength λ_1 is provided to the semiconductor laser **732a**, which is controlled by the controller **734a**, and then multiplexed with a dummy optical signal of a wavelength λ_{d1} . On the other hand, the optical signal of the wavelength λ_2 is provided to the semiconductor laser **732b**, which is controlled by the controller **734b**, and then multiplexed with a dummy optical signal of a wavelength of λ_{d2} .

Output lights from the semiconductor lasers **732a** and **732b** are multiplexed with each other by the optical multiplexer **738**, and then amplified by the first optical amplifier **116**. At this time, the output lights from the semiconductor lasers **732a** and **732b** are constant in optical power and, accordingly, an output light from the optical multiplexer **738** is also constant in optical power. Therefore, optical surges at optical amplification do not occur in the first optical amplifier **116**.

The amplified optical signal is provided to the second optical router **736**. The second optical router **736** has first and second output ports, and is structured as an AWG (Arrayed Wave Guide) having cyclic transmittance characteristics as shown in FIG. **17a**. Of the input optical signal having a spectrum shown in FIG. **17b**, the second optical router **736** outputs, from the first output port, the optical signal of the wavelength λ_1 to be amplified and the dummy optical signal of the wavelength λ_{d1} and, from the second output port, the optical signal of the wavelength λ_2 to be amplified and the dummy optical signal of the wavelength λ_{d2} .

The optical signal outputted from the first output port is again amplified by the second optical amplifier **40a** in the

13

course of transmission through an optical fiber. The optical signal inputted to the second optical amplifier 40a is constant in optical power, like the output light from the semiconductor laser 732a. Therefore, optical surges at optical amplification do not occur in the second optical amplifier 40a. The amplified optical signal is provided to the optical filter 50a that passes the optical signal of the wavelength $\lambda 1$.

Similarly, the optical signal outputted from the second output port is again amplified by the second optical amplifier 40b, and then provided to the optical filter 50b that passes the optical signal of the wavelength $\lambda 2$.

As described above, according to the present embodiment, when the amplified optical signal is transmitted through a router, the input optical signal and the dummy optical signal are both outputted from the same port for transmission. Therefore, optical surges do not occur when the optical signal from the router is again amplified by another optical amplifier. Thus, amplification can be carried out twice or more without further requiring such device as the optical amplifying device 4000 shown in FIG. 9 for suppressing optical surges. Consequently, the system can be simplified in structure.

While the invention has been described in detail, the foregoing description is in all aspects illustrative and not restrictive. It is understood that numerous other modifications and variations can be devised without departing from the scope of the invention.

What is claimed is:

1. An optical amplifying device for amplifying an input optical signal, said device comprising:

a light-emitting means for transmitting the input optical signal and emitting, based on the optical signal transmitted by said light-emitting means, a dummy optical signal having a waveform obtained by inverting a waveform of the input optical signal and having a wavelength that is different from a wavelength of the input optical signal;

a control means for controlling the wavelength of the dummy optical signal emitted from said light-emitting means;

an amplifying means for amplifying the optical signal and the dummy optical signal transmitted from said light-emitting means, and outputting an amplified optical signal; and

a separating means for separating the input optical signal from the amplified optical signal outputted by said amplifying means.

2. The optical amplifying device according to claim 1, wherein the dummy optical signal is equal in amplitude to the input optical signal.

3. The optical amplifying device according to claim 1, wherein said control means controls the wavelength and an amplitude of the dummy optical signal emitted from said light-emitting means.

4. The optical amplifying device according to claim 1, wherein said separating means separates the input optical signal and the dummy optical signal individually.

5. The optical amplifying device according to claim 4, wherein said control means carries out feedback control of said light-emitting means based on the dummy optical signal separated by said separating means.

6. The optical amplifying device according to claim 4, wherein said control means controls the wavelength and an amplitude of the dummy optical signal emitted from said light-emitting means, and carries out feedback control of said light-emitting means based on the dummy optical signal separated by said separating means.

14

7. The optical amplifying device according to claim 1, wherein said separating means collectively separates the input optical signal and the dummy optical signal.

8. The optical amplifying device according to claim 7, wherein said separating means is an optical router with an AWG (Arrayed Wave Guide) structure.

9. The optical amplifying device according to claim 1, wherein said light-emitting means is a distributed Bragg reflector (DBR) type semiconductor laser.

10. The optical amplifying device according to claim 1, wherein the input optical signal is a burst optical signal.

11. An optical amplifying method for amplifying an input optical signal, said method comprising:

supplying the input optical signal to a light emitting device for transmitting the input optical signal, and emitting[, based on the transmitted input optical signal,] a dummy optical signal *while the input optical signal is not transmitted, the dummy optical signal having a waveform obtained by inverting a waveform of the input optical signal and having a wavelength that is different from a wavelength of the input optical signal;*

collectively amplifying the input optical signal and the dummy optical signal transmitted from the light emitting device, and outputting an amplified optical signal; and

separating the input optical signal from the amplified optical signal.

12. An optical amplifying device for amplifying an input optical signal, said device comprising:

a light-emitting device operable to transmit the input optical signal and emit, based on the optical signal transmitted by said light-emitting device, a dummy optical signal having a waveform obtained by inverting a waveform of the input optical signal and having a wavelength that is different from a wavelength of the input optical signal;

a control device operable to control the wavelength of the dummy optical signal emitted from said light-emitting device;

an amplifying device operable to amplify the optical signal and the dummy optical signal transmitted from said light-emitting device, and output an amplified optical signal; and

a separating device operable to separate the input optical signal from the amplified optical signal outputted by said amplifying device.

13. The optical amplifying device according to claim 12, wherein the dummy optical signal is equal in amplitude to the input optical signal.

14. The optical amplifying device according to claim 12, wherein said control device is operable to control the wavelength and an amplitude of the dummy optical signal emitted from said light-emitting device.

15. The optical amplifying device according to claim 12, wherein said separating device is operable to separate the input optical signal and the dummy optical signal individually.

16. The optical amplifying device according to claim 15, wherein said control device is operable to carry out feedback control of said light-emitting device based on the dummy optical signal separated by said separating device.

17. The optical amplifying device according to claim 15, wherein said control device is operable to control the wavelength and an amplitude of the dummy optical signal emitted from said light-emitting device, and carry out feed-

15

back control of said light-emitting device based on the dummy optical signal separated by said separating device.

18. The optical amplifying device according to claim 12, wherein said separating device collectively separates the input optical signal and the dummy optical signal.

19. The optical amplifying device according to claim 18, wherein said separating device is an optical router with an AWG (Arrayed Wave Guide) structure.

20. The optical amplifying device according to claim 12, wherein said light-emitting device is a distributed Bragg reflector (DBR) type semiconductor laser.

21. The optical amplifying device according to claim 12, wherein the input optical signal is a burst optical signal.

22. The optical amplifying device according to claim 1, wherein said separating means is an optical filter.

23. The optical amplifying device according to claim 12, wherein said separating device is an optical filter.

24. *An optical amplifying apparatus for amplifying an input optical signal, said apparatus comprising:*

a light-emitter operable to transmit the input optical signal and emit a dummy optical signal while the input optical signal is not transmitted, the dummy optical signal having a waveform obtained by inverting a waveform of the input optical signal and having a

16

wavelength that is different from a wavelength of the input optical signal;

an amplifier operable to amplify the transmitted input optical signal and the dummy optical signal and output an amplified optical signal; and

a separator operable to separate an output optical signal, corresponding to the input optical signal, from the amplified optical signal.

25. *An optical amplifying method for amplifying an input optical signal, said method comprising:*

transmitting the input optical signal and emitting a dummy optical signal while the input optical signal is not transmitted, the dummy optical signal having a waveform obtained by inverting a waveform of the input optical signal and having a wavelength that is different from a wavelength of the input optical signal;

amplifying the transmitted input optical signal and the dummy optical signal, and outputting an amplified optical signal; and

separating an output optical signal, corresponding to the input optical signal, from the amplified optical signal.

* * * * *