

US00RE40220E

(19) **United States**
(12) **Reissued Patent**
Nichols et al.

(10) **Patent Number: US RE40,220 E**
(45) **Date of Reissued Patent: *Apr. 8, 2008**

(54) **CHECK WRITING POINT OF SALE SYSTEM**

FOREIGN PATENT DOCUMENTS

(75) Inventors: **Henry R. Nichols**, McLean, VA (US);
Robert R. Hills, Sugarloaf Key, FL
(US)

FR 1602509 1/1971
FR 2133914 12/1972
FR 2366648 4/1978

(Continued)

(73) Assignee: **LML Patent Corp.**, Vancouver, B.C.
(CA)

OTHER PUBLICATIONS

(*) Notice: This patent is subject to a terminal disclaimer.

Glover, Mark. "Cashless Society Expands." Sacramento Bee, Nov. 7, 1995, p. E1. McClatchy Newspapers, Inc., Sacramento, CA.

(21) Appl. No.: **10/889,639**

(Continued)

(22) Filed: **Jul. 12, 2004**

Primary Examiner—Karl D. Frech

(74) Attorney, Agent, or Firm—Roberts, Mardula & Wertheim, LLC

Related U.S. Patent Documents

Reissue of:

(64) Patent No.: **6,547,129**
Issued: **Apr. 15, 2003**
Appl. No.: **10/096,019**
Filed: **Mar. 11, 2002**

(57) **ABSTRACT**

A point of sale system designed to read information from a consumer's check, credit card, or manual input with a subsequent debiting of a consumer's account and crediting merchant's account for the goods or services provided. Point of sale terminals are designed to accept a form of credit card with a consumer's bank account information encoded thereon or in the alternative to read the MICR number from a consumer's check in order to verify that a consumer has an appropriate balance to conduct the transaction with a given merchant. Thereafter the transaction of that information is transmitted to a central computer system which verifies the consumer's credit worthiness and stores the transaction event information for subsequent bank reconciliation via the ACH or other competing network. The invention eliminates the need for paper checks with all bank reconciliation being accomplished electronically. The present invention also includes fraud protection provisions such as velocity controls, social security checks, and scans. The present invention has the further flexibility to differentiate between "first time" consumer usage and those limits otherwise assigned to "known" consumer accounts. Additionally, there is not need for the present system to retain the consumer's check after verification.

U.S. Applications:

(63) Continuation of application No. 09/851,609, filed on May 9, 2001, now Pat. No. 6,354,491, which is a division of application No. 09/562,303, filed on May 1, 2000, now Pat. No. 6,283,366, which is a continuation of application No. 08/775,400, filed on Dec. 31, 1996, now Pat. No. 6,164,528.

(51) **Int. Cl.**
G07F 19/00 (2006.01)

(52) **U.S. Cl.** **235/379; 235/380**

(58) **Field of Classification Search** **235/379,**
235/380
See application file for complete search history.

(56) **References Cited**

U.S. PATENT DOCUMENTS

3,061,143 A 10/1962 Simjian
3,609,248 A 9/1971 Wolf et al.
3,824,544 A 7/1974 Simjian

(Continued)

100 Claims, 8 Drawing Sheets

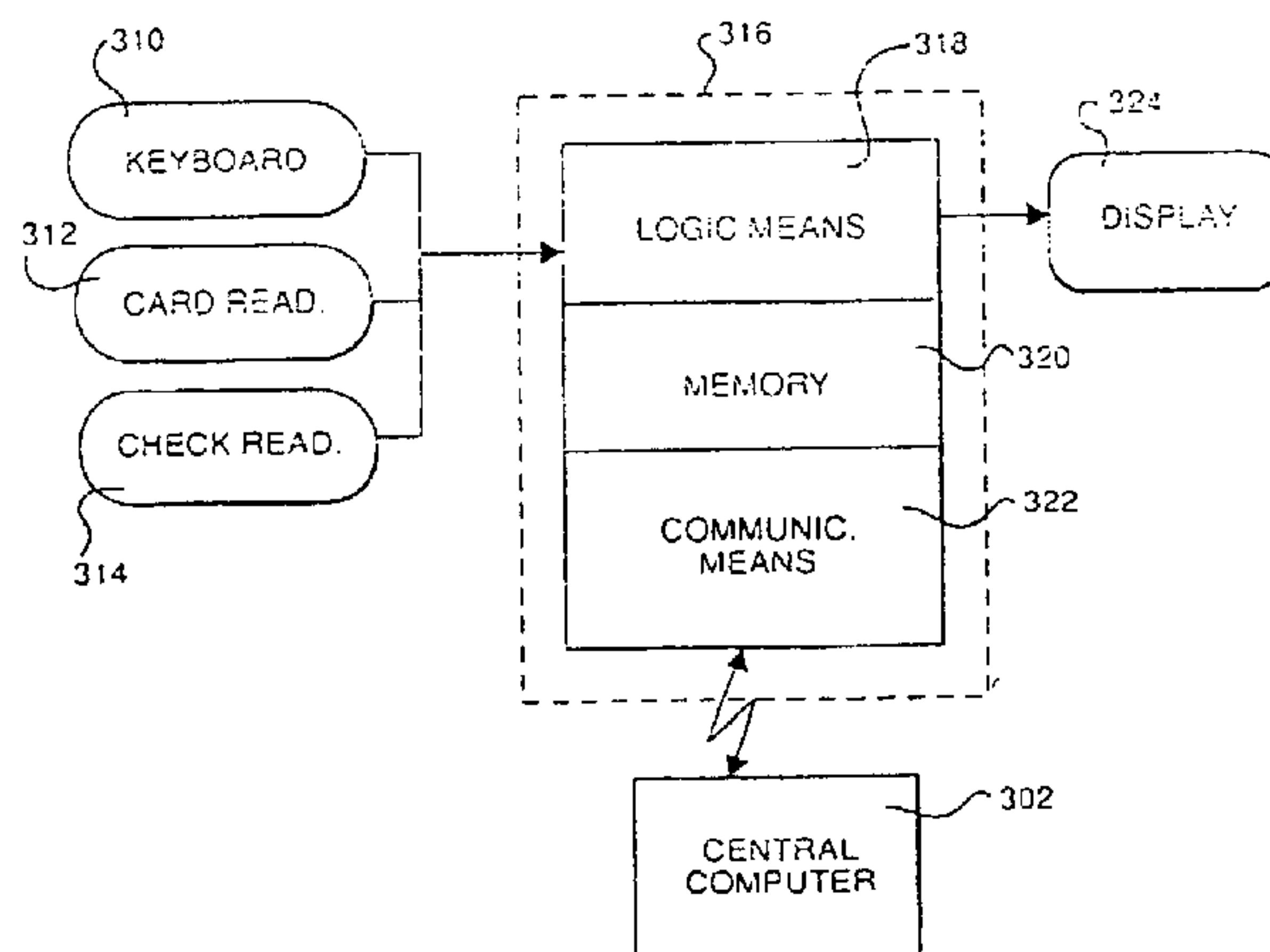

U.S. PATENT DOCUMENTS

3,845,470	A	10/1974	Schuller	
3,985,998	A	10/1976	Crafton	
3,990,558	A	11/1976	Ehrat	
4,053,735	A	10/1977	Foudos	
4,109,238	A	8/1978	Creekmore	
4,249,163	A	2/1981	Maurer et al.	
4,270,042	A	5/1981	Case	
4,321,672	A	3/1982	Braun et al.	
4,404,649	A	9/1983	Nunley et al.	
4,523,330	A	6/1985	Cain	
4,580,040	A	4/1986	Granzow et al.	
4,617,457	A	10/1986	Granzow et al.	
4,672,377	A	6/1987	Murphy et al.	
4,673,802	A	6/1987	Ohmae et al.	
4,678,895	A	7/1987	Tateisi et al.	
4,678,896	A	7/1987	Carlson et al.	
4,727,243	A	2/1988	Savar	
4,743,743	A	5/1988	Fukatsu	
4,758,714	A	7/1988	Carlson et al.	
4,810,866	A	3/1989	Lord, Jr.	
4,823,264	A	4/1989	Deming	
4,933,536	A	6/1990	Lindemann et al.	
4,934,772	A	6/1990	Sakuma et al.	
5,053,607	A	10/1991	Carlson et al.	
5,175,682	A	12/1992	Higashiyama et al.	
5,237,620	A	8/1993	Deaton et al.	
5,256,863	A	10/1993	Ferguson et al.	
5,305,196	A	4/1994	Deaton et al.	
5,426,281	A	6/1995	Abecassis	
5,438,186	A	8/1995	Nair et al.	
5,455,407	A	10/1995	Rosen	
5,484,988	A	1/1996	Hills et al.	
5,496,991	A	3/1996	Delfer, III et al.	
5,500,513	A	3/1996	Langhans et al.	
5,677,955	A *	10/1997	Doggett et al.	705/76
5,679,938	A	10/1997	Templeton et al.	
5,703,344	A	12/1997	Bezy et al.	
6,354,491	B2 *	3/2002	Nichols et al.	235/379

FOREIGN PATENT DOCUMENTS

FR	2377510	8/1978
FR	2441222	6/1980
JP	54-119859	* 9/1979

OTHER PUBLICATIONS

Interregional ACH Exchange Task Force. Interregional ACH Exchange Pilot Evaluation Report. Dec. 1977.
 Special to the American Banker. "Truncation of Holder Checks Set." The American Banker, Nov. 19, 1979, p. 2.
 Kutler, Jeffrey. "Check Truncation Test on Schedule as Bankers Reach Three Critical Decisions." The American Banker, Feb. 4, 1980, p. 1.
 Golson, James P. "ACH: Fewer Problems, More Opportunities." ABA Banking Journal, Mar. 1980, pp. 105-110.
 Kutler, Jeffrey. "ABA Vows to Win CEOs on ACH Use; NACHA Assails Proposed Fed Curbs; Vote of Confidence," The American Banker, Mar. 5, 1980, p. 1.
 Slater, Karen. "ABA Truncation Test Faces Delay; Nationwide Phone Next Advances." The American Banker, May 22, 1980, p. 1.

Kutler, Jeffrey. "ABA Checks Safekeeping Task Force to Use ACH Net, Bank Wire for Pilot Test Media." The American Banker, Jun. 16, 1980, p. 2.
 Orr, Bill. "An ACH Growing Pain: What Caused It, What Will Relieve It." ABA Banking Journal, Aug. 1980, pp. 87-90.
 Kutler, Jeffrey. "Truncation Dispute Is Settled." The American Banker, Sep. 26, 1980, p. 1.
 Washington Bureau. "First 7 Banks Picked for Truncation Test." The American Banker, Nov. 25, 1980, p. 2.
 Orr, Bill. "ACH: What's In It for Community Banks?" ABA Banking Journal, Apr. 1981, pp. 52-55.
 Streeter, Bill. "ACH Viewed from the Corporate Side." ABA Banking Journal, Oct. 1981, pp. 197-202.
 Lordan, James F. "A Fresh Approach to the Potential of ACH." ABA Banking Journal, Mar. 1982, pp. 128-130.
 "Checks in Transition: Why, and How Fast?" Special Report, ABA Banking Journal, Jun. 1982, pp. 38-47.
 Braun, Edward L. The Flexacheck System. Paper Presented at Bank Stationers Association Annual Meeting, May 9, 1984.
 "Self-Service Branch Uses Zero Personnel." Banking Magazine, believed published in May 1973, p. 66.
 "Just Cashing a Check? Diebold's Way is Faster." Banking Magazine, May 1973, pp. 77.
 Coenen, Paul F.P. "The Nonfinancial Uses of EFT." United States Banker, Feb. 1986, p. 76.
 Gullo, Karen. "An Alternative to Check Handling; Western Union Unit to Test Point-of-Sale Payments." The American Banker, Apr. 10, 1990, section: Technology News, p. 3.
 "BUYPass Corporation Introduces Coproate Check Router Solutions for Supermarkets." PR Newswire, May 8, 1995, section: Financial News.
 Bypass Electronic Transaction Systems, Inc. Introducing the Complete Point-of-Sale System Designed by Bankers, for Bankers, Consumers and Retailers. Marketing materials, believed published in 1984.
 Nova Information Systems, Inc. Answer, Additional Defenses and Counterclaim of Defendant Nova Information Systems, Inc. *LML Patent Corp. v. Telecheck Services, Inc., et al.*, Civil Action No. 04-858-SLR, U.S. District Court for the District of Delaware. Sep. 17, 2004.
 Electronic Clearing House, Inc.; Xpresschex, Inc. Amended Answer and Affirmative Defenses of Electronic Clearing House, Inc. and Xpresschex, Inc. to LML Patent Corp.'s Complaint for Patent Infringement. *LML Patent Corp. v. Telecheck Services, Inc., et al.*, Civil Action No. 04-858-SLR, U.S. District Court for the District of Delaware. Oct. 7, 2004.
 Telecheck Services, Inc. Telecheck's Fifth Supplemental Response to LML's Amended First Set of Interrogatories. *LML Patent Corp. v. Telecheck Services, Inc., et al.*, Civil Action No. 04-858-SLR, U.S. District Court for the District of Delaware. May 20, 2005.

* cited by examiner

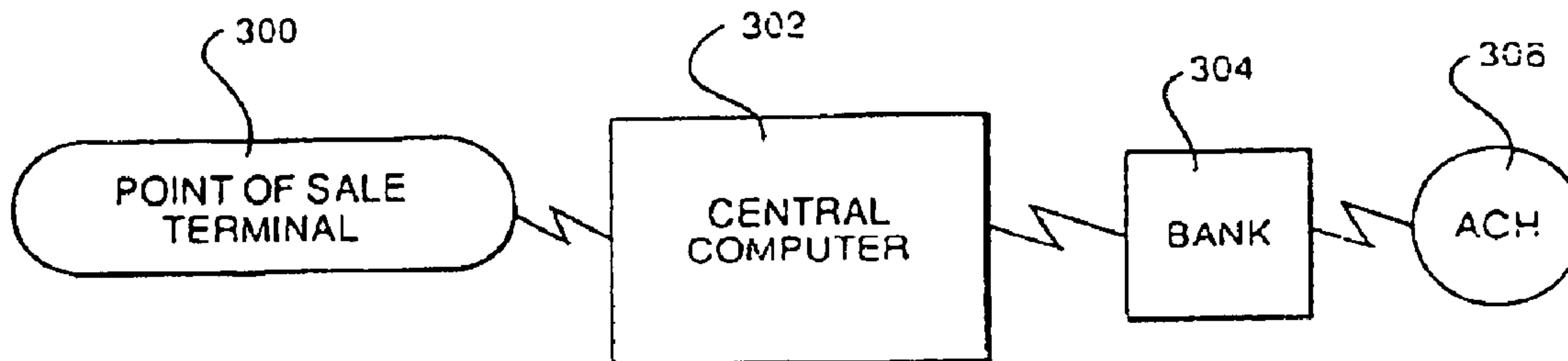

FIG. 1

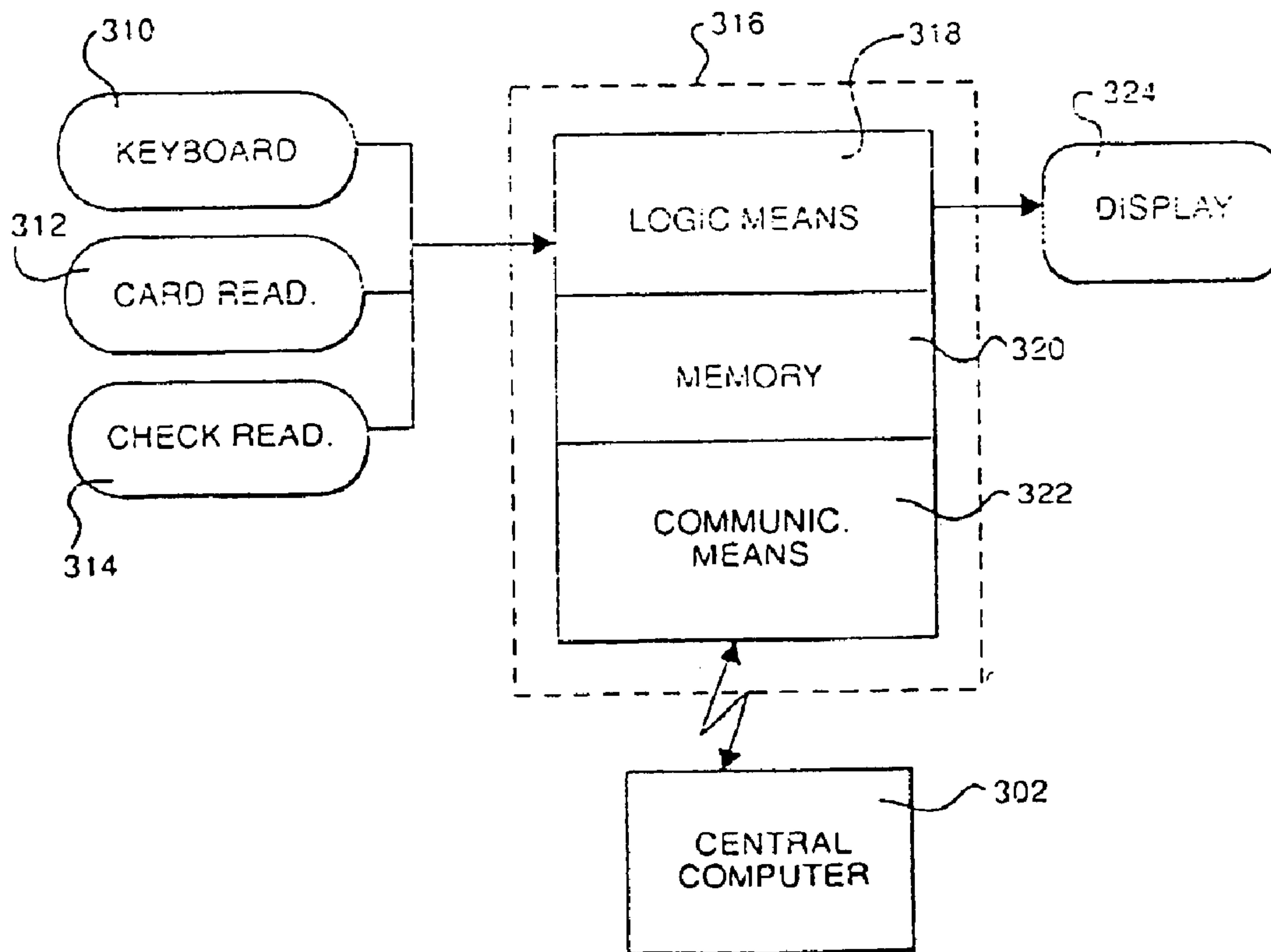

FIG. 2

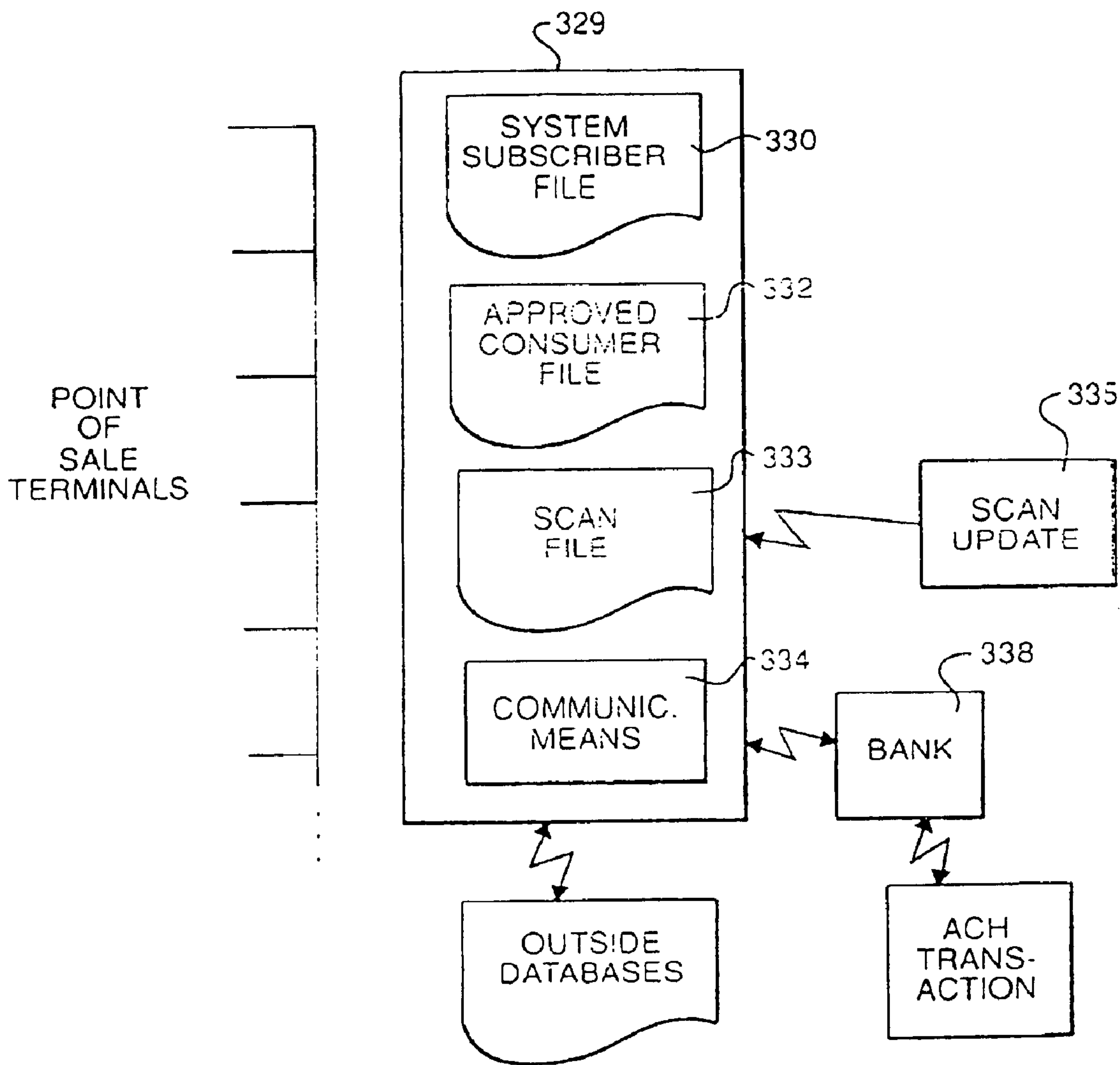

FIG. 3

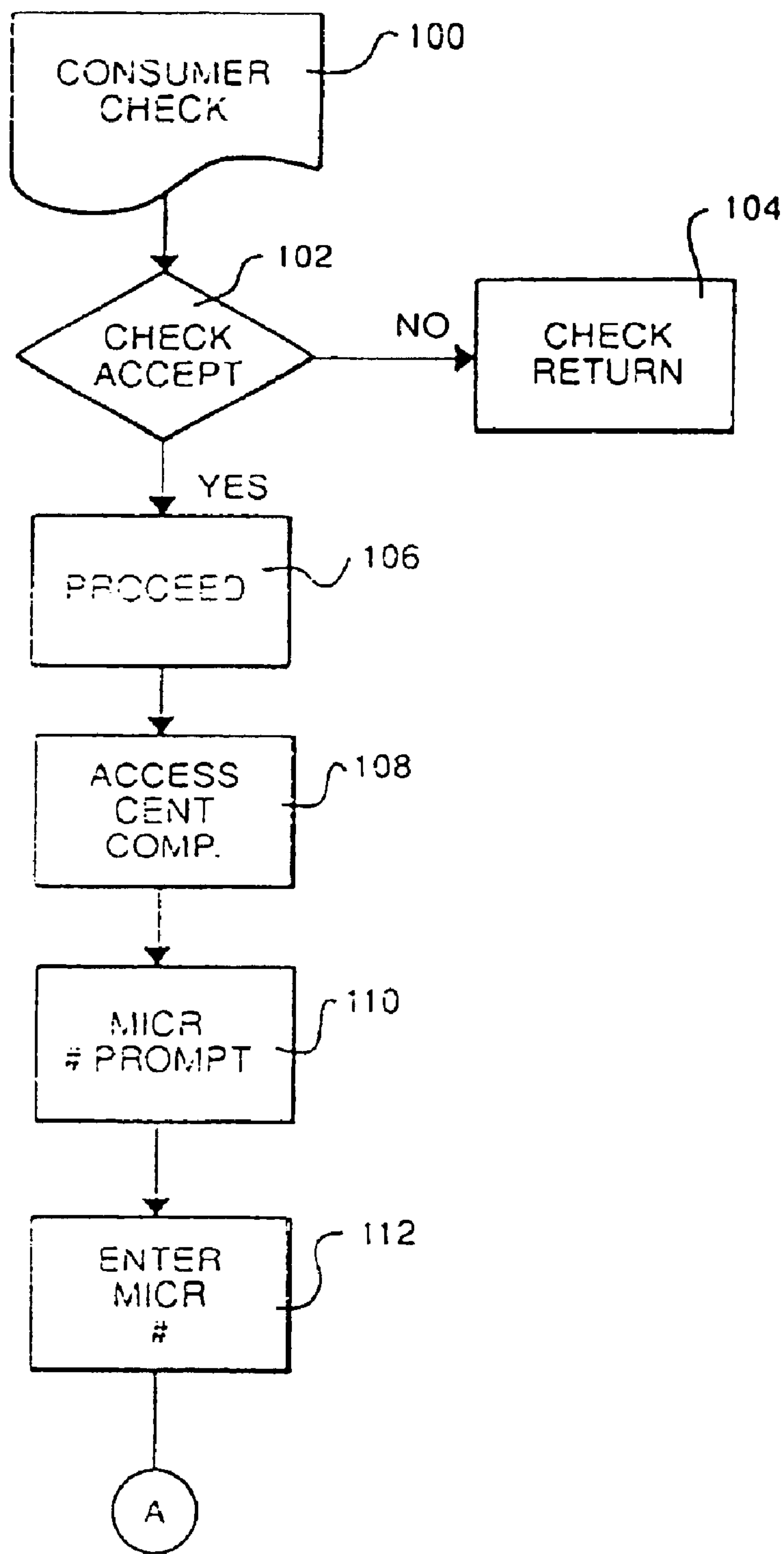

FIG. 4

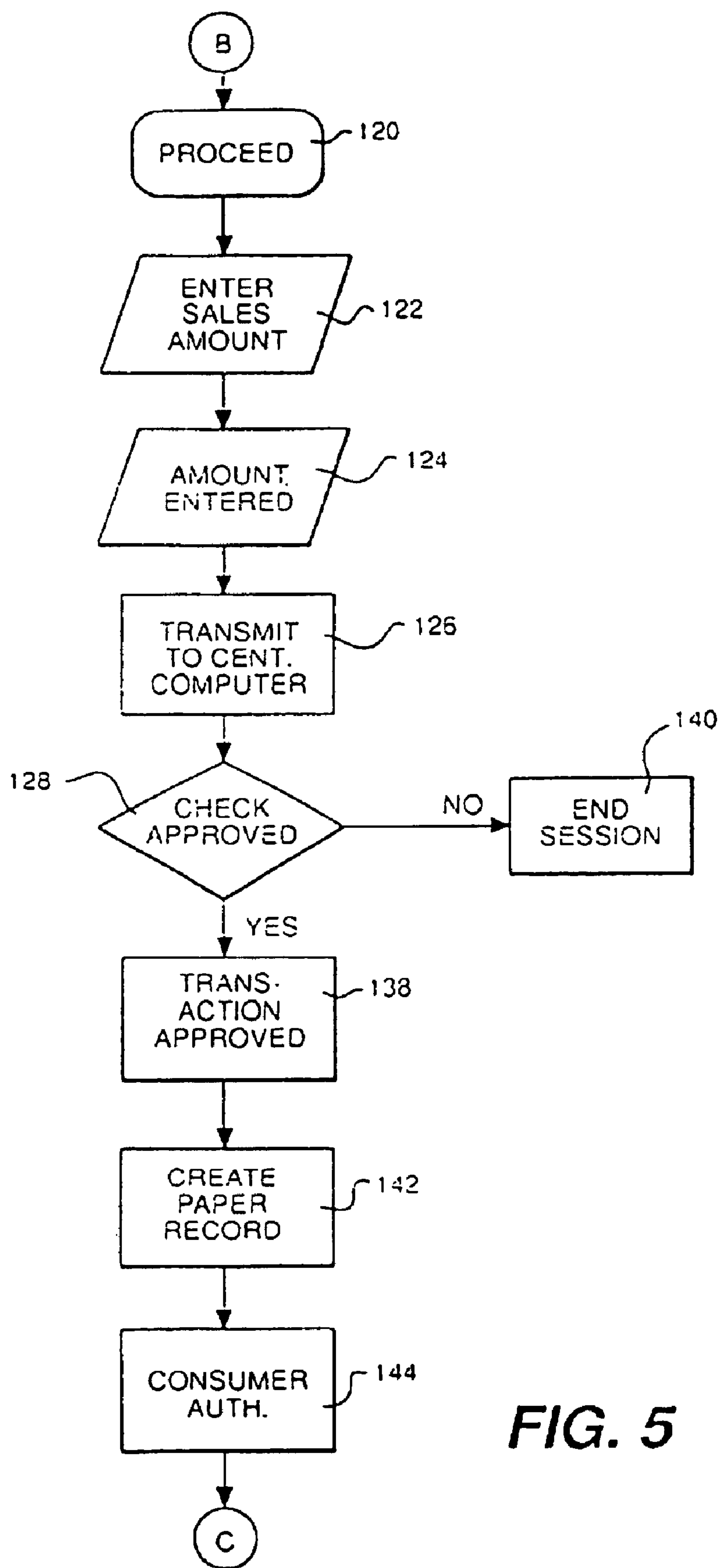

FIG. 5

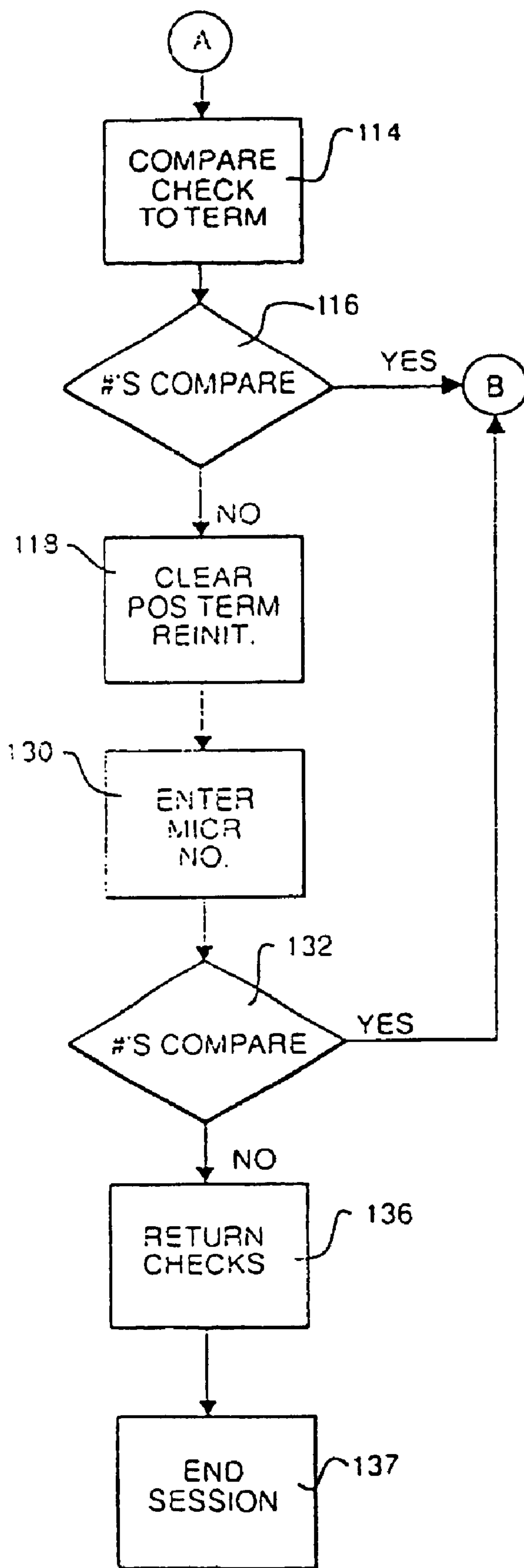

FIG. 6

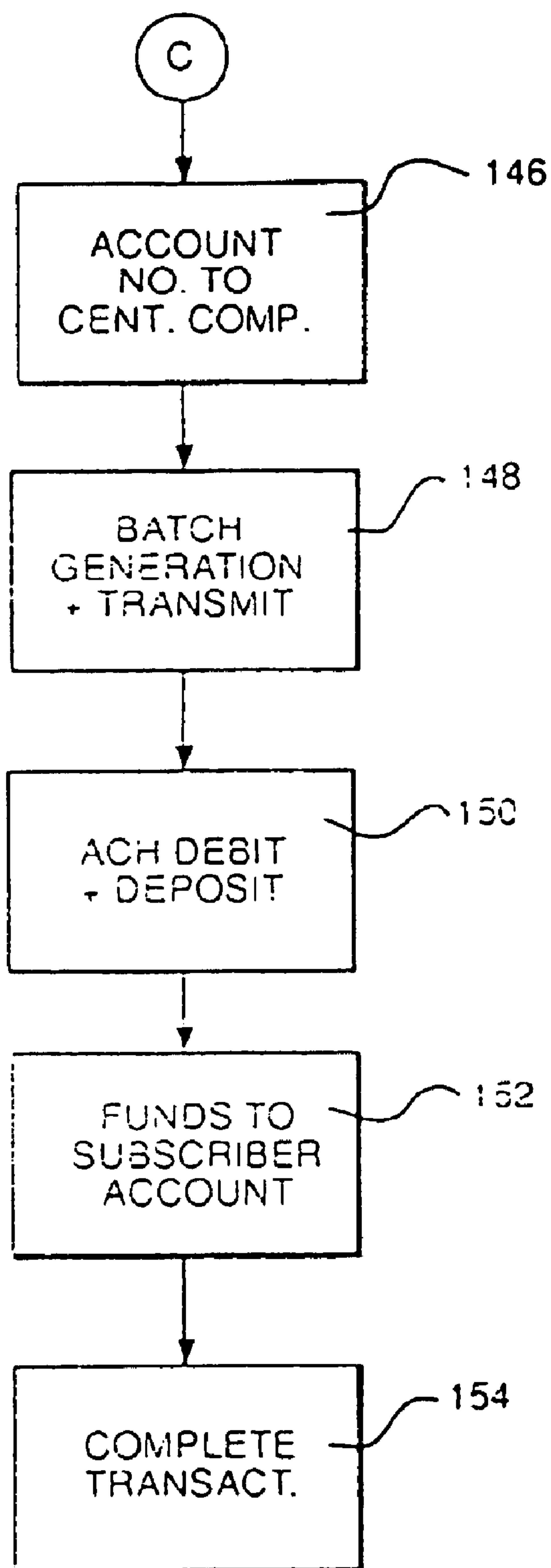

FIG. 7

Merchant Name
Street Address
City, ST Zip
Merchant Acct #

CUSTOMER BANKING INFORMATION:

BANK ACCT. NO. _____

TRANSIT NO. _____

SALE AMOUNT \$ _____

I herewith authorize ChequeMARK Systems to electronically access my designated checking account for the payment of the above referenced purchase amount. I acknowledge that sufficient funds are available for the payment of this sale.

Name (PRINT) _____

Street _____

City _____ ST _____ Zip _____

Tel. Number: (_____) _____ - _____

I FURTHER ACKNOWLEDGE THAT RETURN FEES WILL BE IMPOSED SHOULD MY PAYMENT BE DISHONORED AND UNDERSTAND THAT IT IS UNLAWFUL TO AUTHORIZE PAYMENTS FOR WHICH ADEQUATE MONIES ARE NOT AVAILABLE WITHIN MY ACCOUNT.

X _____

Authorizing Signature

FIG. 9

CHECK WRITING POINT OF SALE SYSTEM

Matter enclosed in heavy brackets [] appears in the original patent but forms no part of this reissue specification; matter printed in italics indicates the additions made by reissue.

RELATED PATENTS

This application is a continuation of application Ser. No. 09/851,609 filed on May 9, 2001, now U.S. Pat. No. 6,354,491, which is a divisional of application Ser. No. 09/562,303, filed on May 1, 2000 now U.S. Pat. No. 6,283,366, which is a continuation of application Ser. No. 08/775,400, filed on Dec. 31, 1996, now U.S. Pat. No. 6,164,528.

FIELD OF THE INVENTION

This invention relates to the field of Point-of-Sale systems and more particularly to the integration and processing of purchases whereby a check or encoded card is used as the basic source of identification of the individual and of the individual's bank and whereby the bank account is debited electronically.

BACKGROUND ART

Numerous devices exist for processing checks. For example, U.S. Pat. No. 4,933,536 to Lindemann, et al., describes a check processing device which is used together with a Point-of-Sale terminal. This particular device involves copying and taking a picture of an individual whereby a dishonored check could then be traced to the person who has offered it.

U.S. Pat. No. 4,810,866 to Lloyd, Jr., describes a check validation system again located together with a Point-of-Sale system for imprinting and otherwise physically dealing with a check.

Other systems also deal with an apparatus for handling checks at a point of sale. For example, U.S. Pat. No. 4,743,743 to Fukatsu describes one such transaction apparatus where a check is examined by a reader. U.S. Pat. No. 4,672,377 to Murphy, et al. describes a check authorization system wherein a check is imprinted with a bar code and information concerning customers which are stored in a database. U.S. Pat. No. 3,845,470 to Schuller discloses a vending system using a modified form of a check which is imprinted with identification codes, when someone attempts to use the check in purchasing goods and services, a vending operation will not place the order if information associated with the check is not valid in a particular database.

Other check-based financial systems have also been the subject of invention. U.S. Pat. No. 4,617,457 addresses an ATM or automatic teller machine form of cashing checks. Such systems create a picture of the check involved and also involves checking against a specialized database to insure that the check is a "valid" one (see also U.S. Pat. No. 4,580,040 to Granzow et al.).

Another generic category of financial systems deals with methods of handling the financial transactions apart from the physical handling of the check itself. For example, U.S. Pat. No. 3,824,544 to Simijian describes a merchant issued "check" which can be used in the purchase of goods and services and upon purchase, a specialized code is evaluated to determine if the check is being validly utilized.

U.S. Pat. No. 4,404,649 to Nunley et al. describes a document processing system which generally discloses a

method of reading checks for processing a wide variety of financial documents.

U.S. Pat. No. 4,523,330 to Caine also describes a method for processing financial documents which systems also includes a Point-of-Sale terminal for generating image data from checks as they are being processed. This patent is drawn principally to the actual terminal itself.

U.S. Pat. No. 4,673,802 to Ohmae et al. describes a central processing system having stored data relating to the counts of users. Users are approved or disapproved at the Point-of-Sale based upon information in the database.

U.S. Pat. No. 4,270,042 to Case discloses a point of sale system that requires a consumer to prepay a sum of money into a special account that is accessed only by the system. This amount is inscribed on the card, and when a transaction made using the system, the amount of the transaction is punched out of a designated area on the card. This amount along with a signature and other information, is supplied on a draft negotiable instrument, which is given to the merchant at the time of the transaction. Thus, the Case system does away with the use of bank checks in effecting the transaction, but requires the use of specialized prepaid draft negotiable instruments that must be surrendered to the merchant.

U.S. Patent No. 4,823,264 to Deming discloses a home banking system that can be used to transfer funds to different payees in satisfaction of debts incurred through previous purchases, use of utilities, etc. The system is consumer driven; that is, it is contemplated for use by the payor on a home personal computer. While the Deming system does away with the use of bank checks, account and other information must be keyed into the system. The Deming system cannot be used to read account and other information directly from an ordinary bank check and has no use for bank checks as instruments other than negotiable paper. Further, the Deming system cannot be used to transfer funds at the time of purchase and is not workable at the point of sale; the system can only be used to pay debts that have been incurred in the past and have accumulated.

Finally, U.S. Pat. No. 4,678,896 to Carlson et al. describes a Point-of-Sale system whereby an apparatus is provided to secure the processing and imprinting of checks.

All of these above patents deal with the specific problem of how to accept a check from a customer for the purchase of goods and services. They do not in any way address the subsequent processing of checks nor do they address the process by which checks are cleared through the normal automatic check handling clearinghouse operations that exist in the financial world. Thus, the interaction of these systems with the automated clearing house ("ACH") process is not addressed in any way. This is particularly important since if any Point-of-Sale check handling system is to interact with the ACH mechanism it must adhere to that processing scheme and must lend itself to use with a processing scheme.

Further, some of the currently used systems described above require the use of a bank check as a negotiable instrument which must be surrendered to a merchant. Some of the systems do away with the use of a bank checks altogether, but require a debit card or a specialized draft instrument to be used only with the particular system. None of these systems completely does away with the need and use for a negotiable draft instrument while using the consumer's bank check for identification and verification only. That is, current technologies such as check truncation, electronic check presentment and representment all require

a consumer's initial issuance of a "paper" check. It is therefore an objective of the present invention to provide such a system.

It is an objective of the present invention to be adaptable for use with the ACH system and to be smoothly incorporated into it. In this fashion, the present invention will immediately be useful for a much wider range of financial transactions above and beyond those contemplated and disclosed in the background references discussed above.

SUMMARY OF THE INVENTION

The present invention comprises a process and apparatus which may be employed for the purpose of effecting payments for point-of-sale purchases of goods and services paid from consumer funds secured in bank checking or depository accounts. Each sale of "Transaction Event" would be an electronic and "paperless" event thereby eliminating reliance on accepting and processing commercial bank drafts (personal or corporate checks) and the physical handling of those bank drafts thus replacing commercial bank drafts at the point-of-sale.

In contrast to known systems, the present invention is a merchant driven system that can be used to process a transaction at the point of sale and at the time of purchase. The system is intended to be made available to subscribing merchants, businesses, and individuals herein referred to as "system subscribers" wishing to employ the method and apparatus of the present invention for the electronic processing and settlement of consumer purchases. Further, operational parameters of the present invention allow freedom from customary state or other geographically limiting criteria typical when accepting and processing "paper" checks. The system is designed to act with the national authorization networks and the electronic settlement network known as the ACH system as regulated by the National Automated Clearing House Association ("NACHA") or other comparable systems including but not limited to ECCHO, the Cactus Switch, First Tennessee Bank, regional networks, the VISA network, and others. The present invention contemplates Transaction Events processed in a manner hereinafter referred to as "Electronic Checks" or "Electronic Checking."

The system is designed to perform in a fully automated manner enabling each Transaction Event to be processed by a system subscriber as a point-of-sale transaction in the presence of the consumer. Subsequent to a Transaction Event's being "Approved", funds are debited from an authorized consumer account for credit to the system subscriber, and electronic settlement by ACH deposit of the transaction amount to the subscriber's designated depository account. Authorized access to consumer accounts and credits to system subscriber depository accounts are performed as "Off-Line" transactions by means of Electronic Funds Transfer ("EFT") through the ACH Network or through the Federal Reserve System. "On-Line" transactions are also contemplated by the present invention once national networking and other present and proposed support mechanisms have become functional.

The present invention comprises a point-of-sale processing system having electronic data processing equipment which supports various individual service selections or transactions types each of which provide automated, electronic processing from consumer bank checking or depository accounts in payment of goods or services incurred at a system subscriber's point-of-sale. It is the objective of the present invention to automate the point-of-sale environment

for processing consumer purchases of goods and services would customarily necessitate the more traditional acceptance and processing of commercial bank drafts (personal and/or corporate checks). Individual Transaction Events are administered under the system of the present invention by initiating a terminal authorization inquiry and continuing through the electronic settlement of funds representing the Transaction Event. As a result of the above procedure, approved consumer banking accounts are debited and system subscriber's designated depository accounts are credited.

It is a further objective of the present invention to eliminate the need for "paper" checks as an accepted means of consumer payment. In the place of personal and business checks, consumers would be provided greater access to funds secured in bank accounts to effect purchases initiated from the point-of-sale. System subscribers electronically communicate with the data center of the present invention for individual Transaction Event authorizations which, upon reconciliation of a day's activity, result in an EFT processed by means of the Automated Clearing House accommodating an "Off-Line" or "On-Line" debiting of preauthorized consumer Transaction Events from approved accounts. Thereafter, each system subscriber is credited with the total of all such daily authorized Transaction Events to its designated bank depository account. The present invention also accommodates paper transactions as requested by the subscribing merchant or consumer. By way of example, transactions can be supported where the consumer prepared a "paper" check. The transaction would proceed in a fully electronic manner with the consumer retaining the "paper" check as an additional receipt.

The present invention comprises logic which allows the following services each of which, when individually performed or are combined with other services, establish a wholly unique processing medium enabling preauthorized access to consumers' checking account or bank depository reserves in payment of and settlement for purchases conducted from a system subscriber's point-of-sale.

Authorization—This service supports electronic communication from point-of-sale to the system's central computer. The data center stores positive and negative files concerning consumer accounts thereby providing accurate inquiry responses regarding the current posting status of a consumer's banking account and signaling the system subscriber that said account may be reasonably relied upon for consummating a Transaction Event (i.e., an "Approval") or, here listed as delinquent, indicating that the account may not be so relied upon (i.e., a "Denial"). The system also contemplates "On-Line" services that would also permit Fund Verification.

Check Replacement—This capability operates as an extension of Authorization enabling the system subscriber the capability of completing a Transaction Event by electronically logging the sale whereupon a Transaction Event slip will be printed or manually prepared for consumer execution at the point-of-sale. By execution of the Transaction Event Slip, the consumer authorizes the electronic processing of funds secured in his/her authorized banking count in lieu of the more traditional method of issuing personal and business checks. Funding settlement to the system subscriber would be effectuated by means of Electronic Funds Transfer via ACH, the Federal Reserve system or other competing facility as opposed to physically processing and transferring checks among banks. If preferred or requested by the subscribing merchant, the present invention would further allow for a consumer's check to be written and

5

thereafter voided, canceled, and returned to the consumer, or, in the alternate, submitted to lock box or similar storage facilities.

Bank Transaction Card—As part of this invention an “Off-Line” Debit Card is established on which is stored the information relating to the banking account from which funds representing the Transaction Event would be debited for payment to the system subscriber. This information may be stored on the card itself in encrypted or unencrypted form or may be stored in the central computer where access to such information is gained via special control characters or access codes stored on the card. Electronic authorization for withdrawal of funds from the cardholder’s account and subsequent electronic settlement procedures remain essentially identical to processing under the Check Replacement service described above. Information relating to the consumer-cardholder and the appropriate banking account to be debited for a Transaction Event will be encoded upon the Magnetic stripe portion of the plastic, and terminal-readable, card. The present invention is also compatible with SMART card technology.

Thus, the overall objective of the present invention is to provide and support an alternate means for consumer payments for goods and services that operates to replace commercial bank drafts in the point-of-sale environment. Simultaneously, the present invention assures consumers greater access to and use of funds in personal or corporate banking accounts. Further, the system provides system subscribers a significantly improved prospect of collecting the underlying monies for Transaction Events, reduced time for collecting the cash receipts from Transaction Events, and a pronounced lowering of the present cost of cumbersome procedures otherwise mandated by the existing mechanisms for accepting and processing commercial bank drafts.

A further objective of the present invention is to significantly reduce the use of checks as negotiable instruments in effecting the purchases of goods or services and to provide the system’s Electronic Checking Service as an equitable alternative for the consumers reliance on credit cards or cash.

DETAILED DESCRIPTION OF THE PREFERRED EMBODIMENT

The method of the present invention begins with the electronic capturing of consumer information at a system subscriber’s location using a point-of-sale terminal and related equipment. This information is obtained in the presence of the consumer and occurs prior to any “Approval” for the Transaction Event or for the ultimate crediting of the System subscriber’s designated depository account.

A Transaction Event involves a series of events initiating with a system subscriber’s intent to sell goods or services, the payment for which would be funds secured in a consumer’s banking account. The consumer’s banking account status would first be verified by accessing the central computer files of the present invention. Verification is performed by use of an encoded, magnetic stripe card, where presented by the consumer or by input of account numbers from a consumer’s specimen check. The present invention also contemplates compatibility with “SMART card” technology, whereby a consumers “ChequeMark Card” information might co-exists with other consumer data or payment options for alternate verification purposes. In addition to verifying a consumer’s account, a more traditional identification of the consumer could also occur including visual examination of driver’s license or similar and acceptable

6

picture “ID”, however, this is not considered part of the present invention.

For improved identification, security, and fraud purposes, the system is further capable of receiving input of a consumer’s Social Security Number and retaining the same for use in the approval and settlement processes. The present invention is also capable of validating a Social Security Number, screening out those numbers issued to individuals reported as deceased, and cross-searching the “known” (“Positive”) checkwriter database to verify the status of all banking accounts. Cross-searching is seeking a match of the Social Security Number with any over account on which there is a return, including the account which is the subject of the current inquiry. If preferred or requested by either a subscribing merchant or the affected consumer, the consumer’s check could be written and, subsequent to processing through the system of the present invention, marked as “Voided” or “Electronically Settled” and returned to the consumer. In the alternative, the consumer’s check may be submitted to a lock box or other storage facility.

As an integral portion of each Transaction Event, the system subscriber’s location, date and time, and requested sale amount is automatically logged into the system when a system subscriber first accesses the invention. Finally, a Transaction Event Slip (“Sales Slip”) will be produced by a printer integral to the point-of-sale terminal and will be executed by the consumer in the amount of the stated purchase with inscribed language defining the Transaction Event and specifically providing consumer authorization for electronic access to his/her banking account. The consumer’s specimen check is returned unused or, where written, is returned to the consumer as a receipt. Thereafter, the consumer account will be debited and the proceeds credited to the system subscriber’s designated depository account along with all other similar Transaction Events representing the total of the system subscriber’s daily activity. Debiting of consumer accounts and settlement deposits to each system subscriber is performed by means of Off-Line electronic funds transfer through an by the ACH or Federal Reserve System. Other competing facilities such as, but not limited to, ECCHO, Cactus Switch, First Tennessee Bank, regional networks, or the VISA network, could also utilized by the present system. The system has the further ability to convert settlement processing to an “On-Line” format which would involve services such as “Funds Verification” (Authorization) or “Reserving of Available Funds” or a combination of both.

Equipment Configuration—The present invention can operate with nearly every conceivable point-of-sale equipment system. The central computer system accepts data transmitted from the system subscriber’s existing point-of-sale equipment or that which is added to augment service performance. The point of sale terminal of the present invention is implemented in a number of ways, most preferred, however, being activated under a fully automated format. Such a fully automated system generally comprises a dual-port terminal with magnetic stripe reading capabilities interfaced with a logging printer capable of providing individual Transaction Event Slips for consumer execution, and a MICR check reader, optical character recognition (“OCR”) equipment, or other device. It is contemplated that services may also in the future be administered using the present invention with a singular point-of-sale hardware device which, as a function of its design, would incorporate all or most of the service capabilities of an integrated terminal, logging printer, and MICR Check Reading device. The present invention also anticipates supporting existing

point-of-sale equipment primarily dedicated to bankcard (“credit card”) processing and other equipment. Therefore, service subscriber activations may be supported under numerous means of access from the point-of-sale. For example, personal computers and electronic cash registers in addition to variations of the more traditional stand alone transaction processing equipment including alternate POS terminal processing equipment such as International VeriFACT and Hypercom, among others, are contemplated for use by the present invention. Additionally, the present invention can be interfaced with network computers, commonly referred to as “NC’s”. NC’s are lower end computers for the limited use of Internet access which are easily adapted for POS Electronic Checking and other money transfers anticipated by the present invention.

Communications links from point-of-sale terminals to the central computer of the present invention will typically be in the form of telephonic network communications over a public switched telephone network (“PSTN”) or over other approved networks. Internet access is also supported by the present system where access is deployed at a merchant POS for consumer payments. Internet access may also be utilized to process Electronic Checking inquiries from points other than the POS to conduct Transaction Events under the present invention between the merchant and the consumer as a merchant-initiated payment option. As the use of personal computers become more prevalent at the POS, utilization of the Internet to interconnect for approvals and capture for settlement of Electronic Checking events between a system subscriber and an affected consumer will become more routine. Transaction Event verification will occur as a result of point-of-sale terminal access to the Central computer’s positive and/or negative data files. “Approved” or “Declined” notifications are returned to the “Point-of-Sale” device over the PSTN. All data files will be centrally located and maintained on the invention’s central computer databases. Portions of the database include, but are not limited to, third party data files such as the Shared Check Authorization Network (“SCAN”) (trademark) database.

Individual transactions or groupings of transactions are first approved by soliciting an “Authorization” prior to capturing a Transaction Event for electronic funds transfer. To maintain an accurate status of file information for authorization to subscribing merchants, businesses, and/or individuals, the system is comprised of three separate but interactive databases, including a “Merchant,” “Checkwriter,” and “Transaction” database, which are continuously maintained. The “Merchant” database stores records of all service subscribers authorized to initiate Electronic Checking requests. These records include amongst others, authorization and initiation codes, as well as the system subscriber’s name and address. The “Checkwriter” database is a database of “Known” users. This database stores information that includes, amongst others, a status field indicating whether the Checkwriter would be “Approved” or “Declined.” Previously unseen Checkwriter MICR strings, when “Approved,” are also added to the “Checkwriter” database for future inquiries to the system. The “Transaction” database processes inquiries as well as stores the transaction records of “Approved” responses for formatting and electronic settlement through the ACH or similar facility. Current card holder or checkwriting records are updated daily and instantly available for point-of-sale inquiry for Transaction Event authorization.

System subscribers point-of-sale equipment is interfaced to the central computer of the present invention by means of a telephonic network which is able to support communica-

tion from a plurality of point-of-sale terminals. Programming of the point-of-sale terminal causes an automatic “Dial-Up” to the central computer and provides an automatic query and response sequence affirming or denying the Transaction Event. Each Transaction Event which is “Approved” is captured for electronic settlement within the transaction database log of the present system. The addition of local entry hubs may be installed to better facilitate the speed of economics of communications with the data files. Alternatively, the use of satellite or cellular communications or enhanced radio transmissions instead of telephonic networks may also be used. Similarly, the system’s data files and associated Check Replacement Service are contemplated to be responsive to emerging point-of-sale devices intended to seek authorizations and/or improved consumer identification and security by the alternate means of voice pattern recognition, POS fingerprint identification, retina scan, geometrics, biometrics, “smart” chips, consumer or check imaging and/or signature broadcasting. The present system further contemplates use of imaging technology as an enhancement to facilitate POS consumer identification and electronic settlement for “Approved” Transaction Events. Imaging technology comprises capturing an impression of a consumer’s check or a “signature capture” followed by electronic settlement of the consumer’s account.

The present system further comprises extensive system approval and fraud prevention capabilities. The system processes Transaction Events under a variety of different service types, each defined at the discretion of the system subscriber. The resulting flexibility enables the merchant to respond to his/her relative “comfort level” with a particular Transaction Event or consumer. Typical service types include (i) “Access Only” wherein the inquiry bypasses the present system’s approval criteria but the Transaction Event, including all consumer account information, is automatically captured and logged within the transaction database for an electronic settlement attempt; (ii) “Check Replacement” which seeks the systems transaction “approval” and, where “Approved”, captures the Transaction Event for electronic settlement; (iii) “Card Acceptance” which operates in a manner virtually identical to “Check Replacement” as mentioned above, but the Transactions Event is activated through the use of an encoded card (versus a specimen check); or (iv) “Authorization Only” which seeks the system’s approval providing a system subscriber information regarding the reliability of a subject consumers account, but does not capture the Transaction Event for electronic settlement. In the “Access Only” service type, “Access Only” events bypass the database records and all other approval and search criteria such as those explained below, e.g., velocity controls, social security checks, and scans. It is contemplated that these “Access Only” events always be “Approved” and passed immediately to a settlement log for an attempted consumer debit and service subscriber credit.

The present invention has the additional capability to use a consumer’s Social Security Number to perform a variety of identification and fraud preventative applications prior to issuing an “Approved” message for the Transaction Event. These include searches employing Social Security Number first to validate the consumer’s Social Security Number as a genuinely issued number. Second, the system cross searches the system’s “Dead File” to screen out Social Security Numbers which, while validly issued, were issued to individuals now reported as deceased. To a greater extent, verification and “Dead File” searches deter access by consumers attempting to use false identification. Lastly, the present system utilizes Social Security Numbers to cross

search all "Known" checkwriter banking account records for negative information before issuing an "Approved" message for the subject Transaction Event. This capability more fully insulates the system and its system subscribers from abuse and susceptibility to repeat abusers who would commonly seek to process Transaction Events from a multiplicity of banking accounts.

Entry of a consumer's Social Security Number is performed by input of the number from the keypad of a POS terminal used to process Transaction Events. Alternately, the system also supports the use of a pinpad or similar device, interfaced with the POS terminal, for consumer entry of a Social Security Number. This capability supports a consumer's preference for complete privacy as to the entry of pertinent information. Consumers accessing the system by means of a previously issued encoded card will have already logged their Social Security Numbers onto the system's database, and, therefore, would not be required to re-enter their Social Security Numbers or other pertinent information.

The present invention is also equipped with velocity controls which regulate approvals within prescribed purchase limits imposed upon either the system subscriber or a consumer. The present invention has the further flexibility to differentiate between "first time" consumer usage and those limits otherwise assigned to "known" consumer accounts. Merchant variations in velocity limits can also be imposed depending upon the type, nature, and consumer purchasing statistics for a particular merchant category or location.

Inquiries seeking an "Approval" response for a Transaction Event which meets all other criteria of the system's approval process, including velocity controls, and when involving previously unknown banking accounts but carrying verified Social Security Numbers which have revealed no negative information following a cross search of the database and where the numbers are also not entries in the "Dead File", are "Approved". Consequently, each consumer's banking account and Social Security Number, along with other information, is automatically logged into the "Known" checkwriter database of the present invention at the time the "Approved" response is transmitted to the inquiring POS terminal. In addition to other identification and fraud preventative measures, the system's access to Social Security Numbers significantly improves settlement features relating to matters of proper authority when "Approved" and captured Transaction Events are transmitted to the consumer's financial institution for settlement in the form of electronic debit and credit notations.

The system further contemplates other fraud and enhanced identification capabilities. These include, but are not limited to, reliance upon such evolving technologies as fingerprint capture and analysis, signature capture and verification, imaging technology, retina scan, biometrics, and other forms of manners of improved identification practices as such either currently exist or as such may, upon further development, be readily integrated in to the system of the present invention.

BRIEF DESCRIPTION OF THE DRAWINGS

- FIG. 1—System overview of the present invention
- FIG. 2—The point-of-sale equipment
- FIG. 3—The Central Computer System
- FIGS. 4-7—The process Data Flow
- FIG. 8—transaction Event Sales Slip
- FIG. 9—manual Transaction Event Sales Slip

DEFINITIONS

For purposes of the description and claims relative to the system of the present invention, the following terms shall have the meanings set forth below. The following definitions are applied throughout this application.

Card Acceptance: A service sponsored by the present invention which enables an encoded card to be utilized to access the central computer and thereby denote the subject consumer banking account to be electronically debited in a point-of-sale Transaction Event.

Authorization Only: A service made available under the present invention as a convenience to its service subscribers where the subscriber can verify the current status of the subject consumer's account. In the preferred embodiment, these events are not captured for electronic settlement.

Check Replacement Service: This is a service sponsored by the present invention which enables a consumer's specimen ("paper") check to be utilized to access the central computer of the present system thereby denoting the consumer banking account to be electronically captured and settled by presenting a debit notation through the facilities of the ACH, or other competing service, for a purchase conducted from a system subscriber's point-of-sale.

Access Only: This is a service sponsored by the present invention which enables a consumer's specimen ("paper") check to be utilized to access the central computer of the system thereby denoting the consumer banking account to be electronically captured and settled by presenting a debit notation through the facilities of the ACH, or other competing service, for a purchase conducted from a system subscriber's point-of-sale.

Electronic Checking: This is a service sponsored by the present invention which collectively enables a system subscriber to electronically debit funds from the consumer's bank account and credit to those funds to the system subscriber's account utilizing various transaction methods and banking rules as envisioned above.

DESCRIPTION OF THE PRESENT INVENTION

Referring to FIG. 1 an overall schematic of the present invention is described. Point-of-sale terminals **300** communicate over normal PSTN telephone lines with a central computer system **302** which in turn communicates with a Banking institution **304** for purposes of debiting consumer accounts and crediting system subscriber accounts. The banking institution performs its function via normal automated clearing house ("ACH") transactions **306** or other competing facility as mentioned above. Alternatively, the system can automatically generate preauthorized drafts to debit consumer checking accounts where more expeditious in settling a particular Transaction Event. This manner of settlement particularly addresses the "first-time" consumer whose account might otherwise require prenotification preceding the processing of a "live" debit event. Prenotification is to become volitional in 1996 which, when effective, will minimize the present system's reliance upon or use of drafts as a mechanism for settling consumer payment requests.

Referring to FIG. 2 the point-of-sale equipment is described. The point-of-sale terminal comprises several different entry means. A key board **310** can be used to input consumer information manually, including both bank routing and consumer account information. The key board **310** allows the system subscriber to input information such as (i) electronic checking requests, (ii) a void procedure for

11

incorrect, returned, or canceled events, (iii) a preauthorization inquiry for the status of consumer accounts, and (iv) accessing system subscriber's daily activity reports. Alternatively a card reader **312** can be used whereby the magnetic strip on the card is ready by the point-of-sale terminal to obtain account information and finally a check reader **314** may alternately be included to read the MICR encoded bank and account numbers which appear on a consumer's specimen check as a substitute for either a specific card or key board input. These various input means provide information to a microprocessor **316** which comprises logic means **318**, memory means **320**, and communication means **322**. The logic means **318** comprises logic which allows the information received from the various input means to be processed and stored in the memory **320**. The logic means further drives a display **324** which provides a visual output of the bank and account numbers of the consumer for verification. The communication means **322** allows the subscriber terminal to communicate with the central computer **302** for purposes of processing the consumer's purchase. The communications means **322** is compatible with ECR and PC systems.

Referring to FIG. **3** the central computer system **329** is described. The central computer system receives input from a plurality of point-of-sale terminals which provide transaction information from a system subscriber and a consumer desiring to purchase goods or services. The central computer system comprises a system subscriber **330** file which is a file of those merchants who have elected to use the present invention for processing purchases. The system subscriber **330** comprises the "Merchant" database which, as previously stated, stores records of all service subscribers authorized to initiate Electronic Checking requests, including authorization and initiation codes, and the system subscriber's name and address. The central system also comprises known consumer file **332** which stores the account information and names of those consumers who have already been approved for purchases to take place through various input means. The consumer file **332** comprises "Check-writer" database. Additional databases are relied upon by the system which assist in approving consumer. Transaction Events including, but not limited to, the SCAN (Trademark) database, MOD-10 verification, Social Security Number database, and other proprietary screening criteria which serve to approve, decline, or reject, the latter serving to cancel those inquiries which are inaccurate, incomplete, or contain fraudulent data received by the central computer. The "Transaction" database is another such database provided by the system.

The system of the present invention further comprises a third database defined as a transaction database which stores all activity that is conducted between the plurality of terminals and the central terminals. Those inquiries captured for a settlement attempt are converted by the system for ACH file for preparation and settlement. Inquiries either "DECLINED" or for various reasons rejected are similarly retained by the transaction database. The "DECLINED" or other rejected inquiries are withheld from transfer for settlement.

The computer system also comprises a communications means **334**. The communication means is capable of communicating with other external, third party databases to allow the system access to review additional negative records regarding the consumers' banking account prior to issuing an "Approved" response. Once an "Approved" response is given for a Transaction Event involving a consumer banking account previously unknown to the

12

system, the newly "Approved" consumer record is automatically added to the system's checkwriter database. This new record allows for the entry of the consumer's new address and phone number information.

As presently configured the central computer **329** already houses the third party database known as the SCAN (trademark) database **333** resident on the central computer. Thus credit worthiness can be checked using all current database criteria searches, and further benefit by immediate access to the records from the SCAN (trademark) database. All databases, including proprietary databases and SCAN (trademark) databases, are updated daily.

The communication means **334** also transmits ACH files which are created by the system and communicated with a banking institution **338**, including instructions for the bank to debit the account of the consumer and credit the account of the system subscriber (merchant), with the amount of the purchase. These transactions are then settled via the "Off-Line" ACH transaction process. The system of the present invention also contemplates the use of "On-Line" settlements.

Referring to FIG. **4** the process begins by a consumer presenting an encoded card or a specimen or "blank" check complete with MICR number to the system subscriber (the merchant) **100**. The subscriber begins the process by first pressing the appropriate key on a terminal to select a particular service prior to accessing the host computer **108**. Thereafter the point of sale terminal prompts the system subscriber to enter the appropriate MICR number **110**. The system subscriber then enters the appropriate MICR number either manually or by passing the card through a magnetic stripe reader on the terminal or the specimen check through a check reader which determines the consumer's bank and account numbers **112**.

Referring to FIG. **6** the subscriber would verify that the numbers appearing on the terminal's display screen match the numbers on the encoded card or the MICR numbers on a consumer's check **114**. If the numbers do not compare with that of the terminal the system subscriber clears the terminal and begins the transaction process again **118**. If the process is to be reinitiated, the subscriber enters the MICR or card number(s) into the point of sale terminal **130**. Thereafter the system subscriber compares the numbers as before **132**. If the numbers compare to the system display **134** the process proceeds. If the numbers do not compare **136** the check or card is returned to the consumer and the process terminates **137**.

Upon a successful reading of a consumer's specimen check, the check is number embedded thereon id also captured and, once communicated to the System Central Computer, retained for future reference purposes or security matters, such as consumer inquiries or verification of proper authority. Access to the check number proves critical when performing a sequence review to resolve such matters.

Referring to FIG. **5**, if the verification process proceeds, the terminal next prompts the system subscriber to enter the amount of the sale **122** and other security or identification information required. The subscriber enters the amount of the sale along with requested information **124** and the terminal thereafter transmits an inquiry to the host database for verification **126**.

The check or card approval process next takes place **128**. If the inquiry is not approved by the central computer the terminal displays a message declining or rejecting the transaction **140**. Thereafter, printer record of the declined or rejected transaction is made for purposes of the system

subscriber **142** to comply with the Fair Credit Reporting Act and Regulation of the Board of Governors of the Federal Reserve System.

If the card or check is approved, the terminal displays a message noting the approval **138** and the specimen card or check is returned to the consumer. The printer further makes
5 may alternately be included to read the MICR encoded bank and account numbers which appear on a consumer's specimen check as a substitute for either a specific card or key board input. These various input means provide information to a microprocessor **316** which comprises logic means **318**,
10 memory means **320**, and communication means **322**. The logic means **318** comprises logic which allows the information received from the various input means to be processed and stored in the memory **320**. The logic means further drives a display **324** which provides a visual output of the bank and account numbers of the consumer for verification. The communication means **322** allows the subscriber terminal to communicate with the central computer **302** for purposes of processing the consumer's purchase. The communications means **322** is compatible with ECR and PC systems.

Referring to FIG. **3** the central computer system **329** is described. The central computer system receives input from a plurality of point-of-sale terminals which provide transaction information from a system subscriber and a consumer desiring to purchase goods or services. The central computer system comprises a system subscriber **330** file which is a file of those merchants who have elected to use the present invention for processing purchases. The system subscriber
25 **330** comprises the "Merchant" database which, as previously stated, stores records of all service subscribers authorized to initiate Electronic Checking requests, including authorization and initiation codes, and the system subscriber's name and address. The central system also comprises known consumer file **332** which stores the account information and names of those consumers who have already been approved for purchases to take place through various input means. The consumer file **332** comprises "Check-writer" database. Additional databases are relied upon by the system which assist in approving consumer Transaction Events including, but not limited to, the SCAN (Trademark) database, MOD-10 verification, Social Security Number database, and other proprietary screening criteria which serve to approve, decline, or reject, the latter serving to
30 cancel those inquiries which are inaccurate, incomplete, or contain fraudulent data received by the central computer. The "Transaction" database is another such database provided by the system.

The system of the present invention further comprises a
35 third database defined as a transaction database which stores all activity that is conducted between the plurality of terminals and the central terminals. Those inquiries captured for a settlement attempt are converted by the system for ACH file for preparation and settlement. Inquiries either "DECLINED" or for various reasons rejected are similarly retained by the transaction database. The "DECLINED" or other rejected inquiries are withheld from transfer for settlement.

The computer system also comprises a communications
40 means **334**. The communication means is capable of communicating with other external, third party databases to allow the system access to review additional negative records regarding the consumers' banking account prior to issuing an "Approved" response. Once an "Approved" response is given for a Transaction Event involving a consumer banking account previously unknown to the

system, the newly "Approved" consumer record is automatically added to the system's checkwriter database. This new record allows for the entry of the consumer's new address and phone number information.

As presently configured the central computer **329** already houses the third party database known as the SCAN (trademark) database **333** resident on the central computer. Thus credit worthiness can be checked using all current database criteria searches, and further benefit by immediate
5 access to the records from the SCAN (trademark) database. All databases, including proprietary databases and SCAN (trademarks) databases, are updated daily.

The communication means **334** also transmits ACH files which are created by the system and communicated with a banking institution **338**, including instructions for the bank to debit the account of the consumer and credit the account of the system subscriber (merchant), with the amount of the purchase. These transactions are then settled via the "Off-Line" ACH transaction process. The system of the present invention also contemplates the use of "On-Line" settlements.

Referring to FIG. **4** the process begins by a consumer presenting an encoded card or a specimen or "blank" check complete with MICR number to the system subscriber (the merchant) **100**. The subscriber begins the process by first pressing the appropriate key on a terminal to select a particular service prior to accessing the host computer **108**. Thereafter the point of sale terminal prompts the system subscriber to enter the appropriate MICR number **110**. The system subscriber then enters the appropriate MICR number either manually or by passing the card through a magnetic stripe reader on the terminal or the specimen check through a check reader which determines the consumer's bank and account numbers **112**.

Referring to FIG. **6** the subscriber would verify that the numbers appearing on the terminal's display screen match the numbers on the encoded card or the MICR numbers on a consumer's check **114**. If the numbers do not compare with that of the terminal the system subscriber clears the terminal and begins the transaction process again **118**. If the process is to be reinitiated, the subscriber enters the MICR or card number(s) into the point of sale terminal **130**. Thereafter the system subscriber compares the numbers as before **132**. If the numbers compare to the system display **134** the process proceeds. If the numbers do not compare **136** the check or card is returned to the consumer and the process terminates **137**.

Upon a successful reading of a consumer's specimen check, the check is number embedded thereon id also captured and, once communicated to the System Central Computer, retained for future reference purposes or security matters, such as consumer inquiries or verification of proper authority. Access to the check number proves critical when performing a sequence review to resolve such matters.

Referring to FIG. **5**, if the verification process proceeds, the terminal next prompts the system subscriber to enter the amount of the sale **122** and other security or identification information required. The subscriber enters the amount of the sale along with requested information **124** and the terminal thereafter transmits an inquiry to the host database for verification **126**.

The check or card approval process next takes place **128**. If the inquiry is not approved by the central computer the terminal displays a message declining or rejecting the transaction **140**. Thereafter, printer record of the declined or rejected transaction is made for purposes of the system

subscriber **142** to comply with the Fair Credit Reporting Act and Regulation of the Board of Governors of the Federal Reserve System.

If the card or check is approved, the terminal displays a message noting the approval **138** and the specimen card or check is returned to the consumer. The printer further makes a paper record of the transaction **142** and the consumer places any required information on the paper receipt and signs the receipt expressly authorizing the transaction **144**. At the election of the system subscriber, or at the request of the consumer, the consumer may write the check which would then be stamped "Void" or "Electronically Settled" and thereafter returned to the consumer or submitted to lock box or other storage facilities. This procedure is used for security measures or where fraud and/or database searches (which rely on the cancellation of a specimen check) are contemplated.

Referring to FIG. 7, the process description continues. Once the transaction is "Approved", the central computer makes a record of the MICR information and other data captured at the point-of-sale, including the sale amount, permanently storing all the information **146**. Upon closeout of a terminal's batch of daily Transaction Events by a system subscriber, the system's central computer reformats the captured activity within its transaction database to ACH format and thereafter, at regular intervals, transmits all of the daily batch activity for every system subscriber into the ACH network as debit and credit notations. The central computer subsequently generates a batch message regarding all Transaction Events for the prior period and transmits all the Transaction Event information for the day into the ACH network **148**.

During the ACH process each Checkwriter's account is debited for the exact purchase amount **150**. Thereafter, collected funds representing the total of a day's activity, being the aggregate of all Transaction Events processed for consumers by the system subscriber, are deposited into a subscriber's designated account **152**. The transaction is then complete **154**.

How to Use

The present invention will require the establishment and maintenance of three interconnected but separate data files for the purpose of performing access searches. The system embodied by the present invention, and the interactive databases comprising the system, are accessible by dial-up communication procedures from point-of-sale ("POS") terminal devices, electronic cash registers, and/or personal computers similar to the equipment utilized in the processing of automated bankcard ("credit card") receipts. The terminal prompts an operator/user to process one of four optional inquiry types. Any one or all of four primary functions are capable of being performed at a single point-of-sale terminal within the control of the system subscriber.

The inquiry types and database responses for "Approved" Transaction Events are as follows:

Card Acceptance—Having depressed the assigned key and thereafter being prompted, the system subscriber "slides" an encoded magnetic stripped transaction card through the point-of-sale terminal and enters the "Sale Amount" requested for authorization. Thereupon, the terminal's dial-up capabilities direct the inquiry to the central computer for authorization against "KNOWN" (Positive and Negative) file of current cardholders). Inquiries where a "POSITIVE" "Match" are found and where the cardholders' status fields are listed in "good standing" cause an "Approved" return message from the data file to the inquiring POS terminal. In order to accomplish this the present

invention's database captures each new MICR string for future reference. Embedded within the data record is a notation identifying the "Status" for that account. In this manner, if a certain signal is generated, for instance a "Y", then the account would be "Approved" for future access to the system. Conversely, a "No-Match" to inquiry or a "Match" where the cardholder's status field were listed in "bad standing" would result in a "Declined" notice to the POS terminal. Daily input to the system for the present invention causes automatic updating of status fields for all cardholder files including the activation of new cardholder accounts, the placement of corrective status entries ("Positive" or "Negative") into the status of existing cardholder files, deletion of terminated accounts or to change other file status in existing accounts. In the case of a "No-Match" the system of the present invention would generate a different signal such as a "No" and the "Account would be "Declined" upon an attempt to access the system.

Authorization Only—Having depressed the assigned key and thereafter being prompted, the system, subscriber manually enters account numbers from a personal or business check or, where fully automated, enters a specimen check through a MICR Check Reader device interfaced with the terminal, whereupon the terminal's screen would display the check's bank and account numbers for verification. Thereafter, the operator would enter the "Sale Amount" and other security or identification information requested for authorization. The terminal's dial-up capabilities then direct the inquiry to the computer data file center for authorization first against the "Known" file of checkwriting records whereupon the current status field is verified. A successful "Match" to an inquiry, where the current status field lists the checkwriter record as in "good standing", would result in an "Approved" notice from the central computer to the inquiring terminal. Conversely, a successful "Match" to an inquiry, where the current status field lists the checkwriter record as not in "good standing", would result in a "Declined" notice from the central computer to the inquiring POS terminal. Each inquiry preliminarily resulting in a "No-Match" (first time user) when processed against the system's "Known" checkwriter's database would then be passed through any and all available third party databases which reside on or are available to the system by external link preceding any return notice to the inquiring terminal. This third file is anticipated to be the Shared Check Authorization Network ("SCAN") a negative database currently maintained in the system computer data file center or other databases.

Check Replacement Service—Inquiries initiated as Checked Replacement inquiries are first processed through the system's "Known" checkwriter database and, as necessary, thereafter proceed to the SCAN database, or other database files, prior to the issuance of an "Approved", "Declined", or a rejection message to the inquiring POS terminal. A "Match" in the system's checkwriter database records indicates a consumer account which is "Known" to the system. If a "Match" is found and where the checkwriter's status field within the database is listed in "good standing", an "Approved" response results. Conversely, a "Match" where the checkwriter's status field were listed in "bad standing" would result in a "Declined" notice. Reliance upon account information available from SCAN or any other positive or negative databases minimizes the risk associated with the system's approval of Transaction Events involving consumer accounts which are previously "Unknown" to the invention's proprietary "Known" checkwriter database. A "Match" in the SCAN "NEGATIVE" file would result in a "Declined" response to the inquiring terminal. Where a "No

Match" should occur, and subject to the receipt of no other negative information received from the system criteria searches or from alternate databases, the event would be "Approved" as a "first-time" consumer user. Negative information received from SCAN or the rejection of the Transaction Event for other reasons would result in a "Declined" or one of various reject responses to the POS terminal. Daily input to the system of the present invention causes automatic updating of all checkwriter records and the placement of corrective entries ("Positive" or "Negative") into the status fields of existing checkwriter files. Each newly captured, but previously "Unknown" accounts, would, subsequent to an "Approved" notice, be automatically entered into the system's "Known" checkwriter file. Check Replacement Transaction Events are captured by the system and logged within its transaction database. The total of daily, "Approved" Transaction Events are "paperless" sales whereby the service subscribing merchant has submitted requests for electronic debit via the ACH network, or other competing facilities for each such authorized consumer purchase. Commercial bank drafts ("paper" checks) are not accepted or processed by the service subscriber. For each "Approved" Transaction Event, a "Sales Receipt" is manually prepared or is automatically printed at the point-of-sale. The consumer provides express authorization for an electronic debit by signing individual sales receipts.

Access Only—Access Only Transaction Events are processed in essentially the same manner as Check Replacement events with one significant variance. Access Only events bypass the authorization criteria within the system's central computers established for approving Check Replacement events and are automatically captured within the system's transaction database for a settlement attempt. All other functionality aspects of an Access Only and a Check Replacement Transaction Event remain identical.

All terminal programming and all prompts strings for MICR Check Reader interfacing are stored in the POS terminal and the computer center of the present invention controls interactions between the plurality of terminals and the central system. The following modules are present.

Programming for POS Equipment Interface—system subscriber locations to be activated with the present invention must possess or acquire a Tranz (trademark) 330 or higher grade terminal or alternate terminals, personal computers, or approved electronic cash registers supporting interface capabilities with a MICR check reader.

The MICR check reader interface results in the reading and transmitting to a terminal, in accepted format, of the consumer's entire ABA/Transit, checking account, and specific check number information which when combined with other data keyed directly into the terminal results in a query to the system's central computers. Subsequent to a terminal receipt of the banking account numbers, the terminal's will display the numbers on its screen allowing the operator to verify the accuracy of the captured "read" prior to proceeding. If the consumer's account numbers are correct, the Transaction Event may proceed, or, where incorrect, the operator can "clear" the event and resubmit the consumer's specimen check through the check reader. Alternately, the consumer's bank and account numbers and other requested information may be manually entered directly into the terminal with all other financial and operational advantages of the present invention remaining in effect.

The computer data file center receives and processes Transaction Event authorization requests utilizing the entire MICR string for accurate, error-free identification of both the consumer bank and a specific checking or depository

account to participate in a sale. ACH settlement criteria mandate exact recall for the bank and checking account numbers to properly complete any debit request. This invention conforms to each and every requirement of the ACH transaction regulations including all pending guidelines and/or proposals and rules changes regarding processing requirements or new classification or submittal types.

The present invention assigns a unique identifier(s) for purposes of accurately identifying individual MICR accounts and Transaction Events. To this end, each new event captured on the "Checkwriter" database is consecutively assigned a unique 15 character account number, checkwriter. This unique same checkwriter identifier is thereafter printed on future receipts for subsequent transactions processed.

Additionally, upon entry of media information from one receipt, an additional code, such as a sixteenth character, is automatically assigned by the present invention. The sixteenth character indicates that the subject MICR account is "known" and "registered" on the system, thereby alleviating the need to supply a Checkwriter's name, address, and phone number on subsequent transaction receipts.

A second unique identifier is assigned to distinguish an individual Transaction Event approved by the system. For purposes of settlement, or other inquiries, this numerical identifier may be employed to recover all salient information pertaining to the Transaction Event, Checkwriter, and the service subscriber. It is also contemplated that under certain circumstances, the check number can be used in lieu of a unique identifier to effect settlement and credit of the Transaction Event. Both identifiers (i.e., Checkwriter and event) are retained by the system and printed on the customer's transaction receipt. Moreover, the unique identifier's satisfy the requirements for the preparation and submittal of electronic debit and credit notations through the ACH in conformance with Federal regulations.

Each Transaction Event is completed with the logging printer generation of a Transaction Event ("Sales") Slip for each "Approved" authorization inquiry processed (FIG. 8). Alternatively, a manually created Transaction Event slip can also be prepared (FIG. 9). Each such Transaction Event Slip must be exacting in its retention of account numbers and the sale amount enabling both the consumer and system subscriber to be provided "hard copy" receipts of the event. Also included would be a clear printing of the transaction type; "Card Acceptance," "Authorization Only" (as appropriate), "Check Replacement," or "Access Only". Authorization language is printed immediately preceding the consumer's signature line specifically authorizing electronic access in payment of the requested transaction sale amount.

Instances will arise where previously "Approved" Transaction Events will require the operational equivalent of a "Void" or "Credit" procedure. The system of the present invention enables communication by a service subscriber with the central computers to effect such corrective adjustments to prior events. By way of example, a "Void" may be initiated by depressing the assigned key on a service subscriber's POS terminal and, once complying with security prompts, the POS terminal will thereafter communicate with the system's central computers and make such requested corrections. In the event of a "Voided" Transaction Event, a separate "Voided" slip will be automatically printed as a permanent record.

In addition to the primary functions for POS equipment programming, each POS terminal/MICR interface processing location is capable of generating printed activity reports.

Activity reports can be printed in either summary or detail formats identifying all "Approved" Transaction Events by service type, approval number, and amount. Reports further provide the total number of events "Approved" and the total captured amount of consumer payments contained within the activity report. Events which were previously recorded on the system's central computers as "Approved" but which have been subsequently "Voided" are also identified, including detail of the originally "Approved" events, with the amount of such "Voided" events deleted from the activity report's total for the captured amount for all Transaction Events.

SUMMARY

A flexible, transaction processing system is described which permits point-of-sale electronic checking events to be conducted in a "paperless" manner thereby eliminating the necessity of a service subscriber accepting or processing commercial bank drafts ("paper" checks) otherwise presented by consumer's in payment for goods or services. Individual Transaction Events are submitted to the system's database for approval in an automated manner and, where "Approved", captured for electronic settlement. Thus, consumer payments initiated from a service subscriber's point-of-sale are electronically debited against the banking account of the consumer and credited to the designated depository account of the service subscriber. Among the numerous advantages of the current invention, consumers are provided access to their banking account funds, but service subscribers are no longer required to accept or process commercial bank drafts ("paper" checks). Transaction Events captured by the system are settled electronically by the submission of credit and debit notations through the facilities of the ACH network or any competing network. Departures from the proposed system, especially with respect to modifications to the system's service types or the point-of-sale equipment employed, will be apparent to those skilled in the art without departing from the spirit of the invention as described. For example, variances in service type such as "ECK," "RCK," "Check Truncations," and "Electronic Check Presentment" which enables Electronic Checking events to be processed from a merchant's point-of-sale system are also contemplated by the present invention.

What is claimed is:

[1. A checkwriting system comprising:

- (a) a terminal adapted to receive consumer bank account information from any bank check;
- (b) the terminal further adapted to receive consumer bank account information from a consumer communicating with the terminal over the Internet;
- (c) a central computer system;
- (d) first communications means for electronic communications between said terminal and the central computer system;
- (e) second communication means for receiving information from a plurality of said terminals; and
- (f) the central computer system second communication means enabling said central computer system to communicate with external databases for performing a consumer bank account status search and further enabling automated clearing house communication for transferring funds without using the bank check as a negotiable instrument.]

[2. The checkwriting system of claim 1 wherein the terminal is further adapted to print activity reports of transaction events occurring at the terminal.]

[3. The checkwriting system of claim 1 further comprising means for biometrically verifying the identify of the consumer.]

[4. A checkwriting process comprising:

- (a) providing checking account information to a merchant or service provider;
- (b) storing the checking account information obtained;
- (c) providing transaction event information; and
- (d) transmitting the transaction event information for subsequent automated clearing house operations; wherein the checking account is debited for the transaction without using a check as a negotiable instrument.]

5. A method for electronic processing of consumer payment for goods or services comprising:

*receiving account information from a bank check;
receiving a transaction amount;*

*receiving authorization for an electronic funds transfer, the authorization being for the transaction amount;
transmitting the account information and the transaction amount;*

annotating the bank check; and

submitting the account information and the transaction amount for electronic settlement.

6. The method of claim 5, further comprising originating the electronic funds transfer after the bank check has been annotated.

7. The method of claim 6, wherein the electronic funds transfer is an ACH debit as payment for goods or services, the ACH debit replacing a transaction that uses a written bank check retained by a merchant for subsequent negotiation.

8. The method of claim 6, wherein originating the electronic funds transfer is the last step of the method.

9. The method of claim 5 wherein the authorization for an electronic funds transfer is received in written form.

10. The method of claim 9, wherein receiving written authorization comprises receiving a bank check bearing a consumer's signature and printing an electronic funds transfer notice on the bank check.

11. The method of claim 5 further comprising settlement of the consumer payment for goods or services through electronic funds transfer.

12. The method of claim 5 wherein receiving the account information is done by reading magnetic ink characters from the bank check.

13. The method of claim 5 wherein receiving the account information is done by imaging the bank check.

14. The method of claim 5 wherein receiving the account information and the transaction amount comprises imaging the bank check.

15. The method of claim 5 wherein transmitting the account information is done by transmitting an image of the bank check.

16. The method of claim 5 wherein receiving the account information is done by imaging the bank check and wherein transmitting the account information is done by transmitting an image of the bank check.

17. The method of claim 5 wherein annotating the bank check comprises marking it "void".

18. The method of claim 5, further comprising storing the account information and the transaction information.

19. The method of claim 5, wherein receiving authorization comprises receiving the consumer's signature for electronic funds transfer.

21

20. The method of claim 19, further comprising:
 a. comparing at least part of the account information with data in at least one database; and
 b. making a transaction authorization decision based on the comparison.

21. The method of claim 19, further comprising receiving merchant data from any one of multiple, unrelated merchants.

22. The method of claim 21, wherein the merchant data is compared to data in a merchant database comprising information regarding multiple, unrelated merchants that are authorized to use the method.

23. The method of claim 22, wherein the electronic funds transfer is an offline ACH debit, the offline ACH debit replacing a transaction that uses a written check retained by a merchant for subsequent negotiation and being initiated without human intervention.

24. The method of claim 23, wherein the merchant data is compared to data in a merchant database comprising information regarding multiple, unrelated merchants that are authorized to use the method.

25. The method of claim 24, wherein the electronic funds transfer is an offline ACH debit, the offline ACH debit replacing a transaction that uses a written

26. The method of claim 5, wherein receiving authorization comprises receiving a bank check bearing a consumer's signature and printing an electronic funds transfer notice on the bank check.

27. The method of claim 26, further comprising:

a. comparing at least part of the account information with data in at least one database; and

b. making a transaction authorization decision based on the comparison.

28. The method of claim 27, wherein the at least one database comprises a checkwriter database.

29. The method of claim 28, further comprising receiving merchant data from any one of multiple, unrelated merchants.

30. The method of claim 29, wherein the electronic funds transfer is an offline ACH debit, the offline ACH debit replacing a transaction that uses a written check retained by a merchant for subsequent negotiation and the offline ACH debit being initiated without human intervention.

31. The method of claim 26, further comprising receiving merchant data from any one of multiple, unrelated merchants.

32. The method of claim 31, wherein the merchant data is compared to data in a merchant database comprising information regarding multiple, unrelated merchants that are authorized to use the method.

33. The method of claim 32, wherein the electronic funds transfer is an offline ACH debit, the offline ACH debit replacing a transaction that uses a written check retained by a merchant for subsequent negotiation.

34. The method of claim 33, wherein the merchant data is compared to data in a merchant database comprising information regarding multiple, unrelated merchants that are authorized to use the method.

35. The method of claim 34, wherein the steps of submitting the account information and the transaction amount for electronic settlement are done without human intervention.

36. A method for electronic processing and settlement of consumer payment for goods or services:

reading preprinted account information from a bank check drawn on an account, the preprinted account information comprising a routing number, an account number, and a bank check serial number;

22

receiving a transaction amount;

transmitting the account information and the transaction amount;

receiving written authorization for electronic funds transfer debit in the transaction amount through an electronic settlement network selected from the group comprising national authorization networks and regional authorization networks;

receiving an approval for the debit based on the status of an account on which the bank check is drawn;

annotating the bank check by printing "void";

returning the annotated bank check to a consumer;

printing a receipt for the debit; and

originating the debit for the purchase of goods or services, the debit replacing a transaction that relies on presentment of a written bank check.

37. The method of claim 36 wherein the written authorization for electronic funds transfer comprises a signed authorization by the consumer.

38. A method for a transfer of funds from a consumer account that eliminates presentment of a bank check for payment, the transfer based on electronic fund transfer authorization, the method comprising:

receiving, at a central computer, account information from a bank check after account information is derived from the bank check at a system subscriber's terminal;

receiving, at the central computer, a transaction amount after the transaction amount is entered into the system subscriber's terminal; and

transmitting an authorization message to the system subscriber's terminal, the authorization message causes the printing of the electronic fund transfer authorization at the system subscriber's terminal, and an annotation on the bank check.

39. The method of claim 38 wherein the transfer of funds is processed through an electronic settlement network selected from the group comprising national authorization networks, regional authorization networks, and ACH network.

40. The method of claim 38, further comprising:

a. comparing at least part of the transaction information with data in at least one database; and

b. making a transaction authorization decision based on the comparison.

41. The method of claim 40, wherein at least one database comprises a checkwriter database.

42. The method of claim 41, further comprising updating the checkwriter database with at least part of the transaction information.

43. The method of claim 40, wherein the at least one database comprises a merchant database comprising information regarding multiple, unrelated merchants that are authorized to use the method.

44. The method of claim 40, further comprising updating a transaction database with transaction records for ACH processing.

45. The method of claim 38 wherein receiving account information comprises reading magnetic ink characters from the bank check.

46. The method of claim 45 wherein the account information comprises a routing number, an account number, and a bank check serial number.

47. The method of claim 38 wherein receiving the account information comprises imaging the bank check.

48. The method of claim 38 comprising transmitting an image of the bank check for processing through an electronic settlement network.

49. The method of claim 38 wherein receiving the account information is done by imaging the bank check and comprising transmitting an image of the bank check for processing through an electronic settlement network.

50. The method of claim 38 wherein the electronic fund transfer authorization is in written form comprising signature of the consumer.

51. The method of claim 38, further comprising receiving merchant data from any one of multiple, unrelated merchants.

52. The method of claim 51, wherein the merchant data is compared to data in a merchant database comprising information regarding multiple, unrelated merchants that are authorized to use the method.

53. The method of claim 52, wherein the electronic funds transfer is an offline ACH transaction.

54. A method for authorizing the debit of funds from a consumer account, the authorization based on a signed electronic fund transfer authorization agreement, the method comprising:

receiving, at a central computer, account information from a bank check after account information is derived from the bank check at a system subscriber's terminal, the account information comprising a routing number, an account number, and a bank check serial number;

receiving, at the central computer, a transaction amount after the transaction amount is entered into the system subscriber's terminal;

receiving transaction information from a checkwriter database;

making a transaction authorization decision based on the transaction information;

transmitting an approval message to the system subscriber's terminal, the approval message resulting in the printing of the electronic fund transfer authorization agreement at the system subscriber's terminal, and an annotation on the bank check; and

updating a transaction database with transaction records for processing through an electronic settlement network.

55. The method of claim 54 wherein the electronic settlement network is selected from the group comprising national authorization networks, regional authorization networks, and ACH network.

56. The method of claim 54 wherein the signed electronic fund transfer authorization agreement comprises a signed bank check with an electronic funds transfer authorization printed on the bank check.

57. The method of claim 54 wherein the signed electronic fund transfer authorization comprises imaging a signed bank check.

58. The method of claim 54 wherein the annotation comprises marking the bank check as "VOID".

59. A system for electronic processing and settlement of consumer payment for goods or services comprising:

a. a central computer system that includes:
a first communication interface that is communicably connectable to at least one communication network for communicating with at least one terminal; and at least one database; and

b. at least one terminal that includes:
a reader for reading preprinted account information from a bank check;
a keypad for receiving transaction amount entries;
at least one printer capable of printing an authorization agreement, transaction receipts, and annotation of a bank check; and

a communication interface that is connectable to at least one communication network for communication with the central computer system.

60. A system for electronic processing and settlement of consumer payment for goods or services comprising:

a. a central computer system that includes:
a first communication interface that is communicably connectable to at least one communication network for communicating with at least one terminal; and at least one database; and

b. at least one terminal that includes:
an imaging apparatus for imaging a bank check;
a keypad for receiving transaction amount entries;
at least one printer capable of printing an authorization agreement, transaction receipts, and annotation of a bank check; and

a communication interface that is connectable to at least one communication network for communication with the central computer system.

61. A central computer system for enabling the conversion of a bank check into an electronic funds transfer, the electronic funds transfer eliminates presentment of the bank check for payment, the central computer system comprising:

a first communication interface for receiving transaction information and account information from a plurality of point of sale terminals, the account information being read from a bank check;

a memory for storing transaction information and account information;

a second communication interface for communicating with at least one database that includes consumer and merchant information; and

logic to determine whether transactions should be authorized or declined based on information in at least one database.

62. The system of claim 61 wherein the account information is read from preprinted magnetic ink characters.

63. The system of claim 61 wherein the account information comprises a routing number, an account number, and a bank check serial number.

64. The system of claim 61 wherein the at least one database comprises a checkwriter database.

65. The system of claim 61, wherein the merchant information includes information regarding multiple, unrelated merchants that are authorized to use the system.

66. The system of claim 65, wherein the electronic funds transfer is an offline ACH transaction.

67. A method of processing consumer payment from a checking account comprising:

receiving account information via a communication network, the account information relating to a checking account;

storing the account information;

verifying the account information;

receiving transaction event information;

storing the transaction event information; and

transmitting the account information and the transaction event information to a financial institution to initiate an electronic funds transfer.

68. The method of claim 67 wherein the account information comprises a routing number, an account number, and a bank check serial number.

69. The method of claim 68 wherein the electronic funds transfer is an ACH transaction.

70. The method of claim 67 wherein the electronic funds transfer comprises settlement through an electronic settle-

ment network selected from the group comprising national authorization networks, regional authorization networks, and ACH network.

71. The method of claim 67 further comprising means for biometrically identifying a consumer.

72. The method of claim 67 wherein the electronic funds transfer comprises debiting a consumer account and crediting a merchant account.

73. The method of claim 67 wherein verifying the account information comprises cross-searching one or more databases to determine whether a transaction should be approved.

74. The method of claim 67 wherein the communication network comprises the Internet.

75. A method for eliminating the physical presentment of a bank check for payment of goods or services, comprising:

receiving account information from a signed bank check that was received via mail or at a lock box location;

verifying the accuracy of the account information;

receiving a transaction amount as entered on the bank check;

storing the account information and the transaction amount;

transmitting the account information and the transaction amount to a financial institution to initiate an electronic funds transfer.

76. The method of claim 75 further comprising receiving authorization to convert the bank check process to an electronic funds transfer process.

77. The method of claim 75, wherein the account information comprises a routing number, and account number and a bank check serial number.

78. The method of claim 77 wherein the signed bank check is a source document.

79. The method of claim 77, further comprising receiving merchant data from any one of multiple, unrelated merchants.

80. The method of claim 79, wherein the merchant data is compared to data in a merchant database comprising information regarding multiple, unrelated merchants that are authorized to use the method.

81. The method of claim 80, wherein the electronic funds transfer is an offline ACH transaction.

82. The method of claim 75 wherein the electronic funds transfer comprises settlement through an electronic settlement network selected from the group comprising national authorization networks, regional authorization networks, and ACH network.

83. A method for eliminating the physical presentment of a bank check for payment of goods or services, comprising:

receiving a signed bank check including authorization to convert the bank check process to an electronic funds transfer process via mail or at a lock box location;

reading, with an optical or magnetic reader, preprinted account information from the signed bank check;

verifying the accuracy of the account information;

receiving a transaction amount as entered on the bank check;

transmitting the account information and the transaction amount to a central computer;

storing the account information and the transaction amount;

transmitting the account information and the transaction amount to a financial institution to initiate an electronic funds transfer.

84. The method of claim 83 wherein the signed bank check is a source document.

85. The method of claim 44, further comprising receiving merchant data from any one of multiple, unrelated merchants.

86. The method of claim 85, wherein the merchant data is compared to data in a merchant database comprising information regarding multiple, unrelated merchants that are authorized to use the method.

87. The method of claim 86, wherein the electronic funds transfer is an offline ACH transaction initiated by the central computer without human intervention.

88. A method of eliminating the presentment of a consumer bank check for payment of goods or services, the method comprising:

receiving account information from a consumer bank check;

receiving a transaction amount;

transmitting the account information and the transaction amount;

annotating the bank check; and

originating an electronic funds transfer after the bank check has been annotated, wherein originating the electronic funds transfer is the last step of the method.

89. The method of claim 88 wherein in the electronic funds transfer is an ACH debit for the purchase of goods or services.

90. The method of claim 88 wherein receiving the account information is done by reading magnetic ink characters from the bank check.

91. The method of claim 88 wherein annotating the bank check comprises marking it as "void".

92. The method of claim 88 further comprising storing the account information and the transaction information.

93. A system for electronic processing and settlement of consumer payment for goods or services comprising:

at least one terminal adapted to receive consumer bank account information from a consumer communicating with the terminal over the Internet;

a central computer system;

at least one central computer system communication interface for electronic communication between at least one terminal and the central computer system; and

at least one database for performing a consumer bank account status search, and further enabling electronic funds transfer communication for transferring funds without presentment of a bank check to an issuing financial institution.

94. The system of claim 93 wherein the terminal is further adapted to print activity reports of transaction events occurring at the terminal.

95. The system of claim 93 further comprising means for biometrically verifying identity of a consumer.

96. The system of claim 93 further comprising at least one consumer identification element selected from the group comprising voice pattern recognition, fingerprint identification, retina scan, geometrics, biometrics, smart chips, consumer imaging broadcasting, check imaging broadcasting and signature broadcasting.

97. The system of claim 93 comprising at least one biometric reader.

98. The system of claim 93 further comprising at least one fraud identification element selected from the group comprising, fingerprint capture and analysis, signature capture and verification, imaging technology, retina scan, and biometrics.

99. A method for electronic processing and settlement of consumer payment for goods or services comprising:

receiving from a bank check, at a point of sale, checking account information, including bank identification information;

storing the checking account information obtained;

providing transaction event information;

annotating the bank check; and

transmitting the transaction event information for subsequent electronic funds transfer operations;

wherein a checking account identified by the checking account information is debited for a transaction identified by the transaction event information without presenting the check to a bank.

100. A method for electronic processing of consumer payment for goods or services comprising:

receiving account information from a bank check;

receiving a transaction amount;

receiving authorization for an electronic funds transfer, the authorization being for the transaction amount;

submitting the account information and the transaction amount for electronic settlement; and

annotating the bank check.

101. The method of claim 20, wherein the at least one database comprises a checkwriter database.

102. The method of claim 101, further comprising receiving merchant data from any one of multiple, unrelated merchants.

103. The method of claim 102, wherein the electronic funds transfer is an offline ACH debit, the offline ACH debit replacing a transaction that uses a written check retained by a merchant for subsequent negotiation.

104. A method for electronic processing and settlement of consumer payment for goods or services comprising:

reading preprinted account information from a bank check drawn on an account, the preprinted account information comprising a routing number, an account number, and a bank check serial number;

receiving a transaction amount;

transmitting the account information and the transaction amount;

receiving written authorization for an ACH debit in the transaction amount;

receiving an approval for the ACH debit based on the status of an account on which the bank check is drawn;

annotating the bank check by printing "void";

returning the annotated bank check to a consumer;

printing a receipt for the ACH debit; and

executing a set of computer instructions to originate, without human intervention, the ACH debit for the purchase of goods or services, the ACH debit replacing a transaction that relies on presentment of a written bank check.

* * * * *

UNITED STATES PATENT AND TRADEMARK OFFICE
CERTIFICATE OF CORRECTION

PATENT NO. : RE 40,220 E
APPLICATION NO. : 10/889639
DATED : April 8, 2008
INVENTOR(S) : Henry R. Nichols and Robert R. Hills

Page 1 of 1

It is certified that error appears in the above-identified patent and that said Letters Patent is hereby corrected as shown below:

Column 21, line 24, amend claim 25 to add language as shown:

“25. The method of claim 24, wherein the electronic funds transfer is an offline ACH debit, the offline ACH debit replacing a transaction that uses a written --check retained by a merchant for subsequent negotiation.--”

Column 21, line 63, the first sentence of claim 36 should read “36. A method for electronic processing and settlement for consumer payment for goods or services --comprising--:”

Column 23, line 21, the word “abank” should be changed to the words --a bank--.

Column 26, line 3, the number “44” should be changed to the number --83--.

Signed and Sealed this

Eighth Day of July, 2008



JON W. DUDAS

Director of the United States Patent and Trademark Office

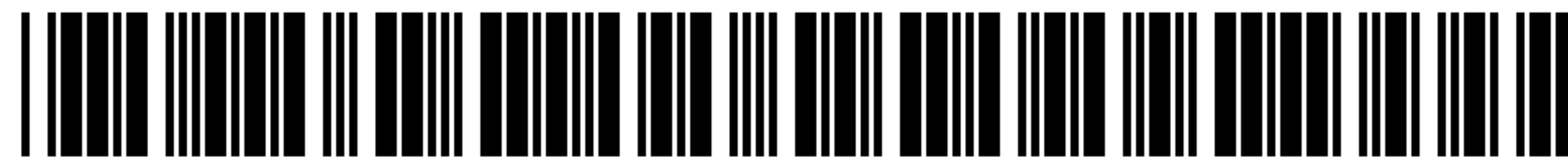

US00RE40220C1

(12) **EX PARTE REEXAMINATION CERTIFICATE** (8996th)
United States Patent
Nichols et al.

(10) **Number:** **US RE40,220 C1**
(45) **Certificate Issued:** ***May 8, 2012**

(54) **CHECK WRITING POINT-OF-SALE SYSTEM**

(76) Inventors: **Henry R. Nichols**, McLean, VA (US);
Robert R. Hills, Sugarloaf Key, FL (US)

Reexamination Request:

No. 90/011,749, Jun. 17, 2011

Reexamination Certificate for:

Patent No.: **Re. 40,220**
Issued: **Apr. 8, 2008**
Appl. No.: **10/889,639**
Filed: **Jul. 12, 2004**

(*) Notice: This patent is subject to a terminal disclaimer.

Certificate of Correction issued Jul. 8, 2008.

Related U.S. Patent Documents

Reissue of:

(64) Patent No.: **6,547,129**
Issued: **Apr. 15, 2003**
Appl. No.: **10/096,019**
Filed: **Mar. 11, 2002**

Related U.S. Application Data

(63) Continuation of application No. 09/851,609, filed on May 9, 2001, now Pat. No. 6,354,491, which is a division of application No. 09/562,303, filed on May 1, 2000, now Pat. No. 6,283,366, which is a continuation of application No. 08/775,400, filed on Dec. 31, 1996, now Pat. No. 6,164,528.

(51) **Int. Cl.**
G07F 19/00 (2006.01)

(52) **U.S. Cl.** **235/379; 235/380**

(58) **Field of Classification Search** None
See application file for complete search history.

(56) **References Cited**

To view the complete listing of prior art documents cited during the proceeding for Reexamination Control Number 90/011,749, please refer to the USPTO's public Patent Application Information Retrieval (PAIR) system under the Display References tab.

Primary Examiner—Lynne H Browne

(57) **ABSTRACT**

A point of sale system designed to read information from a consumer's check, credit card, or manual input with a subsequent debiting of a consumer's account and crediting merchant's account for the goods or services provided. Point of sale terminals are designed to accept a form of credit card with a consumer's bank account information encoded thereon or in the alternative to read the MICR number from a consumer's check in order to verify that a consumer has an appropriate balance to conduct the transaction with a given merchant. Thereafter the transaction of that information is transmitted to a central computer system which verifies the consumer's credit worthiness and stores the transaction event information for subsequent bank reconciliation via the ACH or other competing network. The invention eliminates the need for paper checks with all bank reconciliation being accomplished electronically. The present invention also includes fraud protection provisions such as velocity controls, social security checks, and scans. The present invention has the further flexibility to differentiate between "first time" consumer usage and those limits otherwise assigned to "known" consumer accounts. Additionally, there is not need for the present system to retain the consumer's check after verification.

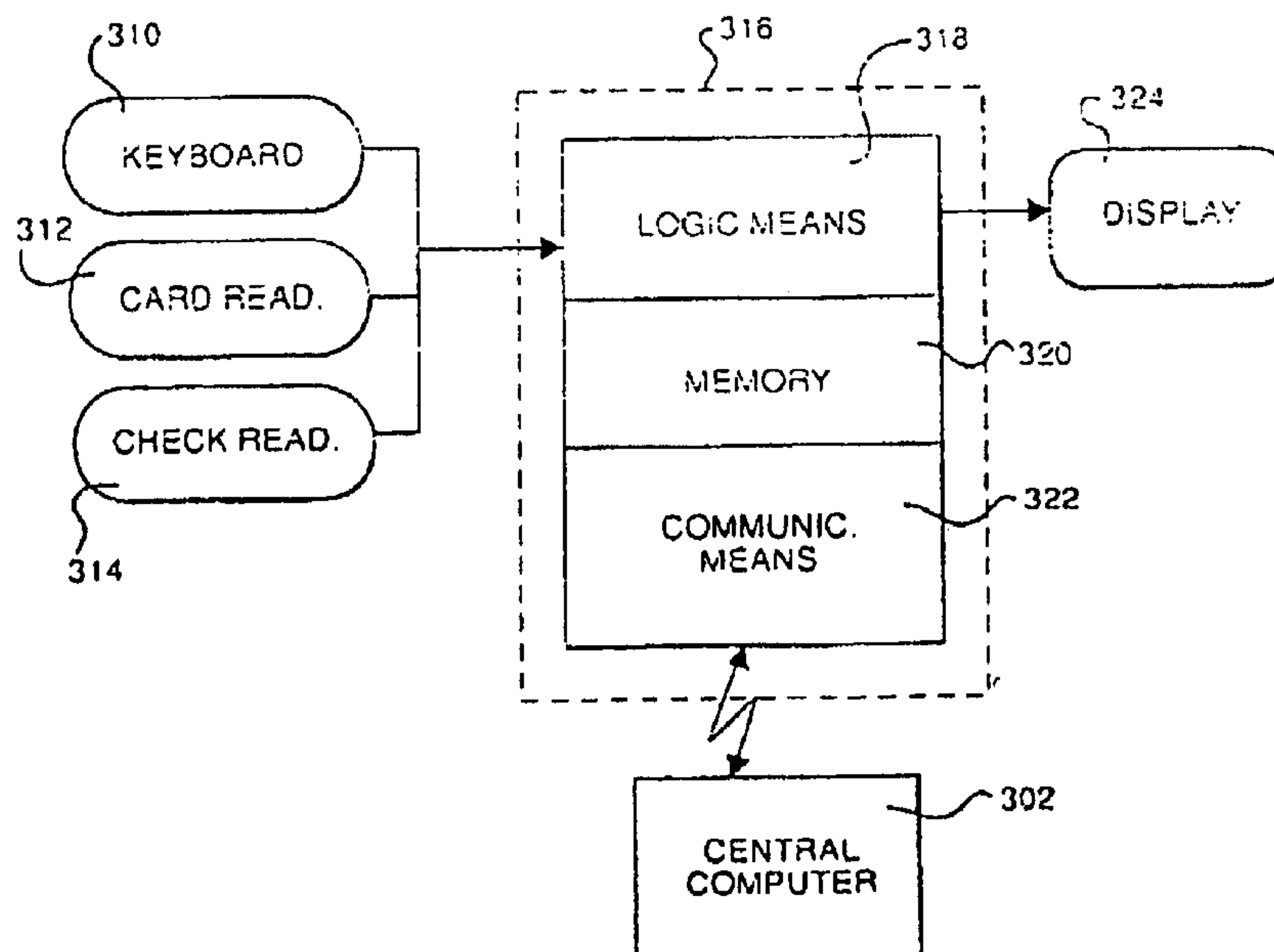

1
EX PARTE
REEXAMINATION CERTIFICATE
ISSUED UNDER 35 U.S.C. 307

THE PATENT IS HEREBY AMENDED AS
INDICATED BELOW.

Matter enclosed in heavy brackets [] appeared in the original patent but was deleted by the reissue patent; matter printed in italics was added by the reissue patent. Matter enclosed in heavy double brackets [[] appeared in the reissue patent but is deleted by this reexamination certificate; matter printed in boldface is added by this reexamination certificate.

AS A RESULT OF REEXAMINATION, IT HAS BEEN DETERMINED THAT:

The patentability of claims 67-74 is confirmed.

Claims 1-4 were previously cancelled.

Claims 5-9 and 11-26 are cancelled.

Claim 10 is determined to be patentable as amended.

New claims 105-140 are added and determined to be patentable.

Claims 27-66 and 75-104 were not reexamined.

10. **[[The method of claim 9,]]** A method for electronic processing of consumer payment for goods or services without use of a bank check as a negotiable instrument, comprising:

receiving account information from a bank check presented by a consumer, the account information including at least a checking account number and a bank routing number;

receiving a transaction amount;

receiving written authorization for an electronic funds transfer, from the consumer, the authorization being for the transaction amount, wherein the written authorization is to convert a bank check settlement process to an electronic funds transfer process, and *wherein receiving written authorization comprises receiving a bank check bearing a [[consumer's]] signature of the consumer and printing an electronic funds transfer notice on the bank check;*

transmitting authorization information for authorizing a transmission of account information over a communication network, the authorization information including at least an authorization code;

transmitting the account information and the transaction amount;

storing the account information;

storing the transaction amount;

verifying the account information, wherein verifying the account information includes confirming that the account information is accurate by determining whether the account information includes inaccurate, incomplete or fraudulent data, and wherein verifying the account information includes performing at least MOD 10 verification;

2

annotating the bank check; and
submitting the account information and the transaction amount to a financial institution for electronic settlement,

5 wherein the electronic settlement includes the electronic funds transfer, wherein initiating the electronic funds transfer includes sending the account information and the transaction amount to the financial institution to begin the electronic funds transfer using a formatted ACH file in an off-batch transmission,

10 wherein the electronic funds transfer comprises settlement through an electronic settlement network selected from the group comprising national authorization networks, regional authorization networks, and ACH network,

15 wherein the electronic funds transfer is the transfer of funds electronically without use of the bank check as a negotiable instrument, and

20 wherein the transmitting step is performed after the receiving steps.

105. A method of processing consumer payment from a checking account through the transfer of funds electronically without the use of a bank check as a negotiable instrument, comprising:

25 receiving information relating to an account, including at least an account number, via a communication network, the received information relating to a checking account;

30 storing the information relating to an account, including at least the account number;

confirming that the information relating to an account is accurate;

receiving transaction event information;

35 storing transaction event information; and

40 sending the received information relating to an account and the transaction event information to a state or national bank, a state or federal savings and loan association, mutual savings bank, or credit union, or to any other person who, directly or indirectly, holds an account belonging to a consumer or who issues an access device and agrees with a consumer to provide electronic fund transfer services, to begin a transfer of funds electronically without use of a bank check as a negotiable instrument, the sending step only being performed after the receiving steps have been performed.

106. The method of claim 105, wherein the transfer of funds electronically without use of a bank check as a negotiable instrument comprises settlement through an electronic settlement network selected from the group consisting of national authorization networks, regional authorization networks, and ACH network.

107. The method of claim 105, wherein the communication network comprises the Internet.

108. The method of claim 105, further comprising receiving a written authorization to initiate the transfer of funds electronically without use of a bank check as a negotiable instrument.

65 109. The method of claim 105, further comprising receiving an authorization to initiate the transfer of funds electronically without use of a bank check as a negotiable instrument, wherein the authorization comprises receiving a bank check bearing a signature of the consumer.

110. The method of claim 105, wherein receiving information relating to a checking account further comprises

receiving information obtained from the bank check bearing a signature of the consumer and authorization from the consumer to convert a bank check settlement process to an electronic funds transfer process.

111. A method for eliminating the physical present-
5 ment of a bank check for payment of goods or services through a transfer of funds electronically without use of a bank check as a negotiable instrument, comprising:

receiving information relating to an account, including
at least an account number, that has been obtained
10 from a signed bank check that was received via mail or at a lock box location;

determining whether the received information relating
to the account read from the signed bank check
15 matches the account information on the signed bank check;

receiving a transaction amount as entered on the
signed bank check;

storing the information relating to the account and the
20 transaction amount; and

25 sending the information relating to the account and the transaction amount to a state or national bank, a state or federal savings and loan association, mutual savings bank, or credit union, or to any other person who, directly or indirectly, holds an account belonging to a consumer or who issues an access device and agrees with a consumer to provide electronic fund transfer services, to begin a transfer of funds electronically without the use of the bank check as a
30 negotiable instrument, the sending step only being performed after the receiving steps have been performed.

112. The method of claim 111, wherein the transfer of
35 funds electronically without use of the bank check as a negotiable instrument comprises settlement through an electronic settlement network selected from the group consisting of national authorization networks, regional authorization networks, and ACH network.

113. The method of claim 111, wherein receiving infor-
40 mation relating to an account of a consumer includes using a communication network comprising the Internet.

114. The method of claim 111, further comprising
45 receiving a written authorization to begin the transfer of funds electronically without use of the bank check as a negotiable instrument.

115. The method of claim 111, further comprising
50 receiving an authorization to begin the transfer of funds electronically without use of the bank check as a negotiable instrument, wherein the authorization comprises receiving the signed bank check bearing a signature of the consumer.

116. The method of claim 111, wherein receiving the
55 information related to the account further comprises receiving information obtained from the bank check bearing a signature of the consumer and authorization from the consumer to convert a bank check settlement process to an electronic funds transfer process.

117. The method of claim 111, further comprising veri-
60 fying the information related to the account,

wherein verifying the account information includes
confirming that the information related to the
account is accurate and cancelling processing con-
sumer payment when verifying the information
65 related to the account determines that the information related to the account includes inaccurate, incomplete or fraudulent data, and

wherein verifying the information related to the
account includes performing at least MOD 10 verifi-
cation on a bank routing number.

118. A method of processing consumer payment from
5 a checking account without use of a bank check as a negotiable instrument, comprising:

receiving authorization information for authorizing a
transmission of account information over a commu-
nication network, the authorization information
including at least an authorization code;

receiving the account information via the communi-
cation network, wherein the account information is
information relating to a checking account of a con-
sumer and including at least an account number
and a bank routing number obtained from a bank
15 check issued for the checking account, wherein the bank check is paper;

storing the account information including the account
number and the bank routing number;

20 verifying the account information,
wherein verifying the account information includes
confirming that the account information is accu-
rate by determining whether the account infor-
mation includes inaccurate, incomplete or
fraudulent data,

25 wherein verifying the account information further
includes performing at least MOD 10 verification
on the bank routing number; and

receiving transaction event information, wherein the
transaction event information is information relat-
ing to a sale;

30 storing the transaction event information; and

transmitting the account information and the transac-
tion event information to a financial institution to
initiate an electronic funds transfer,

35 wherein initiating the electronic funds transfer
includes sending the checking account informa-
tion and the transaction event information to the
financial institution to begin the electronic funds
transfer using a formatted ACH file in an off-line
batch transmission,

40 wherein the electronic funds transfer is the transfer
of funds electronically without use of the bank
check as a negotiable instrument, and

45 wherein the transmitting step is performed after the
receiving steps.

119. The method of claim 118, wherein the electronic
funds transfer comprises settlement through an elec-
tronic settlement network selected from the group com-
prising national authorization networks, regional autho-
rization networks, and ACH network.

120. The method of claim 118, wherein the communi-
50 cation network comprises the Internet.

121. The method of claim 118, further comprising
receiving a written authorization to initiate the electronic
funds transfer.

122. The method of claim 118, further comprising
55 receiving an authorization to initiate the electronic funds
transfer, wherein receiving an authorization comprises
receiving a bank check bearing a signature of the con-
sumer.

123. The method of claim 118, wherein receiving the
60 account information further comprises receiving infor-
mation obtained from the bank check bearing a signa-
ture of the consumer and authorization from the con-
sumer to convert a bank check settlement process to an
electronic funds transfer process.

124. A method for eliminating the physical present-
ment of a bank check for payment of goods or services

5

through a transfer of funds electronically without use of a bank check as a negotiable instrument, comprising:

receiving authorization information for authorizing a transmission of account information over a communication network, the authorization information including at least an authorization code;

receiving the account information that has been obtained from a signed bank check that was received via mail or at a lock box location,

wherein the account information is information relating to a bank account of a consumer, including at least an account number and a bank routing number,

wherein the signed bank check is a paper bank check issued from the bank account of the consumer;

verifying the accuracy of the account information, wherein verifying the accuracy of the account information includes determining whether the account information read from the signed bank check matches the account information on the signed bank check;

receiving a transaction amount as entered on the signed bank check;

storing the account information and the transaction amount;

transmitting the account information and the transaction amount to a financial institution to initiate an electronic funds transfer,

wherein initiating the electronic funds transfer includes sending the account information and the transaction amount to the financial institution to begin the electronic funds transfer using a formatted ACH file in an off-line batch transmission, wherein the electronic funds transfer is the transfer of funds electronically without use of the bank check as a negotiable instrument, and

wherein the transmitting step is performed after the receiving steps.

125. The method of claim 124, wherein the electronic funds transfer comprises settlement through an electronic settlement network selected from the group comprising national authorization networks, regional authorization networks, and ACH network.

126. The method of claim 124, wherein receiving account information includes using a communication network comprising the Internet.

127. The method of claim 124, further comprising receiving a written authorization to initiate the electronic funds transfer.

128. The method of claim 124, further comprising receiving an authorization to initiate the electronic funds transfer, wherein the authorization comprises receiving the signed bank check bearing a signature of the consumer.

129. The method of claim 124, wherein receiving the account information further comprises receiving information obtained from the bank check bearing a signature of the consumer and authorization from the consumer to convert a bank check settlement process to an electronic funds transfer process.

130. The method of claim 124, further comprising verifying the account information, wherein verifying the account information includes confirming that the account information is accurate and cancelling processing consumer payment when verifying the account information determines that the account information includes inaccurate, incomplete or fraudulent data, and

6

wherein verifying the account information includes performing at least MOD 10 verification on the bank routing number.

131. A method of processing consumer payment from a checking account without use of a bank check as a negotiable instrument, comprising:

receiving authorization information for authorizing a transmission of account information over a communication network, the authorization information including at least an authorization code, wherein the communication network comprises the Internet;

receiving the account information via the communication network,

wherein the account information is information relating to a checking account of a consumer and including at least an account number and a bank routing number obtained from a bank check issued for the checking account,

wherein the bank check is paper, and

wherein receiving the account information further comprises receiving information obtained from the paper bank check bearing a signature of the consumer and a written authorization from a consumer to convert a bank check settlement process to an electronic funds transfer process;

storing the account information including the account number and the bank routing number;

verifying the account information,

wherein verifying the account information includes confirming that the account information is accurate by determining whether the account information includes inaccurate, incomplete or fraudulent data, and

wherein verifying the account information includes performing at least MOD 10 verification on the bank routing number;

receiving transaction event information, wherein the transaction event information is information relating to a sale;

storing the transaction event information; and

transmitting the account information and the transaction event information to a financial institution to initiate the electronic funds transfer,

wherein initiating the electronic funds transfer includes sending the account information and the transaction event information to the financial institution to begin the electronic funds transfer using a formatted ACH file in an off-line batch transmission,

wherein the electronic funds transfer comprises settlement through an electronic settlement network selected from the group comprising national authorization networks, regional authorization networks, and ACH network,

wherein the electronic funds transfer is the transfer of funds without use of the bank check as the negotiable instrument, and

wherein the transmitting step is performed after the receiving steps.

132. A method for eliminating the physical presentation of a bank check for payment of goods or services through a transfer of funds electronically without use of a bank check as a negotiable instrument, comprising:

receiving authorization information for authorizing a transmission of account information over a communication network, the authorization information including at least an authorization code, wherein the communication network comprises the Internet;

7

receiving the account information that has been obtained from a signed bank check that was received via mail or at a lock box location, wherein the account information is information relating to a bank account of the consumer, including at least an account number and a bank routing number, wherein the signed bank check is a paper bank check issued from the bank account of the consumer, wherein the receiving the account information further comprises receiving information obtained from the signed bank check bearing the consumer's signature and a written authorization from the consumer to convert a bank check settlement process to an electronic funds transfer process, and wherein the receiving uses the communication network;

verifying the accuracy of the account information, wherein verifying the accuracy of the account information includes determining whether the account information read from the signed bank check matches the account information on the signed bank check;

verifying the account information, wherein verifying the account information includes confirming that the account information is accurate by determining whether the account information includes inaccurate, incomplete or fraudulent data, and wherein verifying the account information includes performing at least MOD 10 verification on the bank routing number;

receiving a transaction amount as entered on the signed bank check;

storing the account information and the transaction amount;

transmitting the account information and the transaction amount to a financial institution to initiate the electronic funds transfer, and wherein initiating the electronic funds transfer includes sending the account information and the transaction amount to the financial institution to begin the electronic funds transfer using a formatted ACH file in an off-line batch transmission, wherein the electronic funds transfer comprises settlement through an electronic settlement network selected from the group comprising national authorization networks, regional authorization networks, and ACH network, wherein the electronic funds transfer is the transfer of funds electronically without use of the signed bank check as a negotiable instrument, and wherein the transmitting step is performed after the receiving steps.

133. A method of processing consumer payment from a checking account without use of a bank check as a negotiable instrument comprising:

receiving authorization information for authorizing a transmission of account information over a communication network, the authorization information including at least an authorization code, wherein the communication network is the Internet;

receiving the account information from a bank check via the communication network, the account infor-

8

mation relating to a checking account and including an account number and a bank routing number, wherein the bank check is paper;

storing the account information, including the account number and the bank routing number;

verifying the account information, wherein verifying the account information includes confirming that the account information is accurate and canceling processing consumer payment when verifying the account information determines that the account information includes inaccurate, incomplete or fraudulent data, and wherein verifying the account information includes performing at least MOD 10 verification;

receiving transaction event information, the transaction event information relating to a sale;

storing the transaction event information; and

transmitting the account information and the transaction event information to a financial institution to initiate an electronic funds transfer wherein initiating the electronic funds transfer includes sending the account information and the transaction event information to the financial institution to begin the electronic funds transfer using a formatted ACH file in an off-line batch transmission, wherein the electronic funds transfer comprises settlement through an electronic settlement network selected from a group consisting of national authorization networks, regional authorization networks, and ACH network, and wherein the electronic funds transfer is the transfer of funds without use of the bank check as the negotiable instrument.

134. The method of claim 133, further comprising receiving a written authorization to initiate the electronic funds transfer.

135. The method of claim 133, further comprising receiving an authorization to initiate the electronic funds transfer, wherein receiving an authorization comprises receiving a bank check bearing a signature of the consumer.

136. The method of claim 133, wherein receiving the account information further comprises receiving information obtained from the bank check bearing a signature of the consumer and authorization from the consumer to convert a bank check settlement process to an electronic funds transfer process.

137. A method for eliminating the physical presentation of a bank check for payment of goods or services through a transfer of funds electronically without use of a bank check as a negotiable instrument, comprising:

receiving authorization information for authorizing a transmission of account information over a communication network, the authorization information including at least an authorization code; wherein the communication network is the Internet;

receiving the account information, via the communication network, that has been obtained from a signed bank check that was received via mail or at a lock box location, the account information relating to a checking account and including an account number and a bank routing number, wherein the signed bank check is a paper check issued from the bank account of the consumer, and

verifying the accuracy of the account information;

verifying the account information,
 wherein verifying the account information includes
 confirming that the account information is accu-
 rate and cancelling processing consumer payment
 when verifying the account information deter-
 mines that the account information includes
 inaccurate, incomplete or fraudulent data, and
 wherein verifying the account information includes
 performing at least MOD 10 verification;
 receiving a transaction amount as entered on the bank
 check;
 storing the account information and the transaction
 amount;
 transmitting the account information and the transac-
 tion amount to a financial institution to initiate an
 electronic funds transfer,
 wherein initiating the electronic funds transfer
 includes sending the checking account informa-
 tion and the transaction amount to the financial
 institution to begin the electronic funds transfer
 using a formatted ACH file in an off-line batch
 transmission,
 wherein the electronic funds transfer comprises
 settlement through an electronic settlement net-

work selected from a group comprising national
 authorization networks, regional authorization
 networks, and ACH network, and
 wherein the electronic funds transfer is the transfer
 of funds without use of the bank check as a nego-
 tiable instrument.

138. The method of claim 137, further comprising
 receiving a written authorization to initiate the electronic
 funds transfer.

139. The method of claim 137, further comprising
 receiving an authorization to initiate the electronic funds
 transfer, wherein the authorization comprises receiving
 the signed bank check bearing a signature of the con-
 sumer.

140. The method of claim 137, wherein receiving the
 account information further comprises receiving infor-
 mation obtained from the bank check bearing a signa-
 ture of the consumer and authorization from the con-
 sumer to convert a bank check settlement process to an
 electronic funds transfer process.

* * * * *



US00RE40220C1

(12) **INTER PARTES REEXAMINATION CERTIFICATE (733rd)**

United States Patent

Nichols et al.

(10) **Number:** **US RE40,220 C1**

(45) **Certificate Issued:** ***Nov. 12, 2013**

(54) **CHECK WRITING POINT OF SALE SYSTEM**

(75) Inventors: **Henry R. Nichols**, McLean, VA (US);
Robert R. Hills, Sugarloaf Key, FL (US)

(73) Assignee: **LML Patent Corp.**, Vancouver, BC
(CA)

(52) **U.S. Cl.**
USPC **235/379; 235/380**

(58) **Field of Classification Search**
None
See application file for complete search history.

(56) **References Cited**

To view the complete listing of prior art documents cited during the proceeding for Reexamination Control Number 95/000,545, please refer to the USPTO's public Patent Application Information Retrieval (PAIR) system under the Display References tab.

Primary Examiner — My Trang Nu Ton

Reexamination Request:

No. 95/000,545, May 11, 2010

Reexamination Certificate for:

Patent No.: **Re. 40,220**
Issued: **Apr. 8, 2008**
Appl. No.: **10/889,639**
Filed: **Jul. 12, 2004**

Certificate of Correction issued Jul. 8, 2008

(*) Notice: This patent is subject to a terminal disclaimer.

Related U.S. Patent Documents

Reissue of:

(64) Patent No.: **6,547,129**
Issued: **Apr. 15, 2003**
Appl. No.: **10/096,019**
Filed: **Mar. 11, 2002**

Related U.S. Application Data

(60) Continuation of application No. 09/851,609, filed on May 9, 2001, now Pat. No. 6,354,491, which is a division of application No. 09/562,303, filed on May 1, 2000, now Pat. No. 6,283,366, which is a continuation of application No. 08/775,400, filed on Dec. 31, 1996, now Pat. No. 6,164,528.

(51) **Int. Cl.**
G07F 19/00 (2006.01)

(57) **ABSTRACT**

A point of sale system designed to read information from a consumer's check, credit card, or manual input with a subsequent debiting of a consumer's account and crediting merchant's account for the goods or services provided. Point of sale terminals are designed to accept a form of credit card with a consumer's bank account information encoded thereon or in the alternative to read the MICR number from a consumer's check in order to verify that a consumer has an appropriate balance to conduct the transaction with a given merchant. Thereafter the transaction of that information is transmitted to a central computer system which verifies the consumer's credit worthiness and stores the transaction event information for subsequent bank reconciliation via the ACH or other competing network. The invention eliminates the need for paper checks with all bank reconciliation being accomplished electronically. The present invention also includes fraud protection provisions such as velocity controls, social security checks, and scans. The present invention has the further flexibility to differentiate between "first time" consumer usage and those limits otherwise assigned to "known" consumer accounts. Additionally, there is not need for the present system to retain the consumer's check after verification.

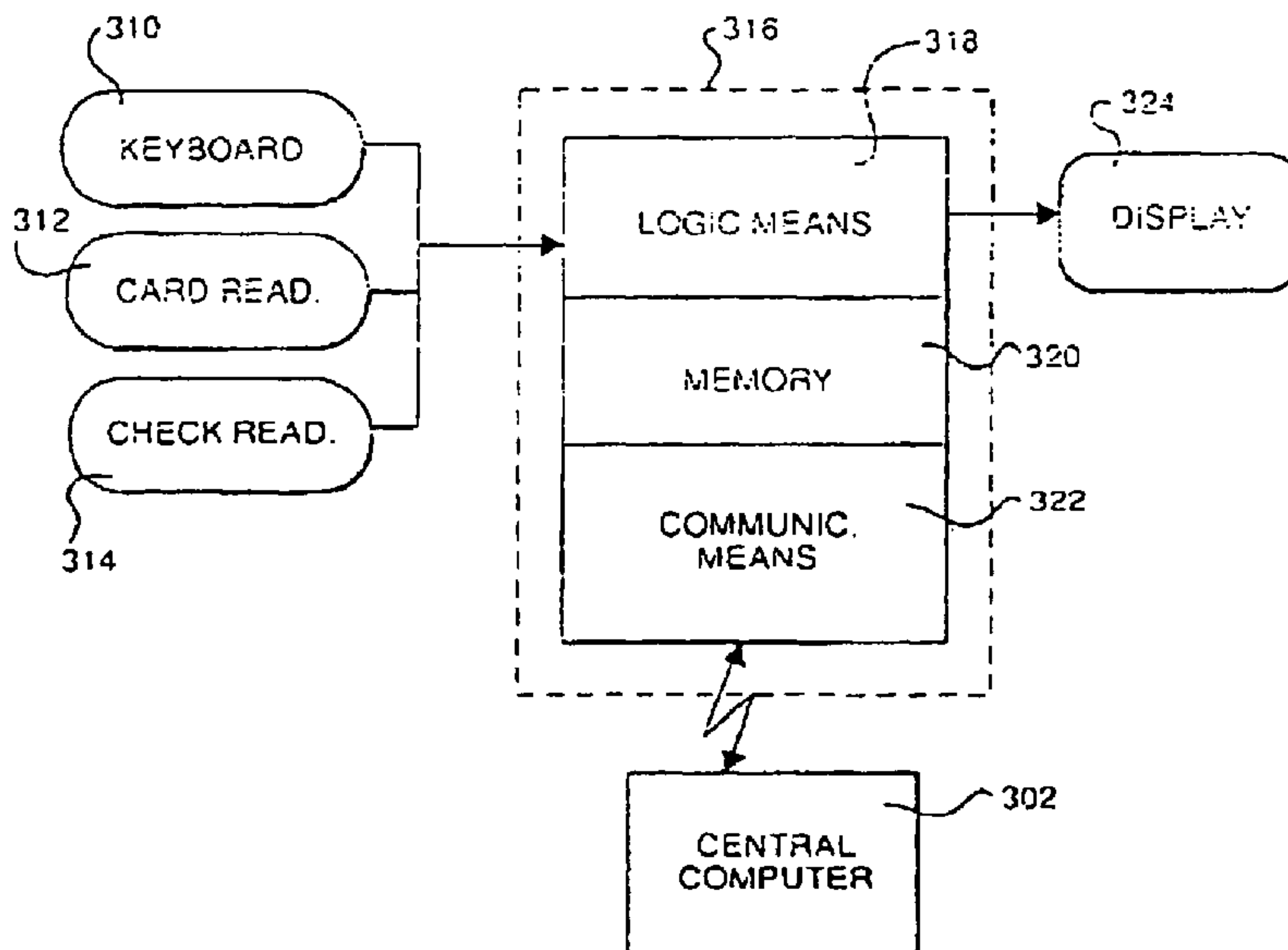

**INTER PARTES
REEXAMINATION CERTIFICATE
ISSUED UNDER 35 U.S.C. 316**

THE PATENT IS HEREBY AMENDED AS
INDICATED BELOW.

5

AS A RESULT OF REEXAMINATION, IT HAS BEEN
DETERMINED THAT:

10

Claims 1-4 were previously cancelled.

Claims 67-70, 72, 74-80, 82-84 and 93 are cancelled.

Claims 5-66, 71, 73, 81, 85-92 and 94-103 were not
reexamined.

15

* * * * *