



US00RE40219E

(19) **United States**
(12) **Reissued Patent**
Bonningue

(10) **Patent Number: US RE40,219 E**
(45) **Date of Reissued Patent: Apr. 8, 2008**

(54) **DIAPHRAGM PUMP COMPRISING ON AT LEAST A PORTION OF ITS PERIPHERY PREFERRED DEFORMATION ZONE AND A RECEPTACLE FITTED THEREWITH**

5,704,519 A 1/1998 Crosnier et al.
6,202,896 B1 3/2001 Bonningue

FOREIGN PATENT DOCUMENTS

(75) Inventor: **Philippe Bonningue**, Paris (FR)

FR 2 728 809 * 7/1996

(73) Assignee: **L'Oreal**, Paris (FR)

FR 2728809 7/1996

* cited by examiner

(21) Appl. No.: **10/383,545**

(22) Filed: **Mar. 10, 2003**

Primary Examiner—Philippe Derakshani

(74) Attorney, Agent, or Firm—Olliff & Berridge, PLC

Related U.S. Patent Documents

Reissue of:

(64) Patent No.: **6,299,029**
Issued: **Oct. 9, 2001**
Appl. No.: **09/564,667**
Filed: **May 4, 2000**

(57) **ABSTRACT**

The invention provides a pump of type comprising a moving member mounted to move relative to a support, the moving member having a central duct into which the substance to be dispensed penetrates via at least one opening, the support co-operating with the moving member to define a variable volume pump chamber around said central duct, the pump also having a diaphragm having a central portion in the form of a sleeve that is open at its top end and closed at its bottom end, said central duct being inserted in said central portion, the diaphragm being organized in such a manner as to isolate the opening(s) of the pump chamber when the volume of the pump chamber increases and the substance is sucked into it. The bottom portion of the central portion of the diaphragm presents, at least over a sector of its periphery, a preferred deformation zone.

(30) **Foreign Application Priority Data**

May 6, 1999 (FR) 99 05772

(51) **Int. Cl.**
B65D 37/00 (2006.01)

(52) **U.S. Cl.** 222/207; 222/321.7

(58) **Field of Classification Search** 222/207,
222/321.7, 321.2

See application file for complete search history.

(56) **References Cited**

U.S. PATENT DOCUMENTS

4,890,773 A 1/1990 Corsette

45 Claims, 6 Drawing Sheets

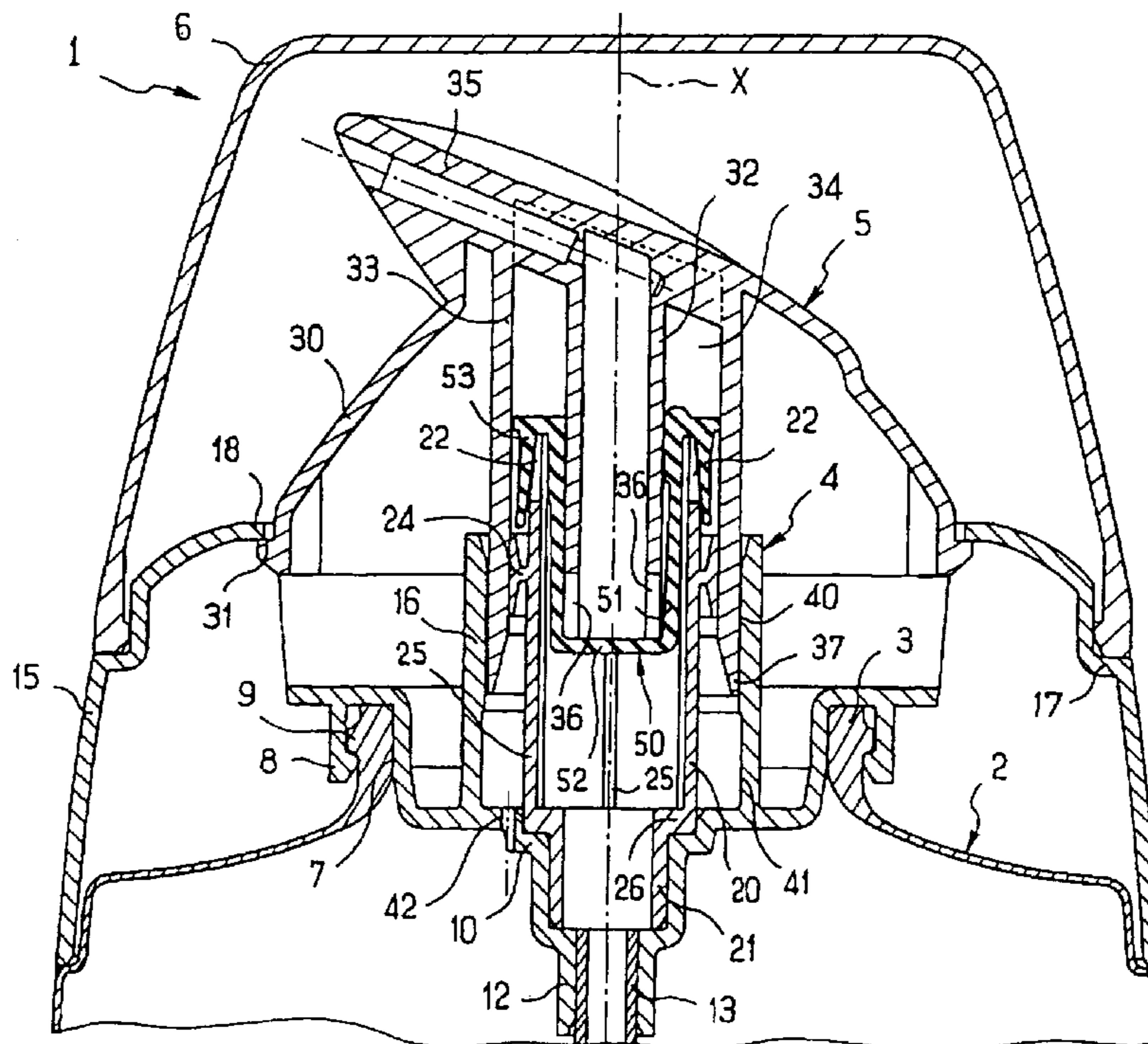
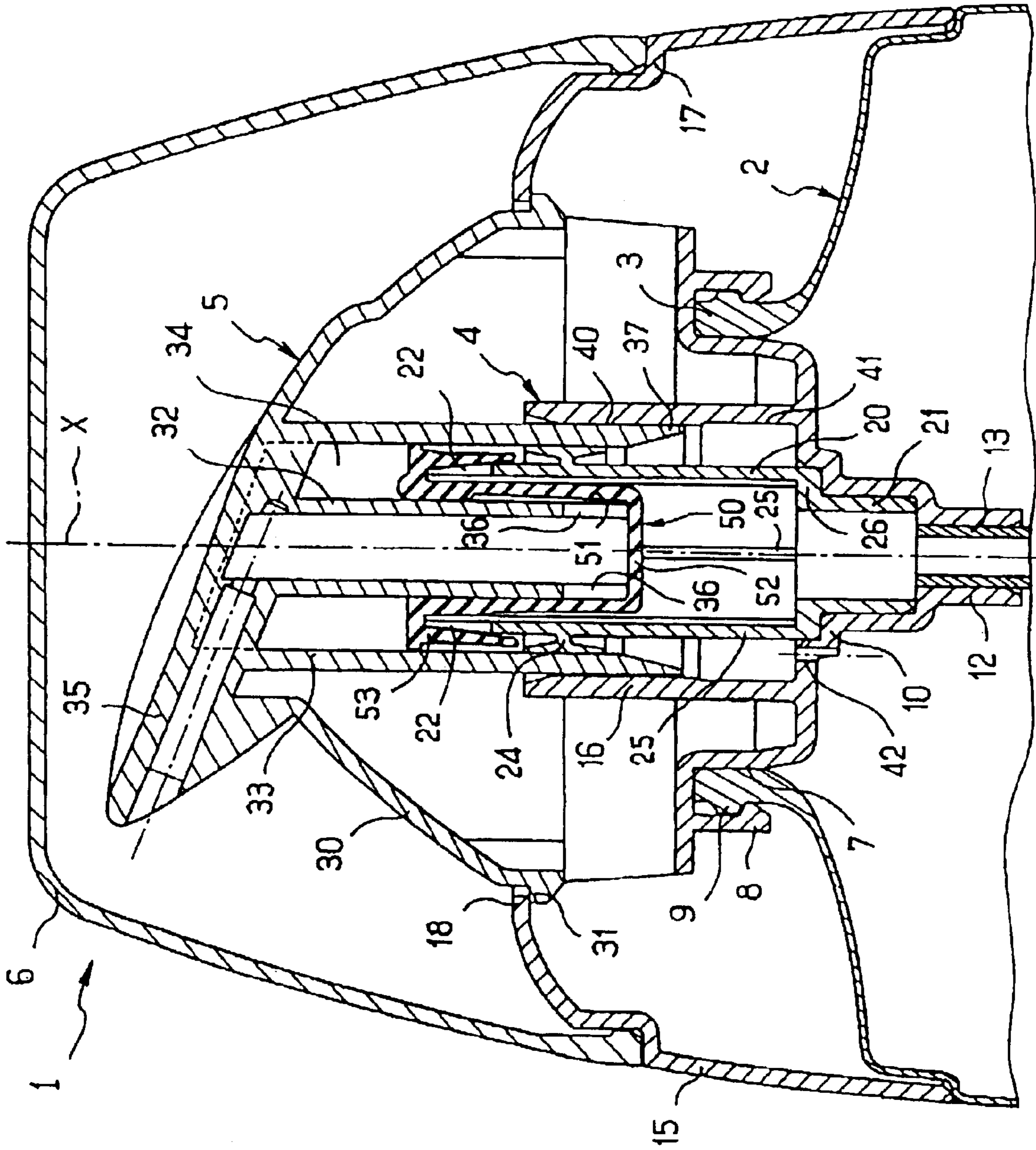

FIG. 1



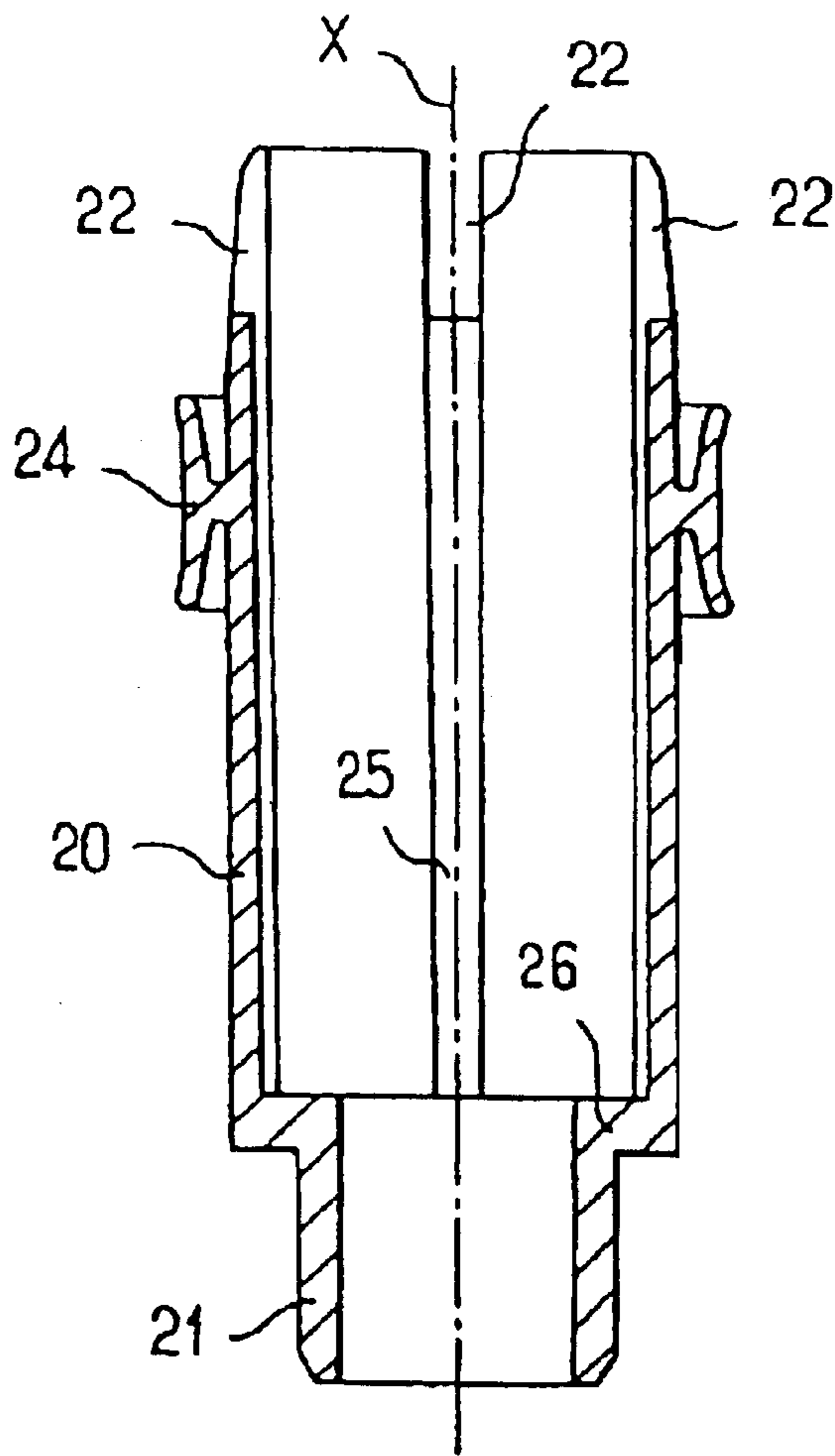

FIG. 2

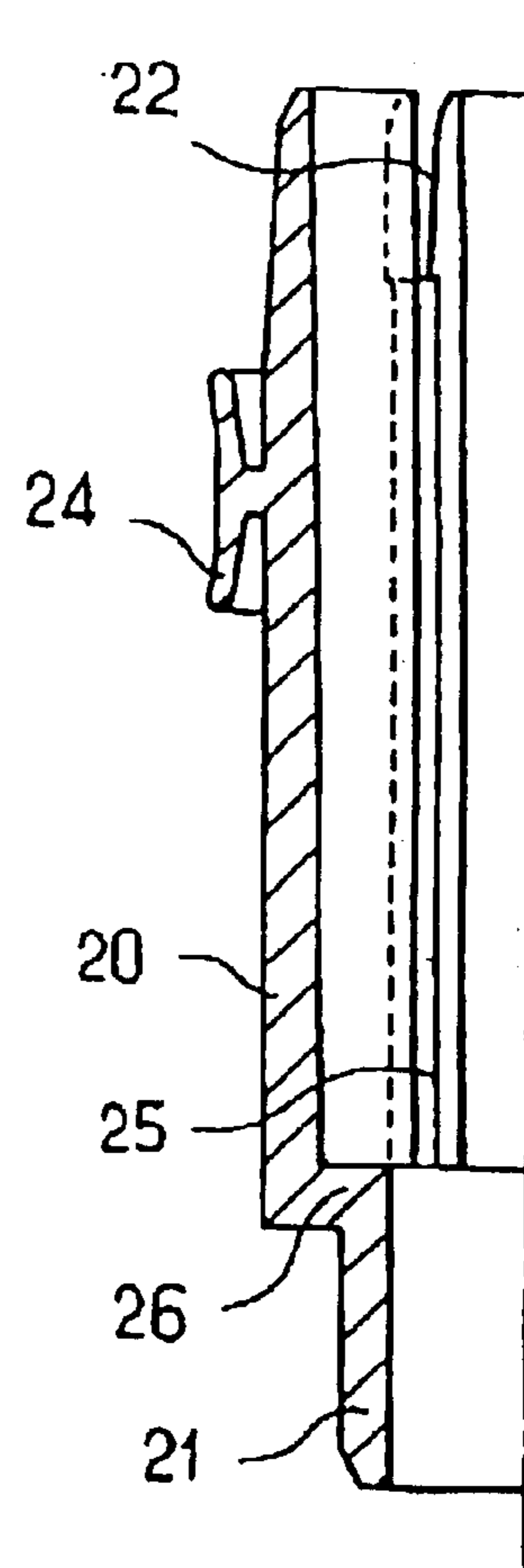

FIG. 3

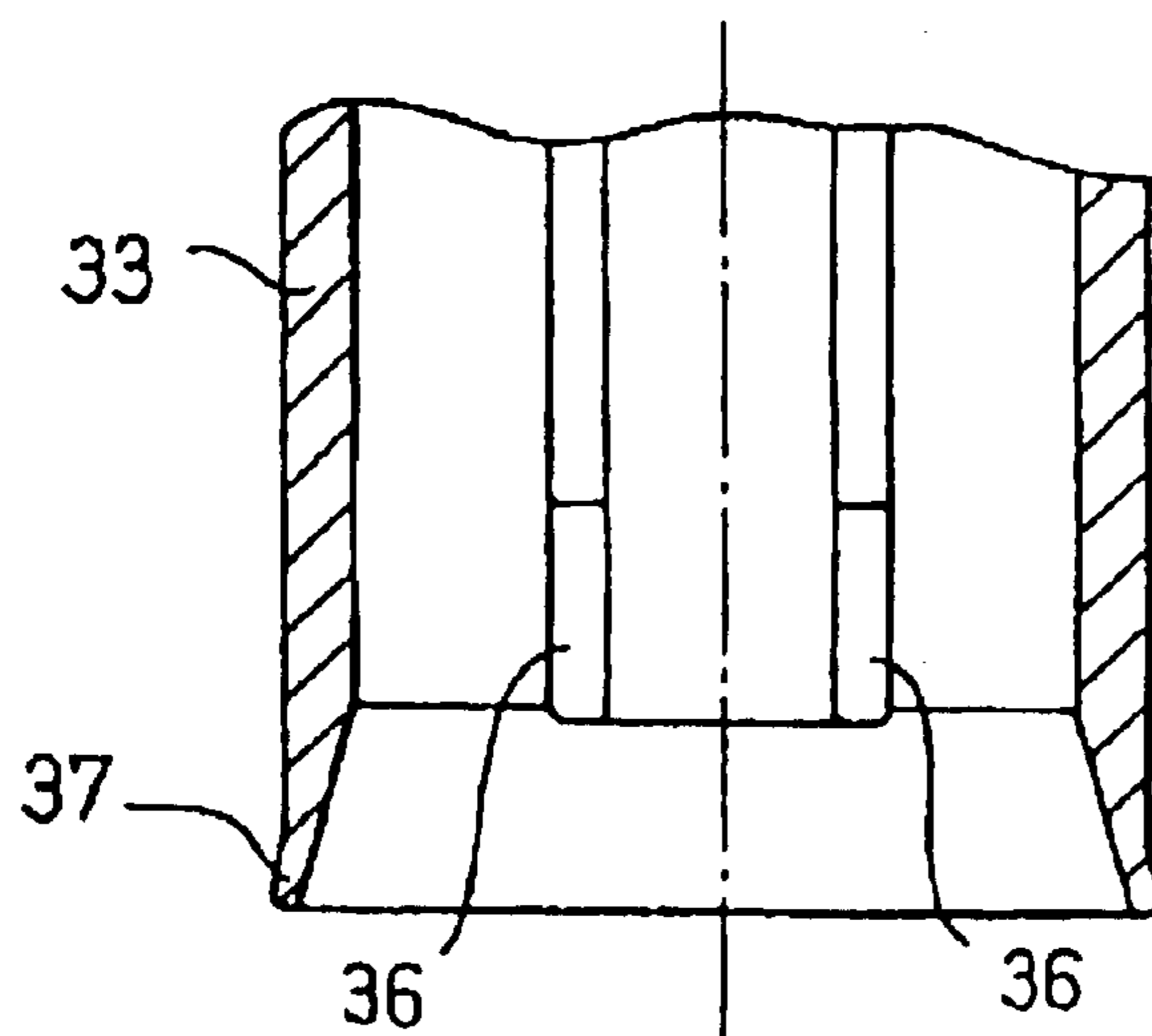

FIG. 4

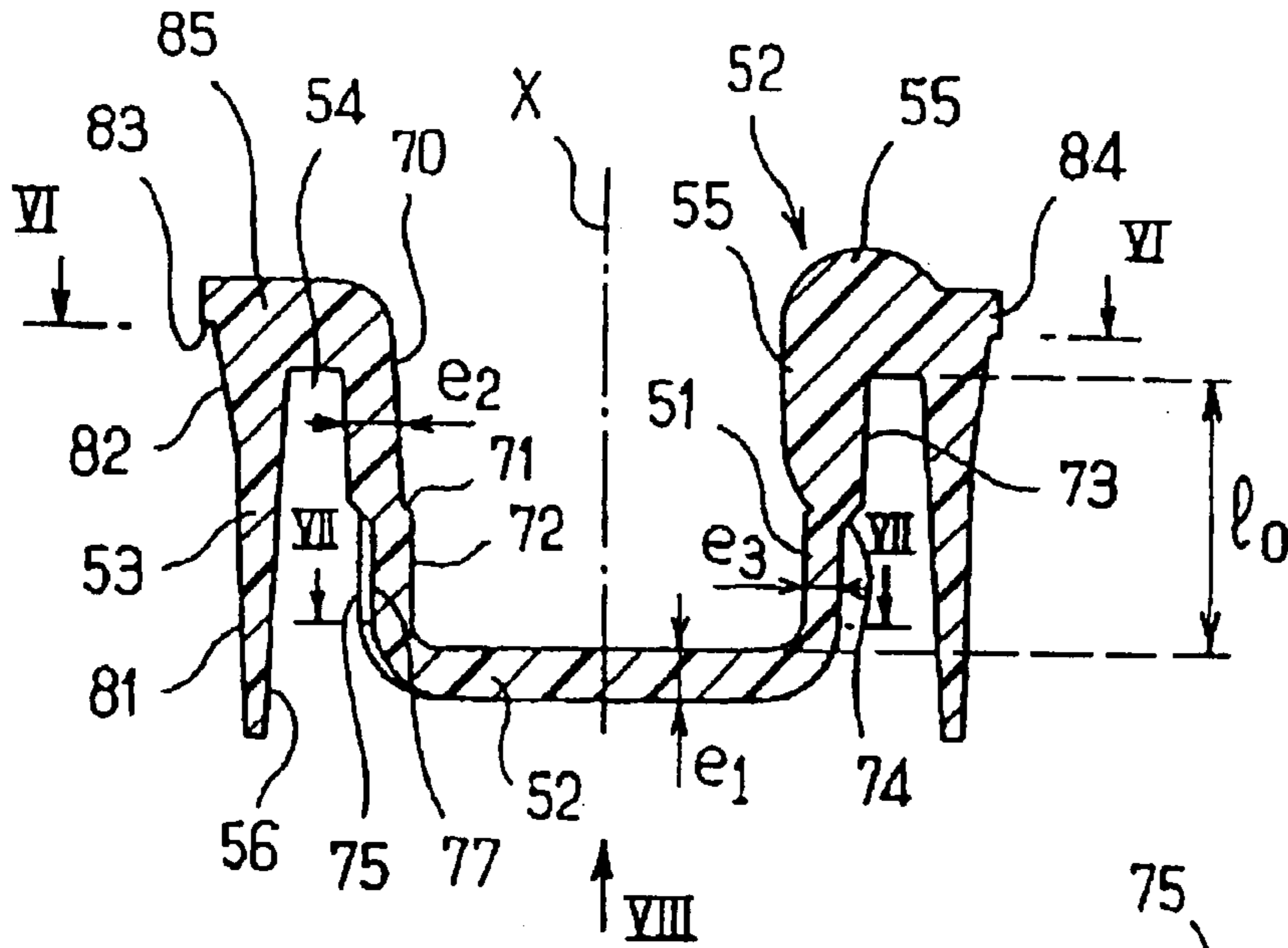

FIG. 5

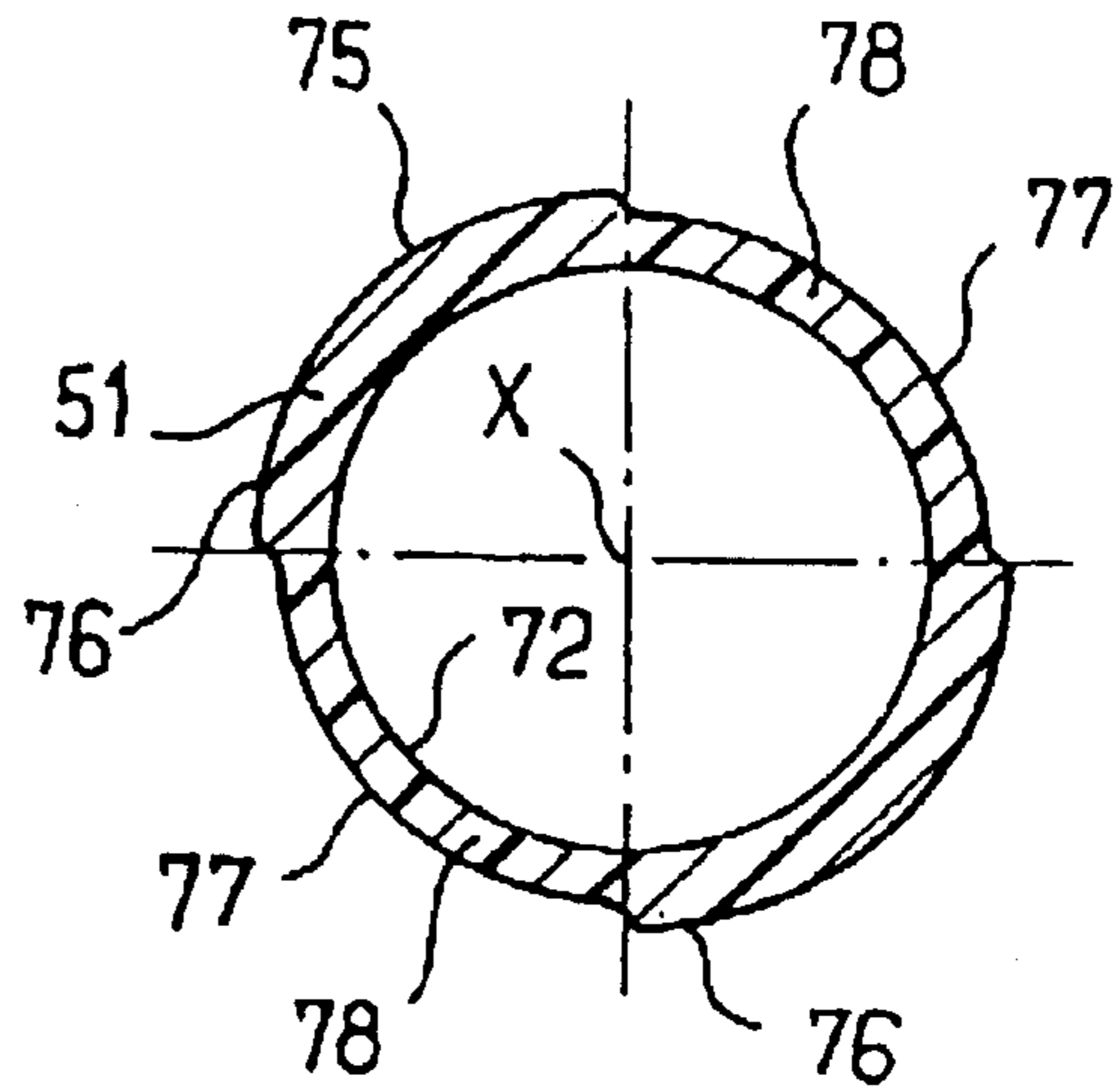

FIG. 7

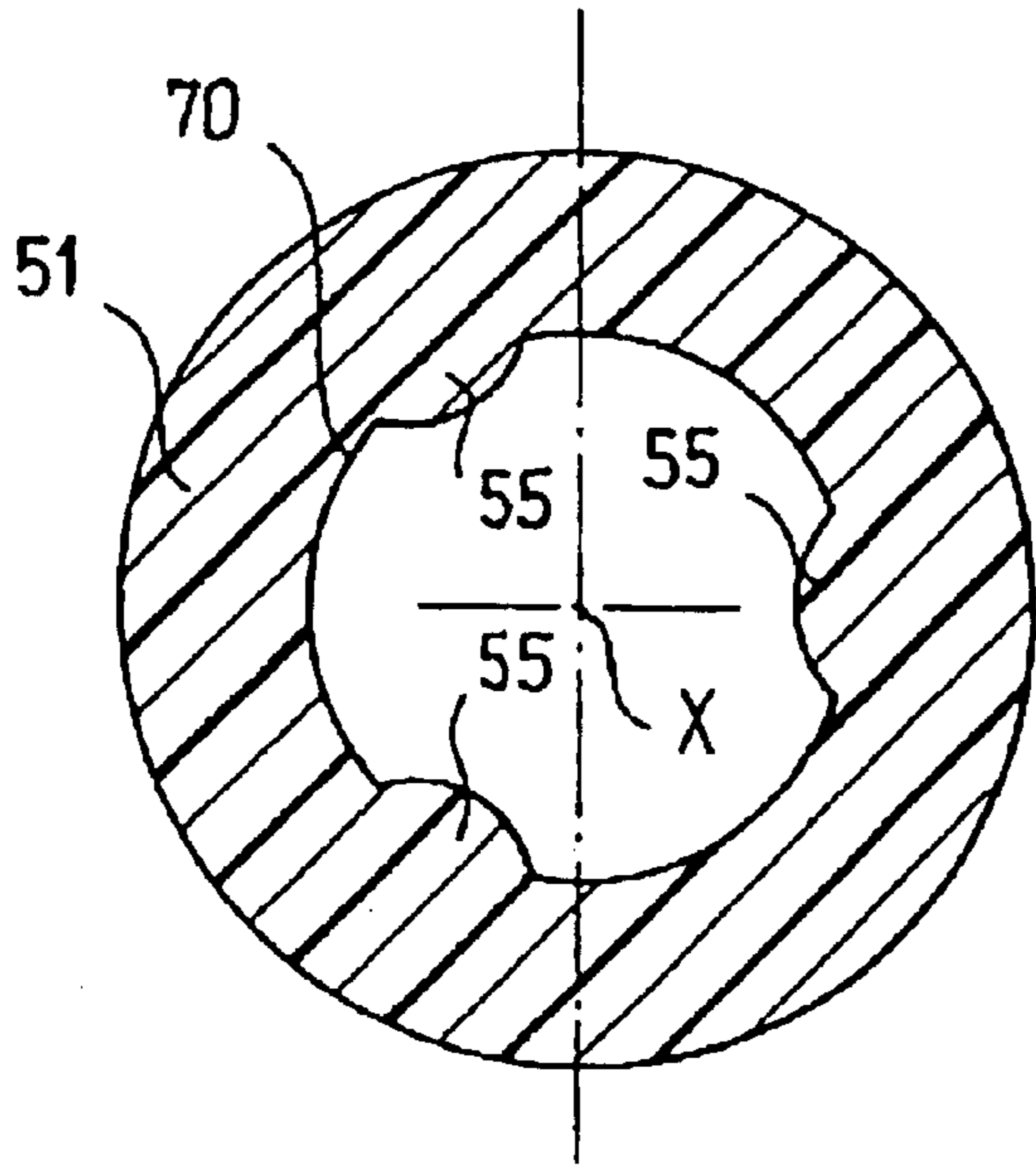

FIG. 6

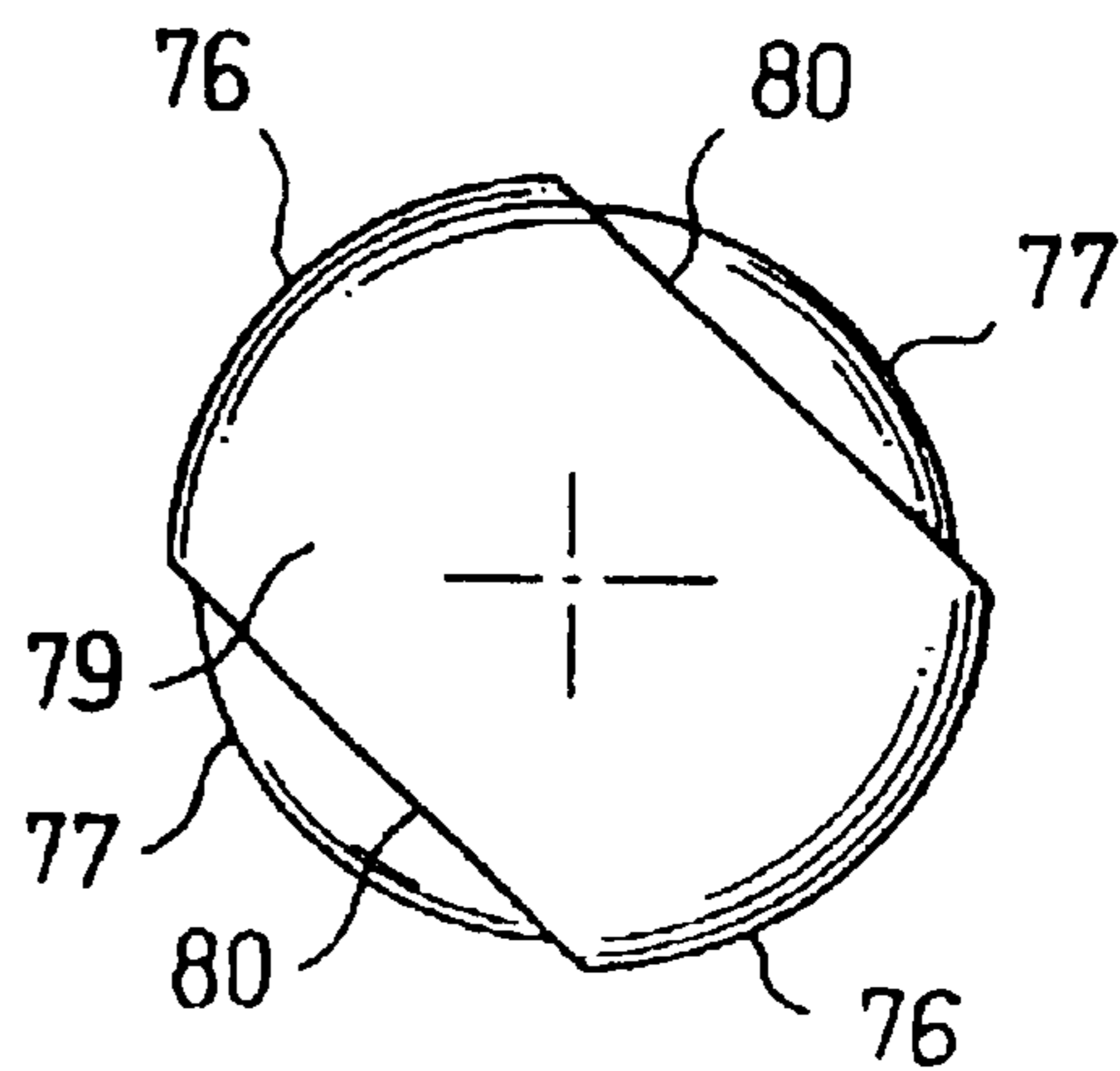

FIG. 8

FIG. 9

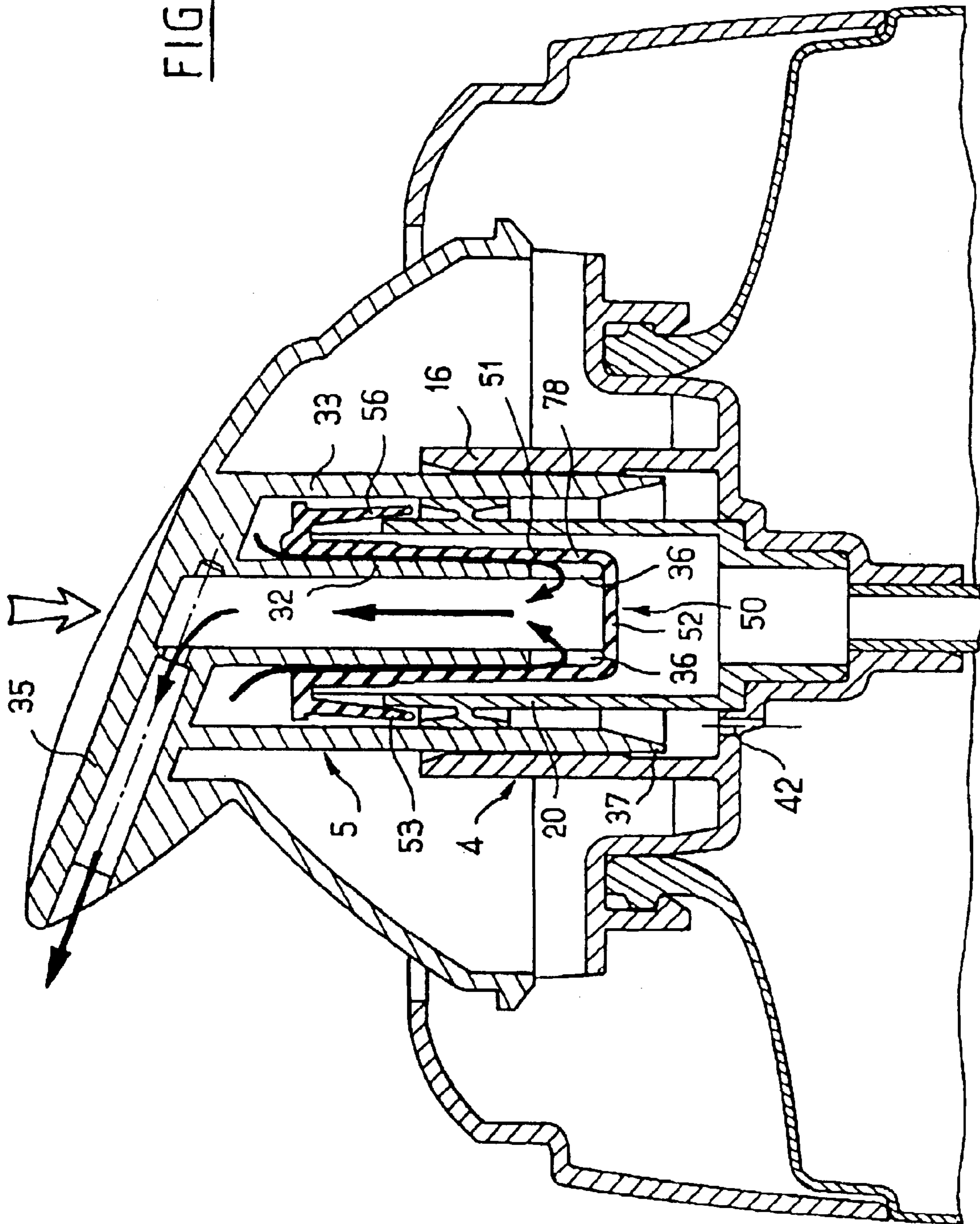
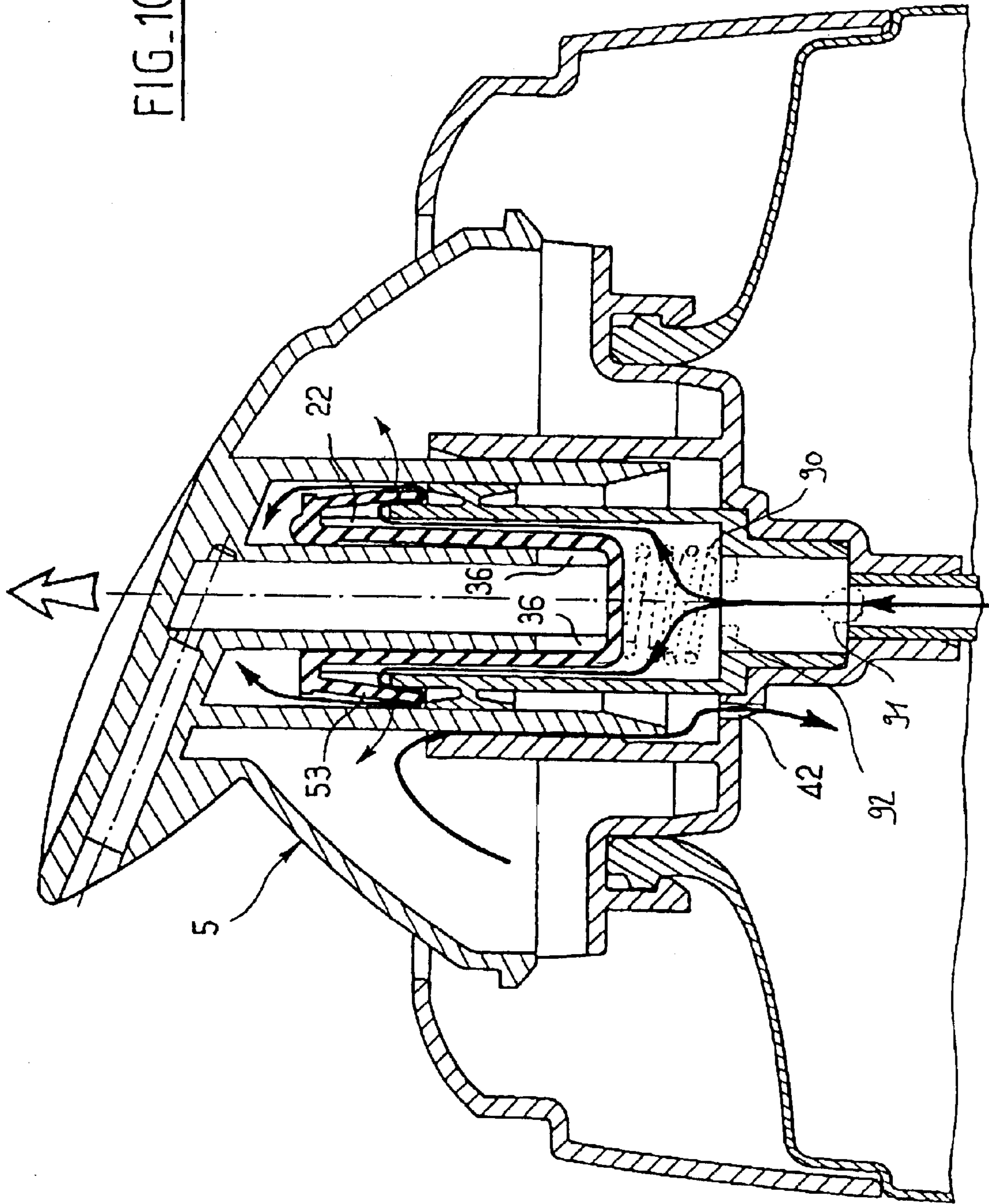

FIG. 10



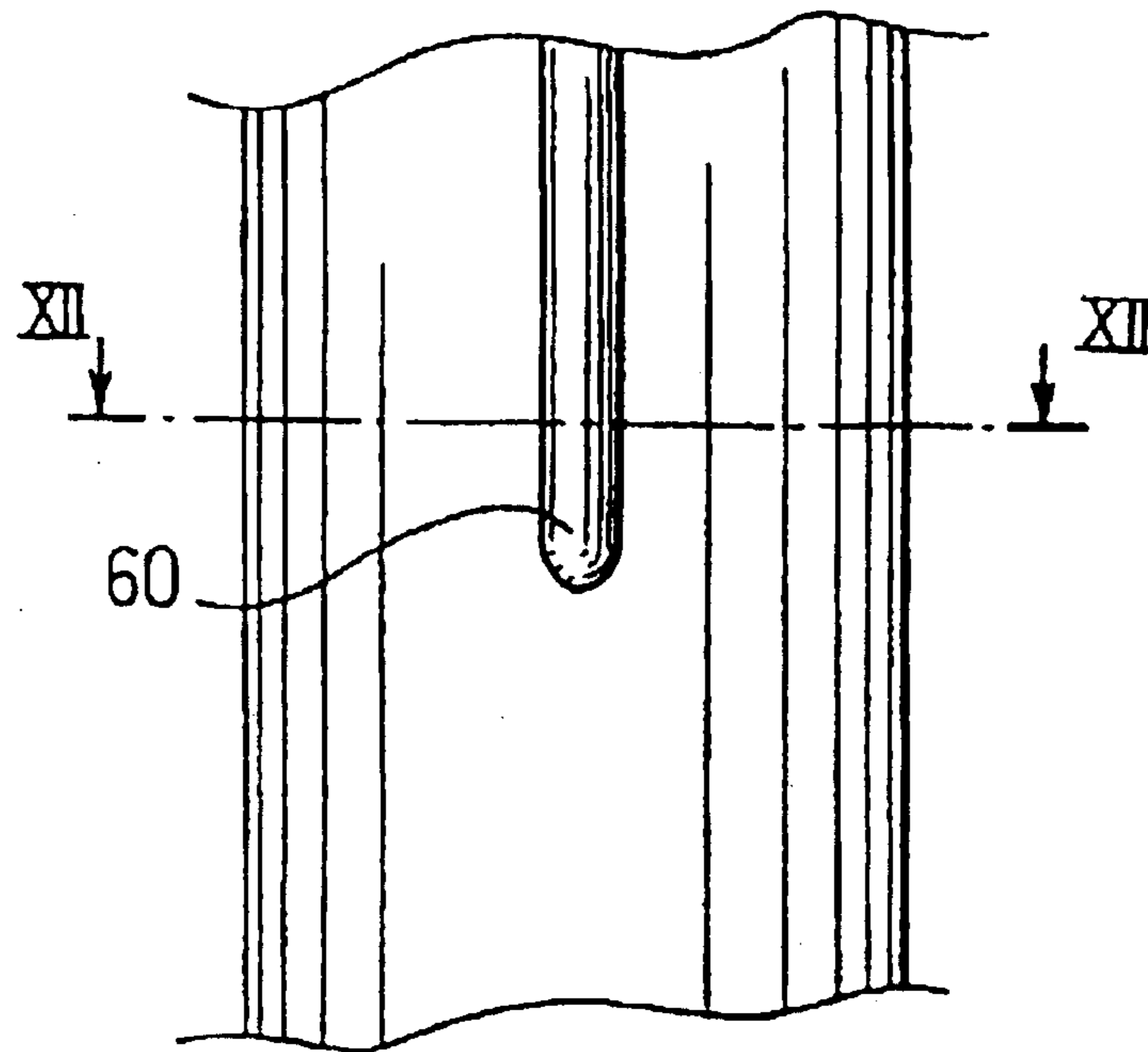

FIG. 11

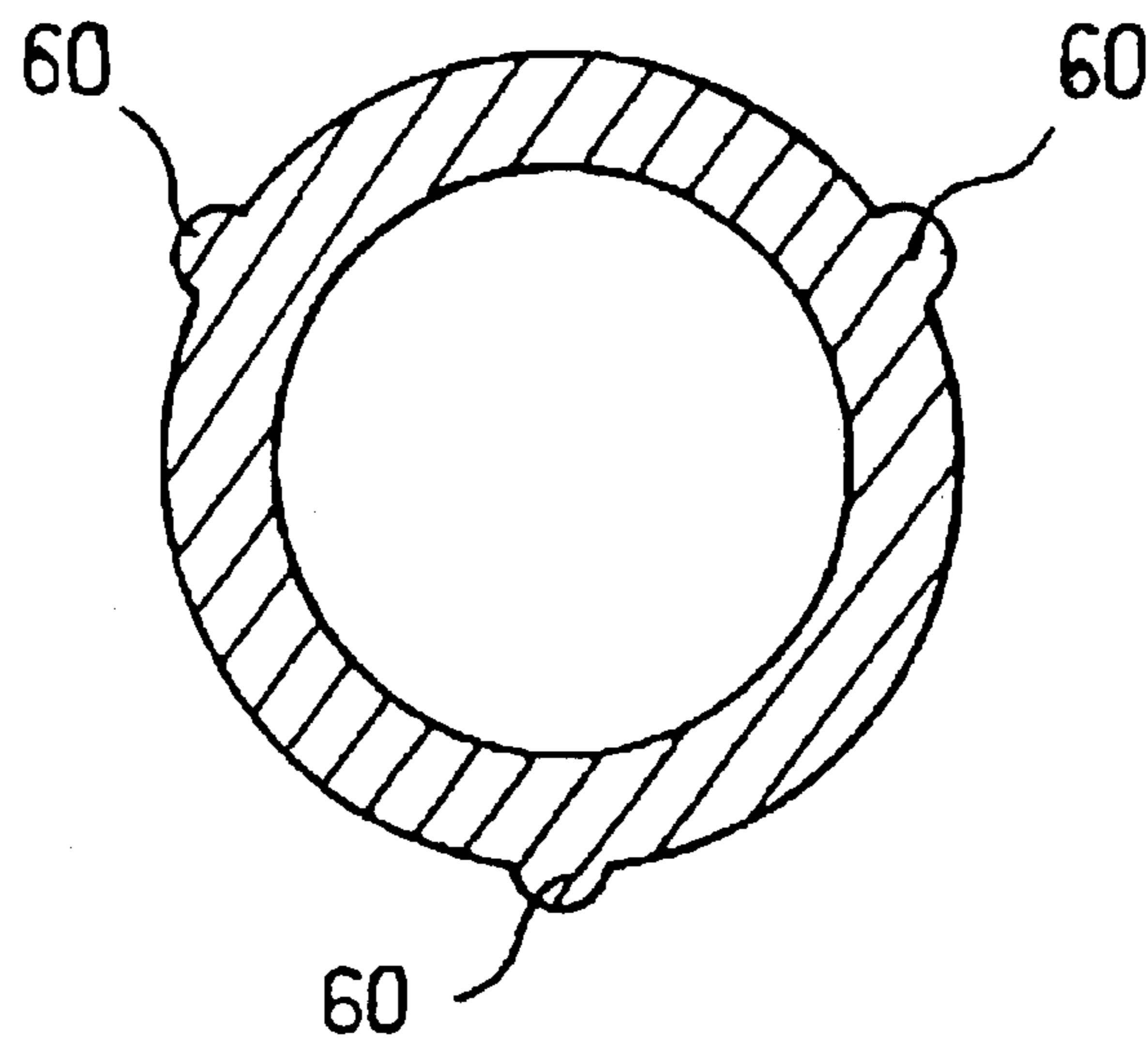

FIG. 12

1

**DIAPHRAGM PUMP COMPRISING ON AT
LEAST A PORTION OF ITS PERIPHERY
PREFERRED DEFORMATION ZONE AND A
RECEPTACLE FITTED THEREWITH**

Matter enclosed in heavy brackets [] appears in the original patent but forms no part of this reissue specification; matter printed in italics indicates the additions made by reissue.

The present invention relates to a pump and to a receptacle containing a liquid, for example a cosmetic cream, and fitted with such a pump.

BACKGROUND OF THE INVENTION

French patent 2 728 809 discloses a pump comprising a pushbutton displaceably mounted on a support which is secured to the receptacle containing the substance to be dispensed, the pushbutton having a circularly cylindrical central duct provided with radial openings at its bottom end, the support defining an annular pump chamber of variable volume around said duct. A diaphragm made of elastomer is mounted on the support. The diaphragm has a circularly symmetrical central portion in the form of a sleeve that is open at its top end and closed at its bottom end. The central duct of tile pushbutton is inserted in the diaphragm until it bears against the end wall of the sleeve.

The diaphragm thus constitutes a resilient return member enabling the pushbutton to be returned to its initial position after a quantity of substance has been dispensed.

Also, during the return movement of the pushbutton, the diaphragm isolates the pump chamber by pressing against the central duct, thereby preventing air returning into the chamber.

Such a pump presents the advantage of having only a small number of parts and thus of being of relatively low cost to manufacture.

Nevertheless, that known pump does not provide complete satisfaction, and the Applicant company has observed that the pushbutton tends to jam and/or to dispense non-uniform quantities of substance.

In addition, such a pump suffers from difficulties in priming.

OBJECTS AND SUMMARY OF THE
INVENTION

The present invention seeks to improve the reliability of the operation of a pump of the above-defined type, i.e. comprising a moving member mounted to move relative to a support, the moving member having a central duct into which the substance to be dispensed penetrates via at least one opening, the support cooperating with the moving member to define a variable volume pump chamber around said central duct, the pump also having a diaphragm having a central portion in the form of a sleeve that is open at its top end and closed at its bottom end, said central duct being inserted in said central portion, the diaphragm being organized in such a manner as to isolate the opening(s) of the pump chamber when the volume of the pump chamber increases and the substance is sucked into it.

The invention achieves this by the fact that the bottom portion of the central portion of the diaphragm presents, at least over a sector of its periphery, a preferred deformation zone, advantageously constituted by a thin zone.

By means of the preferred deformation zone(s), it is possible to make a pump in which the central portion of the

2

diaphragm exerts a relatively large return force on the moving member so as to return it to the rest position, without that preventing the substance contained in the pump chamber from reaching the central duct so as to be dispensed when the user presses on the moving member.

In a particular embodiment, the bottom portion of the central portion of the diaphragm has at least two diametrically opposite thin zones.

Still in a particular embodiment, the thin zone is formed by reducing the thickness of the diaphragm by at least 20%, and preferably by at least 25%.

Advantageously, the inside surface of the central portion of the diaphragm presents an inwardly-directed step.

Preferably, said step is situated level with the top end of the preferred deformation zone(s).

In a particular embodiment, the diaphragm has a flexible lip suitable firstly for isolating the pump chamber from the source of substance when the volume of said pump chamber decreases, and secondly for enabling substance to enter into said pump chamber when the volume thereof increases.

In a particular embodiment, said flexible lip is connected to the central portion of the diaphragm by forming a downwardly open annular trough, and the support includes an inner skirt having its top end bearing against the end wall of said trough to retain the diaphragm when the moving member is moved downwards to decrease the volume of the pump chamber.

Preferably, said inner skirt has openings at its top end, the openings being of a height that is less than the height of the flexible lip, said openings enabling the substance to reach the pump chamber when the volume thereof increases and the flexible lip moves away from the inner skirt.

In a particular embodiment, the central portion of the diaphragm is connected at its top end to an annular portion whose width and thickness are selected in such a manner as to improve retention of the diaphragm when said central portion is stretched.

Preferably, the thickness of the above-mentioned annular portion, prior to the diaphragm being assembled in the pump, is greater than or equal to the thickness of the diaphragm in its central portion.

Preferably, the above-mentioned annular portion, prior to the diaphragm being assembled in the pump, is at least 1.5 times wider than it is thick, and preferably twice as wide as it is thick.

Advantageously, the end wall of the central portion of the diaphragm, prior to the diaphragm being assembled in the pump, presents substantially the same thickness as the side wall of the central portion of the diaphragm outside said preferred deformation zone(s).

Preferably, the thickness of the end wall corresponds to within 20% to the thickness of the side wall of the central portion of the diaphragm, outside said preferred deformation zone(s), prior to the diaphragm being mounted in the pump.

In a particular embodiment, the height of the above-mentioned flexible lip is greater than or equal to the height of the central portion of the diaphragm, prior to the diaphragm being assembled in the pump.

In a particular embodiment, the flexible lip is of thickness that increases going towards the top end of the diaphragm.

In a particular embodiment, the outside surface of the flexible lip presents, starting from its bottom end, a bottom portion that is circularly cylindrical about the axis of the central portion of the diaphragm, followed by an upper

3

portion that is conical and diverges towards the top end of the diaphragm, which upper portion is connected via a shoulder to an annular rib.

Preferably, the inside diameter of the flexible lip is equal to the outside diameter of the inner skirt, ignoring manufacturing tolerances.

Also preferably, the clearance between the flexible lip and the inner skirt is negative or zero; this ensures that the flexible lip is lightly clamped against the inner skirt.

In a particular embodiment, when the moving member is at rest, the length of the central portion of the diaphragm after being assembled in the pump is greater than or equal to 1.5 times its initial length prior to assembly in the pump, and is preferably greater than or equal to twice said initial length, and more preferably greater than or equal to 3 times said initial length.

In a particular embodiment, when the moving member is fully depressed, the length of the central portion of the diaphragm is greater than or equal to twice the initial length of the diaphragm prior to assembly in the pump, is preferably greater than or equal to 3 times said initial length, and more preferably greater than or equal to 4 times said initial length.

In a particular embodiment, at least one of the diaphragm and the central duct is shaped to prevent an annular zone forming between the diaphragm and the central duct that would prevent the substance contained in the pump chamber from flowing via said central duct when the volume of the pump chamber decreases.

Preferably, at least one of the diaphragm and the central duct is shaped so as to bear against the other of the central duct and the diaphragm at predetermined locations of its periphery, at least during displacement of the moving member relative to the support.

Preferably, at least one of the diaphragm and the central duct has portions in relief against which the other of the central duct and the diaphragm comes to bear; at least during displacement of the moving member relative to the support.

This guarantees that the pump operates reliably without any risk of the moving member jamming while the volume of the pump chamber is varying.

The above-mentioned portions in relief tend to prevent the diaphragm from blocking the flow of substance coming from the pump chamber and going towards the opening(s) of the central duct via which the substance penetrates prior to being dispensed while the volume of the pump chamber is decreasing.

These portions in relief also tend to keep the central duct of the moving member on the axis of the central portion of the diaphragm, which is favorable to satisfactory operation of the pump.

In a preferred embodiment, said portions in relief are made on the diaphragm, preferably being constituted by bulges uniformly distributed around the axis of the central portion of the diaphragm at its opening, said bulges preferably extending over the top face of the diaphragm.

In a particular embodiment, the support has a pair of sealing lips bearing in leakproof manner on a tubular skirt of the moving member, said tubular skirt being downwardly open and extending around the central duct concentrically thereabout, said tubular skirt also defining the pump radially outer wall of the pump chamber.

In a particular embodiment, the inner skirt is a portion of a piece fitted to the remainder of the support.

In a preferred embodiment, the central duct of the moving member is provided with at least one radial opening at its bottom end.

4

In a preferred embodiment, the moving member constitutes a pushbutton, the central duct being integrally formed with a dispenser endpiece.

In a particular embodiment, the tubular skirt of the moving member slides inside a guide skirt of the support, co-operating with the inner skirt of the support to define an upwardly open annular trough which communicates with the source of substance via at least one air intake orifice, the tubular skirt of the moving member bearing in leakproof manner against side guide skirt when the moving member is at rest and the volume of the pump chamber is at a maximum.

The diaphragm can be made of a nitrile elastomer or of a silicone elastomer.

In a particular embodiment, the pump has a return spring for returning the moving member towards an initial position after a quantity of substance has been dispensed.

Advantageously, the return spring is constituted by a helical spring working in compression.

Preferably, the spring is disposed on the axis of the membrane so that the top end of the spring bears against the bottom end of the central portion of the membrane.

The presence of a return spring is advantageous since it makes it possible to have a wider choice of materials for constituting the membrane since the membrane need not be prestressed or it can be prestressed, but only to a relatively small extent.

The presence of a spring also enlarges the range of substance that can be dispensed, since it becomes easier to find a membrane material that is compatible with the substance for dispensing.

The invention also provides a receptacle fitted with a pump as defined above.

BRIEF DESCRIPTION OF THE DRAWINGS

Other characteristics and advantages of the present invention will appear on reading the following detailed description of a non-limiting embodiment of the invention and of a variant implementation, and on examining the accompanying drawings, in which:

FIG. 1. is a diagrammatic view of the top portion of a receptacle fitted with a pump of the invention;

FIGS. 2 and 3 show the Inner skirt of the support in isolation;

FIG. 4 shows a fragment of the bottom end of the tubular skirt of the moving member in isolation;

FIG. 5 is a diagrammatic axial section showing in isolation the diaphragm for fitting to the pump 1, prior to being assembled in the pump;

FIG. 6 is a section on section line VI-VI of FIG. 5;

FIG. 7 is a section on section line VII-VII of FIG. 5;

FIG. 8 is a view from beneath of the central portion of the diaphragm seen looking along arrow VIII of FIG. 5;

FIG. 9 shows how the pump operates when the pushbutton is depressed;

FIG. 10 shows how the pump operates when the pushbutton is released;

FIG. 11 is a fragmentary and diagrammatic view of the central duct of a pushbutton in a variant implementation of the invention; and

FIG. 12 is a cross-section on section line XII-XII of FIG. 30.

MORE DETAILED DESCRIPTION

FIG. 1 shows a receptacle 1 comprising a tank forming body 2 of which only the top end is shown in the drawing, defining a neck 3 on which a support 4 is snap-fastened.

5

The support **4** guides a pushbutton **5** in sliding along an axis X, and it serves to mount a removable protective cap **6** covering the pushbutton **5** prior to first use.

The support **4** has a sealing skirt **7** bearing in leakproof manner against the inside surface of the neck **3**.

The sealing skirt **7** is extended radially, firstly outwards by fixing tabs **8** snap-fastened on an annular rim **9** of the neck **3**, and secondly inwards in the form of a stepped wall **10** defining an endpiece **12** for connecting a dip tube **13**, shown in part in the drawing.

An outer skirt **15** and a guide skirt **16** are integrally formed together with the sealing skirt **7**, the fixing tabs **8**, and the stepped wall **10** by molding a plastics material.

The outer skirt **15** extends around the neck **3** of the receptacle and presents a shoulder **17** on which the protective cap **6** bears.

The top edge **18** of the outer skirt **15** holds the pushbutton **5** at rest, as explained below.

The support **4** has an inner skirt **20** constituted by a separate part, with a bottom end **21** having a shoulder that is engaged by force into the stepped wall **10**.

The inner skirt **20** has a substantially tapering top end provided with openings **22**, as can be seen more particularly in FIGS. **2** and **3**.

In the example described, these openings **22** are in the form of slots running parallel to the axis X and extended downwards by grooves **25** occupying the radially inner surface of the inner skirt **20** as far as a step **26**. A pair of annular sealing lips **24** are integrally formed with the inner skirt **20** by molding a plastics material.

The pushbutton **5** has an outer skirt **30** provided at its bottom end with teeth **31**, which teeth come into abutment against the top edge **18** of the outer skirt **15** of the support **4** when the pushbutton **5** is at rest in its high position, as shown in FIG. **1**.

The pushbutton **5** has a central duct **32** on the axis X, and a concentric tubular skirt **33** defining an annular pump chamber **34** around the central duct **32**.

The outer skirt **30**, the tubular skirt **33**, and the central duct **32** are formed integrally with a dispenser endpiece **35** communicating internally with the central duct **32** by holding a plastics material.

At its bottom end, the central duct **32** has radial openings **36**, there being four of them in the example described, which openings are uniformly distributed around the axis X. Each opening **26** is in the form of a narrow slot.

The bottom end of the tubular skirt **33** forms a sealing lip **37** extending radially outwards to a small extent, as is shown more particularly in FIG. **4**. The bottom portion of the guide skirt **16** of the support **4** has a shallow annular setback **41** in its radially inner surface.

When the pushbutton **5** is in the high position, the sealing lip **37** presses in leakproof manner against the circularly cylindrical surface **40** of the top portion of the guide skirt **16**, as shown in FIG. **1**.

The inside of the receptacle is thus isolated from ambient air, which is favorable to good conservation of the substance to be dispensed.

When the pushbutton **5** is pressed down, the sealing lip **37** ceases to bear in leakproof manner against the guide skirt **16** because of the annular setback **41**, thereby enabling the trough formed between the inner skirt **20** and the guide skirt **16** to communicate with the outside.

An air intake orifice **42** is formed in the bottom of this trough to allow air to penetrate into the receptacle progressively as it empties.

6

The inner skirt **20** serves as a mount for a diaphragm having a sleeve-shaped central portion **51** about the axis X which is open at its top end and closed at its bottom end by an end wall **52**.

This central portion **51** is extended radially outwards by a flexible annular lip **53**, as can be seen more particularly in FIGS. **5** and **6**.

By connecting with the central portion **51**, this flexible lip **53** forms an annular trough **54** in which the top end of the inner skirt **20** is inserted until its free edge bears against the end wall of said trough.

The flexible lip **53** is made in such a manner as to clamp lightly on the inner skirt **20**.

The height of the flexible lip **53** is greater than the height of the openings **22**, and the flexible lip **53** is suitable at rest for bearing in leakproof manner via its inner surface **56** against the radially outer surface of the inner skirt **20** beyond the openings **22**, as shown in FIG. **1**.

The flexible lip **53** can deform radially outwards to enable substance to reach the pump chamber **34**, as described in greater detail below.

At the opening of its central portion **51**, the diaphragm **50** has portions in relief that are not circularly symmetrical about the axis X, i.e. in this particular example bulges **55** whose function is explained below.

In the embodiment described, there are three of these bulges **55** and they are uniformly distributed angularly about the axis X, as can be seen in FIG. **6**.

Each of these bulges **55** projects from the radially inner surface of the central portion **51** over about half the height thereof (prior to being assembled in the pump) starting from the top end, and each extends radially outwards over the top face of the diaphragm **50** so as substantially to overlie the trough **54**, as can be seen in FIG. **5**.

Each of the bulges **55**, when observed in section in a cross-section plane, also presents a section that is convex towards the axis X, as shown in FIG. **6**.

The inside surface of the central portion **51** of the diaphragm has a top portion **10** that is slightly conical towards the end wall **52**.

The bulges **55** are formed on this conical portion **10**, as can be seen in FIG. **5**.

The conical surface **70** is connected via an inwardly-directed step **71** to a surface **72** that is circularly cylindrical about the axis X.

The outer surface of the central portion **51** of the diaphragm has a conical portion **73** parallel to the top conical portion **70** and connecting via a step **74** parallel to the step **71** to a surface **75** formed by alternating sectors **76** and **71** that are circularly cylindrical about the axis X, but that has different diameters.

More particularly, and as can be seen in FIG. **7**, there are two sectors **77** each occupying 90°, they are diametrically opposite, and they are of a diameter that is smaller than the diameter of the sectors **76**.

The sectors **77** co-operate with the cylindrical inside surface **72** to define two diametrically opposite thin zones **78** whose function is described below. The sectors **76** are united by a strip **79** extending over the bottom face of the end wall **70** and having parallel sides **80**, as can be seen in FIG. **8**.

The inside surface **56** of the flexible lip **53** is conical, converging upwards, as can be seen in FIG. **5**.

Starting from its bottom end, the outside surface of the flexible lip **53** has a bottom portion **81** that is substantially

circularly cylindrical about the axis X, followed by an upwardly divergent conical upper portion **82**, said upper portion **82** being connected via a shoulder **83** to an annular rib **84**.

As can be seen in FIG. 5, the annular portion **85** which unites the flexible lip **53** to the central portion **51** is relatively wide and thick, thus making it possible to ensure that the top end of the central portion **51** is indeed held stationary relative to the inner Skirt **20** when the central portion **51** is stretched.

In the embodiment described, the annular portion **85** is about twice as wide as it is thick, outside the bulges

The thickness e_1 of the end wall **52** in the example described is substantially the same as the thickness e_2 of the side wall of the central portion **51** between the surfaces **73** and **70**, and outside the bulges **55**.

The thickness e_3 of the central portion **51** measured between the surfaces **72** and **75** is about 0.75 times the thickness e_2 in the embodiment described.

By way of example, in the embodiment, the thickness e_1 is 0.55 mm, the thickness e_2 is 0.55 mm, and the thickness e_3 is 0.4 mm (thickness measured prior to the diaphragm being assembled in the pump).

When the pushbutton **5** is at rest, as shown in FIG. 1, the length of the central portion **51** of the diaphragm is about 3 times the initial length l_0 of the central portion **51**, i.e. lengthening reaches 200%.

By way of example, when the diaphragm **50** is not assembled, the length l_0 measured between the end wall of the trough **54** and the top face of the end wall **53** is about 3 mm, and when the diaphragm is in place in the pump and the pushbutton is at rest, as shown in FIG. 1, the length of the central portion **51** is about 9 mm.

In the example described, at the end of the depression stroke of the pushbutton **5**, the central portion **51** is lengthened by 350%.

In the example under consideration, the length of the central portion **51** is then about 13.5 mm, and down stroke of the pushbutton **b** being 4.5 mm.

During assembly, the central duct **32** of the pushbutton **5** is inserted into the central portion **51** of the diaphragm **50** until its bottom end bears against the end wall **52** of the diaphragm **50**, as shown in FIG. 1.

In the example described, the bulges **55** then bear against the circularly cylindrical surface of the central duct **32**. Nevertheless, in general, it is not essential for the bulges **55** to bear against the central duct **32** when the pushbutton is at rest.

While the pushbutton **5** is at rest, the central portion **51** of the diaphragm **50** is under tension, so as to hold the teeth **31** in abutment against the top edge **18** of the outer skirt **15**.

The pair of sealing lips **24** bear in leakproof manner against the radially inner surface of the tubular skirt **33** regardless of the up or down movement of the pushbutton **5**.

The radially inner surface of the central portion **51** of the diaphragm closes the radial openings **36** in the central duct **32**.

At rest, the inside surface **56** of the flexible lip comes to bear against the inner skirt **20**.

The support **4**, the pushbutton **5**, and the diaphragm **50** constitute a pump which operates as follows.

When the user presses down the pushbutton **5**, as shown in FIG. 9, the central duct **32** drives the end wall **52** of the diaphragm **50** downwards, with the diaphragm deforming

elastically and stretching so as to accompany the downward movement of the central duct **32**.

It is assumed that the pump is primed, i.e. that the pump chamber **34** is full of substance.

During the downward movement of the pushbutton **5**, the substance contained in the pump chamber **34** is expelled between the central duct **32** and the central portion **51** of the diaphragm, and it reaches the radial openings **36** of the central duct **32** and then the dispenser endpiece **35**.

The inside surface **56** of the flexible lip **53** bears in leakproof manner against the inner skirt **20** during the downward movement of the pushbutton **5**.

On reaching the annular setback **41** after the pushbutton **5** has been pushed down a certain distance, the sealing lip **37** of the tubular skirt **33** of the pushbutton **5** ceases to bear in leakproof manner against the guide skirt **16**, thereby making communication possible between the inside of the receptacle and the outside via the air intake orifice **42** and the clearance that exists between the guide skirt **16** and the tubular skirt **33**.

Between them, the bulges **55** leave passages for the substance and prevent a leakproof annular barrier zone forming between the central duct **32** and the central portion **51** of the diaphragm **50** which might not be overcome by the pressure of the substance, so it is ensured that the substance can reach the radial openings **36**, with the diaphragm **50** moving a little away from the central duct **32** in the vicinity of the top ends of the openings **36** under the effect of the pressure in the substance.

The existence of the thin zones **78** favors outward deformation of the side wall of the central portion **51** so as to allow the substance to penetrate in the radial openings **36**.

The existence of the step **71** enables the substance to move down more easily along the central duct **32** as far as the radial openings **36** without running the risk of substance flow becoming blocked by the diaphragm **50**.

The bulges **55** tend to hold the central duct **32** coaxially relative to the inner skirt **20** and to guarantee that the diaphragm hooks onto the inner skirt **20**.

When the user releases the pushbutton **5**, the pushbutton is urged upwards by the central portion **51** of the diaphragm which tends to return to its initial shape.

Because of the thin zones **78**, the central portion **51** can present relatively great thickness of material outside these zones, thereby enabling the central portion **51** to stretch while the diaphragm **50** is being put into place in the pump sufficiently to ensure that the return force obtained will enable the pushbutton **5** to rest without any risk of jamming.

During the return movement of the pushbutton **5**, the central portion **51** of the diaphragm **50** closes the radial openings **36**, and the suction which is created in the pump chamber **34** causes the flexible lip **53** of the inner skirt **20** to move away, and draws substance in from the receptacle.

The step **71** is situated above the top ends of the radial openings **36** so that during the return movement of the pushbutton **5**, the surface **72** of the central portion **51** can close the radial openings **36**.

The substance reaches the pump chamber **34** by flowing via the grooves **25** of the inner skirt **20** along the central portion **51** of the diaphragm **50**, passing through the inner skirt **20** via the openings **22**, and then passing round the flexible lip **53** and rising outside it, as shown in FIG. 10.

While the pushbutton **5** is rising, air can penetrate into the receptacle via the clearance that exists between the guide skirt **16** and the tubular skirt **33** and via the air intake orifice

42, and this continues until the sealing lip 37 bears again in leakproof manner against the guide skirt 16 when the pushbutton 5 reaches its high position, as explained above.

It will be observed that the relatively small thickness of the end wall 52 makes it possible to prevent the elastomer material from which the diaphragm is made rolling into a rim under the thrust of the central duct 32, where such a rim could press against the inside surface of the inner skirt 20 and give rise to friction that is harmful to proper operation of the pump.

Naturally, the invention is not restricted to the embodiment described above.

In particular, it is possible to use a diaphragm in which the radially inner surface of the top portion of the central portion is circularly symmetrical, with the bulges 55 being replaced by bulges 60 formed on the top portion of the central duct 32, as shown in FIGS. 11 and 12.

It is also possible to assist or cause the pushbutton to undertake its return movement by means of a helical spring 90 as shown in dashed lines in FIG. 10.

The spring is received inside the inner skirt 20, it works in compression, and its bottom end bears against the setback 26 while its top end bears against the bottom face of the end wall 52 of the membrane.

It is also possible to place a non-return valve upstream from the membrane, said valve opening while the substance is being sucked into the pump chamber and presenting a leak so as to avoid preventing the moving member from moving while a quantity of substance is being dispensed.

The valve can be implemented, for example, by means of a ball 91 as shown in dashed lines in FIG. 8, with the endpiece 12 serving as a seat.

Portions in relief 92 are formed on the inner surface of the inner skirt so as to hold the ball 91 close to its seat.

The ball 91 is selected to be very rough so as to create a leak that ensures that the downward movement of the central portion of the membrane is not impeded while a quantity of substance is being dispensed.

The ball 91 makes it possible to prime the pump by actuating the pushbutton a few times.

The membrane may also be made out of at least two different materials.

Thus, to make the flexible lip 53, it is possible to use a material that is softer than the material used for making the spring-forming portion 51.

By way of example, the same elastomer can be used but with differing quantities of filler.

By using different materials, it is possible to use a material which is relatively hard for the central portion 51, which is favorable to obtaining a good spring effect, without thereby impeding operation of the flexible lip 53.

In an embodiment that is not shown, a helical spring is placed around the central duct and has its bottom end bearing against the top end of the membrane while its top end bears against the pushbutton 5.

What is claimed is:

1. A pump [of type] comprising:

a support,

a moving member mounted to move relative to [a] said support, the moving member having a central duct into which [the] a substance to be dispensed penetrates via at least one opening, the support cooperating with the moving member to define a variable volume pump chamber around said central duct,

[the pump also having] a diaphragm having a [central portion in the form of] a sleeve with a top and a lower ends that is open at [its] the top end and closed at [its bottom] the lower end, said central duct being inserted in said [central portion] sleeve, the diaphragm being [organized in such a manner as] configured to isolate the at least one opening[s] of the pump chamber when the volume of the pump chamber increases [and] and the substance is sucked [into it] therein, wherein the [bottom] lower portion of the [central portion of the diaphragm] sleeve presents, at least over a sector of its periphery, [a] at least one preferred deformation zone.

2. A pump according to claim 1, wherein said at least one preferred deformation zone is constituted by a thin zone.

3. A pump according to claim 2, wherein [the bottom] a portion of the [central portion of the diaphragm] sleeve has at least two diametrically opposite thin zones.

4. A pump according to claim 2, wherein the thin zone is formed by reducing the thickness of the diaphragm by at least 20%.

5. A pump according to claim 1, wherein the inside surface of the [central portion of the diaphragm presents] sleeve comprises an inwardly-directed step.

6. A pump according to claim 5, wherein said step is situated level with [the top] the first end of the preferred deformation zone(s).

7. A pump according to claim 1, wherein the diaphragm has a flexible lip suitable firstly for isolating the pump chamber from the source of substance when the volume of said pump chamber decreases, and secondly for enabling substance to enter into said pump chamber when the volume thereof increases.

8. A pump according to claim 7, wherein said flexible lip is connected to the [central portion of the diaphragm] sleeve by forming a downwardly open annular trough, and wherein the support [includes] comprises an inner skirt having [its] the top end bearing against [the] an end wall of said trough to retain the diaphragm when the moving member is moved downwards to decrease the volume of the pump chamber.

9. A pump according to claim 8, wherein the inner skirt is a portion of a piece fitted to the remainder of the support.

10. A pump according to claim 9, wherein the support has a pair of sealing lips bearing in leakproof manner on a tubular skirt of the moving member, said tubular skirt being downwardly open and extending around the central duct concentrically thereabout, said tubular skirt also defining the pump radially outer wall of the pump chamber.

11. A pump according to claim 10, wherein the tubular skirt of the moving member is configured to slide[s] inside a guide skirt of the support, co-operating with the inner skirt of the support to define an upwardly open annular trough which communicates with the source of substance via at least one air intake orifice, the tubular skirt of the moving member bearing in leakproof manner against said guide skirt [(16)] when the moving member is at rest and the volume of the pump chamber is at a maximum.

12. A pump according to claim 10, wherein said inner skirt has openings at [its] the top end, the openings being of a height that is less than the height of the flexible lip, said openings enabling the substance to reach the pump chamber when the volume thereof increases and the flexible lip moves away from the inner skirt under the effect of thrust from the substance flowing towards the pump chamber.

13. A pump according to claim 8, wherein the height of the flexible lip is greater than or equal to the height of the [central portion of the diaphragm] sleeve, prior to the diaphragm being assembled in the pump.

11

14. A pump according to claim 8, wherein the flexible lip is of thickness that increases going towards the top end of the [diaphragm]sleeve.

15. A pump according to claim 8, wherein the outside surface of the flexible lip presents, starting from its bottom end, a [bottom] first portion that is circularly cylindrical about the axis of the central portion of the diaphragm, followed by [an upper] a second portion that is conical and diverges towards the top end of the [diaphragm]sleeve, which [upper] second portion is connected via a shoulder to an annular rib.

16. A pump according to claim 8, wherein the inside diameter of the flexible lip is equal to the outside diameter of the inner skirt, ignoring manufacturing tolerances.

17. A pump according to claim 16, wherein the clearance between the flexible lip and the inner skirt is negative or zero.

18. A pump according to claim 1, wherein the [central portion of the diaphragm] sleeve is connected at [its] the top end to an annular portion whose width and thickness are selected in such a manner as to improve retention of the diaphragm when said [central portion] sleeve is stretched.

19. A pump according to claim 18, wherein the thickness of said annular portion, prior to the diaphragm being assembled in the pump, is greater than or equal to the thickness of the [diaphragm in its central portion]sleeve.

20. A pump according to claim 18, wherein said annular portion, prior to the diaphragm being assembled in the pump, is at least 1.5 times wider than it is thick.

21. A pump according to claim 1, [wherein the] said sleeve having an end wall [of the central portion of the diaphragm], wherein said end wall of the sleeve, prior to the diaphragm being assembled in the pump, presents substantially the same thickness as [the] said side wall of the [central portion of the diaphragm] sleeve outside said [preferred] at least one deformation zone(s).

22. A pump according to claim 1, said sleeve having an end wall, wherein the thickness of the end wall of the [central portion of the diaphragm] sleeve corresponds to within 20% of the thickness of the side wall of the [central portion of the diaphragm] sleeve outside said [preferred] at least one deformation zone(s), prior to the diaphragm being assembled in the pump.

23. A pump according to claim 1, said sleeve having an initial length prior to assembly in the pump wherein, when the moving member is at rest, the length of the [central portion of the diaphragm] sleeve after being assembled in the pump is greater than or equal to 1.5 times its initial length [prior to assembly in the pump].

24. A pump according to claim 1, said sleeve having an initial length prior to assembly in the pump wherein, when the moving member is fully depressed, the length of the [central portion of the diaphragm] sleeve is greater than or equal to twice the initial length of the [diaphragm prior to assembly in the pump]sleeve.

25. A pump according to claim 1, wherein at least one of the diaphragm and the central duct is [shaped] configured to prevent an annular zone forming between the diaphragm [and] and the central duct that would prevent the substance contained in the pump chamber from flowing via said central duct when the volume of the pump chamber decreases.

26. A pump according to claim 25, wherein at least one of the diaphragm and the central duct is [shaped so as] configured to bear against the other of the central duct and the diaphragm at predetermined locations of its periphery, at least during displacement of the moving member relative to the support.

12

27. A pump according to claim 26, wherein at least one of the diaphragm and the central duct has portions in relief against which the other of the central duct and the diaphragm comes to bear, at least during displacement of the moving member relative to the support.

28. A pump according to claim 27, wherein said portions in relief are made on the diaphragm.

29. A pump according to claim 1, wherein the central duct of the moving member is provided with at least one radial opening at [its bottom] an end.

30. A pump according to claim 1, wherein the moving member constitutes a pushbutton, the central duct being integrally formed with a dispenser endpiece.

31. A pump according to claim 1, wherein the diaphragm is made of at least one of a nitrile elastomer [or of] and a silicone elastomer.

32. A pump according to claim 1, having a return spring for retuning the moving member towards an initial position after a quantity of substance has been dispensed.

33. A pump according to claim 32, wherein the return spring is constituted by a helical spring working in compression.

34. A pump according to claim 33, said diaphragm having an axis wherein the spring is disposed on the axis of the [membrane] diaphragm so that the top end of the spring bears against the [bottom end of the central portion of the membrane] lower end of the sleeve.

35. A pump according to claim 1, including a nonreturn valve upstream from the [membrane]diaphragm, said valve opening while substance is being sucked into the pump chamber, and presenting a leak so as to avoid preventing displacement of the moving member while a quantity of substance is being dispensed.

36. A pump according to claim 1, wherein the [membrane] diaphragm is made of at least two different materials.

37. A pump according to claim 7 said diaphragm having a spring forming portion, wherein the [membrane] diaphragm is made of at least two different materials, and wherein the flexible lip is made of a material that is softer than [the] said spring-forming portion [of the membrane].

38. A receptacle fitted with a pump as defined in claim 31.

39. A pump according to claim 2, wherein the thin zone is formed by reducing the thickness of the diaphragm by at least 25%.

40. A pump according to claim 18, wherein said annular portion, prior to the diaphragm being assembled in the pump, is at least twice as wide as it is thick.

41. A pump according to claim 1, said sleeve having an initial length prior to assembly in the pump wherein, when the moving member is at rest, the length of the [central portion of the diaphragm] sleeve after being assembled in the pump is greater than or equal to twice [its] said initial length [prior to assembly in the pump].

42. A pump according to claim 1, said sleeve having an initial length prior to assembly in the pump wherein, when the moving member is at rest, the length of the [central portion of the diaphragm] sleeve after being assembled in the pump is greater than or equal to 3 times [its] said initial length [prior to assembly in the pump].

43. A pump according to claim 1, said sleeve having an initial length prior to assembly in the pump wherein, when the moving member is fully depressed, the length of the [central portion of the diaphragm] sleeve is greater than or equal to 3 times [the] said initial length [of the diaphragm prior to assembly in the pump].

44. A pump according to claim 1, said sleeve having an initial length prior to assembly in the pump wherein, when

13

the moving member is fully depressed, the length of the [central portion of the diaphragm] *sleeve* is greater than or equal to 4 times [the] *said* initial length [of the diaphragm prior to assembly in the pump].

45. A pump according to claim 27, wherein said portions 5
in relief are made on the diaphragm and are constituted by

14

bulges uniformly distributed around the axis of the [central portion of the diaphragm] *sleeve* at its opening, said bulges extending over the top face of the diaphragm.

* * * * *