

US00RE40101E

(19) **United States**
(12) **Reissued Patent**
Krichever et al.

(10) **Patent Number:** **US RE40,101 E**
(45) **Date of Reissued Patent:** **Feb. 26, 2008**

(54) **ELECTRO-OPTICAL SCANNER HAVING
SELECTABLE SCAN PATTERN**

3,957,339 A	5/1976	Engel	350/6
3,972,599 A	8/1976	Engel et al.	350/294
4,015,120 A	3/1977	Cole	250/216
4,054,361 A	10/1977	Noguchi	350/7
4,129,355 A	12/1978	Noguchi	350/6.7
4,203,652 A	5/1980	Hanada	350/182

(75) Inventors: **Mark Krichever**, Hauppauge, NY (US); **Joseph Campanelli**, Hauppauge, NY (US); **Lisa Courtney**, Centereach, NY (US); **Peter Fazekas**, Baypoint, NY (US); **Joel Kahn**, Rockville Centre, NY (US); **Jerome Swartz**, Old Field, NY (US); **Vladimir Gurevich**, Stony Brook, NY (US); **Boris Metlitsky**, Stony Brook, NY (US)

(Continued)

FOREIGN PATENT DOCUMENTS

DE	3602008	1/1986
EP	0230892	1/1987
EP	0304804	8/1988
EP	0752680	6/2002

(73) Assignee: **Symbol Technologies, Inc.**, Holtsville, NY (US)

OTHER PUBLICATIONS

(21) Appl. No.: **11/396,226**

MS900 Service Manual, Metrologic Instruments, Inc., Sep. 1992, MITC 029291– MITC 029324.

(22) Filed: **Mar. 30, 2006**

MS900 Series, Jan. 2000, MITC 029936– MITC 029937.

Related U.S. Patent Documents

Reissue of:

(64) Patent No.: **5,988,502**
 Issued: **Nov. 23, 1999**
 Appl. No.: **09/009,231**
 Filed: **Jan. 20, 1998**

Metrologic, MS900, No date on documents, MITC 069153– MITC 069154.

MS941 and MS961, Jun. 1998, MITC 069115– MITC 069156.

MS900 Product Specifications, Metrologic, No date on documents, MITC 069141– MITC 069152.

MS900 Hand–Held Single Scan Line Scanner, Revised Aug. 1998, MITC 069125– MITC 069131.

U.S. Applications:

(63) Continuation-in-part of application No. 08/912,147, filed on Aug. 15, 1997, now Pat. No. 5,859,417, which is a continuation of application No. 08/405,585, filed on Mar. 17, 1995, now abandoned, which is a continuation-in-part of application No. 08/268,982, filed on Jun. 30, 1994, now Pat. No. 5,742,038.

MS900, Deposition Exhibit Knowles 8, Jun. 1990, MITC 068282– MITC 068287.

Primary Examiner—Karl D. Frech

(74) *Attorney, Agent, or Firm*—Allen, Dyer, Doppelt, Milbrath & Gilchrist, P.A.

(51) **Int. Cl.**
G06K 7/10 (2006.01)

(57) **ABSTRACT**

(52) **U.S. Cl.** **235/454**; 235/462.22; 359/204

A wavelength selector in an optical scanner is operative for selecting a first laser beam having a predetermined wavelength to produce a first scan pattern, and for selecting a second laser beam having a different wavelength to produce a second scan pattern. The scan patterns have a different number of scan lines. The selected scan pattern is scanned over indicia, e.g., a bar code symbol, to be read.

(58) **Field of Classification Search** 235/454, 235/462.22, 462.39, 455; 359/204

See application file for complete search history.

(56) **References Cited**

U.S. PATENT DOCUMENTS

4,281,889 A 4/1973 Noguchi 350/6.8

24 Claims, 13 Drawing Sheets

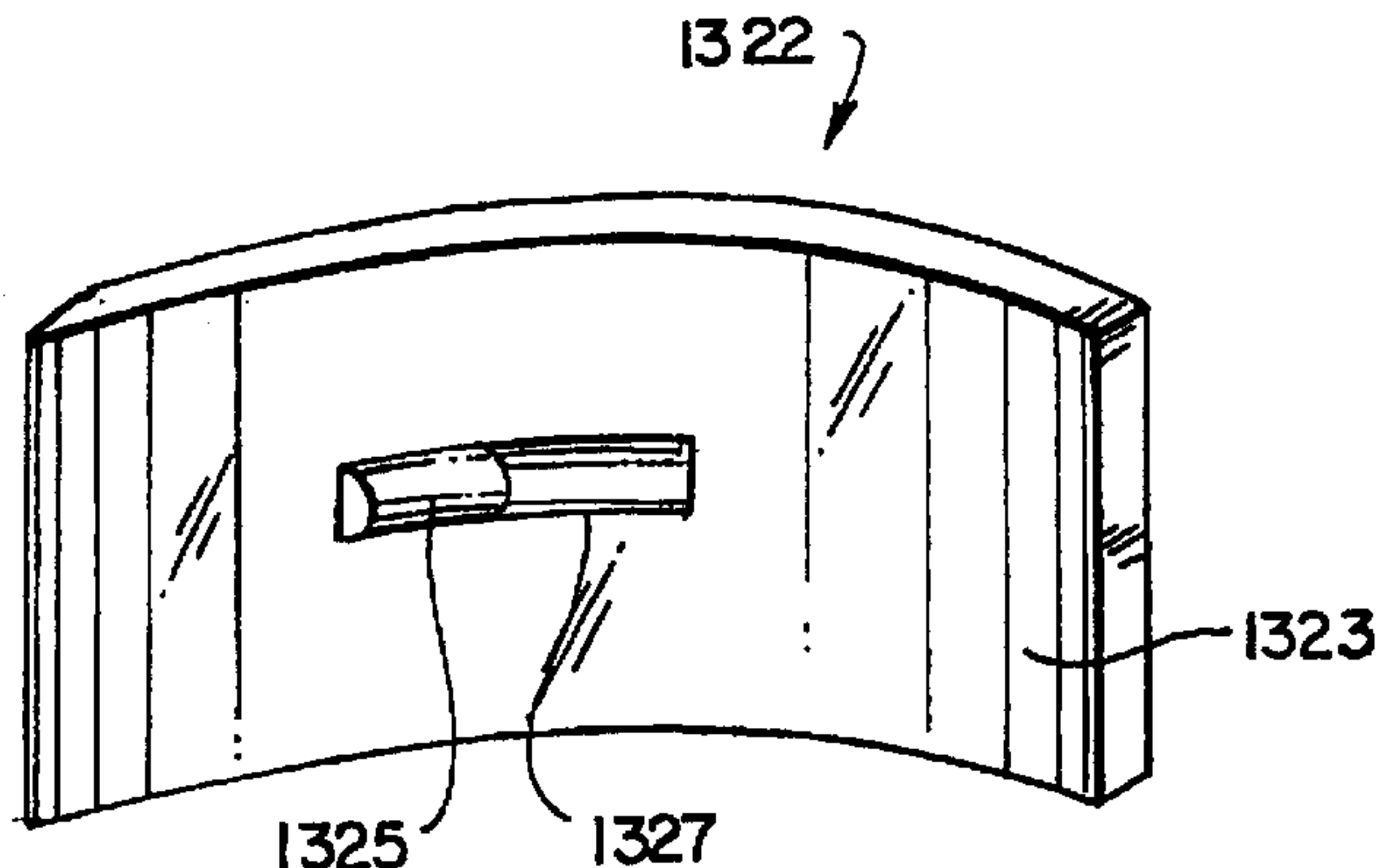
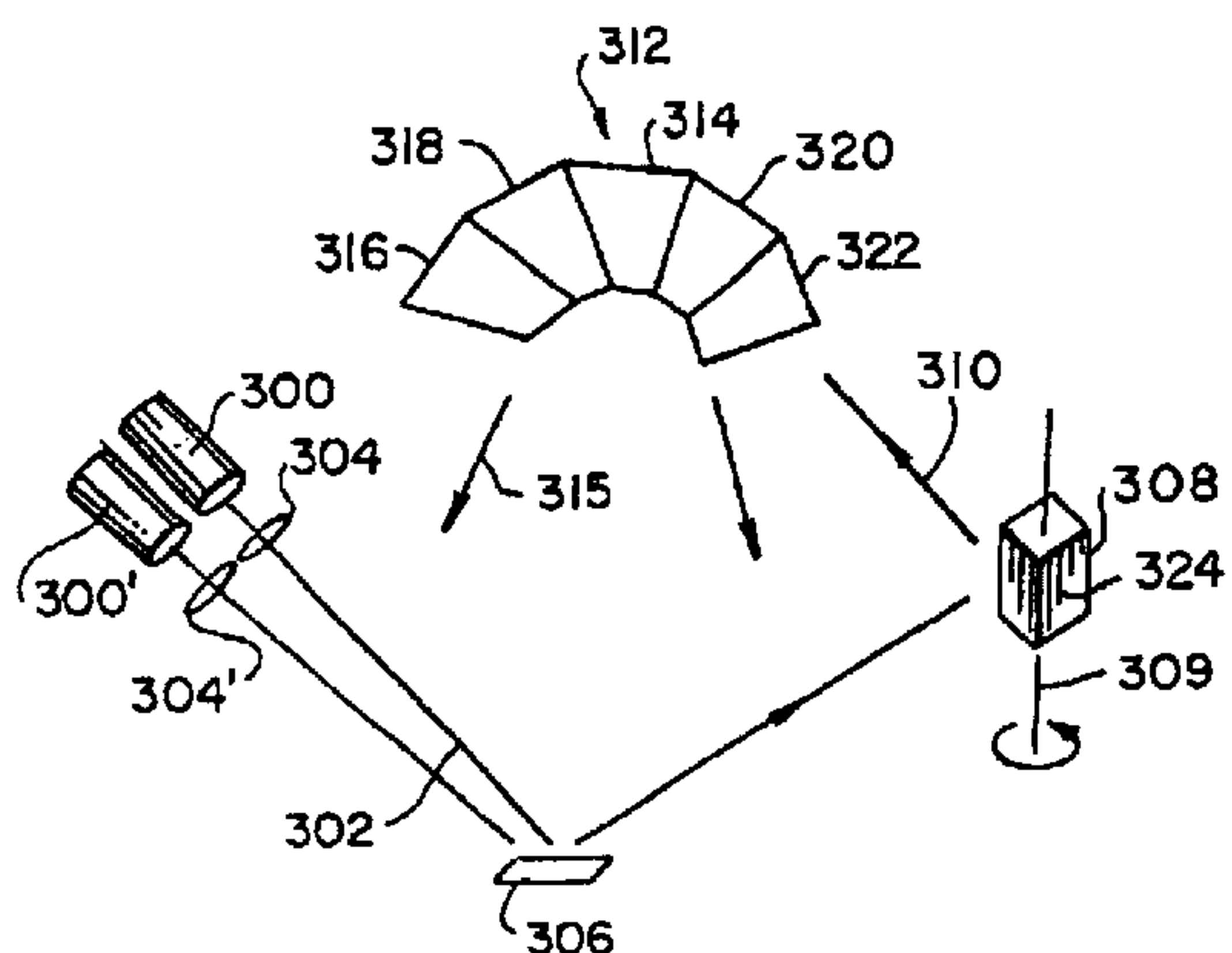

US RE40,101 E

Page 2

U.S. PATENT DOCUMENTS

5,260,553	A	11/1993	Rockstein et al.	235/462	5,736,721	A	*	4/1998	Swartz	235/383	
5,340,971	A	8/1994	Rockstein et al.	235/472	5,756,982	A	*	5/1998	Knowles et al.	235/472	
5,340,973	A	8/1994	Knowles et al.	235/472	5,804,805	A	*	9/1998	Koenck et al.	235/469	
5,420,411	A	*	5/1995	Salatto, Jr. et al.	235/472	5,859,417	A	*	1/1999	Dvorkis et al.	235/467
5,468,951	A	11/1995	Knowles et al.	235/472	4,294,506	A		10/1981	Hattori	350/6.8	
5,484,992	A	1/1996	Wilz et al.	235/472	4,967,074	A		10/1990	von Stein	250/236	
5,525,789	A	6/1996	Rockstein et al.	235/472	4,969,699	A		11/1990	Noguchi et al.	350/6.6	
5,528,024	A	6/1996	Rockstein et al.	235/472	5,064,258	A		11/1991	Inokuchi et al.	350/3.71	
5,591,953	A	1/1997	Rockstein et al.	235/462	5,081,639	A		1/1992	Snyder et al.	372/101	
5,600,119	A	*	2/1997	Dvorkis et al.	235/462	5,115,334	A		5/1992	Tomita	359/216
5,609,223	A	*	3/1997	Iizaka et al.	186/61	5,235,167	A	*	8/1993	Dvorkis et al.	235/462

* cited by examiner

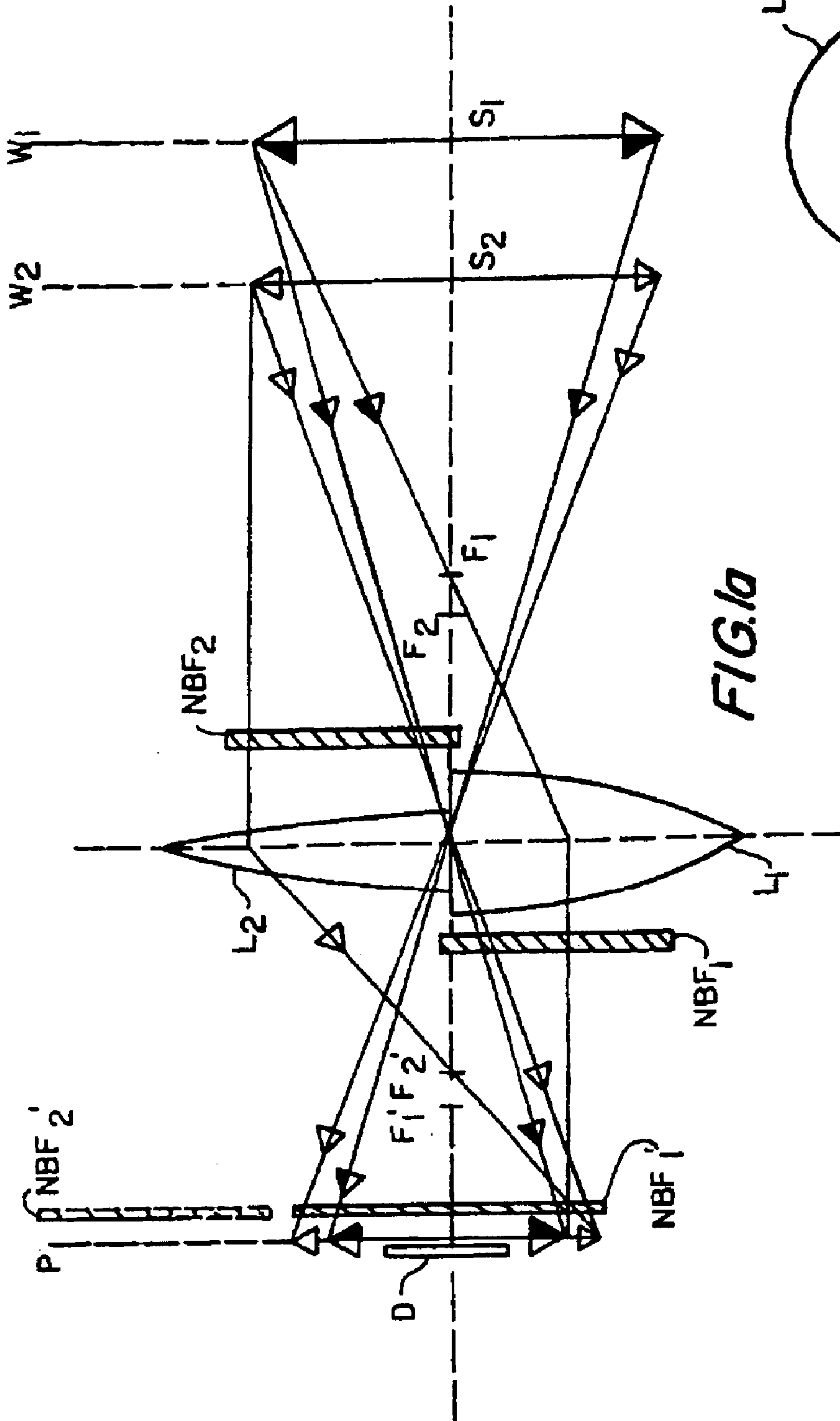

FIG. 1a

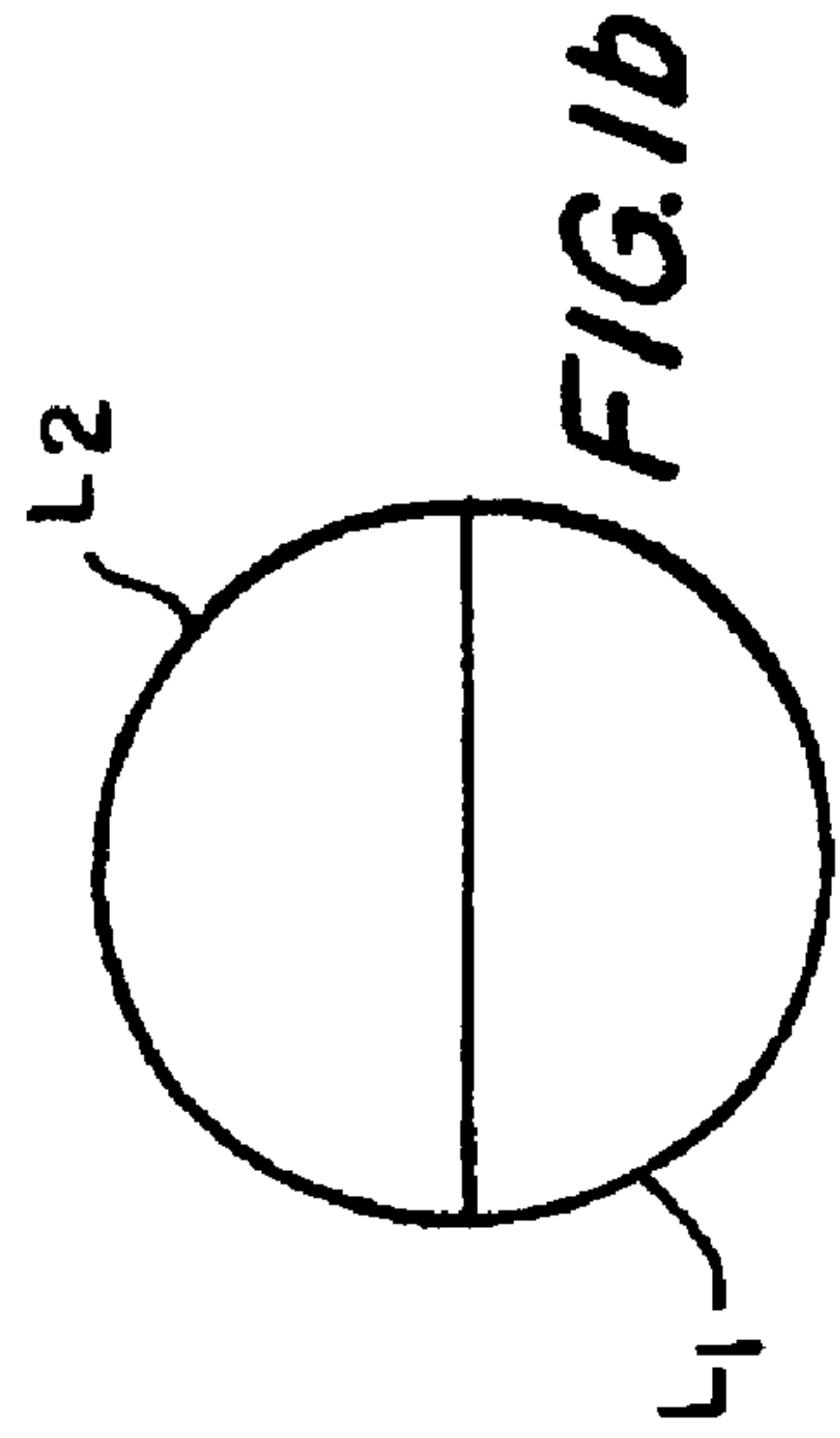

FIG. 1b

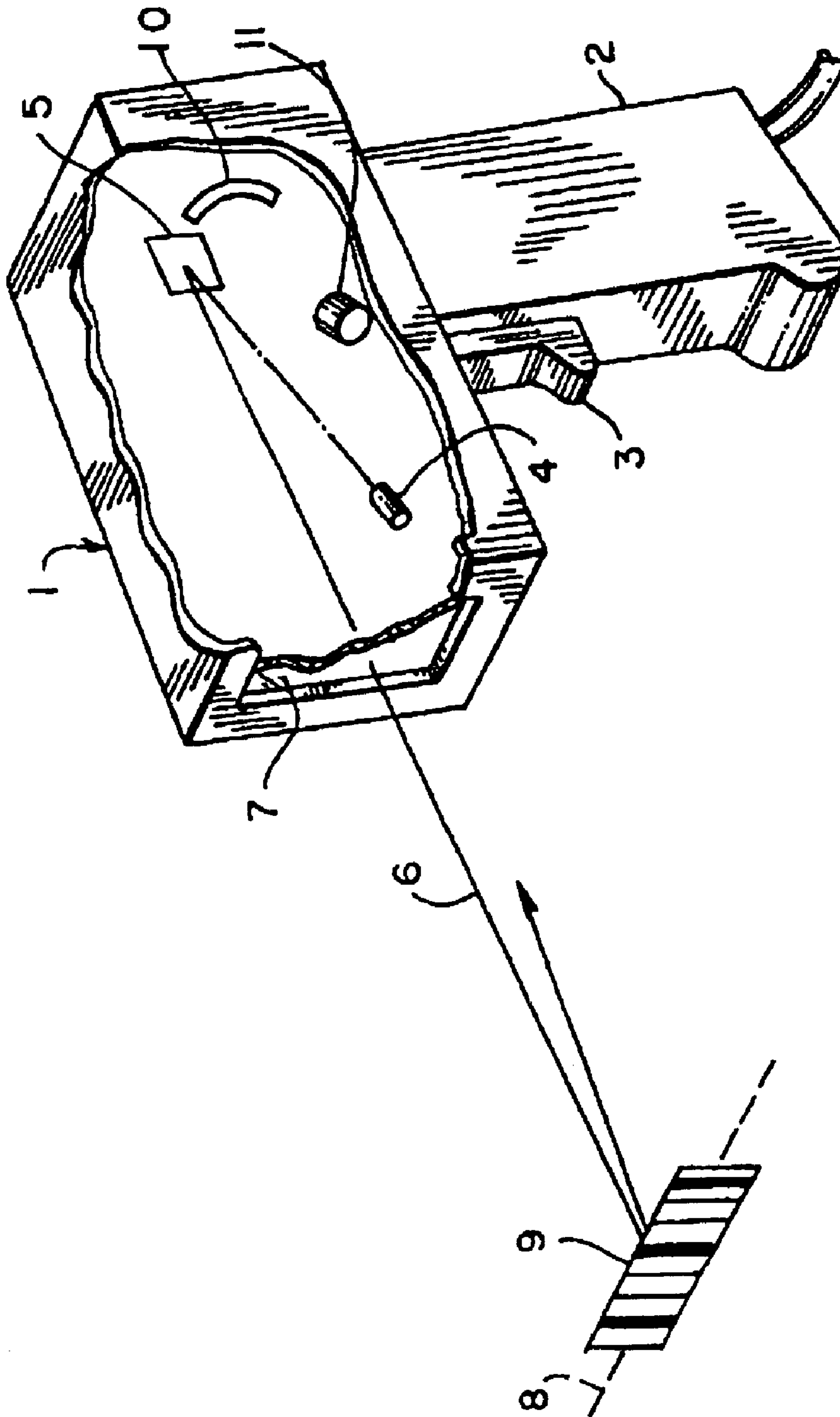
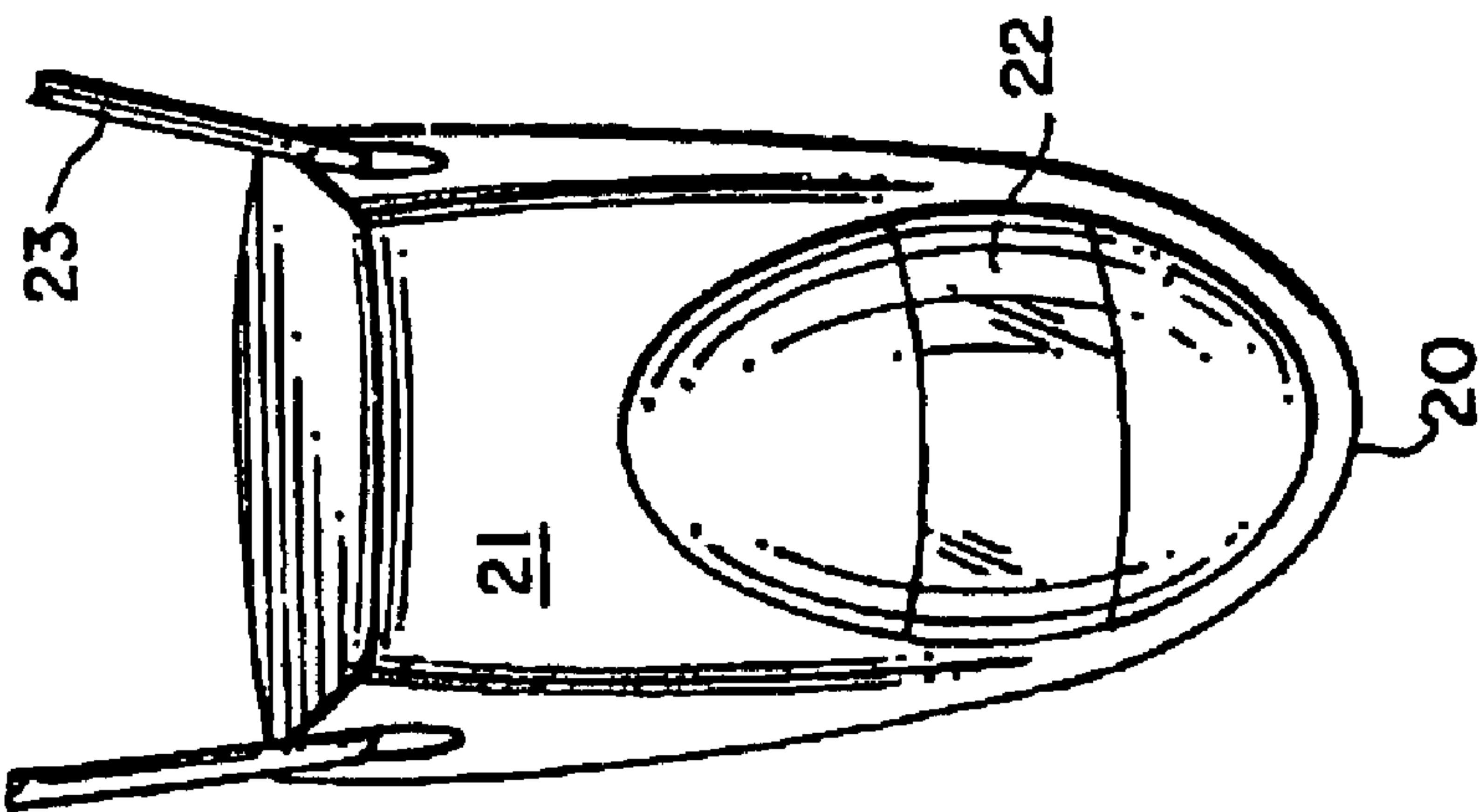
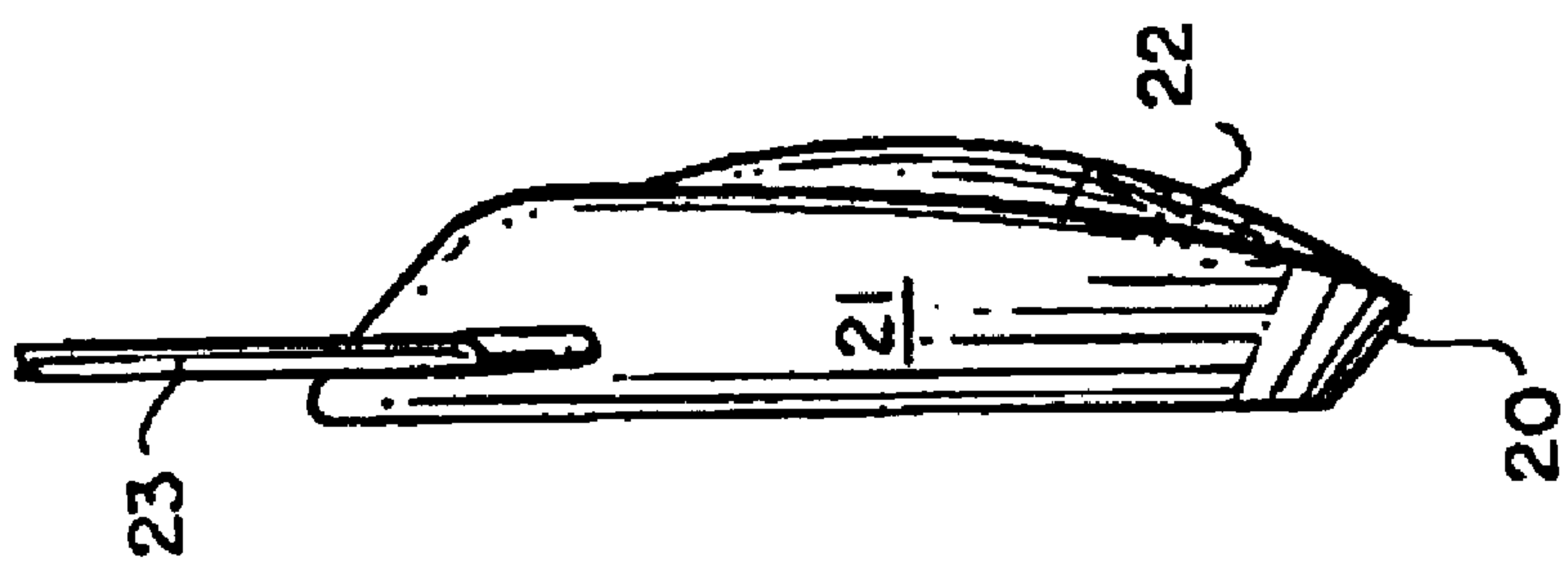
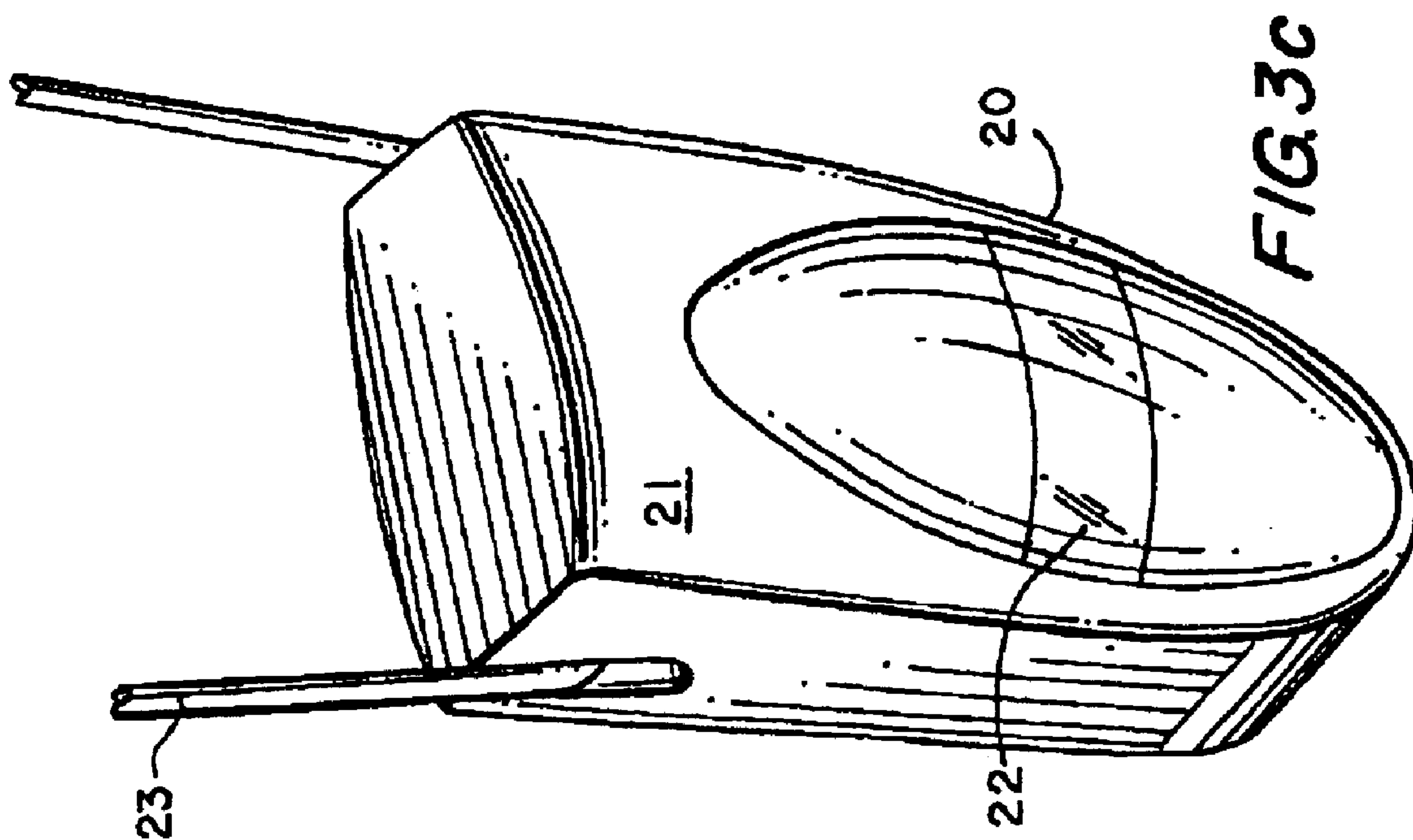

FIG. 2



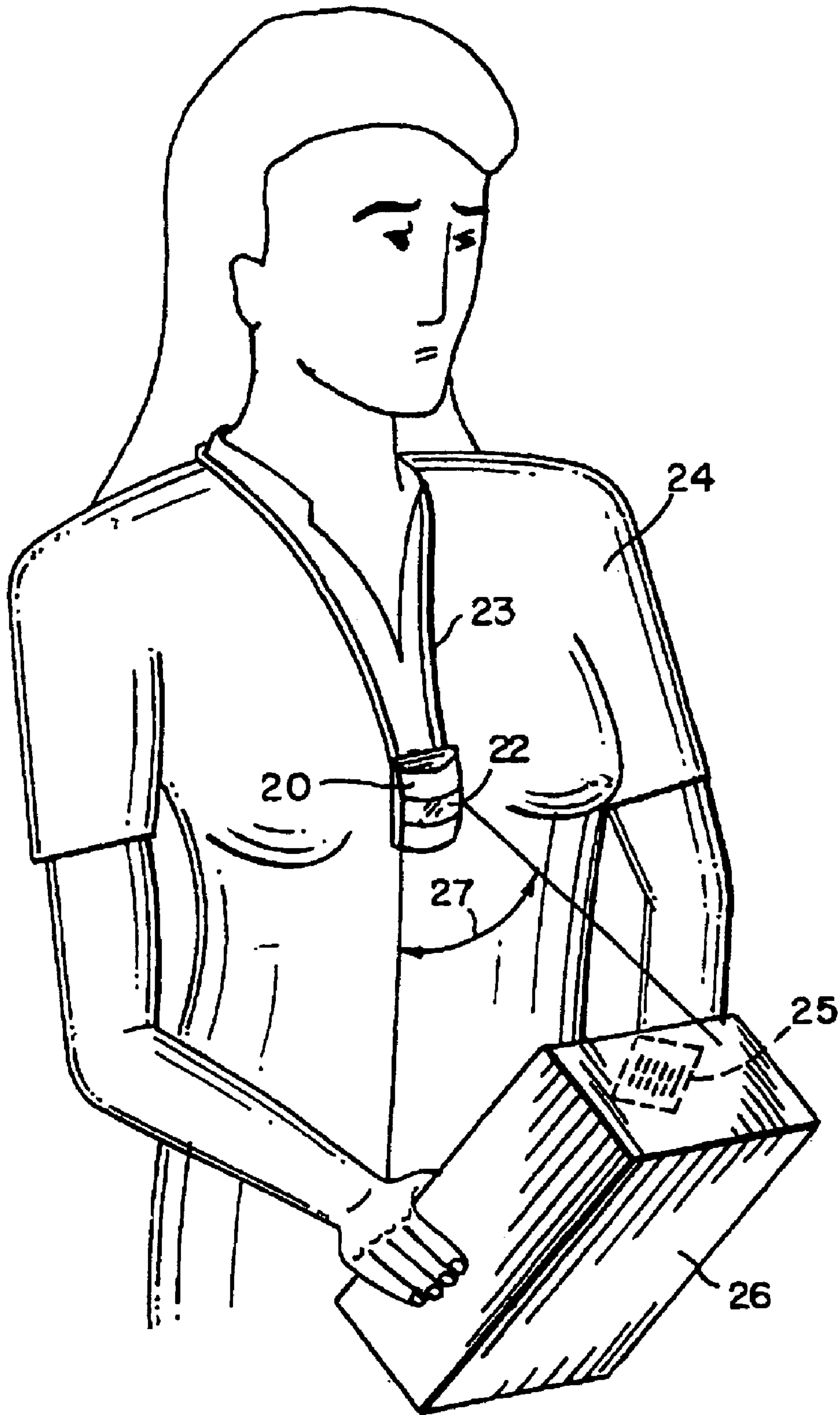

FIG. 3d

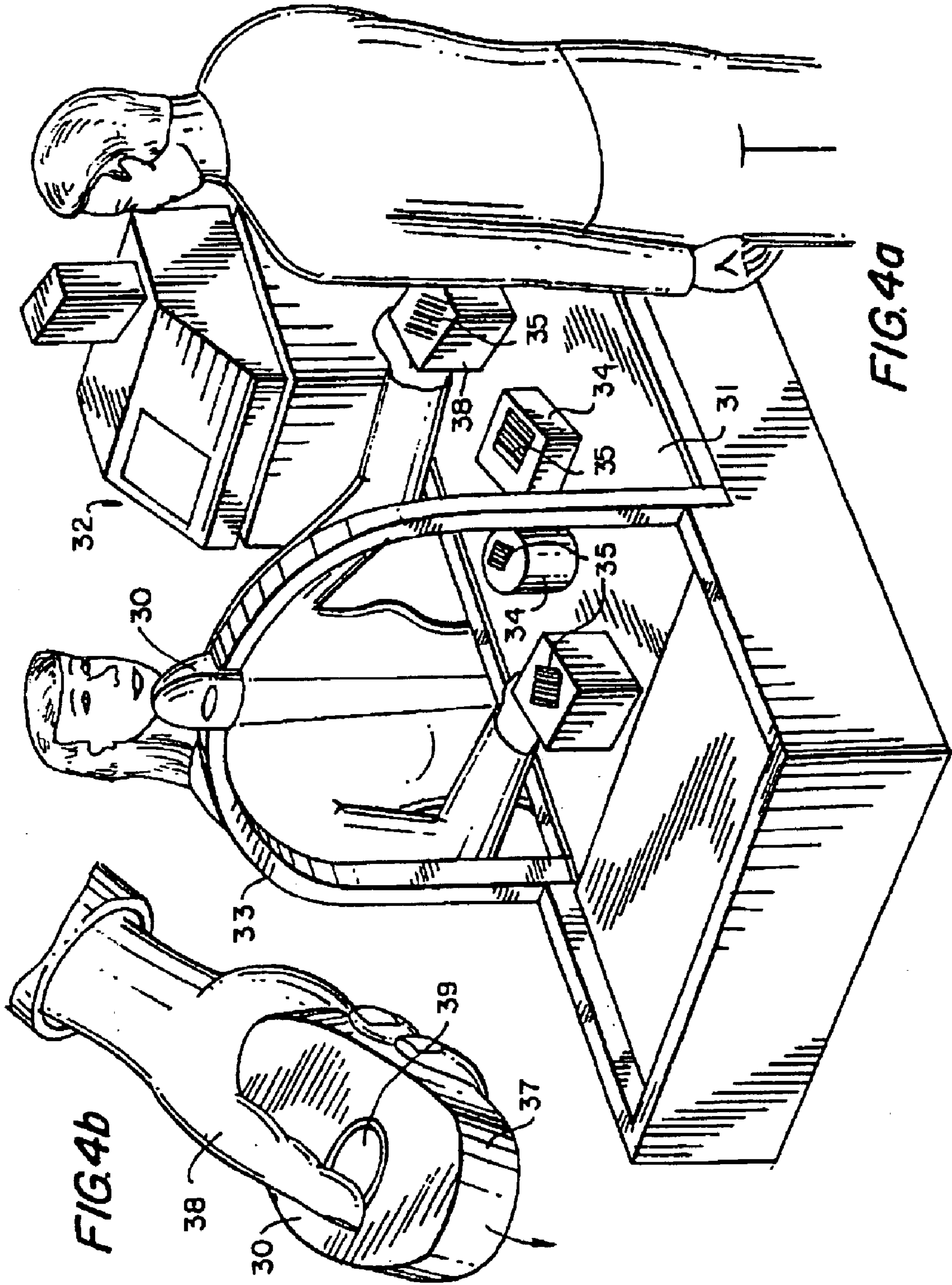

FIG. 4b

FIG. 40

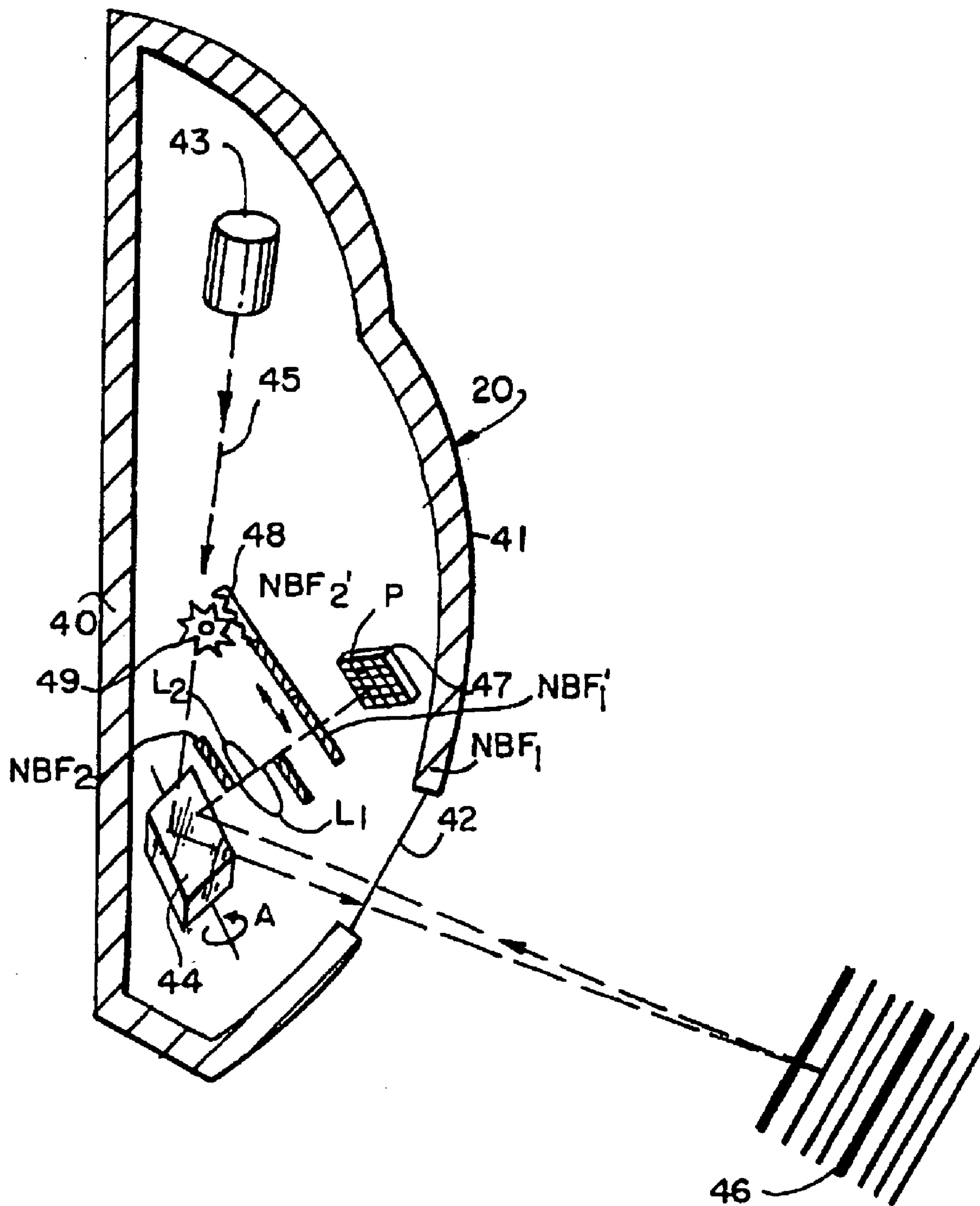

FIG. 5

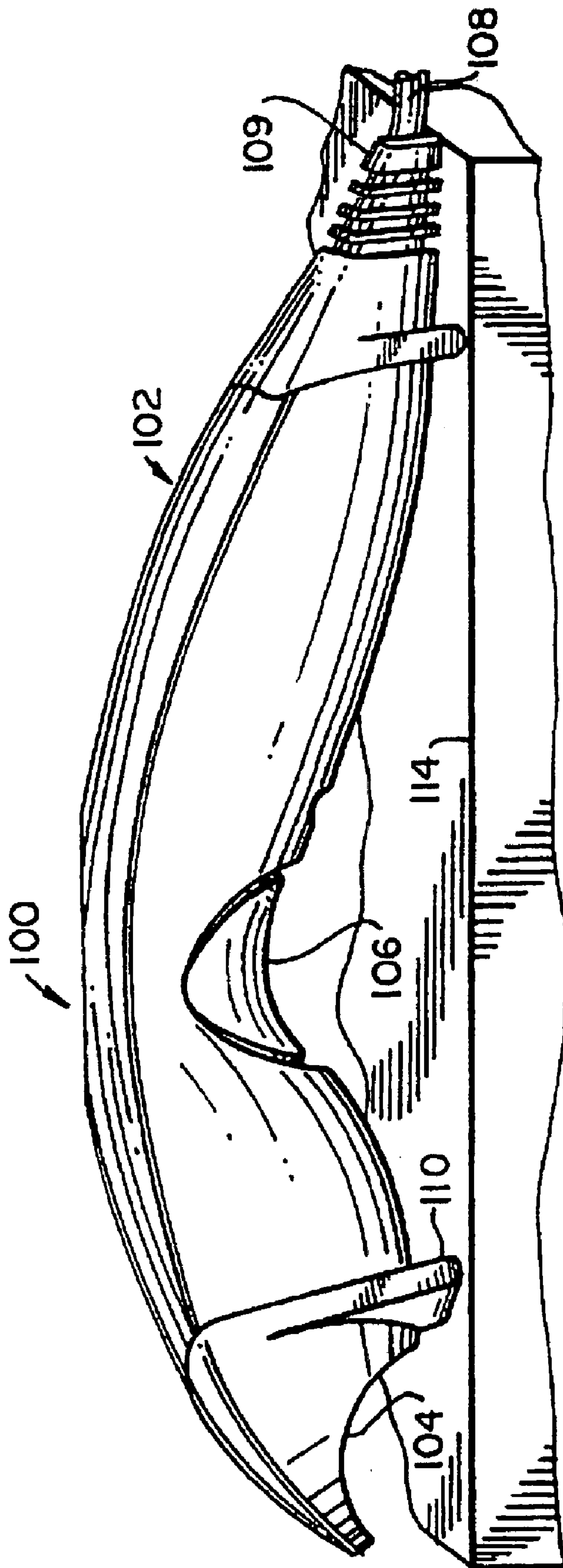
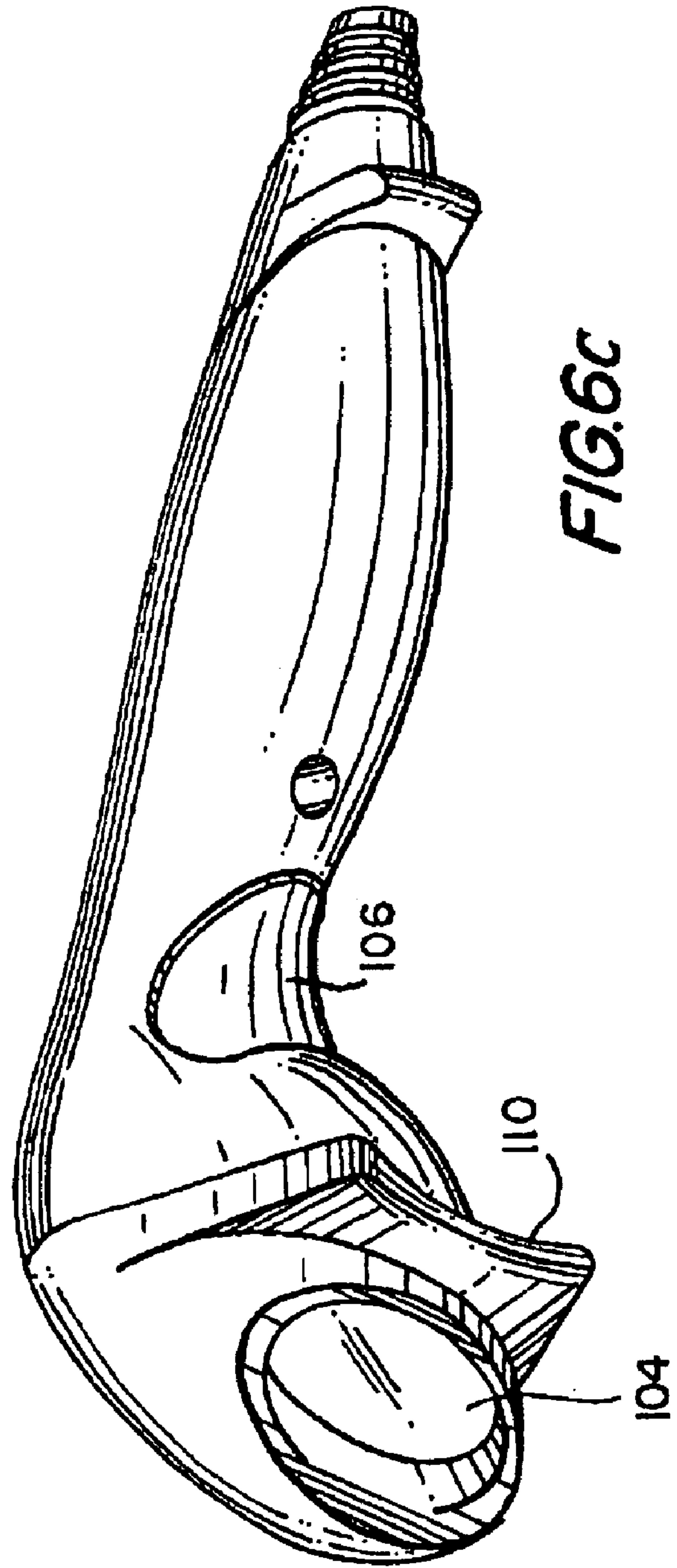
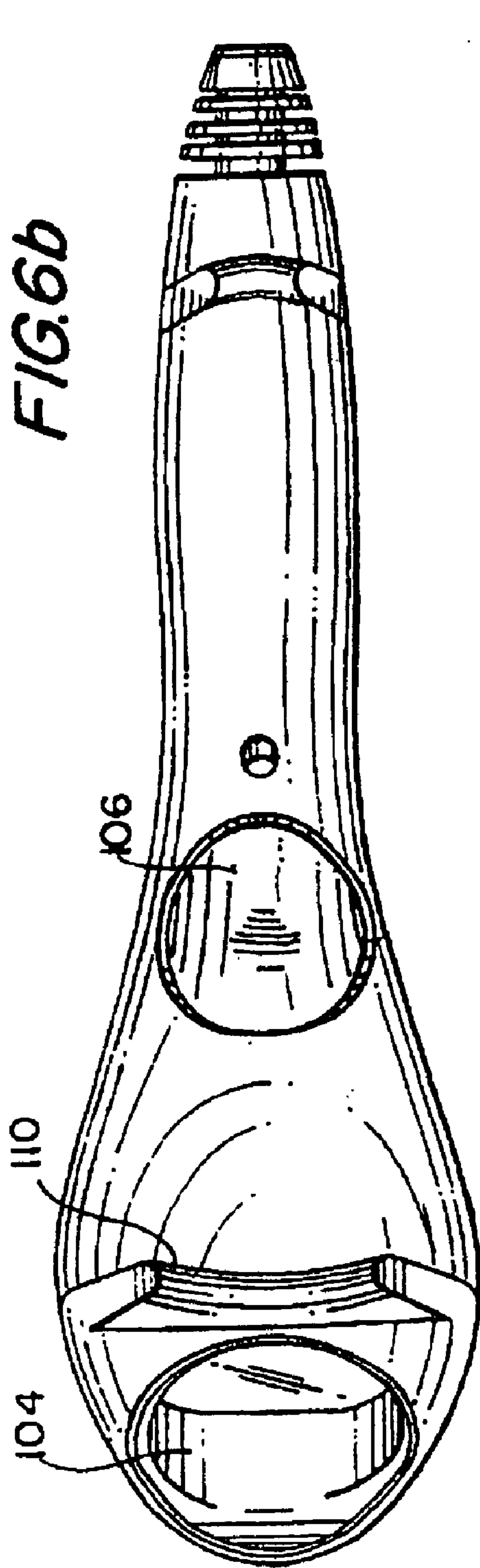

FIG. 6a



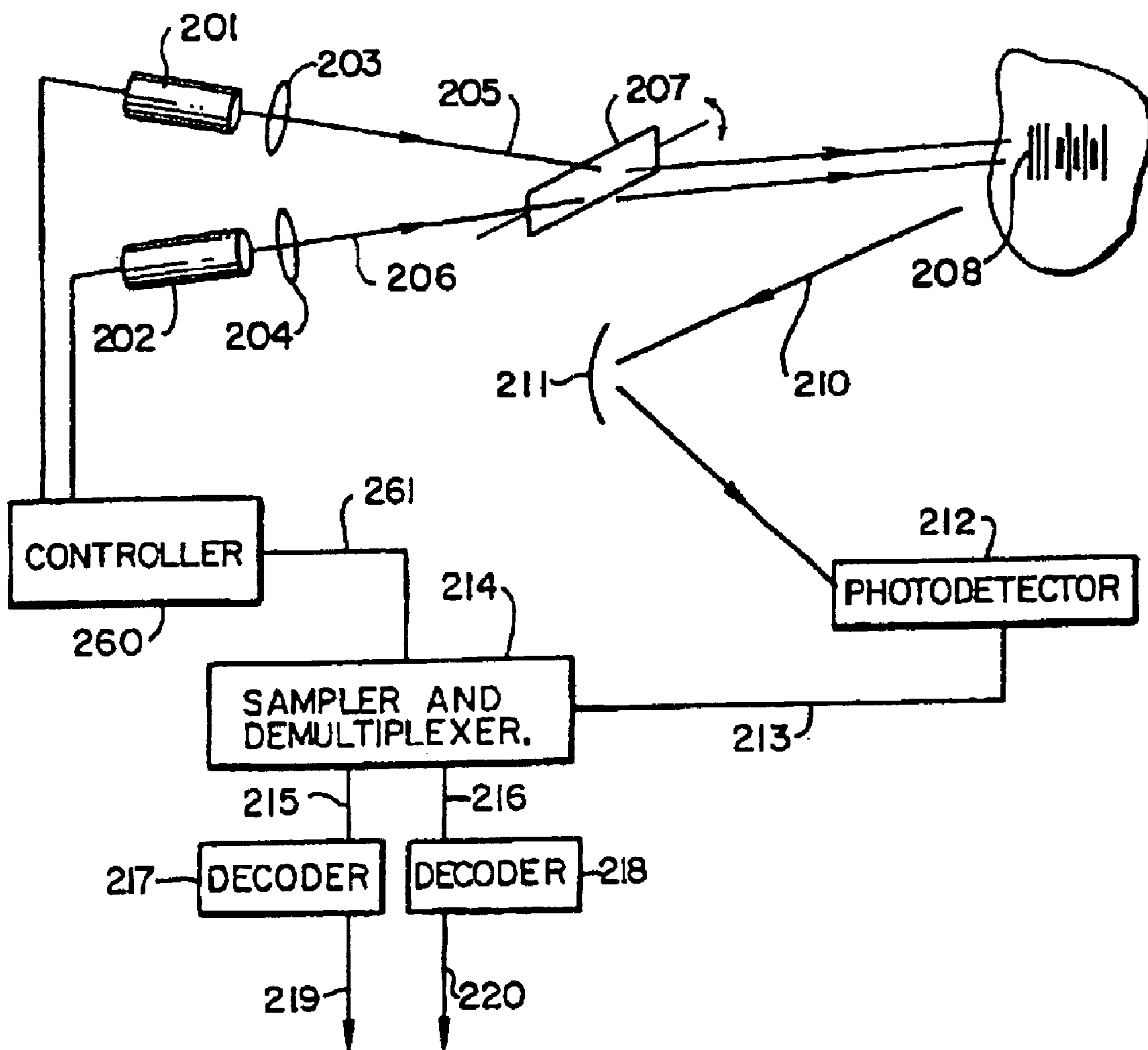

FIG. 7

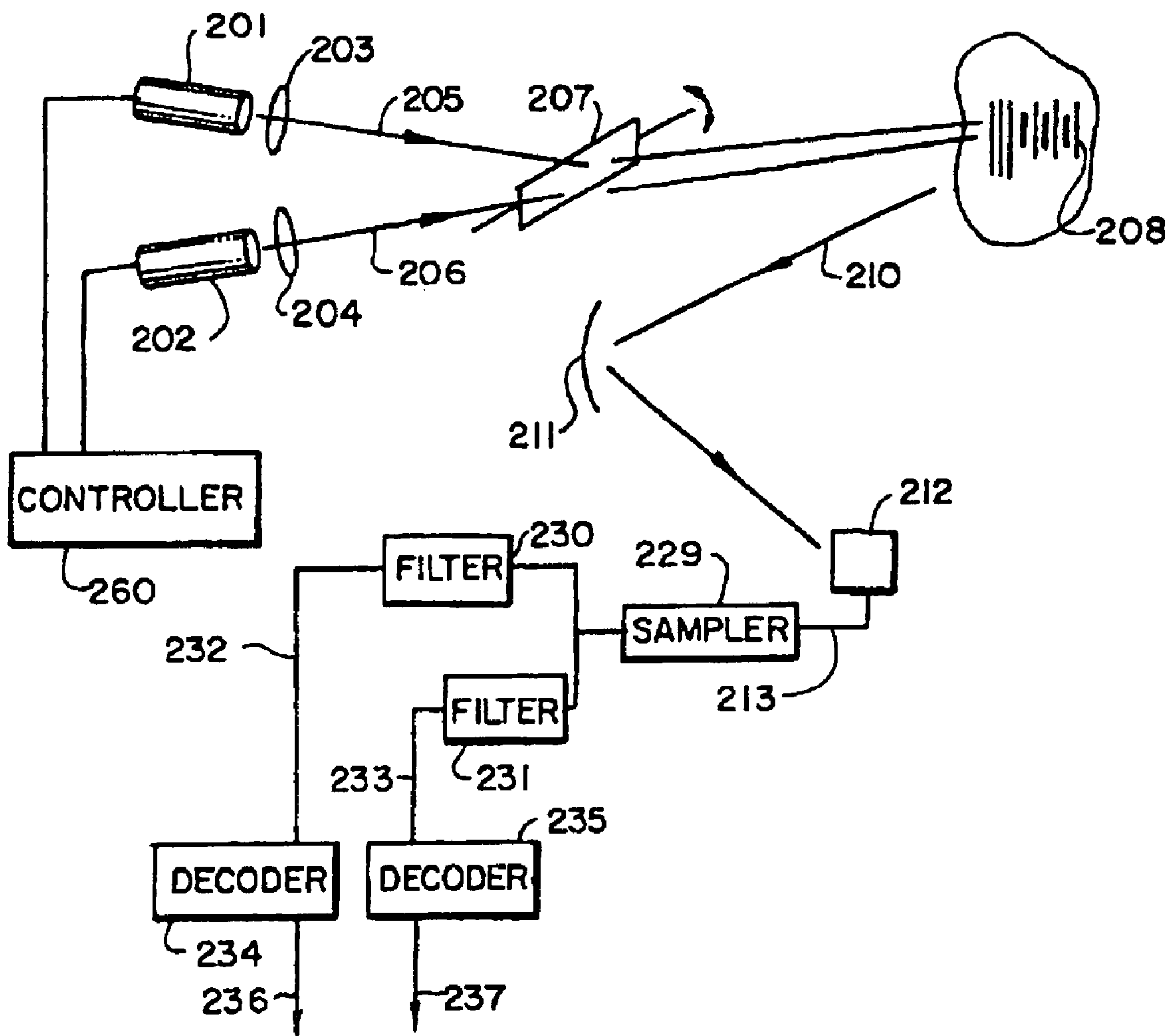
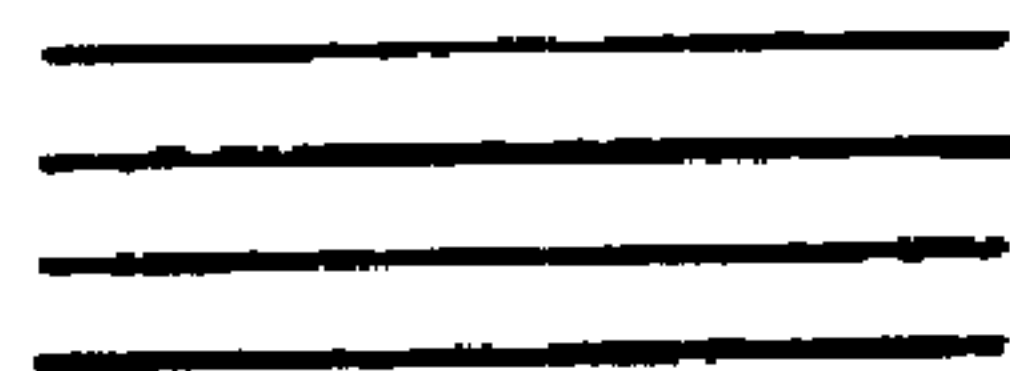
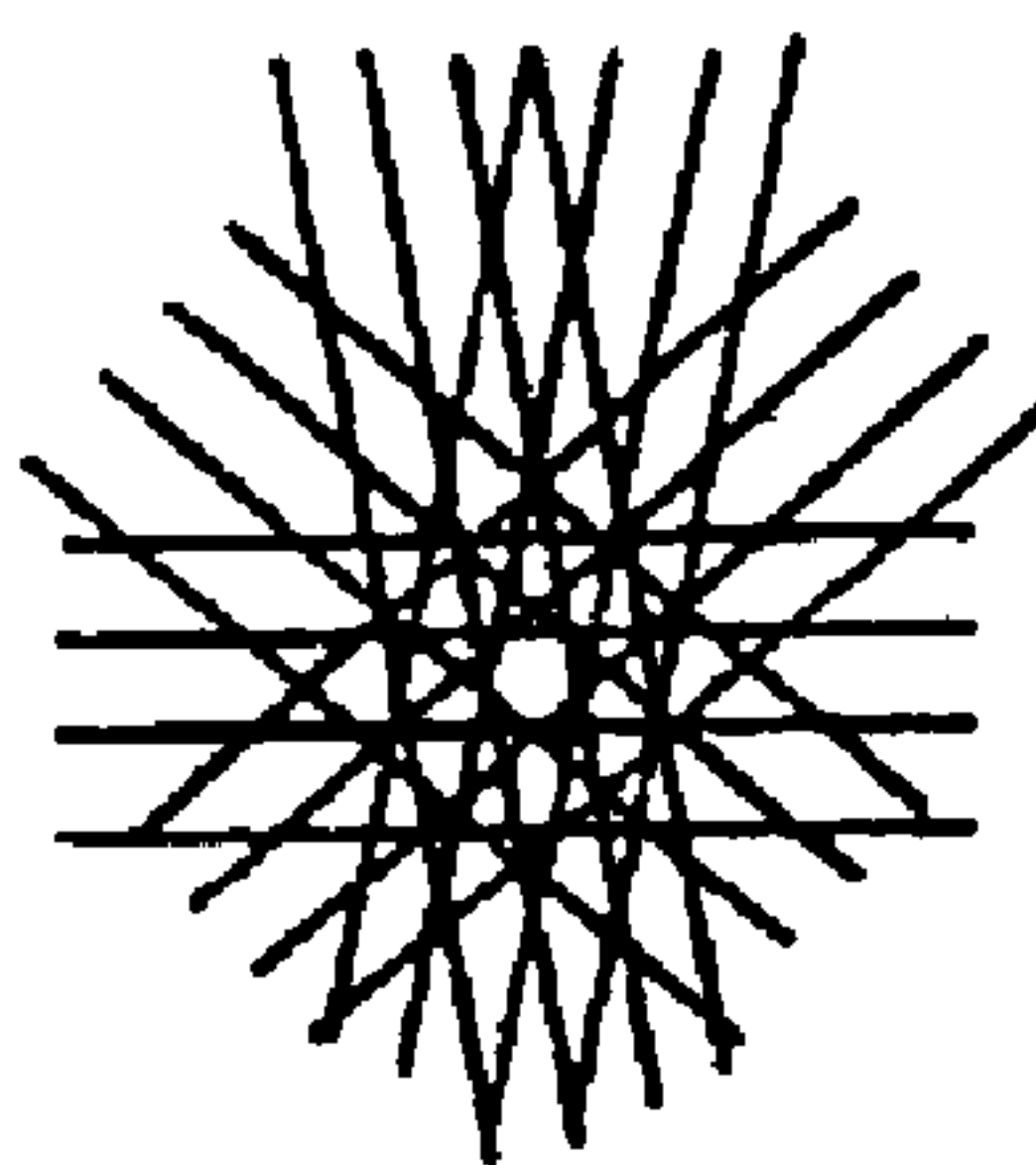
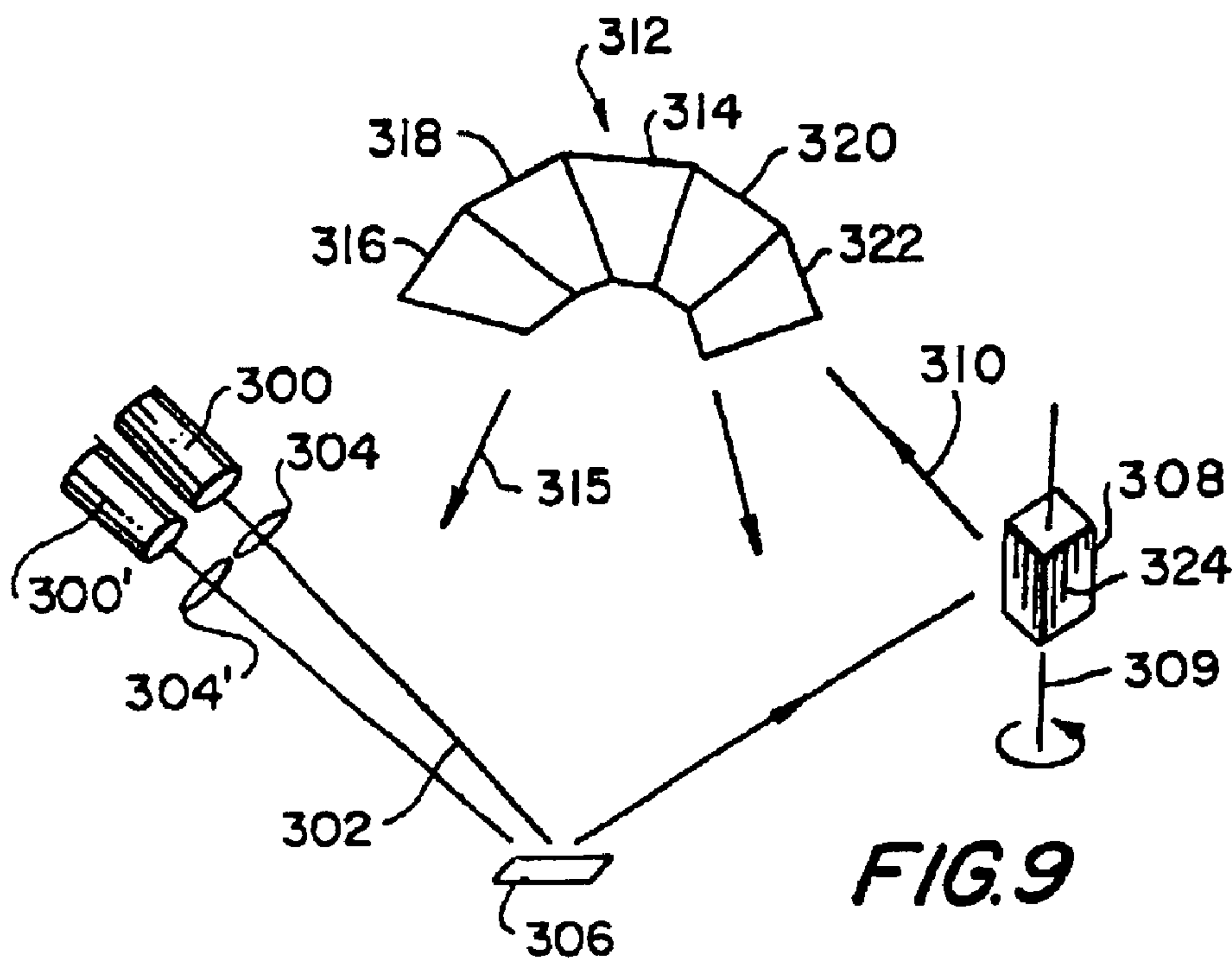

FIG. 8



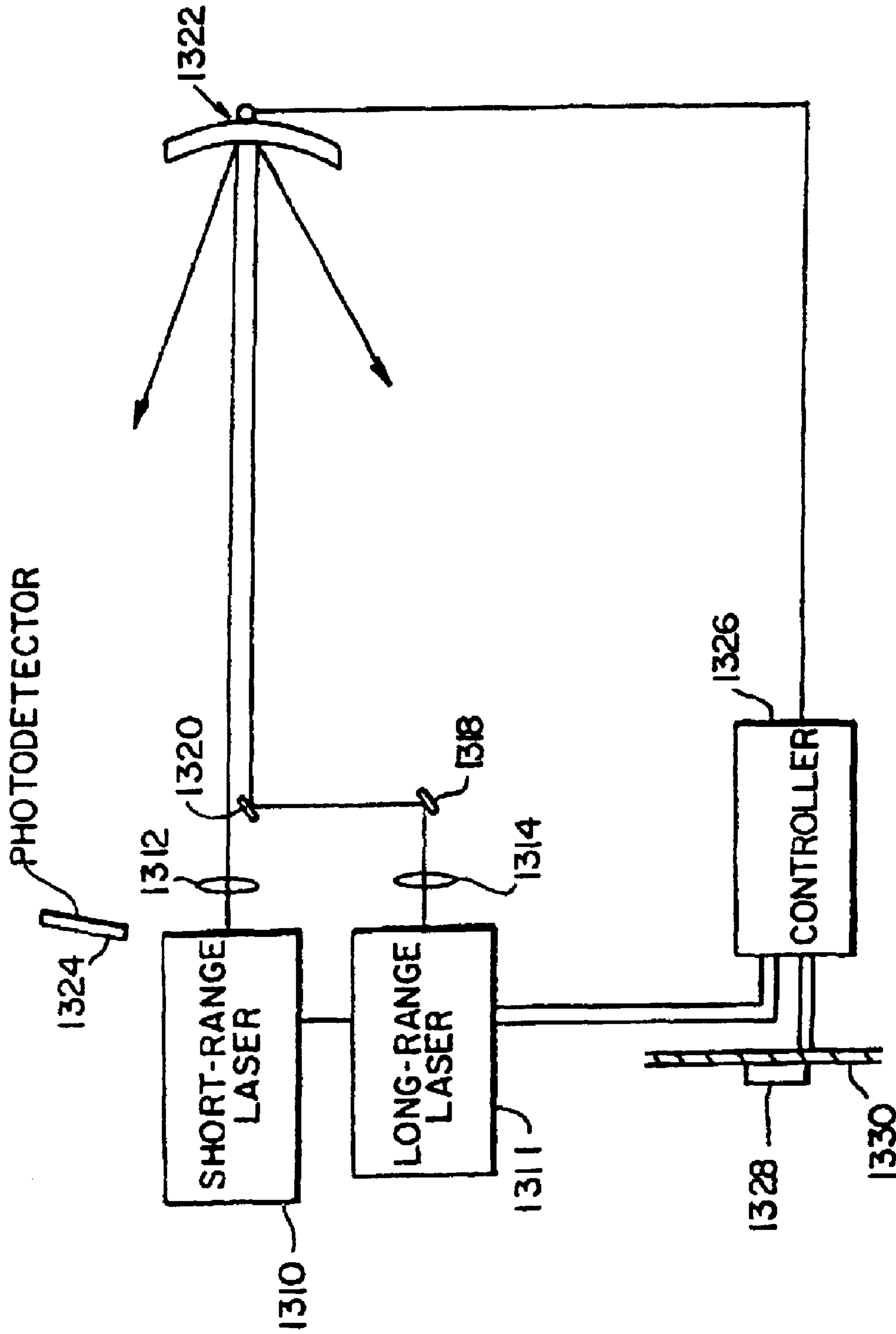

FIG. 11

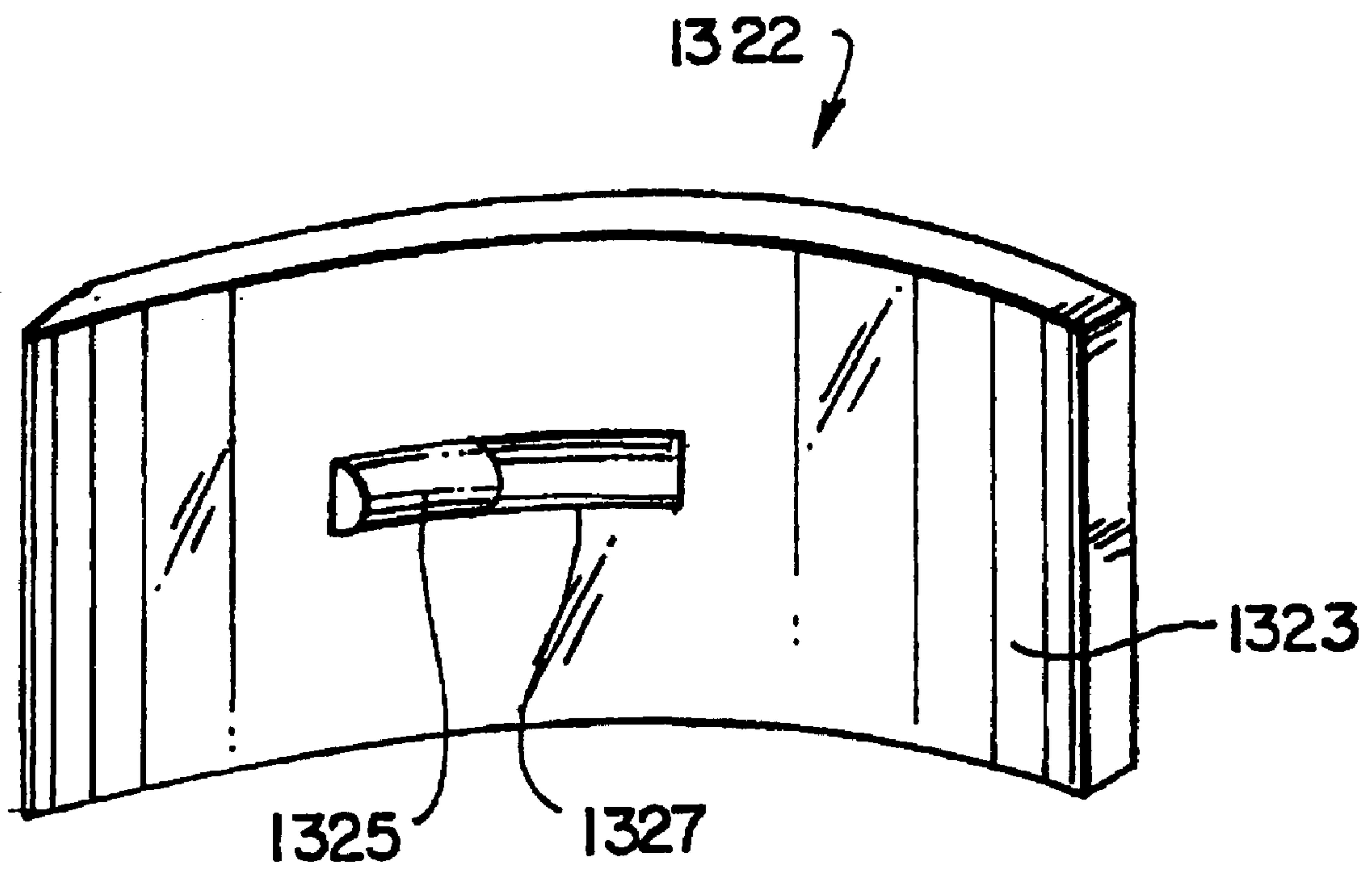

FIG. 12

ELECTRO-OPTICAL SCANNER HAVING SELECTABLE SCAN PATTERN

Matter enclosed in heavy brackets [] appears in the original patent but forms no part of this reissue specification; matter printed in italics indicates the additions made by reissue.

REFERENCES TO RELATED APPLICATION

This application is a continuation-in-part of U.S. patent application *Ser. No. 08/912,147 filed Aug. 15, 1997, now U.S. Pat. No. 5,859,417 which is a continuation of Ser. No. 08/405,585 filed Mar. 17, 1995, abandoned, and is related to U.S. Ser. No. 08/864,452, filed May 28, 1997, now allowed.*

BACKGROUND OF THE INVENTION

FIELD OF THE INVENTION

The invention relates generally to optical scanners, and in particular to scanners having dual or multiple working ranges.

Most optical scanners such as bar code scanners are adapted for use at a particular distance, or a range of distances, from an indicia to be scanned. If the user holds the scanner too close to the indicia, or too far away, the indicia and/or the flying spot beam will not be in focus, and decoding will not be possible.

Such scanners may not be particularly convenient in environments where a series of indicia to be read are presented to the scanner at various distances, and where it is difficult or impossible for the user to alter the distance between the scanner and the indicia. To deal with such situations, attempts have been made to expand the acceptable working range of conventional scanners, to give the user as much leeway as possible, and also to provide multi-distance scanners which can operate, for example, at a first working range or at a second working range according to the user's preference or requirements. One possibility is for the provision of a two-position switch on the scanner, with the scanner operating at a first working distance in a first position of the switch and at a second working distance in a second position. A disadvantage of such scanners is that they require additional moving parts to provide for operation at the two separate working ranges. Such systems are also not "automatic" in the sense that the user has manually to select the correct working range, according to the distance of the current indicia to be read; if the incorrect working range is chosen, a decode will not result.

One of the difficulties that bar code reader designers face when attempting to produce increased working ranges is that the greater the working range, and the greater the range of possible indicia that might be read, the lower tends to be the resultant signal to noise ratio in light that is reflected from the indicia. One approach for dealing with this involves the provision of non-conventional optics, in which the optics associated with either the laser or with the photodetector have two distinct focal points. An example of this is shown in U.S. Pat. No. 5,332,892, which is commonly assigned with the present application. In the device shown in that document, the two focal points are associated with corresponding circuitry to provide two separate channels of data derived from the scanned bar code. The two channels have differing resolutions. As the working angle and density vary, at least one of the resolutions is likely to be appropriate for sensing all or most of the bar coded data, regardless of the distance of the bar code with respect to the scanner and/or

the size or density of the code. The scanning beams of bar code readers are typically derived from laser diodes. Such diodes are robust and relatively inexpensive, but they do suffer from the disadvantage that the beam emerging from a laser diode is astigmatic. The astigmatic laser diode can be characterized as having two apparent light sources spaced apart from each other along the optical path. One of the light sources lies in a horizontal plane, appears to be coming from inside the laser diode chip, and has a low angular divergence. The other apparent light source lies in a vertical plane, appears to be coming from a facet of the chip, and has a high angular divergence. The two apparent light sources, which are spaced apart from each other by typically about 20 micrometers, from two beam waists in different planes and in different directions, as measured relative to the planar junction of the chip.

The resultant relatively complex beam profile may need selective shaping before it can efficiently be used in an optical scanner. Some methods of providing such beam shaping are described in our co-pending U.S. patent application Ser. No. 08/268,982, filed Jun. 30, 1994, the teachings of which are incorporated herein by reference.

A simpler option is simply to provide separate long and short range visible laser diodes, as is suggested in our earlier patent U.S. Pat. No. 5,420,411.

A further problem associated with known arrangements is that of distinguishing the respective images received corresponding to objects in each working range.

The present invention, in various other embodiments, further relates to optical scanning stations having a conveyor for moving articles carrying indicia to be read past an optical scanner, and to optical scanners having means for manually or automatically selecting one of a plurality of desired scan patterns.

The invention further relates, in yet further embodiments, to scanners having an extended working range using two lasers, each focused to cover a different portion of the scan distance. Present systems turn on one laser for a full scan, and then the second laser for the next scan, alternating on a scan-by-scan basis. Since, in general, only one of the lasers is capable of reading a bar pattern at any given distance, this technique typically doubles the length of time that it takes to generate a successful decode over single-laser embodiments. There is a need to regain the aggressiveness of a one-laser scanner, while maintaining the range benefits of the two-laser system. One device making use of two lasers is disclosed in our application Ser. No. 08/405,585, filed Mar. 17, 1995, now abandoned, the disclosure of which is incorporated herein by reference.

SUMMARY OF THE INVENTION

OBJECTS OF THE INVENTION

It is an object of the present invention at least to alleviate the problems of the prior art.

It is a further object to provide a multiple working range optical system, for example for a scanner arrangement capable of distinguishing between respective images corresponding to images in different working ranges.

It is yet a further object of the invention to provide a multiple working range optical scanner arrangement having a minimum of imaging and image-recording elements.

It is yet a further object of the invention to provide an optical scanner capable of being easily and conveniently mounted for optimum operation and user comfort.

It is yet a further object of the invention to provide a convenient and easily-operable optical scanning station, for example for use at a point of sale.

It is a further object to provide an optical scanner capable of generating different scan patterns using a single scanning mechanism.

It is yet a further object to provide an optical scanner which maintains the range benefits of a two-laser system, while providing the rapid decoding typical of a one-laser system.

FEATURES OF THE PRESENT INVENTION

According to the present invention there is provided a multi scan-pattern optical scanner including a laser assembly for producing a plurality of laser beams of differing wavelengths and a scanning mechanism including a wavelength selector for selectively passing a beam of predefined wavelength, thereby producing at least a first scan pattern from a beam which is passed by the selector and a second scan pattern from a beam which is stopped by the selector.

A device of this type allows for the creation of multiple scan patterns without the need to have individual scanning mechanisms for each pattern. In a preferred embodiment, parts of the scanning mechanism are coated or otherwise provided with filters to absorb, or to prevent the reflection of, at least one of the beams. Alternatively, parts of the mechanism may be coated so that only those coated parts reflect one of the beams. Preferably, the coatings may be thin coatings which achieve their reflective/absorptive effect by optical interference.

It would also be possible to provide holographic optical elements and/or diffraction gratings to separate two laser beams of differing wavelengths, and thereby allow them to be deflected differently by a single scanning mechanism.

Preferably, each laser is provided with its own optical assembly, providing individual focusing and allowing each laser to scan efficiently at a given working distance. To extend the overall working range even further, more than two lasers could be used, each having its own working distance.

The invention extends to any individual feature described above or set out in the specific description, and to any compatible combination of features. It is to be understood, in particular, that features shown in relation to one figure may be combined, where compatible, with features shown in connection with any other figure.

BRIEF DESCRIPTION OF THE DRAWINGS

The invention may be carried into practice in a number of ways and several specific embodiments will now be described, by way of example, with reference to the accompanying drawings, in which:

FIG. 1a shows a multiple range optical system according to an embodiment of the present invention;

FIG. 1b is an end view of the multi-focus lens used in the arrangement of FIG. 2a;

FIG. 2 shows a typical bar code scanner in conjunction with which the present invention may be implemented;

FIGS. 3a-3c shows a mounting option for an optical scanner;

FIG. 3d shows a user carrying the optical scanner in the mounting option of FIG. 3a;

FIG. 4a shows an alternative mounting option for an optical scanner;

FIG. 4b shows the optical scanner of FIG. 4a being used in dismounted mode;

FIG. 5 shows the internal arrangement of the scanner of FIG. 3a incorporating the multiple range optical system of FIG. 1; and

FIGS. 6a-6c shows an exemplary housing for a bar code scanner for use with any of the embodiment of the present invention;

FIG. 7 schematically illustrates an embodiment of a scanner having two pulse-mode operated lasers;

FIG. 8 shows a variation on the embodiment of FIG. 7;

FIG. 9 illustrates the use of filtered optics to implement multi-scan pattern generation; and

FIGS. 10a to 10c show scan patterns generated by the embodiment of FIG. 9;

FIG. 11 shows yet another embodiment, namely a dual-range scanner using dual laser beams; and

FIG. 12 shows in more detail a segmented scan mirror used in the embodiment of FIG. 11.

DETAILED DESCRIPTION OF THE PREFERRED EMBODIMENTS

Referring first to FIG. 1, there is shown a multiple working range optical system according to one embodiment of the present invention, forming effectively an imaging auto-focusing device. The arrangement comprises a lens system L_1, L_2 and a narrow band filter system NBF_1, NBF_2 . Although any number of lenses and filters can be included allowing, as will become clear from the following discussion, a corresponding number of working ranges, in the present embodiment for the purposes of simplicity a system including two lenses and associated filters is shown, providing two working ranges.

The lens system shown in FIGS. 1a and 1b comprises two semi-circular convex lens elements L_1, L_2 with respective focal lengths F_1, F_2 . Two working ranges W_1, W_2 are selected and the lens power of the respective lens element is selected such that the conjugate image planes corresponding to the object planes defined by working ranges W_1, W_2 coincide at plane P. Accordingly a first object S_1 at working range W_1 is focused onto plane P by lens element L_1 . Additionally a second object S_2 at working range W_2 is focused by lens element L_2 at plane P. Thus the system is able automatically to focus objects at different ranges. It will be understood that, in the case of a bar code reader, the objects S_1, S_2 would be bar code symbols to be read. Because the conjugate image planes coincide for the working ranges, only a single detector D is required; this could, for example, be a charge coupled device array, or conventional film. Furthermore complex beam propagation or mirror assemblies are not required. In order to increase the number of working ranges the lens system is simply enhanced by including further lens elements and associated filters arranged to image objects in additional working ranges onto the plane P. In such a case, each lens element would form a segment of a circular multi-focus lens.

Associated with each lens element L_1, L_2 is a respective spectral narrow band filter NBF_1, NBF_2 . The filters NBF_1, NBF_2 are arranged to pass different wavebands of light received from the objects S_1, S_2 . As a result the images of the objects S_1, S_2 at plane P are composed of light of different wavelengths and can be resolved from one another. In order to do this, the system is provided with additional movable, filters NBF_1', NBF_2' . Each filter can be moved into position in front of the detector D to allow light of the relevant

5

wavelength to pass dependent on which working range is selected. If the working range W_1 is selected, light from the object S_1 passes through the lens element L_1 , is filtered at NBF_1 , and then passes through the movable filter NBF_1' (now in position in front of the detector D); light which may have passed through NBF_2 and lens element L_2 is blocked at NBF_1' and so cannot form an image at D. If the working range W_2 is selected, NBF_2' is moved into position, and S_2 is imaged; light from S_1 passing through L_1 and NBF_1 is then blocked at NBF_2' .

FIG. 2 illustrates an exemplary hand-held laser scanner suitable for use with the embodiment of FIG. 1, or indeed suitable for use with any other compatible embodiments to be subsequently described.

The scanner of FIG. 2 comprises a main body 1 having a graspable hand portion 2 which carries a trigger 3. Within the body 1 is a laser module 4. Light from the laser module 4 is arranged to shine onto an oscillating mirror 5. The resulting beam 6 passes out of the housing via a window 7. The mirror 5 is arranged to oscillate in such a way that the beam 6 traces out a scan line 8 across an indicia 9 to be recorded. Light reflected back from the indicia passes through the window 7, is collected by a collecting mirror 10, and is reflected to a photodetector 11. The optical signal is then converted into an electrical signal and the features of the indicia 9 determined.

In order to modify the bar code scanner a multiple working range optical system described in detail below is included in the system. The system can be inserted at an appropriate point in the path of the light beam reflected from the indicia 9, for example between the window 7 and the collecting mirror 10 or between the collecting mirror 10 and the photodetector 11. Indeed components of the standard bar code scanner such as the collecting mirror can be removed and replaced by the optical system according to the present invention.

The arrangement of FIG. 1 may, in the preferred embodiment, be used in association with the housing shown in FIGS. 3a-3d. FIGS. 3a-3c shows, from left to right, a front, side and perspective view of a pendant-held scanner 20. As discussed below in more detail with reference to FIG. 5 the scanner 20 includes a housing 21 in which are included a light beam generating means such as a laser or light emitting diode, a light-beam-directing means such as a lens system, a scanner window 22 and a detecting means such as a CCD array. The light beam passes through the scanner window, is reflected by a printed indicia such as a bar code symbol and returns to be detected by the detecting means.

It will be seen that the scanner 20 is mounted on a strap 23 and, as shown in FIG. 3d, is carried by a user 24 with the strap 23 around the neck of the user 24. Accordingly if the user wishes to read a bar code symbol 25 on an item 26 the item 26 is simply positioned with the bar code symbol 25 pointing generally towards the user and the bar code symbol 25 is read automatically by the pendant scanner 20. It will be seen that the scanner window 22 is preferably located on the pendant scanner so as to face outwardly.

It will be seen that this arrangement can be advantageously used in association with the multiple range optical scanner system described above; the working ranges of the scanner can be determined to correspond with parameters determined ergonomically by the user; for example a first working range can correspond to the arrangement shown in FIG. 3d in which the item 26 is held at the user's waist level, and a second working range can correspond to an item being held at arms length. The scan area of the scanner 20 is shown in FIG. 3d at 27.

6

FIGS. 4a and 4b show alternative mountings for an optical reader. FIG. 4a shows a point of sale application which could be applied equally in other applications whether the operator remains stationary and it is appropriate to move items to be scanned past the scanner rather than vice versa. A scanner 30 is shown mounted over a conveyor 31 at a point of sale 32. The scanner 30 is mounted on a support such as an arch 33 over a conveyor 31. As items 34 on the conveyor 31 pass under the arch 33 bar code symbols 35 on the items 34 are read by the scanner 30. In the embodiment shown the scanner 30 is roughly the shape of a quadrant of an ovoid with two substantially planar faces, a side face extending in the direction of the long axis of the ovoid and an end face extending in the direction of the short axis to the ovoid. The end face carries a scanning window 37 as shown in FIG. 4b. When mounted on the arch 33 the scanner 30 is oriented with its end face and scanning window 37 pointing downwards towards the bar code symbol 35 to be read.

In a further preferred option the scanner 30 can be detachably mounted on the arch 33 for example by including resilient gripping means on the arch 33. Accordingly the scanner 30 can be removed from the arch 33 and held in the user's hand 38 as shown in FIG. 4b. The end face and scanning window point outwardly away from the user's body and a control button 39 is placed on the planar side face so as to be easily operable by the user's thumb. The curved surface of the scanner 30 then fits snugly and comfortably into the user's hand 38. The scanner 30 can be simply aimed at an article to be scanned and operated by actuating button 39. As a result the scanner 30 can be used in a wide variety of applications and in particular, for example, applications where items are too bulky or heavy or inappropriately positioned to be passed under the arch 31 and scanned.

FIG. 5 shows in more detail the pendant scanner of FIG. 3a-3d incorporating the multiple working range optical arrangement of FIG. 1a. The scanner 20 is shown in partial cross section and partly from one side. The scanner comprises an elongate body having a long broad face 40 for resting against the user's chest when used as a pendant and an opposing face 41 in which is positioned a scanning window 42. The opposing face 41 is preferably slightly curved or otherwise inclined such that the scanning window points at a shallow downwards angle as ergonomically appropriate when the user is holding an item to be scanned at waist level.

The scanner 20 includes a light source 43 such as a laser or LED and a scanning mirror 44 which is rotated in a known manner to oscillate about an axis A. The light beam 45 generated by the laser 43 is reflected by the mirror 44 through the scanning window 42 onto a printed indicia such as a bar code symbol 46 to be read. Light reflected from the bar code symbol 46 passes back through the window 42 and is reflected once more by the mirror 44 via the lens system L_1, L_2 onto a detector 47 such as a CCD array aligned with the image conjugate plane P. As discussed above, narrow band filters NBF_1', NBF_2' are associated with the lenses L_1, L_2 respectively and can be moved in the direction implicated by the double-headed arrows in and out of position in order to select a desired working range. The filters are mounted for reciprocal movement by means of a rack 48 which is driven back and forth by a toothed wheel 49 driven by a motor and controller (not shown). Of course, any suitable method can be used.

It will be appreciated that the lens elements L_1, L_2 can be replaced by any suitable optical arrangements such as holographic elements, prisms or gratings. The narrow band filters may be of any known type.

The desired working range can be selected manually by user input, or automatically by identifying for which working range an object is focused, for example by introducing each of the filters in turn and ascertaining which of the narrow band images is in focus.

An alternative scanner housing is illustrated schematically in FIG. 6a-6c. This is suitable for use with the embodiment of FIG. 1, and/or for the embodiments of FIG. 7 onwards.

The scanner housing of FIGS. 6a to 6c comprises an integrally molded and shaped head portion 100 and manually-graspable handle portion 102. Within the head portion 100 are the scanning optics, for example those shown schematically in FIG. 2. At the front end of the head portion 100 is a window 104 through which the scanning laser beam (not shown) exits the housing, when scanning is initiated by the user pressing the trigger 106. Information on the detected bar code symbol or other indicia is passed out of the scanner along a lead 108 to a base unit (not shown). Strain relief is provided by a flexible strain-relief element 109.

The housing incorporates front and rear feet 110,112, enabling the scanner to be laid down in the position shown on a flat desk top or other surface 114 (FIG. 6a).

One method of achieving multiple working distances, for example within a bar code scanner, has already been described with reference to FIG. 1a. Reference should now be made to FIG. 11 which shows an alternative approach.

This embodiment incorporates dual laser assemblies 1310, 1311 emitting parallel beams. The laser assembly 1310 is focused for short-range operation. This will be referred to, for shorthand, as the "short-range laser". Similarly, the laser assembly 1311 is focused for long-range operation. This will be referred to, for shorthand, as the "long-range laser". Appropriate optics 1312, 1314 define the working range and different beam profile characteristics of the lasers. Alternatively, the short-range laser, and its optics, may be identical with the longrange laser and its optics.

The beam from the long-range laser 1311 is reflected by a pair of parallel angled mirrors (or by an appropriately shaped prism) so that the two resultant laser beams are closely parallel to each other. The beams impinge upon a scanning mirror 1322 from which they are reflected onto an indicia to be read (not shown, but off to the left of the drawing in FIG. 11).

Instead of there being separate long range and short range lasers, a single laser could be used instead with appropriate optics (for example a beam splitter).

Light reflected back from the indicia is collected by the mirror 1322 (which acts as a collection mirror as well as a scanning mirror) and is directed to a photodetector 1324).

Details of the mirror 1322 are shown in FIG. 12. As will be seen, the mirror is generally curved, and includes a large area of collecting surface 1323 with a central section which is split into two. The left side of the central section 1325 has a cylindrical profile, and the right hand section 1327 a flat profile. The light beam from the short-range laser 1310 impinges upon the portion 1325, and the light from the long-range laser 1311 impinges upon the portion 1327.

In use, a laser control 1326 operates the lasers so that they are switched on and off alternately. The system is controlled so that two scans (left to right, then right to left) are performed with the long-range laser on, and then two scans with the short-range laser on. The alternation continues until a successful decode has been achieved.

The system also provides for an aiming mode which is initiated by a user selecting a first position of a trigger 1328 on the scanner housing 1330. In this mode, the controller 1326 causes the long-range laser 1311 to blink on and off while moving the mirror 1322. In this mode the user can easily see the scanning beam and he can align the indicia accordingly. As soon as the indicia has been properly aligned with respect to the scanner, the user moves the trigger 1328 to a second position to commence scanning proper.

In another embodiment, the laser assemblies 1310, 1311 have lasers of different frequencies. Visible laser diodes are now available in two different wavelengths, 635 nm and 670 nm. The shorter wavelength device (635 nm) is more visible to the eye, and may preferably be used in high ambient light conditions or for aiming. Thus, in the preferred implementation, the 670 nm laser diode could be focused as the "short range laser" and the 635 nm laser diode focused as the "long range laser" since at long range the brightest beam is desirable for visibility and aiming. In high ambient light conditions, it is possible to use both lasers on, rather than alternate between the lasers. Although there will be two beams, if the beams are properly focused at the target plane so the spots are overlapping or very closely adjacent, the bar code symbol can be effectively read.

In still another embodiment, one of the laser assemblies 1310, 1311 is a visible laser and the other assembly an IR laser, whose beam is generally not visible to the eye. IR lasers are suitable for use in applications such as reading security badges that require an IR reading beam, reading direct thermal printed bar codes; and reading certain colored bar codes. The same arrangement as shown in FIG. 11 may be used, except there is no limitation that the optics be "short range" or "long range". As in the previous embodiment, one can alternate scans between lasers or use both lasers on.

Yet another embodiment is shown in FIG. 7. Here lasers 201,202 are used, each having its own separate focusing optics 203,204. The optics differ in focal length, giving the two laser beams 205,206 differing points of focus and hence differing working ranges. Both beams are scanned by a scanning mechanism such as an oscillating mirror 207, and are directed towards an indicia 208 to be read. It will be understood that because of the differing focus lengths of the optics 203,204, only one of the two scanning beams will properly be in focus at the indicia 208. If the distance to the indicia is small, the beam corresponding to the optics of shorter focal length will be in focus; if the distance is large, the other beam will be in focus.

Light 210 which has been reflected from the indicia 208 is collected by a collecting mirror 211, and passed to a photodetector 212. This produces an electrical output signal on a line 213 which is representative of the changes in intensity within the reflected light.

The lasers 201,202 are repeatedly pulsed by a controller 260, at the same rate but out of phase so that one laser is on while the other is off. The controller also sends a signal along a line 261 to a time divisional sampler and demultiplexer 214 which accepts as input the signals on the line 213, and separates them out into a first pulse stream on a line 215 representing pulses from the first laser 201, and a second pulse stream on a second line 216 representing pulses from the second laser 202. In order to ensure that the sampling is accurate, the-time division demultiplexer 214 samples at a rate greater than the Nyquist limit (twice the highest frequency contained in the signal on the line 213).

The individual pulse streams on the lines 215,216 are each individually processed by respective decoders 217,218 to

provide respective high level outputs **219,220**. The simultaneous processing/decoding allows for the indicia **208** to be decoded without delay, regardless of whether it is positioned at a distance suitable for scanning by the laser **201**, or at a distance suitable for scanning by the laser **202**. It will be understood, of course, that typically only one of the decoders **217,218** will produce a "valid decode" output for a given indicia at a given distance from the scanner.

FIG. **8** shows a variant of the embodiment of FIG. **7**, with identical elements being given identical reference numerals. In this variant, the lasers are pulsed by the controller **260** at two different and unrelated frequencies. For the sake of discussion it will be assumed that the laser **201** is pulsed at a frequency f_1 , and the laser **202** at a frequency f_2 ; it will further be assumed that the signal bandwidth is f_s .

The output signal on the line **213** is then sampled at **229**, and the sampled signal is passed through two bandpass filters **230,231**. The filter **230** has a passband of f_1 plus or minus f_s , whereas the second filter **231** has a passband of f_2 plus or minus f_s . This filtering separates the output of the two lasers in the frequency domain, so that the output of the filter **230** on the line **232** represents the signal just from the laser **201**, and the output from the filter **231** on the line **233** represents just the other laser **202**. The two signals are processed/decoded simultaneously by respective decoders **234,235** to produce individual outputs **236,237**. As before, this simultaneous decoding eliminates delay.

In either the embodiment of FIG. **11**, or the embodiments of FIGS. **7** and **8**, the laser beams may if desired be directed onto two separate regions within the field of view. This could be achieved either by providing an appropriate spacing between the parallel laser beams, or by arranging for the laser beams to be slightly out of parallel alignment. The light which has been reflected from the two respective regions in the field of view may then be sensed simultaneously to produce two data streams which are related to the detected light intensity in the respective two regions. From those two data streams, a single decoded representation may be derived.

Depending on the set-up of the lasers, the reflected light from the two regions may differ either in intensity, frequency, or pulsing frequency. Such differences provide a convenient way of discriminating between light which has been reflected from the individual regions, thereby enabling the two data streams to be conveniently separated. This applies whether the two regions are entirely separate from each other within the field of view, or whether they overlap.

It will be understood that both the embodiment of FIG. **7** and the variation of FIG. **8** is not restricted to the use of exactly two lasers. As many lasers may be used as is required, with different working ranges for each.

In some implementations it may be desirable not only to change the working distance, but also to change the scan pattern generated by an optical scanner. This may be achieved by means of the embodiment of FIG. **9**.

A laser **300** generates a beam **302** which is focused and shaped by beam optics **304** and directed to a stationary flat mirror **306**. The beam is reflected from the mirror and onto a rotating polygon **308**, which is driven for rotation about an axis **309**. The reflections from the polygon produce a scanning laser beam **310**.

The scanning beam next impinges upon an arrangement of fixed mirrors **312** in a crown configuration, with the various reflections **315** from the individual mirrors making up the crown, as the scanning beam **310** moves across, resulting in the omni-directional scan pattern shown in FIG.

10a. In order to achieve this pattern, all of the reflecting surfaces are appropriately coated to provide a high level of reflectivity at the wavelength of the laser **300** (preferably 670 nm).

The scanning mechanism shown in FIG. **9** further includes an additional laser **300'** having its own optics array **304'**. This laser operates at a different wavelength than the laser **300**, and preferably at a wavelength of about 630 nm. By coating only some of the relevant surfaces for reflection at 630 nm, other scan patterns may be generated. For example, if only the central mirror element **314** of the crown is coated for reflection at 630 nm, the scan pattern of FIG. **10b** may be generated. Other scan patterns could be created by selectively coating one or more of the other mirror elements **316, 318, 320, 322**. In addition, further permutations may be obtained by coating only some of the surfaces of the rotating polygon **308** for reflection at 630 nm. For example, if only one surface **324** of the polygon is coated, along with the central mirror element **314** of the crown, one can obtain the single line scan pattern shown in FIG. **10c**.

By coating all of the relevant surfaces for reflection at 670 nm, and only some of the surfaces for reflection at 630 nm, two different scan patterns may be generated by user selection or automatic selection of the appropriate laser. Manual selection could be achieved by means of a user-operable trigger, such as the trigger **3** shown in FIG. **2**; automatic control could be achieved by arranging for the scanner to detect the type of bar code symbol being scanned, and automatically selecting the scan pattern accordingly.

A further benefit of the method is that the 630 nm beam may be focused differently from the 670 nm beam.

It will be understood of course that more than two lasers could be used, each having a different wavelength. The described wavelengths of 670 and 630 nm, while preferred, could be varied if necessary accordingly to the particular application.

It will be appreciated, in connection with FIG. **9**, that a variety of other methods could be used to achieve the same effect. In FIG. **9**, the beams of differing wavelengths are selected by means of coatings, but of course it would also be possible to select the beams by conventional filters attached to or positioned in front of the mirrors. It would also be possible to separate the wavelengths using holographic elements and/or diffraction gratings. Where coatings are used they may be applied, as a thick layer, to a conventional mirror, thereby acting as a conventional filter to block light of a certain wavelength. Alternatively, the coatings may be a thin layer, arranged to reinforce or to cancel out the incident waveform by optical interference techniques.

While the optical system of FIG. **1** has been described in relation to a bar code reader it will be appreciated that it could equally be used in any optical arrangement requiring differing working ranges. For example the invention could be used in conjunction with a CD ROM pick-up, a camera, a telescope or other optical systems.

While the invention has been illustrated and described with reference to a number of particular embodiments, it is not intended to be limited to any of the details shown, since various modifications and structural changes may be made without departing in any way from the spirit of the present invention.

Without further analysis, the foregoing will so fully reveal the gist of the present invention that others can, by applying current knowledge, readily adapt it for various applications without omitting features that, from the stand point of prior art, fairly constitute essential characteristics of the generic or

11

specific aspects of this invention. Accordingly, such adaptations should be and are intended to be comprehended within the meaning and range of equivalence of the following claims.

We claim:

1. An optical scanner for reading indicia having parts of different light reflectivity, comprising:

a) an optical assembly for producing a plurality of light beams of different wavelengths; and

b) a scan pattern generator, including a wavelength selector for selecting a first of the beams to produce a first scan pattern, and for selecting a second of the beams to produce a second scan pattern, the scan patterns having a different number of scan lines, and the scan pattern generator being operative for scanning the selected scan pattern over the indicia to be read.

2. The scanner according to claim 1, wherein the optical assembly includes a plurality of lasers for producing the light beams as laser beams.

3. The scanner according to claim 2, wherein the first laser beam has a wavelength of 670 nm, and wherein the second laser beam has a wavelength of 630 nm.

4. The scanner according to claim 2, wherein the optical assembly includes a plurality of optical lenses, each of the lenses being respectively associated with a respective laser, for optically modifying the respective laser beam.

5. The scanner according to claim 1, wherein the scan pattern generator includes a plurality of optical elements, each of the elements having different optical properties when the light beams of different wavelengths are incident on a respective element.

6. The scanner according to claim 5, wherein the elements are mirrors, at least one of the mirrors having a wavelength-selective coating thereon.

7. The scanner according to claim 6, wherein the coating has a predetermined thickness.

8. The scanner according to claim 6, wherein all the mirrors have the wavelength-selective coating thereon.

9. The scanner according to claim 6, wherein the coating is operative for reflecting only one of light beams.

10. The scanner according to claim 5, wherein the elements are mirrors, at least one of the mirrors being mounted for movement relative to the optical assembly.

11. The scanner according to claim 10, wherein others of the mirrors are stationarily mounted within the scanner.

12

12. The scanner according to claim 11, wherein the others of the mirrors are arranged along an arc.

13. The scanner according to claim 5, wherein one of the scan patterns is an omni-directional scan pattern.

14. The scanner according to claim 1, wherein the wavelength selector is operative for manually selecting one of the beams.

15. The scanner according to claim 1, wherein the wavelength selector is operative for automatically selecting one of the beams.

16. A method of reading indicia having parts of different light reflectivity, comprising the steps of:

a) producing a plurality of light beams of different wavelengths;

b) selecting a first of the beams having a first wavelength to produce a first scan pattern, and selecting a second of the beams having a second wavelength to produce a second scan pattern, the scan patterns having a different number of scan lines.

17. The method according to claim 16, wherein the producing step is performed by producing the light beams as laser beams.

18. The method according to claim 17, wherein the first laser beam has a wavelength of 670 nm, and wherein the second laser beam has a wavelength of 630 nm.

19. The method according to claim 16, wherein the selecting step is performed manually.

20. The method according to claim 16, wherein the selecting step is performed automatically.

21. The method according to claim 16, wherein the selecting step is performed by providing a plurality of optical elements, each of the elements having different optical properties when the light beams of different wavelengths are incident on a respective element.

22. The method according to claim 21, wherein the elements are mirrors, and wherein the selecting step is performed by applying a wavelength-selective coating on at least one of the mirrors.

23. The method according to claim 22, wherein the applying step is performed by applying the coating on all of the mirrors.

24. The method according to claim 21, wherein the elements are mirrors, and wherein the scanning step is performed by moving at least one of the mirrors.

* * * * *