

US00RE40084E

(19) **United States**
(12) **Reissued Patent**
Petersen et al.

(10) **Patent Number:** **US RE40,084 E**
(45) **Date of Reissued Patent:** **Feb. 19, 2008**

- (54) **OPTICAL PROXIMITY CORRECTION**
- (75) Inventors: **John S. Petersen**, Austin, TX (US);
Jang Fung Chen, Cupertino, CA (US)
- (73) Assignee: **ASML Masktools Netherlands B.V.**,
Veldhoven (NL)
- (21) Appl. No.: **11/055,790**
- (22) Filed: **Feb. 11, 2005**

5,256,505 A	*	10/1993	Chen et al.	430/5
5,288,569 A	*	2/1994	Lin	430/5
5,324,600 A	*	6/1994	Jinbo et al.	430/5
5,362,584 A	*	11/1994	Brock et al.	430/5
5,424,154 A	*	6/1995	Borodovsky	430/5
5,436,095 A	*	7/1995	Mizuno et al.	430/5
5,447,810 A	*	9/1995	Chen et al.	430/5
5,538,815 A	*	7/1996	Oi et al.	430/5
5,663,893 A	*	9/1997	Wampler et al.	364/491
5,707,765 A	*	1/1998	Chen	430/5
5,723,233 A	*	3/1998	Garza et al.	430/5
5,821,014 A	*	10/1998	Chen et al.	430/5
5,827,623 A	*	10/1998	Ishida et al.	430/5
6,114,071 A	*	9/2000	Chen et al.	430/5

Related U.S. Patent Documents

Reissue of:

- (64) Patent No.: **6,541,167**
Issued: **Apr. 1, 2003**
Appl. No.: **09/840,307**
Filed: **Apr. 24, 2001**

U.S. Applications:

- (63) Continuation-in-part of application No. 09/562,445, filed on May 1, 2000, now Pat. No. 6,335,130.

- (51) **Int. Cl.**
G03F 1/00 (2006.01)

- (52) **U.S. Cl.** **430/5**

- (58) **Field of Classification Search** 430/5,
430/30, 322; 355/53, 73, 76
See application file for complete search history.

- (56) **References Cited**

U.S. PATENT DOCUMENTS

5,229,255 A	*	7/1993	White	430/311
5,242,770 A	*	9/1993	Chen et al.	430/5

FOREIGN PATENT DOCUMENTS

WO	WO 99/27420	*	6/1999
WO	WO 99/47981	*	9/1999

* cited by examiner

Primary Examiner—S. Rosasco

(74) *Attorney, Agent, or Firm*—McDermott Will & Emery LLP

- (57) **ABSTRACT**

Method for utilizing halftoning structures to manipulate the relative magnitudes of diffraction orders to ultimately construct the desired projected-image. At the resolution limit of the mask maker, this is especially useful for converting strongly shifted, no-0th-diffraction-order, equal-line-and-space chromeless phase edges to weak phase-shifters that have some 0th order. Halftoning creates an imbalance in the electric field between the shifted regions, and therefore results in the introduction of the 0th diffraction order.

31 Claims, 34 Drawing Sheets

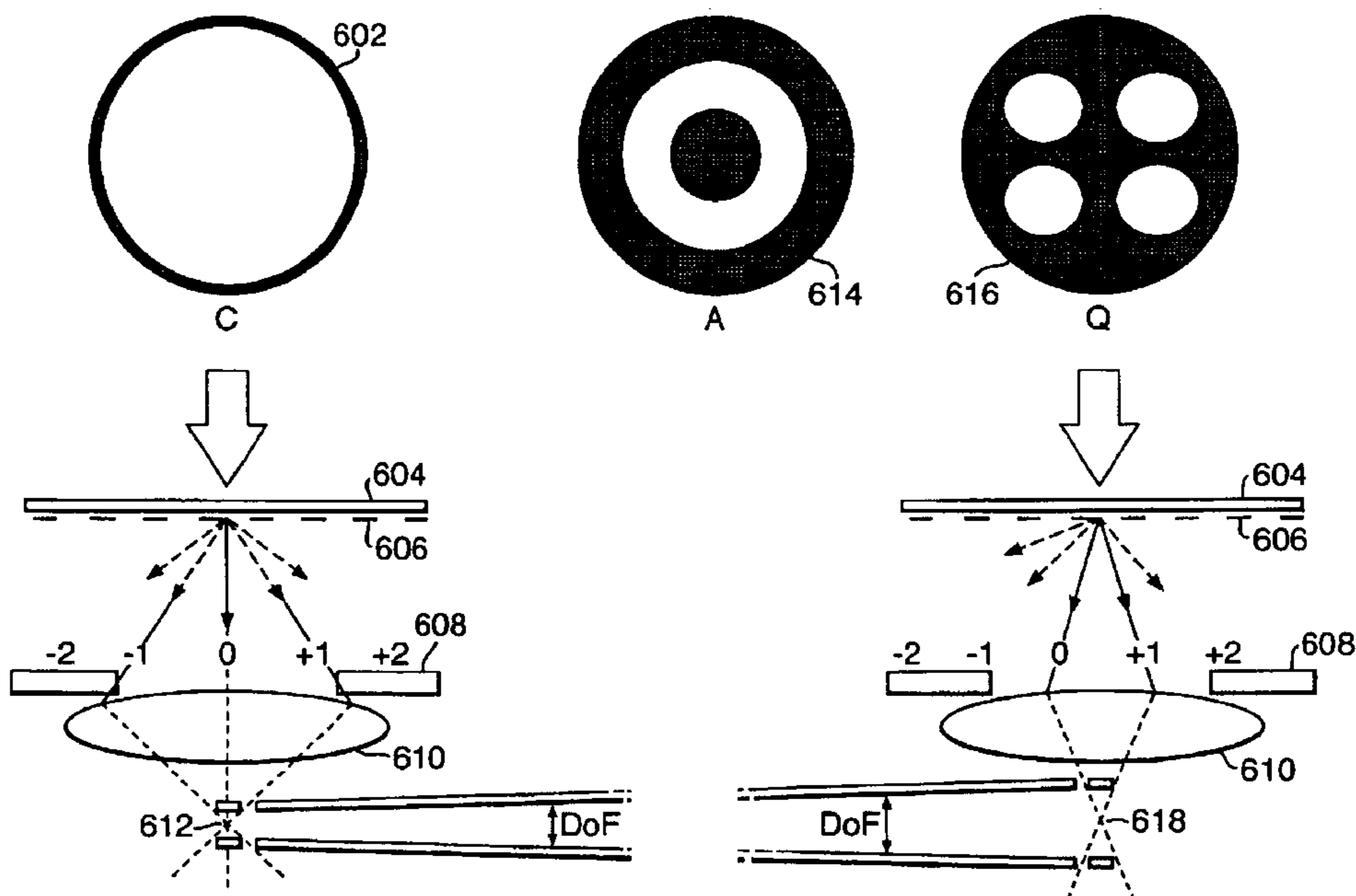

Fig. 1.

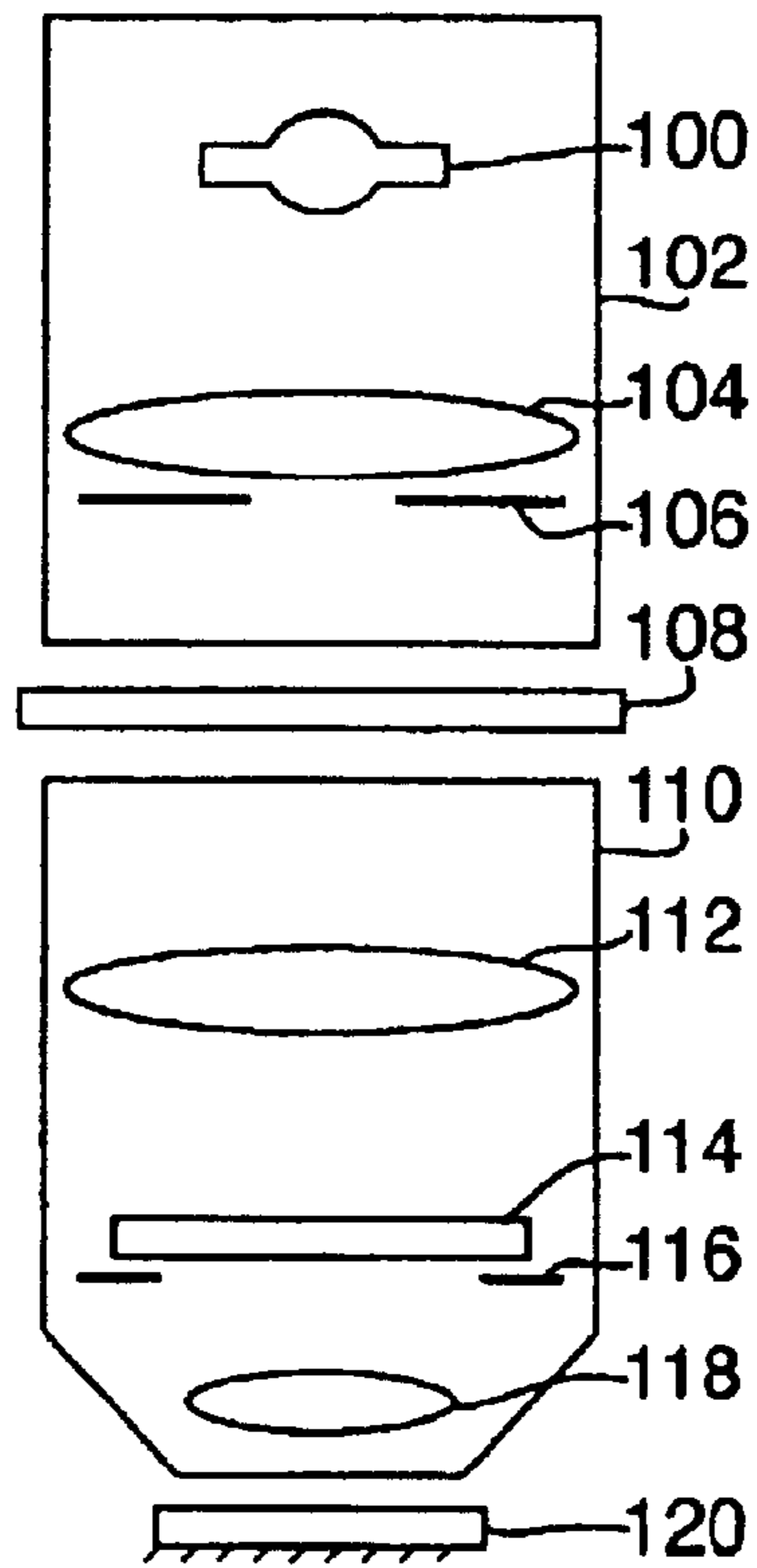

Fig. 2.

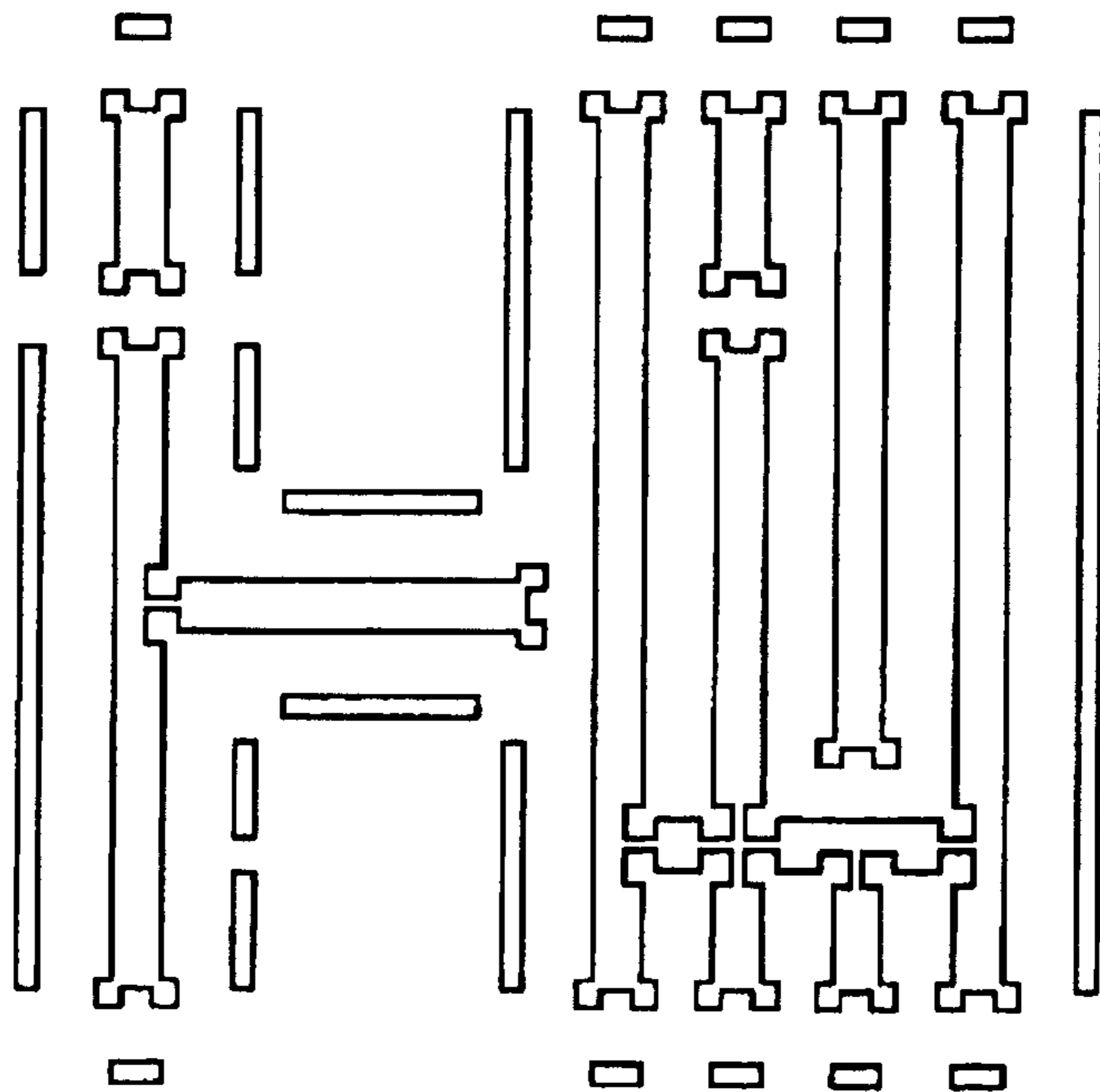

Fig.3(A).

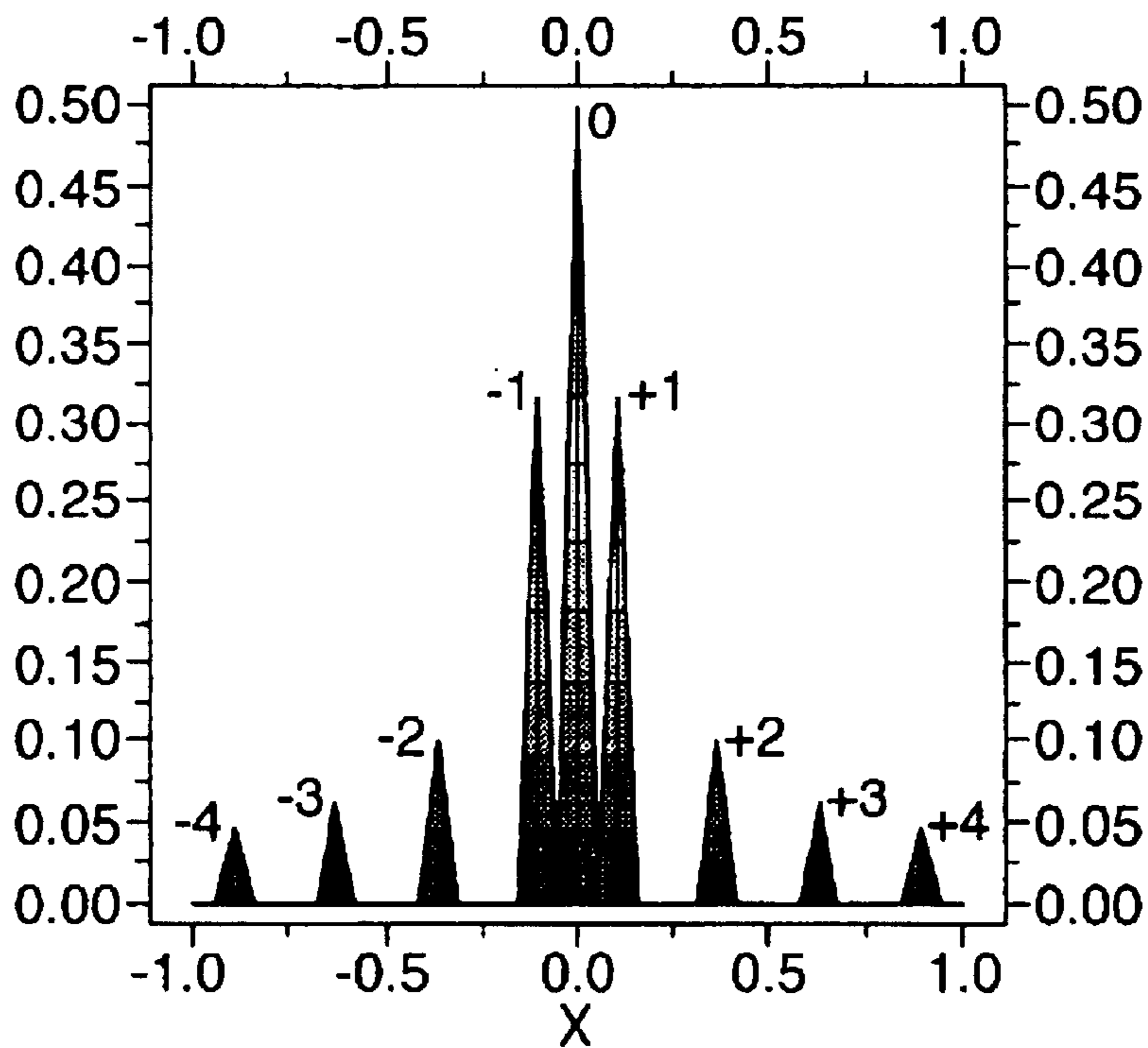

Fig.3(B).

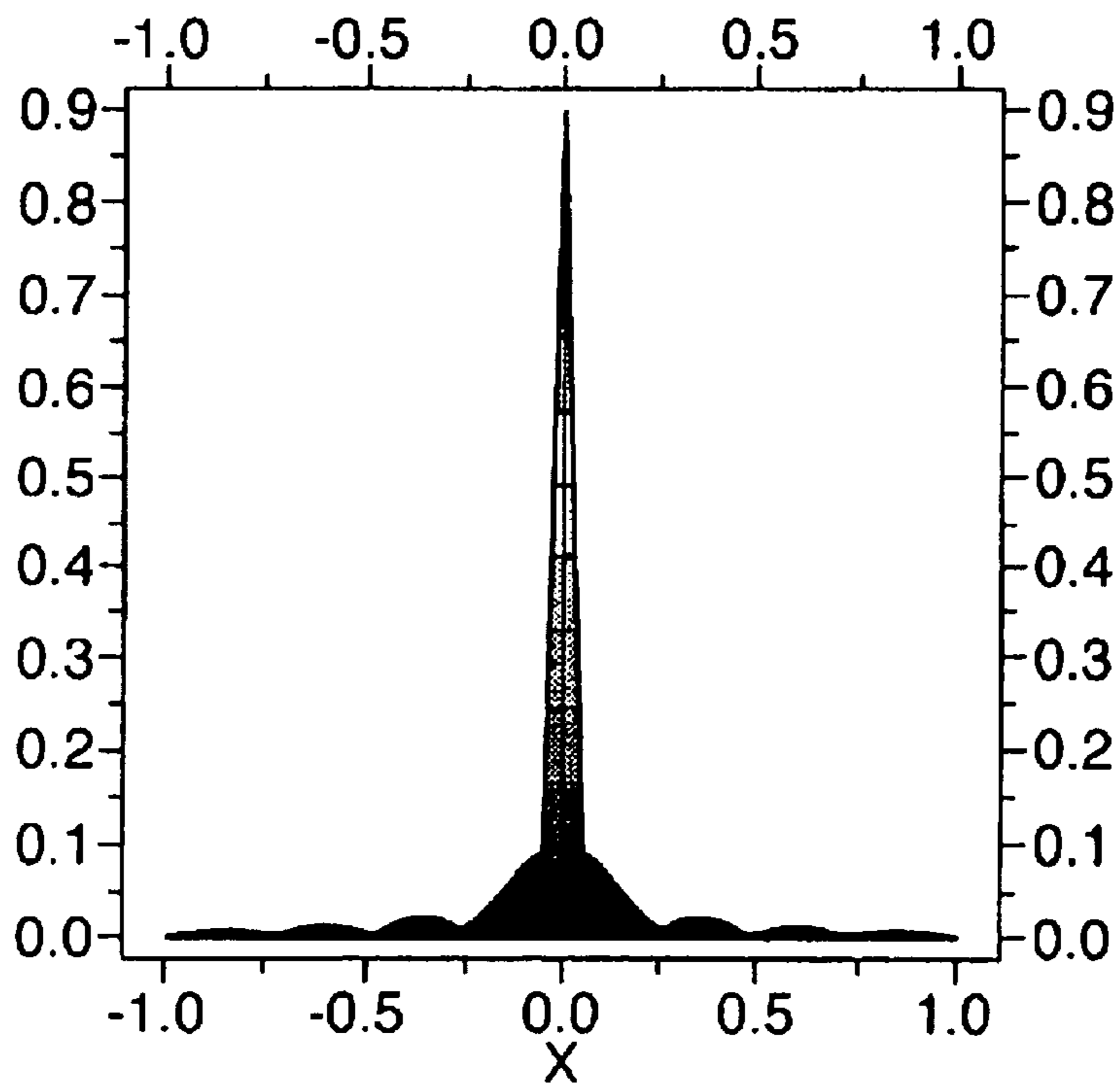

Fig.4(A).

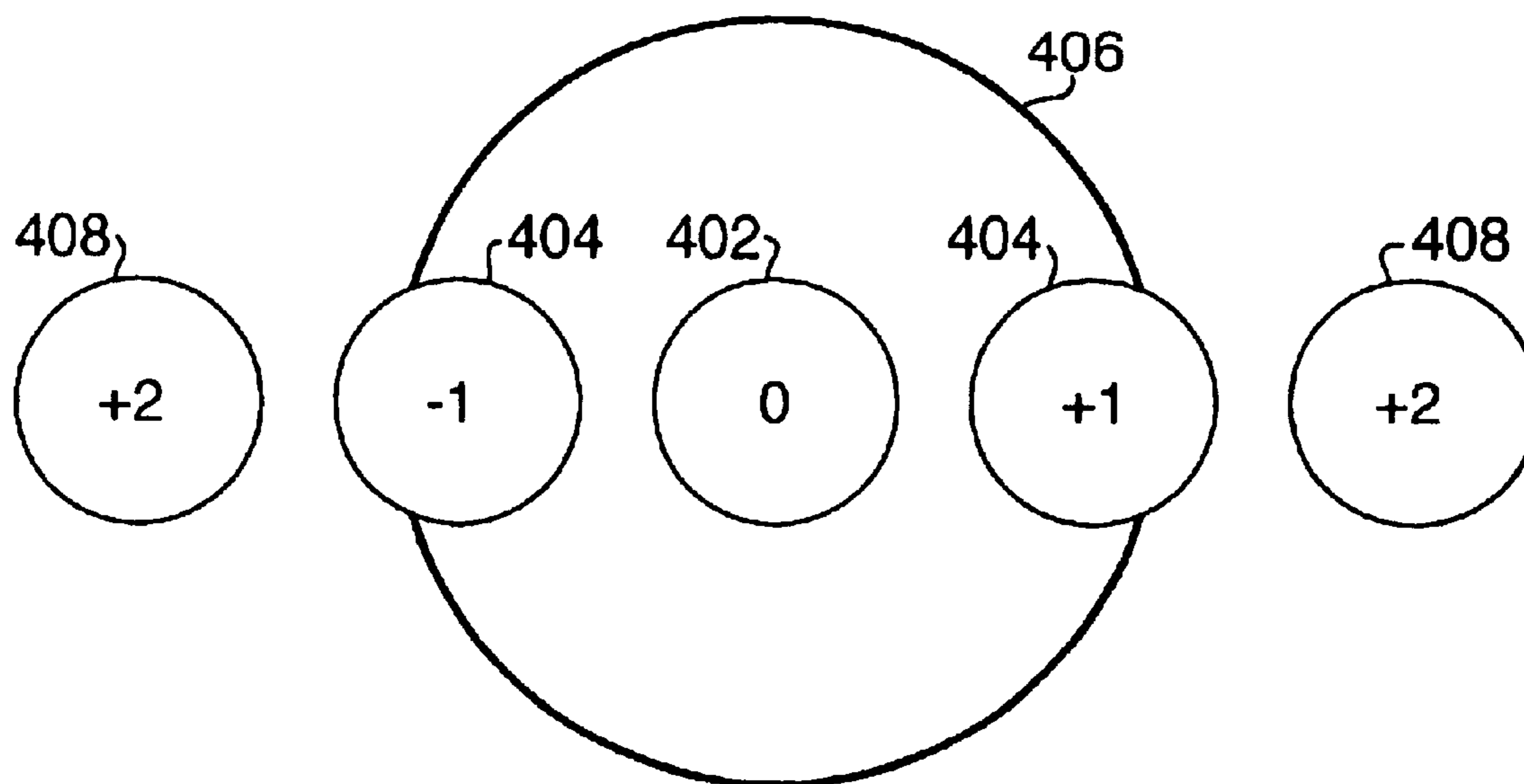

Fig.4(B).

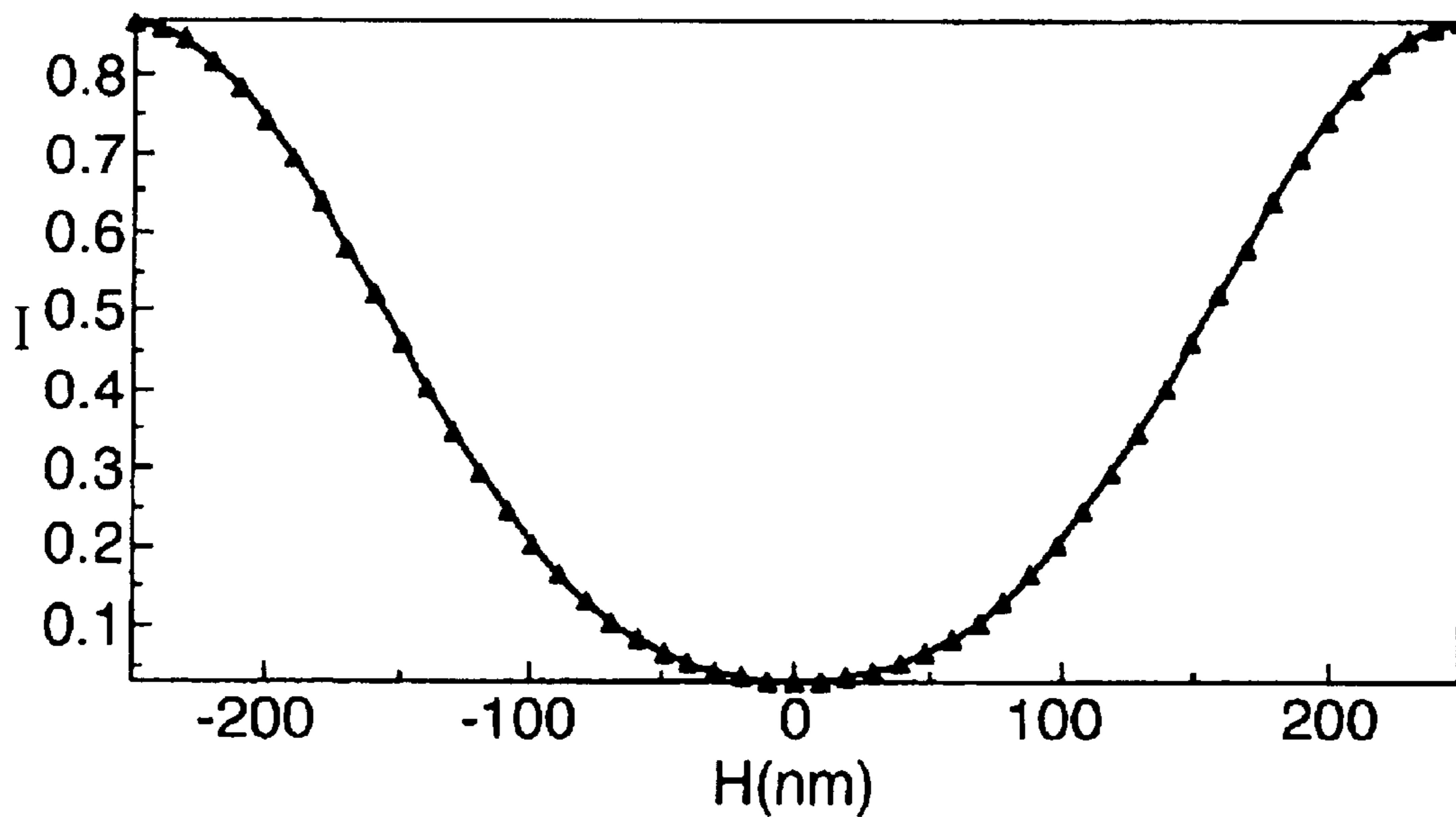

Fig.5(A).

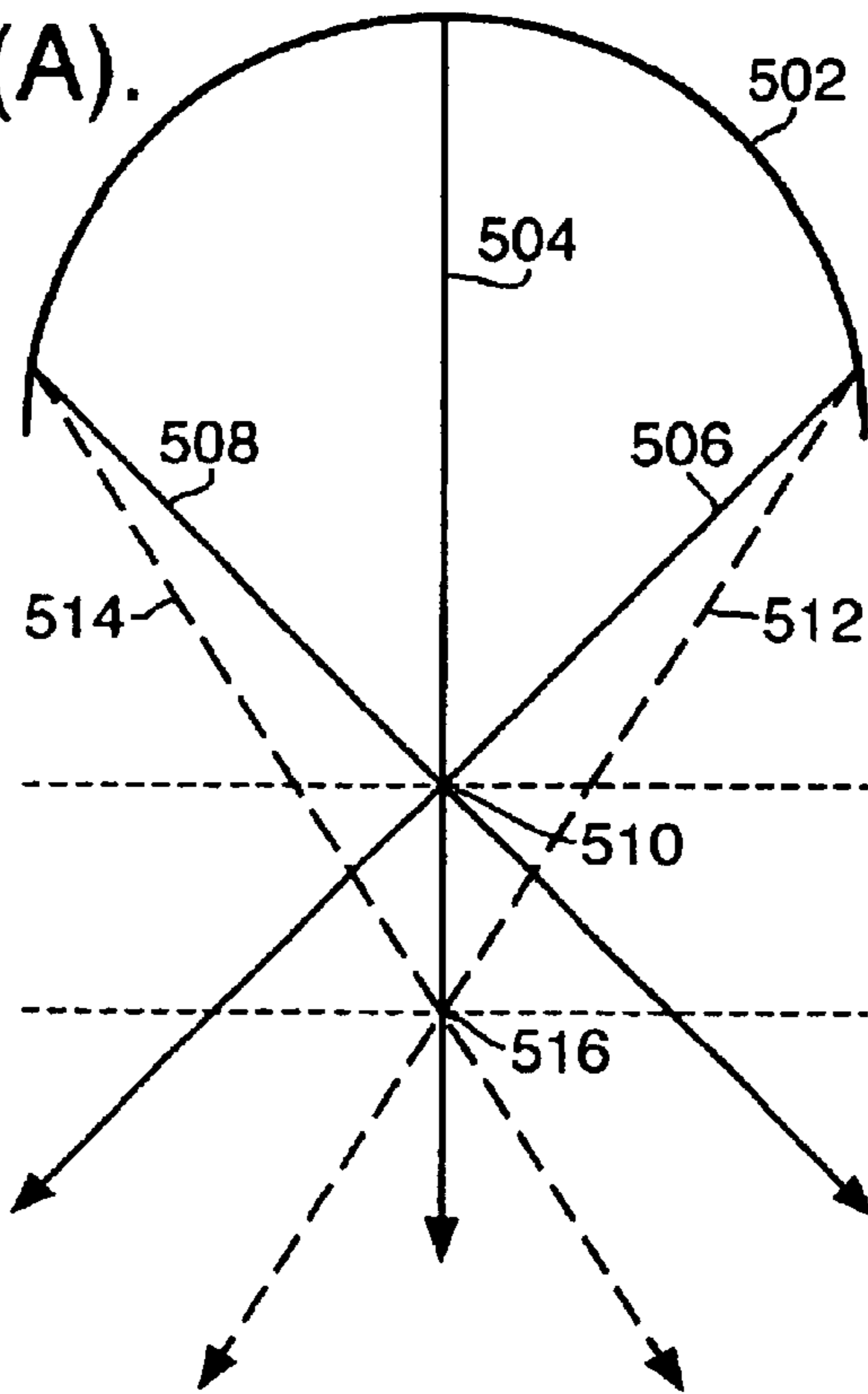

Fig.5(B).

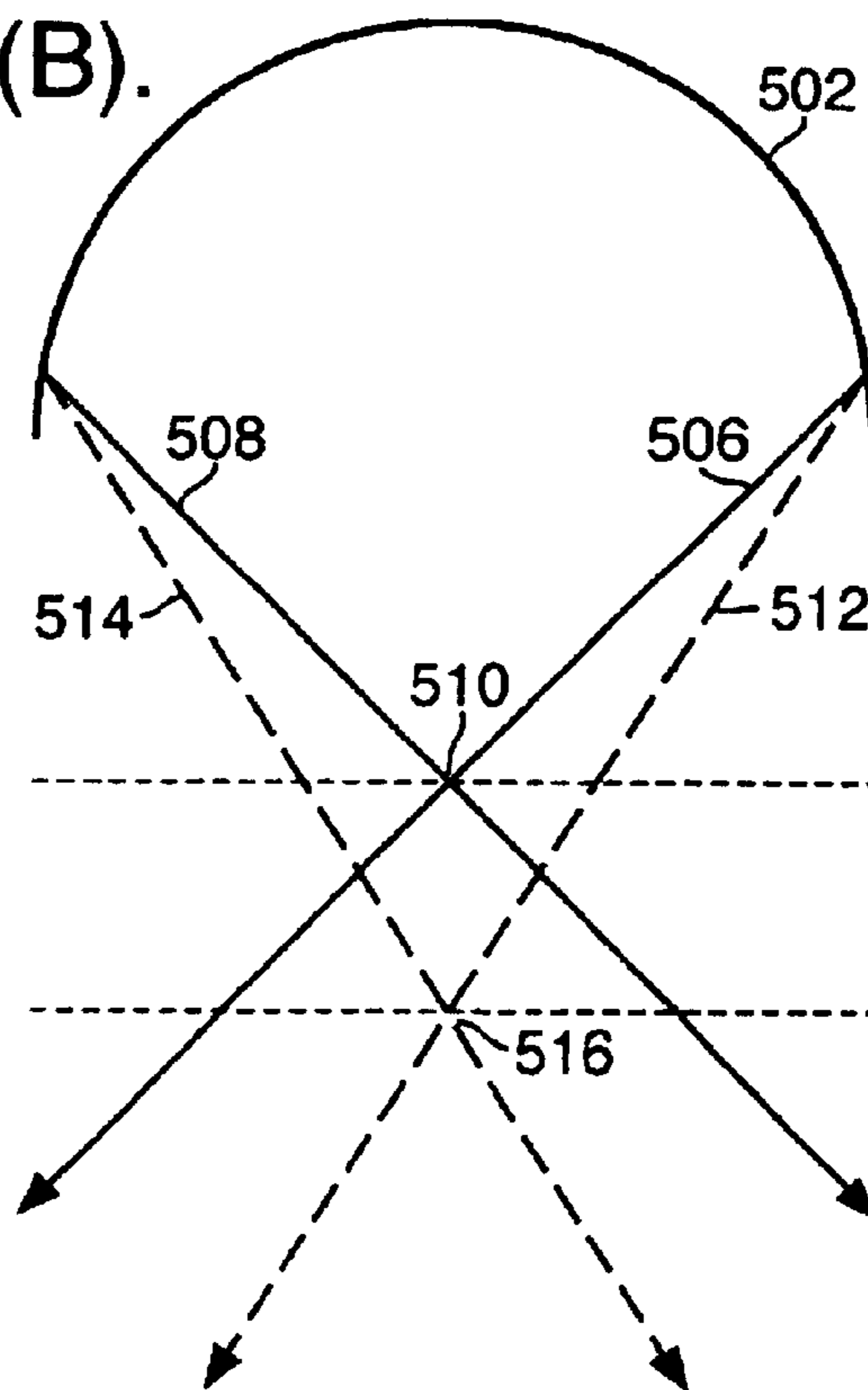

Fig. 6(A).

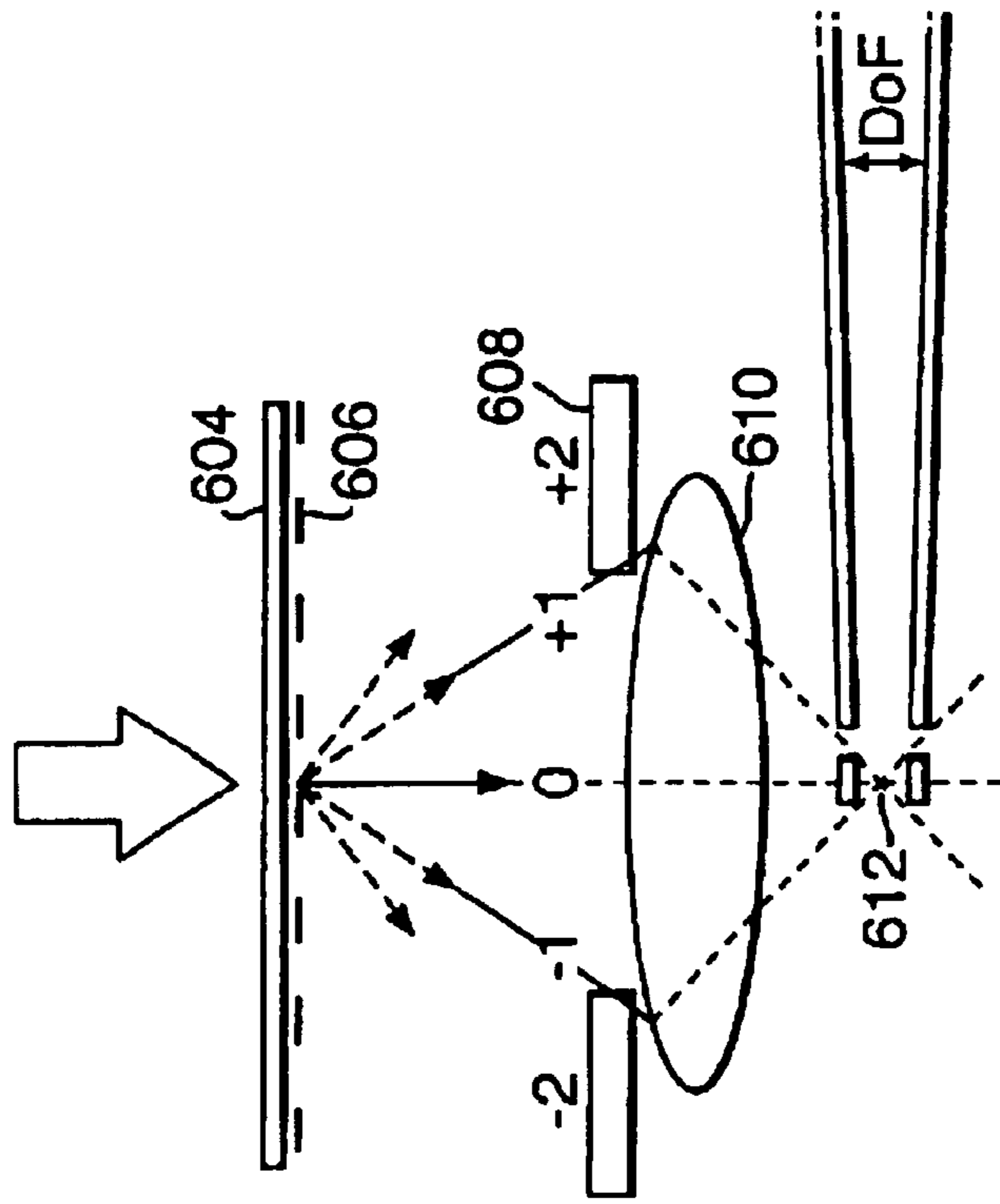
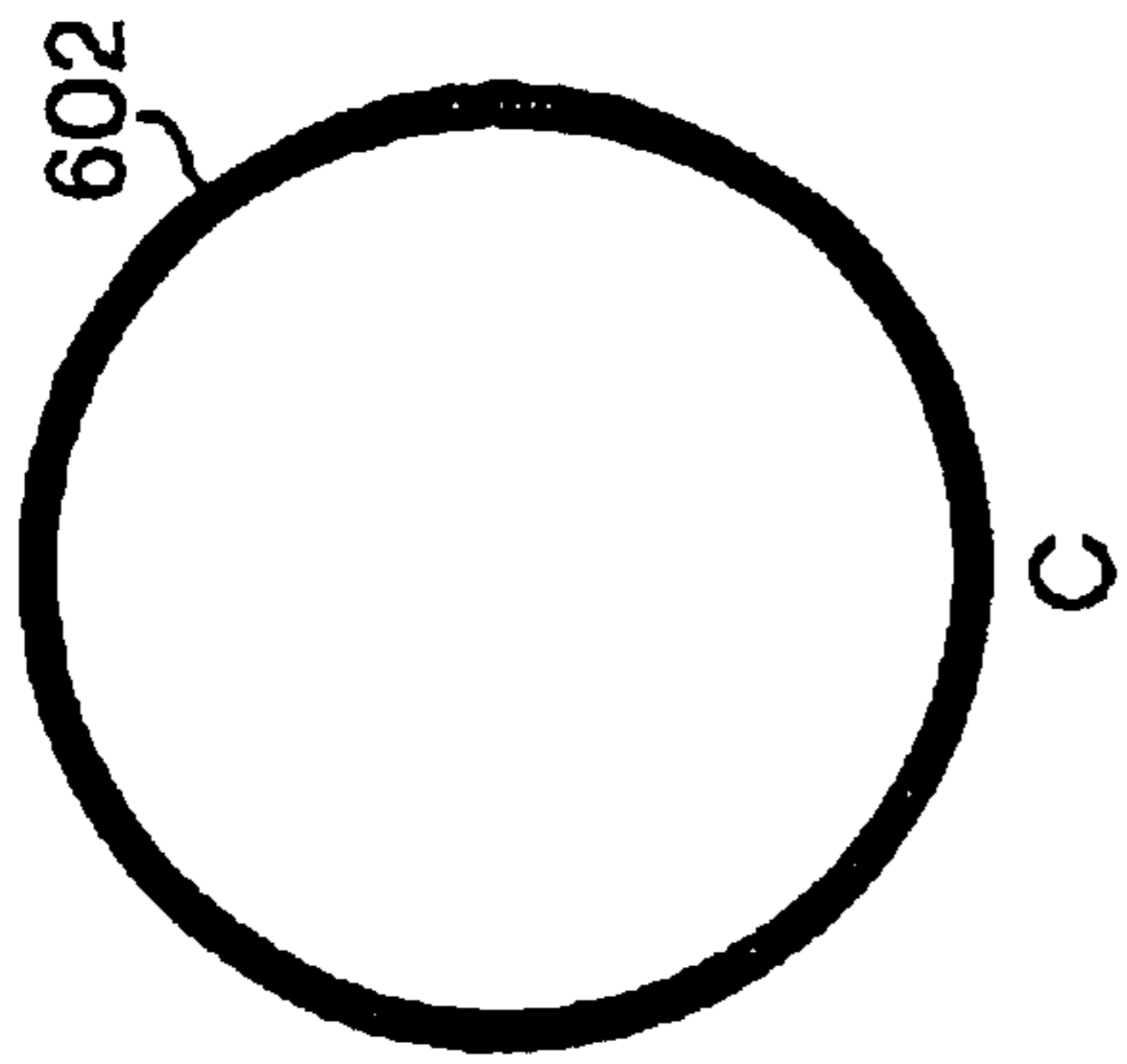

Fig. 6(B).

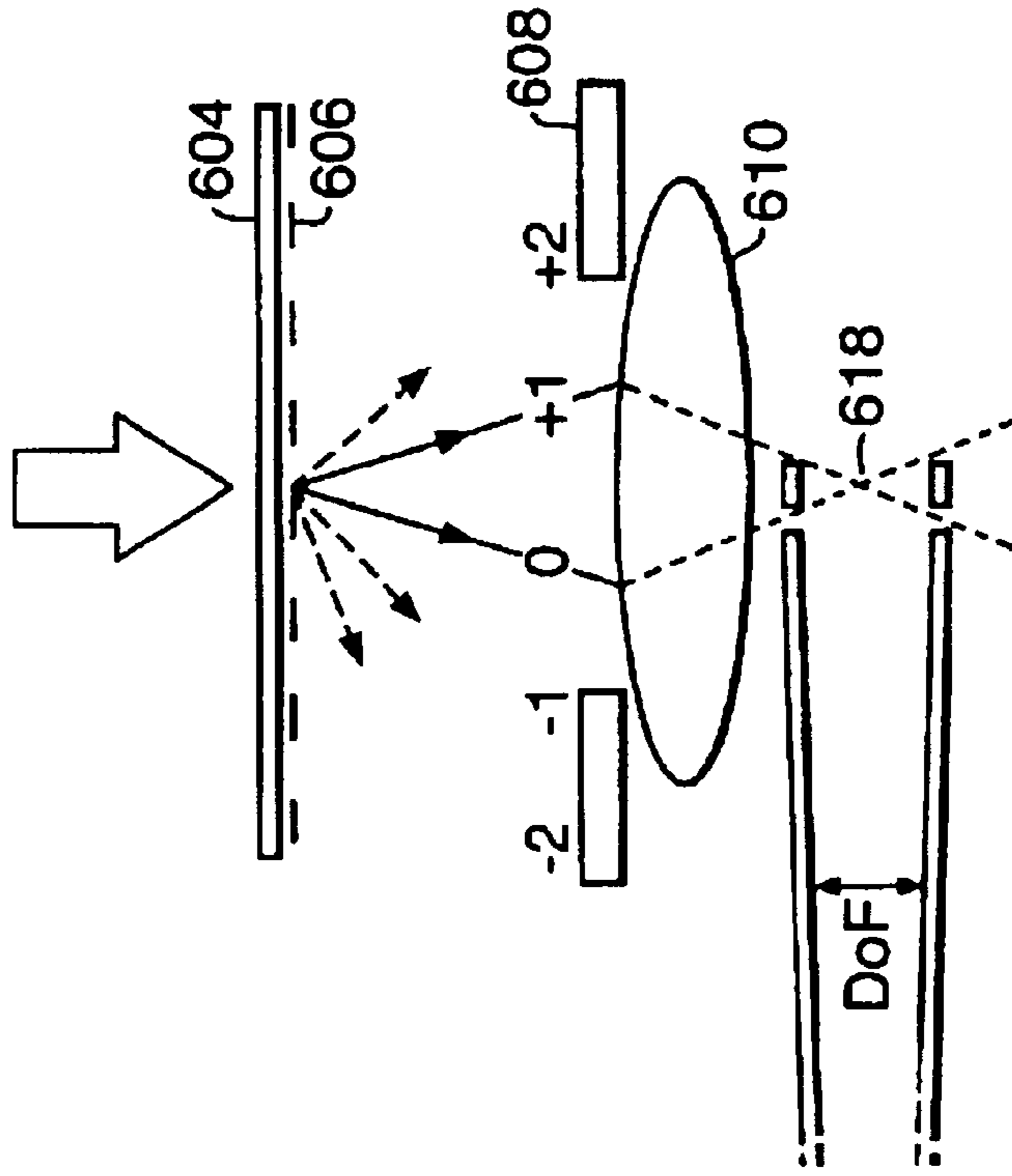
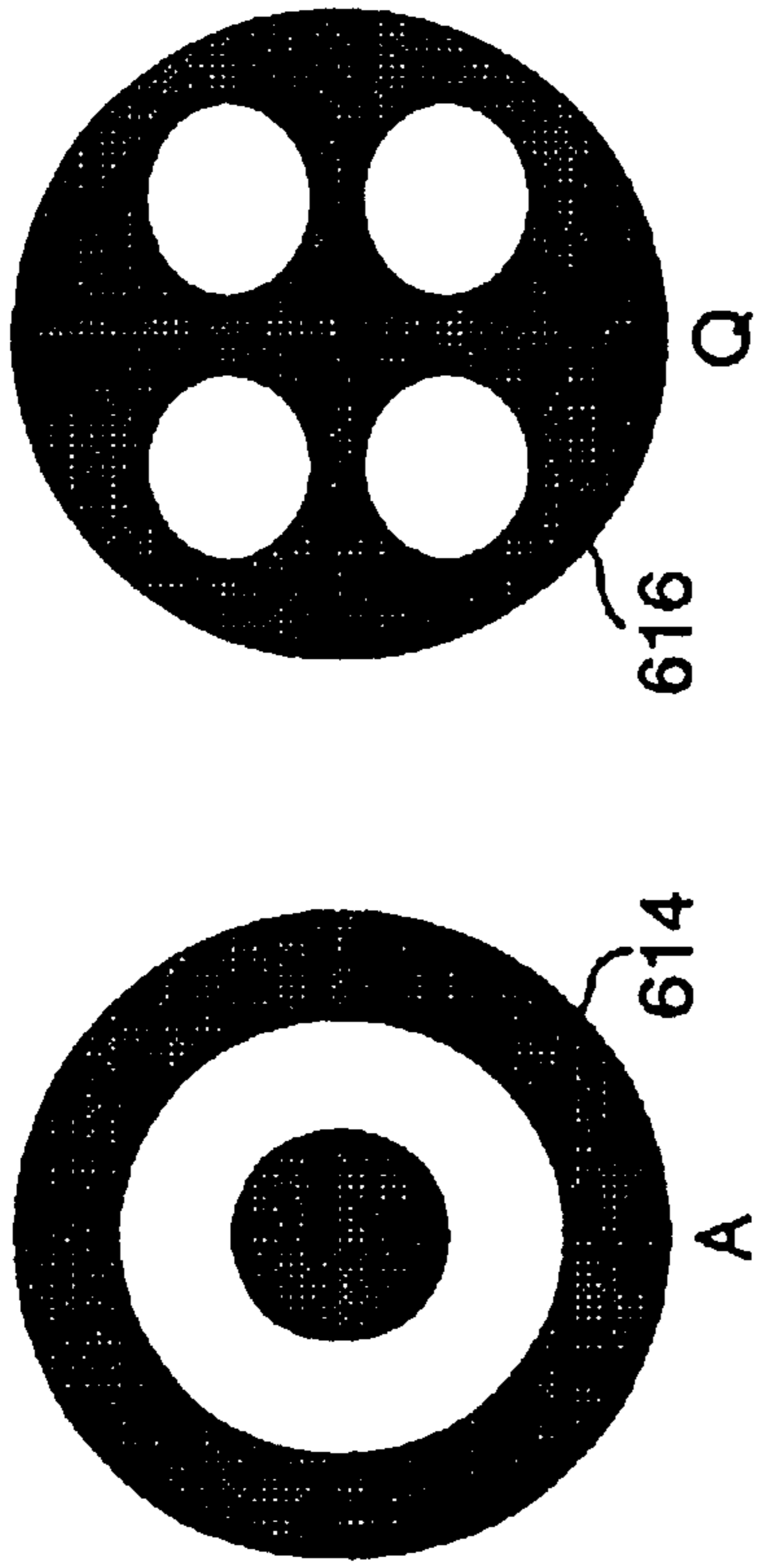

Fig.7(A).

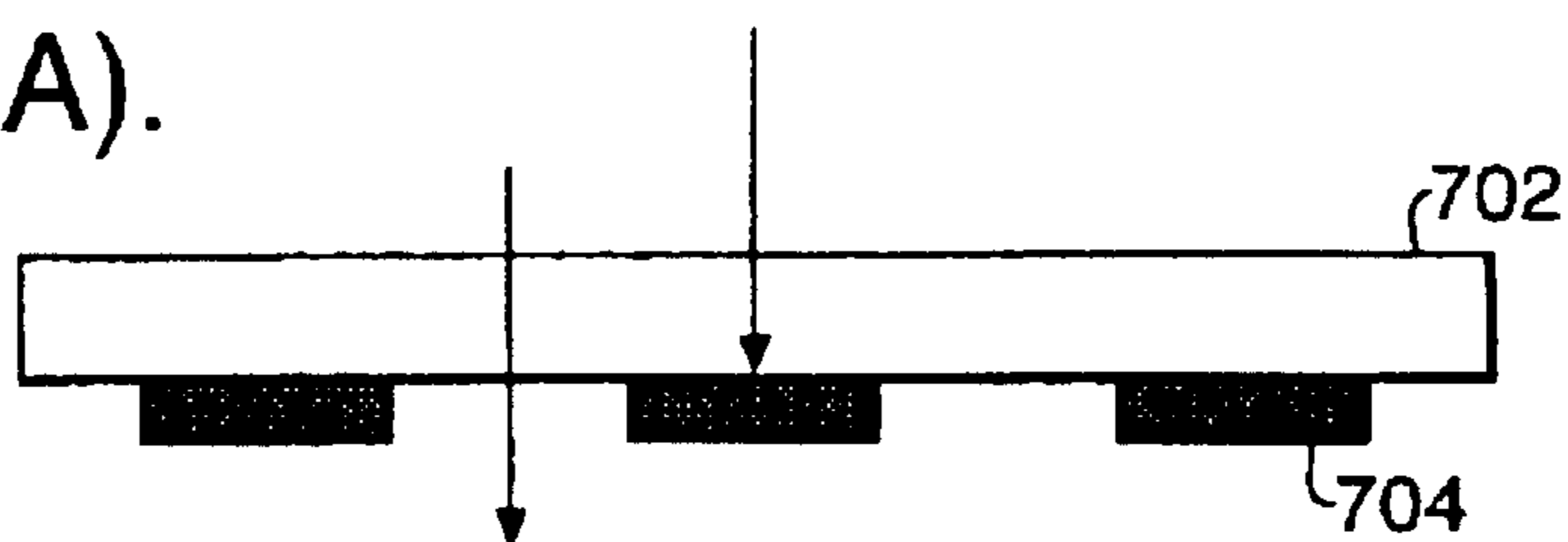

Fig.7(B).

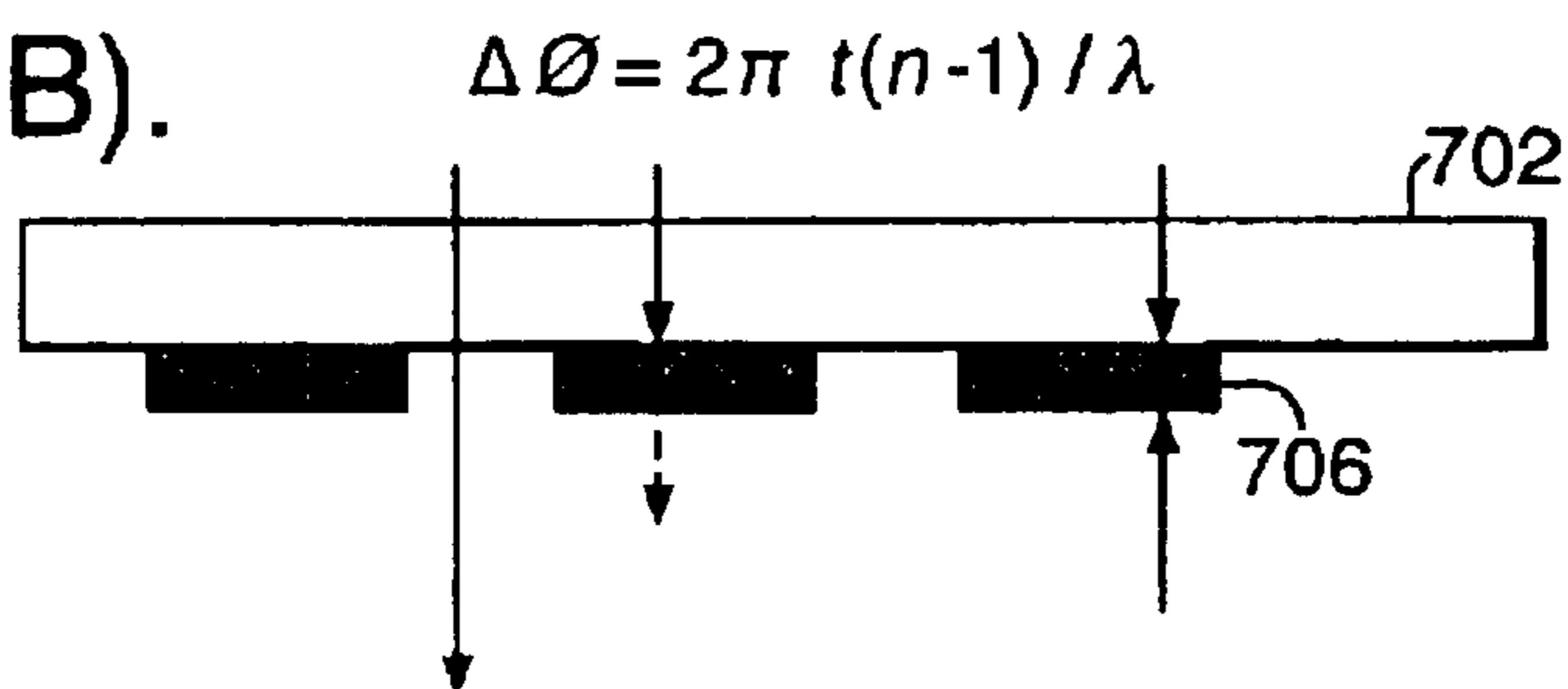

Fig.7(C).

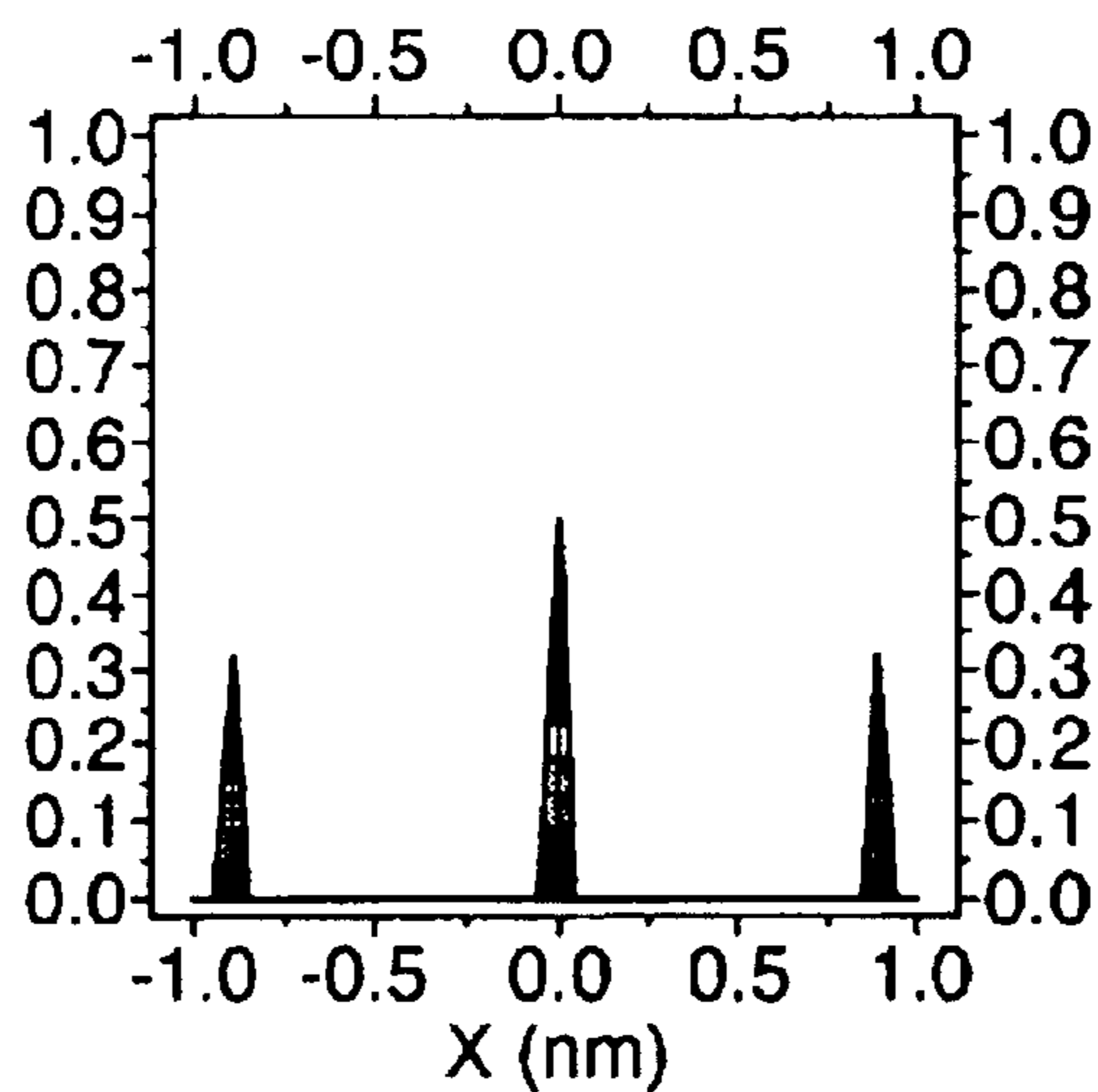

Fig.7(D).

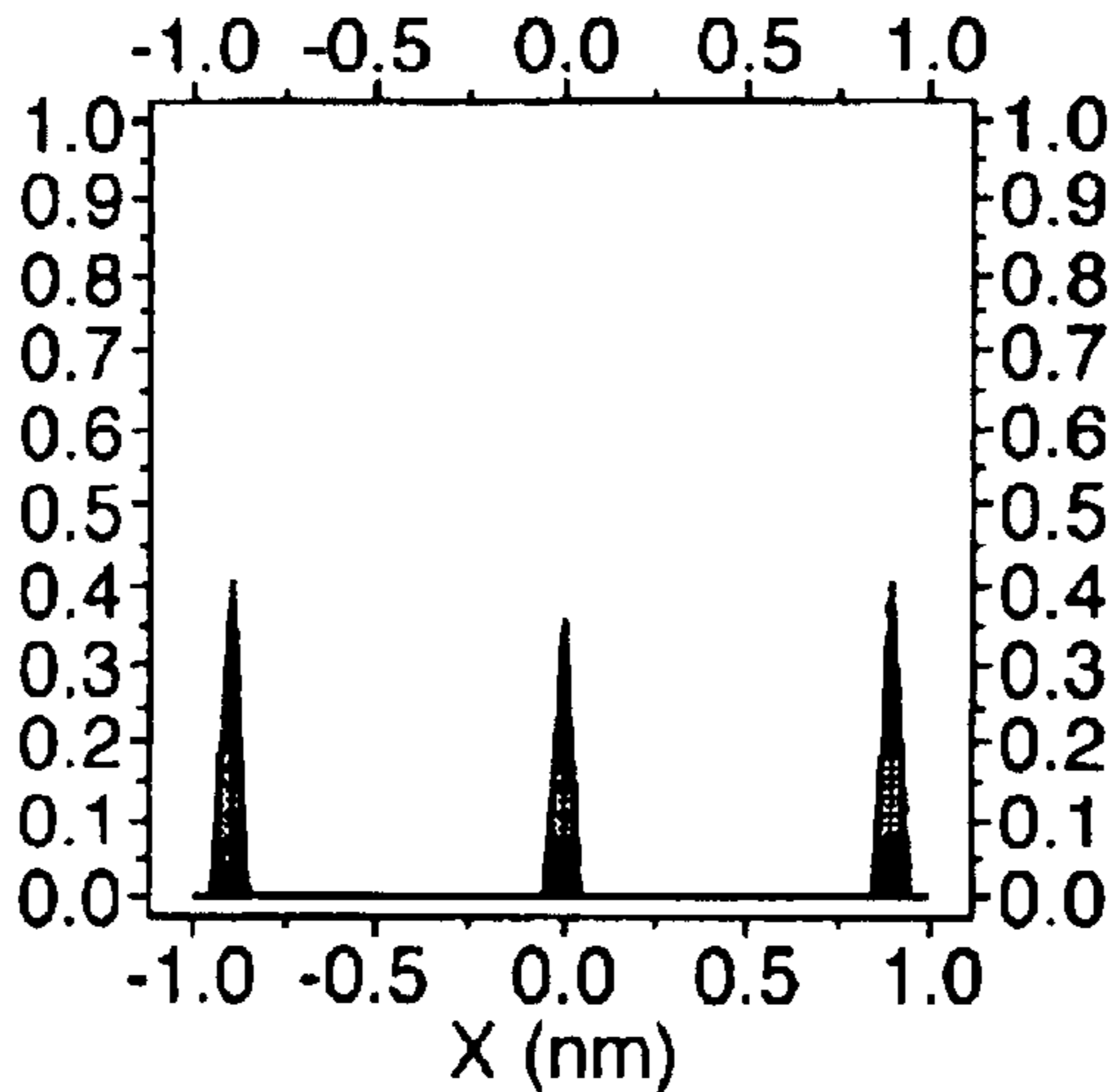

Fig.8(A).

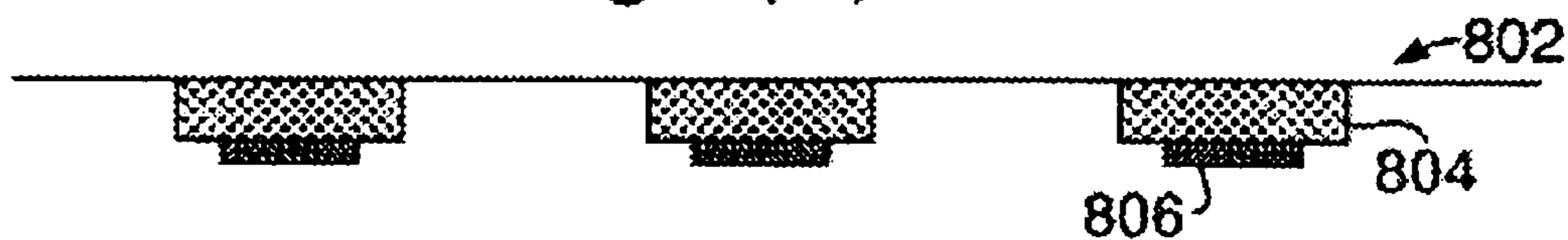

Fig.8(B).

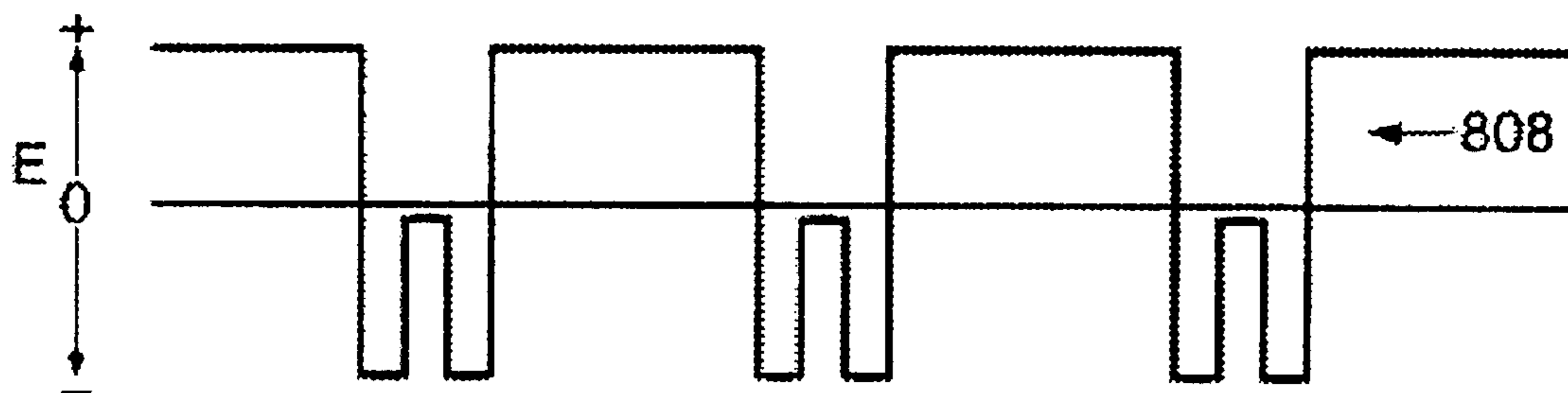

Fig.8(C).

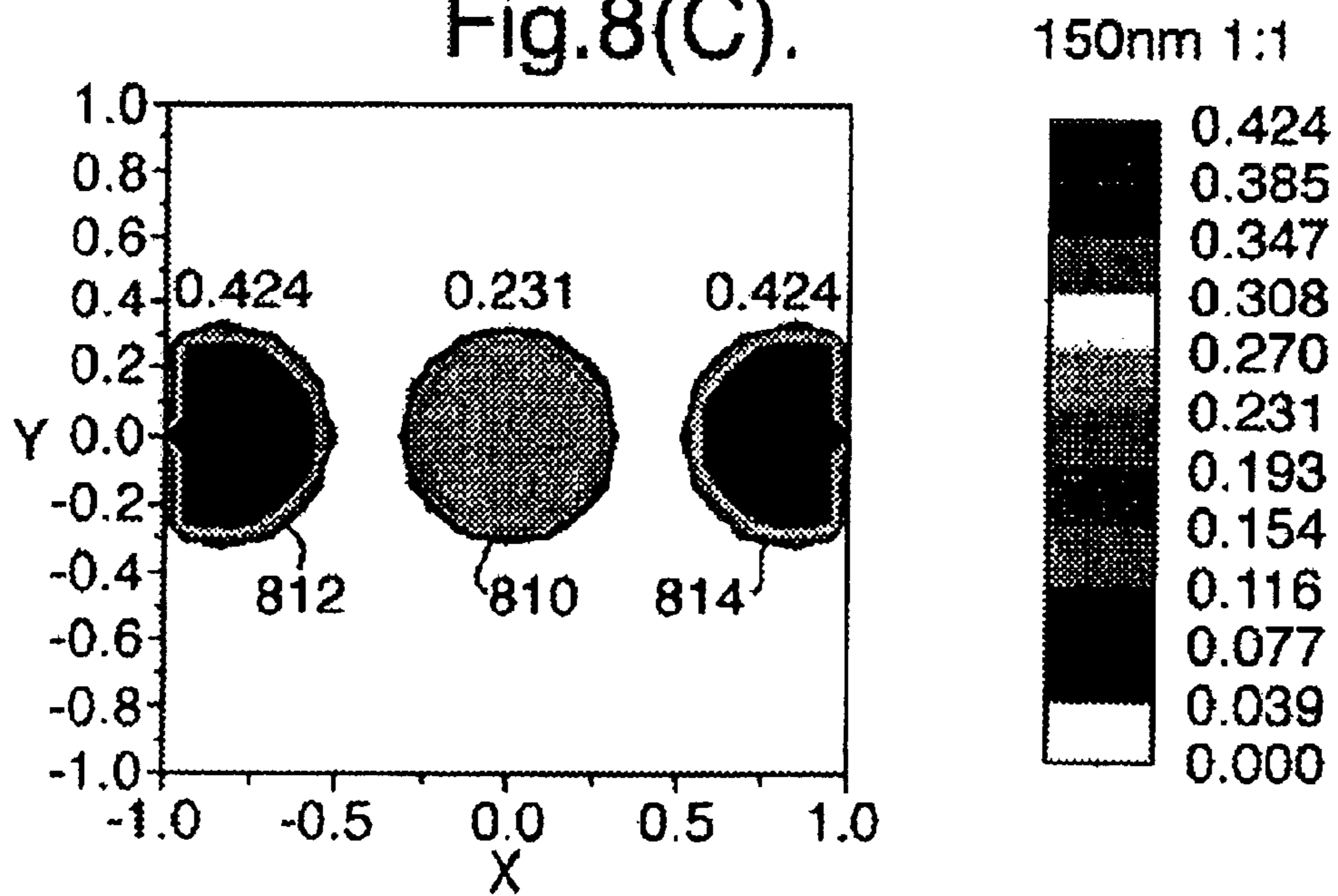

Fig.9(A).

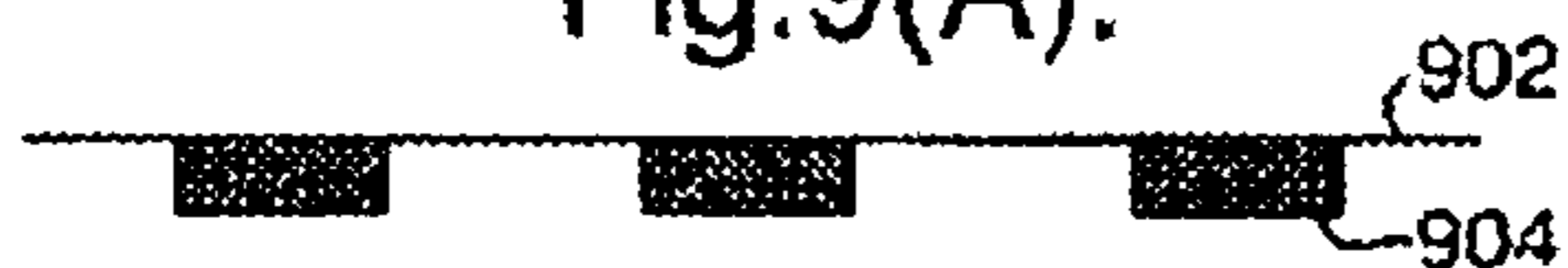

Fig.9(D).



Fig.9(B).

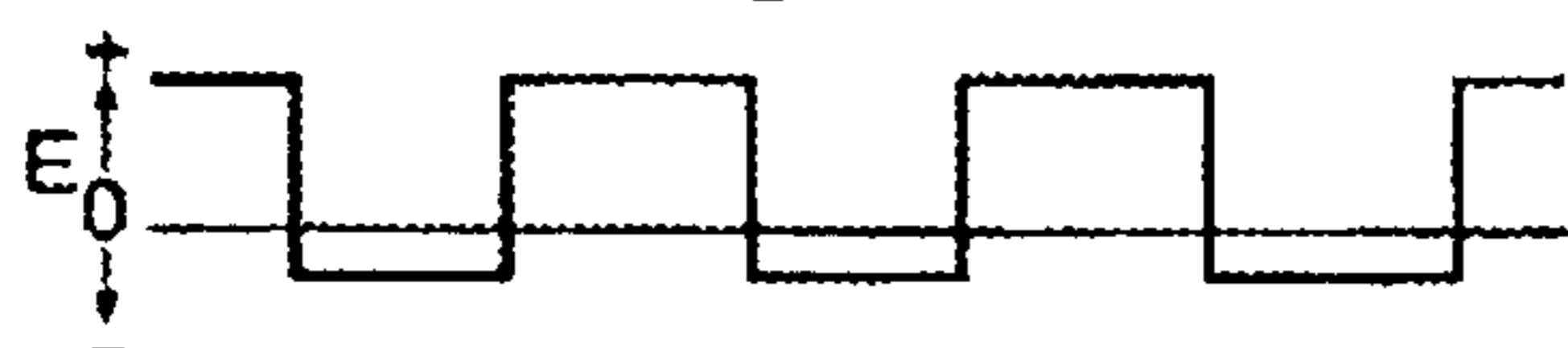

Fig.9(E).

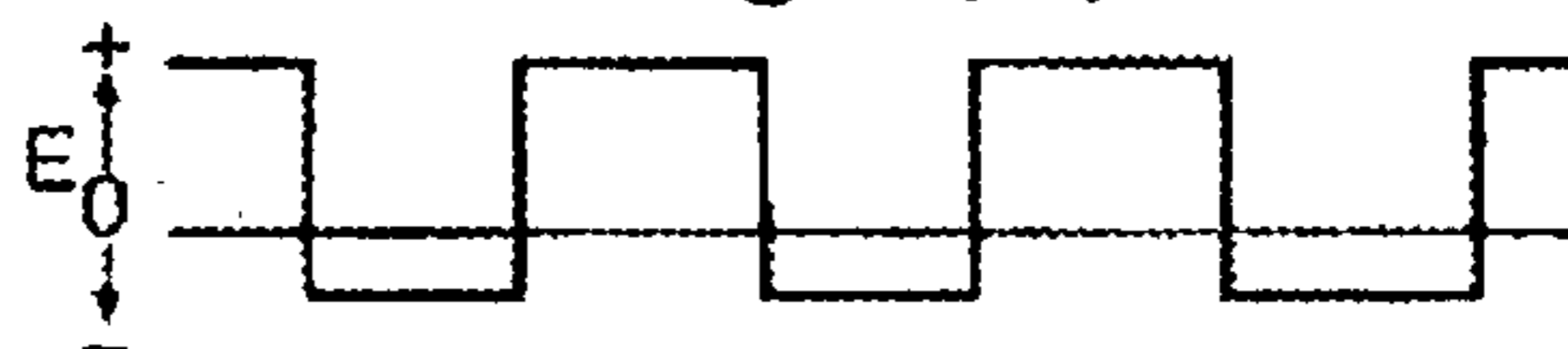

Fig.9(C).

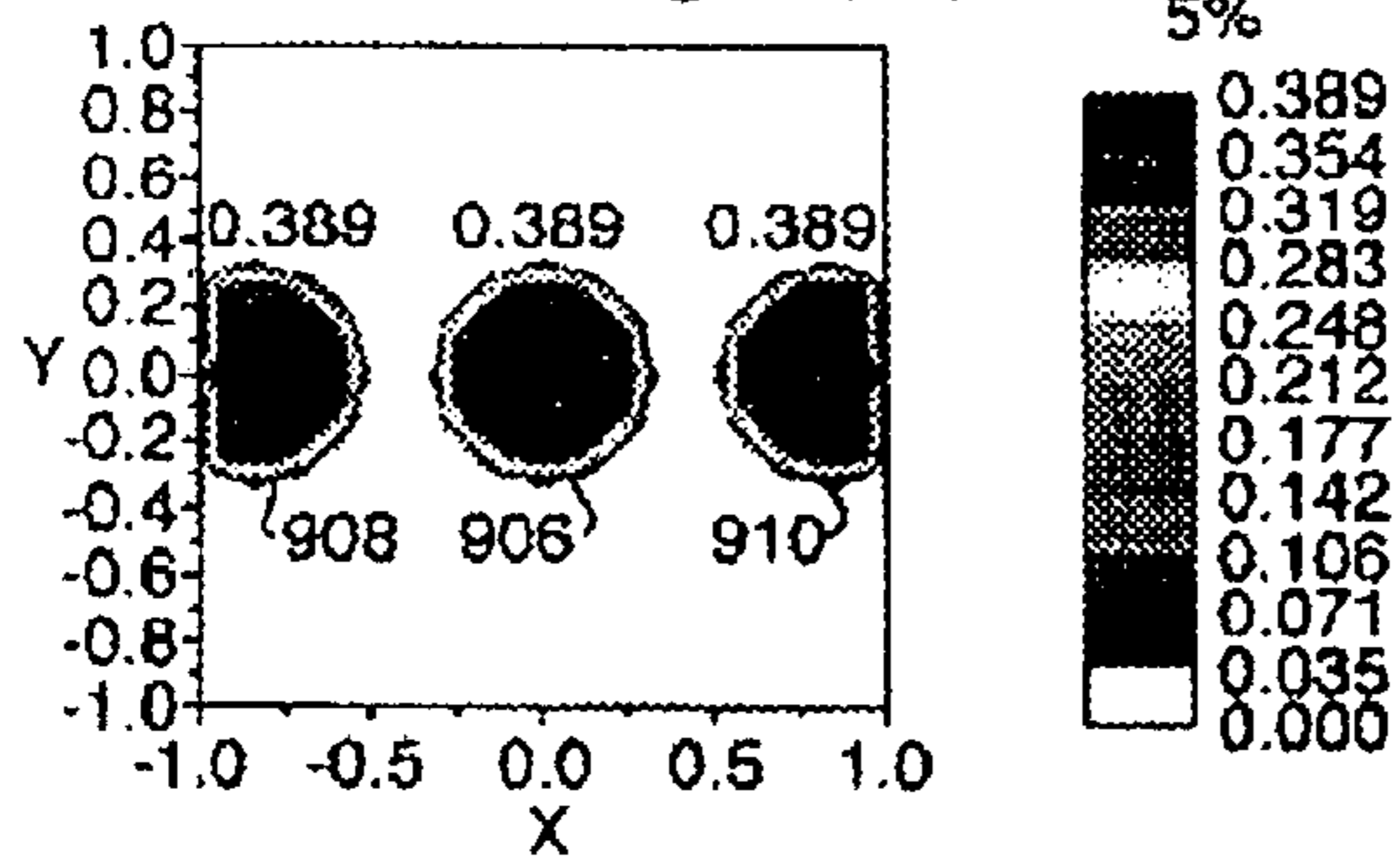

Fig.9(F).

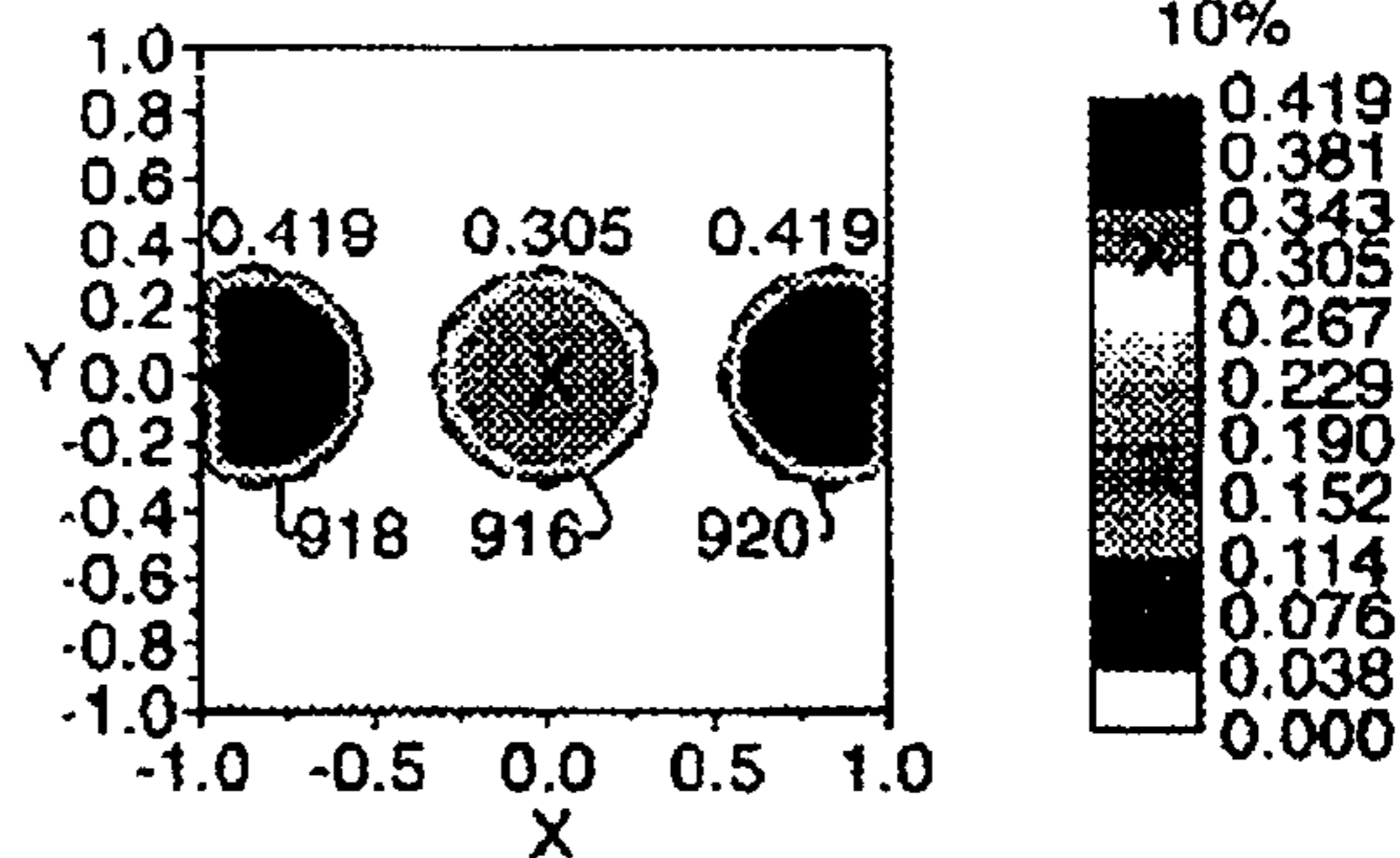

Fig. 10(A).

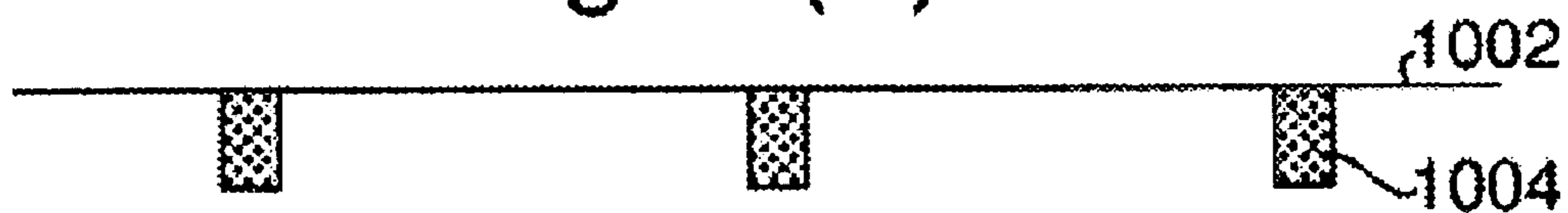

Fig. 10(B).

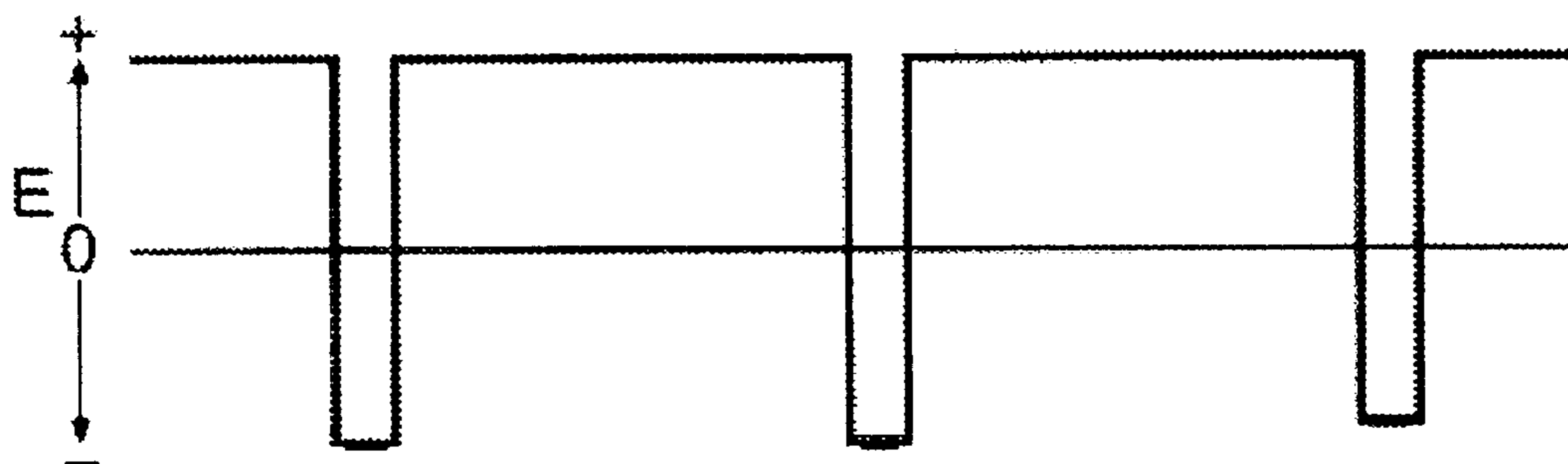

Fig. 10(C).

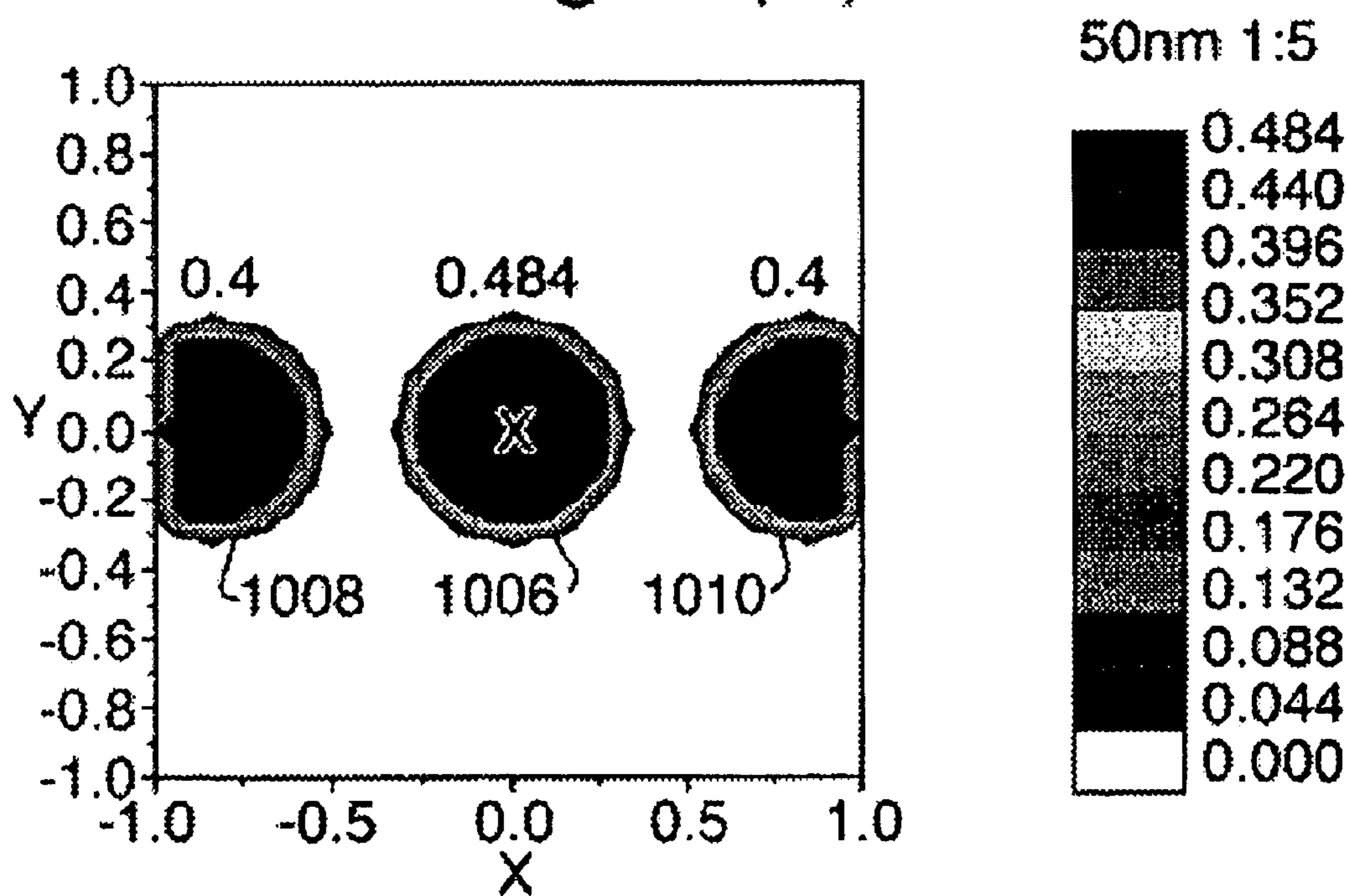

Fig. 11(A).

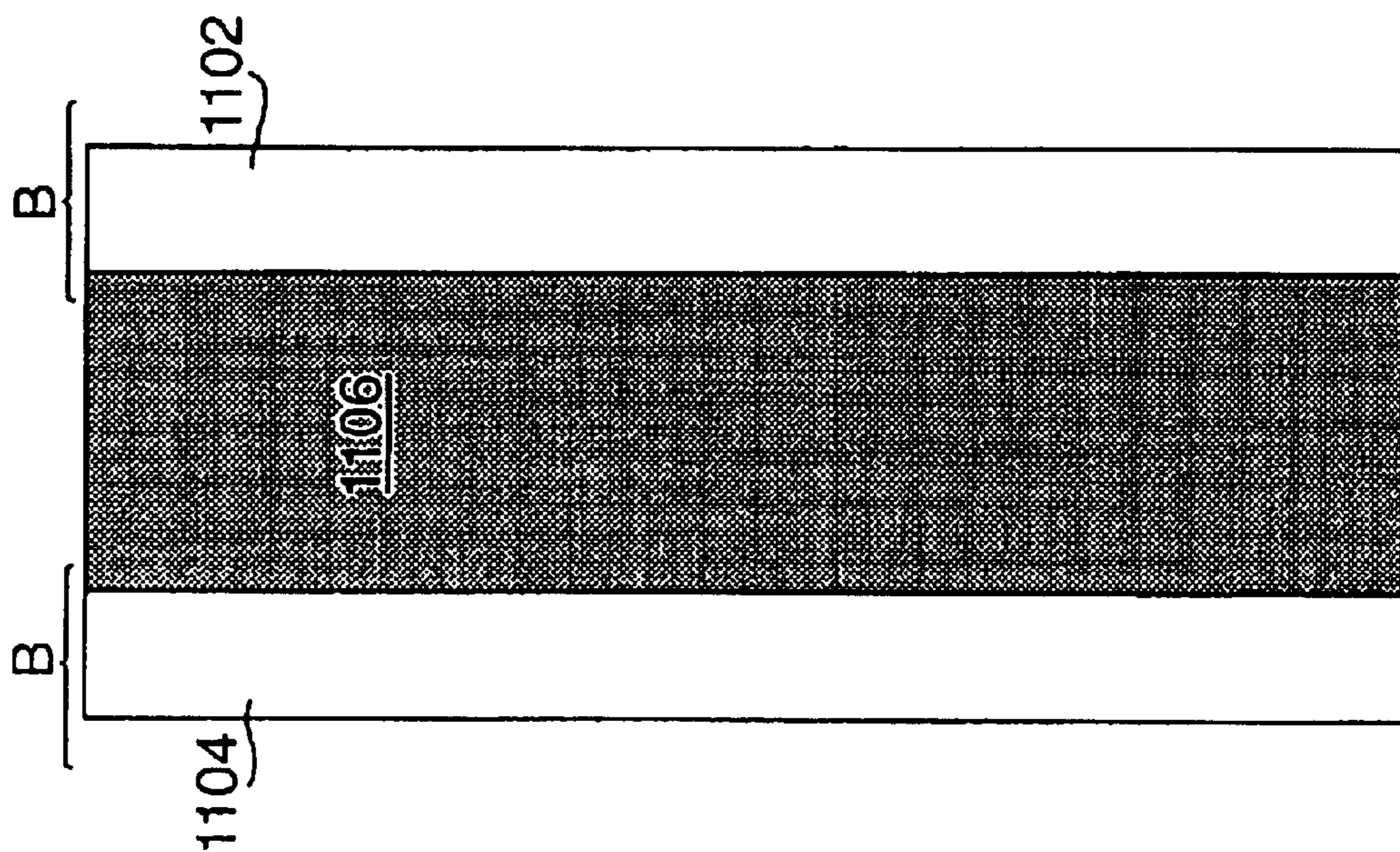

Fig. 11(B).

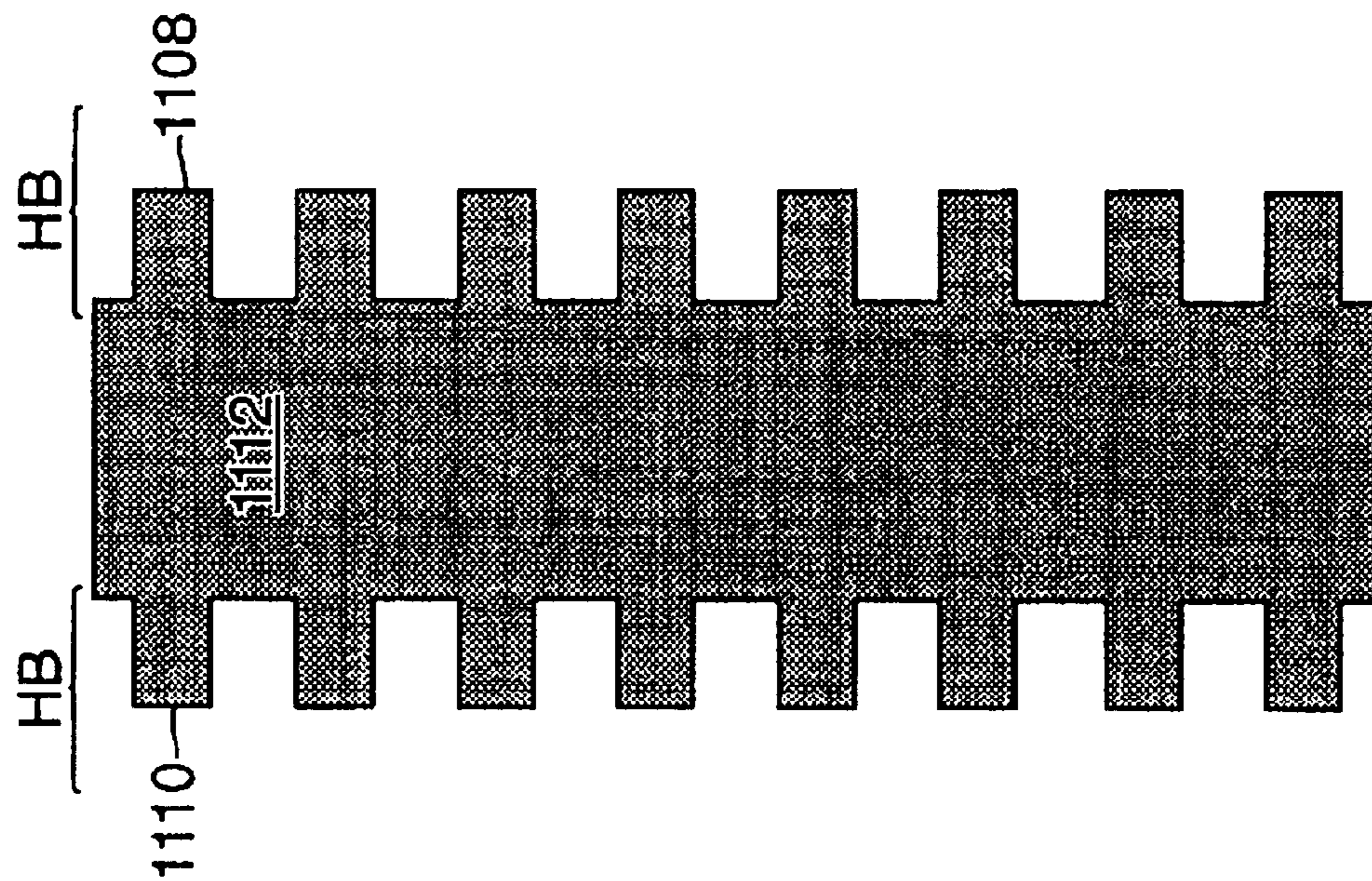

Fig. 12.

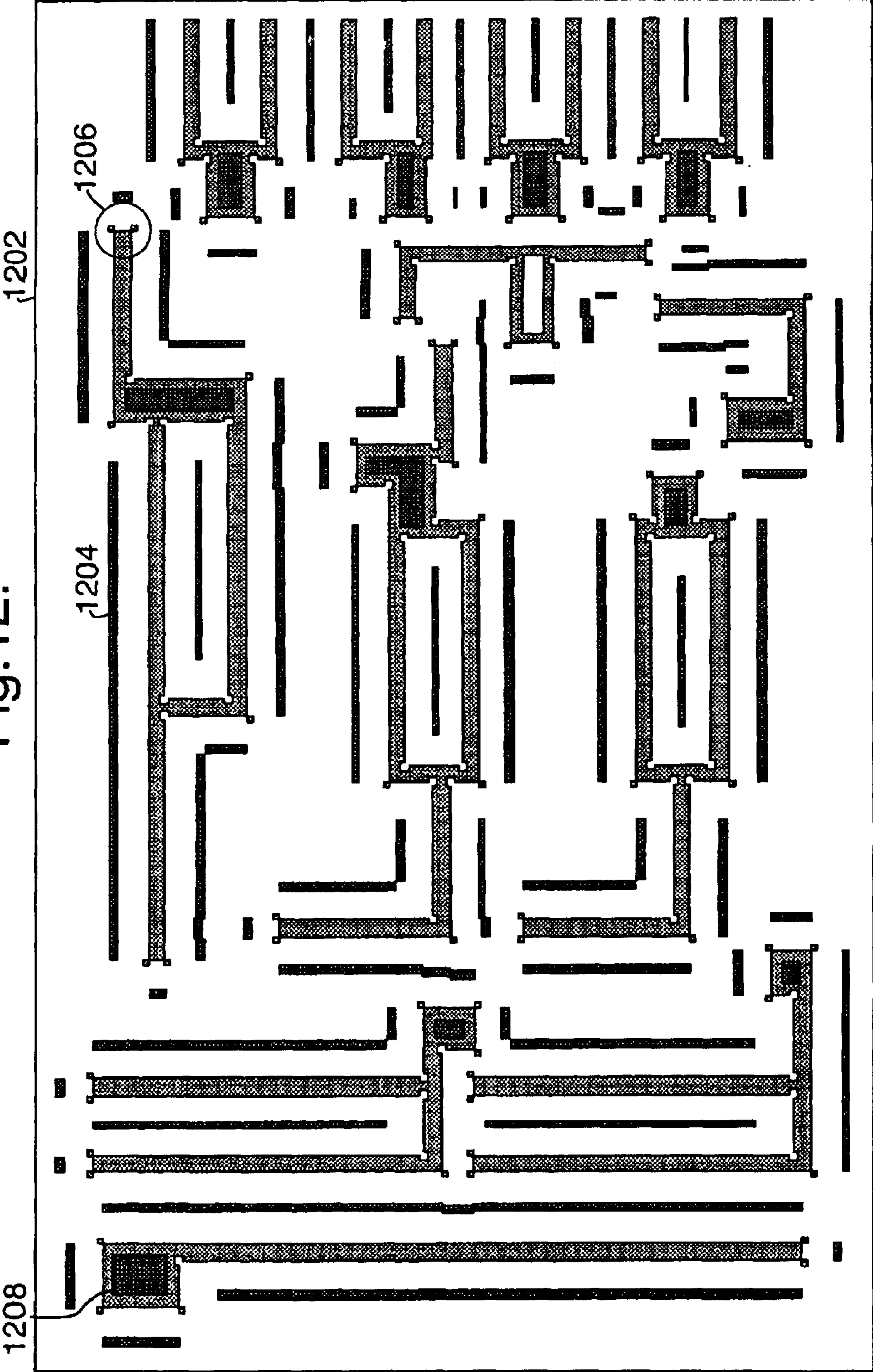

Fig.13(A).

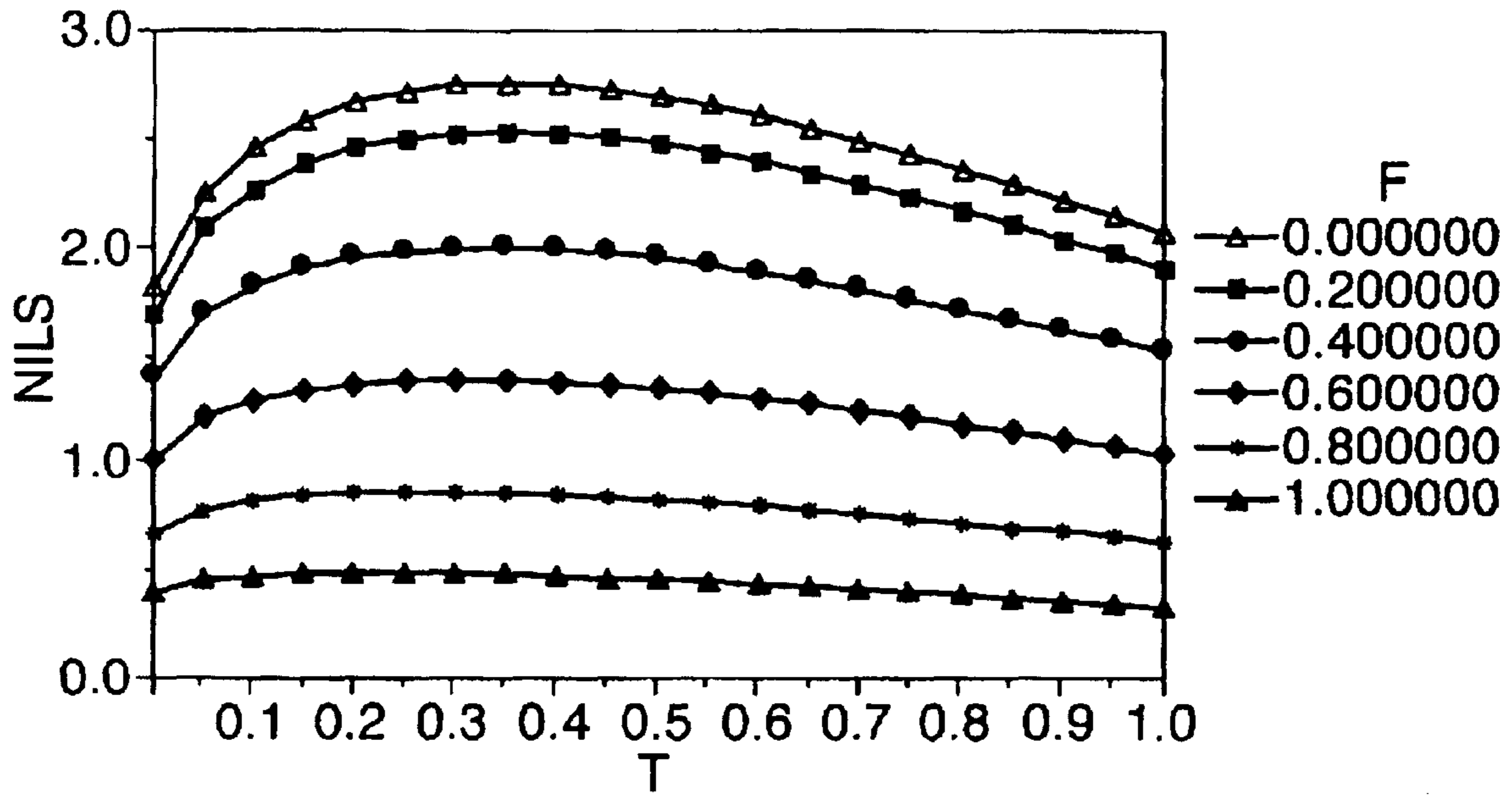

Fig.13(B).

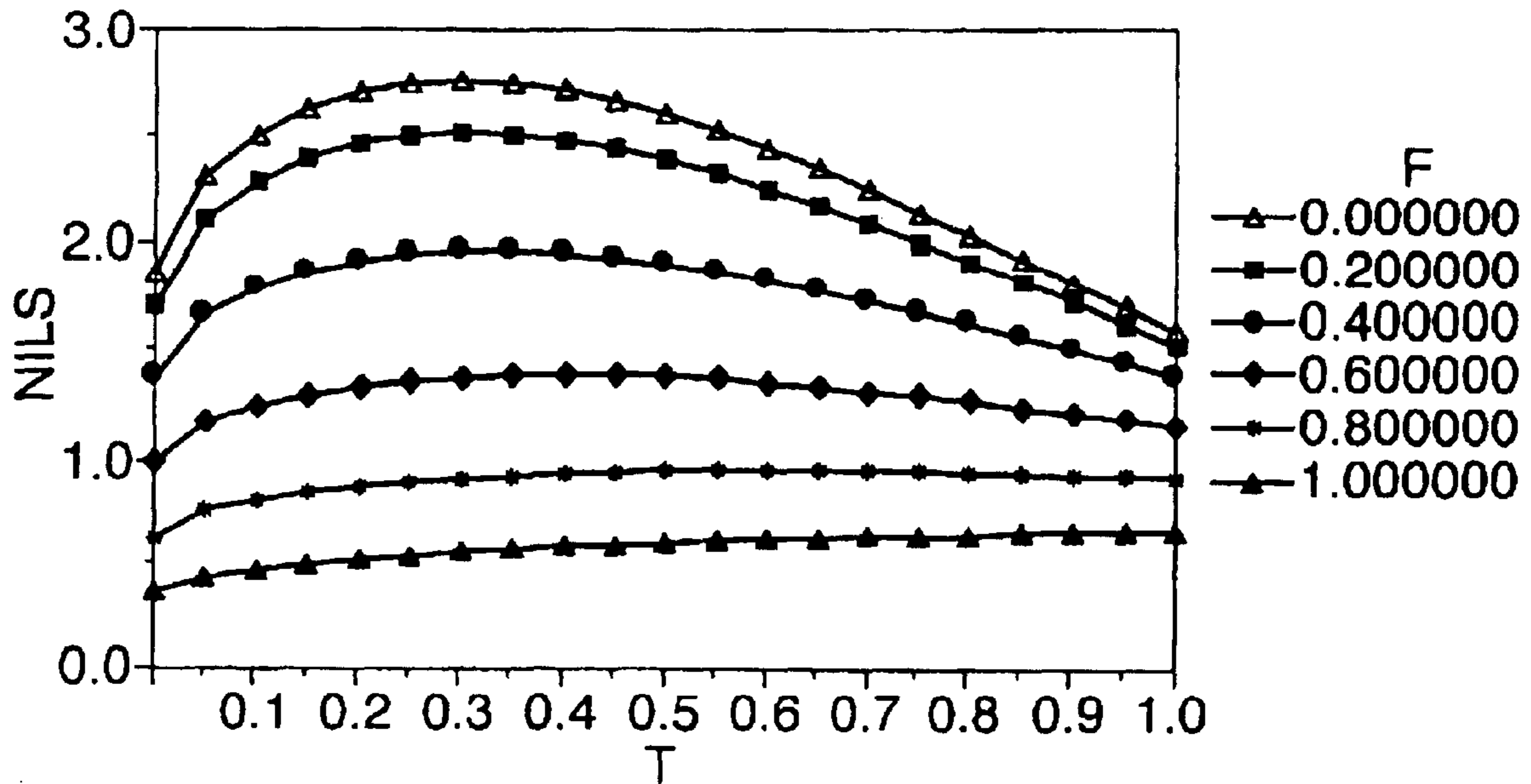

Fig.14(A).

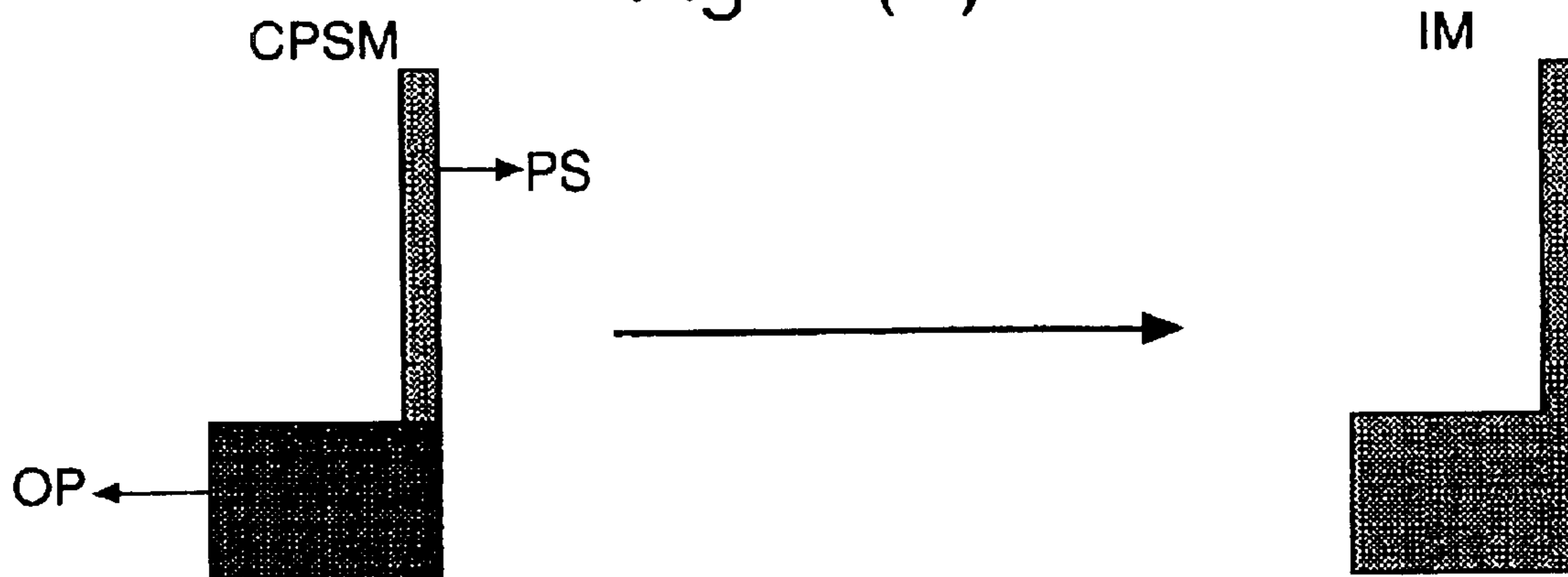

Fig.14(B).

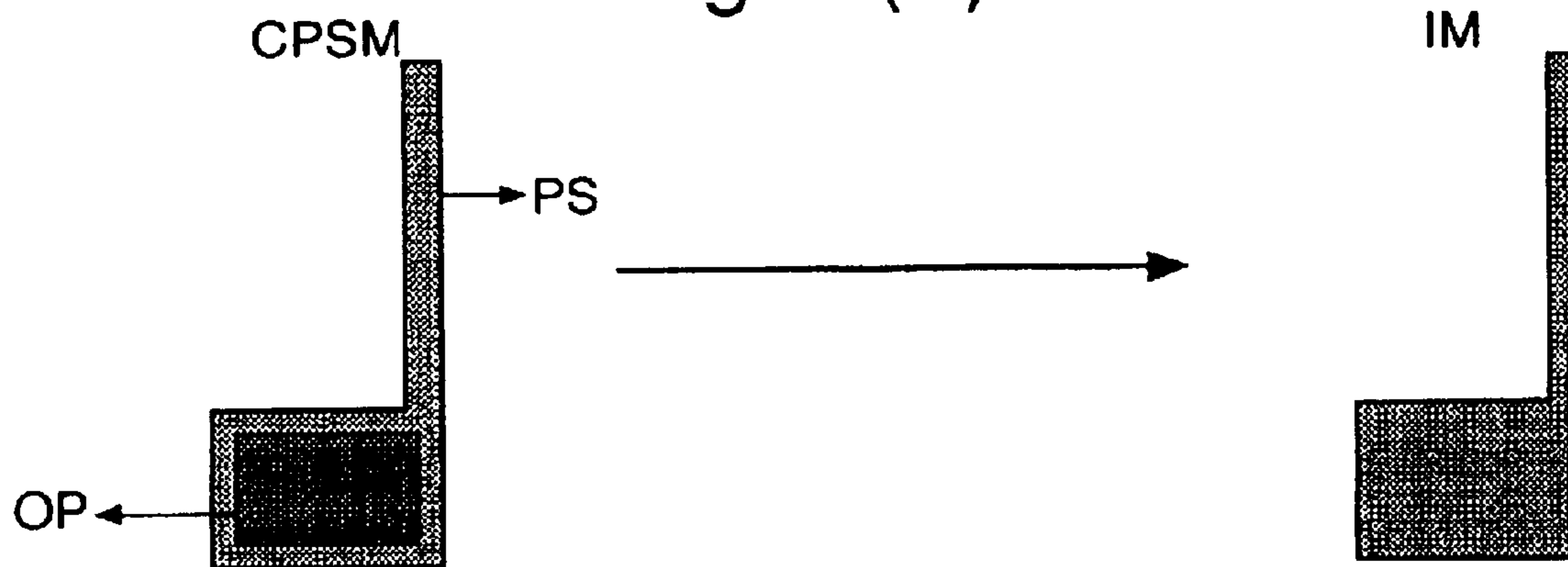

Fig.15.

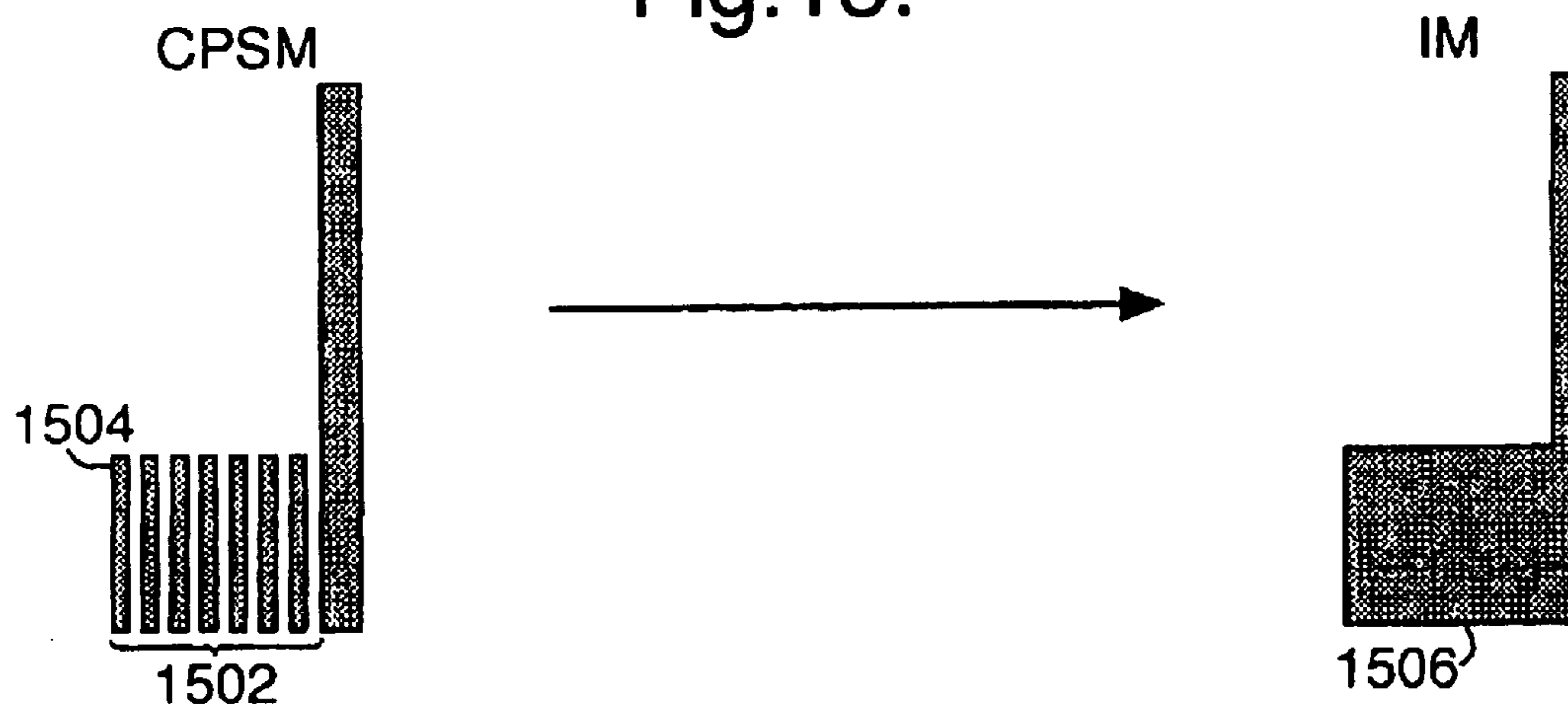

Fig. 16(A).

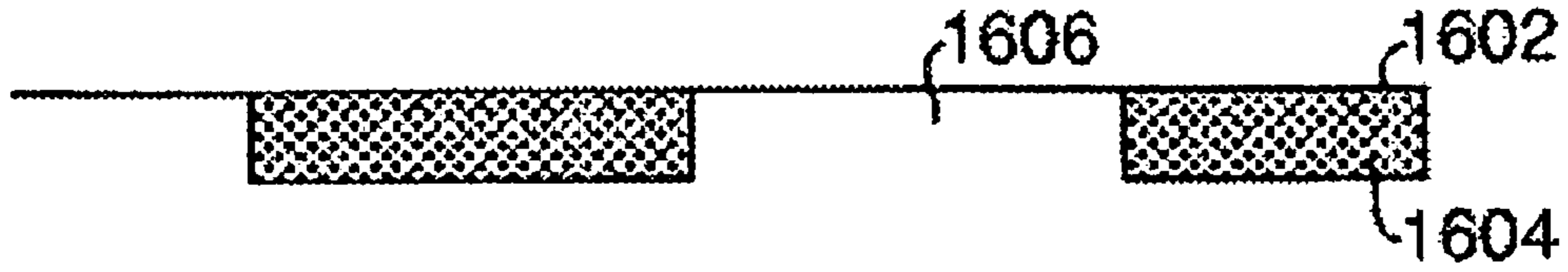

Fig. 16(B).

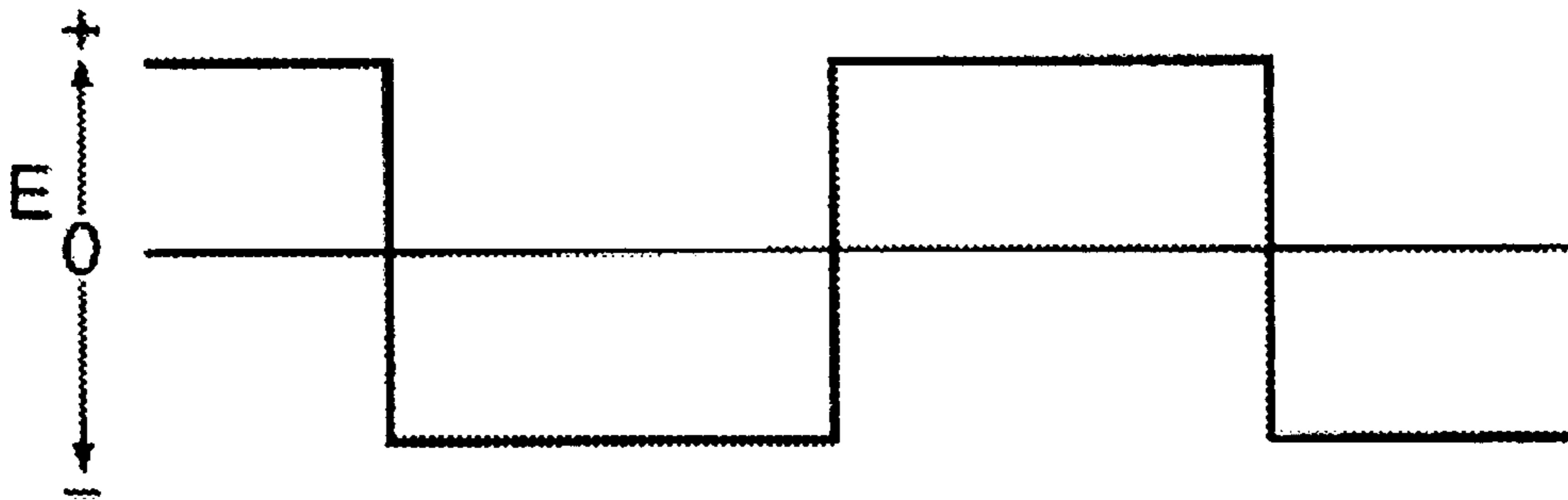
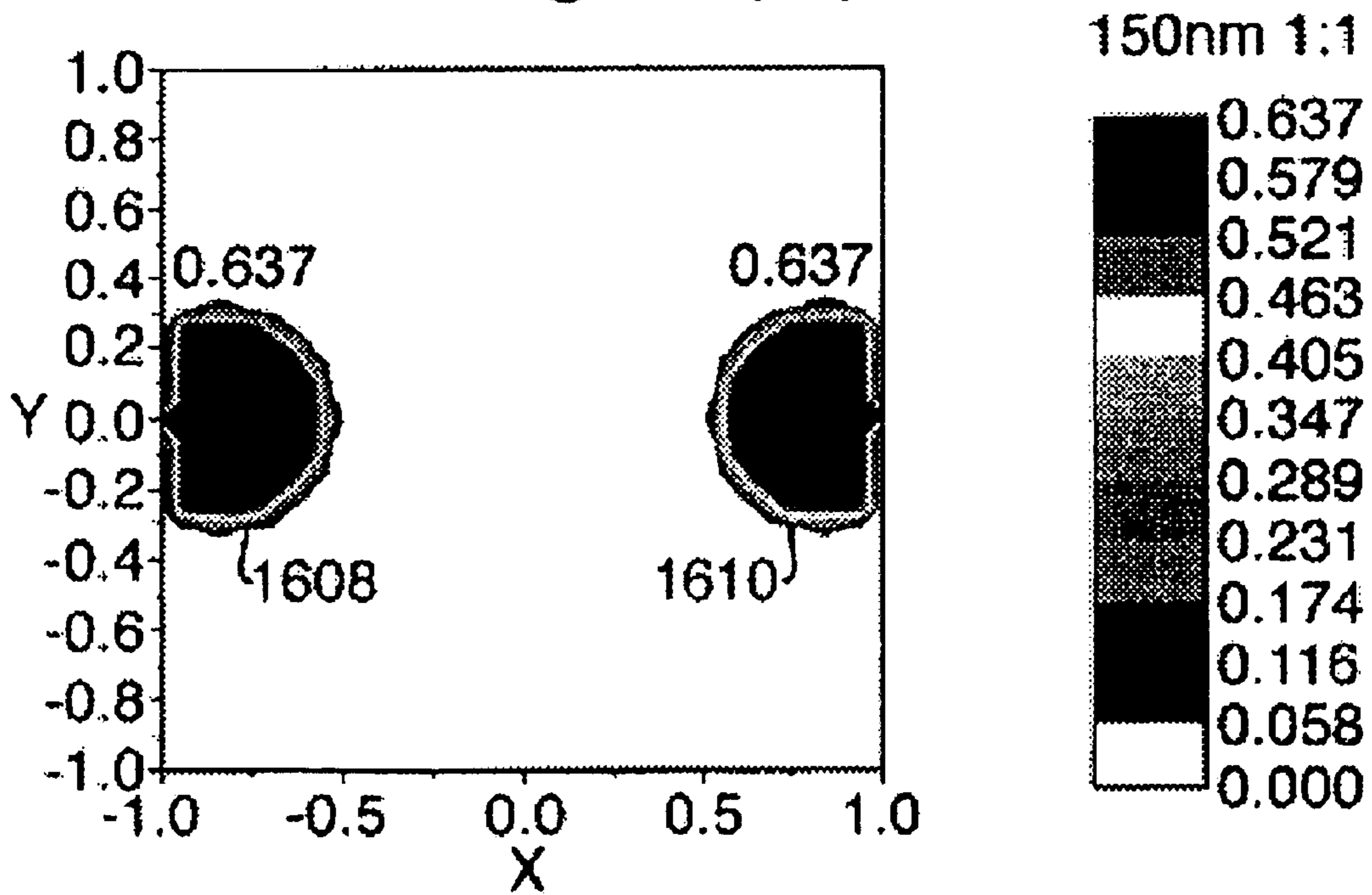
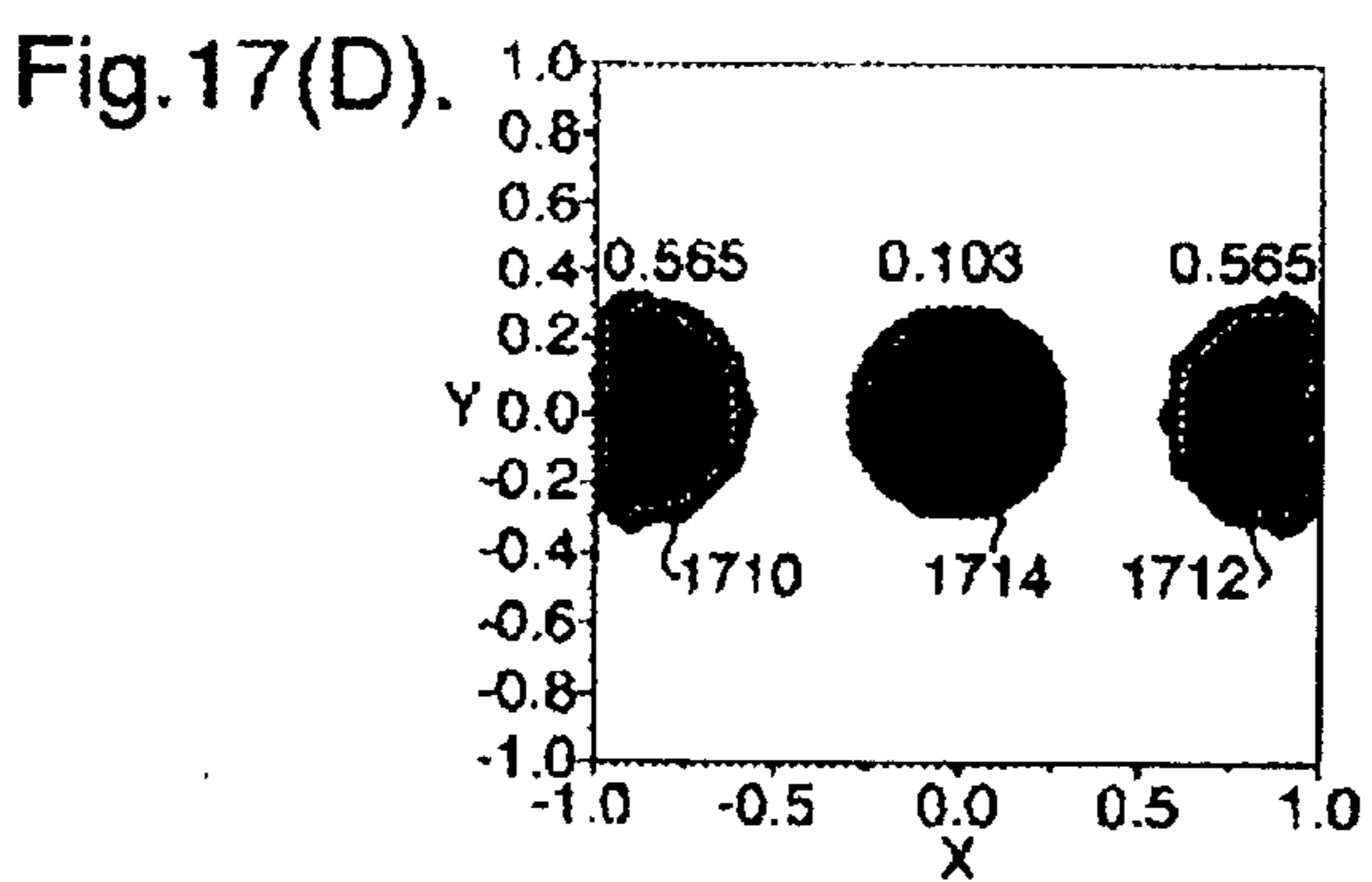
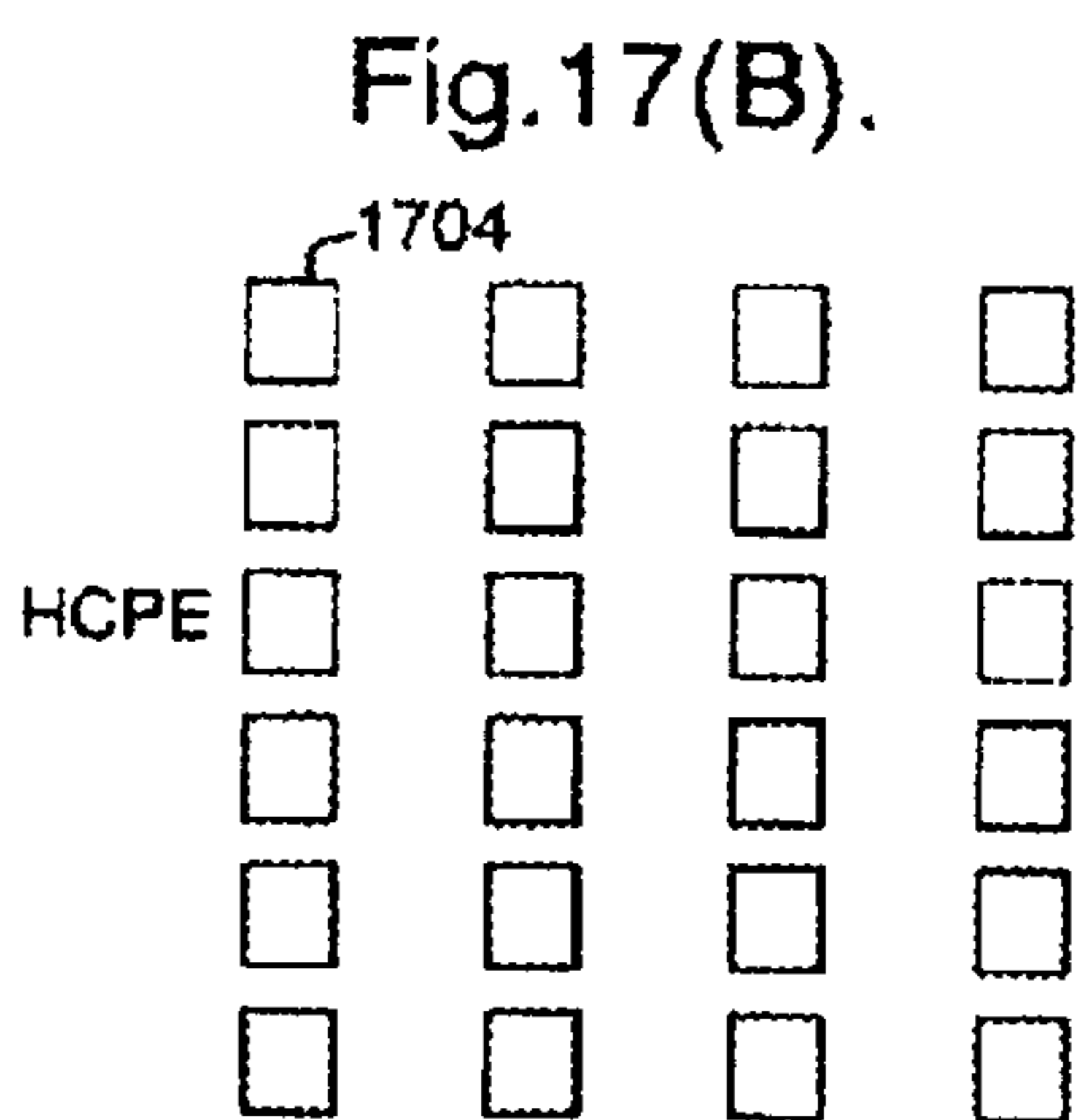
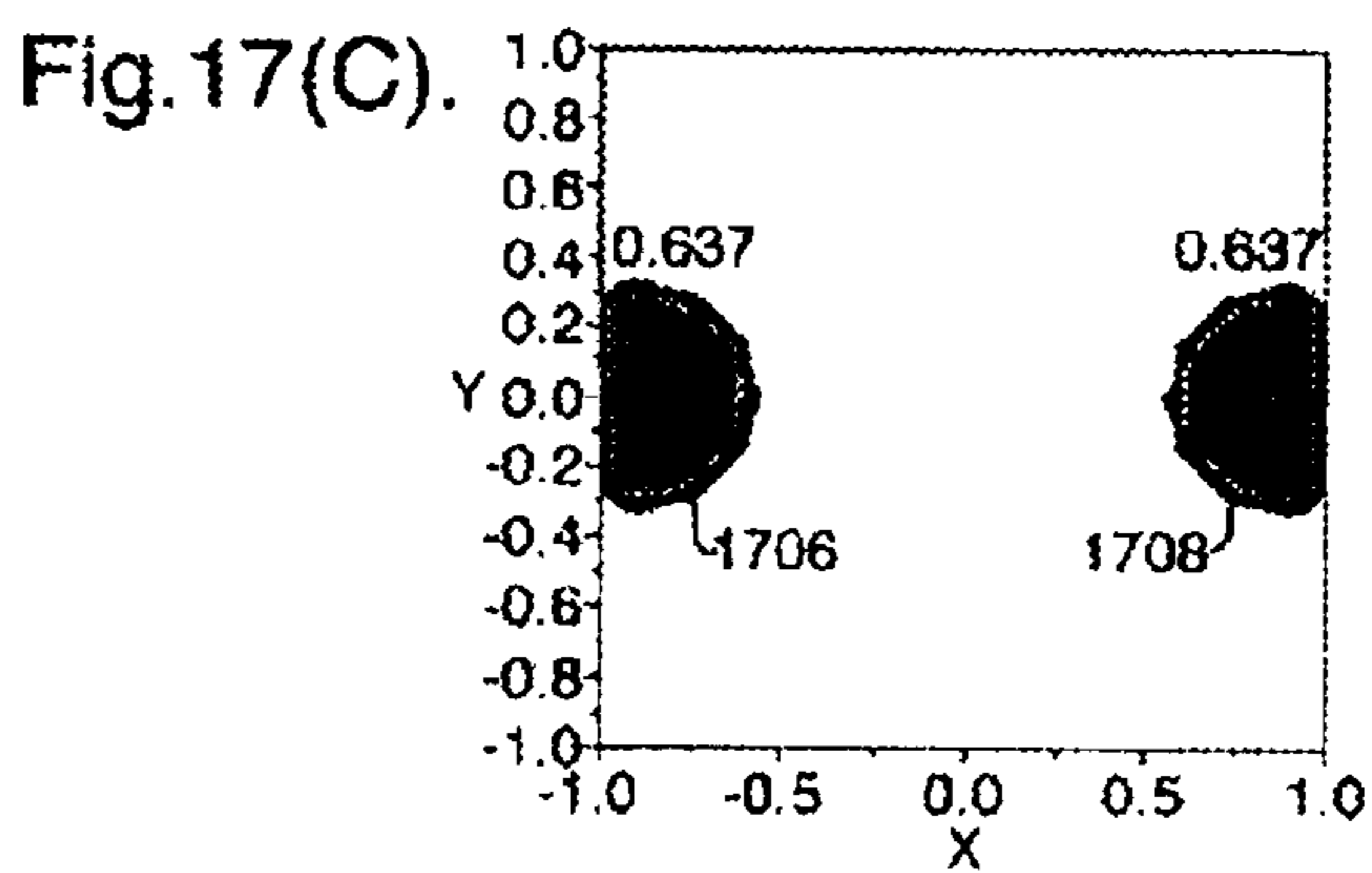
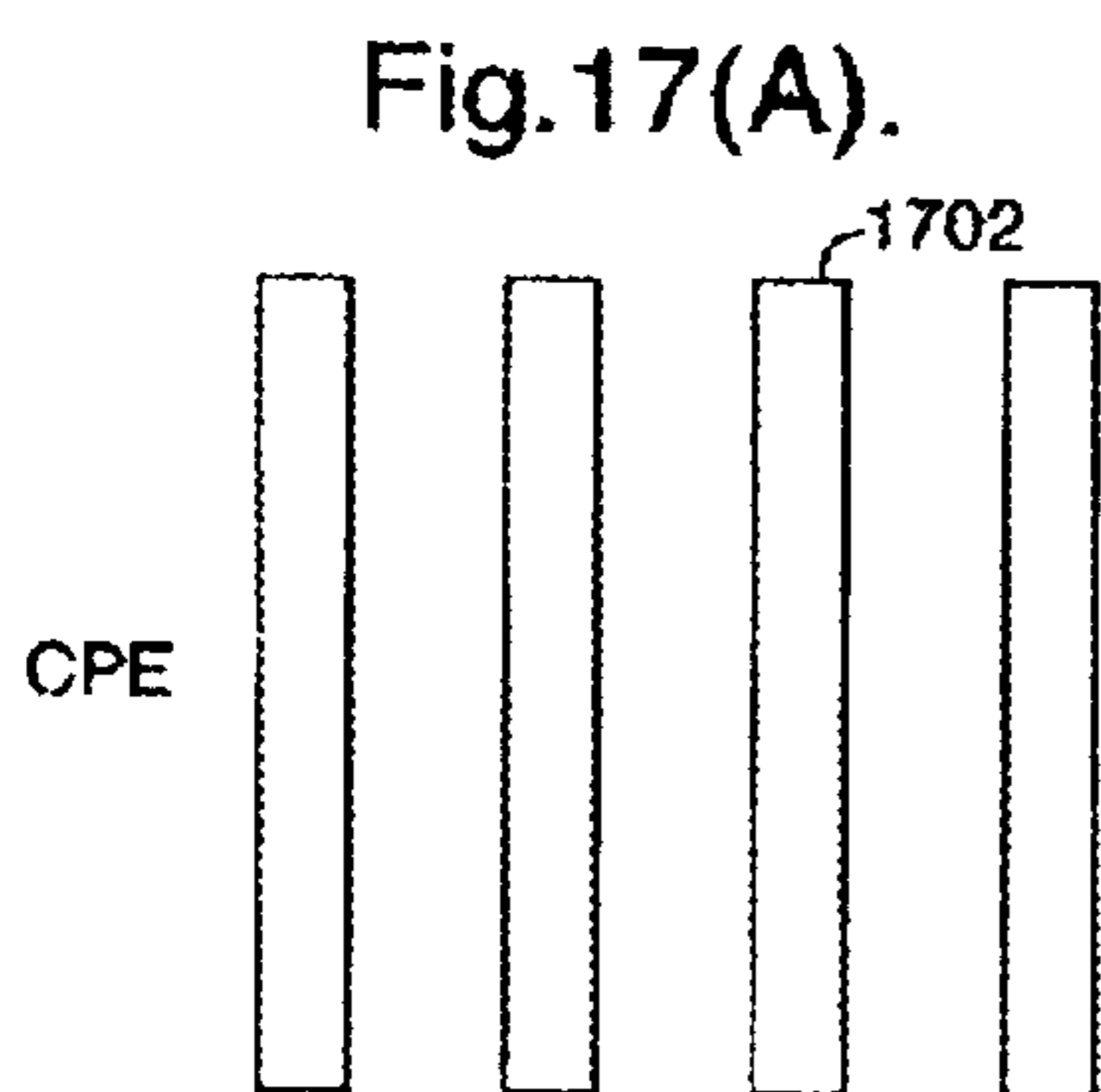
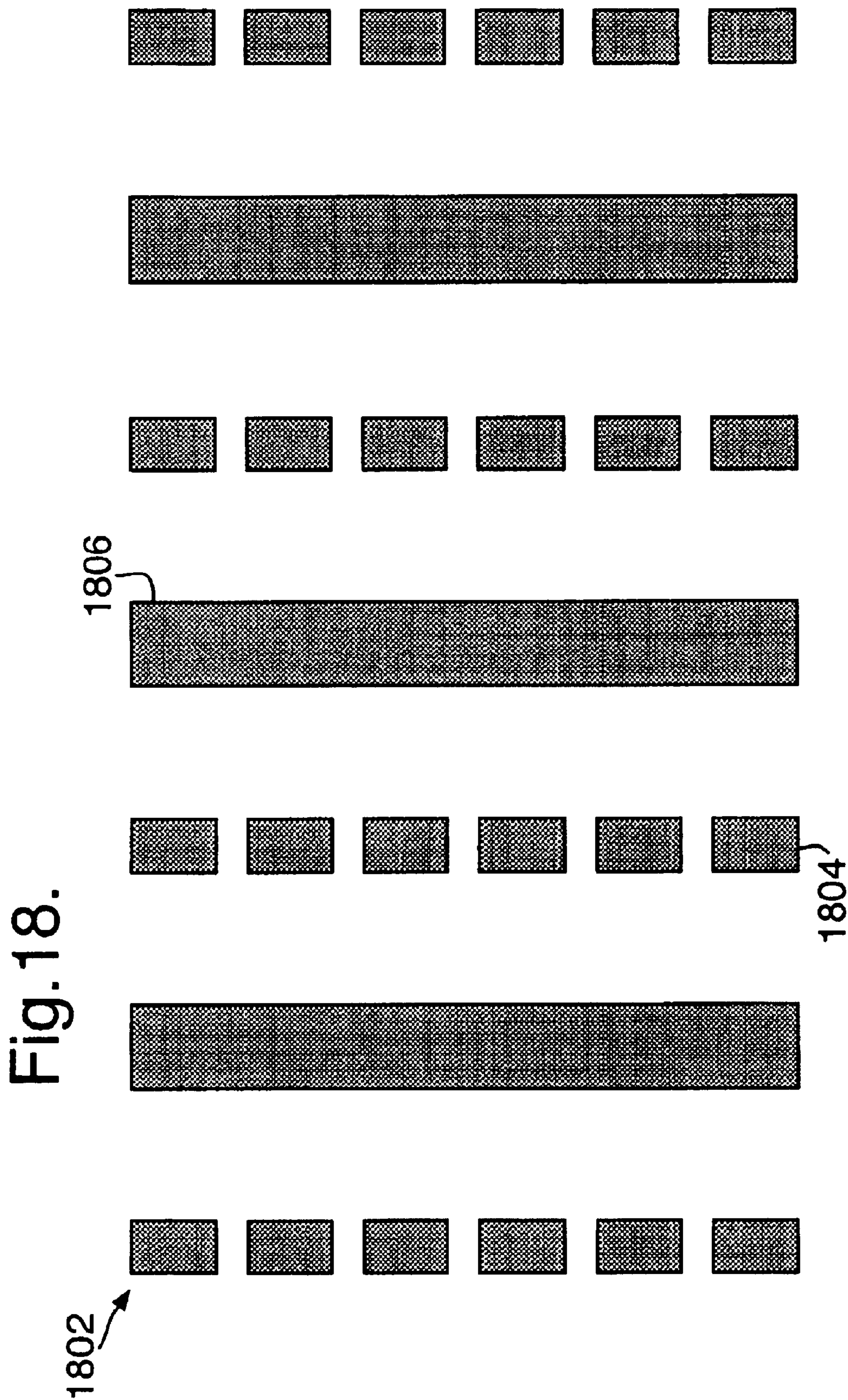

Fig. 16(C).







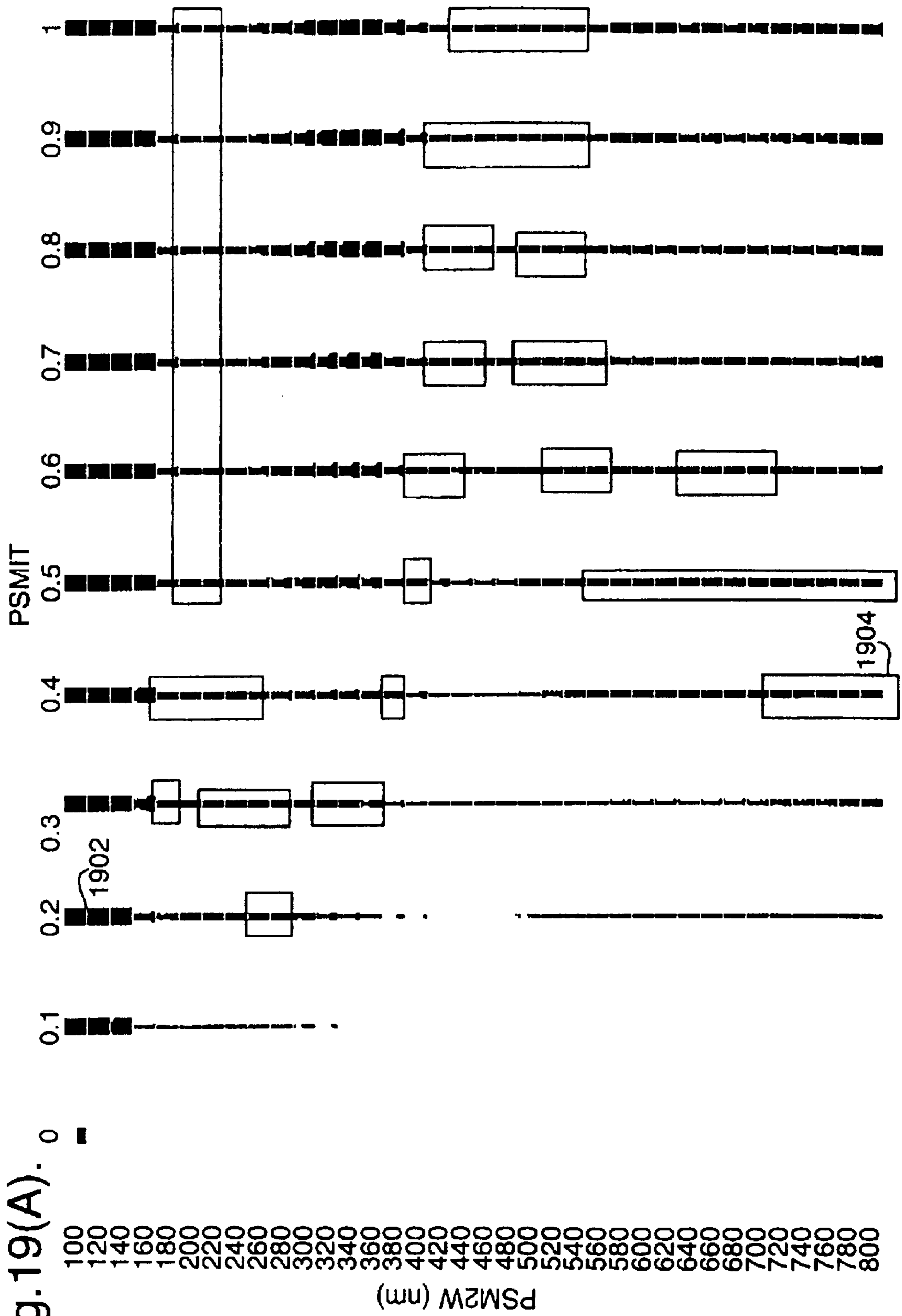

Fig. 19(A)

Fig. 19(B).

22mJ/-0.15 μm

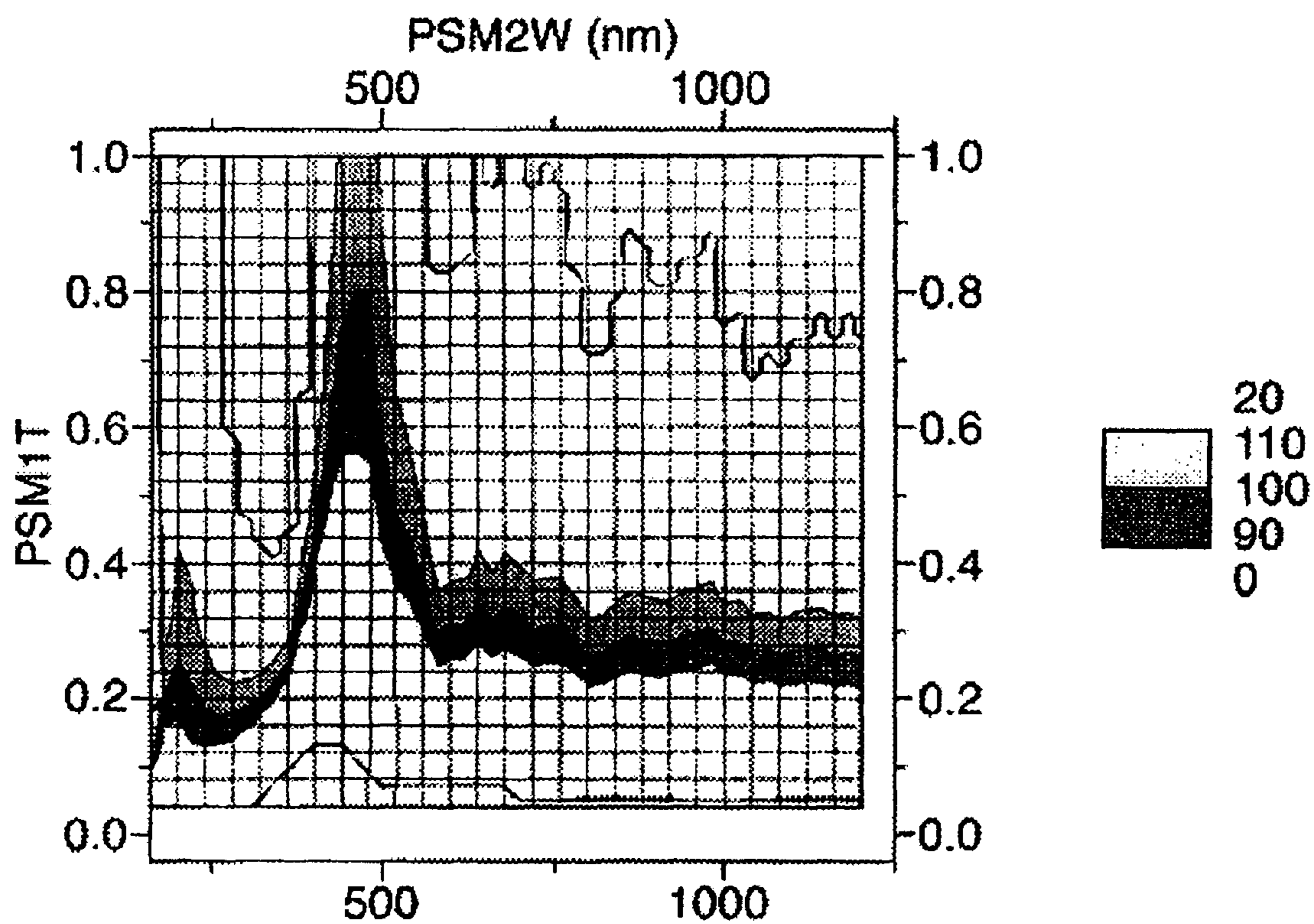

Fig.19(C).

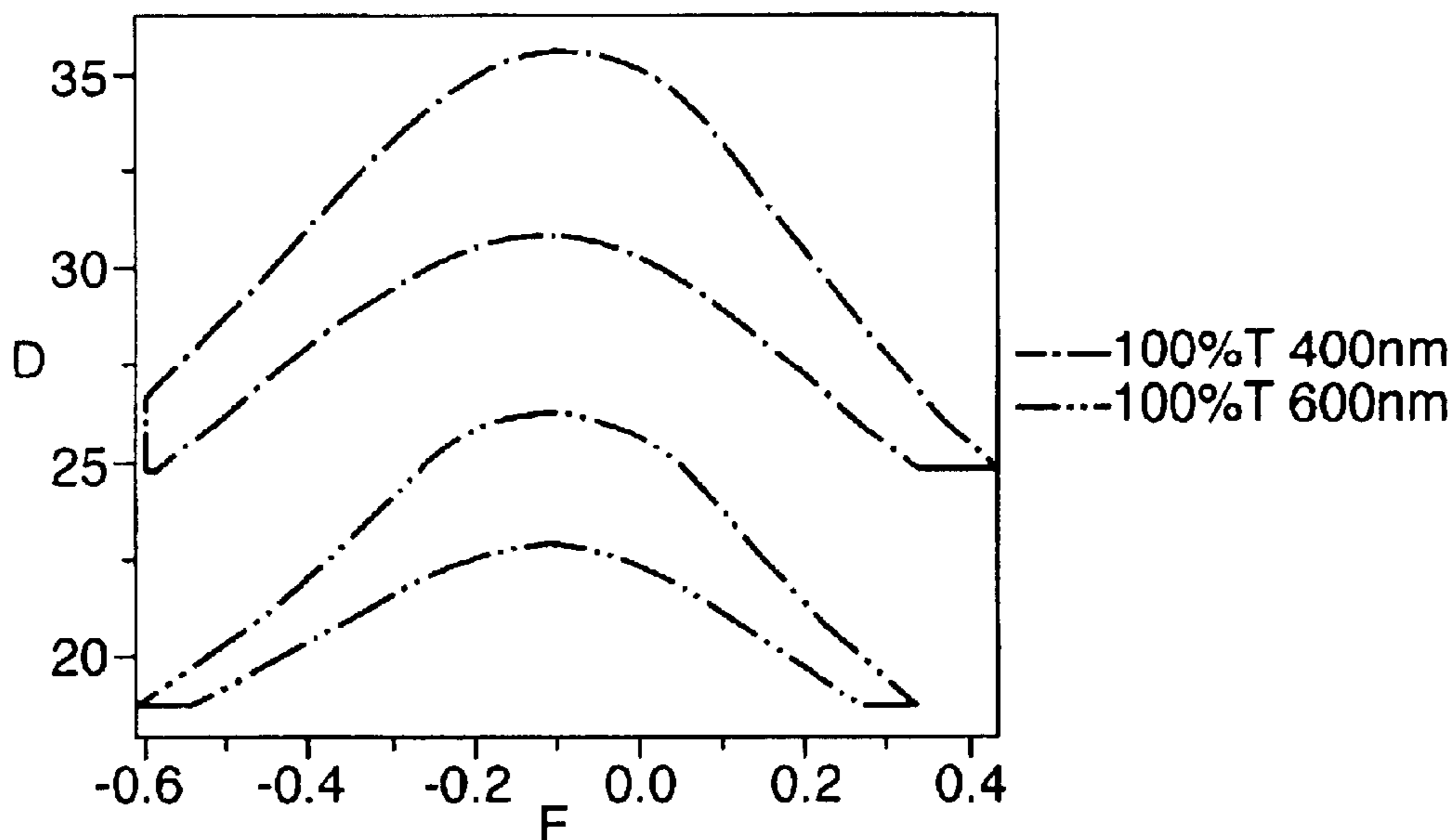

Fig.19(D).

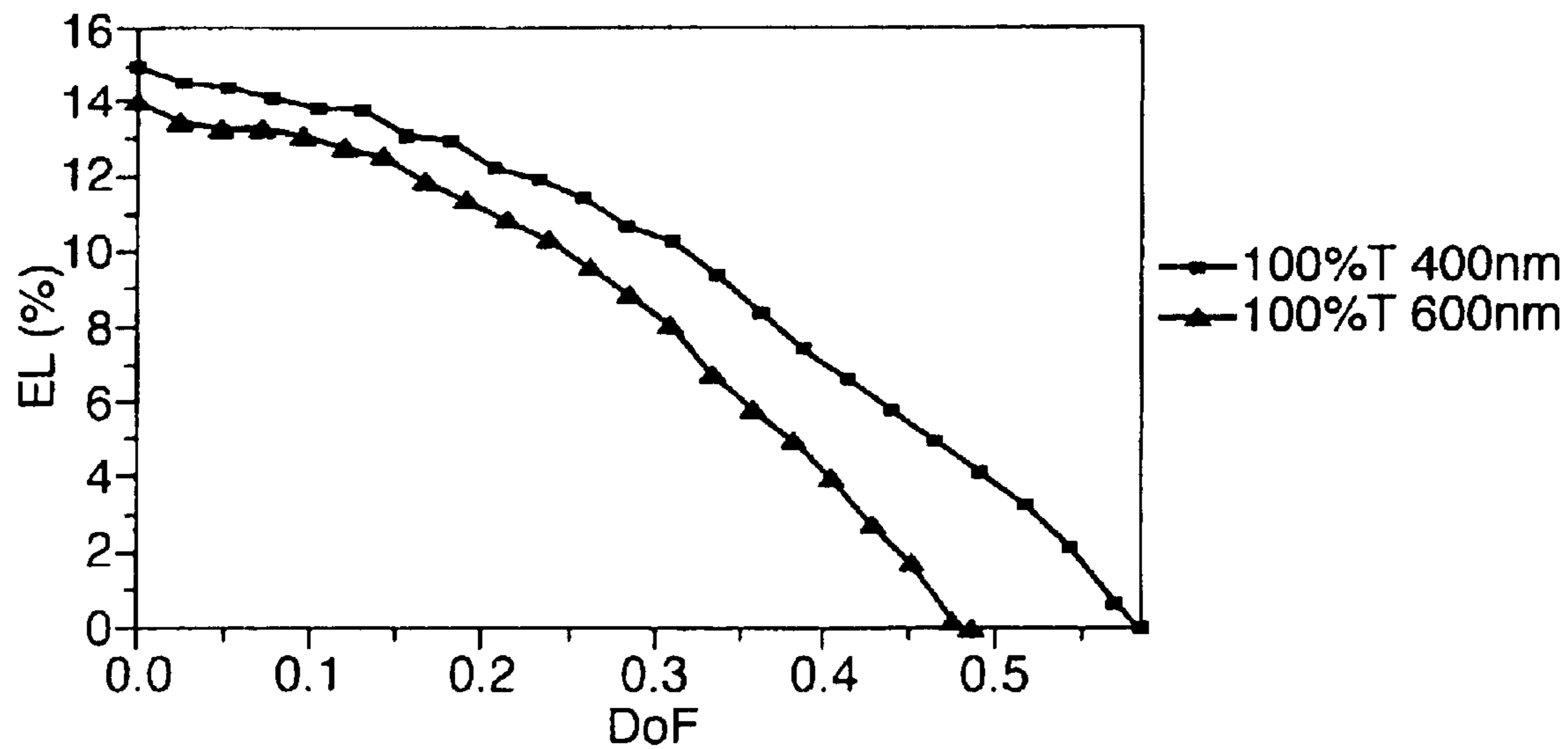

Fig.20(A).

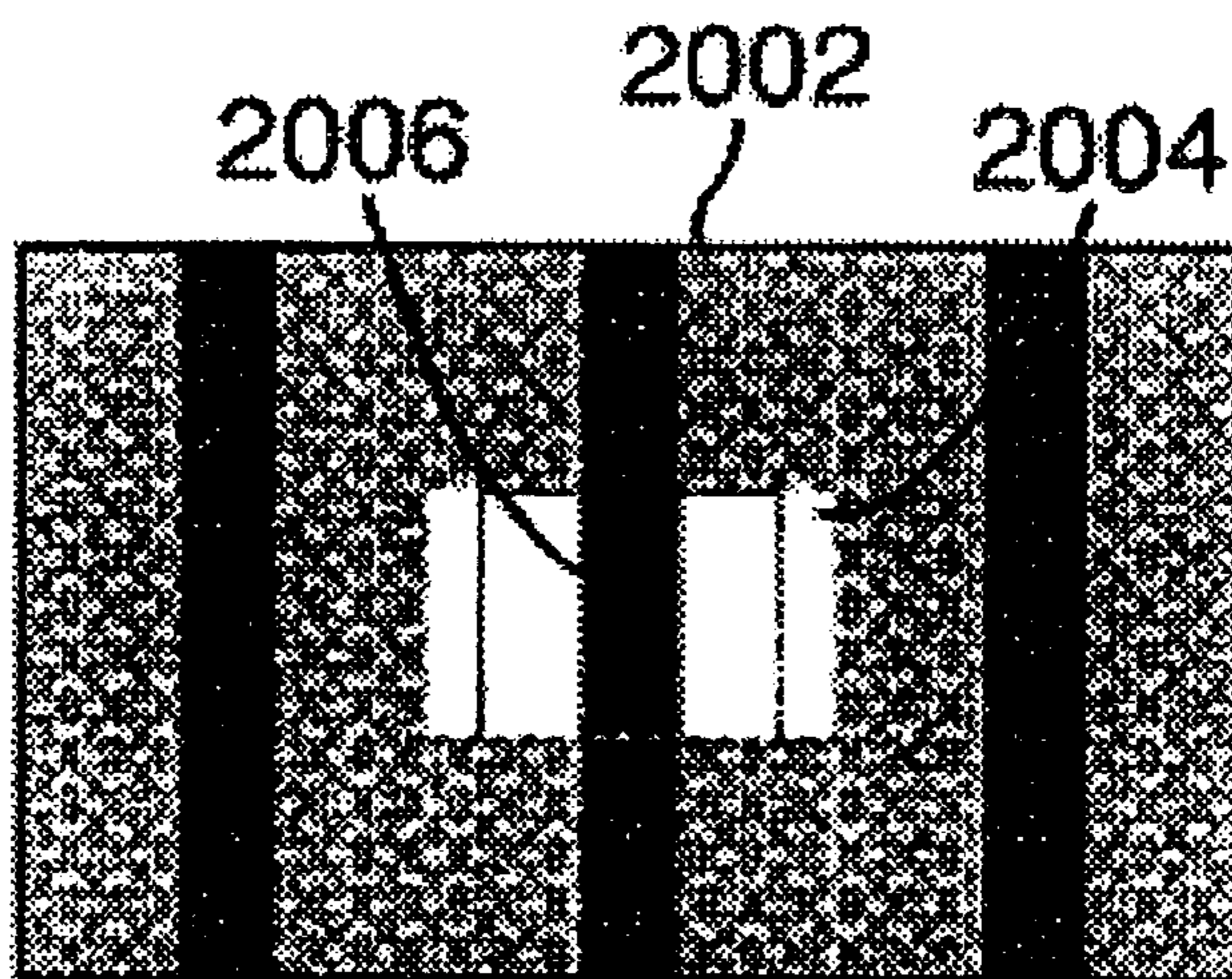

Fig.20(B).

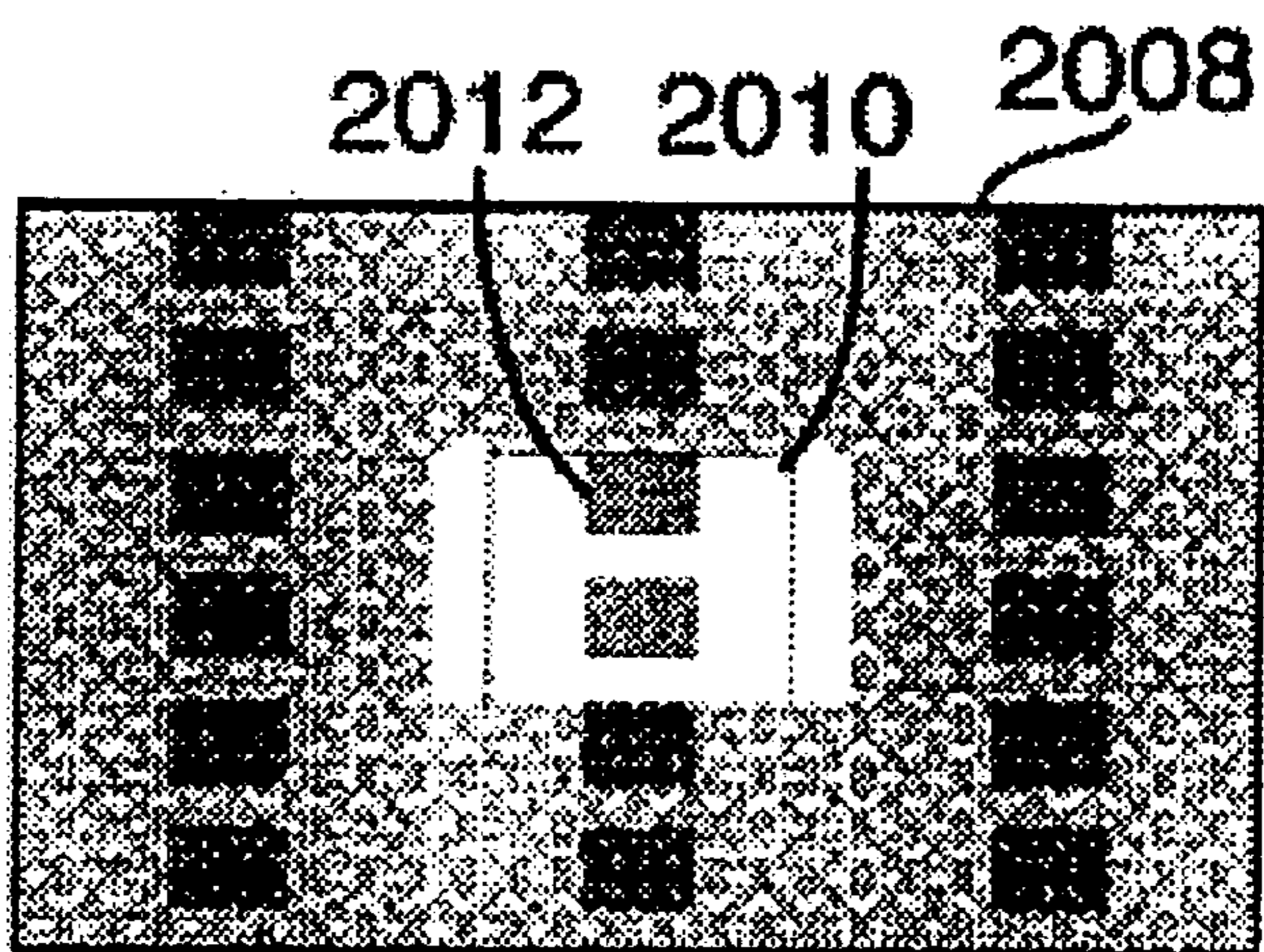

Fig.20(C).

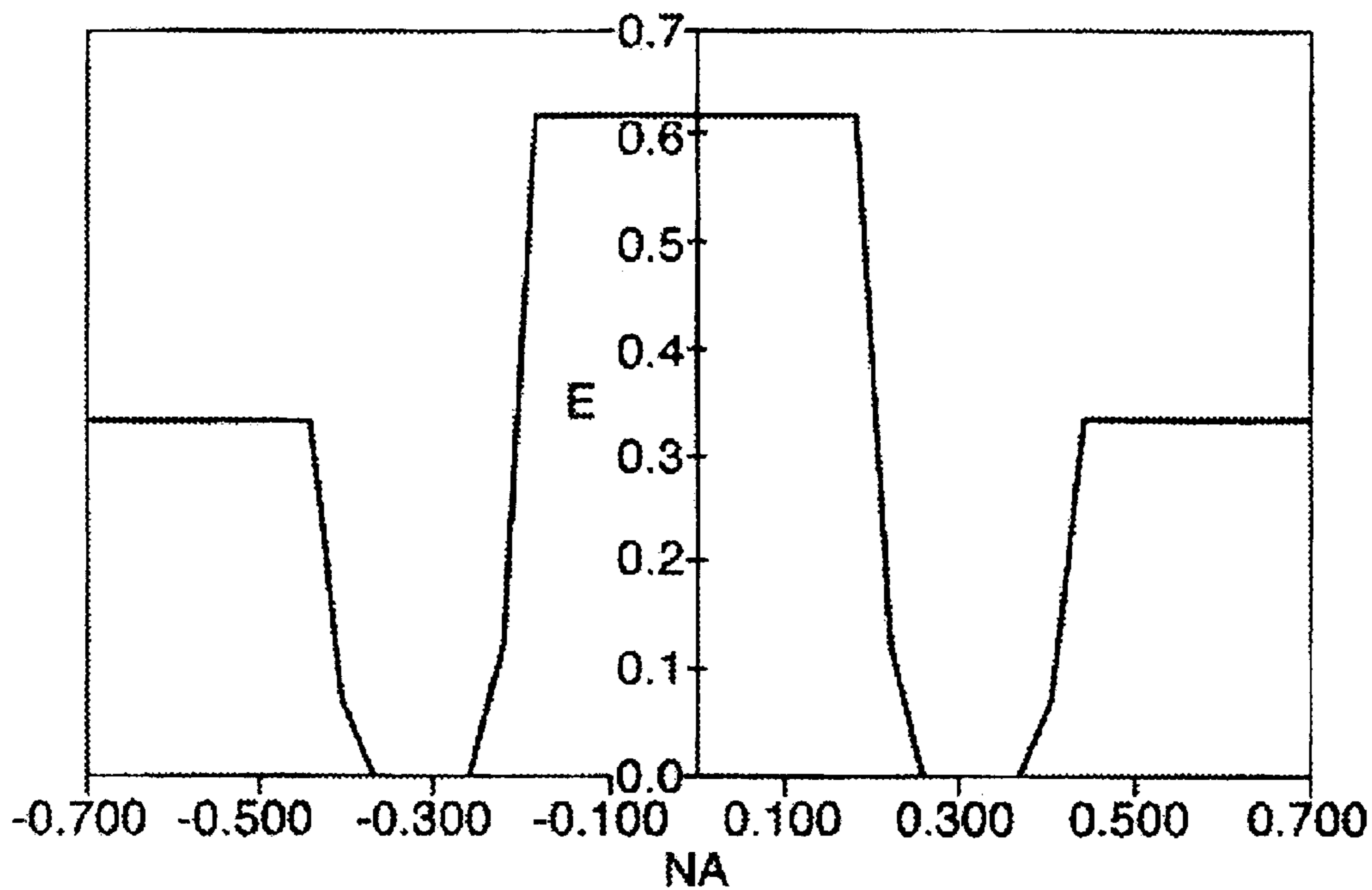

Fig.20(D).

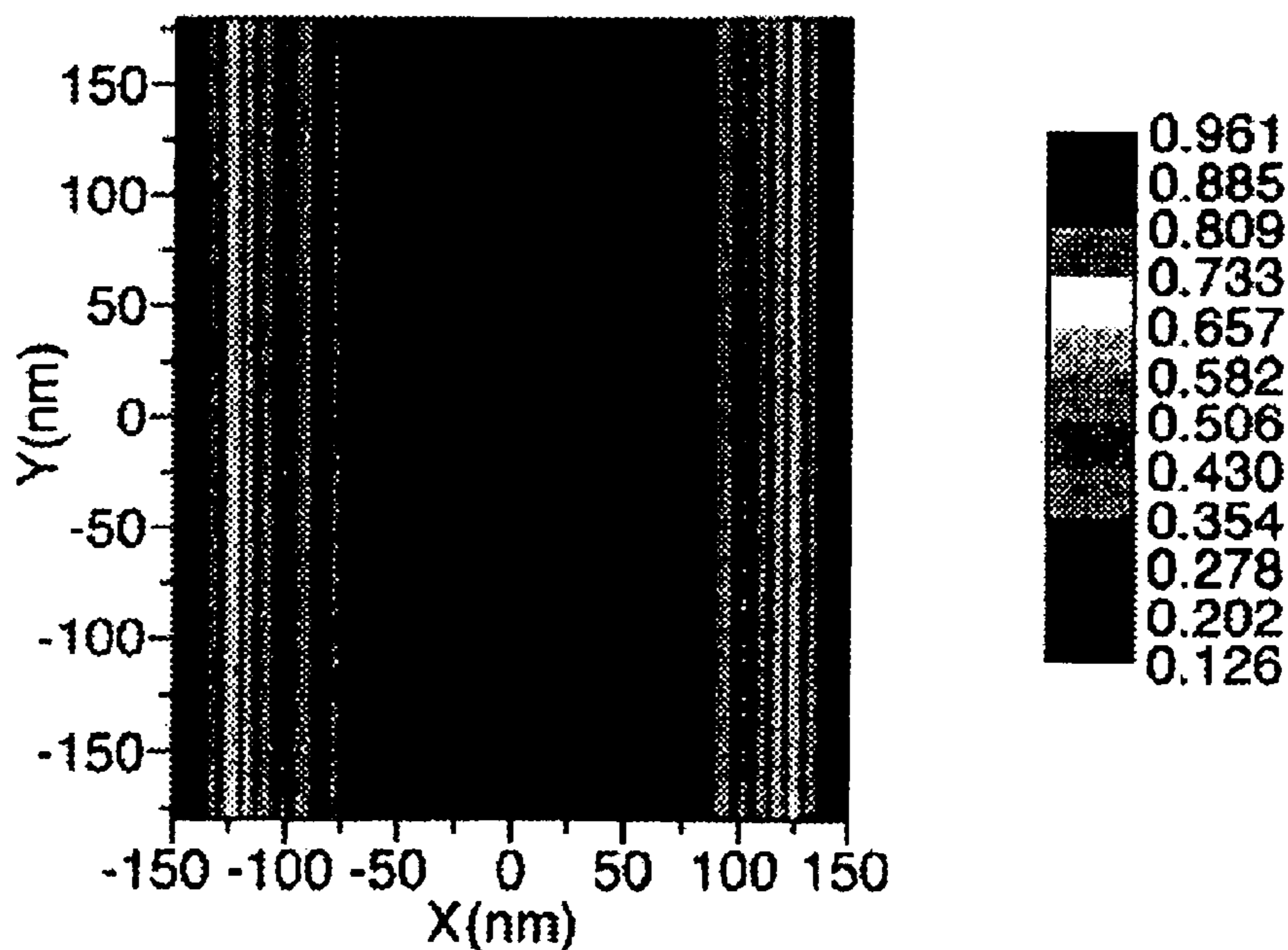

Fig.20(E).

26%T att PSM

400p 26%T

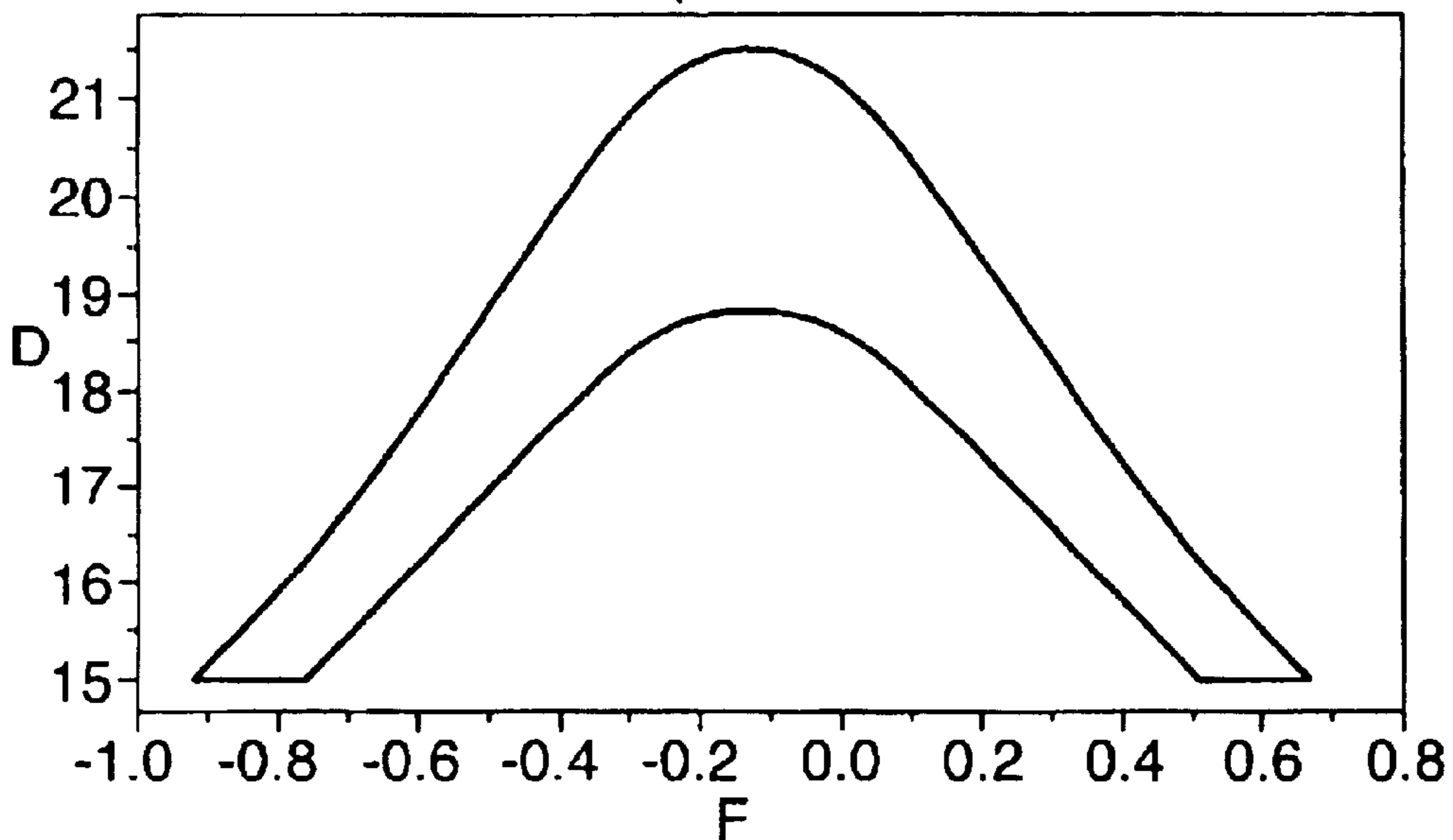

Fig.20(F).

100%T HT PSM

400p 115nm 180nm htp 67%

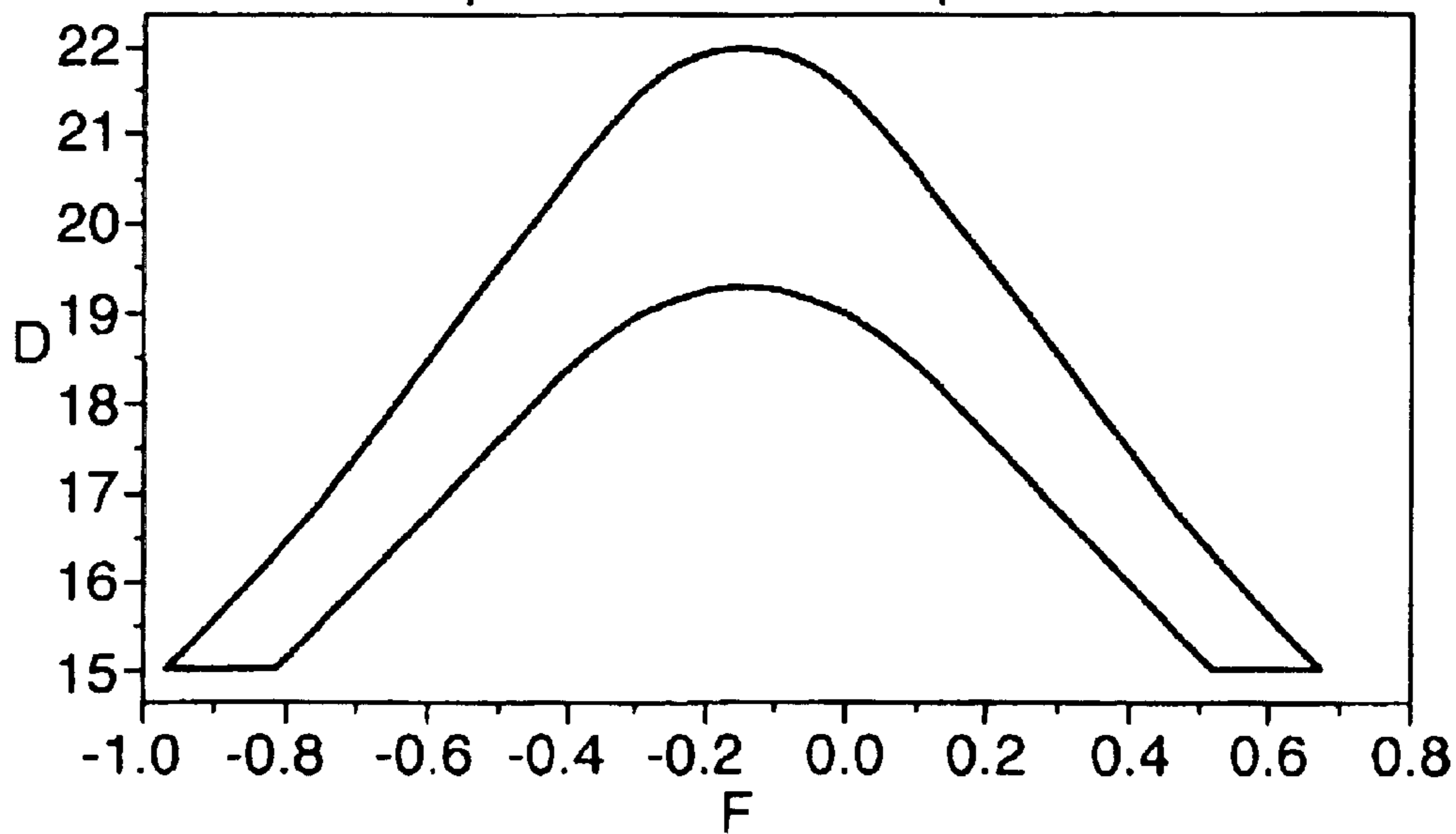

Fig.20(G).

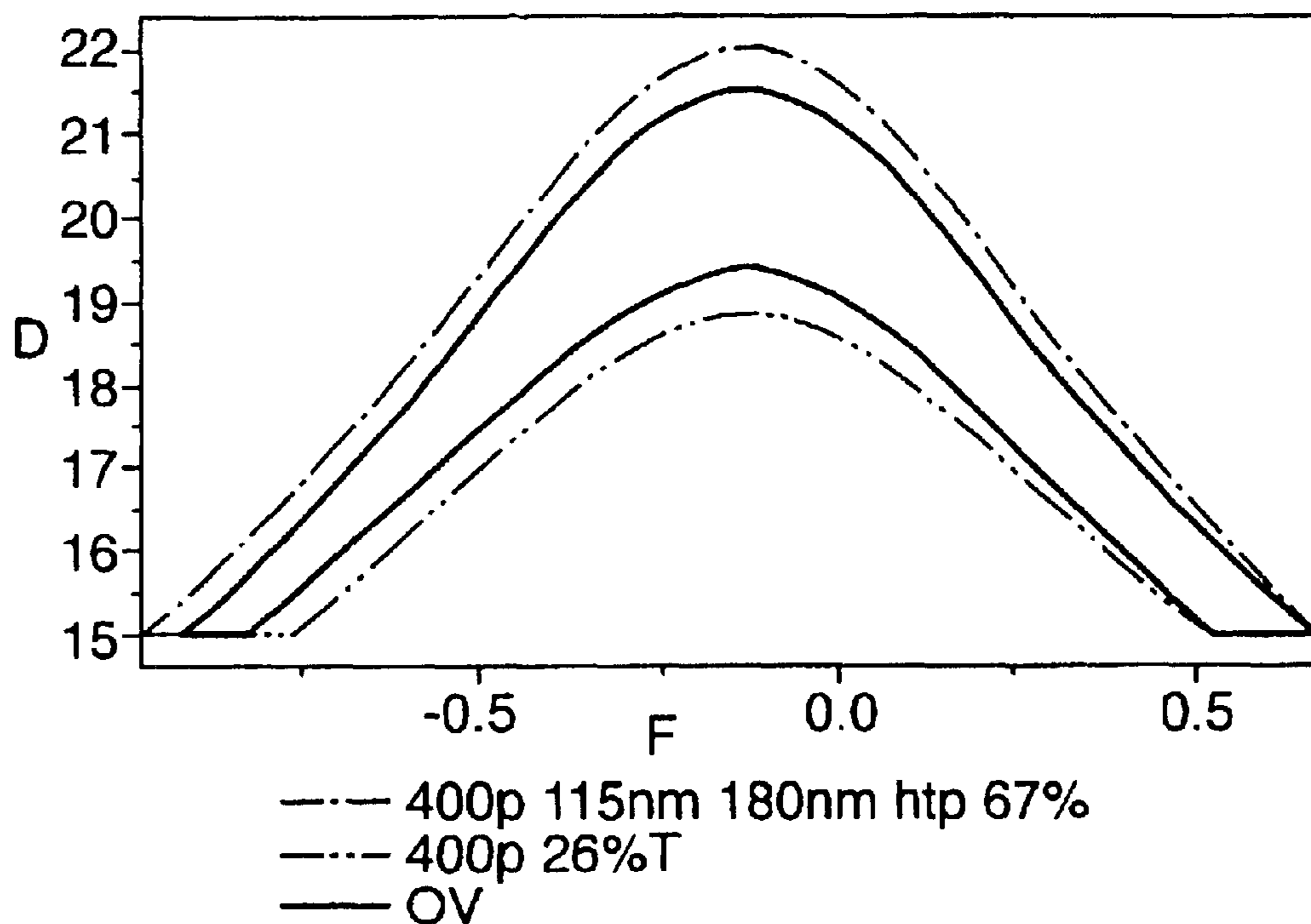

Fig.20(H).

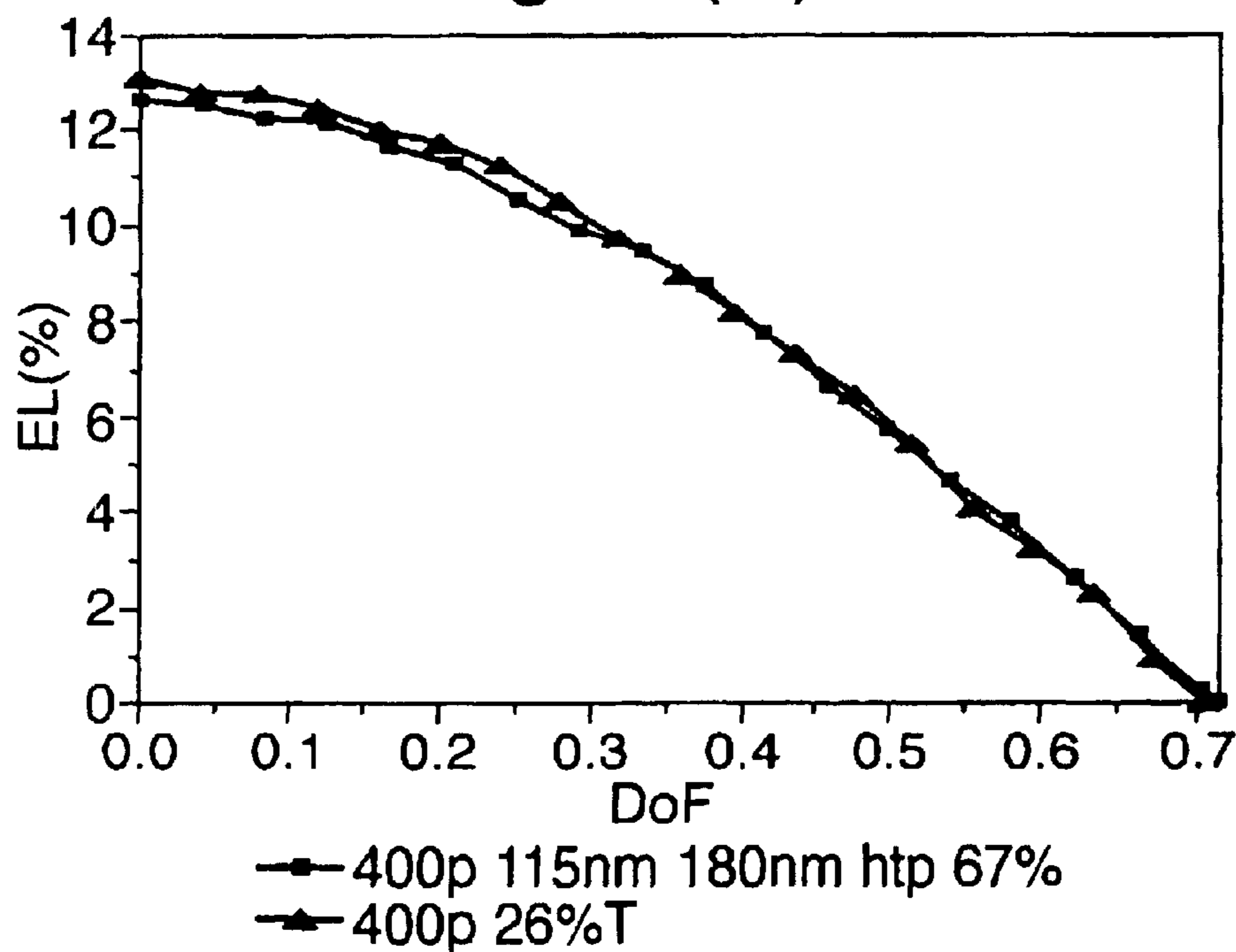

Fig.21(A).

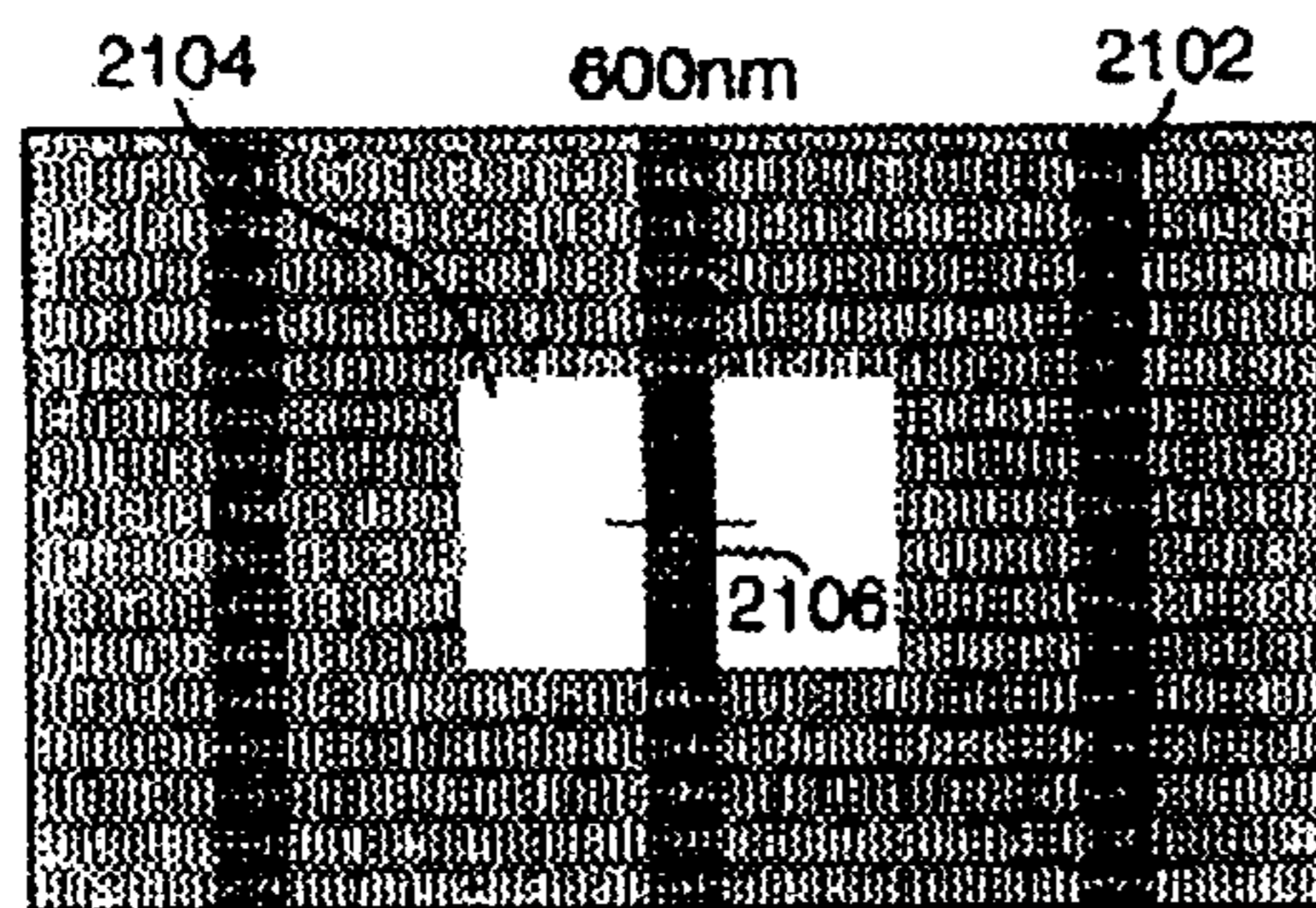

Fig.21(B).

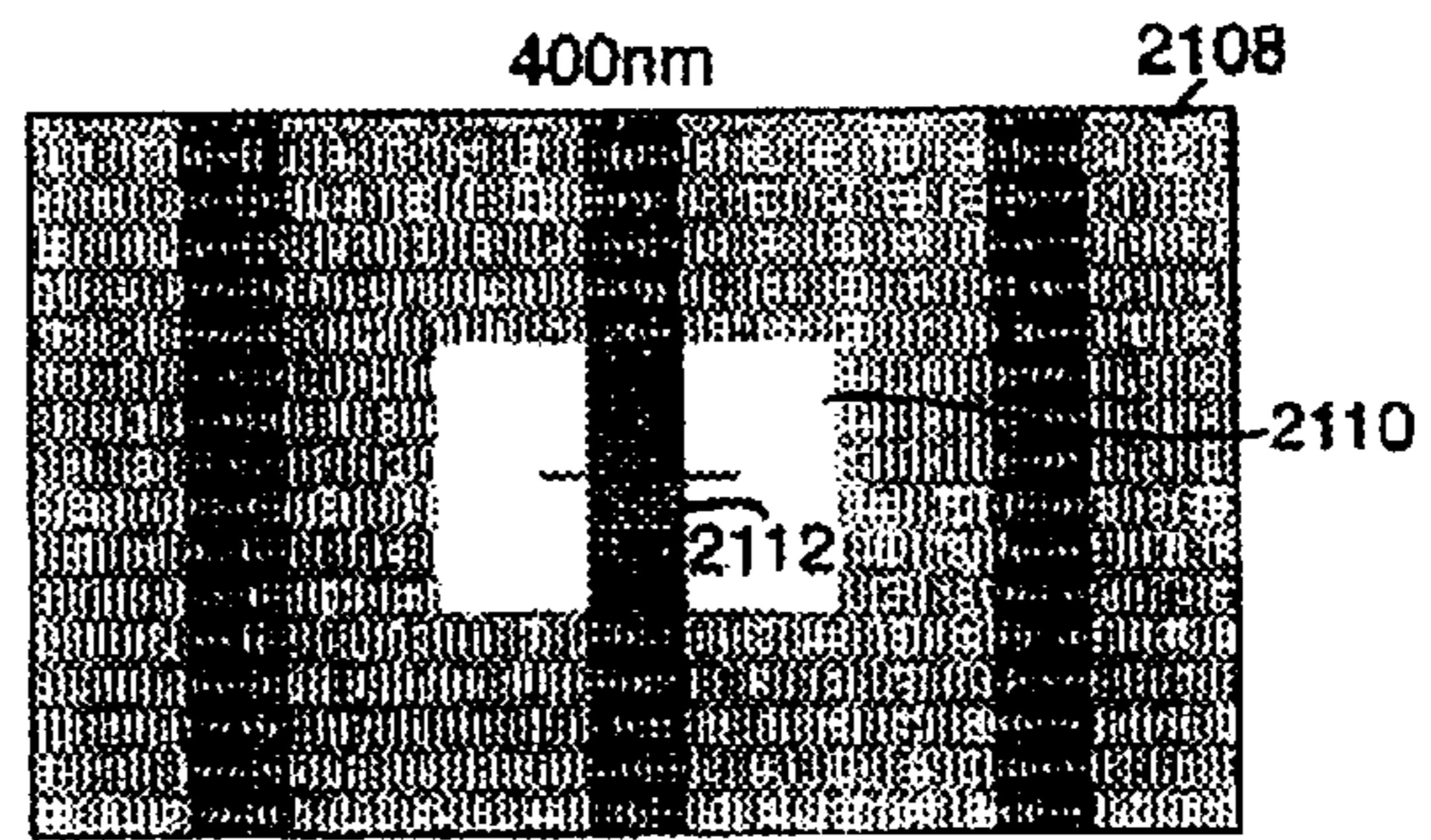

Fig.21(C).

600nm; CrSB

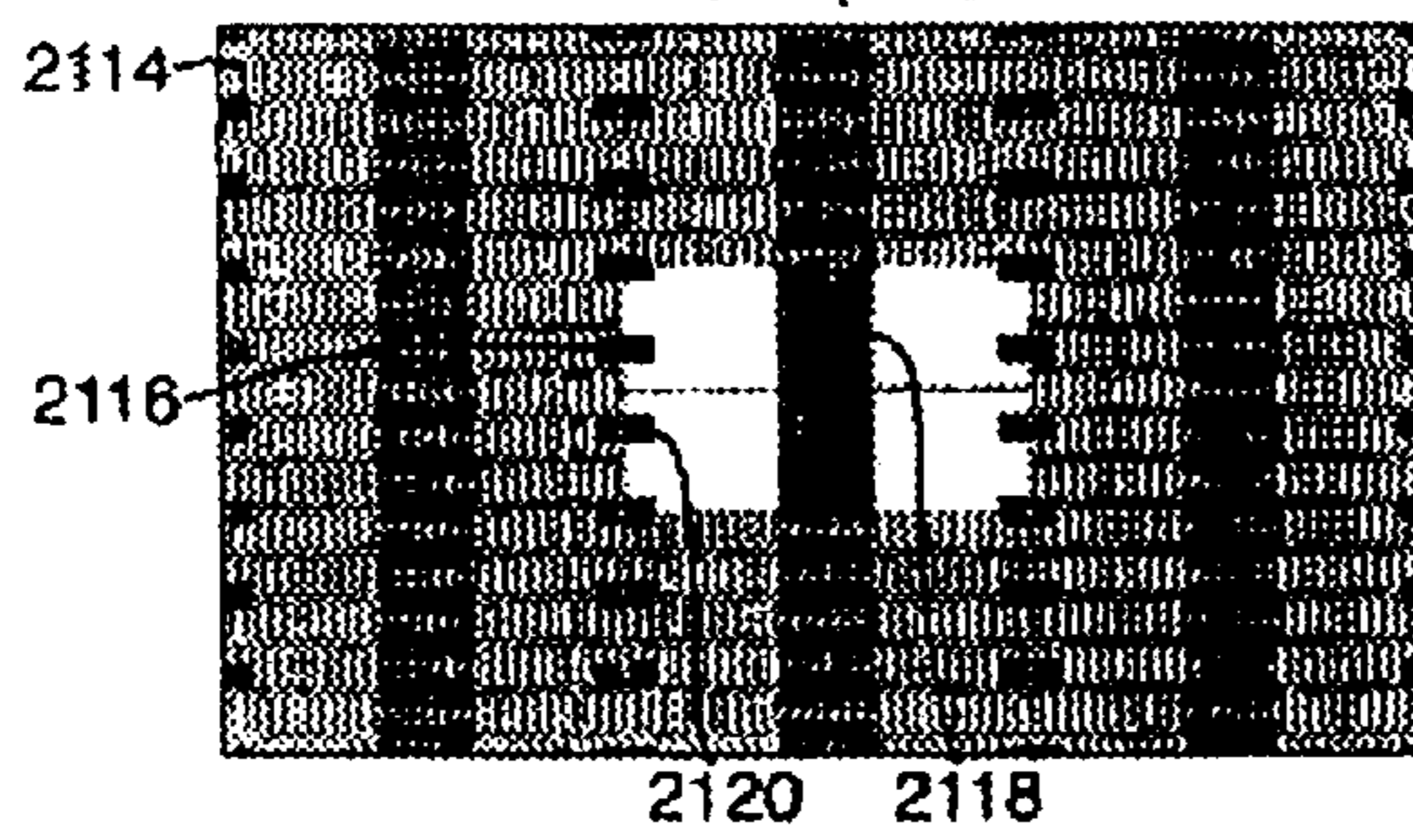

Fig.21(D).

HT 400nm

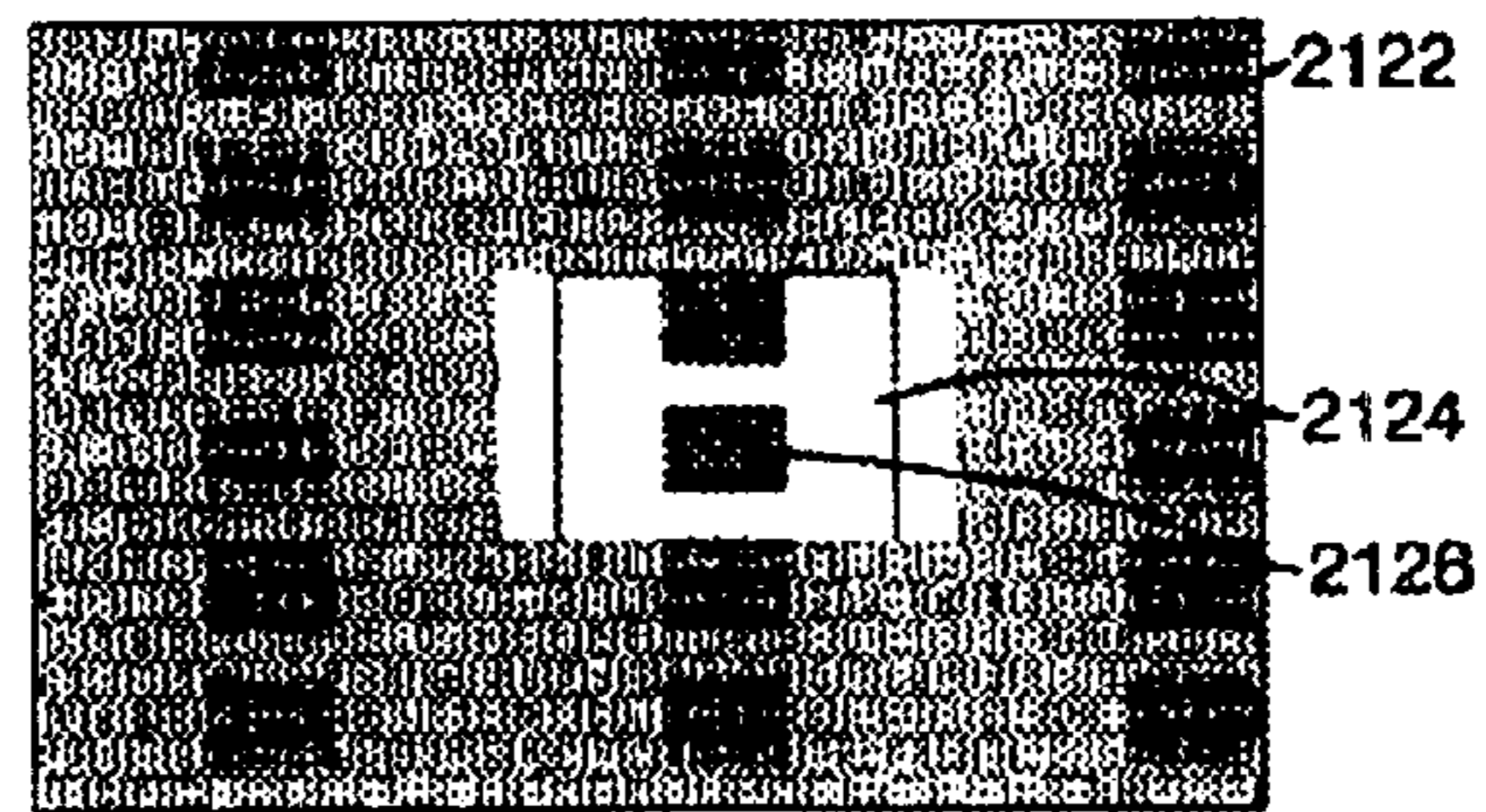

Fig.21(E).

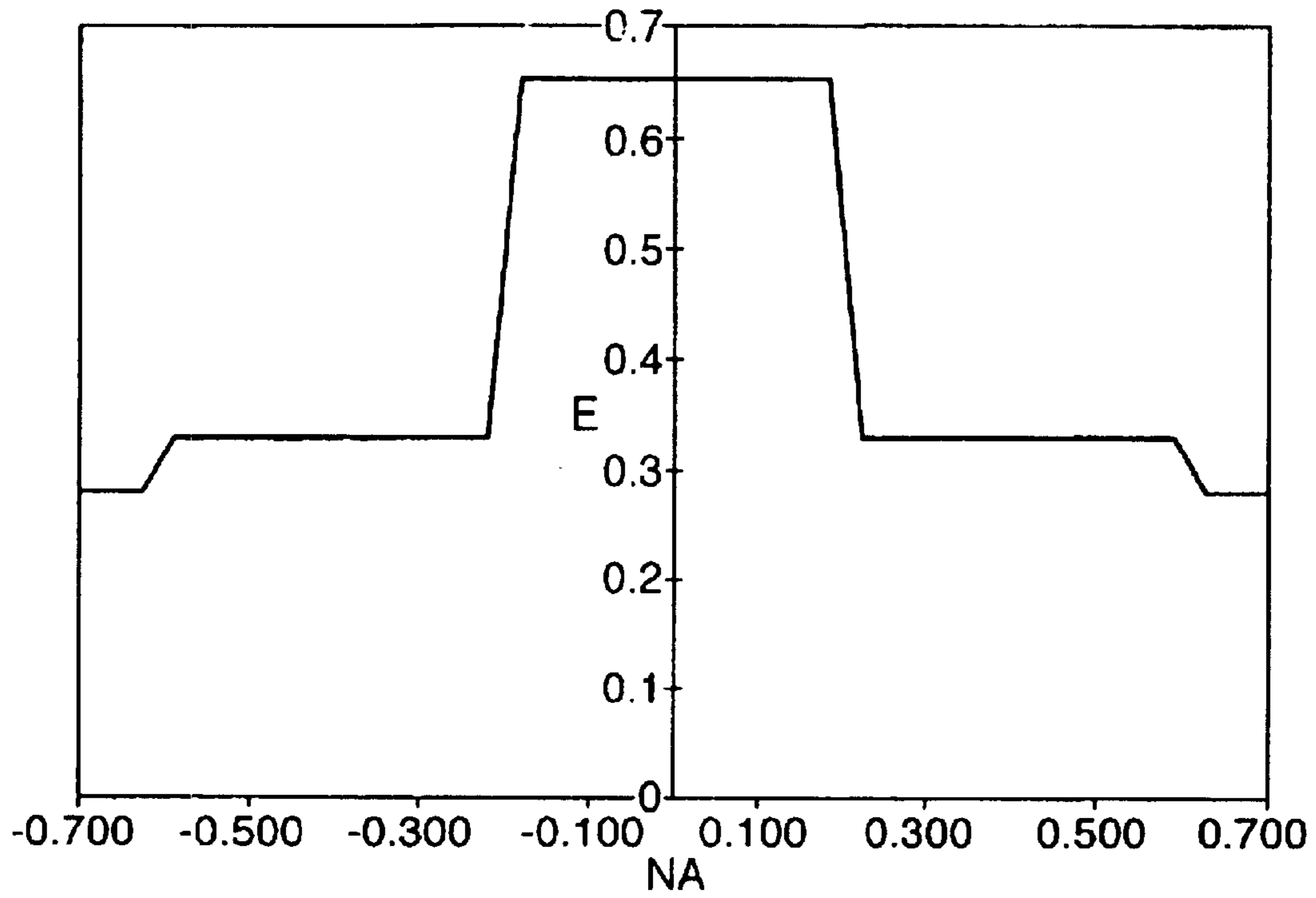

Fig.21(F).

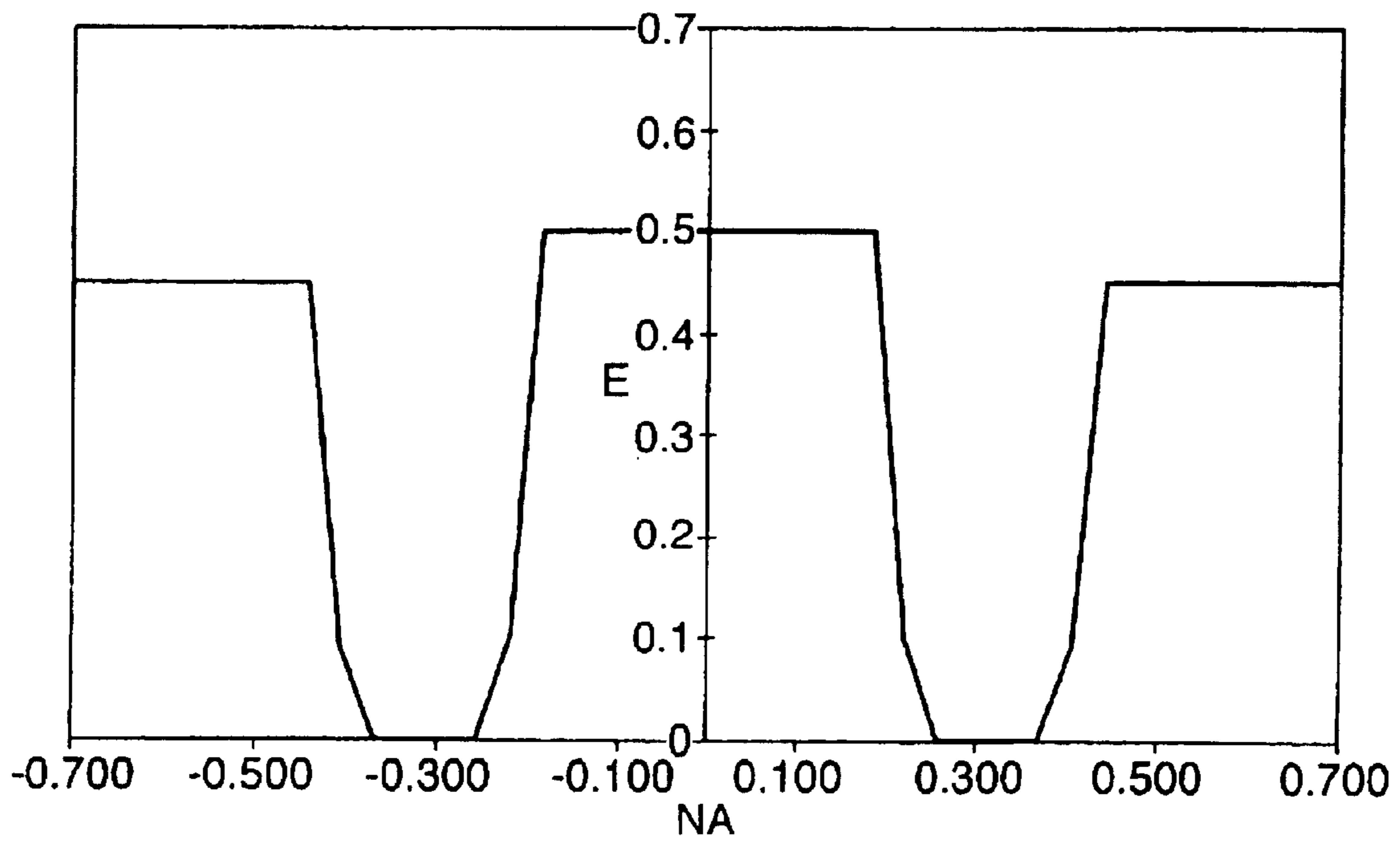

Fig.21(G).

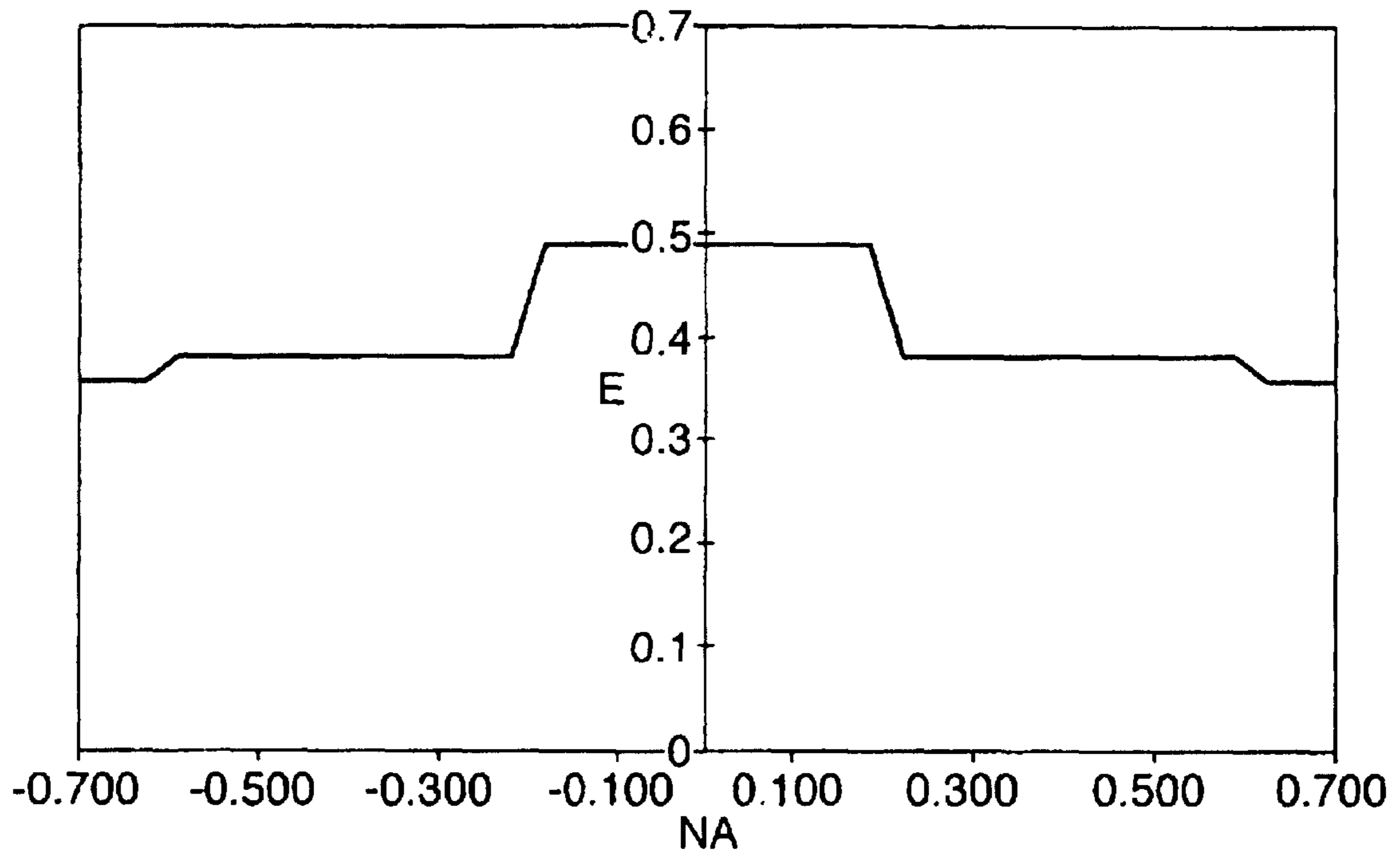

Fig.21(H).

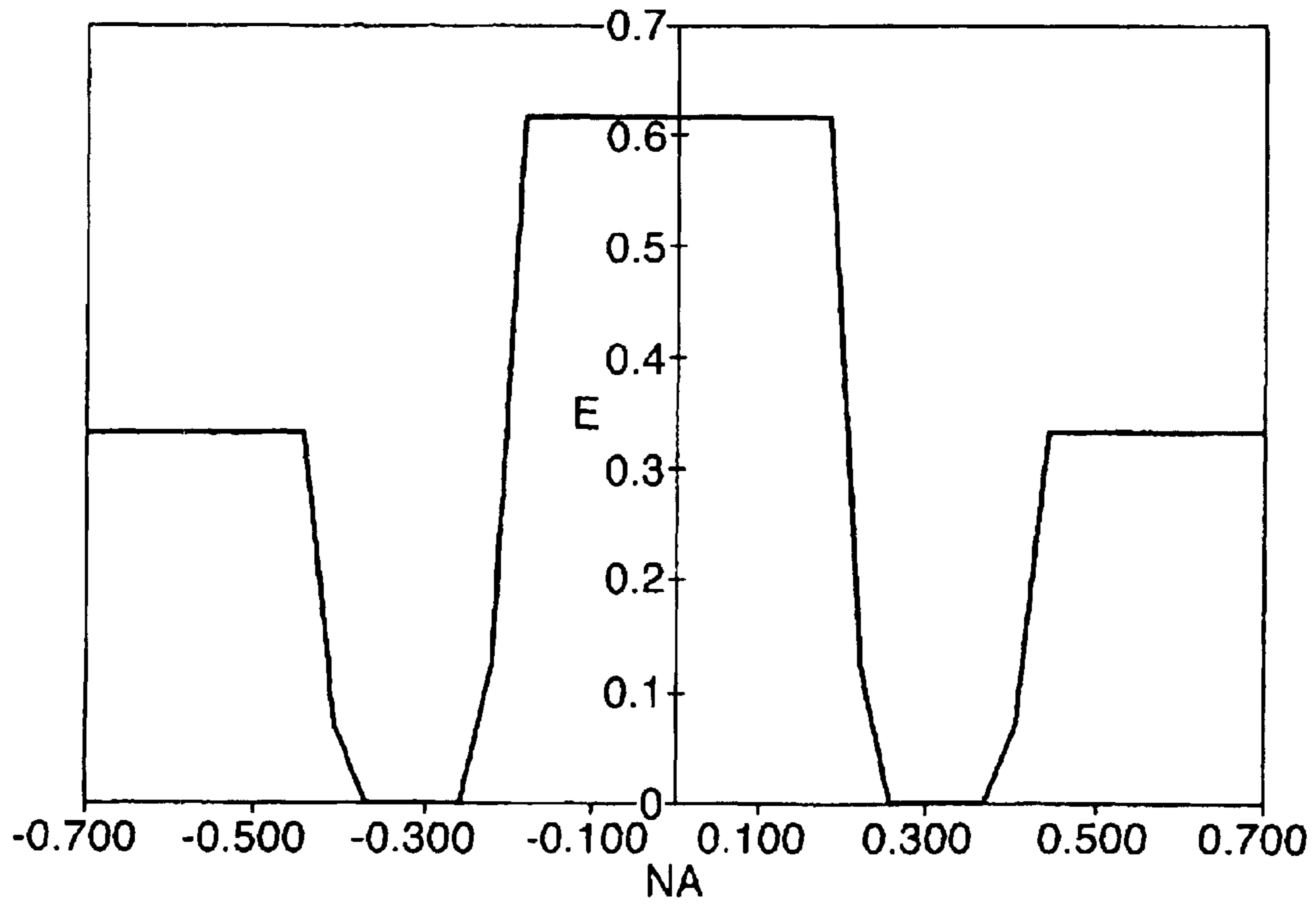

Fig.21(I).

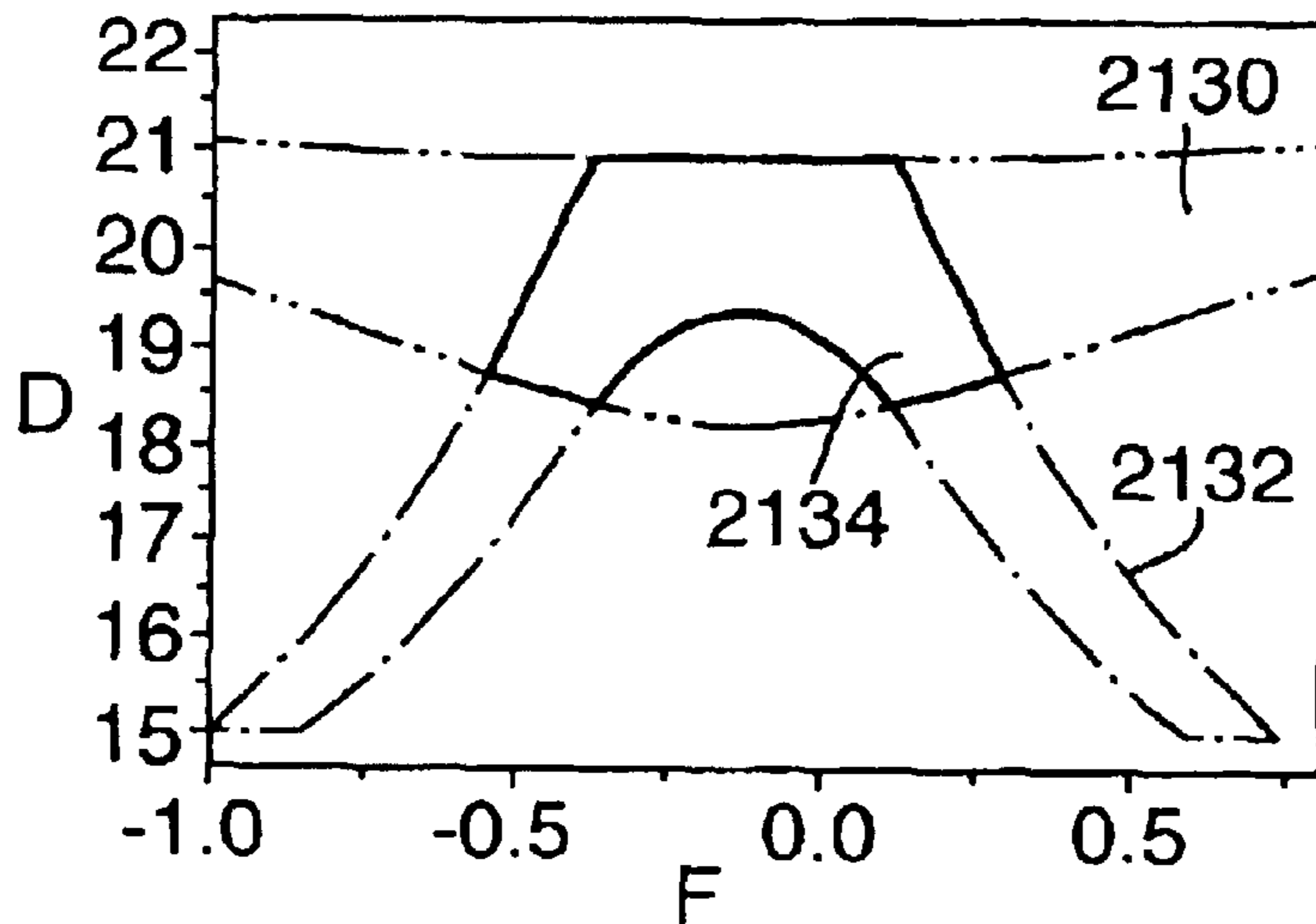

Fig.21(J).

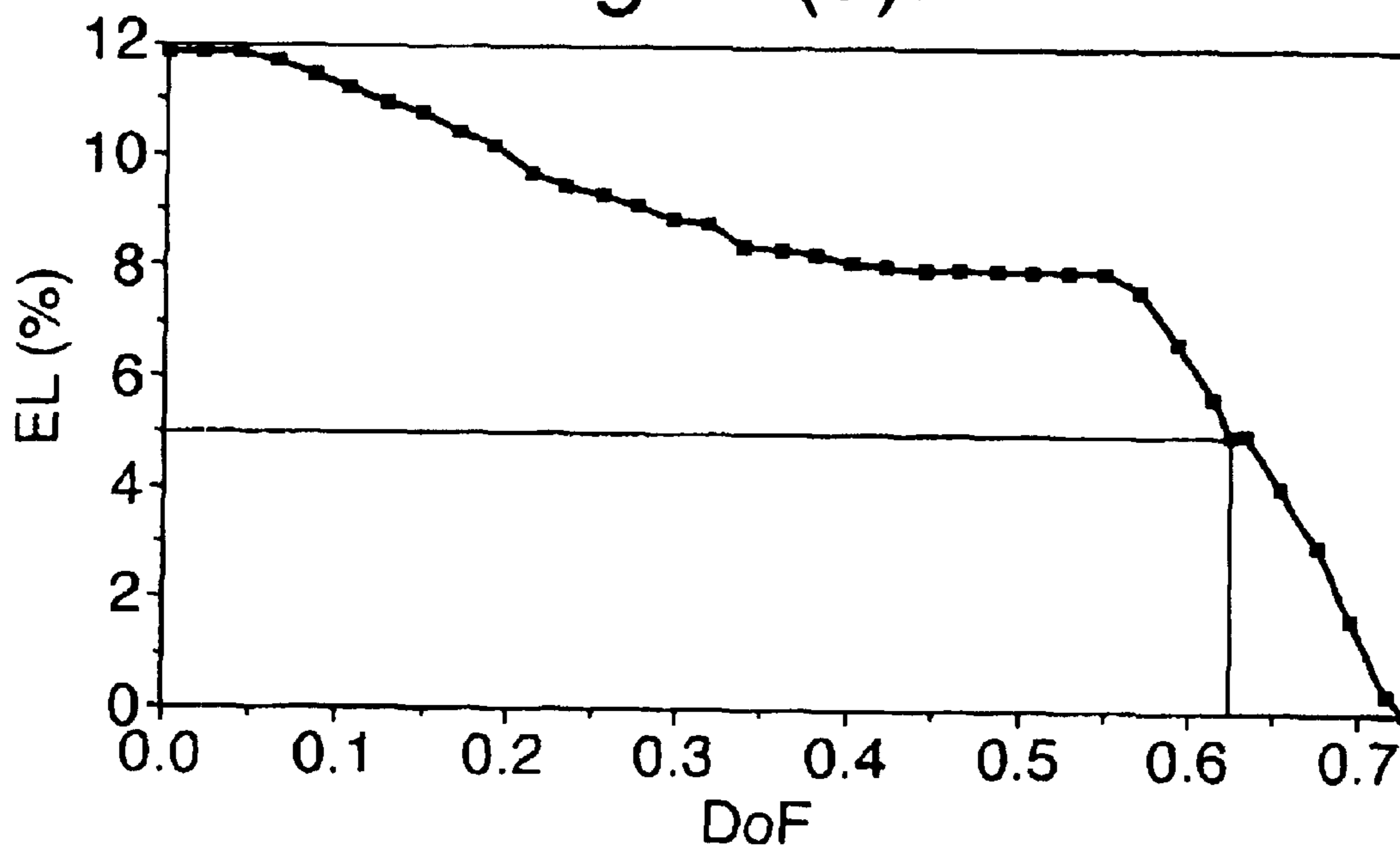

Fig.22(A).

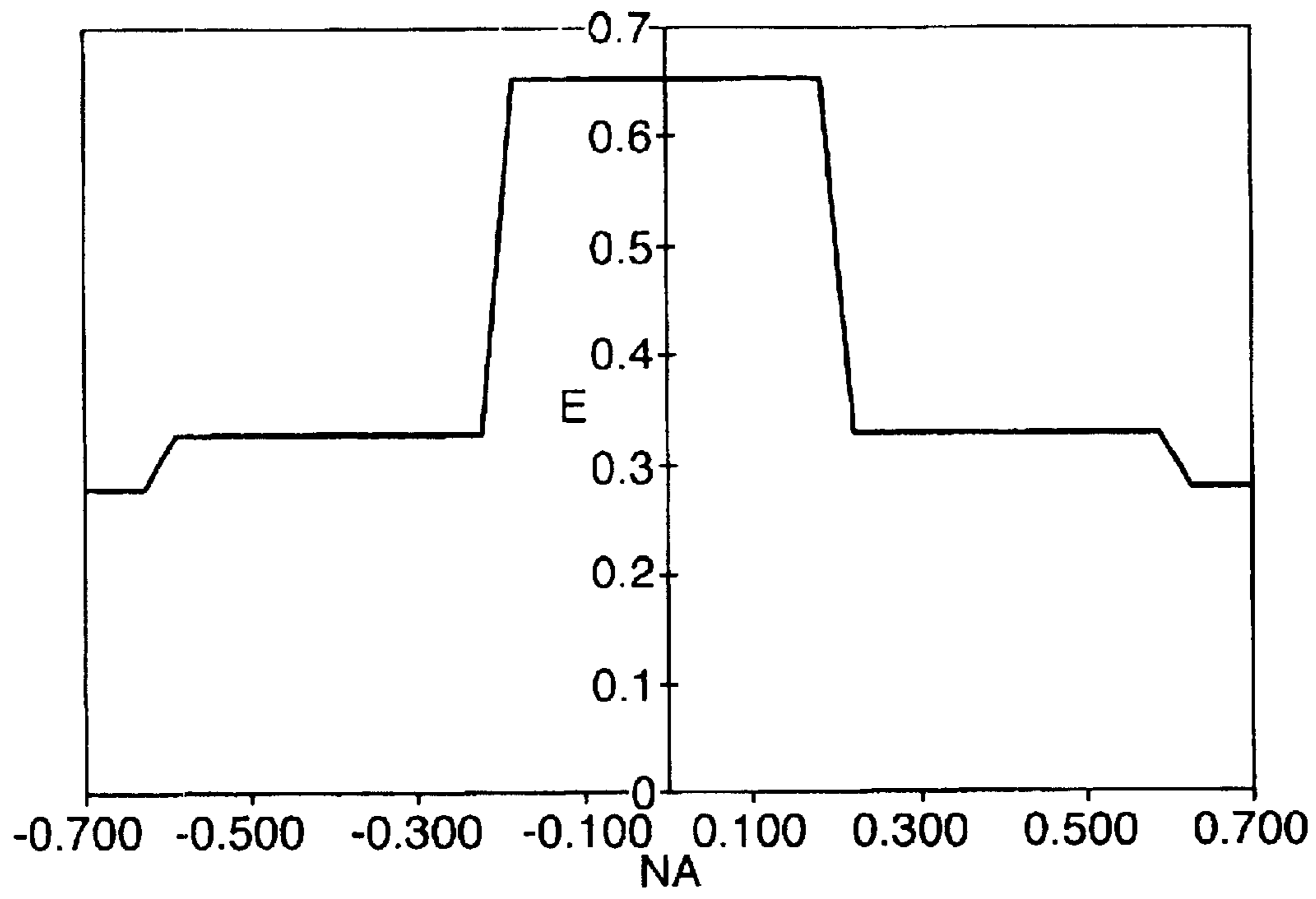

Fig.22(B).

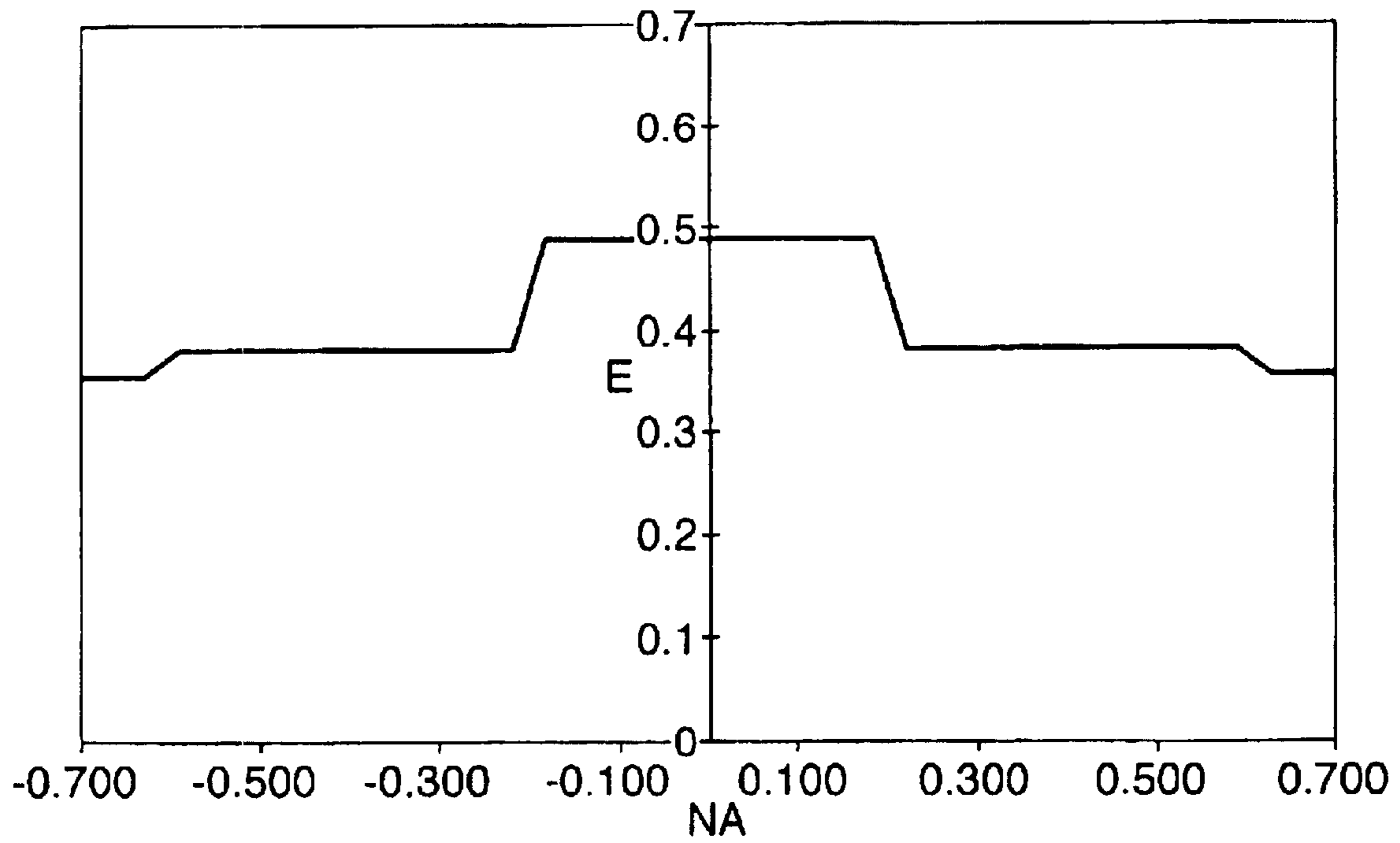

Fig.22(C).

DoF=0.4 μm

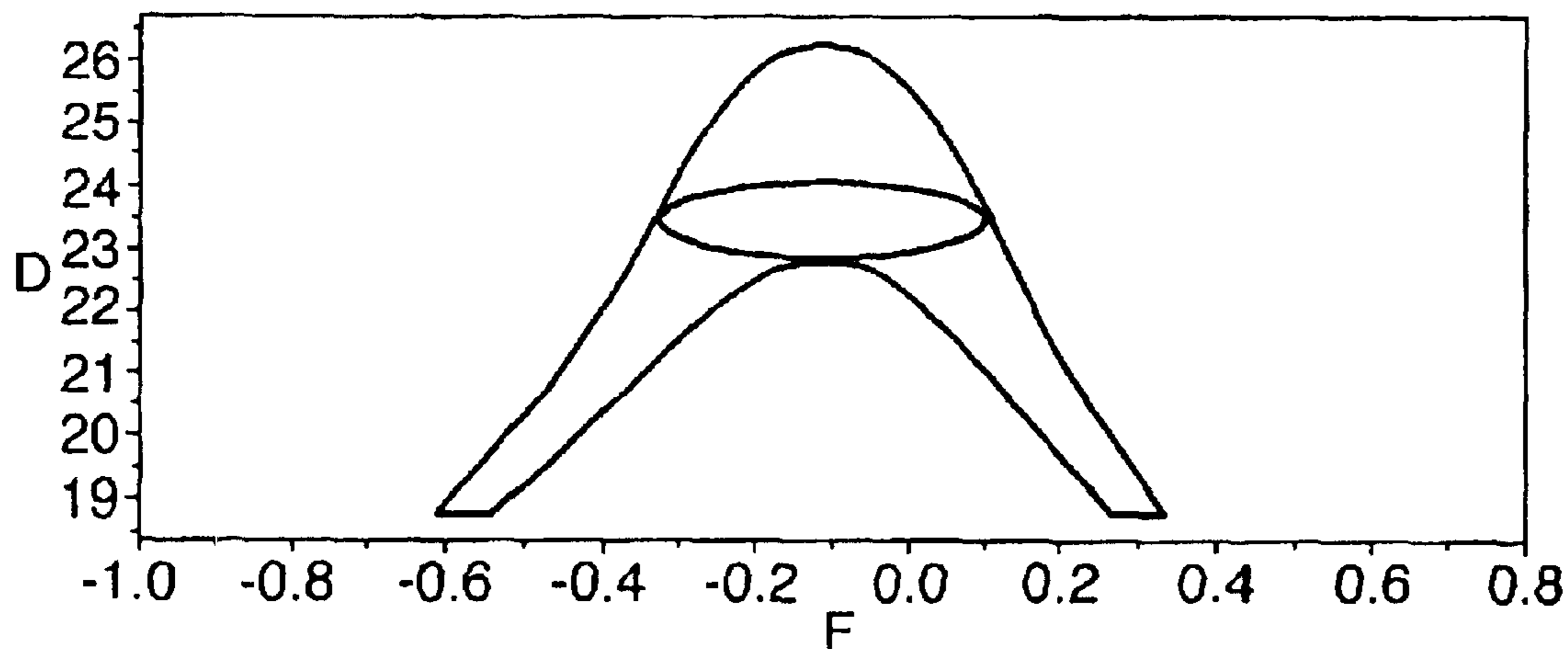

Fig.22(D).

DoF=1.7 μm

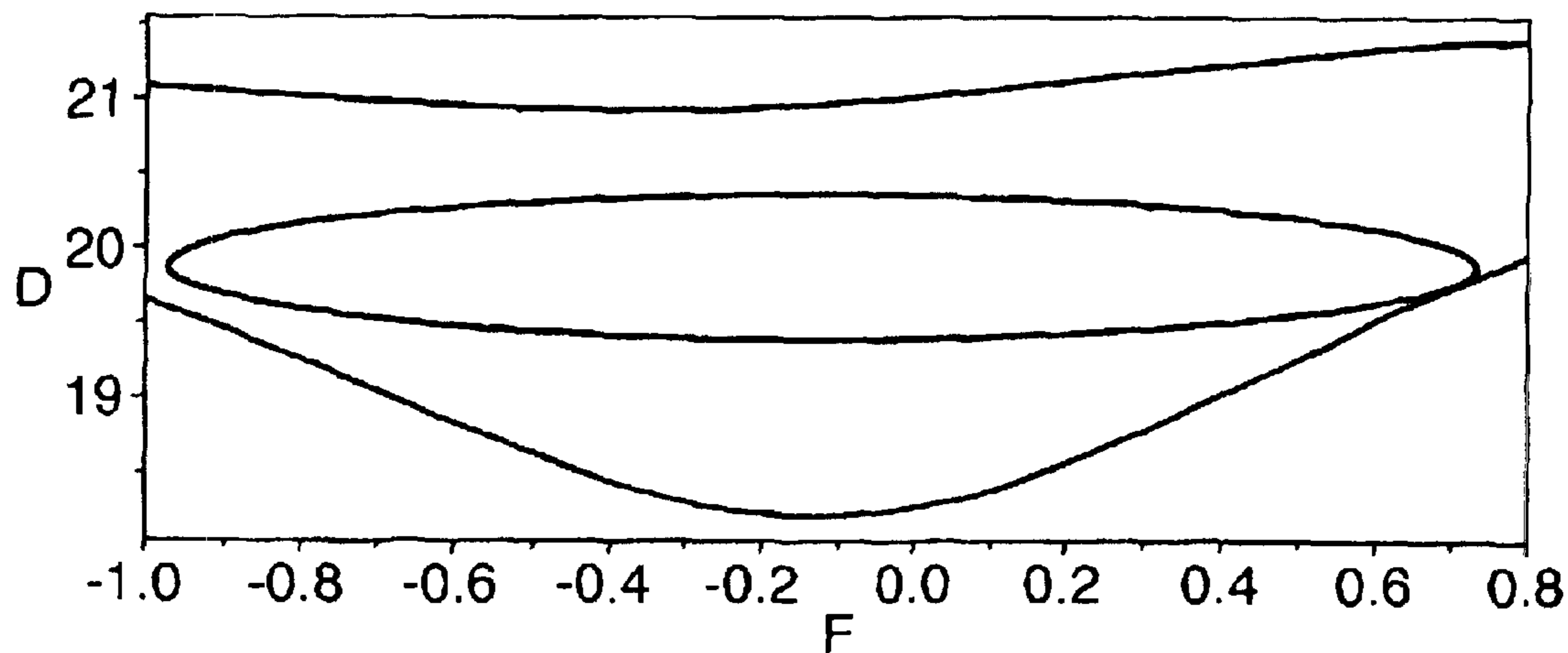

Fig.23(A).

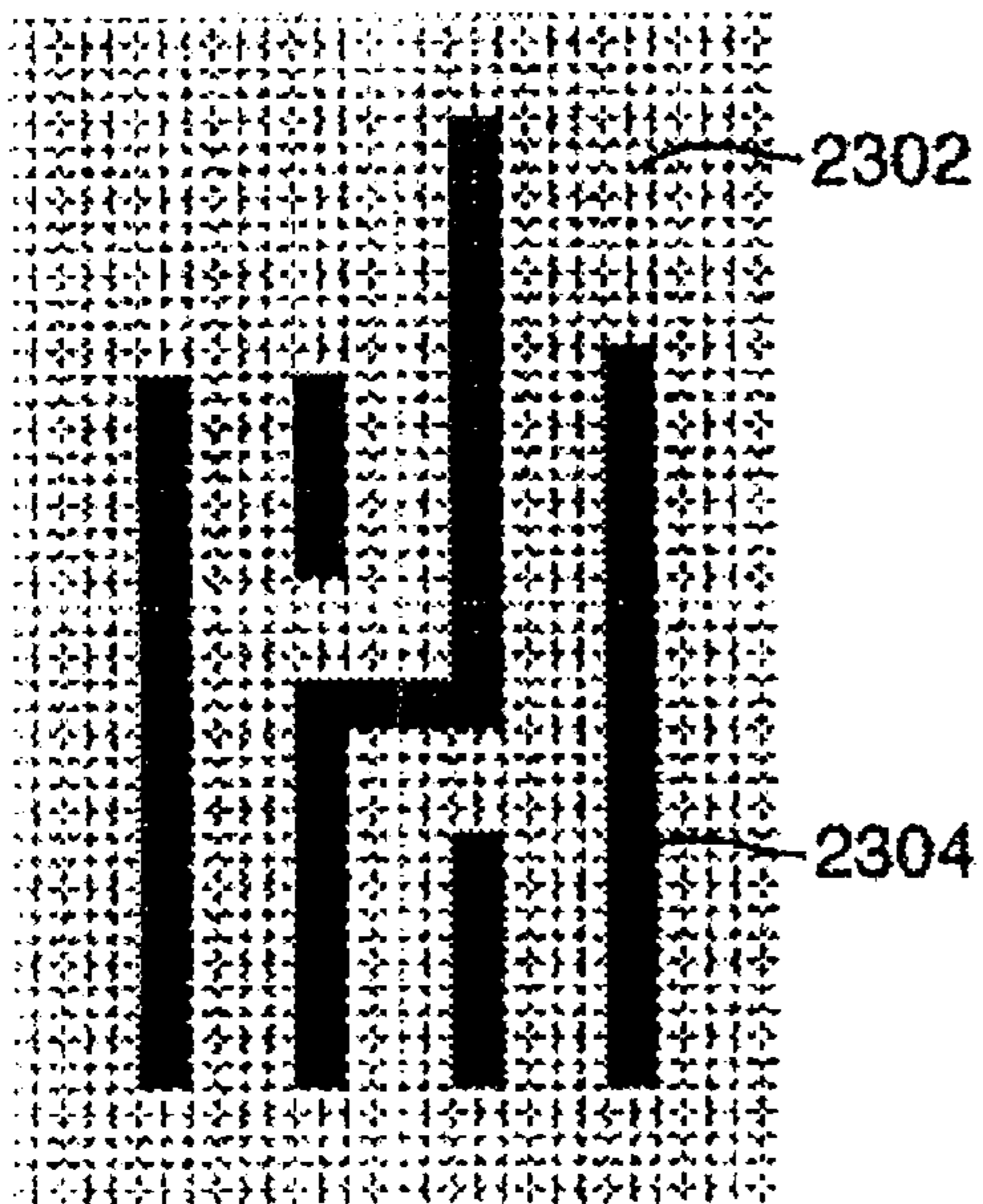

Fig.23(B).

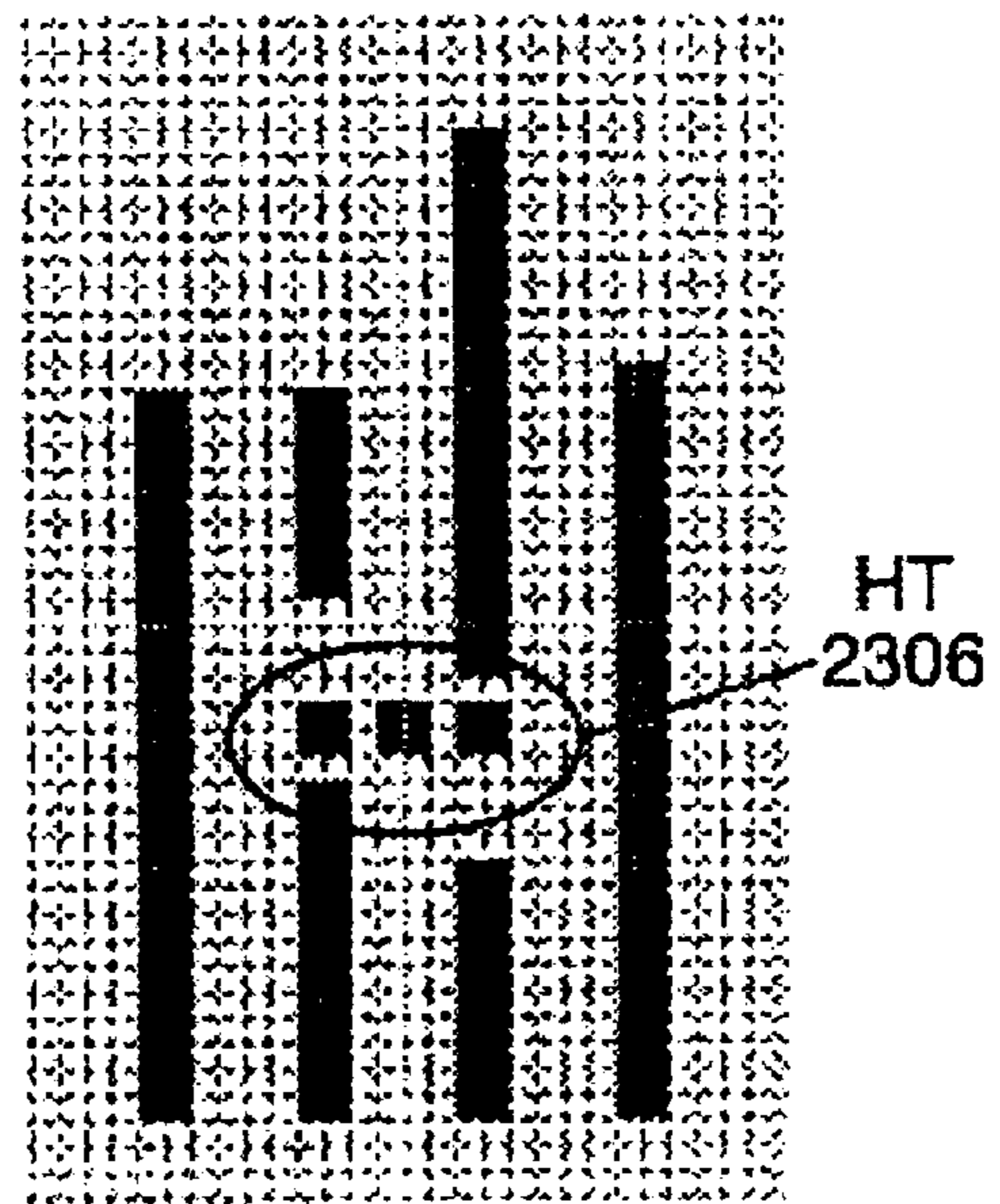

Fig.23(C).

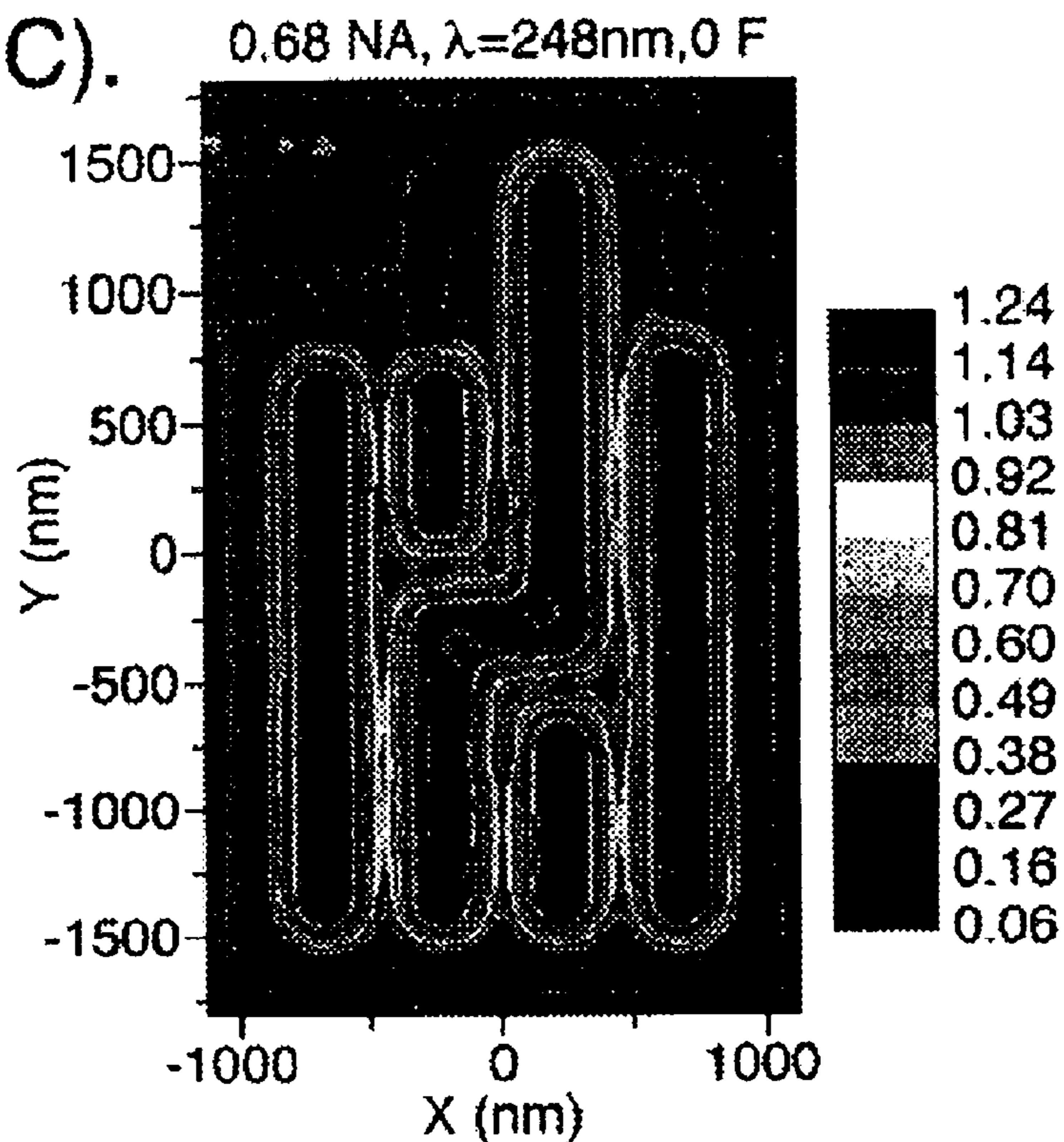

Fig.23(D).

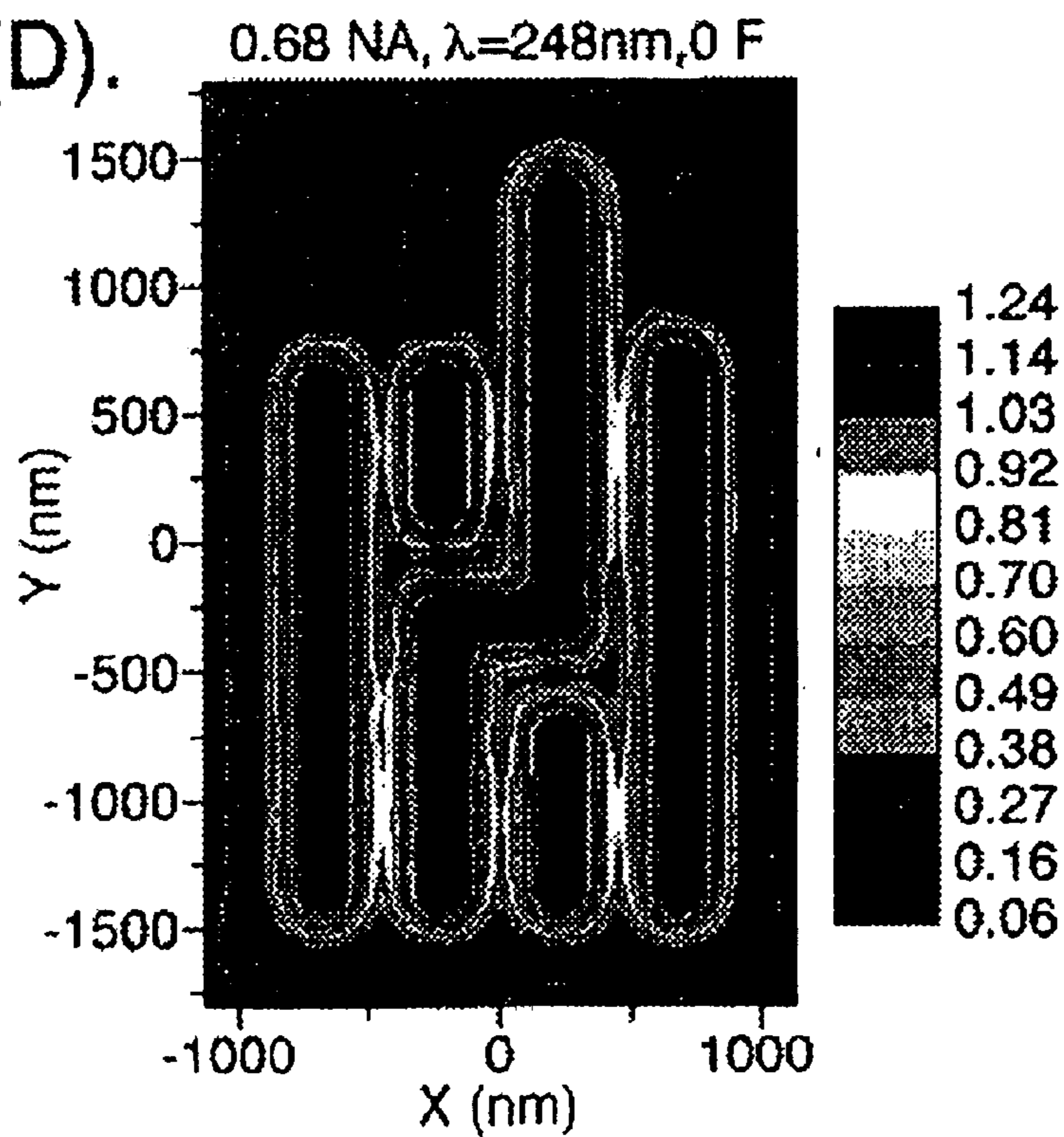

Fig.23(E).

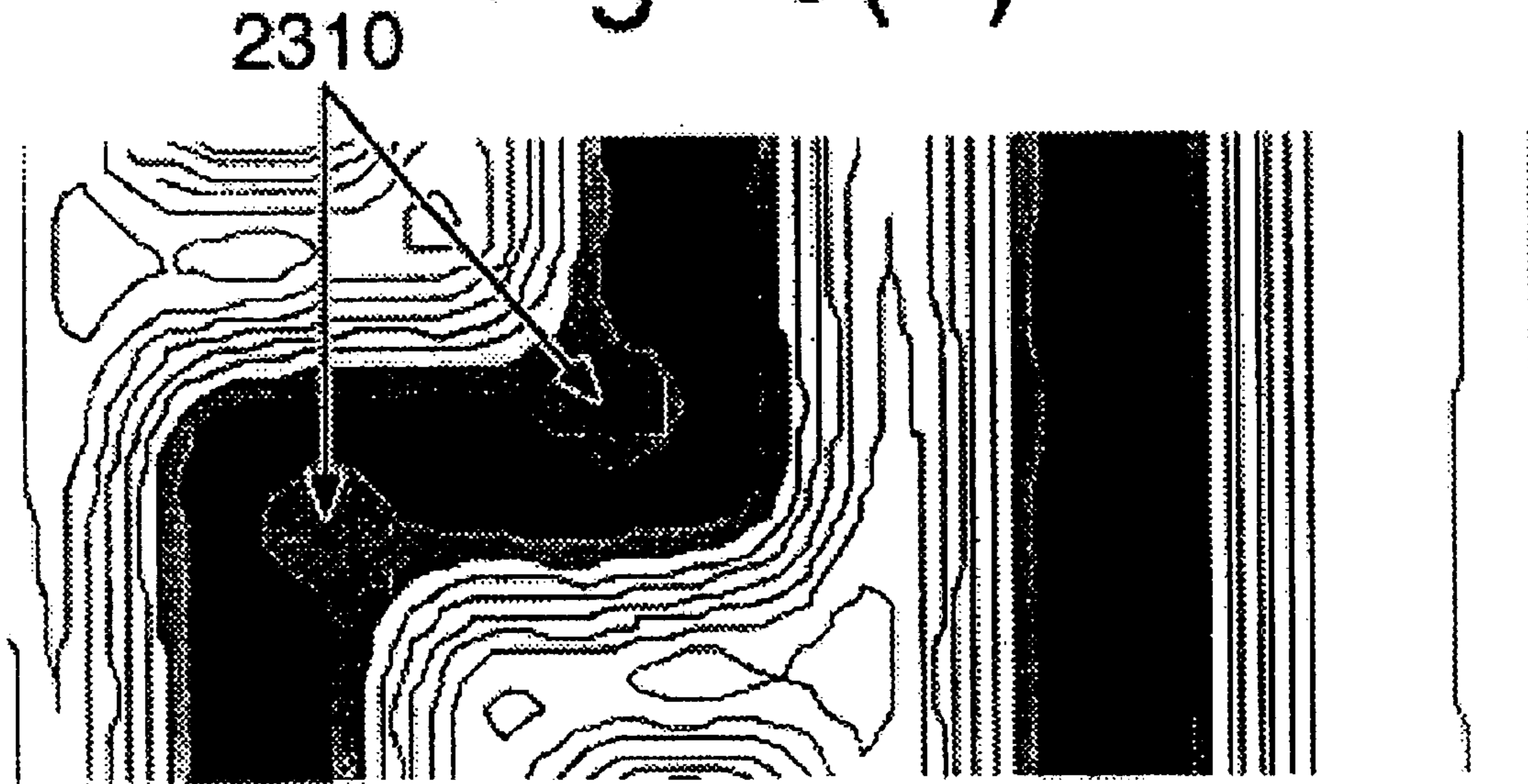

Fig.23(F).

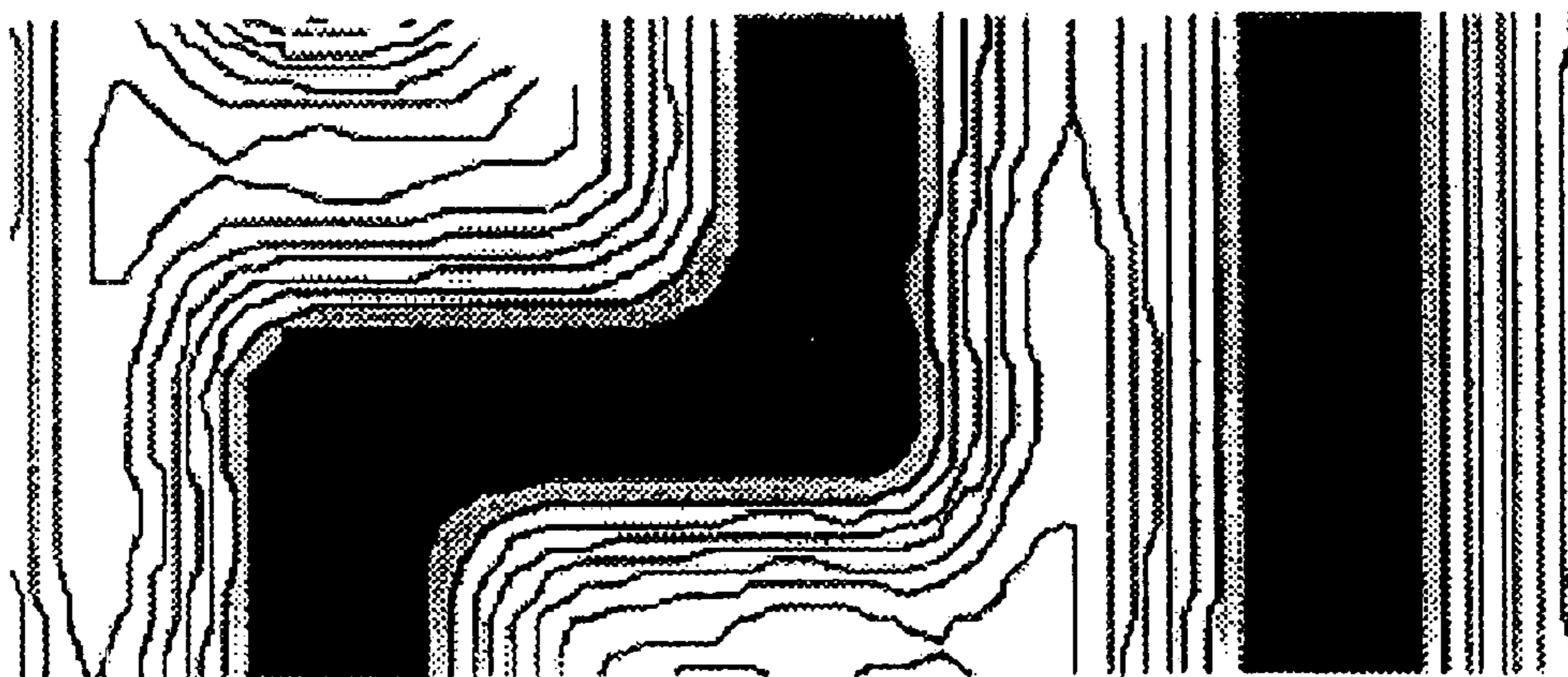

Fig.24.

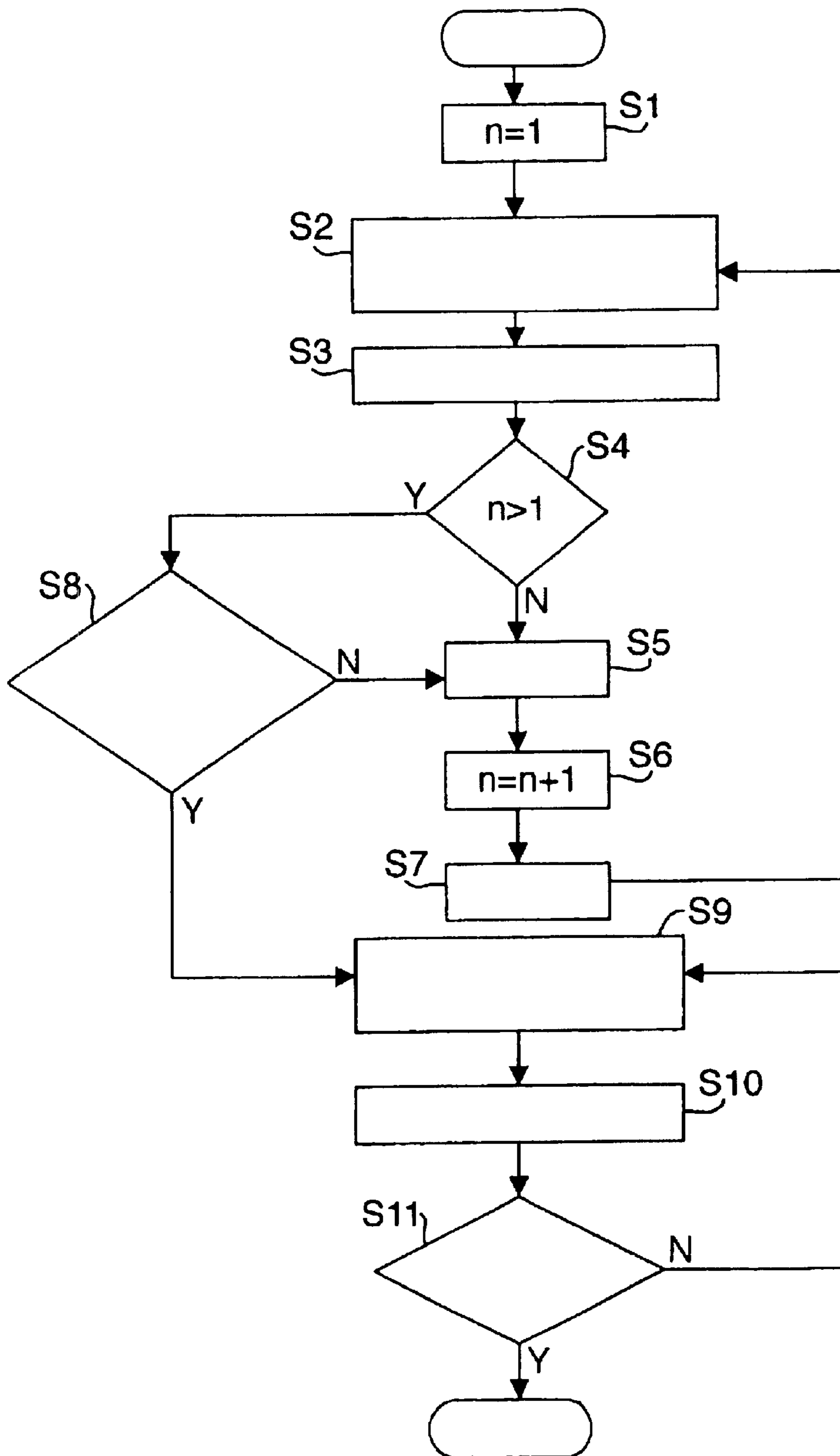
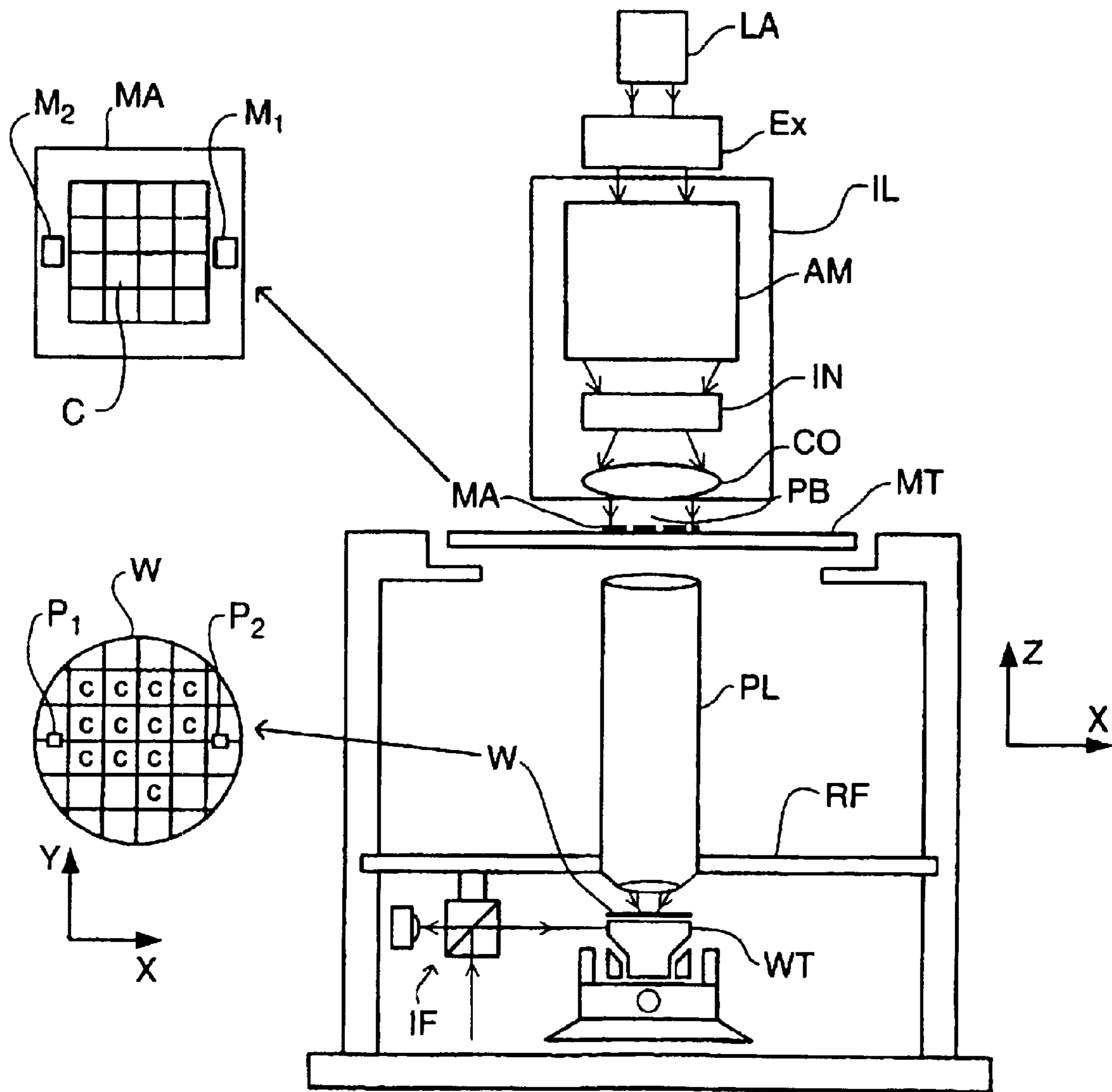

Fig.25.



OPTICAL PROXIMITY CORRECTION

Matter enclosed in heavy brackets [] appears in the original patent but forms no part of this reissue specification; matter printed in italics indicates the additions made by reissue.

This application is a continuation-in-part of application Ser. No. 09/562,445, which was filed on May 1, 2000 now U.S. Pat. No. 6,335,130.

FIELD OF INVENTION

The present invention generally relates to lithography, and more particularly to the design, layout and fabrication of phase-shifting masks that can be used in the manufacture of semiconductor and other devices.

The present invention also relates to the use of such masks in a lithographic apparatus, comprising for example:

- a radiation system for supplying a projection beam of radiation;
- a mask table for holding a mask;
- a substrate table for holding a substrate; and
- a projection system for projecting at least part of a pattern on the mask onto a target portion of the substrate.

BACKGROUND OF THE INVENTION

Lithographic apparatus can be used, for example, in the manufacture of integrated circuits (ICs). In such a case, the mask may contain a circuit pattern corresponding to an individual layer of the IC, and this pattern can be imaged onto a target portion (e.g. comprising one or more dies) on a substrate (silicon wafer) that has been coated with a layer of radiation-sensitive material (resist). In general, a single wafer will contain a whole network of adjacent target portions that are successively irradiated via the projection system, one at a time. In one type of lithographic projection apparatus, each target portion is irradiated by exposing the entire mask pattern onto the target portion in one go; such an apparatus is commonly referred to as a wafer stepper. In an alternative apparatus—commonly referred to as a step-and-scan apparatus—each target portion is irradiated by progressively scanning the mask pattern under the projection beam in a given reference direction (the “scanning” direction) while synchronously scanning the substrate table parallel or anti-parallel to this direction; since, in general, the projection system will have a magnification factor M (generally <1), the speed V at which the substrate table is scanned will be a factor M times that at which the mask table is scanned. More information with regard to lithographic devices as here described can be gleaned, for example, from U.S. Pat. No. 6,046,792, incorporated herein by reference.

In a manufacturing process using a lithographic projection apparatus, a mask pattern is imaged onto a substrate that is at least partially covered by a layer of radiation-sensitive material (resist). Prior to this imaging step, the substrate may undergo various procedures, such as priming, resist coating and a soft bake. After exposure, the substrate may be subjected to other procedures, such as a post-exposure bake (PEB), development, a hard bake and measurement/inspection of the imaged features. This array of procedures is used as a basis to pattern an individual layer of a device, e.g. an IC. Such a patterned layer may then undergo various processes such as etching, ion-implantation (doping), metallization, oxidation, chemo-mechanical polishing, etc., all intended to finish off an individual layer. If several layers

are required, then the whole procedure, or a variant thereof, will have to be repeated for each new layer. Eventually, an array of devices will be present on the substrate (wafer). These devices are then separated from one another by a technique such as dicing or sawing, whence the individual devices can be mounted on a carrier, connected to pins, etc. Further information regarding such processes can be obtained, for example, from the book “Microchip Fabrication: A Practical Guide to Semiconductor Processing”, Third Edition, by Peter van Zant, McGraw Hill Publishing Co., 1997, ISBN 0-07-067250-4, incorporated herein by reference.

For the sake of simplicity, the projection system may hereinafter be referred to as the “lens”; however, this term should be broadly interpreted as encompassing various types of projection system, including refractive optics, reflective optics, and catadioptric systems, for example. The radiation system may also include components operating according to any of these design types for directing, shaping or controlling the projection beam of radiation, and such components may also be referred to below, collectively or singularly, as a “lens”. Further, the lithographic apparatus may be of a type having two or more substrate tables (and/or two or more mask tables). In such “multiple stage” devices the additional tables may be used in parallel, or preparatory steps may be carried out on one or more tables while one or more other tables are being used for exposures. Twin stage lithographic apparatus are described, for example, in U.S. Pat. No. 5,969,441 and WO 98/40791, incorporated herein by reference.

Although specific reference may be made in this text to the use of lithographic apparatus and masks in the manufacture of ICs, it should be explicitly understood that such apparatus and masks have many other possible applications. For example, they may be used in the manufacture of integrated optical systems, guidance and detection patterns for magnetic domain memories, liquid-crystal display panels, thin-film magnetic heads, etc. The skilled artisan will appreciate that, in the context of such alternative applications, any use of the terms “reticle”, “wafer” or “die” in this text should be considered as being replaced by the more general terms “mask”, “substrate” and “target portion”, respectively.

In the present document, the terms “radiation” and “beam” are used to encompass all types of electromagnetic radiation, including ultraviolet radiation (e.g. with a wavelength of 365, 248, 193, 157 or 126 nm) and EUV (extreme ultra-violet radiation, e.g. having a wavelength in the range 5-20 nm).

A lithographic mask typically may contain opaque and transparent regions formed in a predetermined pattern. The exposure radiation exposes the mask pattern onto a layer of resist formed on the substrate. The resist is then developed so as to remove either the exposed portions of resist for a positive resist or the unexposed portions of resist for a negative resist. This forms a resist pattern on the substrate. A mask typically may comprise a transparent plate (e.g. of fused silica) having opaque (chrome) elements on the plate used to define a pattern. A radiation source illuminates the mask according to well-known methods. The radiation traversing the mask and the projection optics of the lithographic apparatus forms a diffraction-limited latent image of the mask features on the photoresist. This can then be used in subsequent fabrication processes, such as deposition, etching, or ion implantation processes, to form integrated circuits and other devices having very small features.

As semiconductor manufacturing advances to ultra-large scale integration (ULSI), the devices on semiconductor

wafers shrink to sub-micron dimension and the circuit density increases to several million transistors per die. In order to accomplish this high device packing density, smaller and smaller feature sizes are required. This may include the width and spacing of interconnecting lines and the surface geometry such as corners and edges of various features.

As the nominal minimum feature sizes continue to decrease, control of the variability of these feature sizes becomes more critical. For example, the sensitivity of given critical dimensions of patterned features to exposure tool and mask manufacturing imperfections as well as resist and thin film process variability is becoming more significant. In order to continue to develop manufacturable processes in light of the limited ability to reduce the variability of exposure tool and mask manufacturing parameters, it is desirable to reduce the sensitivity of critical dimensions of patterned features to these parameters.

As feature sizes decrease, semiconductor devices are typically less expensive to manufacture and have higher performance. In order to produce smaller feature sizes, an exposure tool having adequate resolution and depth of focus at least as deep as the thickness of the photoresist layer is desired. For exposure tools that use conventional or oblique illumination, better resolution can be achieved by lowering the wavelength of the exposing radiation or by increasing the numerical aperture of the lithographic exposure apparatus.

The skilled artisan will appreciate that the resolution varies in proportion to the exposure wavelength and varies in inverse proportion to the numerical aperture (NA) of the projection optical system. The NA is a measure of a lens' capability to collect diffracted radiation from a mask and project it onto the wafer. The resolution limit R (nm) in a photolithography technique using a reduction exposure method is described by the following equation:

$$R = k_1 \lambda / (NA)$$

where:

λ is the wavelength (nm) of the exposure radiation;

NA is the numerical aperture of the lens; and

k_1 is a constant dependent inter alia on the type of resist used.

It follows that one way to increase the resolution limit is to increase the numerical aperture (high NA). This method, however, has drawbacks due to an attendant decrease in the depth of focus, difficulty in the design of lenses, and complexity in the lens fabrication technology itself. An alternative approach is to decrease the wavelength of the exposure radiation in order to form finer patterns, e.g. to support an increase in the integration density of LSI (Large Scale Integration) devices. For example, a 1-Gbit DRAM requires a 0.2-micrometer pattern while a 4-Gbit DRAM requires a 0.1-micrometer pattern. In order to realize these patterns, exposure radiation having shorter wavelength can be used.

However, because of increased semiconductor device complexity that results in increased pattern complexity, and increased pattern packing density on a mask, distance between any two opaque mask areas has decreased. By decreasing the distances between the opaque areas, small apertures are formed which diffract the radiation that passes through the apertures. The diffracted radiation results in effects that tend to spread or to bend the radiation as it passes, so that the space between the two opaque areas is not resolved; in this way, diffraction is a severe limiting factor for optical photolithography.

A conventional method of dealing with diffraction effects in optical photolithography concerns the use of a phase shift mask, which replaces the previously discussed mask. Generally, with radiation being thought of as a wave, phase shifting is a change in timing (phase) of a regular sinusoidal pattern of radiation waves that propagate through a transparent material. Although the rest of this discussion will generally concentrate on transmissive phase shift masks, it should be realized that reflective phase shift masks can also be contemplated (e.g. for use with the wavelengths associated with EUV radiation). The current invention encompasses both these concepts.

Typically, phase-shifting is achieved by passing radiation through areas of a transparent material of either differing thickness or through materials with different refractive indexes, or both, thereby changing the phase or the periodic pattern of the radiation wave. Phase shift masks reduce diffraction effects by combining both diffracted radiation and phase-shifted diffracted radiation so that constructive and destructive interference takes place favorably. On the average, a minimum width of a pattern resolved by using a phase shifting mask is about half the width of a pattern resolved by using an ordinary mask.

There are several different types of phase shift structures. These types include:

alternating aperture phase shift structures, sub-resolution phase shift structures, rim phase shift structures, and chromeless phase shift structures. "Alternating Phase Shifting" is a spatial frequency reduction concept characterized by a pattern of features alternately covered by a phase shifting layer. "Sub-resolution Phase Shifting" promotes edge intensity cut-off by placing a sub-resolution feature adjacent to a primary feature and covering it with a phase shifting layer. "Rim Phase Shifting" overhangs a phase shifter over a chrome mask pattern.

In the case of transmissive masks, these phase shift structures are generally constructed in masks having three distinct layers of material. An opaque layer is patterned to form blocking areas that allow none of the exposure radiation to pass through. A transparent layer, typically the substrate plate (e.g. of quartz or calcium fluoride), is patterned with transmissive areas, which allow close to 100% of the exposure radiation to pass through. A phase shift layer is patterned with phase shift areas which allow close to 100% of the exposure radiation to pass through, but phase-shifted by 180° (π). The transmissive and phase-shifting areas are situated such that exposure radiation diffracted through each area is canceled out in a darkened area therebetween. This creates the pattern of dark and bright areas, which can be used to clearly delineate features. These features are typically defined by the opaque layer (i.e. opaque features) or by openings in the opaque layer (i.e. clear features).

For semiconductor (and other device) manufacture, alternating aperture phase shift masks may typically be used where there are a number of pairs of closely packed opaque features. However, in situations where a feature is too far away from an adjacent feature to provide phase shifting, sub-resolution phase shift structures typically may be employed. Sub-resolution phase shift structures typically may be used for isolated features such as contact holes and line openings, wherein the phase shift structures may include assist-slots or outrigger structures on the sides of a feature. Sub-resolution phase shift structures are below the resolution limit of the lithographic system and therefore do not print on the substrate. One shortcoming of sub-resolution phase shift structures is that they require a relatively large amount of real estate on the mask.

Rim phase shifting masks include phase shift structures that are formed at the rim of features defined by opaque areas of the mask. One problem with rim phase shift structures is that they are difficult to manufacture. In the case of rim phase shift structures, multiple lithographic steps must be used to uncover the opaque layer so that it can be etched away in the area of the rim phase shifter. This step is difficult, as the resist used in the lithographic step covers not only the opaque layer but also trenches etched into the substrate.

In general, improvement of the integration density of semiconductor integrated circuits in recent years has been achieved mainly through a reduction in size of the various circuit patterns. These circuit patterns are presently formed mainly by lithography processes using a wafer stepper or step-and-scan apparatus.

FIG. 1 shows the structure of such a prior art lithographic apparatus. Mask 108 is illuminated by the radiation emitted from illumination system 102. An image of mask 108 is projected onto a photoresist film coated on wafer 120, which is the substrate to be exposed through projection system 110. As shown in FIG. 1, illumination system 102 includes a source 100, condenser lens 104, and aperture 106 for specifying the shape and size of the effective source. Projection system 110 includes a projection lens 112, pupil filter 114, and aperture 116 arranged in or near the pupil plane of focussing lens 118 to set the numerical aperture (NA) of the lens.

As discussed earlier, the minimum features size R of patterns transferable by an optical system is approximately proportional to the wavelength λ of the radiation used for exposure and inversely proportional to the numerical aperture (NA) of the projection optical system. Therefore, R is expressed as $R=k_1 \lambda/NA$, where k_1 is an empirical constant and $k_1=0.61$ is referred to as the Rayleigh limit.

In general, when the pattern dimensions approach the Rayleigh limit, the projected image is no longer a faithful reproduction of the mask pattern shape. This phenomenon is caused by so-called optical proximity effects (OPEs) and results in corner rounding, line-end shortening, and line width errors, among other things. To solve this problem, algorithms have been proposed that can be used to predistort the mask pattern so that the shape of a projected image takes on the desired shape.

Moreover, approaches have been described which improve the resolution limit of a given optical system, resulting effectively in a decreased value of k_1 . Adoption of a phase shifting mask, such as described above, is a typical example of this approach. A phase shifting mask is used to provide a phase difference between adjacent apertures of a conventional mask.

A chromeless phase shifting mask method is known as a phase shifting method suitable for the transfer of a fine isolated opaque line pattern, which is needed, for example, for the gate pattern of a logic LSI device.

Off-axis illumination and pupil filtering are methods additionally known for improving images. According to the off-axis illumination method, the transmittance of aperture 106 is modified in the illumination system 102 of FIG. 1 (prior art). One particular embodiment of this method changes the illumination intensity profile so that the transmittance at the margin becomes larger than that of the central portion, which is particularly effective to improve the resolution of a periodic pattern, as well as the depth of focus. The pupil filtering method is a method of performing exposure through a filter (pupil filter) located at the pupil position of a projection lens to locally change the amplitude

and/or phase of the transmitted radiation. For example, this approach makes it possible to greatly increase the depth of focus of an isolated pattern. Furthermore, it is well known that the resolution of a periodic pattern can further be improved by combining the off-axis illumination method and the pupil filtering method.

Nonetheless, an inherent problem with a conventional transmission mask, such as the ones described above, is that the mask substrate (plate) generally undergoes a decrease in transmissivity as the wavelength of radiation emitted from an exposure radiation source is decreased so as to obtain finer patterns. For example, a quartz material substrate becomes more opaque as the wavelength of the radiation source decreases, particularly when the wavelength is less than 200 nm. This decrease in transmissivity affects the ability to obtain finer resolution patterns. For this reason, a material for a transmission phase shifting mask that can obtain a high transmissivity with respect to radiation having a short wavelength is needed. It is, however, difficult to find or manufacture such a material having a high transmissivity with respect to short-wavelength exposure radiation.

An example of a photomask pattern is shown in FIG. 2 (prior art). Passage of radiation around the illustrated features causes diffraction of the radiation into discrete dark and bright areas. The bright areas are known as the diffraction orders and the collective pattern they form is mathematically describable by taking the Fourier transform of the collective opaque and transparent regions. The pattern that is observed in its simplest personification has an intense diffraction order, called the 0th order, surrounded in a symmetrical fashion by less intense diffraction orders. These less intense orders are called the plus/minus first ($\pm 1^{st}$) order; plus/minus second ($\pm 2^{nd}$) order; and so on into an infinity of orders. For the same feature width, different diffraction patterns are formed for dense and isolated features. FIG. 3(A) (prior art) shows the magnitudes of relative electric fields and respectively pupil positions (X) of diffraction orders for a dense feature, while FIG. 3(B) (prior art) shows the magnitudes of diffraction orders for an isolated one. The center peak observed in each plot is the 0th order.

The 0th order contains no information about the pattern from which it arose. The information about the pattern is contained in the non-zero orders. However, the 0th order is spatially coherent with the higher orders so that, when the beams are redirected to a point of focus, they interfere, and in doing so construct an image of the original pattern of opaque and transparent objects. If all the diffraction orders are collected, a perfect representation of the starting object is obtained. However, in high-resolution lithography of small-pitch features, where pitch is the sum of the width of the opaque and transparent objects, only the 0th and the $\pm 1^{st}$ orders are collected by the projection lens to form the image. This is because higher orders are diffracted at higher angles that fall outside of the lens pupil as defined by the numerical aperture (NA).

As depicted in FIG. 4(A) (prior art), the 0th order 402 and the $\pm 1^{st}$ orders 404 lie within the lens pupil 406. As further depicted in FIG. 4(A), the $\pm 2^{nd}$ orders 408, lie outside the lens pupil 406. Further, as seen in FIG. 4(B) (prior art), a corresponding aerial image is formed during exposure (I indicates intensity, and H indicates horizontal position). The photoresist pattern is then delineated from this aerial image.

It has long been known that it is only necessary to collect two diffraction orders, such as either with the 0th order and at least one of the higher diffraction orders, or simply two higher orders without the 0th order, to form the image.

As depicted in FIG. 5(A) (prior art), radiation transmitted through a focussing lens 502 is represented by that which is

normal **504** to the object (not shown), and that which transmits through the edges **506**, **508** of the focussing lens **502**. Although radiation is continuously transmitted throughout the entire surface of lens **502**, the three radiation paths **504-508** are represented to illustrate phase matching of different radiation paths. At point **510**, the three radiation paths **504-508** focus and are in phase together. When the three radiation paths **504**, **512**, and **514** focus together at point **516**, however, they are not in phase.

The phase error from a change in path-lengths of **512** and **514** from respective path-lengths **506** and **508** results in a finite depth of focus, DoF, of the system.

One may improve the tolerance to variations in relative phase error caused by aberrations like defocus as depicted in FIG. **5(A)**. FIG. **5(B)** (prior art) represents how, by eliminating the radiation path that is normal to the object, variations to the phase error may be reduced. Again, although radiation is continuously transmitted throughout the surface of lens **502**, the two radiation paths **506** and **508** are represented to illustrate phase matching of different radiation paths. At point **510**, the two radiation paths **506** and **508** focus and are in phase together. When the two radiation paths **512** and **514** focus together at point **516**, they are in phase. Without the radiation path **504** as seen in FIG. **5(A)**, the phase error from the increased path-lengths of **512** and **514** over respective path-lengths **506** and **508** is eliminated, resulting in an infinite depth of focus, DoF, of the system. Eliminating the radiation path normal to the object may be accomplished by placing an obscuration in the center of the radiation source, thus eliminating radiation normal to the object and allowing only oblique illumination, as depicted for example in FIG. **6(A)**.

FIG. **6(A)** (prior art) depicts a lithographic "on-axis" projection system ("C" indicates conventional) wherein the illumination configuration **602** is such as to permit transmission of radiation normal to the object. In the figure, radiation passes through the reticle, comprising a quartz substrate **604** and chrome patterns **606**, through the lens aperture **608**, into lens **610**, and is focused into area **612**. FIG. **6(B)** (prior art) depicts exemplary lithographic "off-axis" projection systems wherein an annular (A) illumination configuration **614**, or quadrupole (Q) illumination configuration **616**, prohibits transmission of radiation normal to the object. In the figure, radiation passes through the vitreous substrate **604**, past the chrome patterns **606**, through the lens aperture **608**, into lens **610**, and is focused into area **618**. Comparing FIGS. **6(A)** and **6(B)**, it is noted that the Depth of Focus (DoF) of FIG. **6(A)** is smaller than that of FIG. **6(B)**.

Lowering the 0^{th} order's magnitude to be the same as or less than that of the 1^{st} order improves the imaging tolerance of this two-beam imaging system. One method for tuning the magnitude of the diffraction orders is to use weak phase shift masks. Strong phase shift masks and weak phase shift masks differ in operation and effect.

Strong phase shift masks eliminate the zero-diffraction order and double the resolution through a technique of frequency doubling. To understand how strong phase shifters work, it is useful to think of the critical pitch as having alternating clear areas adjacent to the main opaque feature. Because of the alternating phase regions, the pitch between same-phase regions is doubled. This doubling halves the position at which the diffraction orders would otherwise pass through the projection lens relative to the critical pitch, thus making it possible to image features with half the pitch allowed by conventional imaging. When the two opposing phase regions add through destructive

interference, to build the final image, their respective zero-order radiation is equal in magnitude but of opposite phase, thus canceling. Imaging is done only with the frequency-doubled higher orders. On the other hand, weak phase shift masks dampen the zero-order radiation and enhance the higher orders. Weak phase shift masks from their phase shift between adjacent features by creating electric fields of unequal magnitude and of opposite phase, with the field immediately adjacent to a critical feature having the lesser of the magnitudes. The net electric field reduces the magnitude of the zero order while maintaining the appropriate phase.

Weak phase shift masks permit an amount of exposure radiation to pass through objects in a fashion that creates a difference in phase between coherently linked points while having an imbalance in the electric field between the shifted regions. FIG. **7(A)** (prior art) depicts a substrate **702** and a mask pattern **704** that does not permit phase shifting. FIG. **7(C)** (prior art) is a graph illustrating how the 0^{th} order's magnitude is larger than that of the $\pm 1^{st}$ orders' magnitude from a non-phase shifting mask as depicted in FIG. **7(A)**. FIG. **7(B)** (prior art) depicts a substrate **702** and a mask pattern **706** that permit phase shifting (in the Figure, Φ is phase, t is thickness, n is index of refraction and λ is wavelength). FIG. **7(D)** (prior art) is a graph illustrating how the 0^{th} order's magnitude is decreased to be comparable to that of the $\pm 1^{st}$ orders' magnitude from a phase shifting mask as depicted in FIG. **7(B)**.

Several types of phase-shifting masks are known in the art, such as the rim, attenuated or embedded (or incorrectly halftone), and unattenuated or chromeless (or transparent) shifter-shutter phase-shifting masks.

FIG. **8(A)** (prior art) is a cross-sectional view of a rim phase-shifting mask **802**, comprising radiation transmitting portions **804**, and radiation inhibiting portions **806**. FIG. **8(B)** (prior art) is a graph representing the amplitude (E) of the E-field at the mask, whereas FIG. **8(C)** (prior art) is a diagram representing the magnitude of the 0^{th} diffraction order **810**, and $\pm 1^{st}$ orders **812**, **814**, resulting from use of the mask depicted in FIG. **8(A)**.

FIG. **9(A)** (prior art) is a cross-sectional view of an attenuated or embedded phase-shifting mask **902** having an attenuation of 5%, comprising a radiation attenuating portion **904**. FIG. **9(B)** (prior art) is a graph representing the amplitude of the E-field at the mask, whereas FIG. **9(C)** (prior art) is a diagram representing the magnitude of the 0^{th} diffraction order, and $\pm 1^{st}$ diffraction orders resulting from use of the mask depicted in FIG. **9(A)**. FIG. **9(D)** (prior art) is a cross-sectional view of an attenuated or embedded phase-shifting mask **912** having an attenuation of 10%, comprising a radiation attenuating portion **914**. FIG. **9(E)** (prior art) is a graph representing the amplitude of the E-field at the mask, whereas FIG. **9(F)** (prior art) is a diagram representing the magnitude of the 0^{th} diffraction order, and $\pm 1^{st}$ diffraction orders resulting from use of the mask depicted in FIG. **9(D)**.

FIG. **10(A)** (prior art) is a cross-sectional view of an unattenuated or chromeless (or transparent) shifter-shutter phase-shifting mask **1002**, comprising a radiation-shifting portion **1004**. FIG. **10(B)** (prior art) is a graph representing the amplitude of the E-field at the mask, whereas FIG. **10(C)** (prior art) is a diagram representing the magnitude of the 0^{th} diffraction order **1006**, and $\pm 1^{st}$ diffraction orders **1008**, **1010** resulting from use of the mask depicted in FIG. **10(A)**.

Typically, the phase-shifting masks of FIG. **8** through FIG. **10** form their phase-shift differently, but, relative to their non-phase-shifted counterpart, they all yield a 0^{th} diffraction order of smaller amplitude and a first diffraction

order of larger amplitude, as regards electric field. Which ratio of 1st to 0th diffraction order magnitude is optimal depends on the pitch of the feature being imaged, along with the shape of the illumination configuration and the desired printing size in the developed photoresist. These tuned diffraction patterns are then used with off-axis illumination to image smaller pitches with better tolerance to imaging process variation.

The concept of manipulation of the amplitude ratio of 0th to 1st diffraction orders has conventionally been restricted to using certain weak phase-shifting techniques with biasing features and sub-resolution assist features.

FIG. 11(A) (prior art) depicts a conventional biasing technique used to resolve a desired feature. As seen in FIG. 11(A), biasing (B) bars 1102 and 1104 are situated adjacent the mask of the primary feature 1106. FIG. 11(B) depicts a half-tone biasing (HB) technique known to the applicants of the instant application and described in U.S. Pat. No. 6,114,071 (incorporated herein by reference), used to resolve a desired feature. As seen in FIG. 11(B), half-tone biasing bars 1108 and 1110 are situated adjacent the mask of the desired feature 1112. FIG. 12 (prior art) depicts a conventional photoresist mask 1202. The photoresist mask 1202 comprises a plurality of scatter bars 1204, serifs 1206, and chrome shields 1208.

For conventional attenuated phase shifters, transparency of the shifter materials typically may be adjusted, and used along with biasing and sub-resolution assist features. Transparency of the shifters typically ranges from 3% to 10%, wherein higher transmissions such as from 10% to 100% are reported to be optimal for pitches where the space between the features is larger than the phase-shifted line. FIG. 13 (prior art) shows the dependence of image contrast, as defined by the Normalized Image Log Slope (NILS), with respect to varying transmittance (T) of its phase-shifted material for a 175 nm line on a 525 nm pitch (FIG. 13A) and a 1050 nm pitch (FIG. 13B). Each curve in the figure represents a different focus (F) setting. The curve with the largest NILS is the most focussed, and has an F-value of zero; further, with each change in focus, the NILS of each respective curve decreases. FIG. 13A shows that the best transmission for the 175 nm line with the 525 nm pitch structure is 0.35 to 0.45. FIG. 13B shows that the best transmission for the 175 nm line with the 1050 nm pitch structure is 0.25 to 0.35.

An example of a 100% transparent attenuated phase-shifting technology is the previously mentioned, chromeless shifter-shutter, such as depicted in FIG. 10. Using a chromeless shifter-shutter, phase-edges of a pattern typically may be placed within an area that is 0.2 to 0.3 times the exposing wavelength λ divided by the numerical aperture NA of the projection lens. For lines larger or smaller than this, the destructive interference is insufficient to prevent exposure in an area not be exposed. Printing features larger than this is accomplished in one of two ways. The first places an opaque layer in the region that is to stay dark with the feature edges being opaque or rim-shifted (FIG. 14; prior art). The second, as depicted in FIG. 15 (prior art), creates a dark grating 1502 by placing a series of features 1504 whose size meets the criteria for printing an opaque line 1506 using chromeless technology. In FIGS. 14 and 15, "IM" denotes image, "CPSM" denotes a chromeless phase shift mask, "OP" indicates opaque and "PS" denotes phase shift.

Conventionally, chromeless phase shifting masks have not worked with off-axis exposure as the shifter (feature) sizes and shutter (space) sizes approach one another. FIGS. 16(A) through 16(C) depict a conventional chromeless

phase shifting mask. In FIG. 16(A) (prior art), 1602 is a cross-sectional view of a portion of a conventional chromeless phase shifting mask, comprising shifters 1604, and shutters 1606, wherein the shifter length is substantially equal to the shutter length. FIG. 16(B) (prior art) is a graph representing the amplitude of the E-field at the mask 1602. FIG. 16(C) (prior art) is a diagram representing the magnitudes of the $\pm 1^{\text{st}}$ diffraction orders 1608 and 1601 for the mask of FIG. 16(A). As seen in FIG. 16(C) there is no 0th diffraction order. The functional limit of the relative sizes of the shifter and shutters of conventional chromeless phase shifting masks results from the integrated electric fields of the two opposing phase-shifted regions being equal. This balanced condition cancels the 0th diffraction order, making it impossible to get the prerequisite 0th diffraction order needed for using off-axis illumination.

To summarize, each of the above-described, conventional, weak phase-shifting techniques solves certain imaging problems. However, each technique has accompanying drawbacks. For example, the rim, attenuated or embedded, and unattenuated or chromeless (or transparent) shifter-shutter phase-shifting masks provide large ratios of the 0th to $\pm 1^{\text{st}}$ diffraction orders. Prior-art attempts to manipulate these ratios include using biasing techniques coupled with an attenuated phase shifting mask. However, these prior art attempts include complex manufacturing steps and yield inefficient masks as a result of the attenuation. Furthermore, unattenuated shifter-shutter phase-shifting mask additionally fail to yield accurate images with off-axis illumination as the shifter and shutter sizes approached one another.

SUMMARY OF THE INVENTION

It is an object of this invention to provide a simple system and method for fabricating an efficient phase shifting mask that is able to manipulate the ratios of the 0th to $\pm 1^{\text{st}}$ diffraction orders.

It is another object of this invention to provide a system and method for fabricating a non-attenuated phase shifting mask that is able to manipulate the ratios of the 0th to 1st diffraction orders.

It is yet another object of this invention to provide a system and method for fabricating a chromeless (or transparent) shifter-shutter phase-shifting mask that is usable with off-axis illumination when the shifter and shutter sizes approach one another.

It is still another object of this invention to provide a system and method for halftoning primary features to achieve the correct ratio of 0th to higher diffraction order radiation for optimal imaging.

It is yet another object of this invention to provide a system and method for halftoning assist features to achieve the correct ratio of 0th to higher diffraction order radiation for optimal imaging.

The present invention provides an alternate method for effectively manipulating the amplitude ratio of the 0th to 1st diffraction order by using halftoning of opaque and phase-shifted transparent/semi-transparent features within the primary feature and as sub-resolution assist features. The relative magnitudes of the 0th and higher diffraction orders are formed as the exposing wavelength passes through the plurality of zero and 180° phase-shifted regions. Subsequently, some of the diffraction orders are collected and projected to form the image of the object.

Methods in accordance with the present invention further make use of halftoning structures to manipulate the relative magnitudes of diffraction orders to ultimately construct the

desired projected image. At the resolution limit of the mask marker, this is especially useful for converting strong-shifted, no-0th-diffraction-order, equal-line-and-space chromeless phase edges to weak phase shifters that have some 0th order. Halftoning creates an imbalance in the electric field between the shifted regions, and therefore results in the introduction of the 0th diffraction order. As such, with halftoning, these previously strong-shifted features convert to weak phase-shifters and are compatible with the other shifter-shutter chromeless features typically found amongst the plurality of objects used in making a conventional semiconductor circuit.

Decreasing the size of the primary feature for the very dense features, as in the conventional mask fabrication technique, can achieve a limited extent of modifying diffraction order. Because of the interference effects, it is not possible to ensure that a mask width less than the sub-resolution assist feature can be reliably made using conventional mask fabrication methods. However, in accordance with the present invention, by biasing the primary features, the feature width can be reduced to less than the sub-resolution assist features.

Further, use of a chromeless phase-shifting mask is known to be a powerful imaging method when combined with using off-axis illumination, but it has serious optical proximity effects. This invention provides an effective optical proximity solution.

In general, in one aspect, the invention features a method of transferring an image, including 0th diffraction order and $\pm 1^{st}$ diffraction orders, onto a material, wherein the method comprises the steps of fabricating a phase shifting mask comprising at least one unattenuated, halftoned, phase-shift feature, and off-axis illuminating the mask such that radiation passes through the mask onto the material.

In another aspect, the invention features a method of transferring an image, including 0th diffraction order and $\pm 1^{st}$ diffraction orders, onto a material, wherein the method comprises the steps of fabricating a phase shifting mask comprising at least one feature, said at least one feature including halftoned phase-shifted transparent features; and off-axis illuminating the mask such that radiation passes through the mask onto the material. Preferably, said one feature further includes semi/transparent features. Further, said at least one feature preferably includes opaque features.

In yet another aspect, the invention features a phase shifting mask comprising at least two unattenuated, halftoned, phase-shift features having a width w , wherein the features are separated by a width w , such that the mask provides an image including 0th diffraction order and $\pm 1^{st}$ diffraction orders, when illuminated.

In still yet another aspect, the invention features a phase shifting mask comprising at least two halftoned phase-shifted transparent features having a width w , wherein the features are separated by a width w , such that the mask provides an image including 0th diffraction order and $\pm 1^{st}$ diffraction orders, when illuminated. Preferably, the at least two features further includes semi/transparent features. Still preferably, the at least two features further includes opaque features. Even more preferably, a focus-exposure process window for maintaining a predetermined resist line-width sizing of the mask is common to an attenuated, phase-shift mask of a similar pitch.

As described in further detail below, the present invention provides significant advantages over the prior art. Most importantly, the unattenuated phase-shift photomask of the present invention allows for the printing of high-resolution

features, while manipulating the 0th diffraction order and $\pm 1^{st}$ diffraction orders.

In addition, the unattenuated phase-shift mask of the present invention provides a focus-exposure process window for maintaining an increased line-width sizing over that of the prior art.

Additional advantages of the present invention will become apparent to those skilled in the art from the following detailed description of exemplary embodiments of the present invention. The invention itself, together with further objects and advantages, can be better understood by reference to the following detailed description and the accompanying schematic drawings.

BRIEF DESCRIPTION OF THE DRAWINGS

The accompanying schematic drawings, which are incorporated in and form a part of the specification, illustrate embodiments of the present invention and, together with the description, serve to explain the principles of the invention. In the drawings:

FIG. 1 depicts a prior-art wafer stepper system.

FIG. 2 depicts a photomask pattern provided with optical proximity correction features such as scattering bars and serifs.

FIG. 3(A) depicts a diffraction spectrum for equal lines and spaces. FIG. 3(B) depicts a diffraction spectrum for an isolated line.

FIG. 4(A) depicts a diffraction spectrum of objects whose size is near the wavelength of the exposing energy. FIG. 4(B) depicts an aerial image of the diffraction spectrum of FIG. 4(A).

FIG. 5(A) depicts the effects of three-beam exposure in a conventional mask fabrication system. FIG. 5(B) depicts the effects of two-beam exposure in a convention mask fabrication system.

FIG. 6(A) depicts a conventional on-axis exposure technique for mask fabrication. FIG. 6(B) depicts conventional off-axis exposure techniques for mask fabrication, wherein the illumination configuration has an annular shape, or a quadrupole shape.

FIG. 7(A) depicts a cross-sectional view of a conventional non-phase shifting mask. FIG. 7(B) depicts a cross-sectional view of a conventional phase shifting mask. FIG. 7(C) depicts the corresponding diffraction spectrum for the conventional non-phase shifting mask of FIG. 7(A). FIG. 7(D) depicts the corresponding diffraction spectrum for the conventional phase shifting mask of FIG. 7(C).

FIG. 8(A) depicts a cross-sectional view of a conventional rim-type phase shifting mask. FIG. 8(B) depicts a graph of the amplitude of the electric field at the conventional rim-type phase shifting mask of FIG. 8(A). FIG. 8(C) depicts the corresponding diffraction spectrum for the conventional rim-type phase shifting mask of FIG. 8(A).

FIG. 9(A) depicts a cross-sectional view of a conventional attenuated-type phase shifting mask, having an attenuation factor of 5%. FIG. 9(B) depicts a graph of the amplitude of the electric field at the conventional attenuation-type phase shifting mask of FIG. 9(A). FIG. 9(C) depicts the corresponding diffraction spectrum for the conventional attenuation-type phase shifting mask of FIG. 9(A). FIG. 9(D) depicts a cross-sectional view of a conventional attenuated-type phase shifting mask, having an attenuation factor of 10%. FIG. 9(E) depicts a graph of the amplitude of the electric field at the conventional attenuation-type phase shifting mask of FIG. 9(D). FIG. 9(F) depicts the corre-

sponding diffraction spectrum for the conventional attenuation-type phase shifting mask of FIG. 9(D).

FIG. 10(A) depicts a cross-sectional view of a conventional transparent or chromeless shifter-shutter-type phase shifting mask. FIG. 10(B) depicts a graph of the amplitude of the electric field at the conventional transparent or chromeless shifter-shutter-type phase shifting mask of FIG. 10(A). FIG. 10(C) depicts the corresponding diffraction spectrum for the conventional transparent or chromeless shifter-shutter-type phase shifting mask of FIG. 10(A).

FIG. 11(A) depicts a conventional biased photomask. FIG. 11(B) depicts a halftone biased photomask.

FIG. 12 depicts a conventional, attenuated phase-shifting, lithographic mask.

FIGS. 13(A) and 13(B) graphically depict image contrast as a function of transmittance (T), for different pitches and focus settings.

FIG. 14(A) depicts a conventional opaque feature and its corresponding image. FIG. 14(B) depicts a conventional rim-shifted opaque feature and its corresponding image.

FIG. 15 depicts a conventional chromeless dark grating as an opaque feature, and its corresponding image.

FIG. 16(A) depicts a cross-sectional view of a conventional chromeless phase-edge mask. FIG. 16(B) depicts a graph of the amplitude of the electric field at the conventional transparent or chromeless phase-edge mask of FIG. 16(A). FIG. 16(C) depicts the corresponding diffraction spectrum for the conventional chromeless phase-edge mask of FIG. 16(A).

FIG. 17(A) depicts a primary feature in a phase-edge mask. FIG. 17(C) depicts the corresponding diffraction spectrum for the phase-edge mask of FIG. 17(A). FIG. 17(B) depicts a halftone primary feature in a phase-edge mask in accordance with the present invention. FIG. 17(D) depicts the corresponding diffraction spectrum for the phase-edge mask of FIG. 17(C).

FIG. 18 depicts a halftone scattering bar assist feature in accordance with the present invention.

FIG. 19(A) is a diagram depicting simulated resist images for a plurality of conditions of pitch and transmission. FIG. 19(B) is a graphical representation of the data represented in FIG. 19(A). FIG. 19(C) is a contour plot showing the set of exposure dose (vertical axis) and focus (horizontal axis) conditions to size a 100 nm resist image between 90 nm and 110 nm. The two process windows in FIG. 19C are for a 400 nm pitch (upper contour) and for a 600 nm pitch (lower contour). These process windows do not overlap. FIG. 19D is a different analysis of the same information shown in FIG. 19C. FIG. 19D illustrates how much exposure latitude (vertical axis) there is within a process window for a certain depth of focus (horizontal axis). In FIG. 19D, the top curve is for the 400 nm pitch and the lower curve is for the 600 nm pitch.

FIG. 20(A) depicts layout for a 26% transmittance attenuated phase-shifting mask. FIG. 20(B) depicts a layout for an unattenuated, chromeless phase-shifting mask that has been halftoned, in accordance with the present invention, to make its diffraction pattern similar to that of the 26% attenuated mask of FIG. 20(A). FIG. 20(C) is a graphical comparison of the diffraction orders produced by the mask of FIG. 20(A) and the mask of FIG. 20(B). FIG. 20(D) is an aerial image of a portion of the pattern of the mask of FIG. 20(B). FIG. 20(E) is a graphical representation of the focus-exposure process window for maintaining a specified line-width sizing for the mask of FIG. 20(A). FIG. 20(F) is a graphical

representation of the focus-exposure process window for maintaining a specified line-width sizing for the mask of FIG. 20(B). FIG. 20(G) is a graphical representation of the percent exposure latitude for both masks of FIG. 20(A) and FIG. 20(B) respectively. FIG. 20(H) is an alternative graphical representation of the percent exposure latitude for both masks of FIG. 20(A) and FIG. 20(B), respectively.

FIGS. 21(A) and 21(B) depict conventional chromeless phase-shift patterns. FIGS. 21(C) and 21(D) depict halftone chromeless phase-shift patterns in accordance with the present invention, corresponding to the phase-shift patterns of FIGS. 21(A) and 21(B) respectively. FIGS. 21(E) through 21(H) depict diffraction patterns (graphs of the diffraction orders) for the object pattern of the phase-shift masks of FIGS. 21(A) through 21(D) respectively. FIG. 21(I) shows the focus-exposure process windows for a 100 nm line with pitches of 400 nm (2134 and 2132) and 600 nm (2130) for masks that used the appropriate halftoning (FIG. 21D for the 400 nm pitch and FIG. 21C for the 600 nm pitch) to make the features size with similar exposure and focus. For the 400 nm pitch the total process window includes areas 2134 and 2132, with 2134 overlapping with the 600 nm pitch process window, 2130. FIG. 21J shows the exposure latitude for varying amounts of depth of focus for the common focus-exposure area 2134.

FIG. 22(A) depicts a diffraction pattern for the object pattern of a conventional phase-shift mask. FIG. 22(B) depicts a diffraction pattern for the object pattern of a halftone phase-shift mask in accordance with the present invention. FIG. 22(C) is a graphical representation of the focus-exposure process window for maintaining a specified line-width sizing for the mask of FIG. 22(A). FIG. 22(D) is a graphical representation of the focus-exposure process window for maintaining a specified line-width sizing for the mask of FIG. 22(B).

FIG. 23(A) depicts a global layout of a conventional primary feature. FIG. 23(B) depicts a global layout of a halftone primary feature in accordance with the present invention. FIG. 23(C) is an aerial image of the global layout of FIG. 23(A). FIG. 23(D) is an aerial image of the global layout of FIG. 23(B). FIG. 23(E) is a magnified portion of FIG. 23(C). FIG. 23(F) is a magnified portion of FIG. 23(D).

FIG. 24 is a logic flow diagram describing a method for designing patterns that emulate different phase-shift masks in accordance with the present invention.

FIG. 25 depicts a lithographic projection apparatus.

In the Figures, like reference symbols indicate like parts.

DETAILED DESCRIPTION OF THE INVENTION

In the following description, for the purposes of explanation, numerous specific details are set forth in order to provide a more thorough understanding of the present invention. It will be apparent, however, to one skilled in the art that the present invention may be practiced without these specific details.

Specifically, the following detailed description of the unattenuated phase-shift mask of the present invention relates to both the mask itself as well as a method of forming the mask. It is noted that, in an effort to facilitate the understanding of the present invention, the following description details how the unattenuated phase-shift mask can be utilized to form features contained in today's state-of-the-art semiconductor devices. However, it is also noted that the present invention is not limited to use in semiconductor devices. Indeed, the present invention can be utilized

in a multitude of different types of designs and processes that include the projection of high-resolution images.

A first exemplary embodiment of the present invention includes halftoning primary features of a chromeless shifter shutter phase-shifting mask. FIG. 17 shows halftoning of a primary feature so that it has an optimal 0^{th} to $\pm 1^{st}$ diffraction order amplitude using a chromeless shifter-shutter phase-shifting mask. FIG. 17(A) shows primary features **1702** before halftoning, whereas FIG. 17(B) shows the primary features **1704** after halftoning. FIGS. 17(C) and 17(D) depict diffraction patterns of an equal line/space chromeless pattern to that of the respective structures in FIGS. 17(A) and 17(B). As seen in FIG. 17(C), without halftoning, there are $\pm 1^{st}$ diffraction orders **1706** and **1708**; however there is no 0^{th} diffraction order. On the other hand, as seen in FIG. 17(D), because of the halftoning of the primary features, thereby permitting off-axis illumination for these dense features, there are $\pm 1^{st}$ diffraction orders **1710**, **1712**, and there is a 0^{th} diffraction order **1714**. In the Figures, "CPE" denotes chromeless phase edge, and "HCPE" denotes halftone CPE.

A second exemplary embodiment of the present invention includes halftoning scattering bar assist features of a chromeless shifter-shutter phase-shifting mask. FIG. 18 depicts an example of a chromeless shifter-shutter phase-shifting mask **1802**, comprising halftoned scattering bar assist features **1804**, and primary features **1806**. Halftoning a scattering bar assist feature permits its associated primary feature to have an optimal 0^{th} to $\pm 1^{st}$ diffraction order amplitude using a chromeless shifter-shutter phase-shifting mask.

Examining features of varying pitch-size imaged using phase-shifting masks shows a pitch dependence on the transmission that is best suited to obtaining the same size of resist image for a given exposure condition. FIGS. 19(A) and 19(B) show—for 100 nm lines that are separated by spaces ranging in size from 100 nm to 800 nm—the transmission of the phase-shift required to produce a 100 nm line for each pitch.

More specifically, FIG. 19(A) shows the imaging result for different combinations of attenuated phase-shift mask transmittance and space sizes between 100 nm features. As seen in FIG. 19(A), Figures **1902** at the intersection of each condition of transmittance and space size are simulated cross-sections of developed photoresist images that were exposed at 22 mJ/cm² and -0.15 microns of focus using a 0.70 NA, 248 nm exposure tool with quadrupole illumination. The images **1904** surrounded by the boxes have a resist image size between 90 and 110 nm. These sizes are used here to arbitrarily derive the lower and upper limits for acceptable sizing. Images outside of the boxed areas do not meet this criterion. In the Figure, "PSM1T" denotes PSM Feature #1 Transmittance, and "PSM2W" denotes PSM Feature #2 Width. FIG. 19(B) is a graphical representation of the same data as represented in FIG. 19(A). As seen in FIGS. 19(A) and 19(B), in the range of 20 to 30% transmittance, the figures meet the sizing criteria of $\pm 10\%$ of 100 nm for the exposure condition of 22 Mj/cm² and -0.15 microns of focus, for 400 nm pitch sizes and 600 nm pitch sizes, each having a transmission of 100%.

FIG. 19(C) is a graph showing the focus-exposure process window for maintaining a specified line-width sizing for 600 nm and 400 nm pitch phase shift masks, each having 100% transmission. As seen in FIG. 19(C) the exposure dose (D) and focus (F) conditions for attaining 100 nm lines for 600 nm and 400 nm pitches are totally separate, with no common

process corridor. FIG. 19(D) is a graph showing exposure latitude (EL) versus the depth of focus (DoF) for 600 nm and 400 nm pitch phase shift masks, each having 100% transmission. The exposure latitude is the range of exposure that maintains $\pm 10\%$ feature sizing, divided by the exposure dose to size the feature, times 100. It is clear that as the exposure latitude decreases, the depth of focus increases for each pitch. However, as seen in FIG. 19(D), there is not a point in which both the 600 nm and 400 nm pitch phase shift mask share a common exposure latitude and corresponding depth of focus. As such, without correction in accordance with the present invention, a 600 nm and 400 nm pitch can not size a 100 nm resist line using the same conditions of exposure and focus.

FIGS. 19(A)-(D) represent simulated data corresponding to photomasks. Generally, 5-10% attenuated PSMs are conventionally available for commercial applications, whereas higher transmissions may be custom produced. As such, there are limited materials available to produce masks. Further, different pitch structures may not perform optimally on such limited-availability materials. Still further, one material would never be optimal for the plurality of structures occurring on a set of patterns found on a single conventional mask. Therefore, the present invention removes these barriers because the present invention provides a method of halftoning primary and assist features to emulate the diffraction pattern of any of the prior-art phase shifting masks. Specifically, the present invention permits different pitch structures to preform optimally on a single mask.

The following describes the invention method to solve the problem described with respect to FIGS. 19(A) through 19(D).

Halftoning may be used to permit an unattenuated, 100% chromeless mask to produce a diffraction pattern and resultant aerial image that emulate a diffraction pattern and resultant aerial image corresponding to a 26% transparent, attenuated phase-shift mask. This is a hypothetical example, because 26% attenuated material does not commercially exist in mass quantities. Nevertheless, it is an optimum transmission for some features and the present invention makes a halftoned chromeless phase-shift mask that matches the performance of the 26% attenuated material. As such, the optimum transmission is attainable without attenuating the image with the prior-art attenuated masks.

FIGS. 20(A) through 20(D) represent how an attenuated phase-shifting mask is fabricated from an unattenuated, chromeless phase-shifting mask in order to image, in this example, a 100 nm line of a 400 nm-pitch feature the same way as if an unattenuated, chromeless phase-shifting mask were used. FIG. 20(A) depicts a primary feature **2006** in a portion **2004** of a mask layout **2002** for a 26% transmittance attenuated phase-shifting mask. FIG. 20(B) depicts halftoning objects **2012** in a portion **2010** of a mask layout **2008** for an unattenuated, chromeless phase-shifting mask that has been halftoned, thereby rendering a diffraction pattern nearly perfectly similar to that of the 26% attenuated mask of FIG. 20(A). FIG. 20(C) is a graph comparing the diffraction orders produced by both portions **2004** and **2010** of the attenuated and the halftoned, unattenuated masks respectively (the overlap of the graphs resulting from the two different situations is substantially perfect); NA is the numerical aperture. FIG. 20(D) is an aerial image of the halftone mask of FIG. 20(B), wherein the aerial image shows no signs of the discrete halftoning objects.

FIGS. 20(E) and 20(F) illustrate graphs showing the focus-exposure process window for maintaining 90 nm to

110 nm resist line-width sizing in the 26% transmittance attenuated phase-shifting mask (attPSM) of FIG. 20(A), and the half-tone unattenuated, chromeless phase-shifting mask (HTPSM) of FIG. 20(B), respectively. FIG. 20(G) is a graphical representation of the focus-exposure process window for maintaining a specified line-width sizing for both masks of FIG. 20(A) and FIG. 20(B). As seen in FIG. 20(G), there is an overlapping portion (OV) of the graph for both masks of FIG. 20(A) and FIG. 20(B). Further, as seen in FIG. 20(H), the percent exposure latitude for both masks is relatively similar. Therefore, as evidenced by FIGS. 20(G) and 20(H), the half-tone unattenuated, chromeless phase-shifting mask of FIG. 20(B) may be used to emulate a 26% transmittance attenuated phase-shifting mask of FIG. 20(A).

In this exemplary embodiment, emulating a 26% attenuated-like phase-shift mask, such as depicted in FIG. 20(A), with a 100% chromeless phase-shift mask, such as depicted in FIG. 20(B), included increasing the width of the 100 nm line to 115 nm and half-toning the line using a 180-nm half-tone pitch (htp) with a 67% duty cycle of 180° shifter-to-non-shifter regions. The half-tone has a region that is shifted relative to a region that is not. In this exemplary embodiment, a 67% half-tone duty cycle means that 67%, or 120 nm, has been modified to be 180° phase-shifted, and 33%, or 60 nm, is an unmodified 0° reference area.

FIGS. 21(A) through 21(J) show how two features that have different optimal transmissions can be half-toned so that they have optimal imaging capability using the same attenuated phase-shifting material. FIG. 21(A) depicts a primary feature 2106 in a portion 2104 of a mask layout 2102 for a 600 nm pitch chromeless phase-shifting mask. FIG. 21(B) depicts a primary feature 2112 in a portion 2110 of a mask layout 2108 for a 400 nm pitch chromeless phase-shifting mask.

FIG. 21(C) depicts a primary feature 2118 and half-toning scatter bar 2120 in a portion 2116 of a mask layout 2114 for a 600 nm pitch unattenuated phase-shifting mask (CrSB denotes chrome scattering bar). The line-width of primary feature 2118 is increased over that of primary feature 2106 of FIG. 21(A). Similarly, FIG. 21(D) depicts a half-tone (HT) primary feature 2126 in a portion 2124 of a mask layout 2122 for a 400 nm pitch unattenuated phase-shifting mask, wherein the line-width of half-tone primary feature 2126 is increased over that of primary feature 2112 of FIG. 21(B). The masks depicted in FIG. 21(A) and FIG. 21(B) have been modified to result in the masks depicted in FIG. 21(C) and FIG. 21(D), respectively.

FIGS. 21(E) through 21(H) show the diffraction patterns corresponding to the mask patterns of FIGS. 21(A) through 21(D) respectively. FIG. 21(G) and FIG. 21(H) show the modified diffraction patterns corresponding to the mask patterns FIG. 21(C) and FIG. 21(D). As compared to the diffraction patterns illustrated in FIG. 21(E) and FIG. 21(F), the diffraction patterns are modified when the original mask patterns illustrated in FIG. 21(A) and FIG. 21(B) are modified to become the mask patterns illustrated in FIG. 21(C) and FIG. 21(D), respectively.

FIG. 21(I) shows that there is a common focus-exposure corridor for both mask patterns of FIGS. 21(C) and 21(D). As seen in FIG. 21(I) the focus-exposure process window 2130 for the mask of FIG. 21(C) overlaps the focus-exposure process window 2132 for the mask of FIG. 21(D) at a common focus-exposure process window 2134. This simulation example shows that a half-toned unattenuated chromeless mask may emulate an attenuated phase-shift mask of lower transmittance. FIG. 21(J) shows the exposure

latitude for varying amounts of depth of focus for the common focus-exposure area 2134.

FIGS. 22(A) through 22(D) show how the focus-exposure process window is enhanced using scattering bars to suppress the 0th diffraction order. FIG. 22(A) depicts the diffraction order graph for an uncorrected attenuated phase-shift 100 nm line with a 600 nm pitch. FIG. 22(B) depicts the diffraction orders for a corrected half-toned unattenuated chromeless layout. FIG. 22(C) is a graph showing the process window for the uncorrected attenuated phase-shift 100 nm line with a 600 nm pitch of FIG. 22(A). FIG. 22(D) is a graph showing the process window for the connected half-toned unattenuated chromeless layout of FIG. 22(B). Note that the corrected mask has four times the depth of focus (DoF) of the uncorrected mask.

FIGS. 23(A) through 23(F) show how an angle in a given pattern can be accurately compensated for using half-tone (HT) structures on the primary feature. FIG. 23(A) shows a global layout (uncorrected) of a pattern 2302 comprising primary features 2304. FIG. 23(B) shows a half-tone corrected portion 2306 of an angled primary feature. FIGS. 23(C) and 23(D) are aerial images for the respective features shown in FIGS. 23(A) and 23(B), respectively. FIGS. 23(E) and 23(F) are magnified views of the aerial images of the angled primary feature and half-tone-corrected angled primary feature of FIGS. 23(C) and 23(D), respectively. As seen in FIG. 23(E), the aerial image of the primary feature includes hot spots 2310, wherein the diffraction orders are decreased as a result of destructive interference in the diffraction pattern. However, as seen in FIG. 23(F), the aerial image of the primary feature does not include hot spots, thereby resulting in a more precise aerial image of the primary feature.

In addition, FIG. 23 shows that these half-tone structures are used to render a plurality of sizes, shapes and pitches such that the formed images produce their respective desired size and shape with sufficient image process tolerance. These images are typically made under identical exposure conditions, but not limited to single-exposure conditions. These half-toning structures can be used exterior, as assist features, or interior to the primary feature. These structures can range in transmission from 0% to 100% and they can be phase-shifted relative to the primary features or not.

Variations of the unattenuated phase-shift mask of the present invention are also possible. For example, while the hybrid disclosed in the exemplary embodiment set forth above may emulate a 26% attenuated phase-shift mask, alternatives are possible.

In the exemplary embodiment above, 600 nm pitch and 400 nm pitch have a common focus-exposure process window; however, such a relationship may be generalized. A general method for developing a focus-exposure process window that is common to multiple predetermined pitch sizes may be accomplished as described with the logic flow diagram of FIG. 24.

FIG. 24 is a logic flow diagram describing a method for designing unattenuated phase-shift masks patterns, whose corresponding diffraction patterns emulate the diffraction patterns corresponding to attenuated phase-shift masks, and whose focus-exposure process window is common to predetermined pitch sizes.

After an internal counter n is set to 1 (Step S1), the sizing dose, which is the dose of exposure energy needed to make a resist image of the target size, and line-width control for different features, including types, sizes, and pitches of interest, for different weak phase-shift mask transmissions

are determined (Step S2). This determination may be made, for example, using a lithography simulator (such as ProLith™ or Solid-C™). Next, the feature with the most sensitivity to exposure, focus and aberrations is determined (Step S3). This determination additionally may be made, for example, using a lithography simulator. Next, it is determined whether the internal counter n is greater than 1, thereby indicating whether Step S2 and Step S3 have been repeated (Step S4). If n is not greater than 1 (Step S4), then a modification to the imaging process is provided that lowers the pattern's sensitivity to exposure, focus, and aberrations (Step S5). The modification may include the use of different transmission weak phase-shifting masks, exposure apparatus conditions, and resist processes. Again, these modifications may be provided, for example, using a lithography simulator. The internal counter is then increased by 1 (Step S6). At this point Step S2 and Step S3 are repeated to ensure that the new process conditions provided during Step S5 did not change that which was observed after the first application of Step S2 and Step S3 (Step S7).

After the second run through Step S3, the internal counter n is determined to be greater than 1, indicating that Step S2 and Step S3 have been repeated (Step S4). As such, the results of the determinations made during the first run through Step S2 and Step S3 and the second run through Step S2 and Step S3 are respectively compared (Step S8). If the comparison between the determinations found during the two previous runs through Step S2 and Step S3 is not within a predetermined threshold, i.e. new process conditions introduced at Step S5 have changed that which was observed in the first run-through of the two previous steps Step S2 and Step S3, then a new modification to the imaging process is provided (return to Step S5). However, if the comparison between the determinations found during the two previous runs through Step S2 and Step S3 is within a predetermined threshold, i.e. new process conditions introduced at Step S5 have not changed that which was observed in the first run-through of the two previous steps Step S2 and Step S3, then the process proceeds to Step S9.

The mask layout conditions for the other features of interest, that first match the amplitude of the electric field at zero frequency of the diffraction pattern in the pupil plane of the exposure lens, and that place the maximum amplitude of the side-lobes for each isolated feature at the frequency of the reference geometry, are then determined (Step S9). Non-limiting methods for accomplishing the mask layout conditions for the other features of interest include halftoning each feature, biasing each feature, or adding scattering bars to isolated features. If scattering bars are used, the scattering bars should be placed at one reference pitch away from the feature being tuned, in order for the resulting diffracted image of the scattering bars plus their respective primary feature to match the diffracted image reference feature being tuned. Further, scattering bars may be halftoned, of opposite phase and/or biased, as prescribed by the mask fabrication technology used to fabricate such patterns.

Next, the enveloping sinc [$\text{sinc}(x)=\sin(x)/x$] function is tuned for all features so that they all have the same shape (Step S10). A sinc function relates to the non-discrete diffraction pattern for an isolated feature or for a series of lines and spaces. Adding scattering bars to an isolated feature modifies its sinc function by attenuating the image at certain frequencies and amplifying the image at other frequencies. The resultant diffraction pattern can resemble discrete orders even though it is the result of a sinc function. All diffraction orders of a series of lines and spaces are

separated by λ/pitch , and, without the sinc envelope, are of the same magnitude. The sinc function for a single space within the series of lines and spaces varies the amplitude of each order. If scattering bars are used, the spacing may need adjusting to move the side-lobe so that the maximum amplitude is placed outside of the numerical aperture of the lithographic apparatus and only the side of the side-lobe is inside the lens. This may be accomplished by reducing the primary feature's scattering bar structure pitch.

It is then determined whether all the features have the same aerial image shape attributes such as, for example, I-MAX (maximum intensity level), I-MIE (minimum intensity level), and Normalized Image Log Slope (NILS), and whether the process windows of each of the features overlap (Step S11). If all the features do not have the same aerial image shape attributes, or the process windows of each of the features do not overlap, then Step S9 is repeated with a new modification to the enveloping sinc function. If all the features have the same aerial image shape attributes, and the process windows of each of the features overlap, then the process stops, wherein an optimal phase shift mask is provided.

FIG. 25 schematically depicts a lithographic apparatus in which the mask according to the invention can be employed.

The apparatus comprises:

- a radiation system Ex, IL, for supplying a projection beam PB of radiation (e.g. UV radiation). In this particular case, the radiation system also comprises a radiation source LA;
- a first object table (mask table) MT provided with a mask holder for holding a mask MA (e.g. a reticle), and connected to first positioning means for accurately positioning the mask with respect to item PL;
- a second object table (substrate table) WT provided with a substrate holder for holding a substrate W (e.g. a resist-coated silicon wafer), and connected to second positioning means for accurately positioning the substrate with respect to item PL;
- a projection system ("lens") PL (e.g. a refractive, reflective or catadioptric system) for imaging an irradiated portion of the mask MA onto a target portion C (e.g. comprising one or more dies) of the substrate W.

As here depicted, the apparatus is of a transmissive type (i.e. has a transmissive mask). However, in general, it may also be of a reflective type, for example (with a reflective mask). Alternatively, the apparatus may employ another kind of patterning means, such as a programmable mirror array.

The source LA (e.g. a lamp or excimer laser) produces a beam of radiation. This beam is fed into an illumination system (illuminator) IL, either directly or after having traversed conditioning means, such as a beam expander Ex, for example. The illuminator IL may comprise adjusting means AM for setting the outer and/or inner radial extent (commonly referred to as σ -outer and σ -inner, respectively) of the intensity distribution in the beam. In addition, it will generally comprise various other components, such as an integrator IN and a condenser CO. Furthermore, the illuminator may comprise means for generating off-axis illumination configurations, such as annular, quadrupole, dipole and/or soft multipole configurations; these may be generated in a variety of ways, as detailed for example in European Patent Application EP 0 949 541 (incorporated herein by reference). In this way, the beam PB imprinting on the mask MA has a desired uniformity and intensity distribution in its cross-section.

It should be noted with regard to FIG. 25 that the source LA may be within the housing of the lithographic projection

apparatus (as is often the case when the source LA is a mercury lamp, for example), but that it may also be remote from the lithographic projection apparatus, the radiation beam which it produces being led into the apparatus (e.g. with the aid of suitable direction mirrors); this latter scenario is often the case when the source LA is an excimer laser.

The beam PB subsequently intercepts the mask MA, which is held on a mask table MT. Having traversed the mask MA, the beam PB passes through the lens PL, which focuses the beam PB onto a target portion C of the substrate W. With the aid of the second positioning means (and interferometric measuring means IF), the substrate table WT can be moved accurately, e.g. so as to position different target portions C in the path of the beam PB. Similarly, the first positioning means can be used to accurately position the mask MA with respect to the path of the beam PB, e.g. after mechanical retrieval of the mask MA from a mask library, or during a scan. In general, movement of the object tables MT, WT will be realized with the aid of a long-stroke module (course positioning) and a short-stroke module (fine positioning), which are not explicitly depicted in FIG. 25. However, in the case of a wafer stepper (as opposed to a step-and-scan apparatus) the mask table MT may just be connected to a short stroke actuator, or may be fixed.

The depicted apparatus can be used in two different modes:

In step mode, the mask table MT is kept essentially stationary, and an entire mask image is projected in one go (i.e. a single "flash") onto a target portion C. The substrate table WT is then shifted in the x and/or y directions so that a different target portion C can be irradiated by the beam PB;

In scan mode, essentially the same scenario applies, except that a given target portion C is not exposed in a single "flash". Instead, the mask table MT is movable in a given direction (the so-called "scan direction", e.g. the y direction) with a speed v , so that the projection beam PB is caused to scan over a mask image; concurrently, the substrate table WT is simultaneously moved in the same or positive direction at a speed $V=Mv$, in which M is the magnification of the lens PL (typically, $M=1/4$ or $1/5$). In this manner, a relatively large target portion C can be exposed, without having to compromise on resolution.

Although certain specific embodiments of the present invention have been disclosed, it is noted that the present invention may be embodied in other forms without departing from the spirit or essential characteristics thereof. The present embodiments are therefore to be considered in all respects as illustrative and not restrictive, the scope of the invention being indicated by the appended claims, and all changes that come within the meaning and range of equivalency of the claims are therefore intended to be embraced therein.

What is claimed is:

1. A device manufacturing method comprising the steps of:

- (a) providing a substrate that is at least partially covered by a layer of radiation-sensitive material;
- (b) providing a projection beam of radiation using a radiation system;
- (c) using a pattern on a mask to endow the projection beam with a pattern in its cross-section;
- (d) projecting the patterned beam of radiation onto a target portion of the layer of radiation-sensitive material, wherein, the step (c):

use is made of a phase-shifting mask comprising at least one unattenuated, halftoned, phase-shift feature;

the mask is off-axis illuminated by the radiation system.

2. A device manufactured using a method according to claim 1.

3. A device manufacturing method comprising the steps of:

- (a) providing a substrate that is at least partially covered by a layer of radiation-sensitive material;
- (b) providing a projection beam of radiation using a radiation system;
- (c) using a pattern on a mask to endow the projection beam with a pattern in its cross-section;
- (d) projecting the patterned beam of radiation onto a target portion of the layer of radiation-sensitive material, wherein, in step (c):

use is made of a phase-shifting mask comprising at least one feature, wherein said at least one feature includes halftoned, phase-shifted, transparent features; and

the mask is off-axis illuminated by the radiation system.

4. A device manufactured using a method according to claim 3.

5. A computer program product for controlling a computer comprising a recording medium readable by the computer, means recorded on the recording medium for directing the computer to generate at least one file corresponding to a phase shifting mask capable of transferring an image including 0^{th} diffraction order and $\pm 1^{st}$ diffraction orders, onto a material, said generation of said file comprising the step of:

generating a phase-shifting mask comprising at least one unattenuated, halftoned, phase-shift feature;

said phase-shifting mask being utilized in conjunction with off-axis illumination such that radiation traverses said mask and impinges on said material.

6. A computer program product for controlling a computer comprising a recording medium readable by the computer, means recorded on the recording medium for directing the computer to generate at least one file corresponding to a phase shifting mask capable of transferring an image, including 0^{th} diffraction order and $\pm 1^{st}$ diffraction orders, onto a material, said generation of said file comprising the step of:

generating a phase-shifting mask comprising at least one feature, wherein said at least one feature includes halftoned, phase-shifted, transparent features; and

said phase-shifting mask being utilized with off-axis illumination such that radiation passes through said mask onto said material.

7. The computer program product of claim 6, wherein said at least one feature further includes semi-transparent features.

8. The computer program product of claim 6, wherein said at least one feature further includes opaque features.

9. A computer program product for controlling a computer comprising a recording medium readable by the computer, means recorded on the recording medium for directing the computer to generate at least one file corresponding to a mask capable of transferring an image onto a material, said generation of said file comprising the step of:

generating a phase-shifting mask comprising at least two unattenuated, halftoned, phase-shift features having a width w , said features separated by a width substantially equal to w ,

wherein said mask provides an image including 0^{th} diffraction order and $\pm 1^{st}$ diffraction orders, when illuminated.

10. The computer program of claim 9, wherein a focus-exposure process window for maintaining a predetermined resist line-width sizing of said mask is substantially common to an attenuated, phase-shift mask of a similar pitch.

11. A computer program product for controlling a computer comprising a recording medium readable by the computer, means recorded on the recording medium for directing the computer to generate at least one file corresponding to a mask capable of transferring an image onto a material, said generation of said file comprising the step of:

generating a phase-shifting mask comprising at least two halftoned, phase-shifted, transparent features having a width w , said features separated by a width substantially equal to w ,

wherein said mask provides an image including 0^{th} diffraction order and $\pm 1^{\text{st}}$ diffraction orders, when illuminated.

12. The computer program of claim 11, wherein said at least two features further include semi-transparent features.

13. The computer program of claim 11, wherein said at least two features further include opaque features.

14. The computer program of claim 11, wherein a focus-exposure process window for maintaining a predetermined resist line-width sizing of said mask is substantially common to an attenuated, phase-shift mask of a similar pitch.

15. A method of designing a phase-shifting mask for transferring an image onto a material, said image including first features having a first pitch and second features having a second pitch different than said first pitch, said method comprising the step of:

modifying in said mask at least one of said first and second features to include at least one unattenuated, halftoned phase-shift feature that emulates an arbitrary percentage transmission between 6% and 100%, whereby said first and second features in said mask emulate different percentage transmissions such that said first and second features share a common exposure latitude and a corresponding depth of focus.

16. A method according to claim 15 wherein at least one of said first and second features comprise an equal line/space chromeless pattern and said step of modifying is carried out on said equal line/space chromeless pattern such that said pattern produces a 0^{th} order having a non-zero amplitude when illuminated.

17. A method according to claim 15, wherein said step of modifying is carried out such that the modified features produce a diffraction pattern and aerial image corresponding to a partially transparent, attenuated phase-shaft mask, having an arbitrary percentage transmission.

18. A method according to claim 15, wherein said unattenuated, halftoned, phase-shift feature is a primary feature.

19. A method according to claim 15, wherein said unattenuated, halftoned, phase-shift feature is an assist feature.

20. A method of fabricating a phase-shifting mask for transferring an image onto a material, the method comprising designing said mask according to the method of claim 1, and fabricating a mask according to the design.

21. A device manufacturing method comprising the steps of:

providing a substrate that is at least partially covered by a layer of radiation-sensitive material;

providing a projection beam of radiation using a radiation system;

using a pattern on a mask to endow the projection beam with a pattern in its cross-section; and

projecting the patterned beam of radiation onto a target portion of the layer of radiation-sensitive material; characterized in that:

said mask includes first features having a first pitch and second features having a second pitch, at least one of said first features having been modified to include at least one unattenuated, halftoned phase-shift feature that emulates an arbitrary percentage transmission between 6% and 100%, whereby said first and second features in said mask emulate different percentage transmissions such that said first and second features share a common exposure latitude and a corresponding depth of focus.

22. A device manufacturing method according to claim 21, wherein said mask is off-axis illuminated by said radiation system.

23. A device manufacturing method according to claim 21, wherein at least one of said first and second features comprise an equal line/space chromeless pattern and said step of modifying is carried out on said equal line/space chromeless pattern such that said pattern produces a 0^{th} order having a non-zero amplitude when illuminated.

24. A device manufacturing method according to claim 21, wherein said step of modifying is carried out such that the modified features produce a diffraction pattern and aerial image corresponding to a partially transparent, attenuated phase-shaft mask, having an arbitrary percentage transmission.

25. A device manufacturing method according to claim 21, wherein said unattenuated, halftoned, phase-shift feature is a primary feature.

26. A device manufacturing method according to claim 21, wherein said unattenuated, halftoned, phase-shift feature is an assist feature.

27. A computer program product for controlling a computer comprising a recording medium readable by the computer, means recorded on the recording medium for directing the computer to generate at least one file corresponding to a phase-shift mask for transferring an image onto a material, said image including first features having a first pitch and second features having a second pitch different than said first pitch, said generation of said file comprising the step of:

modifying in said mask at least one of said first and second features to include at least one unattenuated, halftoned phase-shift feature that emulates an arbitrary percentage transmission between 6% and 100%,

whereby said first and second features in said mask emulate different percentage transmissions such that said first and second features share a common exposure latitude and a corresponding depth of focus.

28. The computer program product of claim 27, wherein at least one of said first and second features comprise an equal line/space chromeless pattern and said step of modifying is carried out on said equal line/space chromeless pattern such that said pattern produces a 0^{th} order having a non-zero amplitude when illuminated.

29. The computer program product of claim 27, wherein said step of modifying is carried out such that the modified features produce a diffraction pattern and aerial image corresponding to a partially transparent, attenuated phase-shaft mask, having an arbitrary percentage transmission.

30. The computer program product of claim 27, wherein said unattenuated, halftoned, phase-shift feature is a primary feature.

31. The computer program product of claim 27, wherein said unattenuated, halftoned, phase-shift feature is an assist feature.