



US00RE40071E

(19) **United States**
(12) **Reissued Patent**
Svetal et al.

(10) **Patent Number:** **US RE40,071 E**
(45) **Date of Reissued Patent:** ***Feb. 19, 2008**

(54) **MULTIPLE PLANE WEIGH PLATTER FOR MULTIPLE PLANE SCANNING SYSTEMS**

2,738,184 A 3/1956 Hart
4,064,954 A 12/1977 Rock
4,425,975 A 1/1984 Luchinger
4,656,344 A 4/1987 Mergenthaler et al.

(75) Inventors: **Michael P. Svetal**, Eugene, OR (US);
Mohan LeeLaRama Bobba, Eugene, OR (US);
Matt D. Schler, Eugene, OR (US);
Gary J. Oldham, Eugene, OR (US)

(Continued)

(73) Assignee: **Datalogic Scanning, Inc.**, Eugene, OR (US)

OTHER PUBLICATIONS

(*) Notice: This patent is subject to a terminal disclaimer.

ICL Datchecker brochure on the Orion Scanner/Scale (about 1989).

Orion Scanner and Scale Installation and Maintenance Manual, pp. A2–A4 (1989).

ICL Datchecker brochure on the Orion Scanner/Scale entitled “A Total Scanning Solution” (undated).

(21) Appl. No.: **10/447,746**

Spectra–Physics® brochure on the Scanning Scale Model 760SLS (about 1989).

(22) Filed: **May 28, 2003**

NCI brochure on the NCI Model 4710 Scanner Scale (undated).

Related U.S. Patent Documents

Reissue of:

(Continued)

(64) Patent No.: **6,237,852**
Issued: **May 29, 2001**
Appl. No.: **09/150,552**
Filed: **Sep. 9, 1998**

Primary Examiner—Daniel Stcyr

(74) *Attorney, Agent, or Firm*—Stoel Rives LLP

U.S. Applications:

(63) Continuation of application No. 08/539,584, filed on Oct. 5, 1995, now Pat. No. 5,834,708.

(60) Provisional application No. 60/000,052, filed on Jun. 8, 1995.

(51) **Int. Cl.**
G06K 7/10 (2006.01)

(57) **ABSTRACT**

(52) **U.S. Cl.** **235/462.43**; 235/462.14;
177/180; 177/238

(58) **Field of Classification Search** 235/383,
235/385, 462.01, 462.14, 462.25, 462.4,
235/462.42, 462, 462.43, 483; 177/180, 181,
177/238, 262

See application file for complete search history.

A multi-plane scanner having a dual plane scanner with a horizontal window and a vertical window and a load cell/ weigh platter weighing apparatus such that the weigh platter itself is a dual plane object with vertical and horizontal sections. The size and orientation of the planes of the weigh platter correspond to the size and orientation of the scan windows of the dual plane scanner, and each plane of the weigh platter has a transparent area (typically central), or “platter window”, corresponding to a respective scan windows of the scanner for allowing transmission of scanned optical beams and optical barcode signals through each of the planes of the weigh platter. The platter is sufficiently rigid to permit accurate weighing whether the object being weighed is placed solely on the horizontal section of the platter or in part on the vertical section. The vertical and horizontal sections of the platter are sealed together to prevent passage of debris therebetween.

(56) **References Cited**

U.S. PATENT DOCUMENTS

2,617,641 A 11/1952 Marshall, Jr. et al.

93 Claims, 10 Drawing Sheets

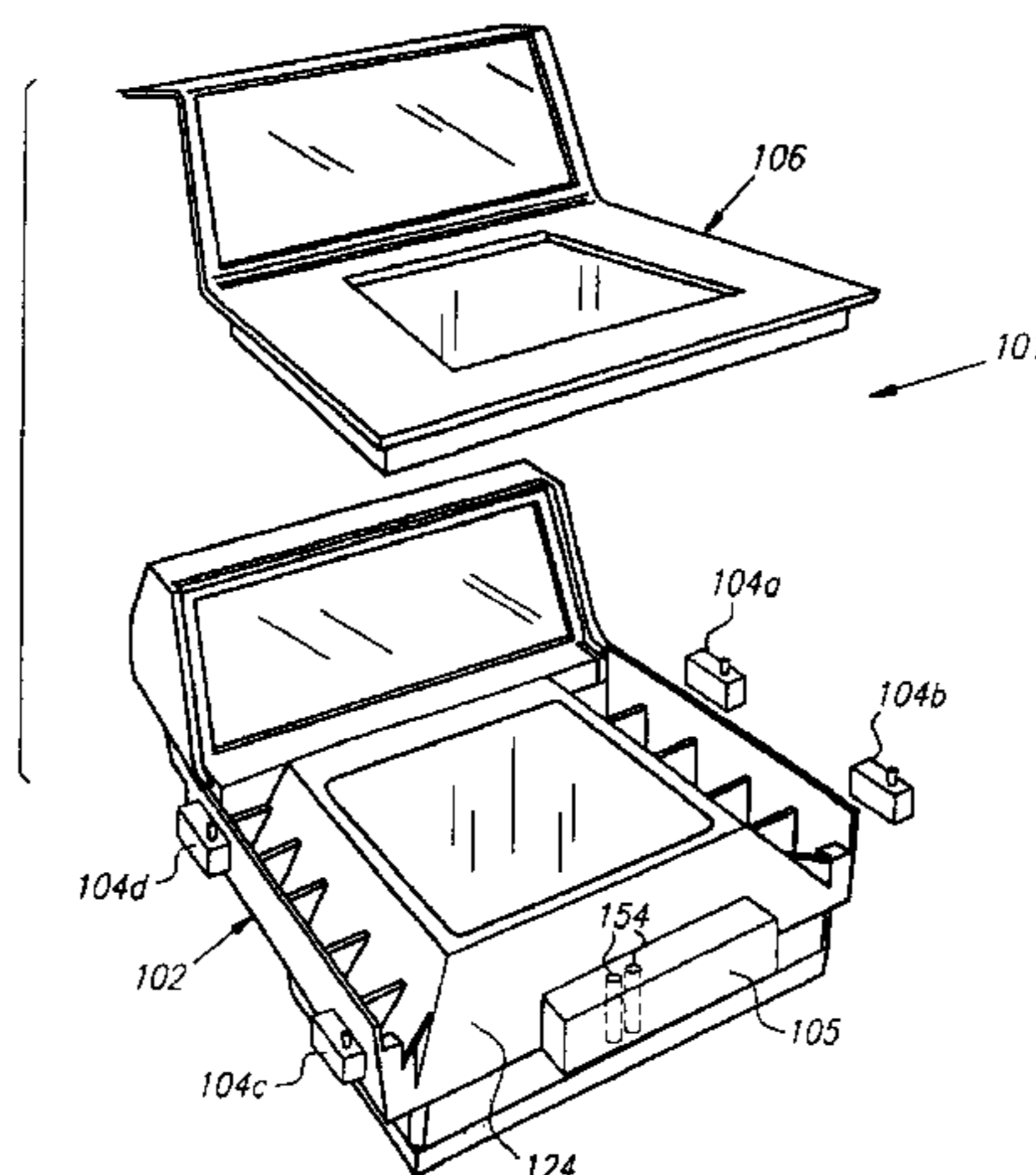

U.S. PATENT DOCUMENTS

4,669,663	A	6/1987	Meyer	
4,881,606	A	11/1989	Halfon et al.	
4,909,338	A	3/1990	Vitunic et al.	
4,971,176	A	11/1990	Nojiri et al.	
4,971,177	A	11/1990	Nojiri et al.	
4,991,692	A	2/1991	Nojiri et al.	
5,005,670	A	4/1991	Nojiri	
5,073,702	A	12/1991	Schuhmacher	
5,086,879	A	2/1992	Latimer et al.	
5,139,100	A	8/1992	Brauneis	
5,143,164	A	9/1992	Nahar	
5,206,491	A	4/1993	Katoh et al.	
5,229,588	A	7/1993	Detwiler et al.	
5,410,108	A	4/1995	Williams et al.	
5,475,207	A	12/1995	Bobba et al.	
5,531,293	A	* 7/1996	Nahar	186/59
5,588,621	A	12/1996	Collins, Jr. et al.	
5,773,767	A	6/1998	Collins, Jr. et al.	
5,886,336	A	3/1999	Tang et al.	
6,830,186	B1	12/2004	Nahar	

OTHER PUBLICATIONS

PSC Inc. brochure from PSC web page on the Magellan® 360 Scanner/Scale (<http://www.pscnet.com/magelspe.htm>) (1997); the Magellan® Scanner/Scale is the scanner/scale as described in the background of the present application.
 NCR Model 7870 Scanner/Scale User's Guide excerpts (pp. i, xiii through xvi, 3-16 through 3-18(1993)).
 Brochure from NCR web page on the NCR Model 7870 Bi-Optic Scanner and Scanner/Scale (<http://www.ncr.com/product/retail/products/catalog/7870.shtml>) (1997). See excerpts from the 1993 User's Guide above.

Brochure from NCR web page on the NCR Model 7875 Bi-Optic Aggressive Read Scanner/Scale (<http://www.ncr.com/product/retail/products/catalog/7875.shtml>) (1997).

ICL Model 9500 Scanner/Scale brochure, ICL Retail Systems, Dallas, TX (about 1997).

Wincor Nixdorf WE02 Scanner Scale (Jan. 3, 2000); <http://www.mch.sni.de/eng/products/retail/hardware/scanner/waage.html>.

Complaint for Patent Infringement and Declaratory Judgment, *NCR Corporation v. PSC, Inc. and PSC Scanning, Inc.*, Case No. 3:04cv0142 (S.D. Ohio, Dayton), filed Apr. 30, 2004.

Civil Docket, *NCR Corporation v. PSC, Inc. and PSC Scanning, Inc.*, Case No. 3:04cv0142 (S.D. Ohio (Dayton)), printed Jul. 8, 2004.

Complaint for Patent Infringement, *PSC Scanning, Inc. v. NCR Corporation*, Civil Action No. 04-6137-AA (D. Oregon, Eugene), filed May 5, 2004.

Civil Docket, *PSC Scanning, Inc. v. NCR Corporation*, Civil Action No. 04-6137-AA (D. Oregon (Eugene)), printed Jul. 8, 2004.

PSC Scanning, Inc., Claim chart for U.S. Patent No. 6,237, 852, prepared Oct. 18, 2005, unpublished. (Submitted under MPEP 724.)

* cited by examiner

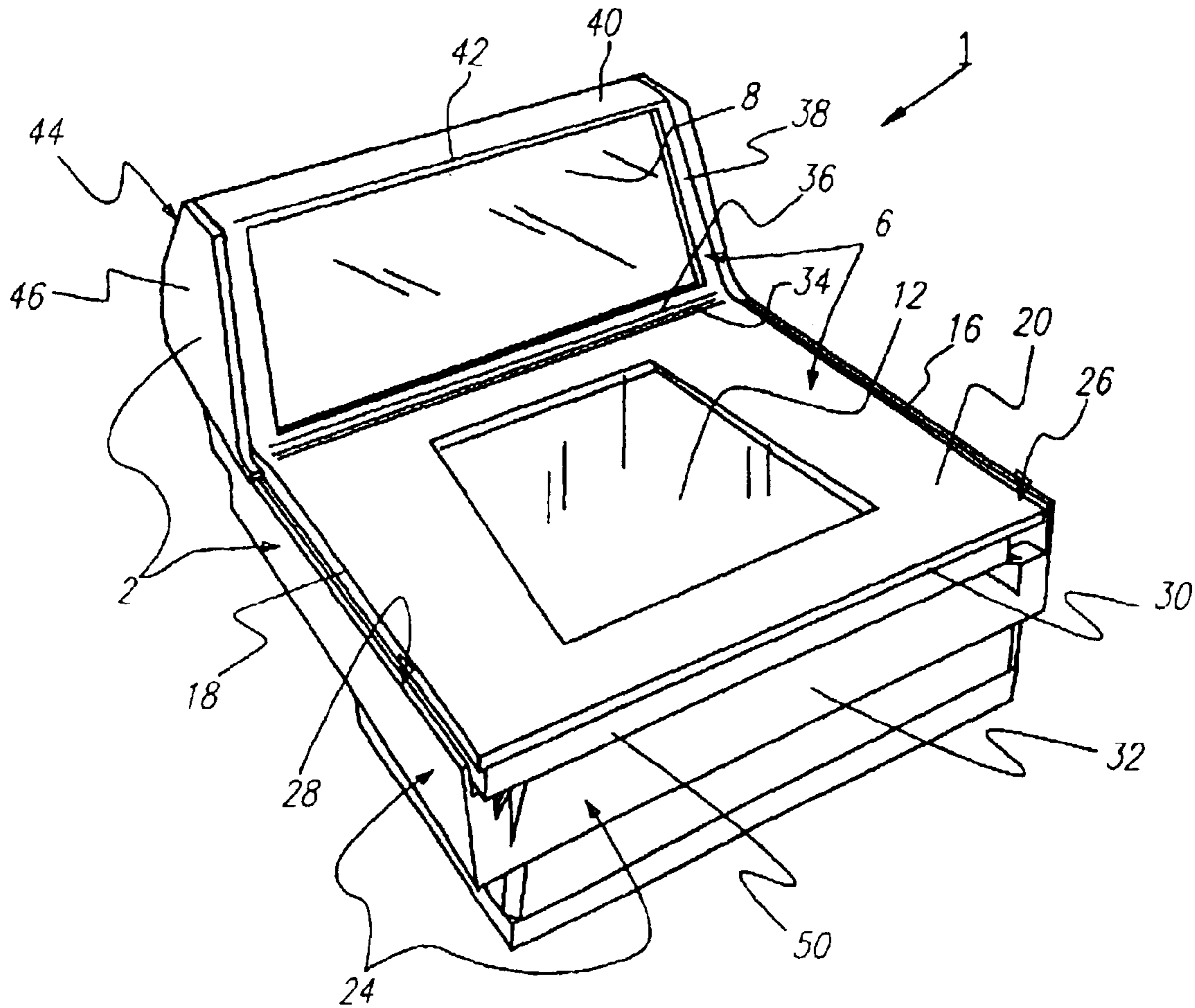

FIG. 1

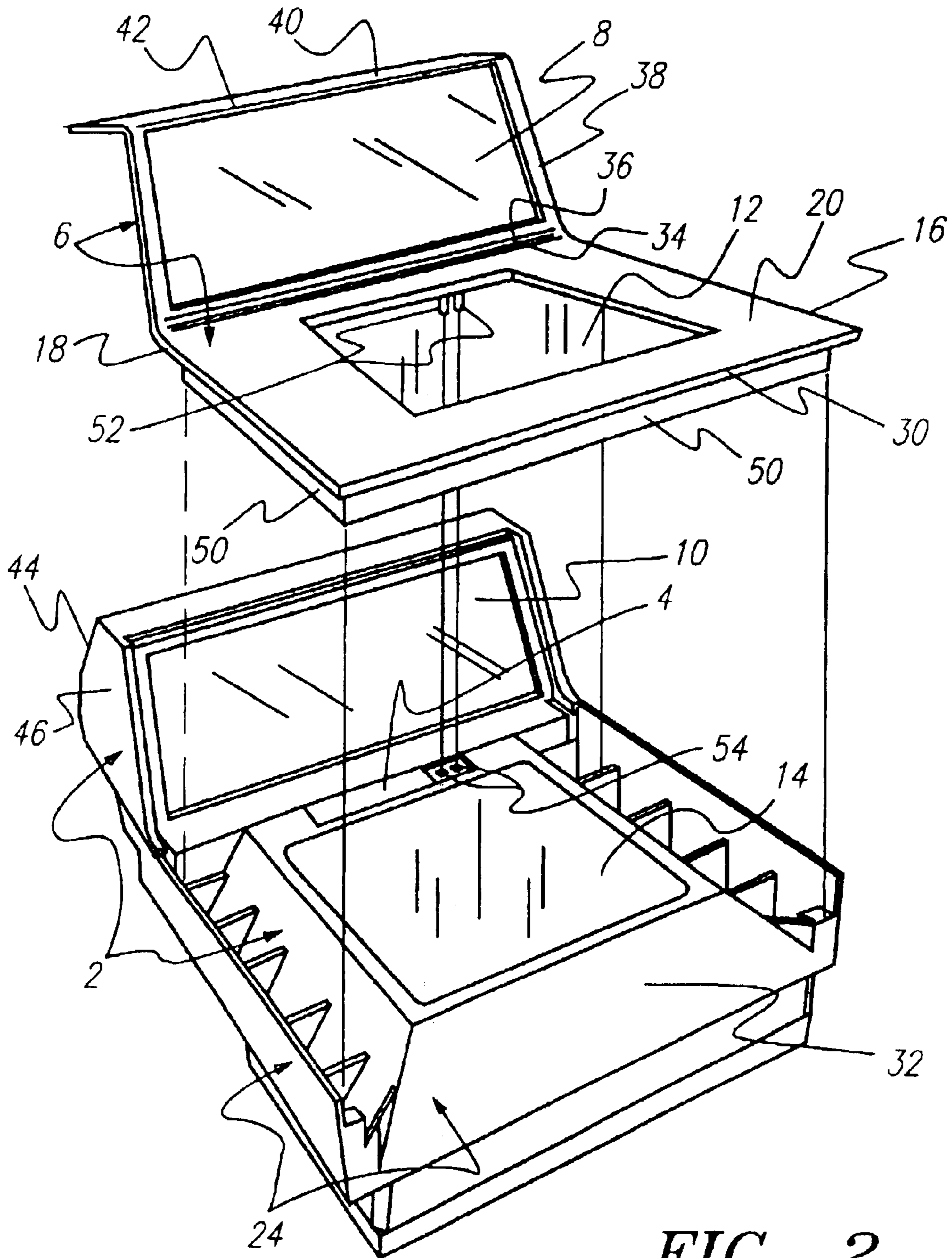

FIG. 2

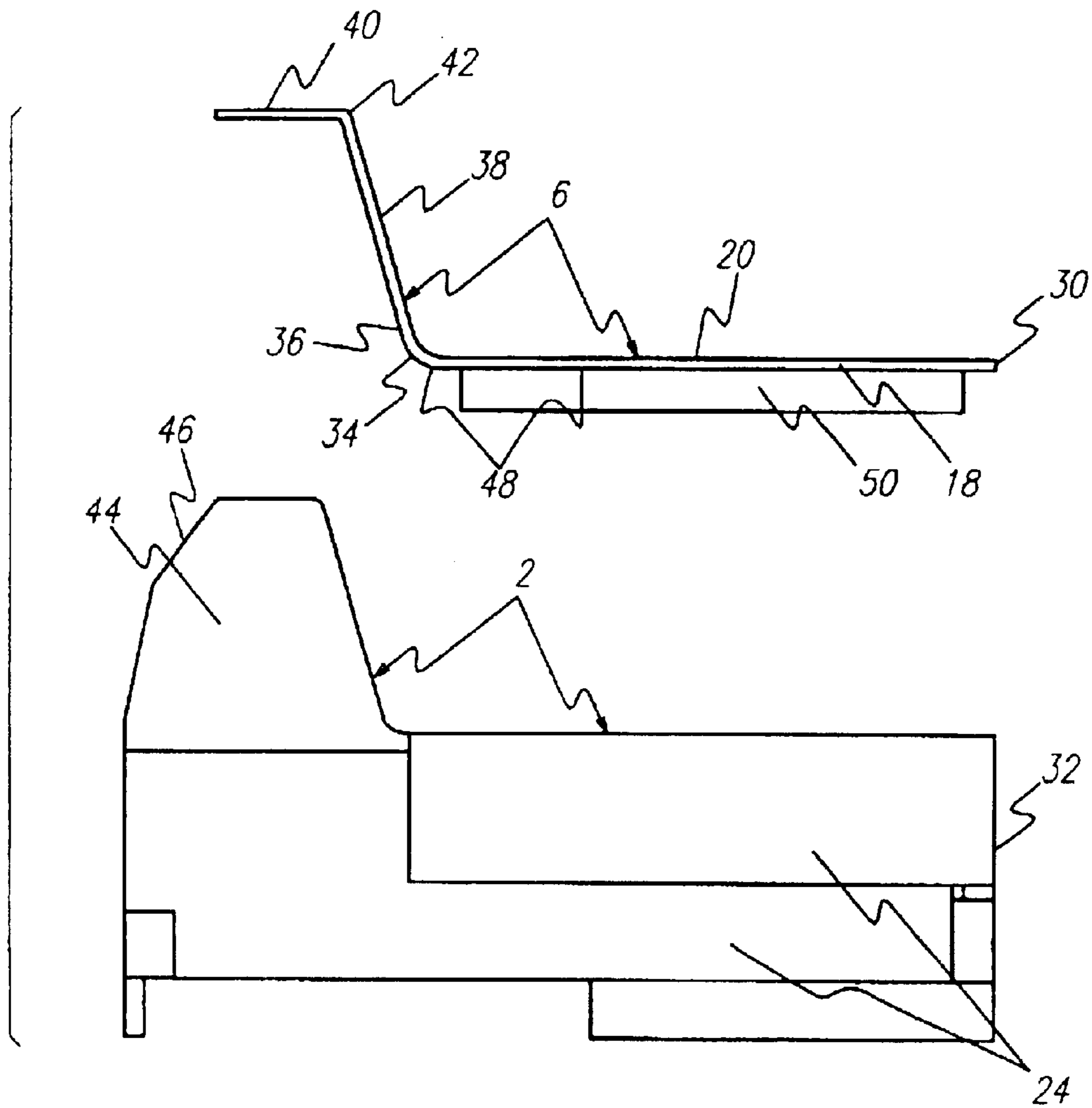

FIG. 3

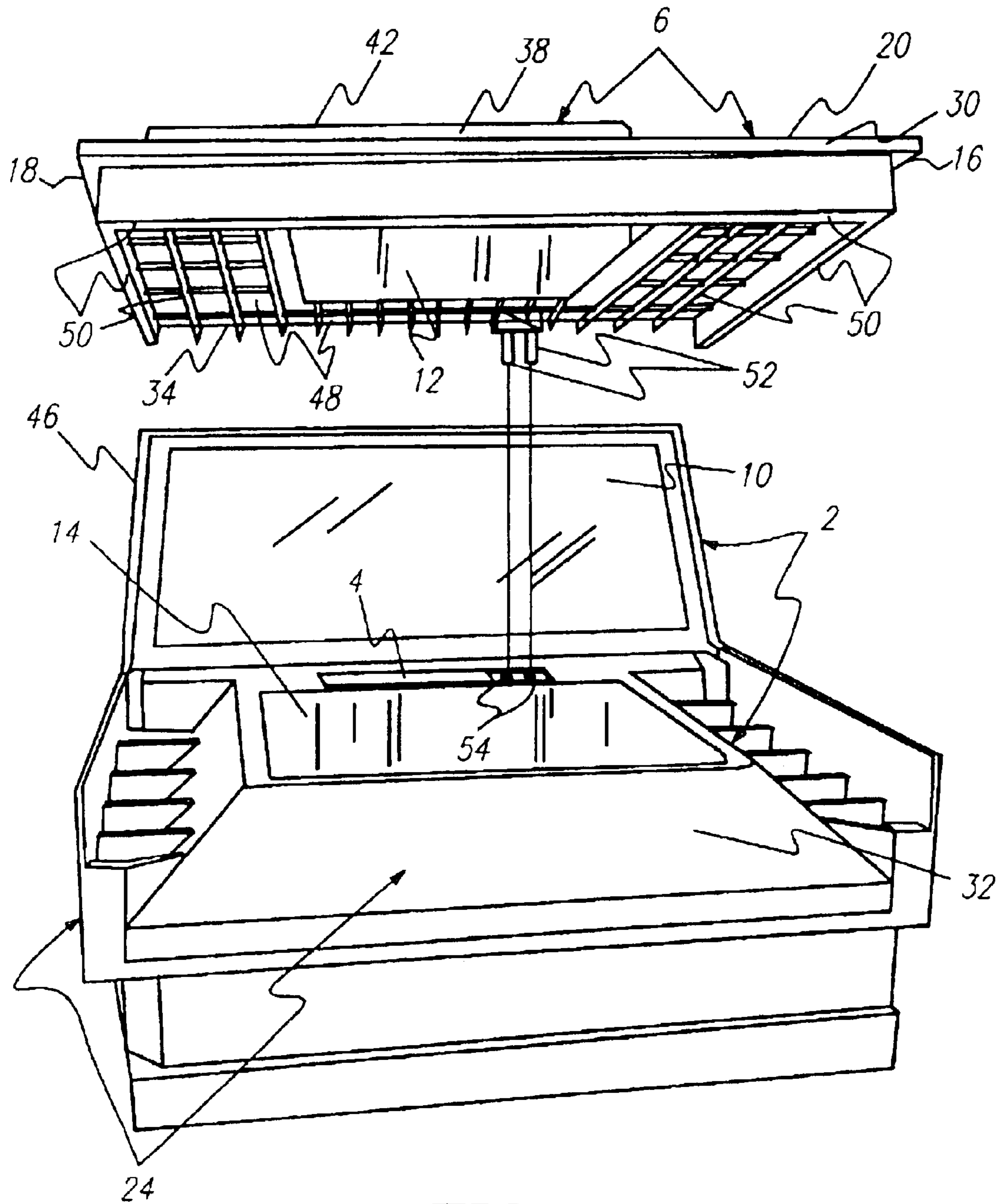

FIG. 4

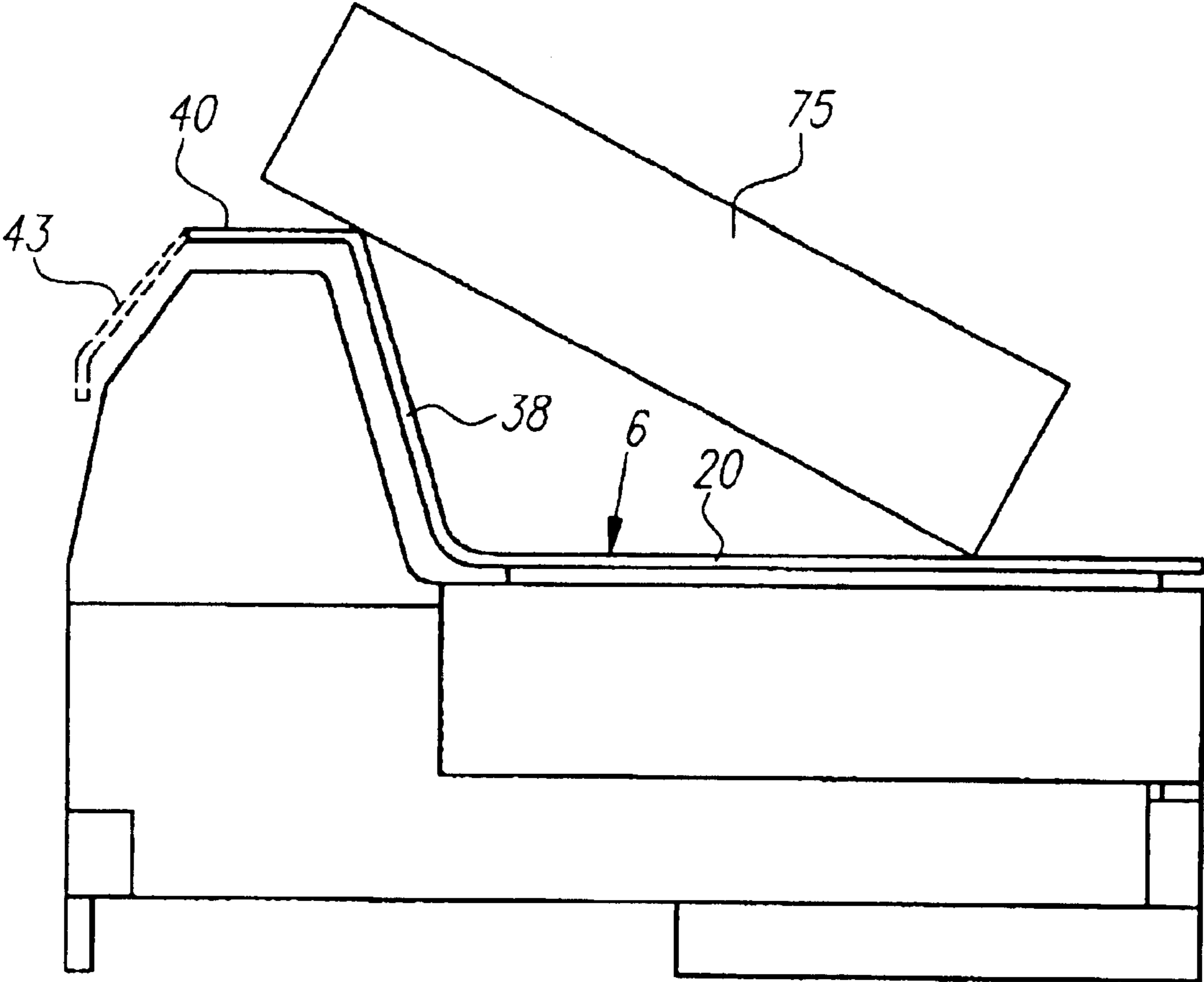

FIG. 5

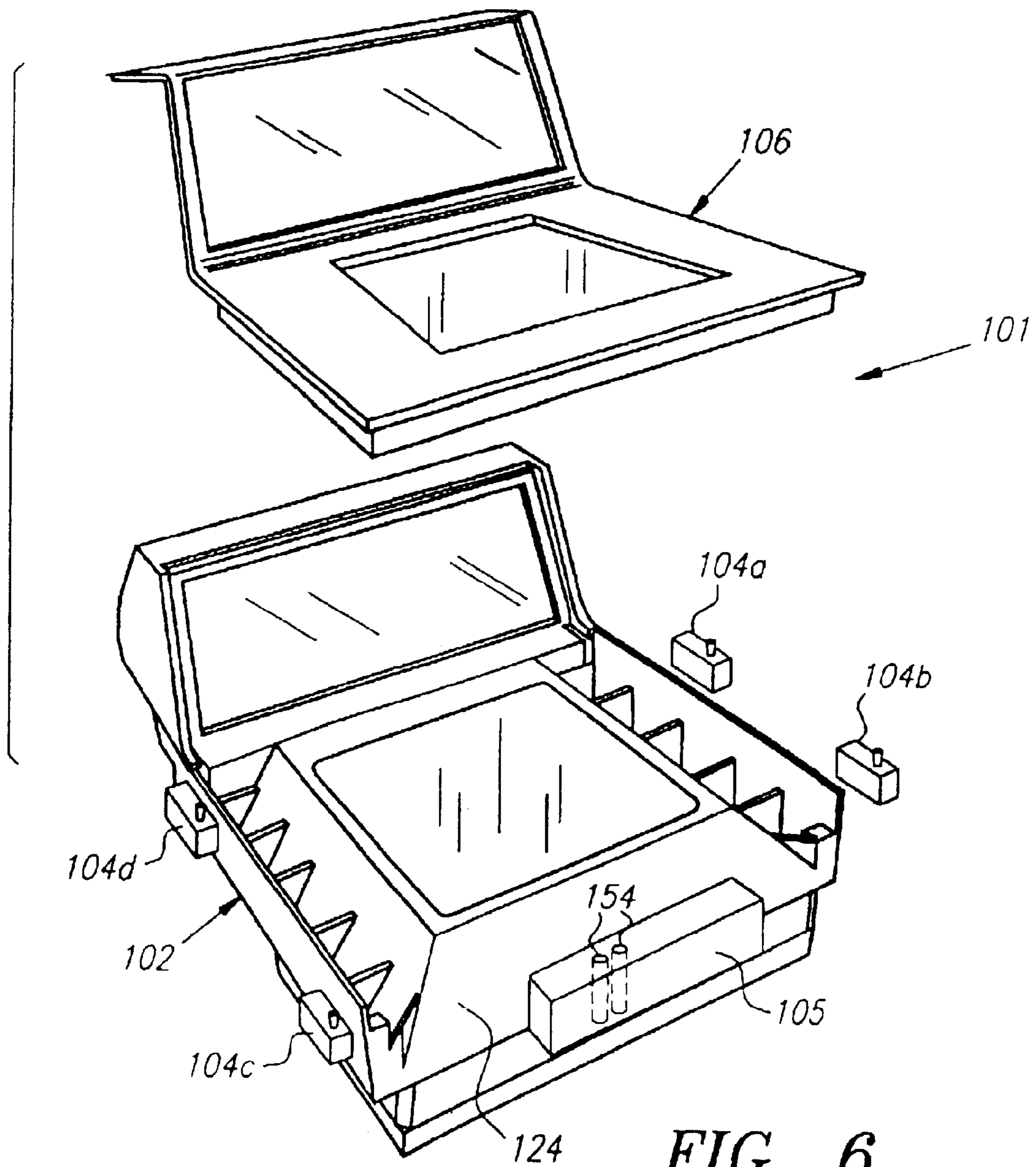

FIG. 6

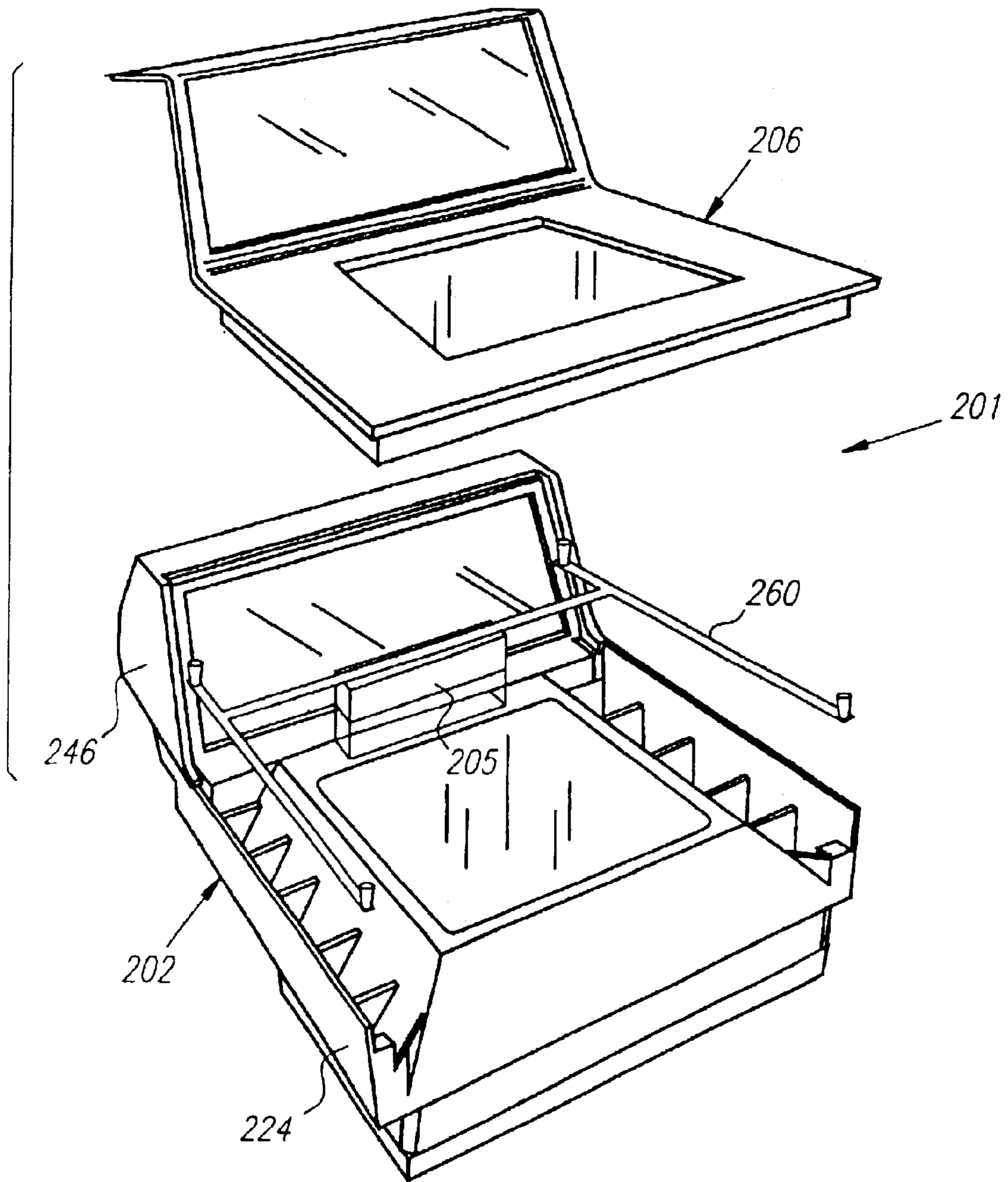

FIG. 7

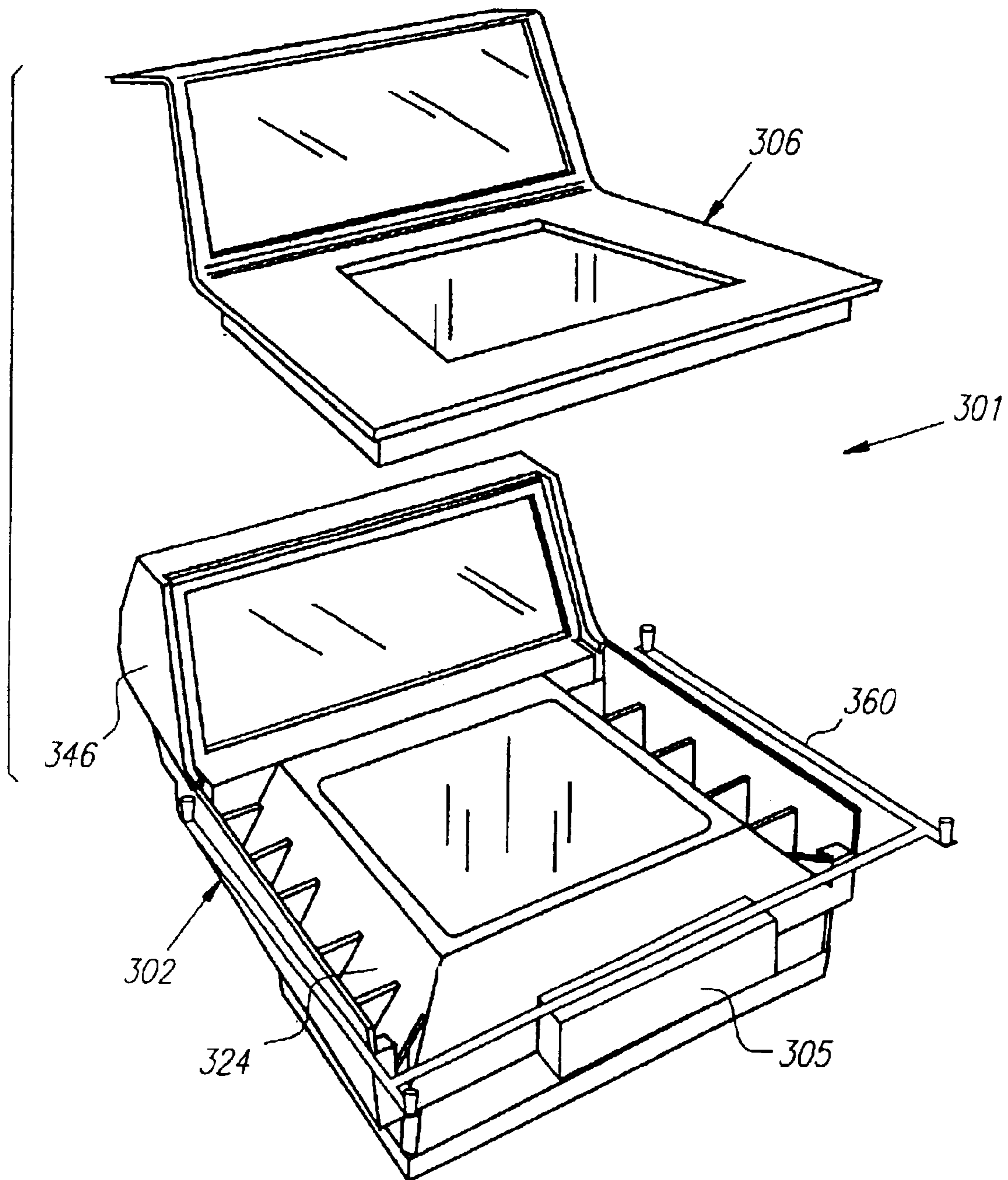

FIG. 8

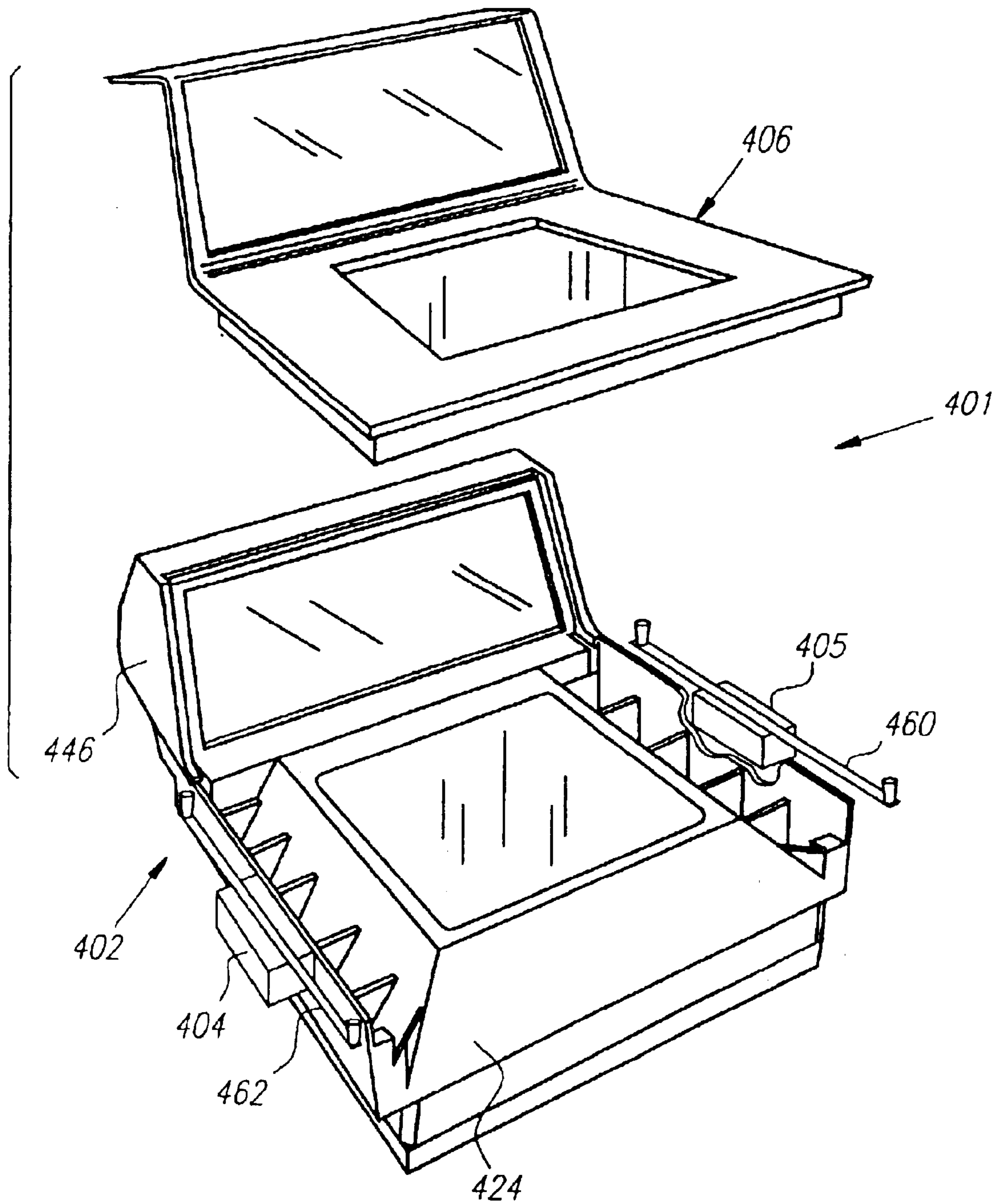

FIG. 9

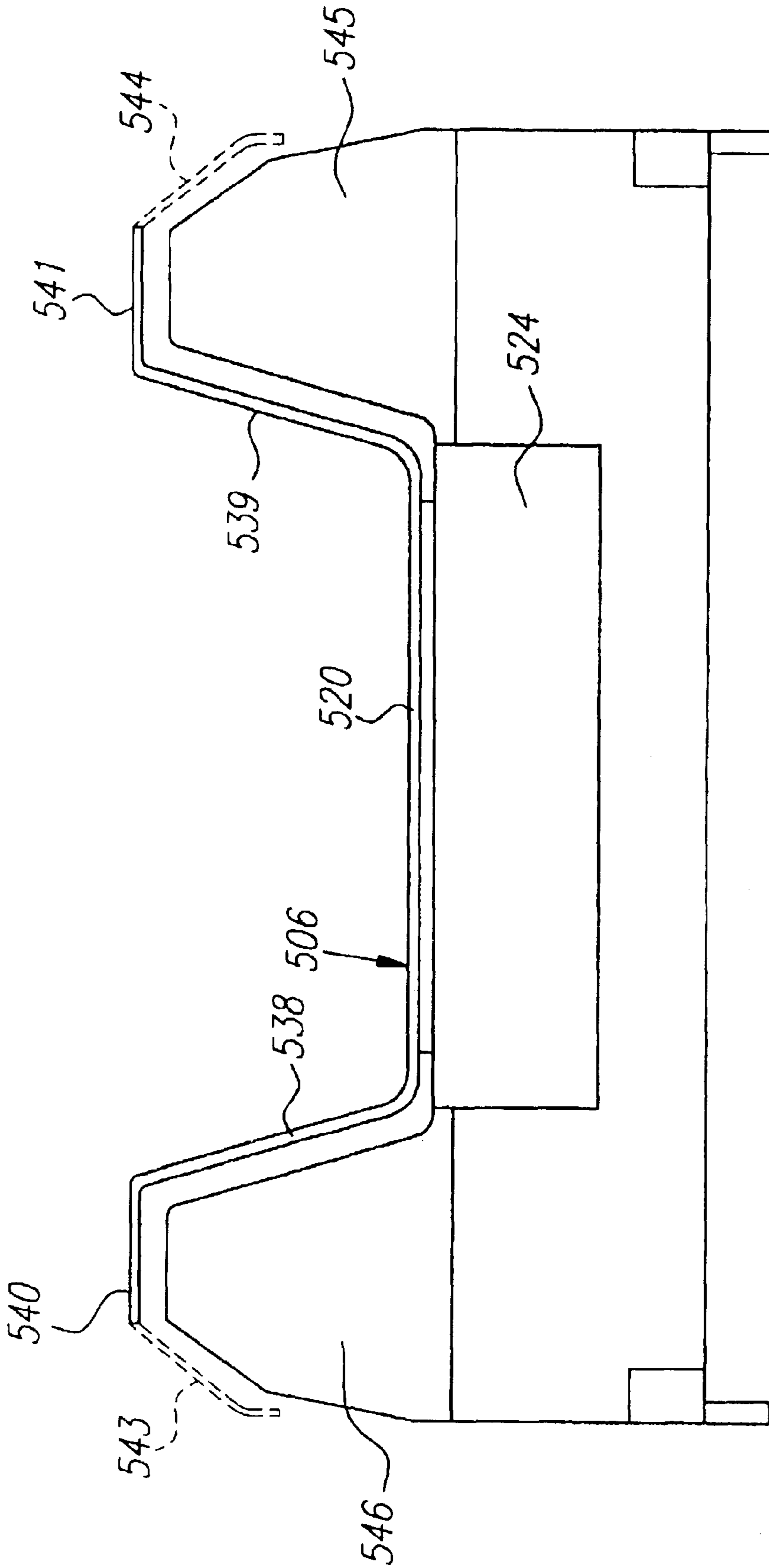

FIG. 10

MULTIPLE PLANE WEIGH PLATTER FOR MULTIPLE PLANE SCANNING SYSTEMS

Matter enclosed in heavy brackets [] appears in the original patent but forms no part of this reissue specification; matter printed in italics indicates the additions made by reissue.

RELATED APPLICATIONS

This application is a [division] continuation of Ser. No. 08/539,584 filed Oct. 5, 1995 [noe] now U.S. Pat. No. [5,834,208] 5,834,708 which [is a continuation-in-part] claims the benefit of provisional application Ser. No. 60/000,052 filed Jun. 8, 1995 which is hereby incorporated by reference.

BACKGROUND OF THE INVENTION

The field of the present invention relates to fixed optical reading systems, for example bar code scanning systems, which include multiple windows through which optical reading may be accomplished.

Fixed barcode scanners having multiple windows capable of reading objects in a variety of orientations have been on the market for some time. One such "multi-plane" scanner is described in U.S. Pat. No. 5,475,207 entitled "Multiple Plane Scanning System for Data Reading Applications", which is hereby incorporated by reference. These multi-plane or "multi-window" scanners are high performance scanners which use one or more scanned optical beams to generate multiple scan patterns. Mechanically, these scanners have one or more scan engines and multiple scan windows oriented in different planes from each other, instead of a single scan window as in single-plane scanners. One of the scan windows is usually oriented horizontally, defining a horizontal scan plane, while the other window or windows are oriented to have significant vertical components and define additional substantially vertical scan plane(s). The additional vertical scan plane(s) enable the scanner to successfully read a barcode from a larger fraction of the surface of the object for a given object orientation.

Horizontal window barcode scanning systems which also include a weigh scale apparatus have also been available for several years. One such "scanner scale" weighing apparatus is described in U.S. Pat. No. 5,410,108, which is hereby incorporated by reference. The weighing apparatus may take the form of a load cell which bears a rigid framework referred to hereinafter as a "spider". The spider supports a weigh platter onto which objects are placed to be weighed.

Alternatively, the apparatus may be a "spiderless" scale in which the weigh platter is sufficiently rigid in itself to obviate the need for a spider. The weigh platter may comprise a horizontal flat piece of rigid material such as metal or a combination of metal [amd] and plastic with an optically transparent portion corresponding to a horizontal scan window. The transparent portion allows transmission of optical beams out from a scan engine and transmission of optical barcode signals back into the scanner. The load cell, which is well-known in the art, usually comprises a machined piece of aluminum with one or more strain gauges attached thereto. When an object is placed on the weigh platter, the mechanical stress thus applied to the load cell generates electrical signals from the strain gauges, and these signals are in turn used to determine the weight of the object. When incorporated as part of an optical barcode scanning system, the load cell, spider, and weigh platter may preferably comprise a separate sub-assembly from the optical scanner.

In one device such as the 1994 version of the Spectra-Physics MAGELLAN™ scanner/scale, the load cell and spider are positioned below the scan engine, and vertical support members are connected to the spider, extend upward around the scanner, and are connected to the weigh platter, which is positioned over the scan engine.

Fixed optical barcode scanners with multiple scan planes have been combined with a weighing apparatus such as the Spectra-Physics MAGELLAN™ scanner/scale. The MAGELLAN™ scanner scale is a dual plane scanner having a vertical scan plane and a horizontal scan plane with a horizontal weigh platter.

Multiple plane scanners such as the MAGELLAN™ unit, however, may encounter several problems when a weigh scale is being incorporated. The addition of a second scan plane adds to the size of the scan unit. Since these systems are often used in locations where space is a significant limitation, such as a supermarket checkout stand, the addition of a second scan plane often comes at the expense of decreased area of the horizontal weigh platter. This decreases in area increases the likelihood that the vertical scan components, vertical scan window, and their associated housing will interfere mechanically with an object placed on the weigh platter to be weighed. Moreover, the limited size of the weigh platter may result in an object being weighed (depending upon its size) to extend past the edge of the platter onto the counter potentially resulting in an inaccurate weight measure.

In addition, horizontal single plane scanners with weigh platters typically have an air gap which completely surrounds the platter, allowing dust, dirt, and debris to fall around the scanner (but not on the horizontal scan window) so as not to interfere with scanner function. Moreover, the weigh platter may simple extend beyond the horizontal extent of the horizontal plane scanner.

In a dual plane scanner, since there can be no air gap or weigh platter extension on the side of the weigh platter adjacent the vertical scan window, debris may accumulate under the weigh platter which in turn may obstruct the horizontal scan window or may inhibit proper scale operation.

SUMMARY OF THE INVENTION

The present invention relates to optical reading systems, such as for example barcode scanning systems, which incorporate multiple plane scanning. In its preferred application, the invention relates to a multiple scan plane (two or more planes) scanning systems incorporating a multi-plane cover. A first preferred embodiment comprises a dual plane scanner and a load cell/weigh platter weighing apparatus, wherein the weigh platter itself is a dual plane object. The size and orientation of the planes of the weigh platter correspond to the size and orientation of the scan windows of the dual plane scanner, and each plane of the weigh platter has a transparent area, or "platter window", corresponding to a respective scan windows of the scanner, thereby allowing transmission of scanned optical beams and optical barcode signals through each of the planes of the weigh platter.

BRIEF DESCRIPTION OF THE DRAWINGS

FIG. 1 is a perspective view of a dual plane scanner with a dual plane spiderless weigh platter according to the present invention;

FIG. 2 is an exploded perspective view of the scanner and weigh platter of FIG. 1 showing an integral load cell;

3

FIG. 3 is an exploded right side elevation view of the scanner and weigh platter of FIG. 1;

FIG. 4 is an exploded front perspective view of the scanner and weigh platter of FIG. 1 showing an integral load cell;

FIG. 5 is a side view of apparatus of FIGS. 1-4 with an oversized item being weighed;

FIG. 6 is an exploded view of an alternate apparatus having a spiderless design with multiple load cells;

FIG. 7 is an exploded view of another alternate apparatus having a spider with a load cell;

FIG. 8 is an exploded view of another alternate apparatus also having a spider with a load cell;

FIG. 9 is an exploded view of another alternate apparatus having a spider with multiple load cells; and

FIG. 10 is a side view of a another alternate apparatus illustrating three planes.

DETAILED DESCRIPTION OF PREFERRED EMBODIMENTS

The preferred embodiments will now be described with reference to the drawings. FIGS. 1-5 illustrate a two-plane scanner/weighing apparatus 1 including a scanner 2 with an integral load cell 4 and a two-plane spiderless weigh platter 6. When assembled the vertical platter window 8 is positioned in front of the vertical scan window 10 and the horizontal platter window 12 is positioned over the horizontal scan window 14. This relative positioning of the platter windows 8, 12 to the scan windows 10, 14 allows optical beams generated by the scan engine(s) to pass out through the scan windows and platter windows, and allows the resulting optical signals from a scanned barcode to pass in through the platter windows and the scan windows for detection and decoding. The window 8 may be oriented perfectly vertical, or it may be angled somewhat from absolute vertical as best shown in FIG. 3.

The lateral side edges 16, 18 of the horizontal section 20 of the weigh platter 6 and the horizontal scan housing portion 24 form air gaps 26, 28 on the lateral side edges (the right and left sides as viewed in FIG. 1) of the weigh platter 6, while the front edge 30 of the horizontal plane of the weigh platter 6 extends beyond the front 32 edge (i.e., the edge nearest the checker) of the horizontal scanner housing portion 24. The back edge 34 of the horizontal section of the weigh platter is rigidly connected to the bottom edge 36 of the vertical section 38 of the weigh platter, thereby forming an integral structure with a continuous surface, thereby preventing debris from passing below the weigh platter 6 which could obstruct the horizontal scan window 14 or could adversely affect scale performance. The two-plane weigh platter 6 may be fabricated from a single piece of material (preferably metal) or may be assembled from multiple pieces provided it comprises a single rigid structure as described herein.

One variation of this embodiment has a horizontal extension 40 of the weigh platter rigidly connected to the top edge 42 of the vertical platter section 38 of the weigh platter. This extension of the weigh platter 6 serves to further inhibit passage of debris between the vertical scanner window 10 and the vertical platter window 8 which would obstruct the vertical scanner window 10. The extension may be further extended downward behind the back surface 44 of the scanner housing portion 46 (see downward extension 43 in FIG. 5). The extended weigh platter may be fabricated in a single piece structure or assembled from multiple pieces

4

provided it comprises a rigid overall structure with the sealed connection 35.

The horizontal platter window 12 is preferably constructed of a material which is shatter resistant and wear resistant such as sapphire, wear resistant coated glass (such as the wear-resistant glass with diamond-like coating described in U.S. Pat. No. 5,594,231), or tin-oxide since items being scanned are often dropped onto or dragged across the horizontal window 12. The vertical platter window 8 is generally subject to less impact and scratching action and likely would not require quite as an expensive material as the horizontal window, but should still preferably be constructed to have some scratch and impact resistance. Since the scanner housing windows 10, 14 are protected from impact by the weigh platter windows 8, 12, they need not be constructed from expensive scratch resistant material. Alternatively, though the scanner internals would be somewhat more exposed, the housing windows 10, 14 may comprise mere openings (i.e., no glass covers) since the platter windows 8, 12 alone may provide adequate protection for internal components.

In FIGS. 2 and 4 the load cell 4 is shown integrally mounted on the top of the horizontal scanner housing portion 24, and is rigidly but removably connected to the bottom 48 of the two-plane weigh platter 6. The integral mounting of the load cell reduces the overall bulk of the two-plane scanner/weighing apparatus 1. In its preferred construction, the spiderless weigh platter 6 is constructed in a manner that [insures] ensures rigidity sufficient to bear the weight of an object being weighed and sufficient to maintain its two-plane geometry and prevent the vertical scanner housing portion 46 from interfering with the weighing process. One such construction would be the incorporation of stiffening ribs 50 into the structure of the platter 6.

Also depicted in FIGS. 2 and 4 is a coupling mechanism for rigidly but removably connecting the two-plane weigh platter 6 to the load cell 4, comprising a pair of precision machined pins 52 attached to the bottom 48 of the two-plane weigh platter 6, and a mating set of precision machined holes 54 in the load cell 4. By such a construction, the weigh platter 6 is readily removable by pulling up on the platter, the pins 52 sliding out of the holes 54. Any rigid but removable coupling mechanism may be substituted for the pin/hole mechanism depicted here.

The two-plane weight platter embodiment solves two of the problems discussed in the background section. First, the vertical section 38 of the weigh platter 6 at the side adjacent the vertical scan window 10, being connected to and moving with the horizontal section 20, prevents debris from falling therebetween and under the weigh platter 6 on that side and obstructing the horizontal scan window. Second, the vertical section 38 of the weigh platter 6 prevents the object being weighed from coming into contact with the vertical scan window 10, so the vertical scan window 10 will not interfere with the weighing process.

The weigh platter preferably has bottom extensions which extend below the planar surface of the window 14 to prevent debris or liquids from contacting the window 14. Moreover, the side surfaces (i.e. both lateral sides and the side next to the checker) of the horizontal scan housing portion 24 are sloped to channel debris and liquids down and away from the window 14. The sides of the weigh platter 6 (such as the stiffening ribs 50) may extend downwardly to provide additional baffles in further inhibit debris or liquids from contacting the window 14. Alternatively, the downwardly extending sides may be disposed in a trough and be provided

5

with additional spill control and air gap maintenance thereby as disclosed in U.S. Pat. No. 5,410,108, which is incorporated by reference.

The multiple plane weigh platter **6** also facilitates weighing of oversized objects. With existing weigh platters, if the length of an object to be weighed exceeds the length of the horizontal weigh platter, the object may come in contact with the housing or the counter resulting in inaccurate weight measurement. FIG. **5** illustrates the apparatus **1** with an oversized object **75** being weighed on the multi-plane platter **6**. One end of the object rests on the horizontal sections **20** and the other end rests on the vertical section **38**. Were the object flexible, such as a large bag of produce, the bag may even be laid over the vertical housing portion **46** on the horizontal extension **40** of the weigh platter or even onto the downward extension **43** behind the back surface **44** of the vertical scanner housing portion **46**.

To achieve potential reduction in size and material/manufacture cost, the load cell **4** may be incorporated directly into an upper section of the horizontal scanner housing portion **24**, instead of comprising a separate sub-assembly. The weigh platter **6** is borne by the load cell **4** either directly or via a spider such as in alternate embodiments described below. In so called "spiderless" designs, the weigh platter itself is made sufficiently rigid to bear the object being weighed. By combining the weighing device and scanner in a single unit the overall size of the scanner/weighing device combination may be reduced compared to earlier devices at potentially reduced cost of material and/or manufacture.

The apparatus **1** of FIGS. **1-4** centrally locates the load cell **4** between the vertical section **38** and the horizontal section **20**. FIG. **6** illustrates an alternate apparatus **101** in which the load cell **105** (with the holes **154**, **154** for the pins) is located at an opposite end of the horizontal scanner housing portion **124** of the scanner **102**. The weigh platter **106** is more greatly cantilevered, but may be designed to fall within load cell specifications.

Though a single load cell and pin mounting design may be preferred, the apparatus may be configured with multiple load cells. FIG. **6** also illustrates another alternate embodiment comprising multiple load cells **104a**, **104b**, **104c**, **104d** spaced about the horizontal portion of the scanner **102**. Depending upon particular design constraints, multiple load cells may not require pin connection such as preferred for the single load cell design previously described.

Alternatively, a spider may be rigidly but removably connected to the load cell, which in turn bears the two-plane weigh platter. FIG. **7** illustrates another alternate apparatus **201** having an integral spider **260** having a single load cell **205**. In this alternate embodiment, though the spider **260** provides additional stiffness to reduce the rigidity required of the weigh platter itself, the two-plane weigh platter **206** should still possess rigidity sufficient to maintain its two-plane geometry and prevent the vertical scanner section **246** of the scanner **202** from interfering with the weighing process. In another alternative embodiment, the load cell **205**, spider **260**, and two-plane weigh platter **206** may comprise a separate subassembly from the horizontal scanner housing portion **24** and vertical scanner housing portion **246**. In this embodiment, the load cell **205** is placed between the vertical housing portion **246** and the horizontal housing portion and rigidly connected to the spider by suitable horizontal or vertical support members.

Alternatively, the load cell upon which the spider is mounted may be placed next to or below the scanner housing

6

portions and rigidly connected to the spider by suitable horizontal or vertical support members, respectively. FIG. **8** illustrates another alternate apparatus **301** having an integral spider **360** having a single load cell **305**. In this alternate embodiment, the two-plane weigh platter **306** possesses rigidity sufficient to maintain its two-plane geometry and prevent the vertical scanner section **346** of the scanner **302** from interfering with the weighing process. The load cell **305** is placed on an end of the horizontal scan housing portion **324** opposite to the vertical housing portion **346** (i.e. on the checker side).

Spider designs may also incorporate multiple load cells. In the apparatus **401** of FIG. **9**, separate spider legs **460**, **462** (they could be connected as a single spider as in FIG. **8** for example) are mounted on load cells **405**, **404** respectively. The spider legs **460**, **462** provide additional stiffness to reduce the rigidity required of the weigh platter **406** itself, but the two-plane weigh platter **206** should still possess rigidity sufficient to maintain its two-plane geometry and prevent the vertical scanner section **446** of the scanner **402** from interfering with the weighing process.

In each of the above embodiments, the load cell may be located within the scanner [envelop] *envelope* (such as load cell **205** in FIG. **7**) or outside such as load cell **305** as illustrated in FIG. **8**. Similarly, the spider may be incorporated outside the scanner [envelop] *envelope* (such as spider **360** in FIG. **8**) or alternately inside the scanner [envelop] *envelope* (such as spider **260** in FIG. **7**) depending upon the specific apparatus configuration.

The disclosed embodiments of the multiple plane weigh platter may be combined with any suitable weighing device and with any multiple plane optical reading device without altering the concept of the present invention. Alternately, the platter may merely comprise a cover for a multi-plane scanner (i.e. a scanner having no scale). In the "no-scale" embodiment, the multi-plane cover would still provide spill and mechanical protection for the internal components, but may not require as stiff a construction as does the weigh platter scale version.

The embodiments disclosed may be modified in various ways without departing from the fundamental inventive concept presented hereinabove. Further modifications may include, but are not limited to: the number of scan planes and weigh platter planes; the method of manufacturing the weigh platter; the mechanical connection between the weigh platter and the weighing device; the particular nature of the weighing device; and the positioning of the weighing device (integral to the scanner or as a separate subassembly).

Though the multi-plane weigh platter has been shown and described with respect to a laser scanner such as the Spectra-Physics MAGELLAN™ scanner, it is intended that scanner upon which the weigh platter is constructed may comprise any sort of data reading device including scanning laser beam(s), CCD, video, LED, or the like.

Though the multi-plane weigh platter has been described as useful for multi-plane scanner, it may also be used in a single plane (either horizontal or vertical) that may have additional components. Envision for example a scanner/scale **1** of FIG. **1** having only a vertical window and no horizontal window. A multi-plane weigh platter for such a scanner/scale would only require a vertical window (the horizontal portion could be entirely opaque).

Though the weigh platter has been described with respect to dual-plane scanners, additional scan planes can be accommodated. For example in FIG. **10**, a three-plane apparatus **501** is illustrated having two vertical scan housing portions

546, 545 and a horizontal scan housing portion 524. Such a device may have one, two or three windows through which scanning may be accomplished. The multi-plane cover or weigh platter 506 has two vertical sections 538, 539 and a horizontal section 520. Each platter section has a window (if required) corresponding to each respective scan housing window. The vertical platter sections may include horizontal extensions 540, 541 and further include downwardly extending vertical extensions 543, 544 if desired to provide further protection.

Thus, a multiple plane optical scanning system has been shown and described herein which incorporates a multiple plane spiderless weigh platter and an integrally mounted load cell. Though certain examples and advantages have been disclosed, further advantages and modifications may become obvious to one skilled in the art from the disclosures herein. The invention therefore is not to be limited except in the spirit of the claims that follow.

What is claimed is:

1. A multi-plane optical reader comprising
 - a lower housing portion with a horizontal window;
 - a first upper housing portion with a first vertical window positioned above and to one side of the lower housing portion;
 - a removable external cover having (a) a horizontal section, including a window of transparent material disposed over the horizontal window of the lower housing portion, (b) a first vertical section rigidly connected to the horizontal section, the first vertical section including a window of transparent material disposed adjacent the first vertical window of the first upper housing portion.
2. A multi-plane optical reader according to claim 1 further comprising
 - a second upper housing portion with a second vertical window positioned above and to one side of the lower housing portion on a side opposite to the first upper housing portion,
 wherein the external cover includes a second vertical section attached to the first vertical section and extending over the second upper housing portion, and wherein the first vertical section, the second vertical section and the horizontal section are constructed with a one-piece integral frame.
3. An optical reader comprising
 - a lower housing portion with a horizontal surface;
 - a first upper housing portion with a first vertical opening positioned above and to a first side of the lower housing portion;
 - a second upper housing portion with a second vertical opening positioned above and to a second side of the lower housing portion opposite to the first upper housing portion;
 - a removable external cover having (a) a central horizontal cover section disposed over the lower housing portion, (b) a first upper cover section integral with the central cover section and disposed in front of the first upper housing portion, (c) a second upper cover section integral with the central cover section and disposed in front of the second upper housing portion.
4. An optical reader according to claim 3 wherein the central horizontal cover section, the first upper cover section, and the second upper cover section are constructed with a one-piece integral frame.
5. An optical reader according to claim 3 wherein the first upper cover section includes a cover portion extending over a top of the first upper housing portion.

6. An optical reader according to claim 3 wherein the external cover comprises a weigh platter.

7. An optical reader according to claim 6 further comprising

5 a spider connected to at least one load cell for supporting the removable external cover.

8. An optical reader according to claim 7 further comprising a coupling mechanism for rigidly but removably connecting the weigh platter to the load cell.

10 9. An optical reader according to claim 8 wherein the coupling mechanism comprises a pair of precision machined pins attached to the weigh platter and a mating set of precision machined holes in the load cell.

15 10. An optical reader according to claim 3 wherein the external cover comprises a weigh platter, the weigh platter being constructed and arranged with sufficient rigidity such that an object is accurately weighed when placed with one end on the central cover section and one end on the first upper cover section.

20 11. An optical reader comprising

- a lower housing portion [having a horizontal surface];
- an upper housing portion with a vertical window positioned above and to one side of the lower housing portion;
- 25 a weigh platter [disposed over the lower housing portion and] having (a) a horizontal section [extending] positioned over the [horizontal surface] lower housing portion (b) a vertical section rigidly connected to the horizontal section, the vertical section including a window of transparent material.

30 12. An external cover for an optical reader, the optical reader having a horizontal surface and a vertical scan window disposed to one side of the horizontal surface, said external cover comprising

35 a horizontal section constructed and arranged for positioning over the horizontal surface of the optical reader; and

40 a vertical section rigidly connected to said horizontal section, said vertical section including a window of transparent material constructed and arranged for positioning adjacent the vertical scan window;

wherein said external cover is separately removable from the optical reader.

45 13. An external cover according to claim 12, wherein said vertical section and said horizontal section are sealed together to prevent passage of debris therebetween.

14. An external cover according to claim 12 wherein the horizontal section and the vertical section are constructed with a one-piece integral frame.

50 15. An external cover according to claim 12 wherein the external cover comprises a weigh platter.

16. An external cover according to claim 15 further comprising

55 at least one load cell;

a spider connected to at the least one load cell for supporting the removable external cover.

17. An external cover according to claim 16 further comprising a coupling mechanism for rigidly but removably connecting the spider to the load cell.

60 18. An external cover according to claim 15 further comprising at least one load cell and a coupling mechanism for rigidly but removably connecting the weigh platter to the load cell.

65 19. An external cover according to claim 12 wherein the external cover comprises a weigh platter, the weigh platter being constructed and arranged with sufficient rigidity such

that an object is accurately weighed when placed with one end on the central cover section and one end on the first upper cover section.

20. An optical reader comprising

a reader housing including a lower housing portion and a first upper housing portion, the first upper housing portion having a first vertical window positioned above and to one side of the lower housing portion;

a scan generating mechanism for projecting a scan pattern out through the first vertical window and into a scan region;

a removable weigh platter having (a) a horizontal section disposed over the lower housing portion, (b) a first vertical section rigidly connected to the horizontal section, the first vertical section including an opening disposed adjacent the first vertical window through which the scan pattern from the vertical window is passed.

21. An optical reader according to claim **20** wherein the horizontal and vertical sections of the weigh platter are constructed and interconnected with sufficient rigidity such that an object is accurately weighed when placed with one end on the horizontal section and one end on the first vertical section.

22. An optical reader according to claim **20** wherein the horizontal and vertical sections of the weigh platter are constructed and interconnected with sufficient rigidity such that weight of an object placed with one end on the horizontal section and one end on the first vertical section does not cause deformation of the weigh platter to a degree that the first upper housing portion would interfere with movement of the weigh platter during weighing.

23. An optical reader according to claim **20** wherein the weigh platter comprises stiffening ribs for providing structural rigidity.

24. An optical reader according to claim **20** further comprising

at least one load cell;

a spider connected to at the least one load cell for supporting the weigh platter.

25. An optical reader according to claim **20** wherein the weigh platter is readily removable from the optical reader by pulling up on the platter.

26. An optical reader according to claim **20** further comprising at least one load cell and a coupling mechanism for rigidly but removably connecting the weigh platter to the load cell.

27. An optical reader according to claim **20** wherein the weigh platter further having (c) a second vertical section rigidly connected to the horizontal section, the second vertical section being disposed on a side of the weigh platter opposite the first vertical section.

28. An optical reader according to claim **27** wherein the horizontal section and the vertical sections of the weigh platter are constructed and interconnected with sufficient rigidity such that an object is accurately weighed when placed with one end on the horizontal section and one end on a vertical section.

29. A weigh platter for an optical reader, the optical reader having a horizontal surface and a vertical scan window disposed to one side of the horizontal surface, said weigh platter comprising

a horizontal section constructed and arranged for positioning over the horizontal surface of the optical reader; and

a first vertical section rigidly connected to said horizontal section, said vertical section including an

opening constructed and arranged for permitting a scan pattern emanating out from said vertical scan window to pass through said opening.

30. A weigh platter according to claim **29** wherein the horizontal and vertical sections are constructed and arranged with sufficient rigidity such that an object is accurately weighed when placed with one end on the horizontal section and one end on the vertical section.

31. A weigh platter according to claim **29** wherein the opening of the vertical section comprises a window.

32. A weigh platter according to claim **29** further comprising

a second vertical section rigidly connected to the horizontal section, the second vertical section being disposed on a side of the weigh platter opposite the first vertical section.

33. A weigh platter according to claim **32** wherein the first and second vertical sections are constructed and interconnected with the horizontal section with sufficient rigidity such that an object is accurately weighed when placed with one end on the horizontal section and one end on a vertical section.

34. An optical reader comprising

a reader housing including a lower housing portion and a first upper housing portion, the first upper housing portion having a first vertical window positioned above and to one side of the lower housing portion;

a scan generating mechanism for projecting a scan pattern out through the first vertical window and into a scan region;

a removable weigh platter having (a) a horizontal section disposed over the lower housing portion, and (b) a first vertical extension connected to the horizontal section and extending vertically upward from a top surface of the horizontal section, wherein the horizontal section and the vertical extension of the weigh platter are constructed and interconnected such that an object is accurately weighed when placed with one end on the horizontal section and one end on the first vertical extension.

35. An optical reader according to claim **34** wherein first vertical extension has an opening between a top portion of the vertical extension and a top surface of the horizontal section of the weigh platter.

36. An optical reader according to claim **35** wherein the opening in the first vertical extension comprises a window.

37. An optical reader according to claim **34** wherein the weigh platter is readily removable from the optical reader by pulling up on the platter.

38. An optical reader according to claim **34** further comprising at least one load cell and a coupling mechanism for rigidly but removably connecting the weigh platter to the load cell.

39. An optical reader according to claim **34** wherein the vertical extension is disposed on a side of the weigh platter proximate the first vertical window.

40. An optical reader according to claim **34** wherein the vertical extension is disposed on a side of the weigh platter opposite the first vertical window.

41. An optical reader according to claim **34** wherein the reader housing further comprises a second upper housing portion having a second vertical window positioned above and to one side of the lower housing portion opposite the first upper housing portion, wherein the weigh platter having a second vertical extension, wherein the first vertical extension is disposed on a side of the weigh platter proximate the second vertical window and the second vertical extension is

11

disposed on a side of the weigh platter proximate the first vertical window.

42. An optical reader comprising horizontal housing portion including a horizontally-oriented scan window, a weigh platter disposed over the horizontal housing portion, the weigh platter comprising a horizontal section constructed and arranged for positioning over the horizontally-oriented scan window; and a vertical extension connected to said horizontal section, said vertical extension including an opening proximate a top surface of the horizontal section, wherein the vertical extension and the horizontal section are constructed and interconnected such that an object is accurately weighed when placed with one end on the horizontal section and one end on the vertical extension.

43. A weigh platter according to claim 42 wherein the opening of the vertical extension comprises a window.

44. *An external cover for an optical reader, the optical reader having a weighing apparatus, a horizontal housing portion containing an horizontal scan window, and a vertical housing portion containing a vertical scan window, the external cover comprising:*

a vertical section supported on the weighing apparatus and including a first window disposed in front of the vertical scan window; and

a horizontal section supported on the weighing apparatus and including a second window disposed over the horizontal scan window.

45. *An external cover according to claim 44 wherein the vertical section is constructed and arranged such that an item is accurately weighed when placed with one end on the horizontal section and one end on the vertical section.*

46. *An external cover according to claim 44 wherein the vertical section is constructed and arranged so as to prevent interference from the vertical housing portion of the optical reader during weighing of an item placed on the horizontal section and in contact with the vertical section.*

47. *An external cover according to claim 44 wherein the weighing apparatus includes a load cell, and further comprising a coupling mechanism for rigidly but removably connecting the vertical section to the load cell.*

48. *An external cover according to claim 47 wherein the coupling mechanism includes a pair of pins and a mating set of precision machined holes.*

49. *An external cover according to claim 48 wherein the precision machined holes are formed in the load cell.*

50. *An external cover according to claim 44 wherein together the vertical section and the horizontal section comprise a two-plane weigh platter.*

51. *An external cover according to claim 44 wherein the vertical section is connected to the horizontal section.*

52. *An external cover according to claim 44 wherein the vertical section includes a horizontal extension extending over a top of the vertical housing portion.*

53. *An optical reader comprising:*

a housing including (a) a vertical housing portion including a vertically-oriented scan window and (b) a horizontal housing portion;

a weighing apparatus disposed in the housing;

a horizontal weigh platter supported by the weighing apparatus and disposed over the horizontal housing portion; and

a vertical window section coupled to the weighing apparatus and disposed in front of the vertical housing

12

portion so that an object placed on the horizontal weigh platter and contacting the vertical window section is in part weighed by the vertical window section.

54. *An optical reader according to claim 53 wherein the vertical window section is constructed and arranged so as to prevent interference from the vertical housing portion during weighing.*

55. *An optical reader according to claim 53 wherein the vertical window section is constructed and arranged such that an item is accurately weighed when placed on the horizontal weigh platter and in contact with the vertical window section.*

56. *An optical reader according to claim 53 wherein the weighing apparatus comprises at least one load cell.*

57. *An optical reader according to claim 53 further comprising a coupling mechanism for rigidly but removably connecting the vertical window section to the weighing apparatus.*

58. *An optical reader according to claim 57 wherein the coupling mechanism includes a pair of pins and a mating set of precision machined holes.*

59. *An optical reader according to claim 53 wherein the vertical window section is connected to the horizontal weigh platter.*

60. *An optical reader according to claim 53 wherein the vertical window section includes a horizontal extension extending over a top of the vertical housing portion.*

61. *An optical reader comprising:*

a housing including (a) a horizontal housing portion with a horizontally-oriented scan window and (b) a vertical housing portion including a vertically-oriented scan window;

a weighing apparatus disposed in the housing;

a horizontal weigh platter section constructed and arranged for positioning over the horizontally-oriented scan window, the horizontal weigh platter section supported on the weighing apparatus; and

a vertical weigh platter section including a window, constructed and arranged for positioning in front of the vertically-oriented scan window, the vertical weigh platter section being supported on the weighing apparatus,

wherein the vertical weigh platter section is constructed and arranged such that an object is accurately weighed when placed on the horizontal weigh platter section and in contact with the vertical weigh platter section.

62. *An optical reader according to claim 61 wherein the vertical weigh platter section is connected to the horizontal weigh platter section.*

63. *An optical reader according to claim 61 further comprising a coupling mechanism including a pair of pins and a mating set of precision machined holes for rigidly but removably connecting the vertical weigh platter section to the weighing apparatus.*

64. *A weighing system for a scanner-scale, the scanner-scale having a housing with vertical and horizontal scan surfaces, the weighing system comprising:*

a weighing apparatus disposed in the housing; and

a weigh platter supported by the weighing apparatus for accepting and weighing items placed thereon, the weigh platter comprising:

a horizontal weigh platter section disposed over the horizontal scan surface and supported by the weighing apparatus, and

a vertical window section disposed in front of the vertical scan surface and supported by the weighing apparatus.

65. A weighing system according to claim 64 wherein the vertical window section is supported by the weighing apparatus such that an item is accurately weighed when placed on the horizontal weigh platter section and in contact with the vertical window section.

66. A weighing system according to claim 65 wherein the weighing apparatus comprises at least one load cell, and the weighing system further comprises a coupling mechanism for rigidly but removably connecting the vertical window section to the load cell.

67. A weighing system according to claim 66 wherein the counting mechanism includes a pair of pins and a mating set of precision machined holes.

68. A weighing system according to claim 67 wherein the precision machined holes are formed in the load cell.

69. A weighing system according to claim 64 wherein the vertical window section is connected to the horizontal weigh platter section.

70. A method of weighing items on a scanner-scale, the scanner-scale having vertical and horizontal scan surfaces, comprising the steps of:

providing a weighing apparatus for accepting items being weighed to be placed on a weigh platter disposed over the horizontal scan surface;

providing a vertical window in front of the vertical scan surface; and

supporting the vertical window on the weighing apparatus such that an item placed on the weigh platter is accurately weighed when contacting the vertical window.

71. A method according to claim 70 wherein the supporting of the vertical window on the weighing apparatus includes supporting the vertical window via the weigh platter.

72. In a multi-plane optical reader having a first scan window oriented in a generally horizontal plane, a second scan window oriented transversely to and adjacent to the first scan window, and a weighing device, an improved weigh platter for supporting an object being weighed, comprising:

a first platter section supported by the weighing device in substantially horizontal orientation, the first platter section including a first platter window positioned over the first scan window; and

a second platter section supported by the weighing device, the second platter section extending transversely to the first platter section and including a second platter window disposed in front of the second scan window, the second platter section spaced apart from the second scan window to prevent the object from contacting the second scan window, thereby preventing the second scan window from interfering with weighing of the object.

73. A weigh platter according to claim 72 wherein the weighing device includes a load cell, and further comprising a coupling mechanism for rigidly but removably connecting the second platter section of the load cell.

74. A weigh platter according to claim 72 wherein the second platter section is connected to the first platter section.

75. A weigh platter for an optical reader including a housing having a horizontal housing portion and a vertical housing portion, the vertical housing portion including a vertical scan window, comprising:

a horizontal platter section adapted to be positioned over the horizontal housing portion; and

a vertical platter section adapted to be installed on the optical reader adjacent to and spaced apart from the vertical housing portion so that the vertical platter section extends transversely to the horizontal platter section, the vertical platter section including a vertical platter window that is positioned in front of the vertical scan window when the vertical platter section is installed on the optical reader.

76. A weigh platter according to claim 75 wherein the vertical platter section is connected to the horizontal platter section.

77. A weigh platter according to claim 75 wherein the vertical platter section includes a cover portion sized to extend over a top of the vertical housing portion when the vertical platter section is installed on the optical reader.

78. A combination optical reader and weighing apparatus comprising:

a reader means for optically scanning an object from multiple directions including a generally horizontal scanning direction;

means for measuring an applied load; and

a weigh platter positioned over the reader means and supported by the means for measuring, the weigh platter including:

a horizontal first platter section, and

a second platter section positioned adjacent the first platter section and extending transversely to the first platter section, the second platter section including a platter window through which the reader means scans in the horizontal scanning direction.

79. A combination optical reader and weighing apparatus according to claim 78 wherein the means for measuring includes at least one load cell.

80. A combination optical reader and weighing apparatus according to claim 79 further comprising a coupling mechanism for rigidly but removably connecting the second platter section to the load cell.

81. A combination optical reader and weighing apparatus according to claim 80 wherein the coupling mechanism includes a pair of pins and a mating set of precision machined holes.

82. A combination optical reader and weighing apparatus according to claim 81 wherein the precision machined holes are formed in the load cell.

83. A combination optical reader and weighing apparatus according to claim 78 wherein the second platter section is connected to the first platter section.

84. A multi-plane scanner scale comprising:

a data reading device;

a housing positioned over the data reading device and including a vertical scan window through which the data reading device scans;

a weighing device; and

a weigh platter including:

a horizontal section, and

a vertical section including a vertical platter window disposed in front of the vertical scan window so that the data reading device scans the object through the vertical platter window, the vertical section supported by the weighing device so that an object placed on the weigh platter in contact with the vertical section is accurately weighed by the weighing device.

85. A multi-plane scanner scale according to claim 84 wherein the vertical section is connected to the horizontal section.

15

86. A removable external cover for an optical reader including a vertical scan window, a load cell, and a horizontal weigh platter, comprising:

a vertical section including a vertical platter window adapted to be disposed in front of the vertical scan window, the vertical section adapted to be supported by the load cell adjacent the horizontal weigh platter and the vertical scan window so as to maintain a separation between the vertical section and the vertical scan window when an object being weighed is placed in contact with the vertical section.

87. A removable cover according to claim 86 wherein the vertical section is connected to the horizontal weigh platter and supported on the load cell via the horizontal weigh platter.

88. A removable cover according to claim 86 further comprising a coupling mechanism for rigidly but removably connecting the vertical section to the load cell.

89. A weigh platter for an optical reader having a housing and a weighing device, the housing including a vertical portion having a vertically-oriented scan window through which the optical reader reads, the weigh platter comprising:

a horizontal section adapted to be supported by the weighing device; and

16

a vertical section adapted to be supported by the weighing device adjacent the horizontal section, the vertical section including a vertically-oriented platter window positioned in front of the vertically-oriented scan window when the vertical section is supported on the weighing device to thereby prevent an object being weighed from contacting the vertical portion of the housing.

90. A weigh platter according to claim 89 wherein the horizontal and vertical sections are adapted to be arranged on the optical reader such that an object resting against the vertical and horizontal sections is accurately weighed by the weighing device.

91. A weigh platter according to claim 89 wherein the vertical and horizontal sections are adapted to be manually installed on and removed from the optical reader.

92. A weigh platter according to claim 89 wherein the vertical section is connected to the horizontal section.

93. A weigh platter according to claim 89 further comprising a coupling mechanism for rigidly but removably connecting the vertical section to the weighing device.

* * * * *

UNITED STATES PATENT AND TRADEMARK OFFICE
CERTIFICATE OF CORRECTION

PATENT NO. : RE 40,071 E
APPLICATION NO. : 10/447746
DATED : February 19, 2008
INVENTOR(S) : Svetal et al.

Page 1 of 2

It is certified that error appears in the above-identified patent and that said Letters Patent is hereby corrected as shown below:

Column 2

Line 21, change "decreases" to --decrease--.

Line 34, change "simple" to --simply--.

Column 3

Line 6, add "the" before "apparatus".

Line 8, change "alterate" to --alternate--.

Line 43, change "front 32 edge" to --front edge 32--.

Column 4

Line 65, change "baffles in" to --baffles to--.

Column 5

Line 12, change "sections" to --section--.

Line 48, change "hears" to --bears--.

Column 6

Line 62, delete "a" first occurrence.

Column 7

Line 45, change "with" to --having--.

Column 8

Line 56, change "at the" to --the at--.

Column 9

Line 39, change "at the" to --the at--.

Line 49, change "having" to --has--.

UNITED STATES PATENT AND TRADEMARK OFFICE
CERTIFICATE OF CORRECTION

PATENT NO. : RE 40,071 E
APPLICATION NO. : 10/447746
DATED : February 19, 2008
INVENTOR(S) : Svetal et al.

Page 2 of 2

It is certified that error appears in the above-identified patent and that said Letters Patent is hereby corrected as shown below:

Column 11

Line 22, change "an" to --a--.

Column 13

Line 12, change "counting" to --coupling--.

Line 57, change "of" to --to--.

Signed and Sealed this

Sixteenth Day of December, 2008

A handwritten signature in black ink that reads "Jon W. Dudas". The signature is written in a cursive style with a large, stylized initial "J".

JON W. DUDAS

Director of the United States Patent and Trademark Office