



US00RE40049E

(19) **United States**  
(12) **Reissued Patent**  
**Li**

(10) **Patent Number: US RE40,049 E**  
(45) **Date of Reissued Patent: Feb. 12, 2008**

(54) **PRECOOLED CRYOGENIC ABLATION SYSTEM**

4,951,471 A \* 8/1990 Sakitani et al. .... 62/51.2  
4,990,412 A \* 2/1991 Hersey ..... 429/8

(75) Inventor: **Hong Li**, San Diego, CA (US)

(Continued)

(73) Assignee: **AMS Research Corporation**,  
Minnetonka, MN (US)

FOREIGN PATENT DOCUMENTS

(21) Appl. No.: **11/412,250**

GB 2283678 A \* 5/1995  
WO WO95/13025 \* 5/1995  
WO WO95/19738 \* 7/1995  
WO WO 95/15093 \* 4/1999  
WO WO99/15093 \* 4/1999  
WO WO99/57494 \* 11/1999  
WO WO00/42932 \* 7/2000

(22) Filed: **Apr. 26, 2006**

**Related U.S. Patent Documents**

Reissue of:

(64) Patent No.: **6,237,355**  
Issued: **May 29, 2001**  
Appl. No.: **09/344,423**  
Filed: **Jun. 25, 1999**

OTHER PUBLICATIONS

U.S. Applications:

(62) Division of application No. 10/446,390, filed on May 28, 2003.

Chang, Z.; "Development of a high Performance Multiprobe Cryosurgical Device", Sep. 1994; Biomedical Instrumentation and Technology: pp. 383-390.\*

Little, W.; Advances in Joule-Thomson Colling; pp. 1-10; place and date of publication unknown.\*

Little, W.; Microminiature Refrigeration: Jun. 1983; Rev. Sci. Instrum. 55(5); pp. 661-680.\*

Little, W.; Microminiature Refrigerators for Joule-Thomson Cooling of Electronic Chips and Devices; 1990; Advances in Cryogenic Engineering vol. 35; pp. 1325-1333.\*

(51) **Int. Cl.**

**F25D 3/00** (2006.01)  
**F25B 9/00** (2006.01)  
**F25B 7/00** (2006.01)

*Primary Examiner*—William C Doerrler

(74) *Attorney, Agent, or Firm*—Baker & McKenzie LLP

(52) **U.S. Cl.** ..... **62/293**; 62/6; 62/114;  
62/335; 606/20; 606/22; 606/25

(57) **ABSTRACT**

(58) **Field of Classification Search** ..... 62/293,  
62/6, 114, 335; 606/20, 22, 25  
See application file for complete search history.

A method and apparatus for using a secondary refrigerant to precool and liquefy a primary refrigerant, then vaporizing and expanding the primary refrigerant to cool a cold tip of a cryosurgical instrument for ablation of biological tissue, such as cardiovascular tissue, in particular endocardiac tissue and tissue inside a cardiac blood vessel. The secondary refrigerant has a critical temperature above the critical temperature of the primary refrigerant, and a cooling temperature below the critical temperature of the primary refrigerant, thereby facilitating the use of the precooling step to provide liquid primary refrigerant in an operating room environment in which the primary refrigerant could not otherwise be provided in the liquid phase.

(56) **References Cited**

U.S. PATENT DOCUMENTS

2,991,633 A \* 7/1961 Simon ..... 62/51.2  
3,048,021 A \* 8/1962 Frame et al. .... 62/51.2  
3,401,533 A \* 9/1968 Bradley ..... 62/51.2  
3,415,078 A \* 12/1968 Liston ..... 62/51.2  
3,431,750 A \* 3/1969 Lefranc ..... 62/51.2  
3,696,813 A \* 10/1972 Wallach ..... 606/26  
4,829,785 A \* 5/1989 Hersey ..... 62/467  
4,840,043 A \* 6/1989 Sakitani et al. .... 62/51.2  
4,875,346 A \* 10/1989 Jones et al. .... 62/467

**3 Claims, 1 Drawing Sheet**

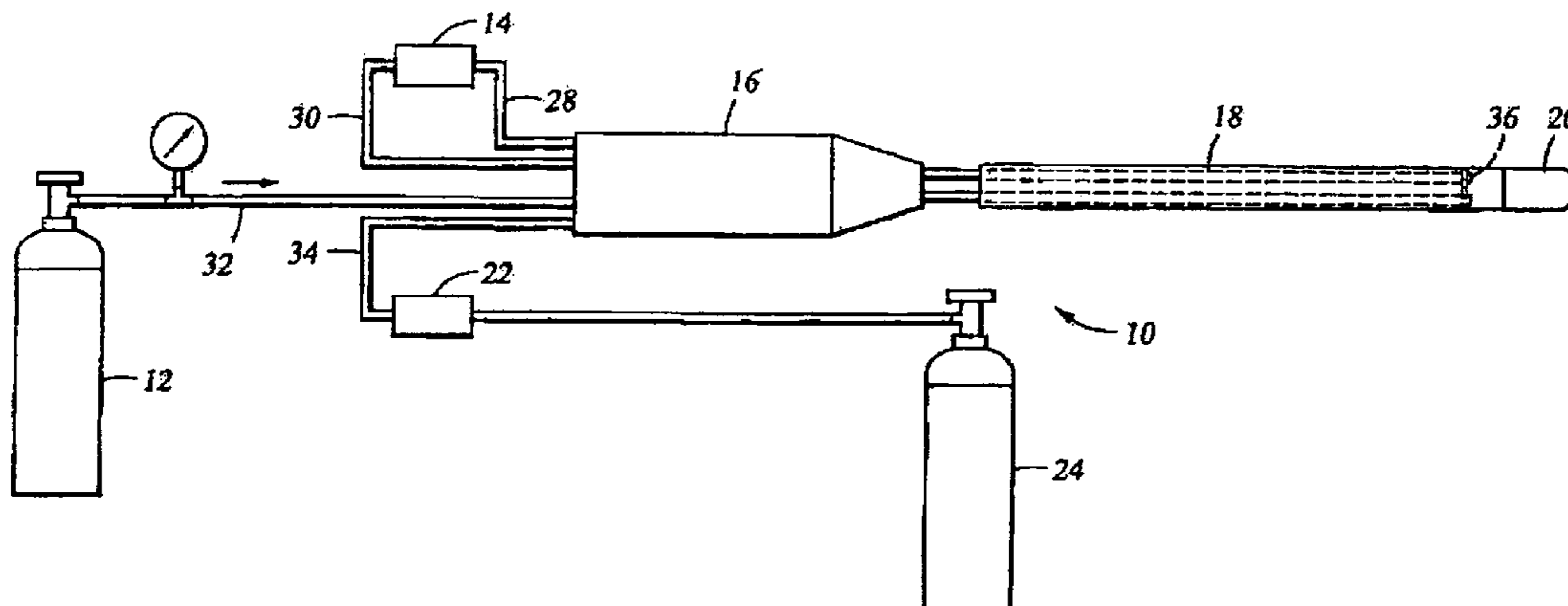

# US RE40,049 E

Page 2

---

## U.S. PATENT DOCUMENTS

5,037,431	A	*	8/1991	Summers et al.	.....	606/131	5,617,739	A	*	4/1997	Little	.....	62/619
5,063,747	A	*	11/1991	Jones et al.	.....	62/46.1	5,724,832	A	*	3/1998	Little et al.	.....	62/613
5,157,938	A	*	10/1992	Bard et al.	.....	62/335	5,758,505	A	*	6/1998	Dobak et al.	.....	62/6
5,207,674	A	*	5/1993	Hamilton	.....	606/20	5,759,182	A	*	6/1998	Varney et al.	.....	606/21
5,275,595	A	*	1/1994	Dobak, III	.....	606/23	5,807,391	A	*	9/1998	Wijkamp	.....	606/23
5,595,065	A	*	1/1997	Boiarski et al.	.....	62/222	6,592,577	B2	*	7/2003	Abboud et al.	.....	606/22
5,603,221	A	*	2/1997	Maytal	.....	62/51.2	6,635,053	B1	*	10/2003	Lalonde et al.	.....	606/22

\* cited by examiner

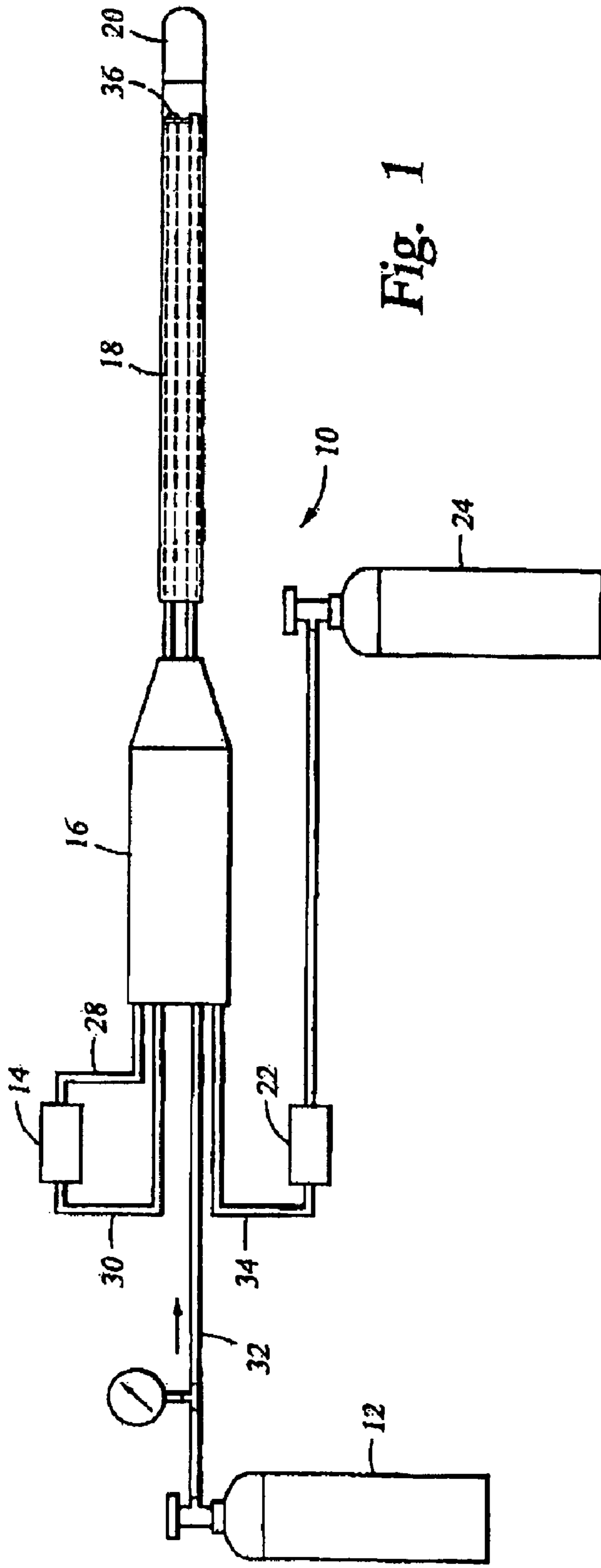

Fig. 1

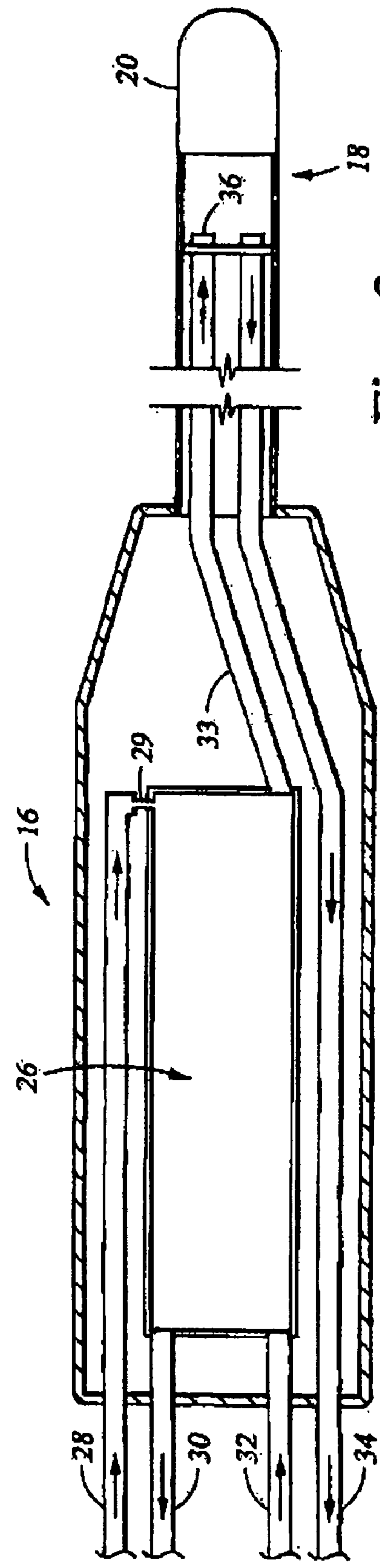

Fig. 2

## PRECOOLED CRYOGENIC ABLATION SYSTEM

**Matter enclosed in heavy brackets [ ] appears in the original patent but forms no part of this reissue specification; matter printed in italics indicates the additions made by reissue.**

*Notice: More than one reissue application has been filed for the reissue of U.S. Pat. No. 6,237,355. The reissue applications are application Ser. Nos. 11/412,250 (the present application) and 10/446,390 (which is fully incorporated herein by reference). The present application Ser. No. 11/412,250, is a divisional of reissue application Ser. No. 10/446,390 and also a reissue of U.S. Pat. No. 6,237,355.*

### CROSS REFERENCE TO RELATED APPLICATIONS

Not Applicable

### STATEMENT REGARDING FEDERALLY SPONSORED RESEARCH OR DEVELOPMENT

Not Applicable

### BACKGROUND OF THE INVENTION

#### 1. Field of the Invention

This invention is in the field of cooling biological tissues to very low temperatures, for treatment of medical conditions, as in cryosurgery.

#### 2. Background Information

It is desirable to be able to selectively cool miniature discrete portions of biological tissue to very low temperatures in the performance of cryosurgery, without substantially cooling adjacent tissues of the organ. Cryosurgery has become an important procedure in medical, dental, and veterinary fields. Particular success has been experienced in the specialties of gynecology and dermatology. Other specialties, such as neurosurgery and urology, could also benefit from the implementation of cryosurgical techniques, but this has only occurred in a limited way. Unfortunately, currently known cryosurgical instruments have several limitations which make their use difficult or impossible in some such fields. Specifically, known systems can not achieve the necessary temperature and cooling power to optimally perform cryosurgical ablation, such as in cardiac ablation to correct arrhythmia.

In the performance of cryosurgery, it is typical to use a cryosurgical application system designed to suitably freeze the target tissue, thereby destroying diseased or degenerated cells in the tissue. The abnormal cells to be destroyed are often surrounded by healthy tissue which must be left uninjured. The particular probe, catheter, or other applicator used in a given application is therefore designed with the optimum shape, size, and flexibility or rigidity for the application, to achieve this selective freezing of tissue. Where a probe or catheter is used, the remainder of the refrigeration system must be designed to provide adequate cooling, which involves lowering the operative portion of the probe to a desired temperature, and having sufficient power or capacity to maintain the desired temperature for a given heat load. The entire system must be designed to place the operative portion of the probe or catheter at the location of the tissue to be frozen, without having any undesirable effect on other organs or systems.

It is an object of the present invention to provide a method and apparatus for precooling a primary loop high pressure refrigerant to a point below its critical temperature, to liquefy the primary refrigerant, with a secondary loop refrigeration cycle. This allows the use of a liquid primary refrigerant having a critical temperature below the operating room temperature, in order to achieve the lower temperature possible with such a primary refrigerant.

### BRIEF SUMMARY OF THE INVENTION

The present invention comprises a miniature refrigeration system, including a method for operating the system, including precooling of the primary high pressure refrigerant below its critical temperature, to liquefy the primary refrigerant, with a secondary refrigeration cycle using a second refrigerant with a higher critical temperature, to maximize the available cooling power of the primary refrigerant, and to achieve the lowest possible temperature.

The cooling power is an important design parameter of a cryosurgical instrument. With greater cooling power, more rapid temperature decreases occur, and lower temperatures can be maintained at the probe tip during freezing. This ultimately leads to greater tissue destruction. The power of a J-T cryosurgical device is a function of the enthalpy difference of the primary refrigerant and the mass flow rate. Pre-cooling a refrigerant below its critical temperature and liquefying the refrigerant will increase the enthalpy difference available for cooling power.

An example of a suitable primary refrigerant is SUVA-95, a mixture of R-23 and R-116 refrigerants made by DuPont Fluoroproducts, of Wilmington, Del. SUVA-95 has a critical temperature of 287K, with cooling capacity at temperatures as low as 185K at one atmosphere. An example of a suitable secondary refrigerant is AZ-20, an R-410a refrigerant made by Allied Signal of Morristown, N.J. AZ-20 has a critical temperature of 345K, with cooling capacity at temperatures as low as 220K at one atmosphere.

The high pressure primary refrigerant is fed as a gas into a high pressure passageway within a primary-to-secondary heat exchanger. The primary-to-secondary heat exchanger can be a coiled tube heat exchanger or a finned tube heat exchanger. The liquid secondary refrigerant is vaporized and expanded into a low pressure passageway in the primary-to-secondary heat exchanger. Heat exchange between the low pressure secondary refrigerant vapor and the high pressure primary refrigerant cools and liquefies the high pressure refrigerant. The liquid high pressure primary refrigerant is then vaporized and expanded at the cooling tip of a cryosurgical catheter to provide the cooling power necessary for effective ablation of tissue. The method and apparatus of the present invention can be used equally well in a rigid hand held cryoprobe, or in a catheter.

The primary-to-secondary heat exchanger is part of the secondary refrigeration system, which can have a secondary compressor and a secondary expansion element, in addition to the primary-to-secondary heat exchanger. The liquid high pressure secondary refrigerant, having a higher critical temperature than the primary refrigerant, can be at a temperature which is relatively higher than the critical temperature of the primary refrigerant. However, the vaporized and expanded low pressure secondary refrigerant is at a temperature which is low enough to cool the primary refrigerant below its critical temperature. Since the secondary refrigerant has a critical temperature above normal operating room temperature, it can easily be provided in the liquid state in an operating room environment, whereas the primary

refrigerant, which has a critical temperature significantly below normal operating room temperature, can not.

The liquid high pressure primary refrigerant is conducted from the heat exchanger to the inlet of a primary Joule-Thomson expansion element located in the cold tip of the probe or catheter, where the primary refrigerant is vaporized and expanded to a lower pressure and a lower temperature.

The primary refrigerant exiting the primary Joule-Thomson expansion element is exposed to the inner surface of a heat transfer element at the cold tip. The vaporized and expanded primary refrigerant cools the heat transfer element to a lower temperature and then returns through the low pressure return passageway of the catheter or probe.

The novel features of this invention, as well as the invention itself, will be best understood from the attached drawings, taken along with the following description, in which similar reference characters refer to similar parts, and in which:

#### BRIEF DESCRIPTION OF THE SEVERAL VIEWS OF THE DRAWINGS

FIG. 1 is a schematic view of the preferred embodiment of the apparatus of the present invention; and

FIG. 2 is a schematic section view of the primary-to-secondary heat exchanger used in the apparatus shown in FIG. 1.

#### DETAILED DESCRIPTION OF THE INVENTION

The present invention lies in the appropriate use of a secondary evaporative refrigeration system to precool and liquefy the primary high pressure refrigerant, before passage of the primary refrigerant through a primary Joule-Thomson expansion element. This is intended to enable the generation of a sufficiently low temperature, and to maximize the available cooling power, at the cold tip of a cryosurgical probe or catheter.

Pre-cooling the primary refrigerant to an at least partially liquid state, prior to feeding it to the primary expansion element, is the focus of the present invention. This pre-cooling can be done prior to introducing the primary refrigerant into the catheter, by the use of a heat exchanger in a cooling console. Alternatively, pre-cooling can be provided nearer to the treatment area, such as in the handle of a cryoprobe, or at the proximal end of a catheter.

An important parameter in the design of a cryosurgical device is the cooling power which the refrigeration system can develop. The cooling power determines the rate of cooling in degrees per accord, and the temperature which can be maintained at the probe tip during freezing of the tissue. The rate of freezing is important in achieving cell death, since more rapid freezing results in better formation of intracellular ice crystals, resulting in cell lysis. The rate of freezing also determines the length of time required to perform a given procedure on the patient. The quicker the procedure, the less traumatic the procedure is to the patient.

The temperature which can be maintained at the probe cold tip determines the size of the ice ball formed in the surrounding tissue. This, of course, determines the total volume of tissue destroyed at each location, and the speed with which the procedure can be completed.

In Joule-Thomson cryosurgical devices, high pressure fluid expands across a restriction of some kind, such as a small orifice, or a restricted tube. The sudden drop in pressure results in a corresponding drop in temperature. The

cooling power of the device is the product of the mass flow rate of the cryogen and the enthalpy difference at the different pressures and temperatures. The flow rate is a function of orifice size and the temperature and pressure of the cryogen. For a given orifice size, under non-choking conditions, the density of the cryogen is higher at higher pressures and lower temperatures, resulting in a higher mass flow rate. The maximum flow rate is found at the point where the cryogen is a liquid. The enthalpy difference is also a function of the pressure and temperature. For a given temperature and a given pressure, the maximum enthalpy difference between two conditions occurs at the liquefaction point of the cryogen. Incorporating a pre-cooling heat exchanger into the refrigeration system, to promote liquefaction of the high pressure primary cryogen, increases the power of the system.

If the primary refrigerant is in the gaseous state upon startup of the refrigeration system, the early flow rate is very low, and the power is very low. Therefore, the initial cool down is very slow at overcoming the low flow rate. Further, the cold tip is typically placed within the patient, and in contact with the target tissue, before commencement of cooldown, placing a significant heat load on the tip. This means that cooldown can be unacceptably slow, and in some cases, it may not occur at all.

In order to maximize the performance of the present cryosurgical system, and to eliminate the problems normally associated with slow cooldown rates and low cooling power, an independent secondary evaporative refrigeration system is incorporated. The primary system uses a refrigerant such as freon, or SUVA-95, to achieve the desired temperature and capacity at the cold tip. However, the critical temperature of such a refrigerant is below the temperature normally found in the operating room environment, so provision of the primary refrigerant in the liquid state requires precooling. The secondary system uses a refrigerant such as AZ-20, to pre-cool and liquefy the primary refrigerant prior to flow of the primary refrigerant to the cold tip. The secondary system accomplishes this pre-cooling through a primary-to-secondary heat exchanger. This pre-cooling causes the initial flow rate and the cooling power of the system to be higher, making the initial cooldown rate much faster.

As shown in FIG. 1, the apparatus 10 of the present invention includes a source of gaseous high pressure primary refrigerant 12, a source of liquid high pressure secondary refrigerant 14, a primary-to-secondary heat exchange unit 16, and a probe or catheter 18 with a cold tip 20. The gaseous primary refrigerant source 12 can incorporate a pressure bottle as schematically shown, with the primary loop being an open loop, or the source 12 can incorporate a compressor, with the primary loop being a closed loop, as will be explained below. The primary refrigerant is one which, in order to deliver the desired temperature and cooling capacity at the cold tip 20, necessarily has a critical temperature below the temperature of the operating room environment. The purpose of the present invention is to cool that gaseous primary refrigerant below its critical temperature and convert it to a liquid refrigerant, in order to achieve the desired temperature and cooling capacity. A flexible coaxial catheter 18 can be constructed with an outer tube made of pebax, and an inner tube made of polyimide.

Gaseous high pressure primary refrigerant flows from the primary refrigerant source 12 via a conduit 32 into the heat exchange unit 16. After heat exchange and liquefaction, liquid primary refrigerant, at a temperature below the temperature of the operating room environment, flows from the heat exchange unit 16 into the catheter or probe 18. Near the

5

distal tip of the catheter **18**, the liquid primary refrigerant is vaporized and expanded at an expansion element shown schematically as an orifice **36**. This lowers the temperature of the primary refrigerant to the desired temperature, enabling the refrigerant to cool the cold tip **20** to the selected temperature for tissue ablation. Gaseous primary refrigerant returning from the cold tip **20** exits the heat exchange unit **16** via a conduit **34**. Where the primary refrigerant source **12** incorporates a pressure bottle, the primary loop can be operated as an open loop, and the gaseous primary refrigerant conduit **34** can be collected by a compressor **22** to vent to atmosphere or to a collector **24**. Alternatively, the primary loop can be operated as a closed loop, and the gaseous primary refrigerant conduit **32** can be routed (not shown) from the outlet of the compressor **22**, as is well known in the art.

The liquid secondary refrigerant source **14** can incorporate a compressor unit as schematically shown, or it can incorporate a pressure bottle. If required to generate the necessary pressure for liquefaction of the secondary refrigerant, a compressor can be used to raise the pressure of the effluent from a pressure bottle. The secondary refrigerant source **14** can also include a condenser, as is well known in the art, for liquefying the secondary refrigerant, if required. The secondary refrigerant must be one which has a critical temperature above the temperature of the operating room environment, so that the secondary refrigerant can be conducted in liquid form to the primary-to-secondary heat exchange unit **16**. This enables the use of the phase-change enthalpy difference in the secondary refrigerant to provide the necessary cooling to take the primary refrigerant below its critical temperature to the heat exchange unit **16**.

Liquid high pressure secondary refrigerant, at a temperature above the temperature of the operating room environment, flows from the secondary refrigerant source **14** via a conduit **28** into the heat exchange unit **16**. After vaporization and heat exchange, gaseous secondary refrigerant flows from the heat exchange unit **16** via a conduit **30**. Where the secondary refrigerant source **14** incorporates a pressure bottle, the secondary loop can be operated as an open loop, and the gaseous secondary refrigerant conduit **30** can vent to atmosphere or in a collector (not shown) as is well known in the art. Alternatively, the secondary loop can be operated as a closed loop, and the gaseous secondary refrigerant conduit **30** can be routed to the inlet of a compressor in the secondary refrigerant source **14**, as shown.

As shown schematically in FIG. **2**, liquid high pressure secondary refrigerant enters the heat exchange unit **16** via a supply conduit **28** and is vaporized and expanded via a secondary expansion element shown as a capillary tube **29**. The vaporized and expanded secondary refrigerant, at a temperature below the critical temperature of the primary refrigerant, then flows through a secondary refrigerant flow path in a primary-to-secondary heat exchanger **26** and exits the heat exchange unit **16** via a return conduit **30**.

Gaseous high pressure primary refrigerant enters the heat exchange unit **16** via a supply conduit **32** and flows through a primary refrigerant flow path in the heat exchanger **26**. Since the temperature of the secondary refrigerant flowing through the heat exchanger **26** is significantly below the critical temperature of the primary refrigerant, the primary refrigerant is liquefied in the heat exchanger **26**. Liquid primary refrigerant then exits the heat exchanger via a conduit **33** and flows through the catheter **18** to a primary expansion element, shown schematically as an orifice **36**, near the cold tip **20**. The primary expansion element **36** vaporizes and expands the primary refrigerant to the selected temperature for cooling the cold tip **20** to the desired

6

temperature for ablation of tissue. The vaporized and expanded primary refrigerant returning from the cold tip **20** then flows back through the catheter **18**, through the heat exchange unit **16**, and exits the heat exchange unit **16** via a return conduit **34**.

While the particular invention as herein shown and disclosed in detail is fully capable of obtaining the objects and providing the advantages hereinbefore stated, it is to be understood that this disclosure is merely illustrative of the presently preferred embodiments of the invention and that no limitations are intended other than as described in the appended claims.

I claim:

1. A cryosurgical instrument for ablation of endocardiac tissue, comprising:

a source of a gaseous primary refrigerant said source providing said primary refrigerant at a temperature above the critical temperature of said primary refrigerant;

a source of a liquid secondary refrigerant, said secondary refrigerant having a critical temperature higher than said critical temperature of said primary refrigerant;

a secondary expansion element connected to receive said liquid secondary refrigerant, said secondary expansion element being constructed to vaporize and expand said secondary refrigerant to a temperature below said critical temperature of said primary refrigerant;

a primary-to-secondary heat exchanger having a primary refrigerant flow path connected to receive said gaseous primary refrigerant, and a secondary refrigerant flow path connected to receive said vaporized and expanded secondary refrigerant from said secondary expansion element, said heat exchanger being constructed to cool and liquefy said primary refrigerant;

a primary expansion element connected to receive said liquid primary refrigerant from said heat exchanger, said primary expansion element being constructed to vaporize and expand said primary refrigerant to a selected cryogenic temperature; and

a cryoablation heat transfer element connected to receive said vaporized and expanded primary refrigerant; wherein said primary refrigerant comprises SUVA-95, and said secondary refrigerant comprises AZ-20.

2. A cryosurgical instrument for ablation of cardiac tissue, comprising:

a source of a gaseous primary refrigerant, wherein said primary refrigerant is a single gas and has a critical temperature;

a source of a liquid secondary refrigerant, said secondary refrigerant having a critical temperature higher than said critical temperature of said primary refrigerant;

a secondary expansion element connected to receive said liquid second refrigerant, said secondary expansion element being constructed to vaporize and expand said secondary refrigerant to a temperature below said critical temperature of said primary refrigerant;

a primary-to-secondary heat exchanger having a primary refrigerant flow path connected to receive said gaseous primary refrigerant, and a secondary refrigerant flow path connected to receive said vaporized and expanded secondary refrigerant from said secondary expansion element, said heat exchanger being constructed to cool and liquefy said primary refrigerant;

a primary expansion element connected to receive said liquid primary refrigerant from said heat exchanger, said primary expansion element being constructed to

7

*vaporize and expand said primary refrigerant to a selected cryogenic temperature; and*

*a cryoablation heat transfer element connected to receive said vaporized and expanded primary refrigerant.*

3. *A cryosurgical instrument as recited in claim 2 further comprising:* 5

*a first conduit connecting said primary-to-secondary heat exchanger in fluid communication with said primary expansion element for flowing said liquid primary*

8

*refrigerant from said heat exchanger to said primary expansion element; and*

*a second conduit juxtaposed with said first conduit for back flowing said primary refrigerant from said primary expansion element for exit through said primary-to-secondary heat exchanger.*

\* \* \* \* \*