



US00RE40036E

(19) **United States**
 (12) **Reissued Patent**
Satoh et al.

(10) **Patent Number: US RE40,036 E**
 (45) **Date of Reissued Patent: Jan. 29, 2008**

(54) **SURFACE ACOUSTIC WAVE FILTER**
 (75) Inventors: **Yoshio Satoh**, Kawasaki (JP); **Osamu Ikata**, Kawasaki (JP); **Tsutomu Miyashita**, Kawasaki (JP); **Takashi Matsuda**, Kawasaki (JP); **Mitsuo Takamatsu**, Kawasaki (JP)

3,222,622 A * 12/1965 Curran et al. 333/192
 3,582,540 A 6/1971 Adler et al. 348/507
 4,044,321 A 8/1977 Vasile 333/194
 4,166,258 A 8/1979 Tseng 333/195

(Continued)

FOREIGN PATENT DOCUMENTS

(73) Assignee: **Fujitsu Limited**, Kawasaki (JP)

DE 3323612 1/1984
 EP 0337703 10/1989
 EP 0353073 1/1990
 EP 0 401 737 A2 12/1990
 EP 0 422 637 A2 4/1991

(21) Appl. No.: **09/925,942**

(22) Filed: **Aug. 10, 2001**

(Continued)

Related U.S. Patent Documents

Reissue of:

(64) Patent No.: **5,631,612**
 Issued: **May 20, 1997**
 Appl. No.: **08/369,492**
 Filed: **Jan. 6, 1995**

U.S. Applications:

(63) Continuation of application No. 09/314,943, filed on May 20, 1999, now Pat. No. Re. 37,390, which is a continuation of application No. 07/965,774, filed on Oct. 23, 1992, now Pat. No. 5,559,481.

(30) Foreign Application Priority Data

Oct. 28, 1991 (JP) 3-281694
 Feb. 19, 1992 (JP) 4-032270

(51) Int. Cl.

H03H 9/00 (2006.01)
H03H 9/64 (2006.01)
H03H 9/72 (2006.01)

(52) **U.S. Cl.** **333/193**; 333/133; 310/313 R

(58) **Field of Classification Search** 333/193-196,
 333/133; 310/313 R, 313 B, 313 C, 313 D
 See application file for complete search history.

(56) References Cited

U.S. PATENT DOCUMENTS

3,209,178 A * 9/1965 Koneval 310/355

OTHER PUBLICATIONS

U.S. Appl. No. 09/158,074, filed Sep. 22, 1998, Yoshio Satoh, et. al., Fujitsu Limited.

U.S. Appl. No. 09/314,943, filed May 20, 1999, Yoshio Satoh, et. al., Fujitsu Limited.

Urabe, S. et al., "SAW Resonator Type Voltage Controlled Oscillator for PLL-FM Modulator," *The Transactions of the Institute of Electronics and Communication Engineers of Japan*, vol. J65-B, No. 2, Feb. 1982, pp. 177-184.

Patent Abstract of Japan, Vol. 15, No. 74 (E-1036), Feb. 21, 1991 and JP-A-02 295212 (Fujitsu), Dec. 6, 1990.

(Continued)

Primary Examiner—Barbara Summons

(74) Attorney, Agent, or Firm—Staas & Halsey LLP

(57)

ABSTRACT

A SAW filter includes a first SAW resonator having a pair of terminals and a predetermined resonance frequency (f_{rp}), the first SAW resonator being provided in a parallel arm of the SAW filter. A second SAW resonator has a pair of terminals and a predetermined resonance frequency (f_{rs}) approximately equal to a predetermined antiresonance frequency of the first SAW resonator (f_{ap}). The second SAW resonator is provided in a series arm of the SAW filter. An inductance element is connected in series to the first SAW resonator.

16 Claims, 75 Drawing Sheets

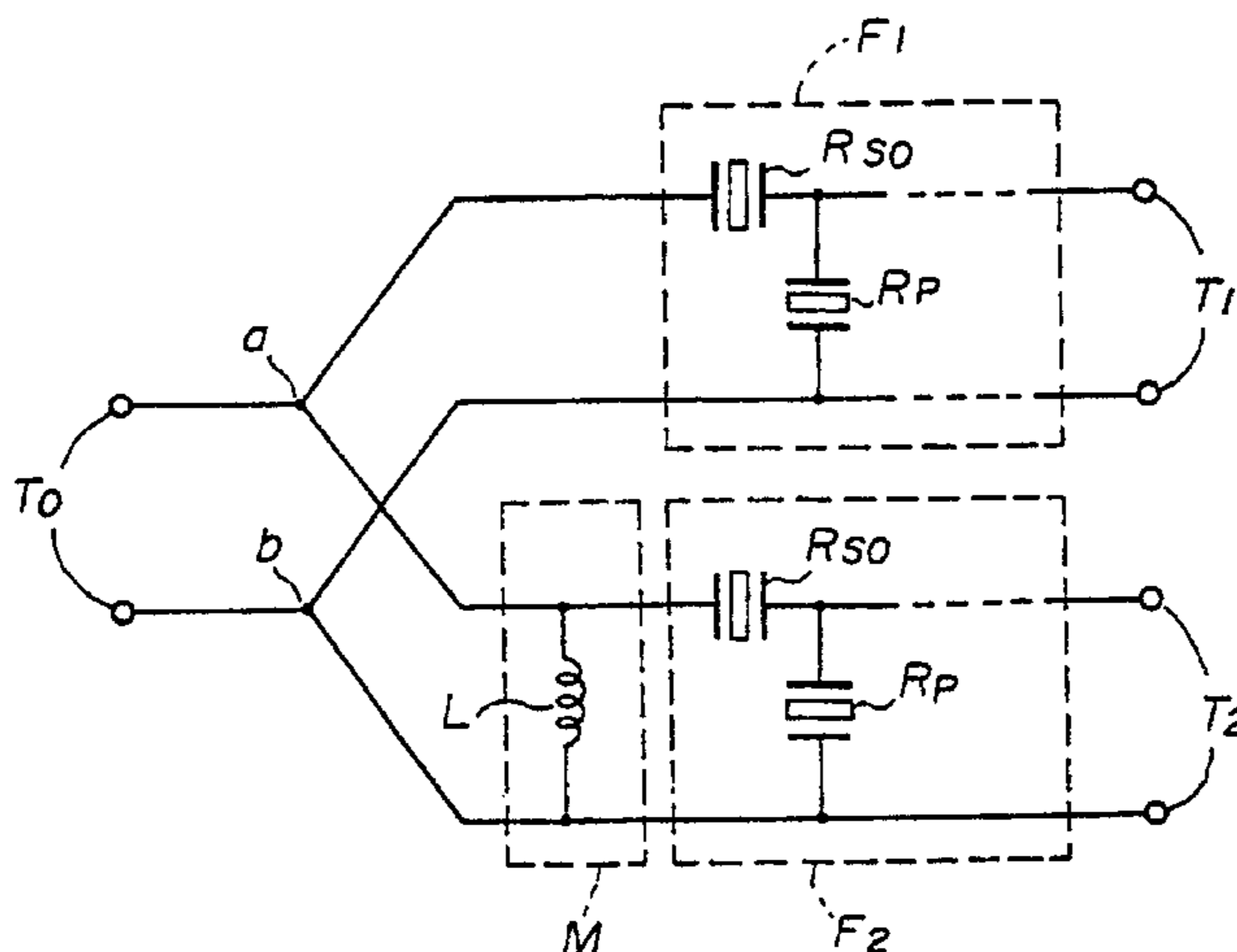

U.S. PATENT DOCUMENTS

4,295,108	A	10/1981	Ieki	333/193
4,320,365	A	* 3/1982	Black et al.	333/187
4,409,567	A	10/1983	Setsune et al.	333/151
4,494,031	A	1/1985	Barnes et al.	310/313 B
4,495,431	A	1/1985	Grudkowski	310/313 B
4,625,184	A	11/1986	Niitsuma et al.	333/150
4,684,841	A	8/1987	Este et al.	310/313 B
4,694,266	A	9/1987	Wright	333/196
4,734,664	A	3/1988	Hikita et al.	333/193
4,785,270	A	11/1988	Kinsman	333/193
RE32,859	E	2/1989	Marshall et al.	333/151
4,803,449	A	2/1989	Hikita et al.	333/193
4,939,487	A	7/1990	Yuhara et al.	333/193
4,954,793	A	9/1990	Misu et al.	333/133
4,978,879	A	12/1990	Satoh et al.	310/313 A
5,015,973	A	5/1991	Kawakami et al.	333/206
5,039,957	A	8/1991	Greer et al.	331/107 A
5,059,848	A	10/1991	Mariani	313/313 R
5,115,216	A	5/1992	Hikita et al.	333/195
5,162,822	A	* 11/1992	Wakamori	333/193
5,202,652	A	4/1993	Tabuchi et al.	333/193
5,231,327	A	* 7/1993	Ketcham	310/366
5,294,898	A	3/1994	Dworsky et al.	333/189
5,559,481	A	* 9/1996	Satoh et al.	333/193
RE37,375	E	* 9/2001	Satoh et al.	333/193

FOREIGN PATENT DOCUMENTS

FR	2283587	3/1976		
JP	56-165428	* 5/1955		
JP	3219044	* 2/1977		
JP	52-19044	2/1977		
JP	52-48452	4/1977		
JP	54-11120	6/1977		
JP	53-105156	9/1978		
JP	0069012	* 3/1980	333/133
JP	56-165428	5/1980		
JP	56-50613	5/1981		
JP	56-62416	5/1981		
JP	57-002105	1/1982		
JP	58-20002	2/1983		
JP	6081911	10/1983		
JP	59-158117	* 9/1984	333/194
JP	0081910	* 5/1985	333/133
JP	6081910	5/1985	333/133
JP	60-114010	6/1985		
JP	61-127220	6/1986		
JP	63-88910	4/1988		
JP	63-132515	6/1988		
JP	64-78511	3/1989		
JP	1-231417	9/1989		
JP	1-260911	10/1989		
JP	0290308	* 11/1989	333/193
JP	1-290308	11/1989	333/193
JP	2-58915	2/1990		
JP	2-69012	3/1990		
JP	416014	5/1990		
JP	3-220911	9/1991		
JP	3-297211	* 12/1991	333/193
JP	4016014	1/1992	333/133
JP	4-253412	9/1992	333/193
JP	4-253414	9/1992	333/133
JP	5167388	7/1993	333/133
JP	5-206778	8/1993		

OTHER PUBLICATIONS

The Transactions of the Institute of Electronics and Communication Engineers of Japan, Examination, Group 5, Telecommunication, vol. J65-B, No. 2, Feb. 1982, pp. 177-184 (137-280) Feb. 25, 1982, Tokyo.

Minature SAW Antenna Duplexer Used in 800-MHz Portable Telephone for Reverse Frequency Allocation Systems, M. Hikita, et al, Oct. 1989, pp. 31-38.

H. Satoh et al., "A Study of the Design of Acoustic Surface Wave Resonator for UHF Range VCO", National Convention Record, 1985, The Institute of Electronics and Communication Engineers of Japan, Part 1, Mar. 27-30, 1985, p. 1-97.

"Acoustic Surface Wave Resonators for Broadband Applications," J. Vandewege, et al, pp. 663-667, Proceeding of the 8th European Microwave Conference, 1978.

Attenuators, 9-5, Symmetrical T- and H-Attenuators, Electronic Engineering Databook, pp. 237-238 (1963).

Transmission Circuit Networks and Filters, pp. 78-81, 102-113, (1972).

Uniform Recurring Structure Propagation Constant, pp. 103-105, Wire Transmission Science, 1982.

"Distributed Constant Circuit", pp. 305-307, Basic Studies in Electronic, Telecommunications and Electrical Engineering, 1973.

Electronics Technology Series No. 7, New Piezoelectric Transducer-Resonator-Filter Technology 1996, 8th Edition, Editorial Staff, General Technology Publications, pp. 141-143.

Electric Circuit II, Tadashi Sekiguchi, Ph.D., Tokyo University, Published Nov. 10, 1977.

Handbook of Filter Synthesis, Zverev, 1967, pp. 425-427. "Active Development of SAW Resonator", *Nikkei Electronics*, Nov. 29, 1976, pp. 76 and 80.

"Theory and Design of Filters", *Sangyo-Shuppan*, pp. 192-203.

Y. Ebata et al, "SAW Resonator on LiTaO₃ Substrate and Application Thereof to Oscillator for VTR", *Journal of Institute of Electronics and Communication Engineers*, vol. J66-C, No. 1, Jan. 1983, pp. 23-30.

G. Kuraishi, "Microwave Circuits", *Tokyo Denki Daigaku Shuppan-Kyoku*, pp. 199.

O. Ikata et al, "Development of 800 MHz Band SAW Filters Using Weighting for the Number of Finger Pairs," *1990 Ultrasonics Symposium*, pp. 83-86.

K. Yamanouchi et al., "Applications for Piezoelectric Leaky Surface Waves," *1990 Ultrasonics Symposium*, pp. 11-13.

Patent Abstracts of Japan, vol. 15, No. 506 (E-1148) Dec. 20, 1991 and JP-A 3 220911 (Fujitsu) Sep. 30, 1991.

Yamanouchi et al., *Positive Negative Reflection-Type SAW Reflectors on St-Quartz Using New Fabrication Technique*; Japanese Journal of Applied Physics, Supplements; vol. 25, No. 1, 1985; pp. 154-156.

Yamanouchi et al., *5 Ghz Range SAW Filter Fabricated by Electron Beam Exposure with O-Plasma Ashing Techniques*; vol. 25, No. 1, 1985, pp. 154-156.

EP Search Report for related application No. EP 01 12 8369 dated Jun. 20, 2002.

EP Search Report for related application No. EP 01 12 8369 dated Jun. 20, 2002.

Tseng, "SAW Planar Network", IEEE Ultrasonics Symposium, IEEE, New York, NY, U.S. 1974, pp. 282-285, XP002064986.

J.E. Colin, "Ladder-Type Narrow Bandpass Filters, Using Piezoelectric Crystals and Having Low Frequency Composite Attenuation Poles", *Cables and Transmission*, vol. 16, No. 4, pp. 393-366, (Oct. 1962) (Original in French Language, English Language translation provided).

Crystal Filters, Second Quarterly Report, Motorola Inc., pp. 1-52 (Jul. 1, 1960 to Oct. 1, 1960).

Crystal Filters, Third Quarterly Report, Motorola Inc., pp. 1-56 (Oct. 1, 1960 to Jan. 1, 1961).

Crystal Filters, Sixth Quarterly Report, Motorola Inc., pp. 9-10, 29, 38, 51, 53, 55, 58, 60, 62 (Sep. 15, 1961 to Dec. 15, 1961) (excerpts only).

Crystal Filters, Seventh Quarterly Report, Motorola Inc., pp. 41, 42, 44, 45 (Dec. 15, 1961 to Mar. 15, 1962) (excerpts only).

Crystal Filters, Final Report, Motorola Inc., pp. 1-114 (Aug. 15, 1963).

Patent Abstracts of Japan, vol. 15, No. 506 (E-1148), Dec. 20, 1991 & JP-A-03 220911 (Fujitsu), Sep. 30, 1991.*

* cited by examiner

FIG. 1 PRIOR ART

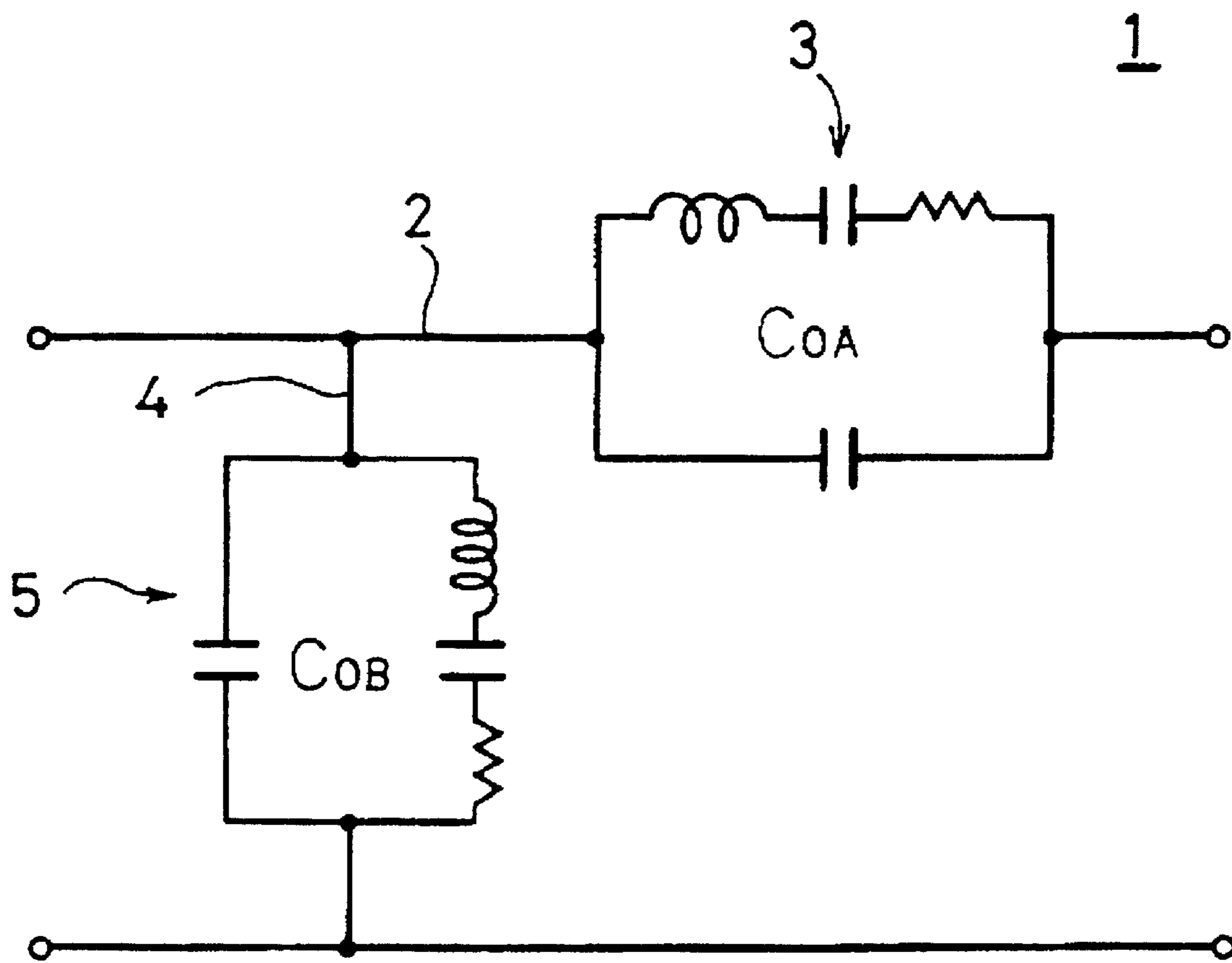

FIG. 2 PRIOR ART

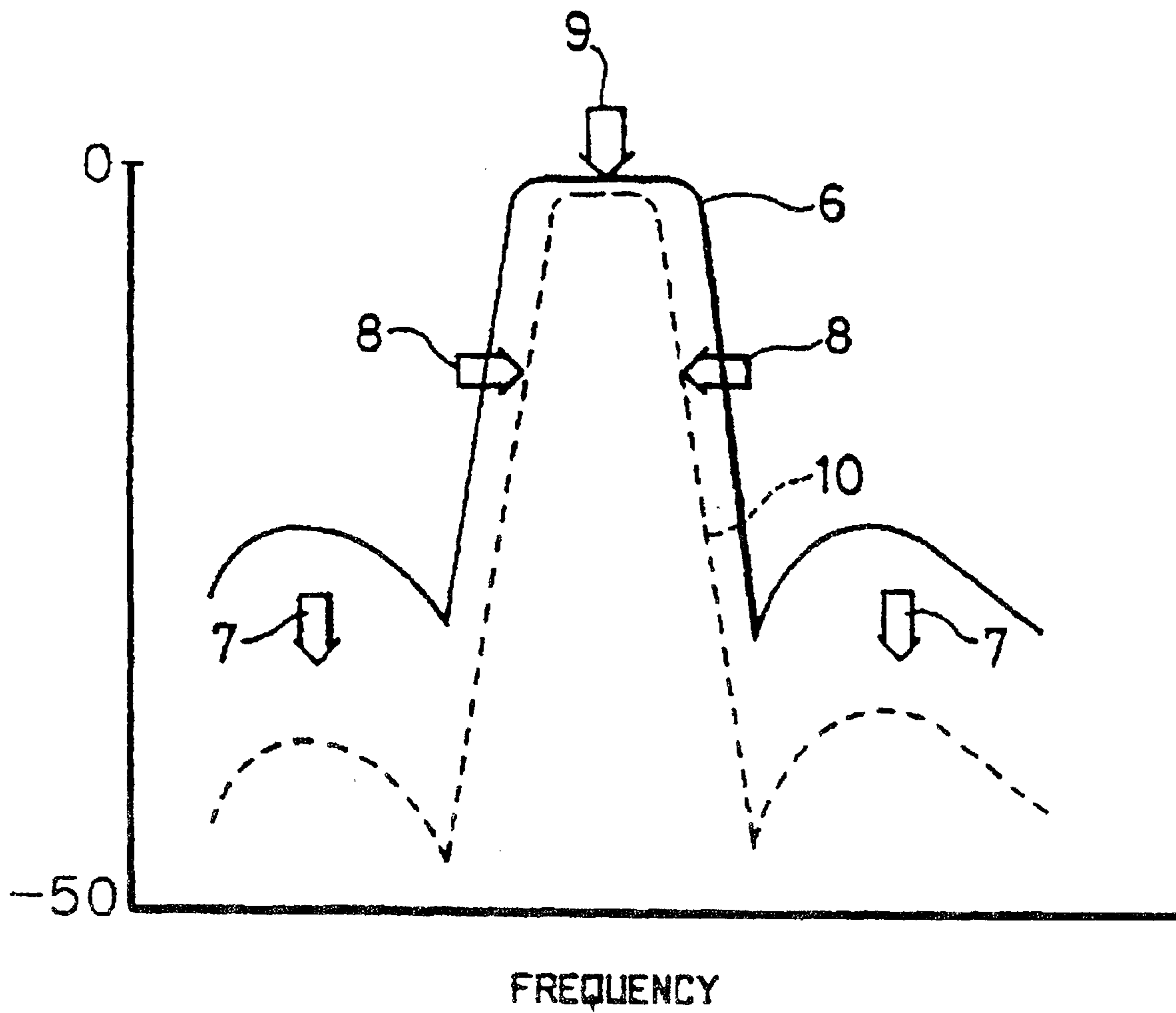

FIG. 3

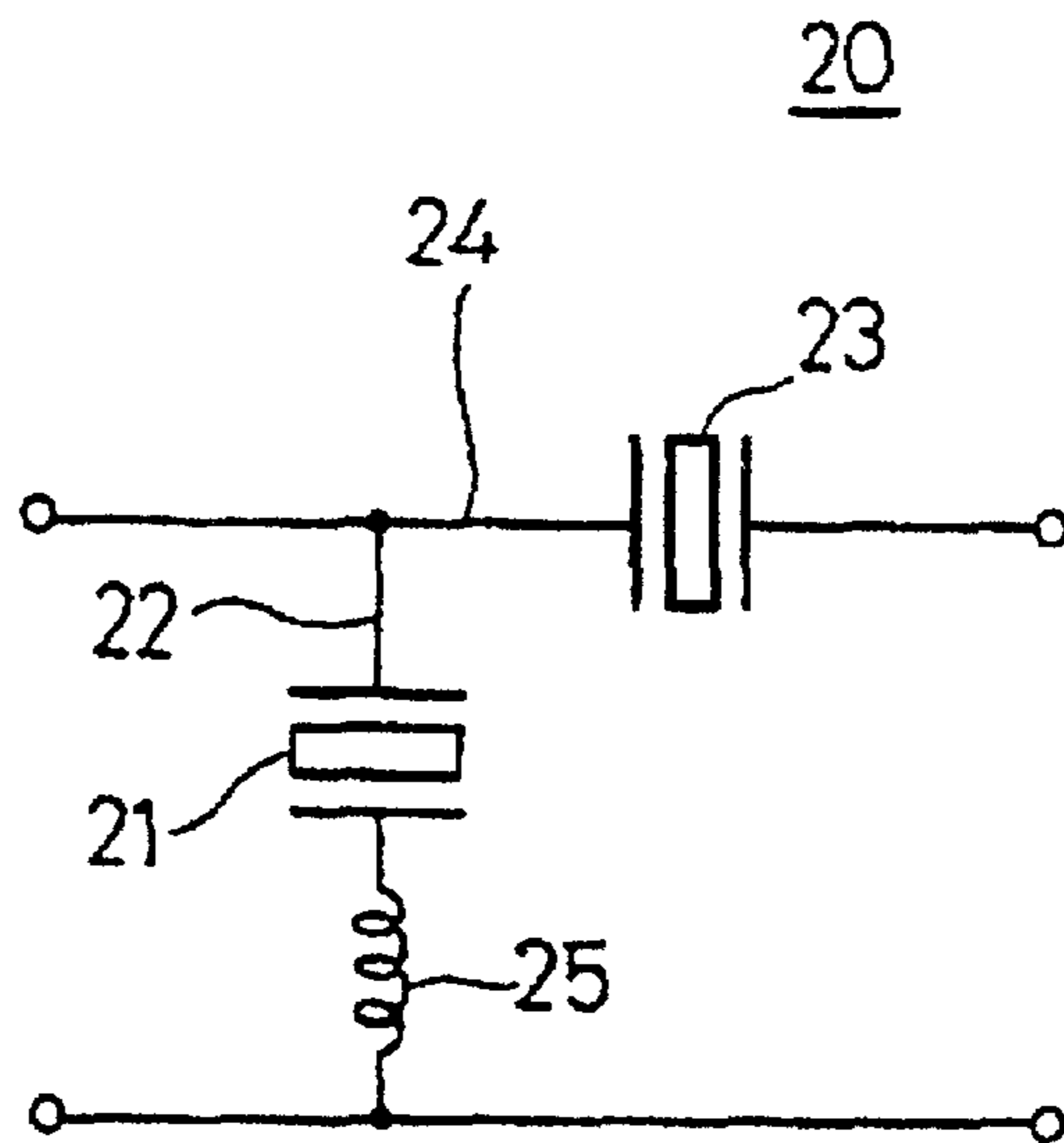
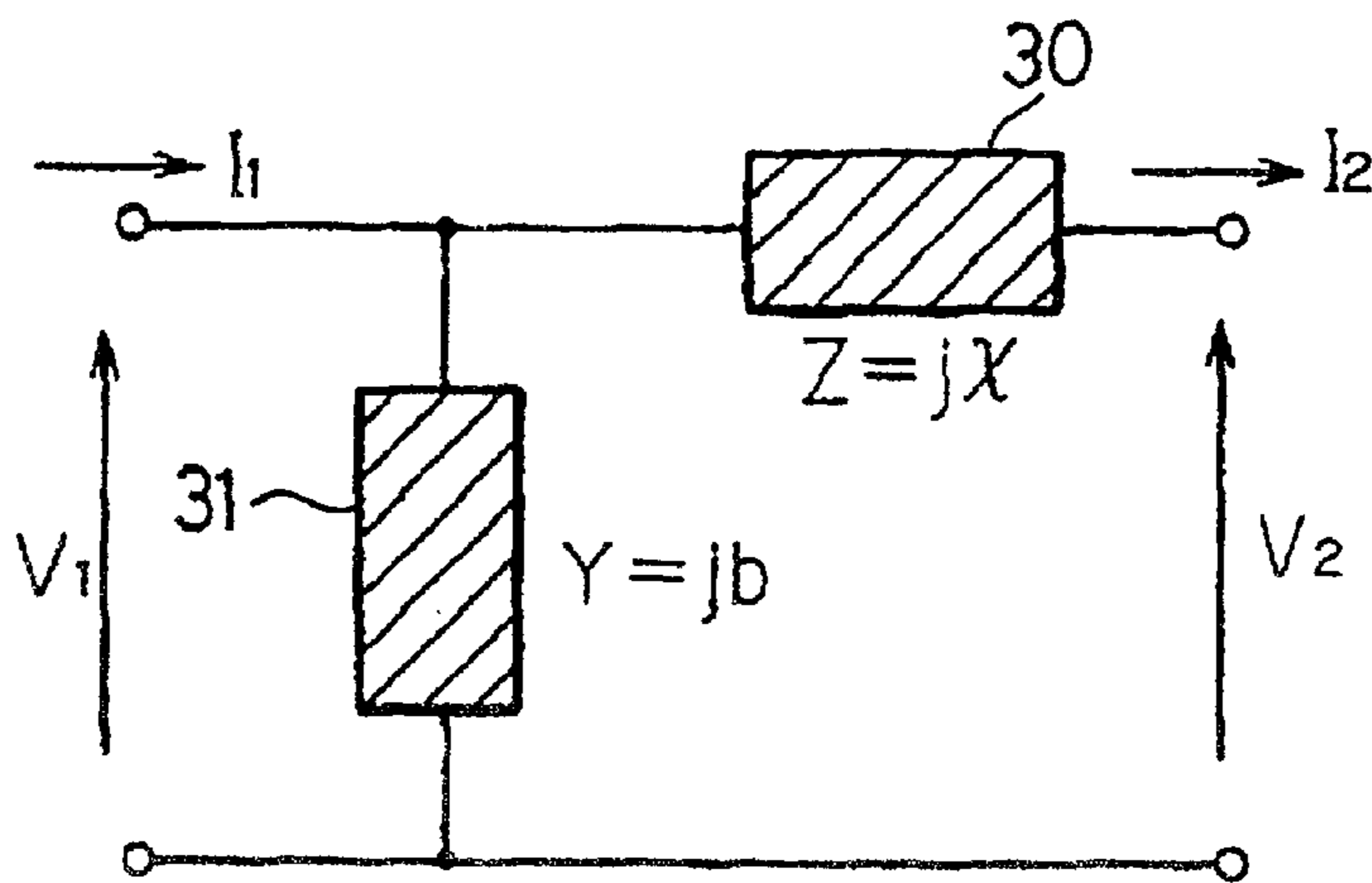

FIG. 4



F MATRIX

$$\begin{pmatrix} V_1 \\ I_1 \end{pmatrix} = \begin{pmatrix} A & B \\ C & D \end{pmatrix} \begin{pmatrix} V_2 \\ I_2 \end{pmatrix}$$

FIG. 5A

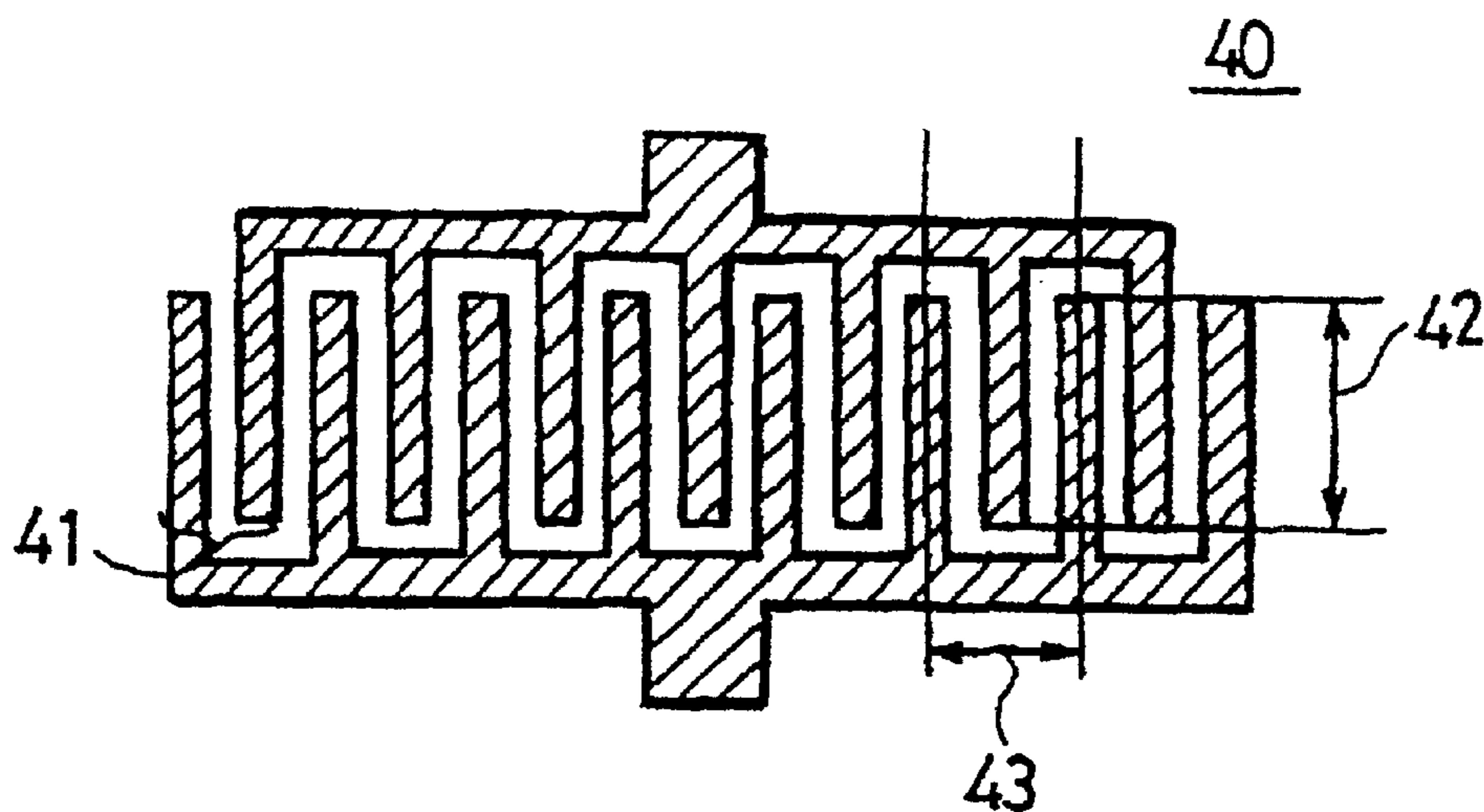

FIG. 5B

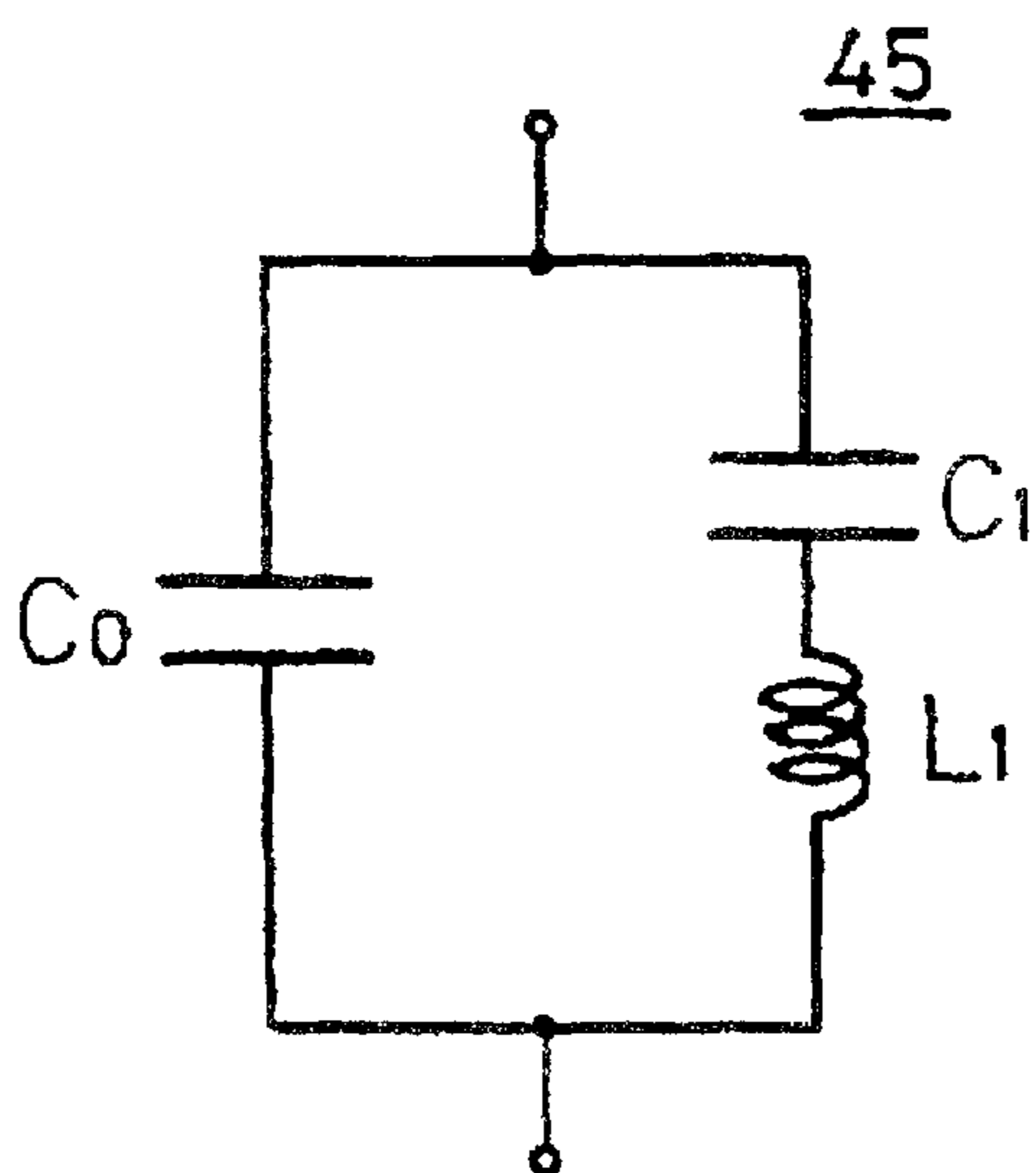

FIG. 5C

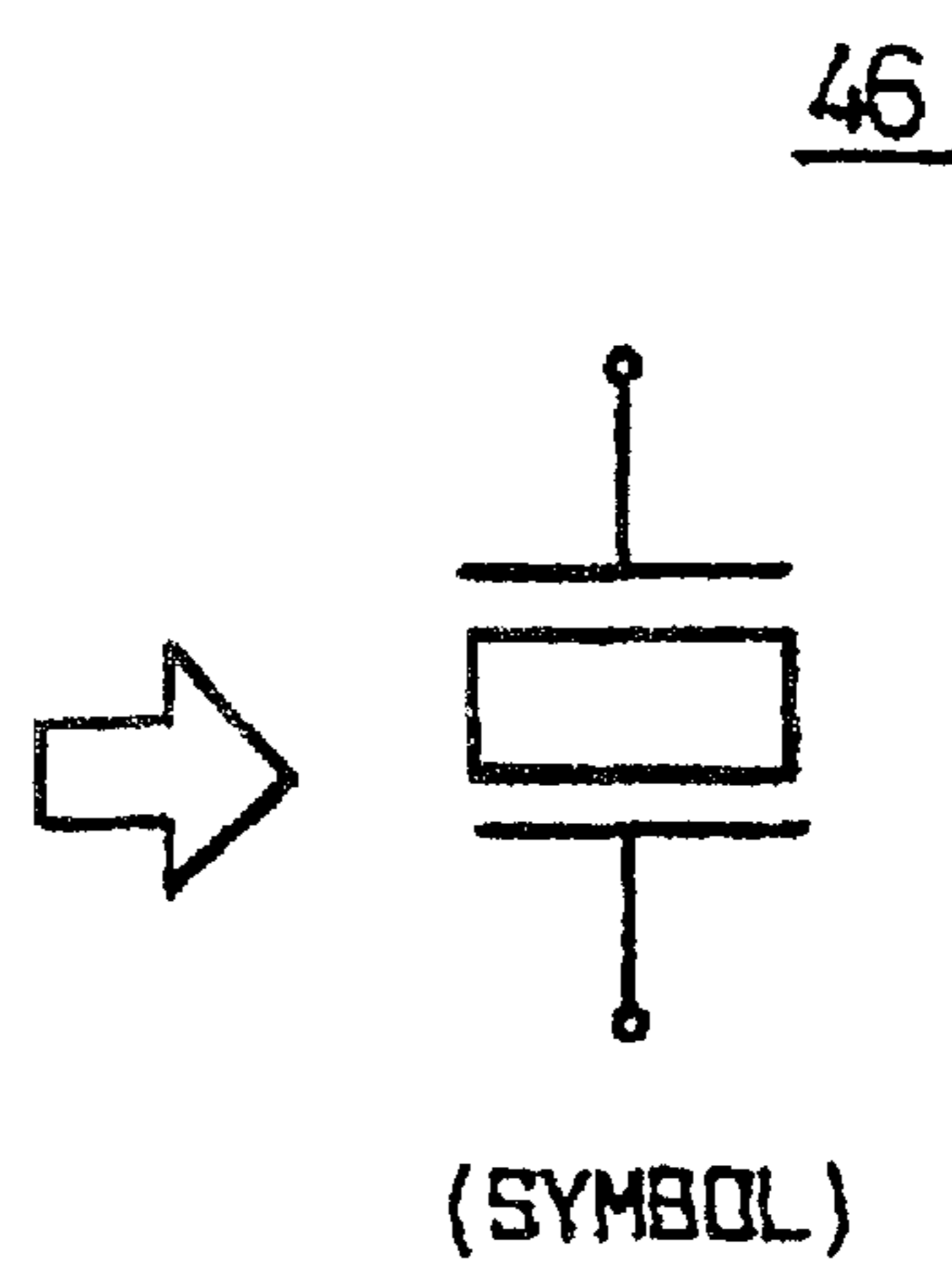

FIG. 6A

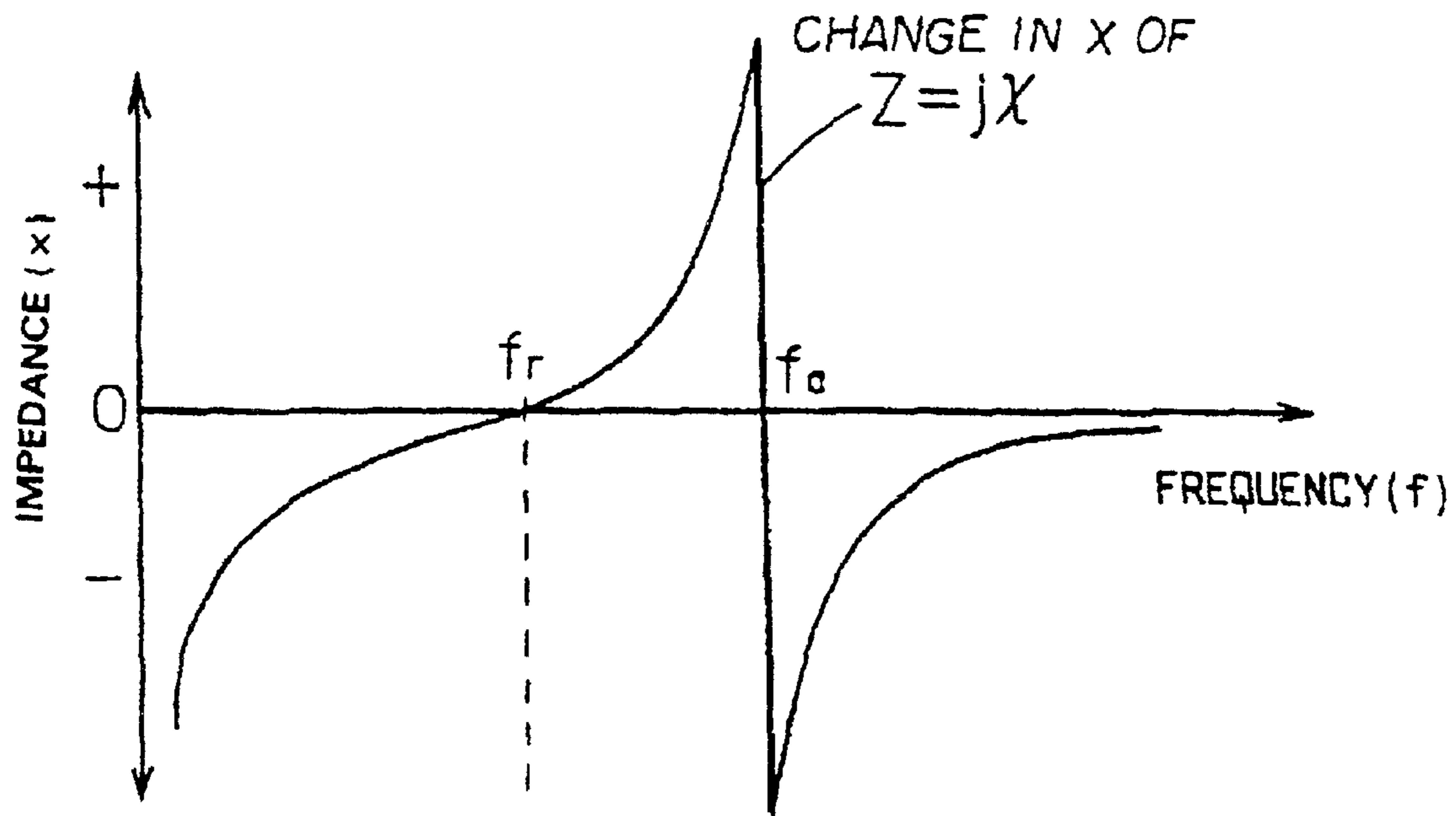
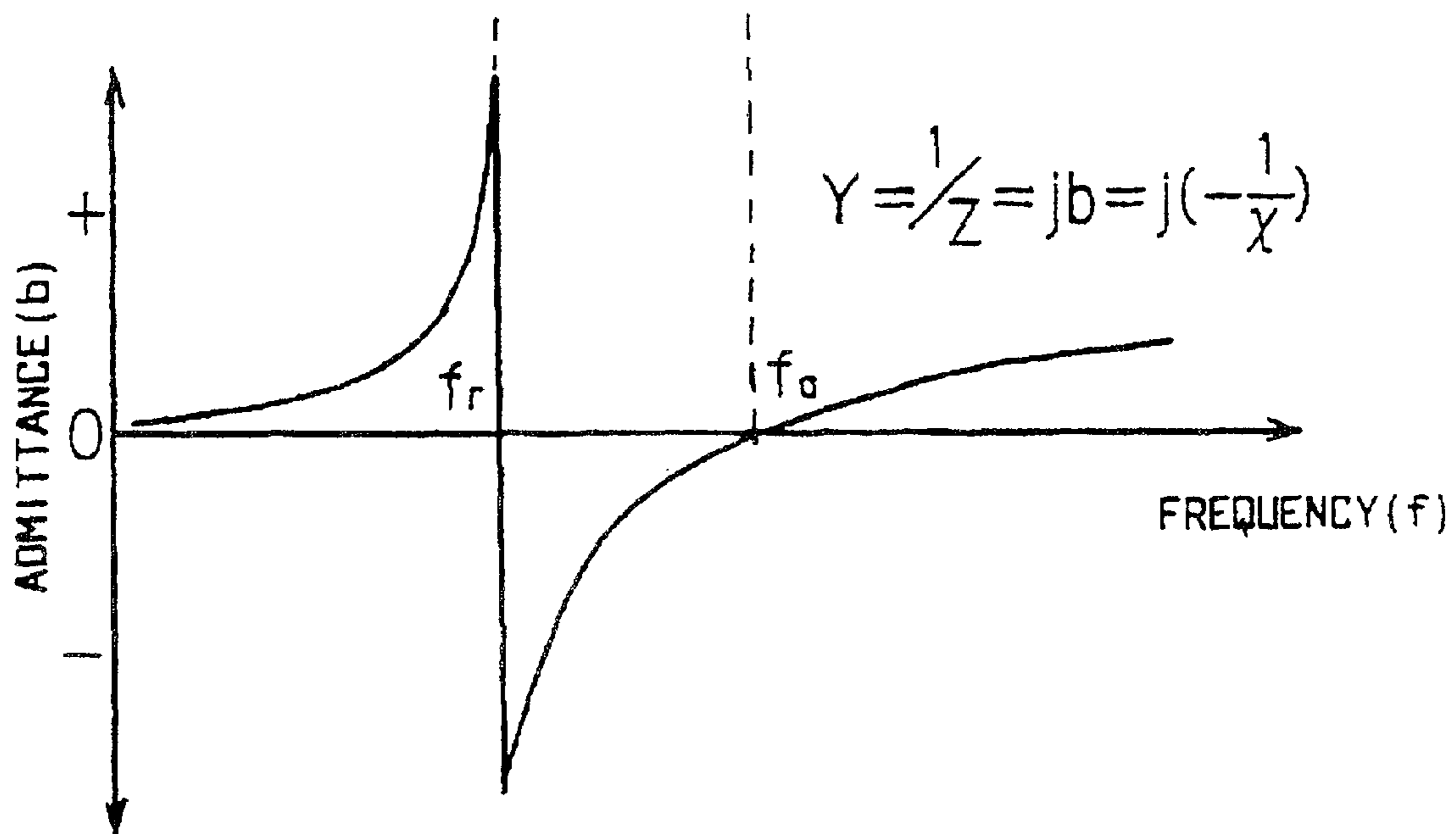
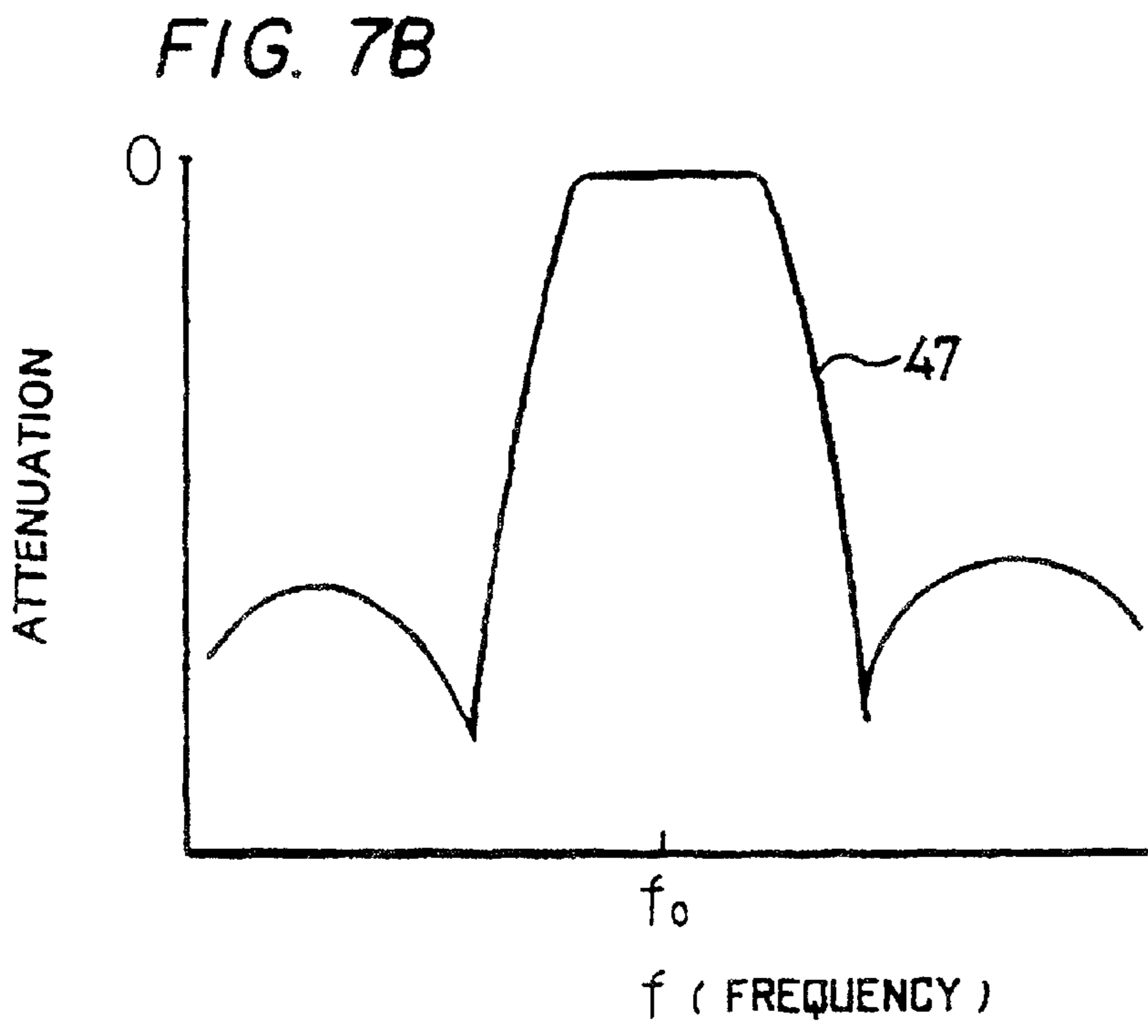
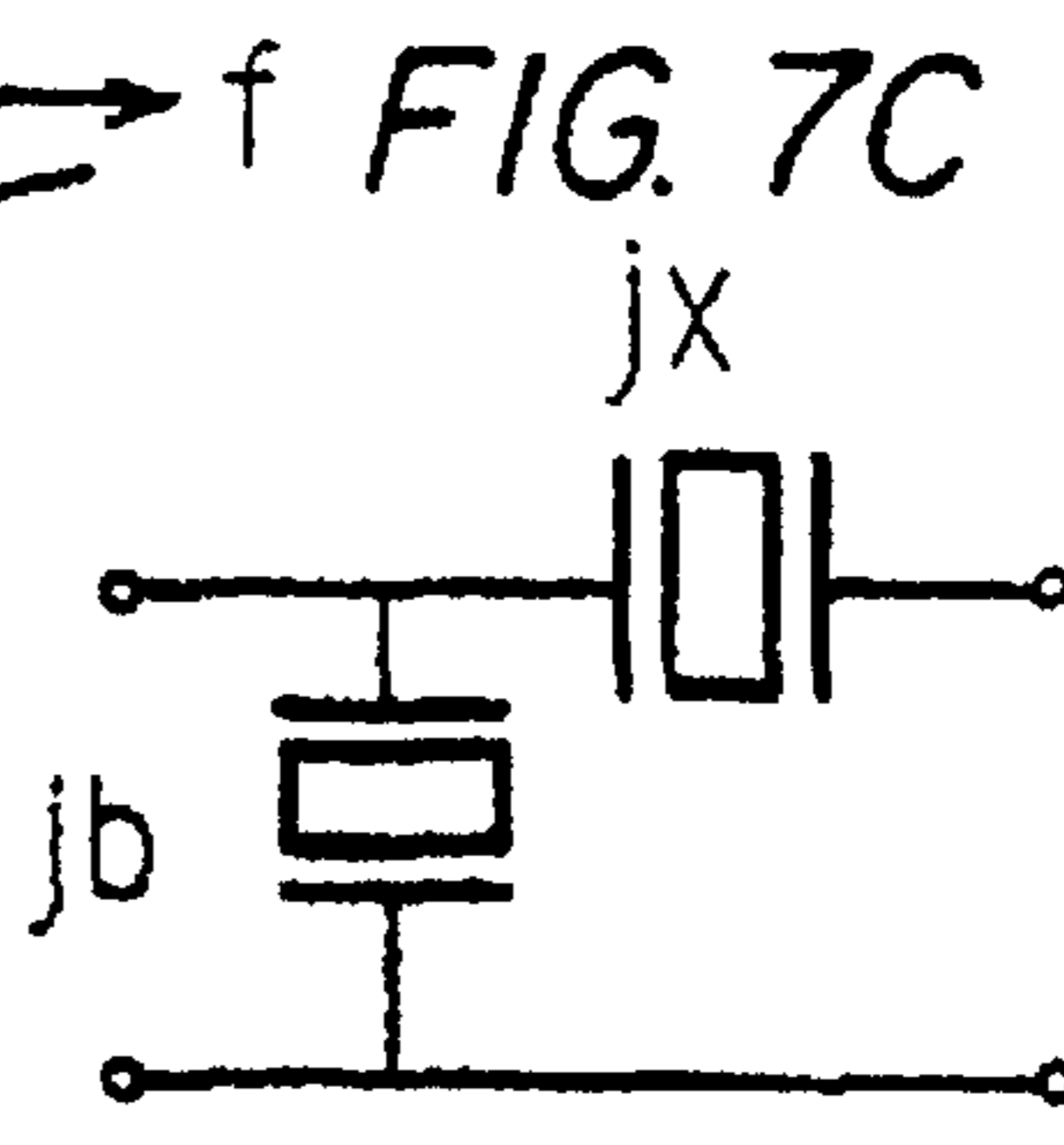
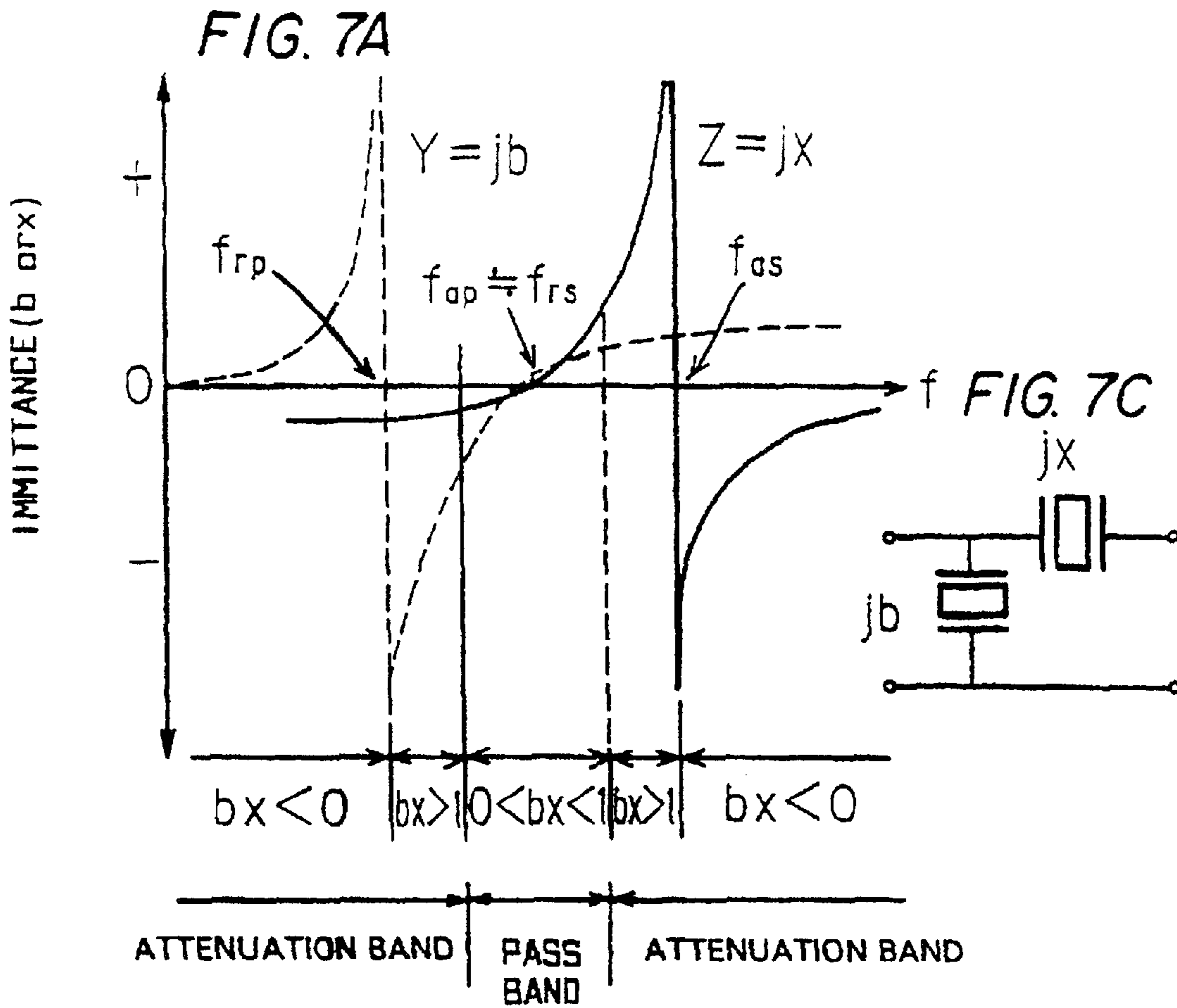

FIG. 6B





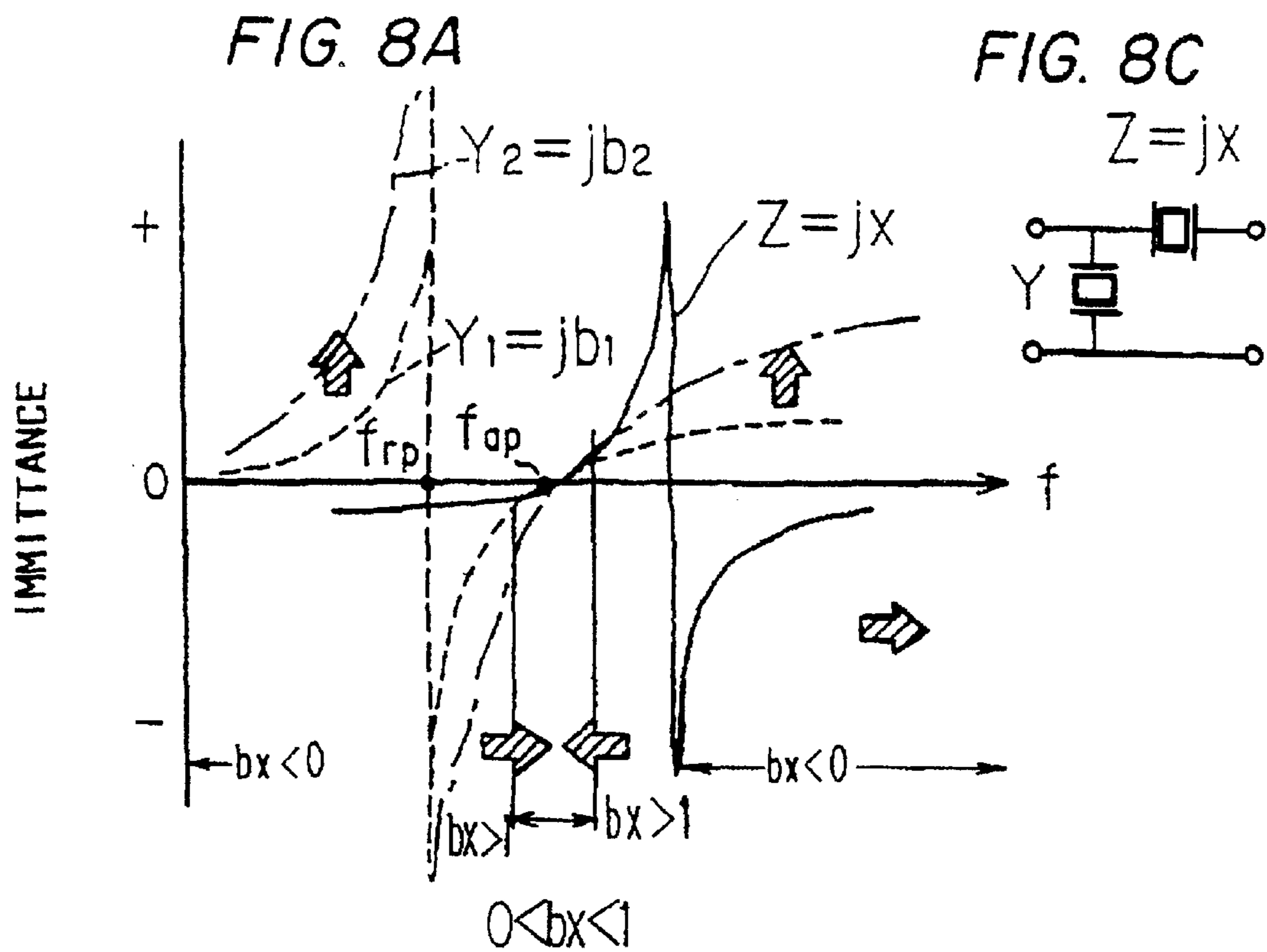

FIG. 8B

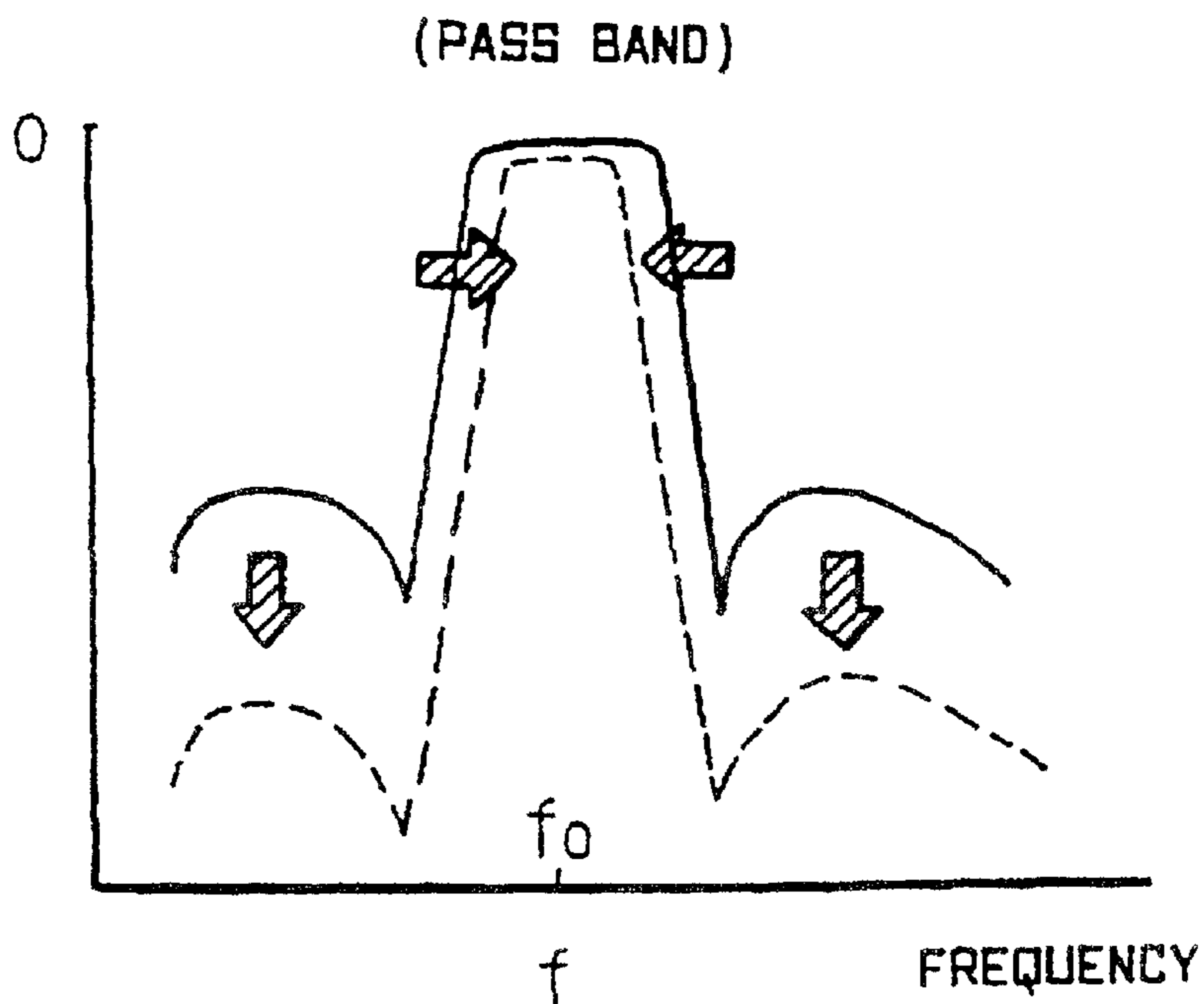

FIG. 9B

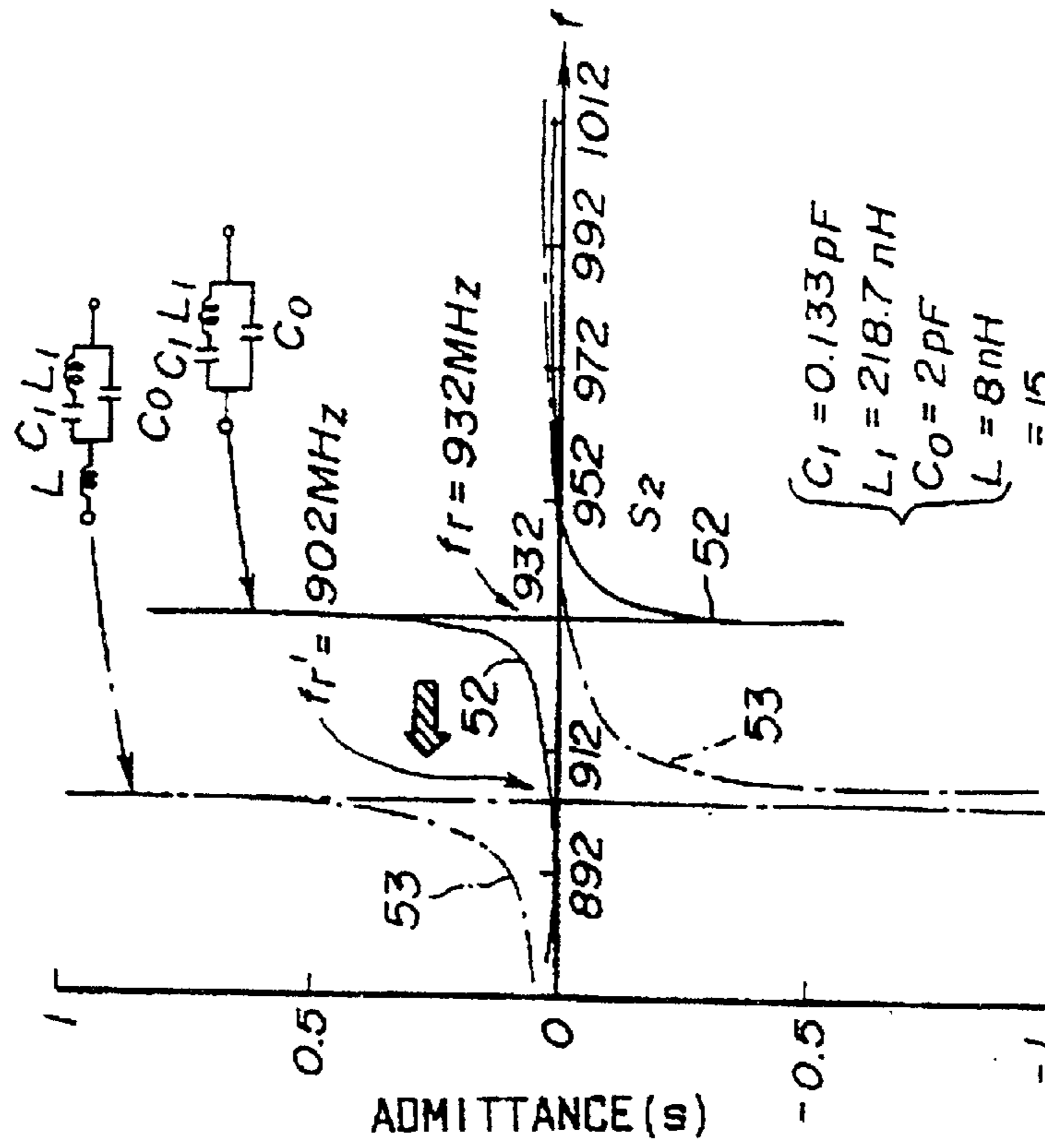

FIG. 9A

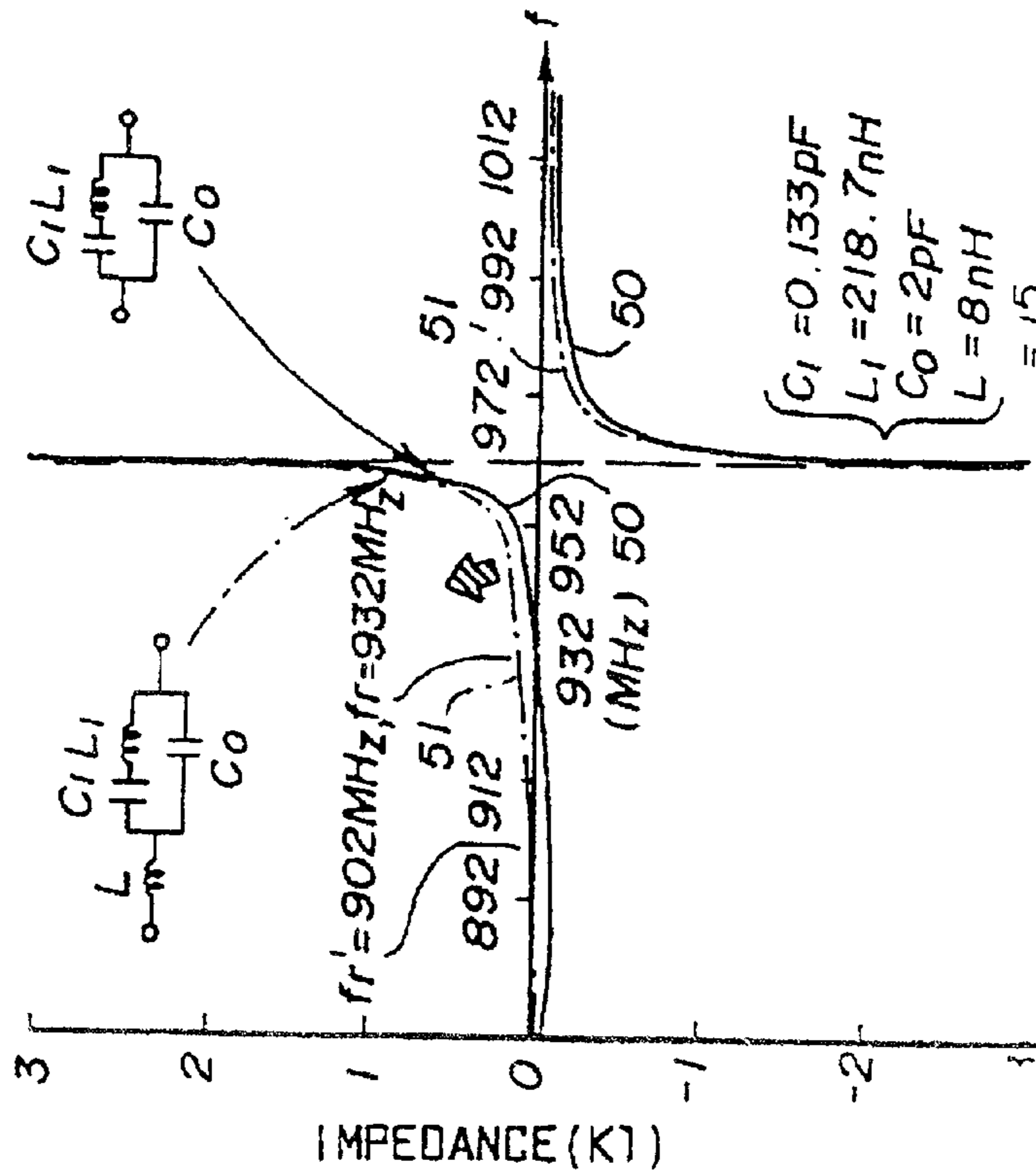

FIG. 10A

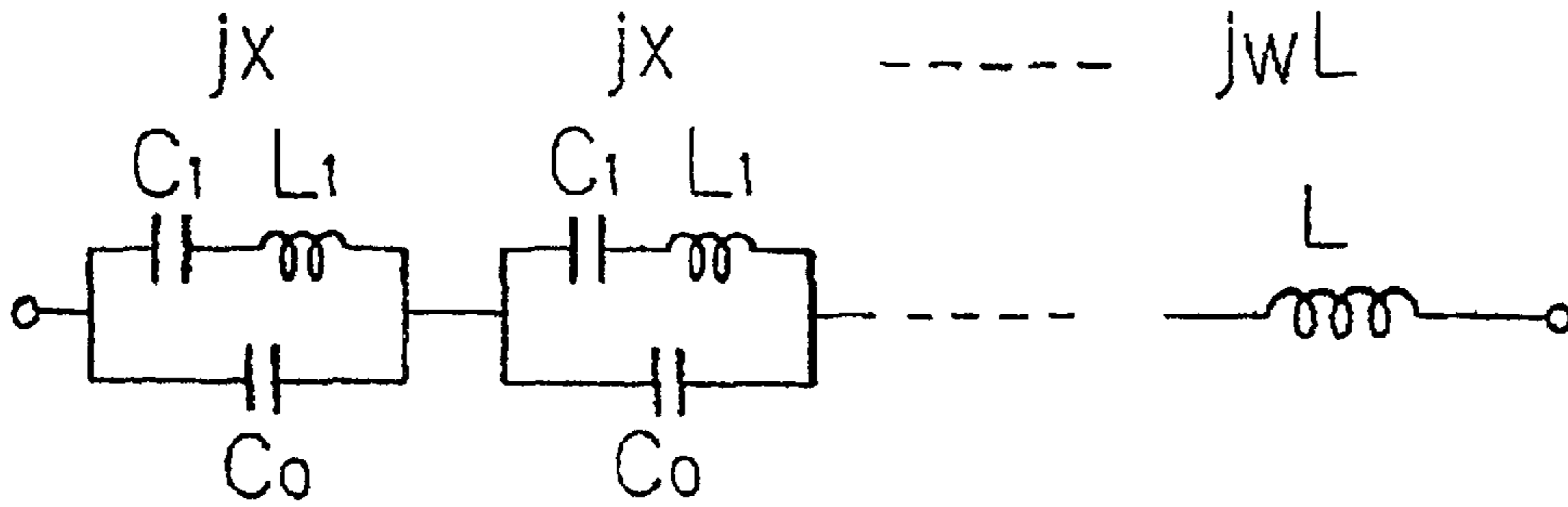

FIG. 10B

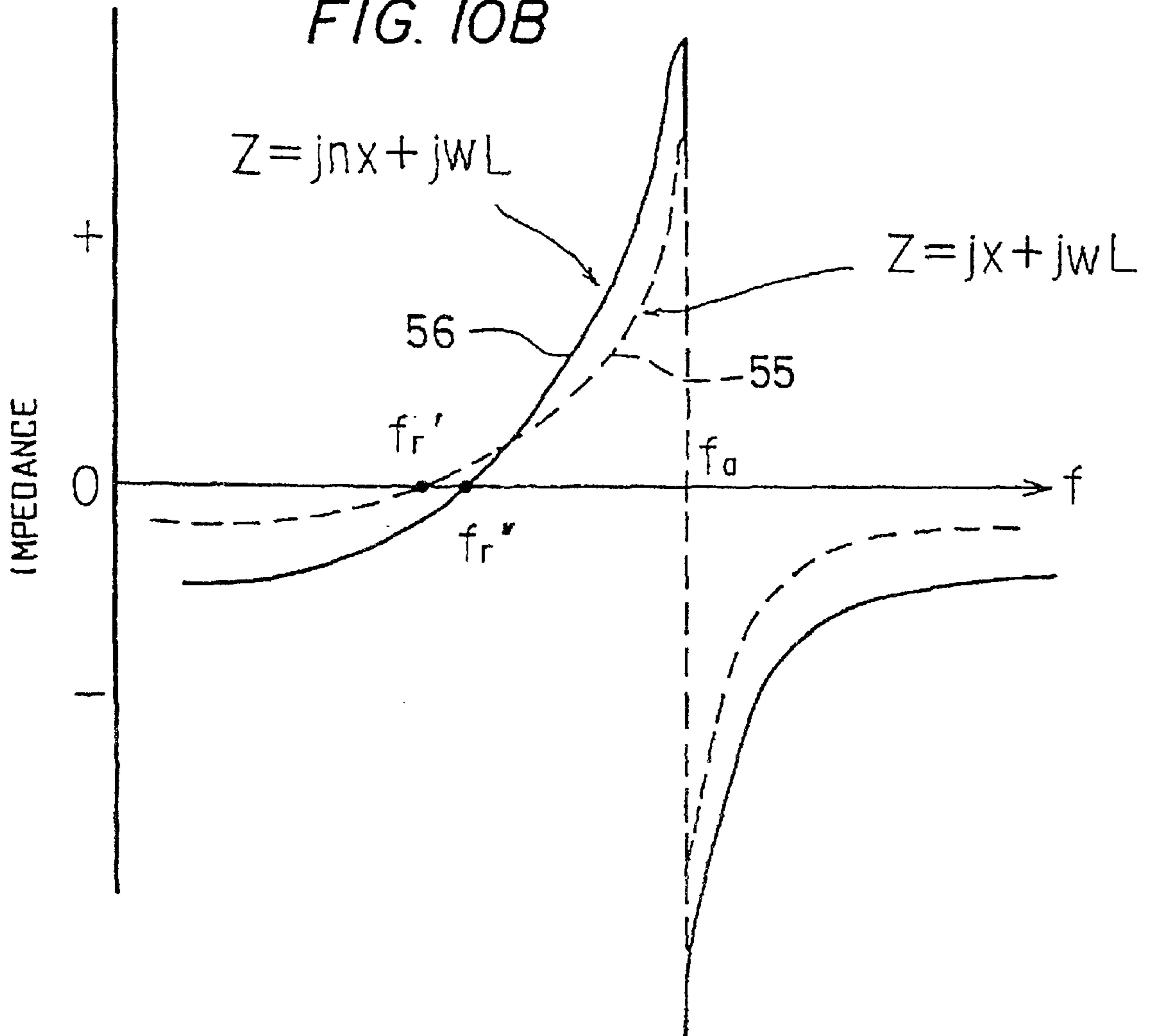

FIG. IIA

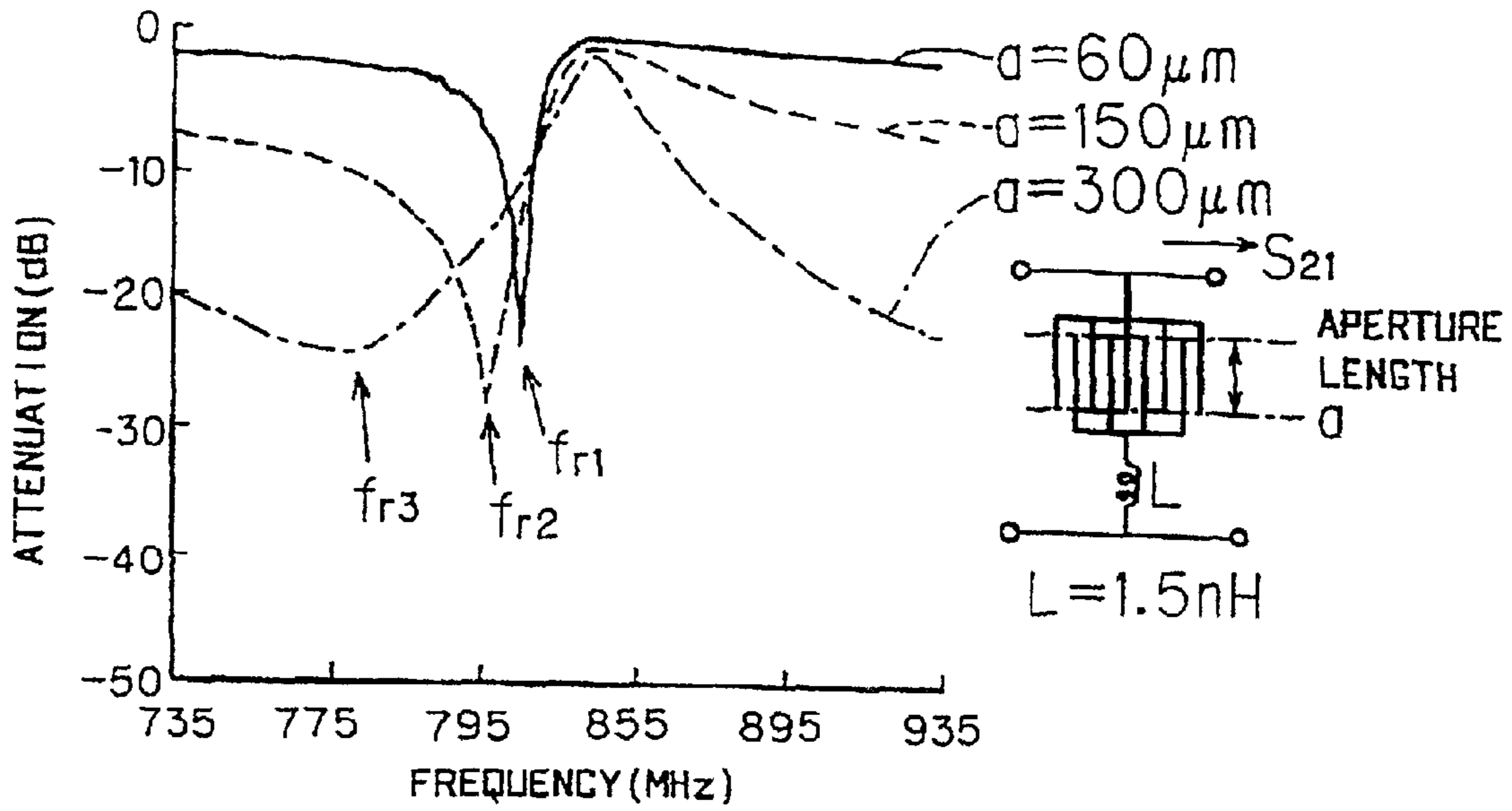

FIG. IIB

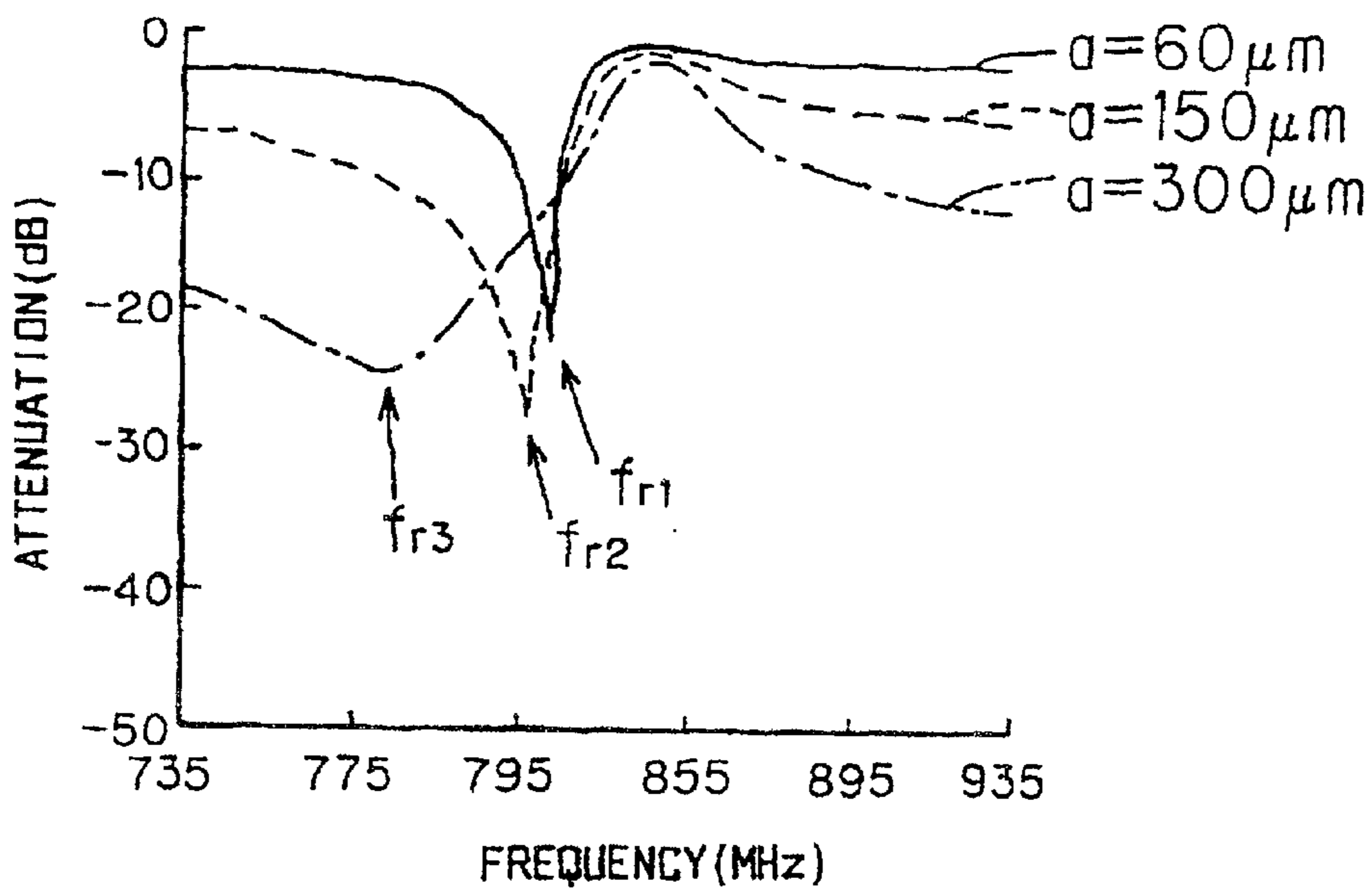

FIG. 12A

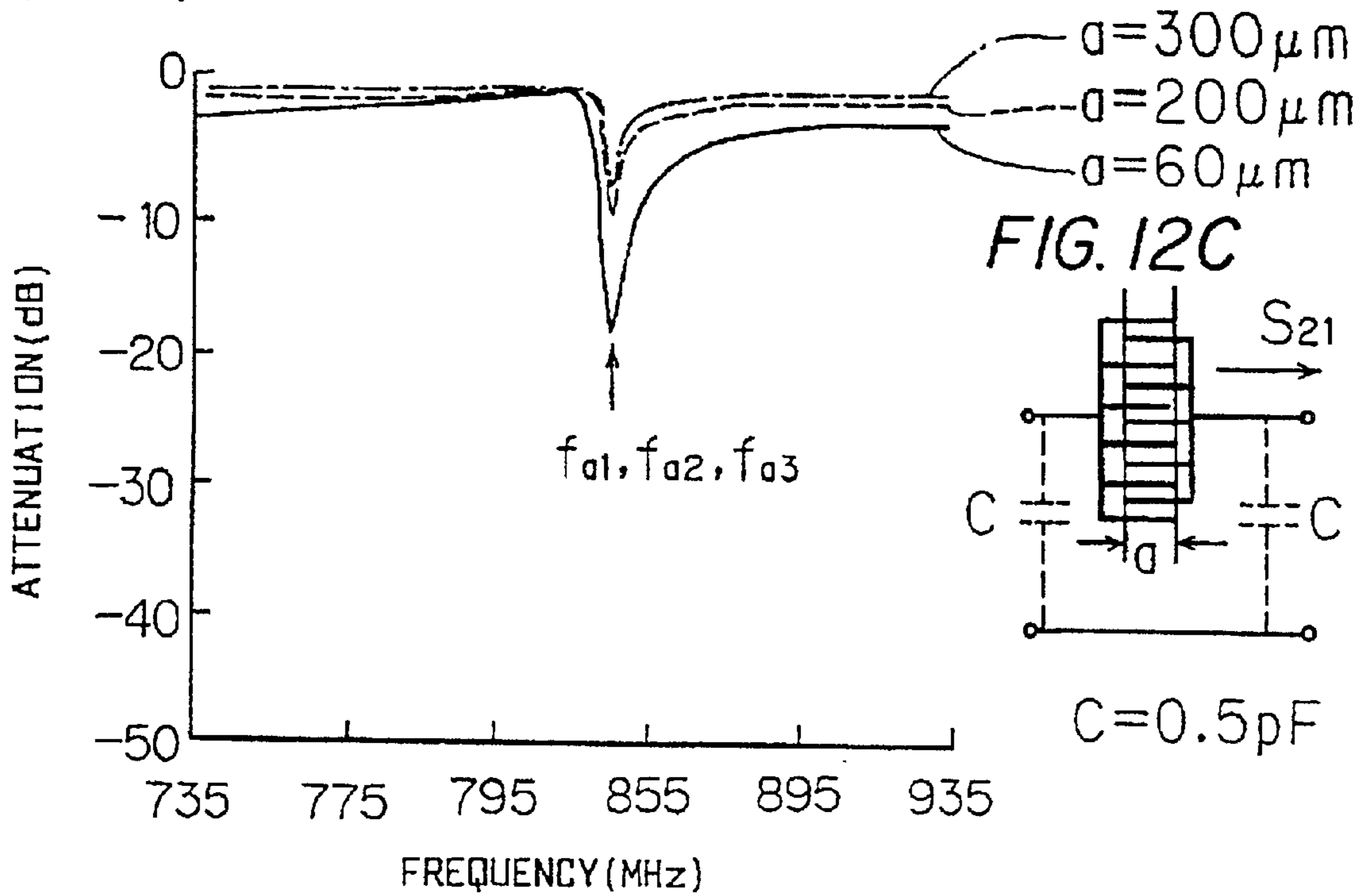

FIG. 12B

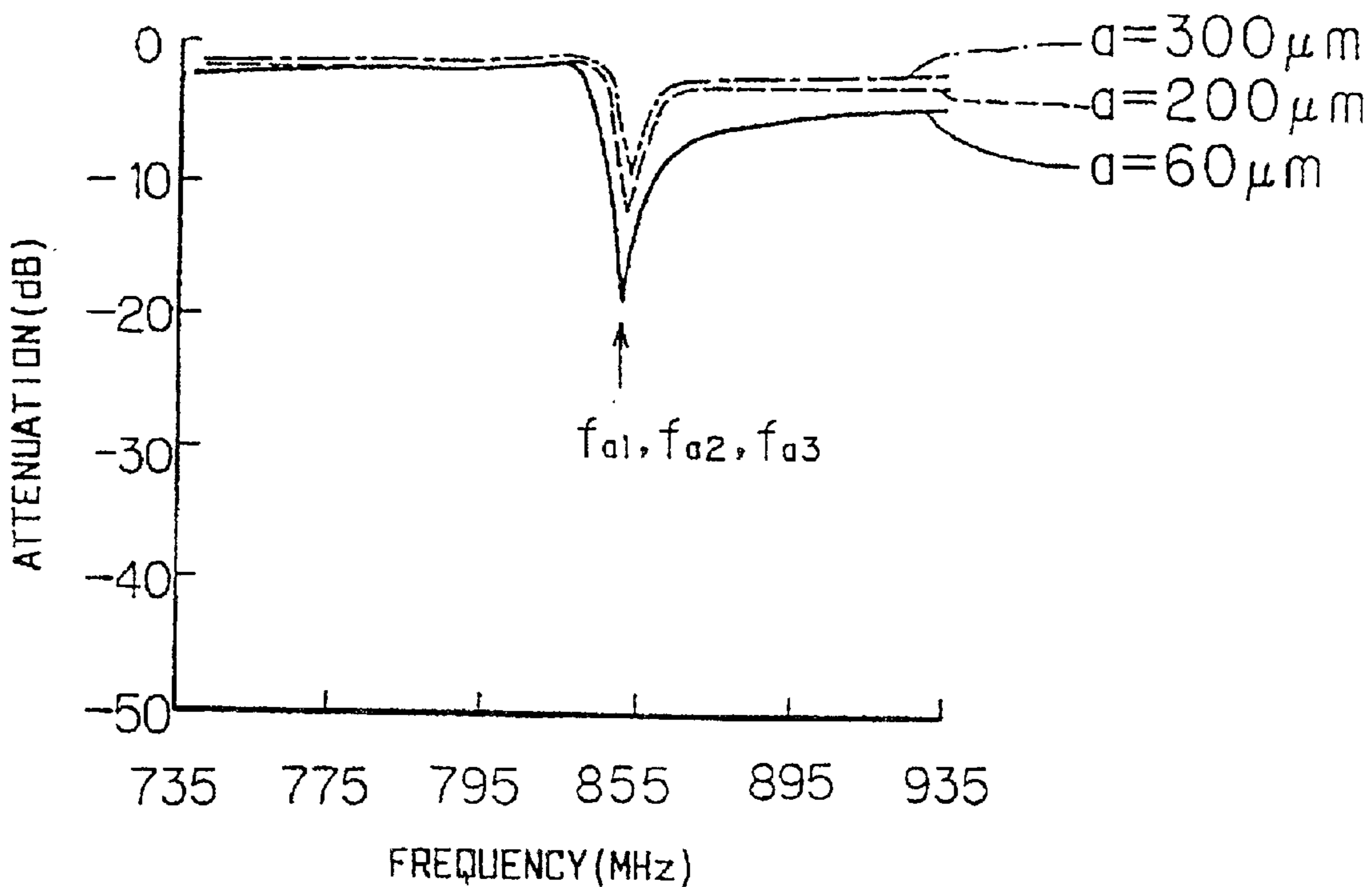

FIG. 13

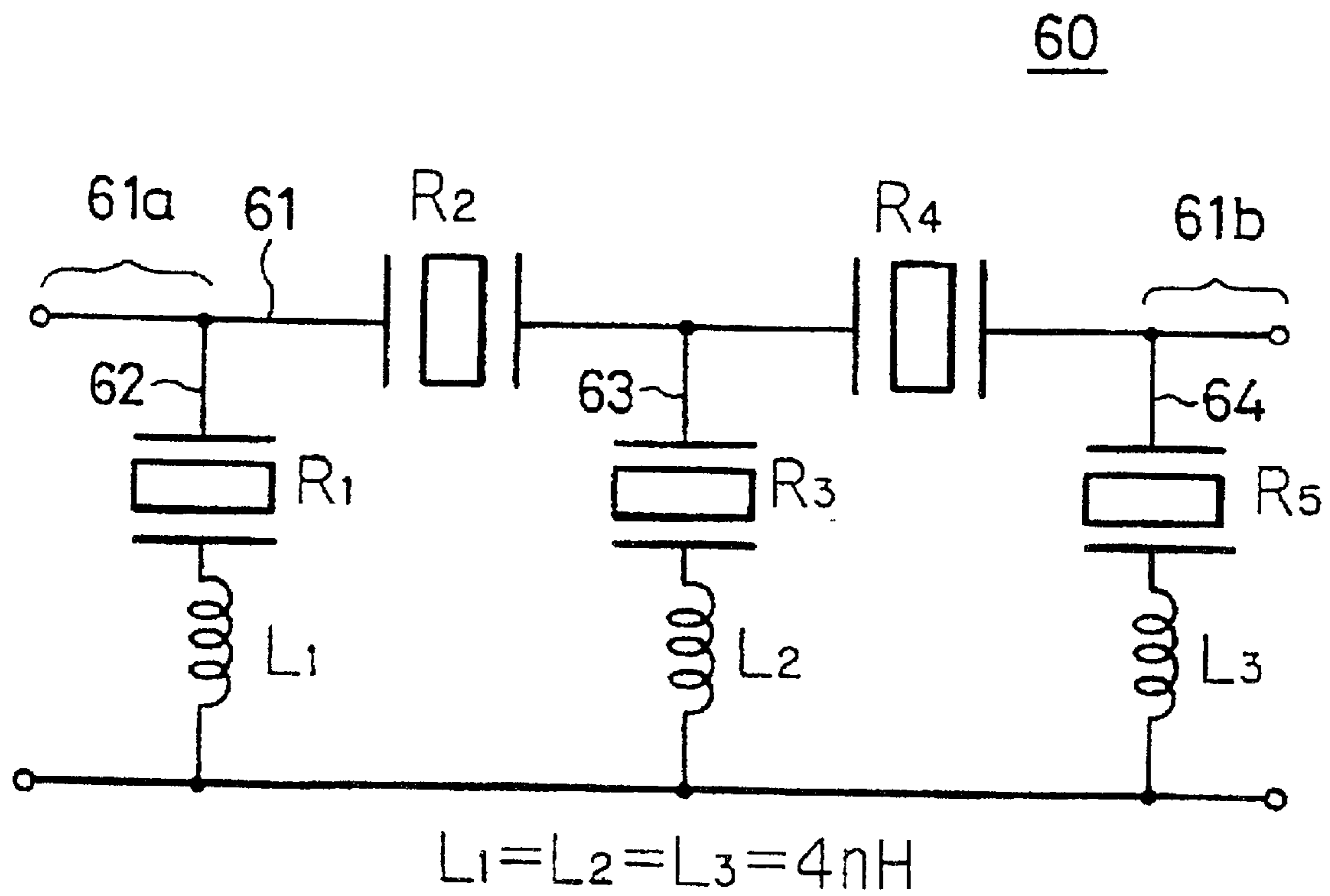

FIG. 14

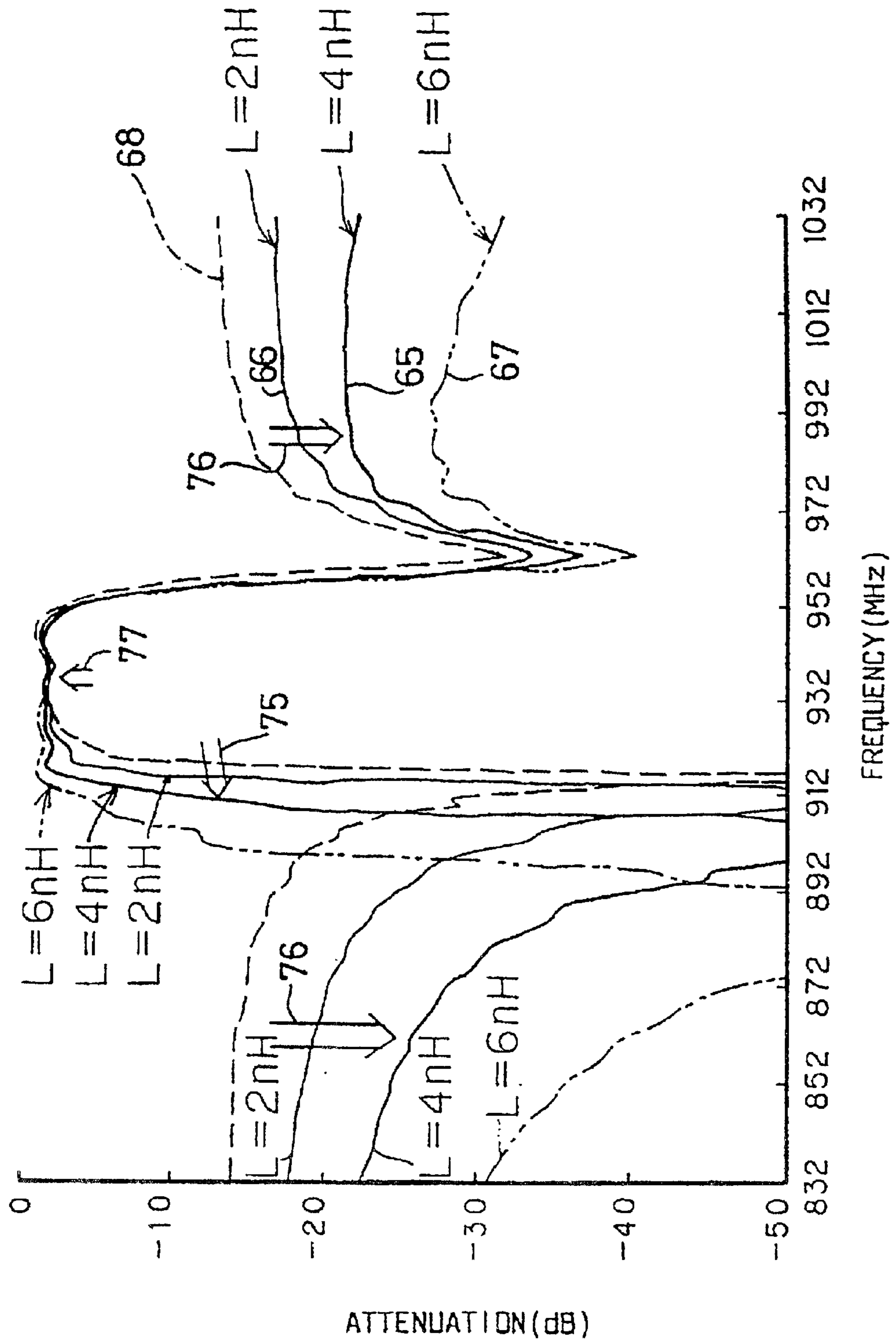

FIG. 15A

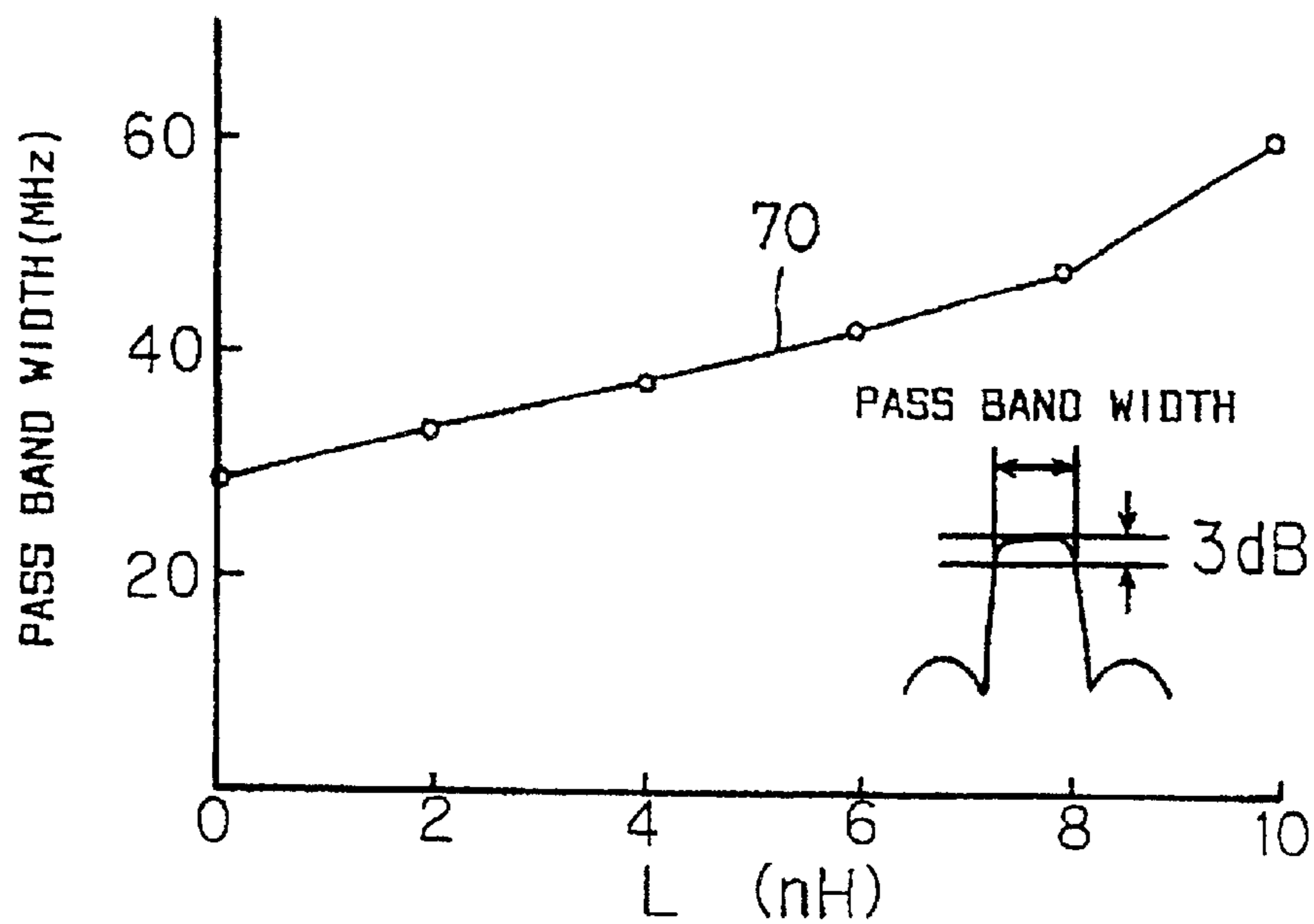

FIG. 15B

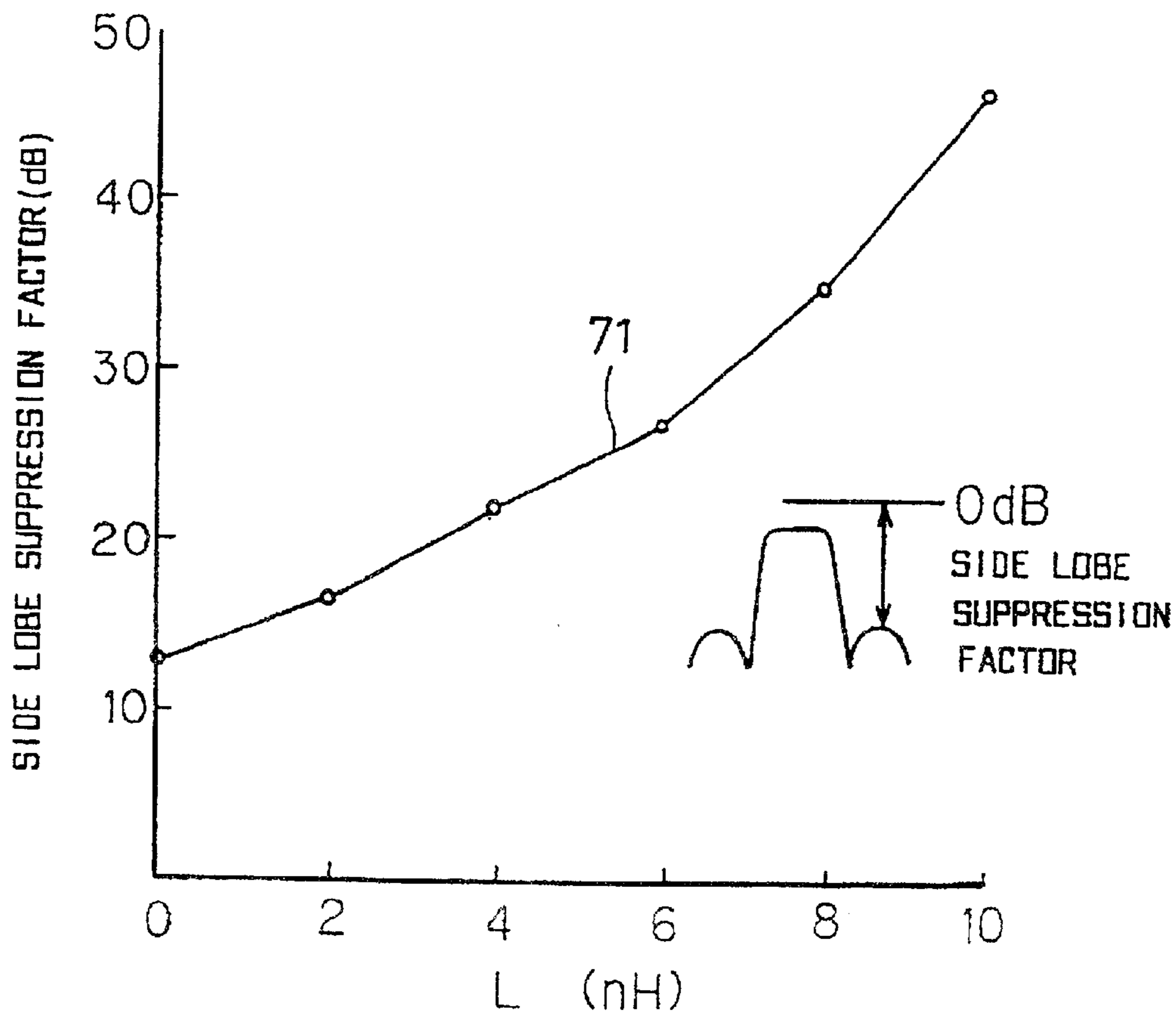

FIG. 16

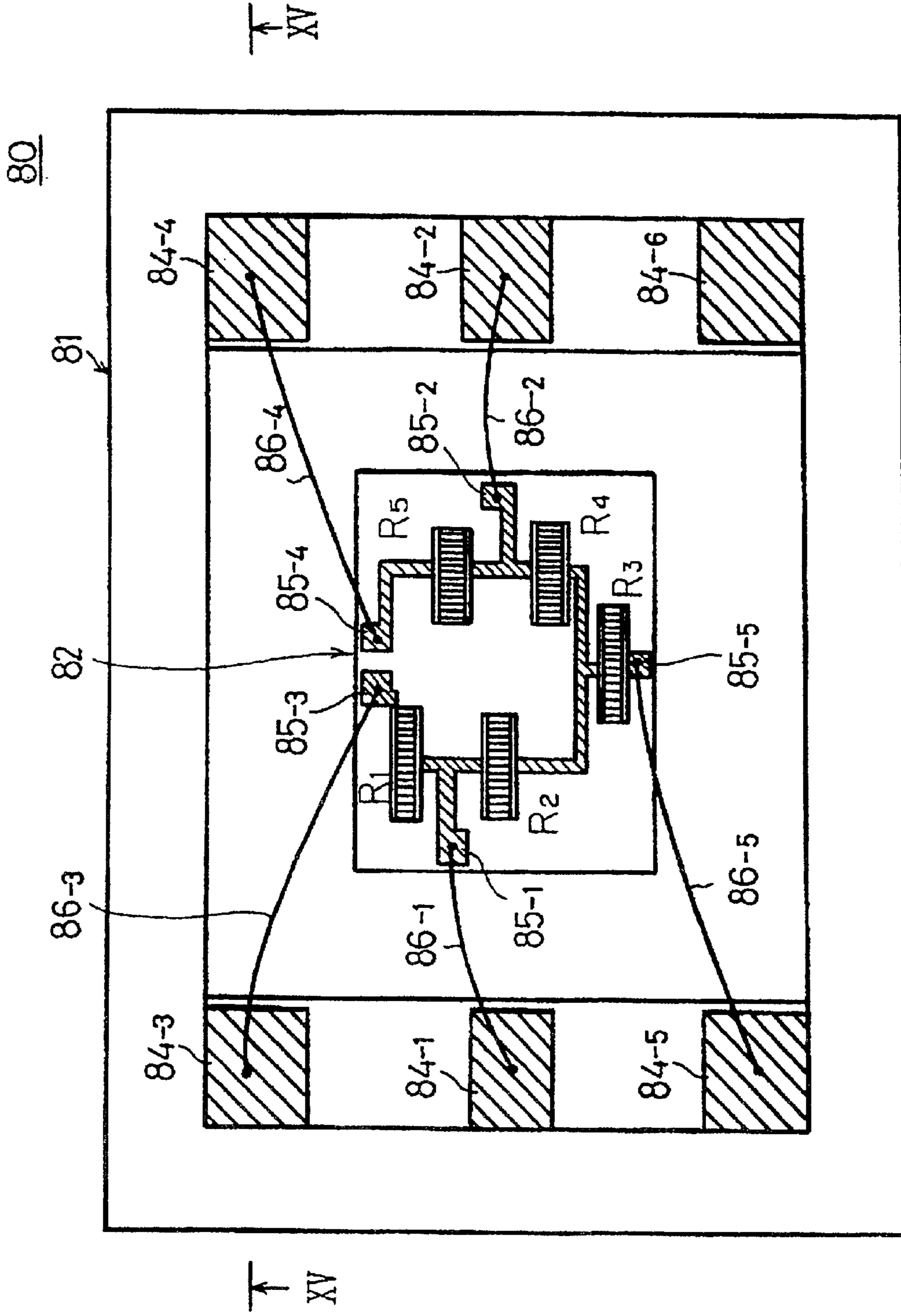

FIG. 17

80

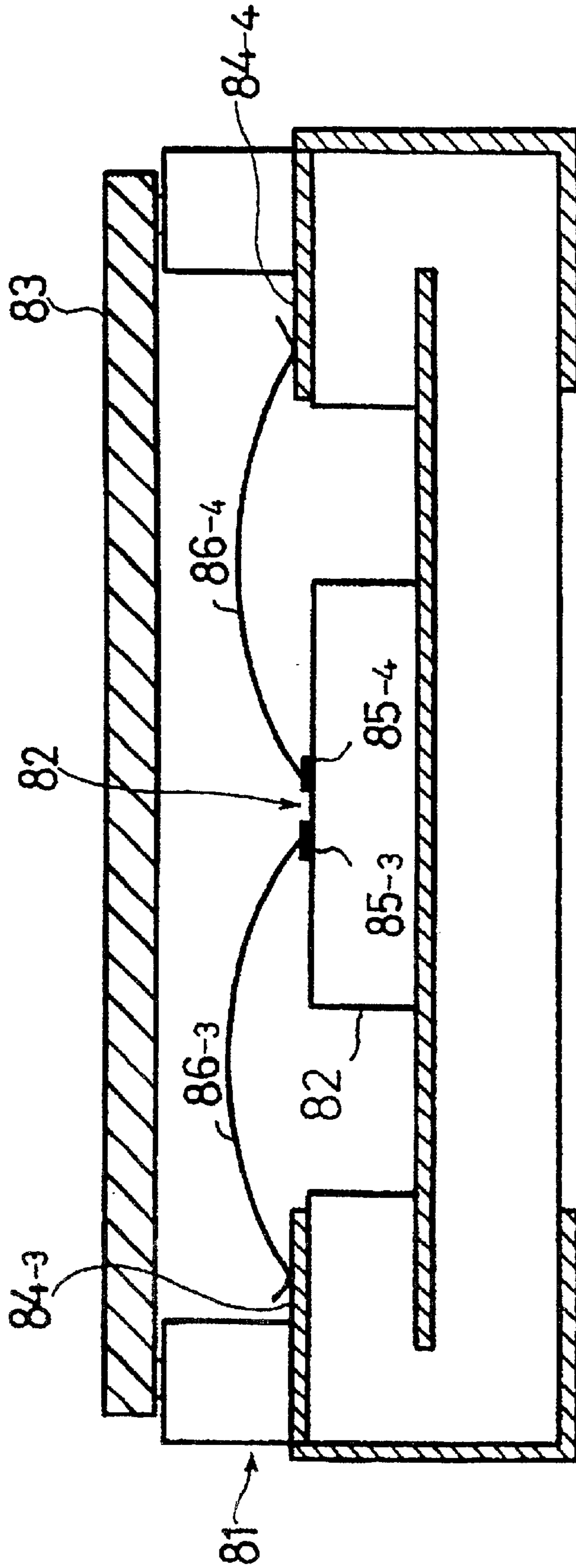

FIG. 18

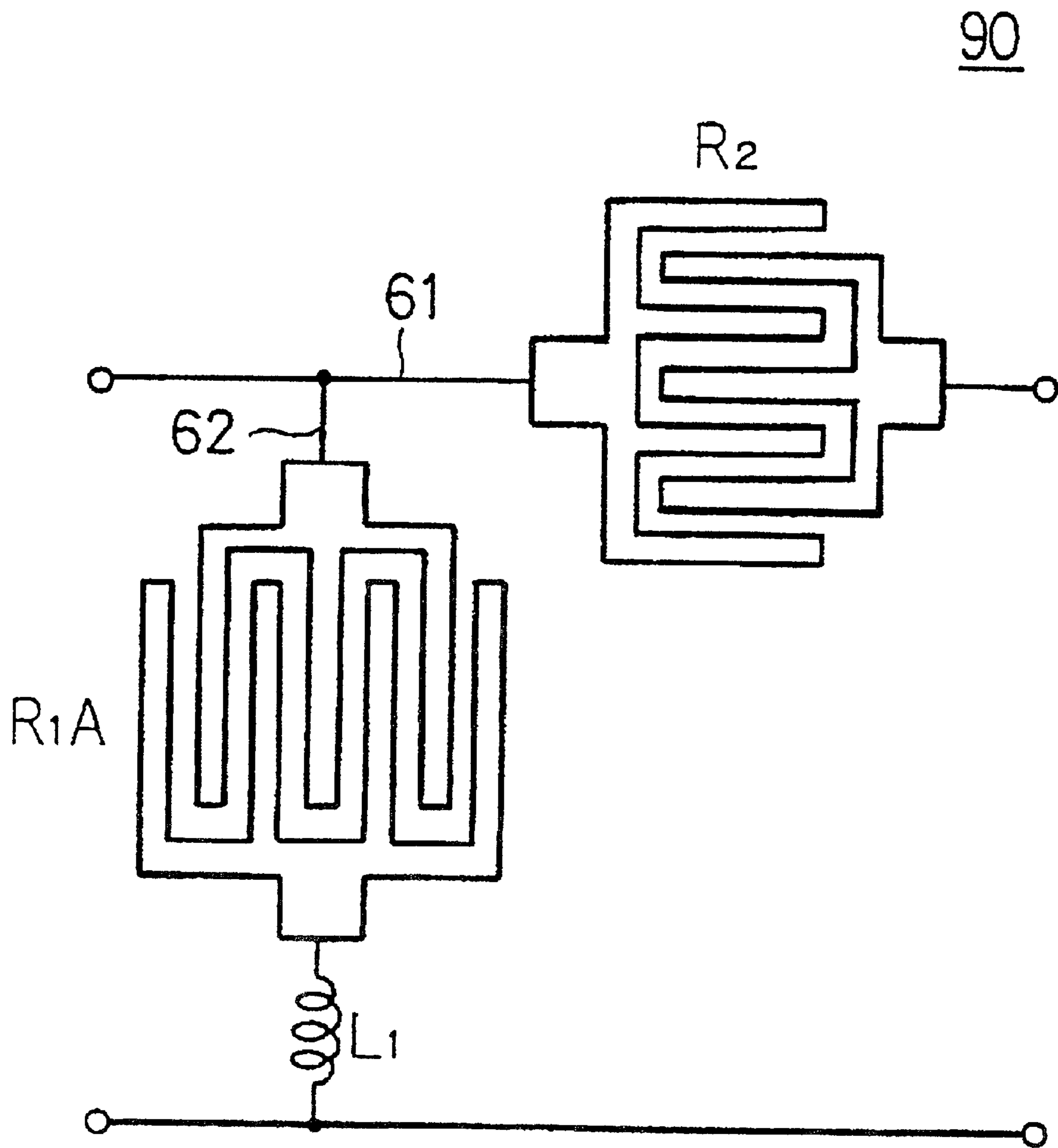

FIG. 19

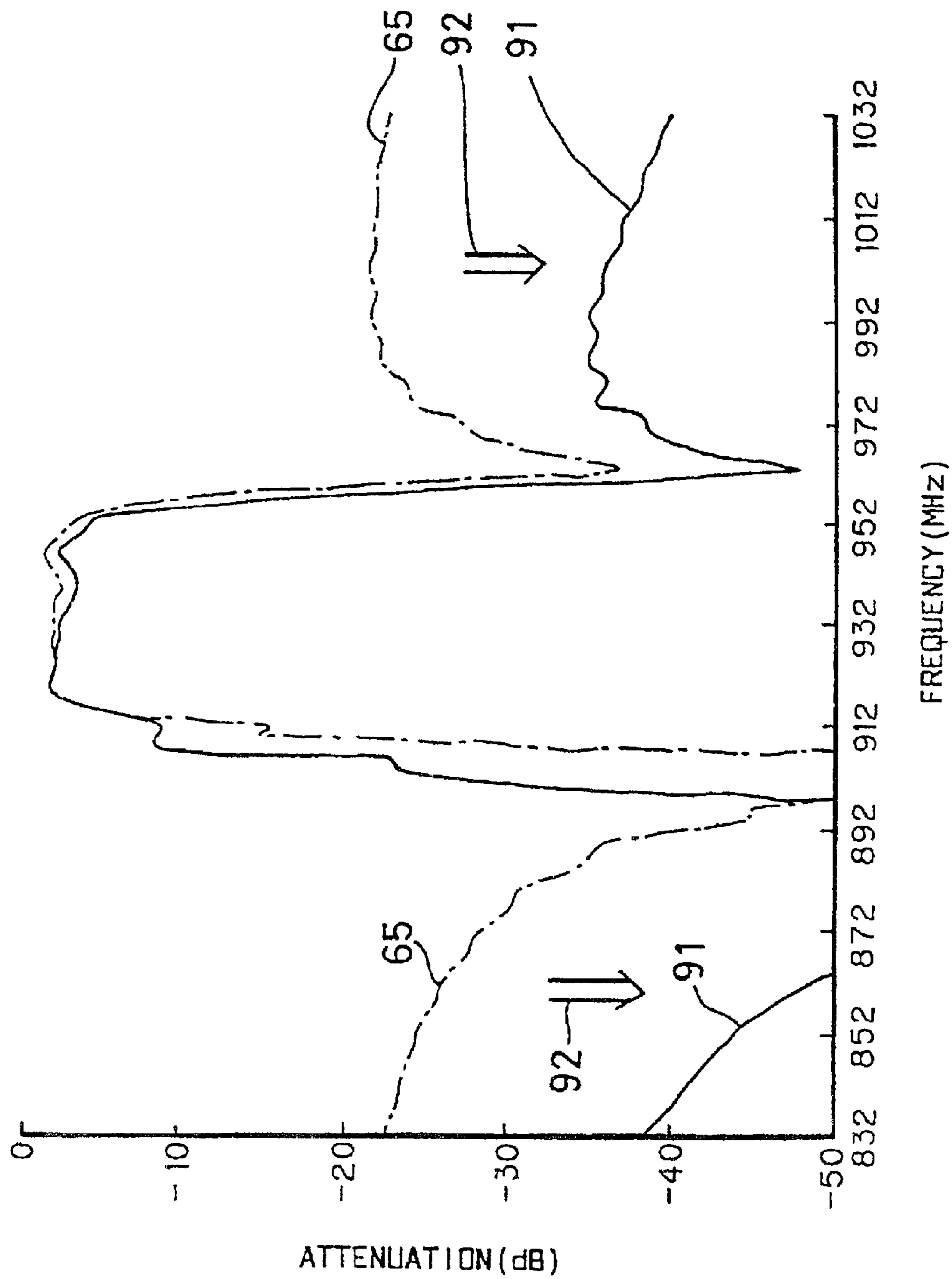

FIG. 20A

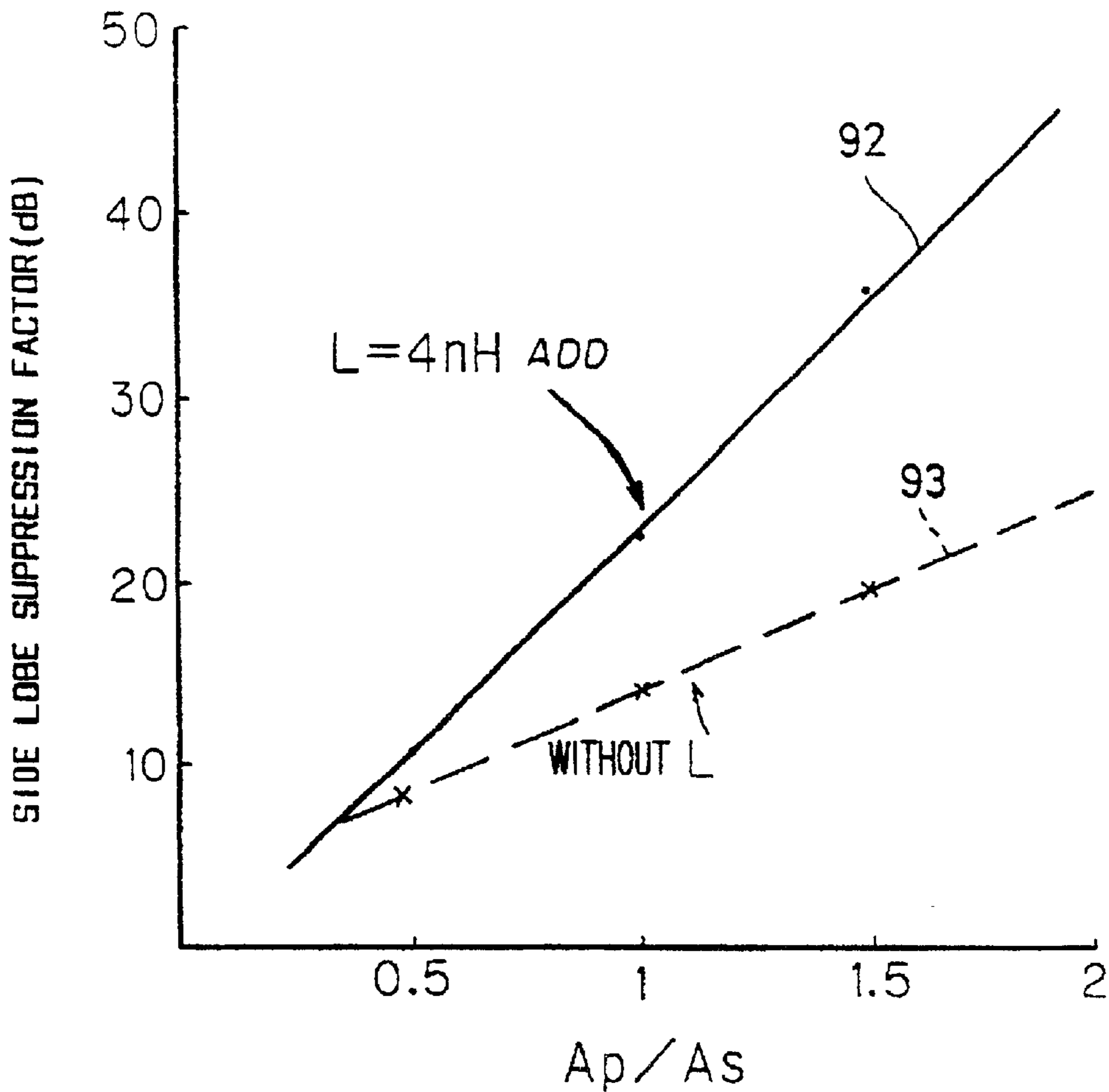

FIG. 20B

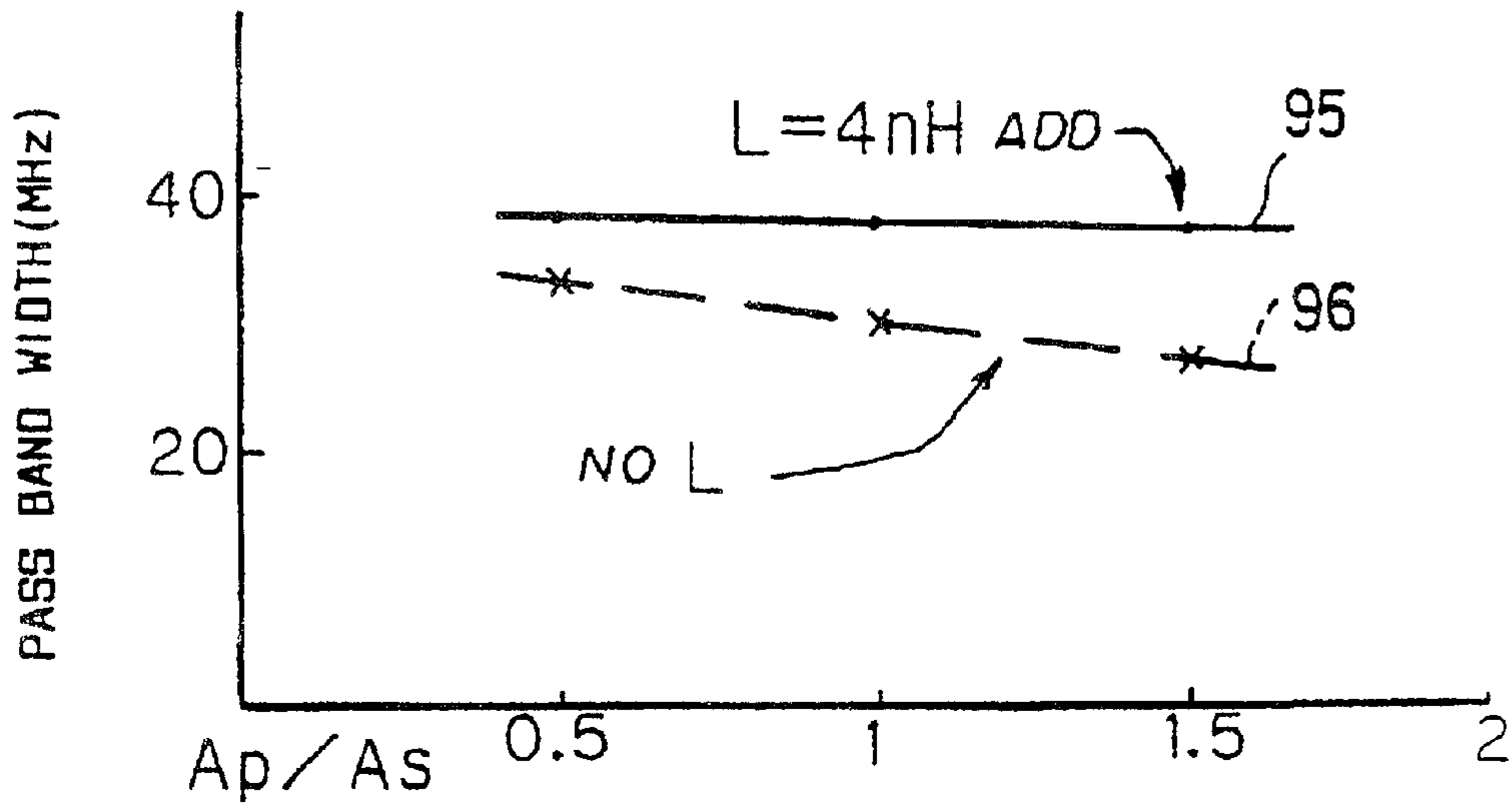

FIG. 21

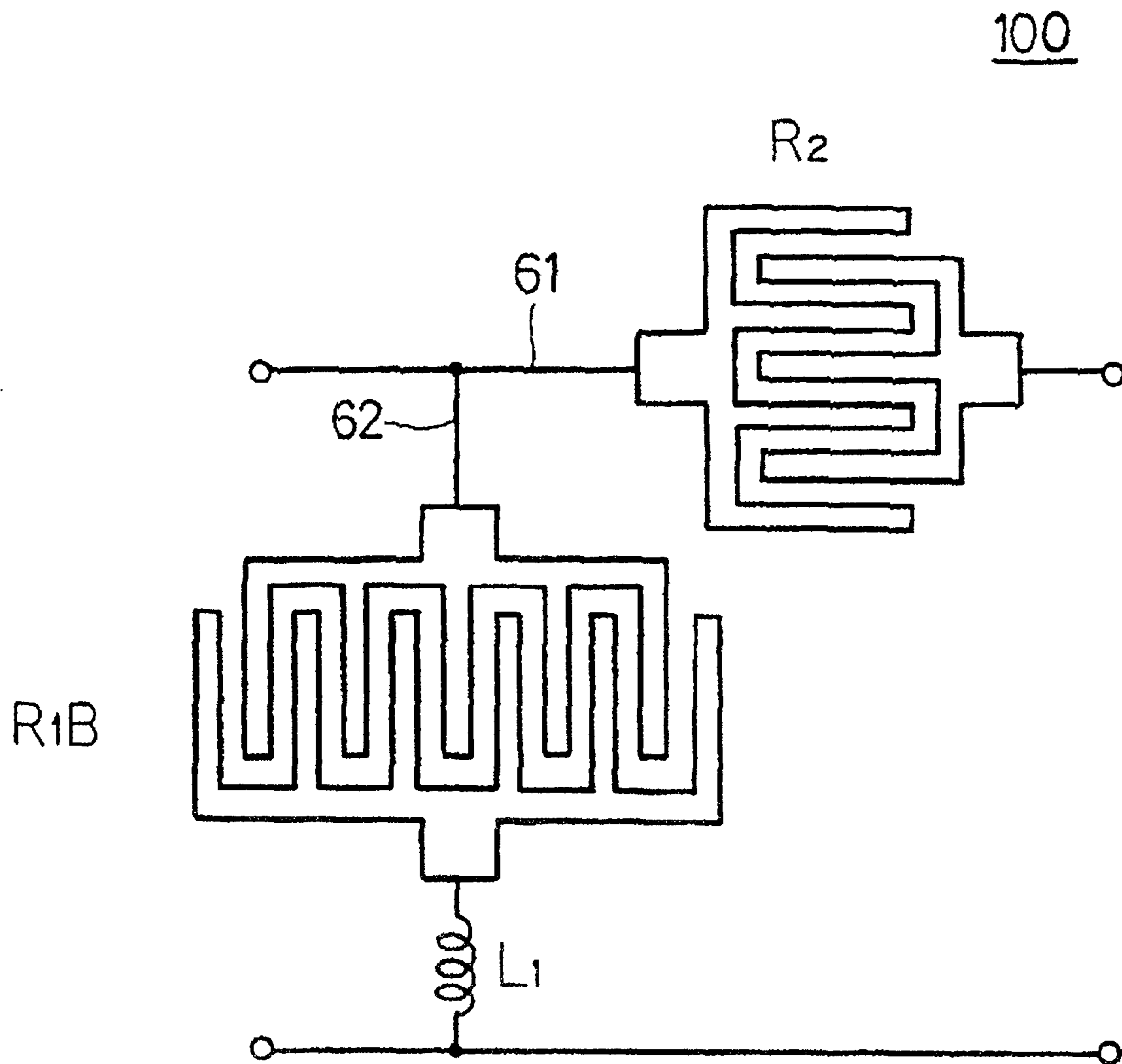

FIG. 22

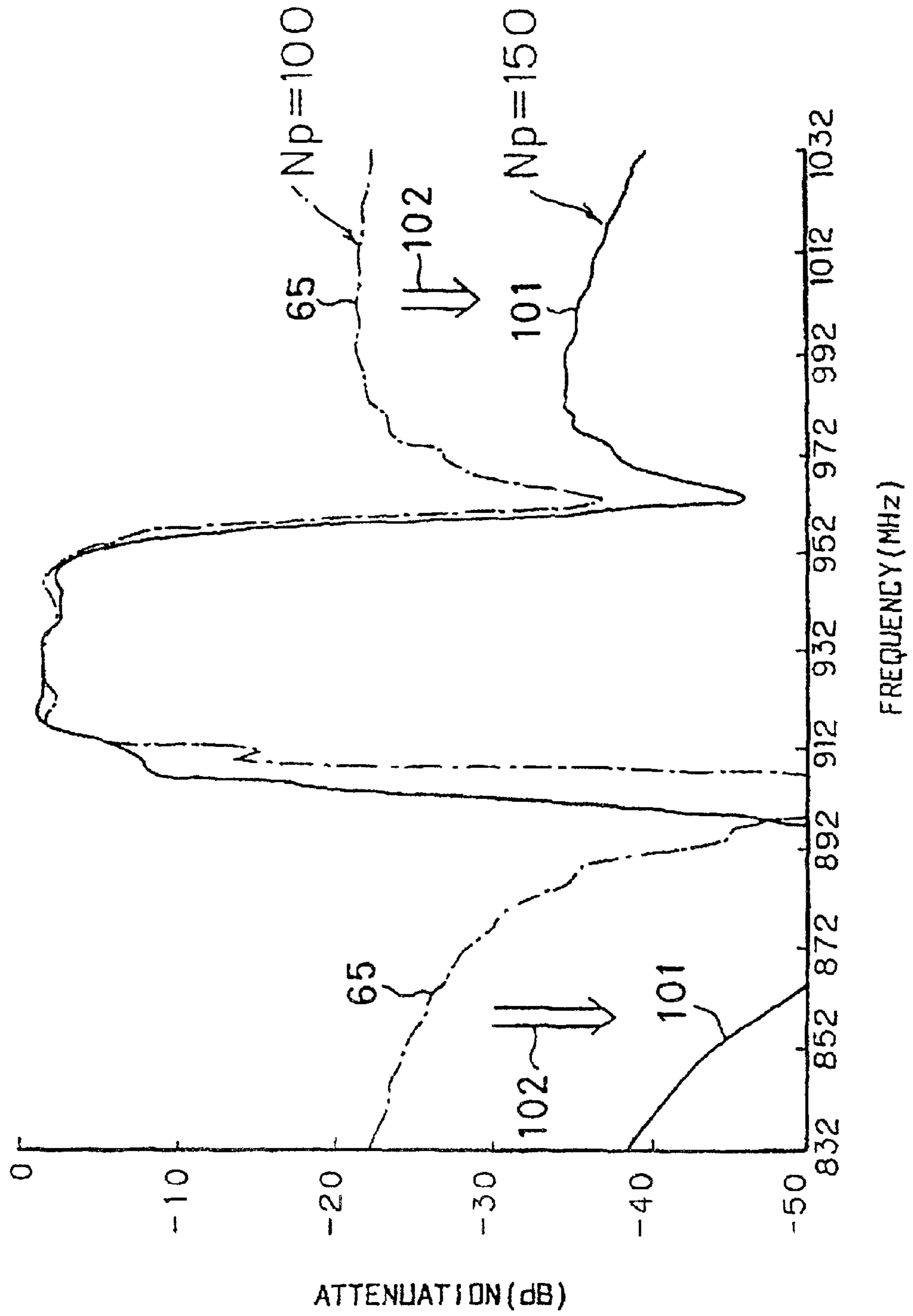

FIG. 23

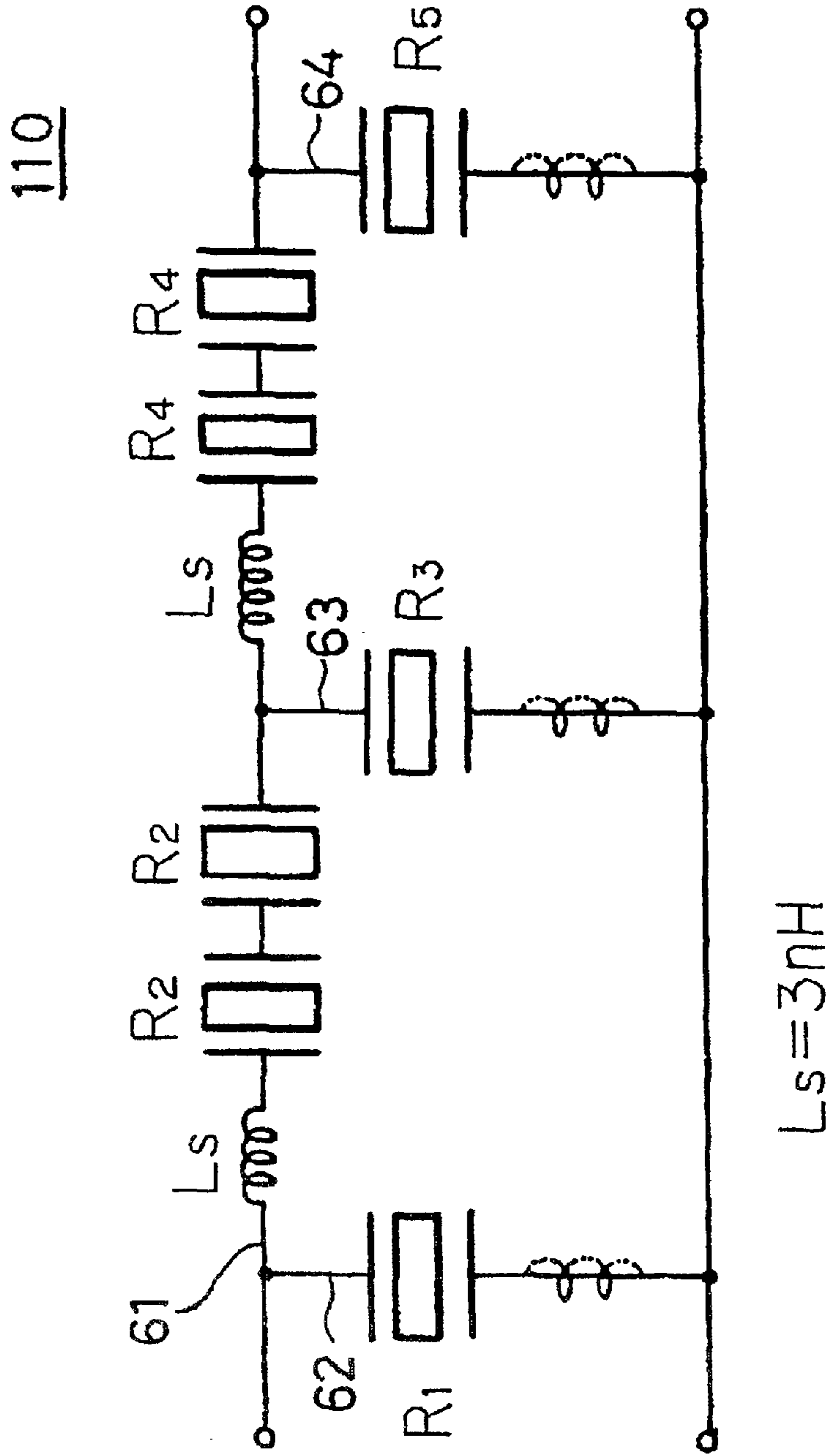

FIG. 24

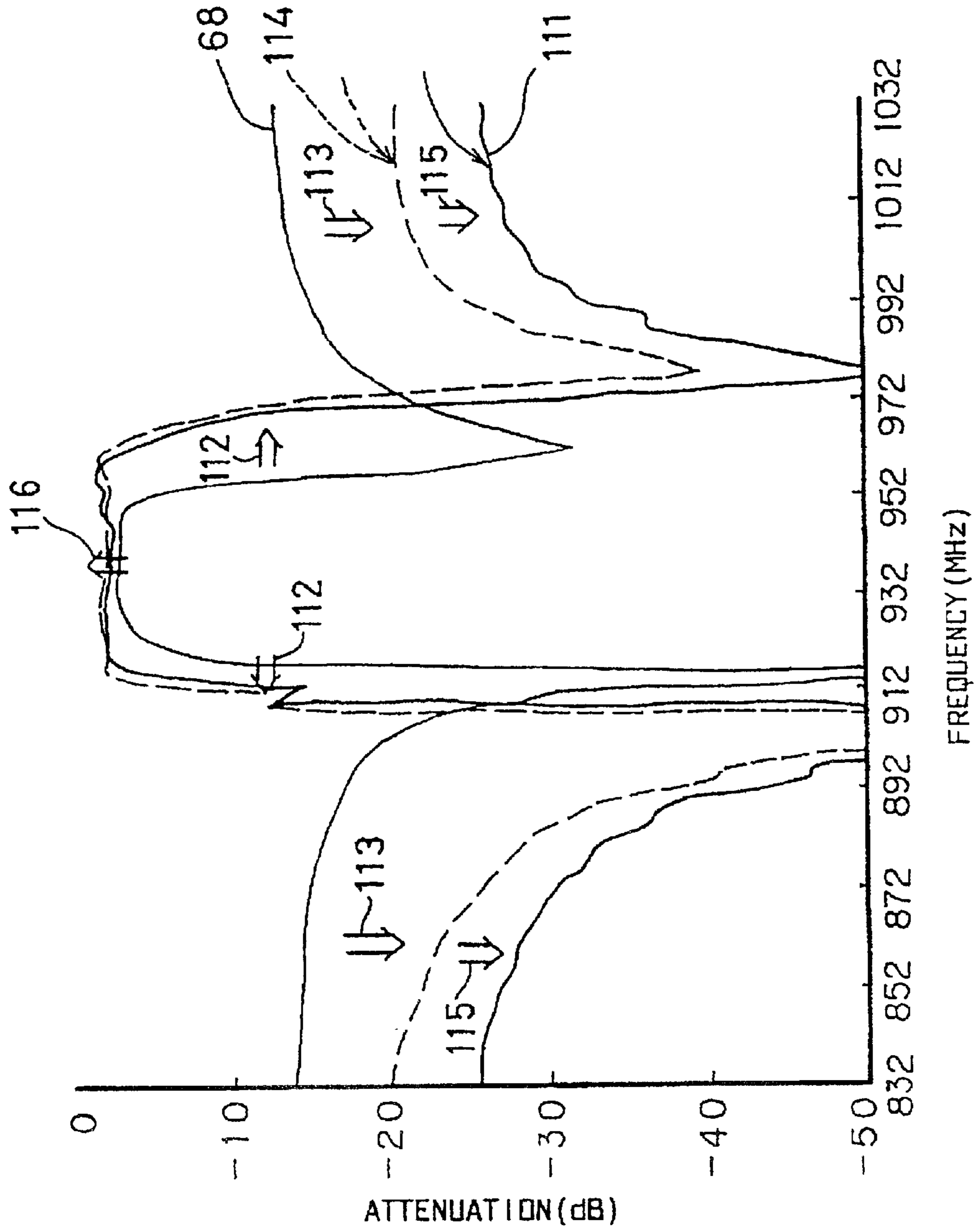

FIG. 25

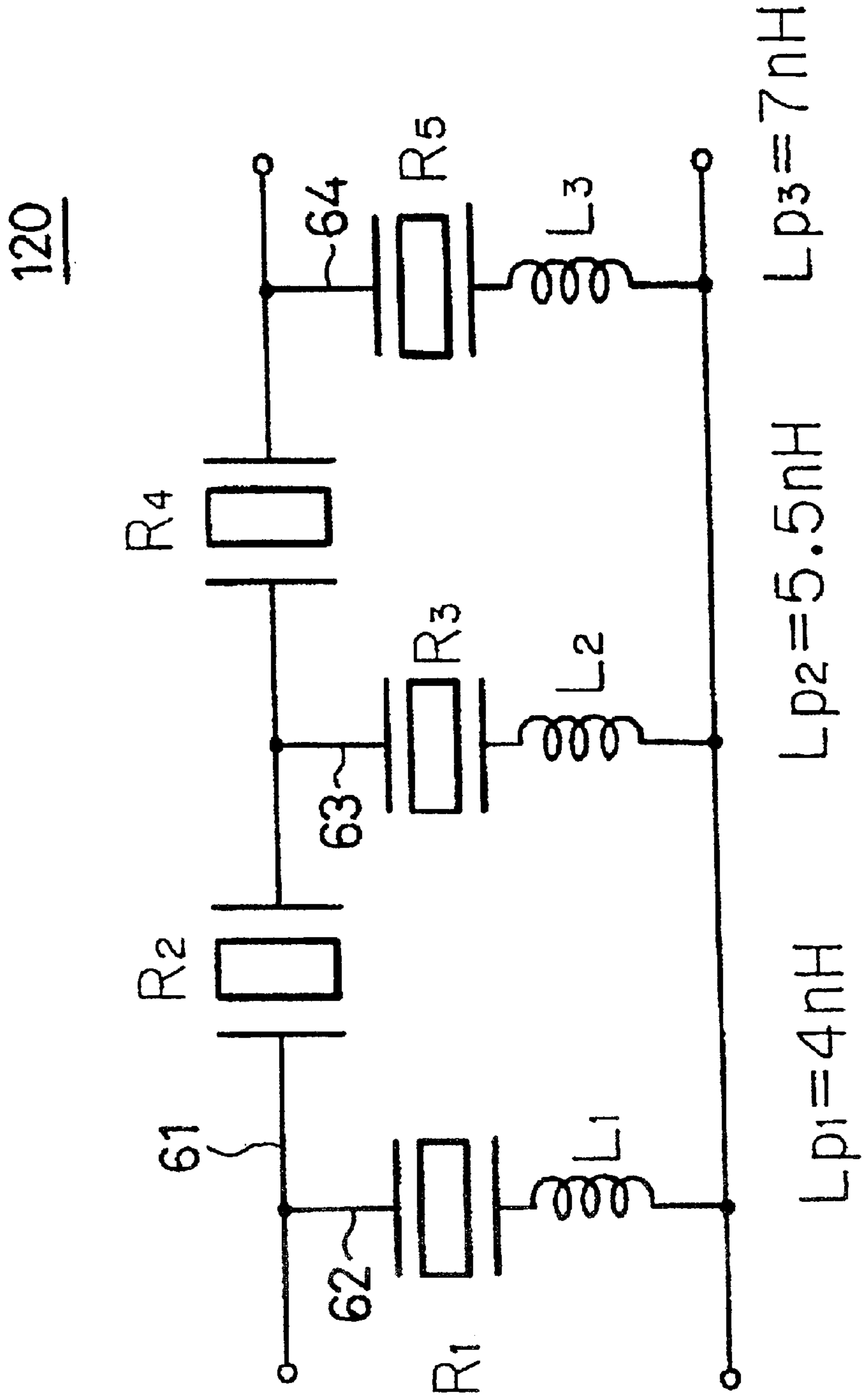

FIG. 26

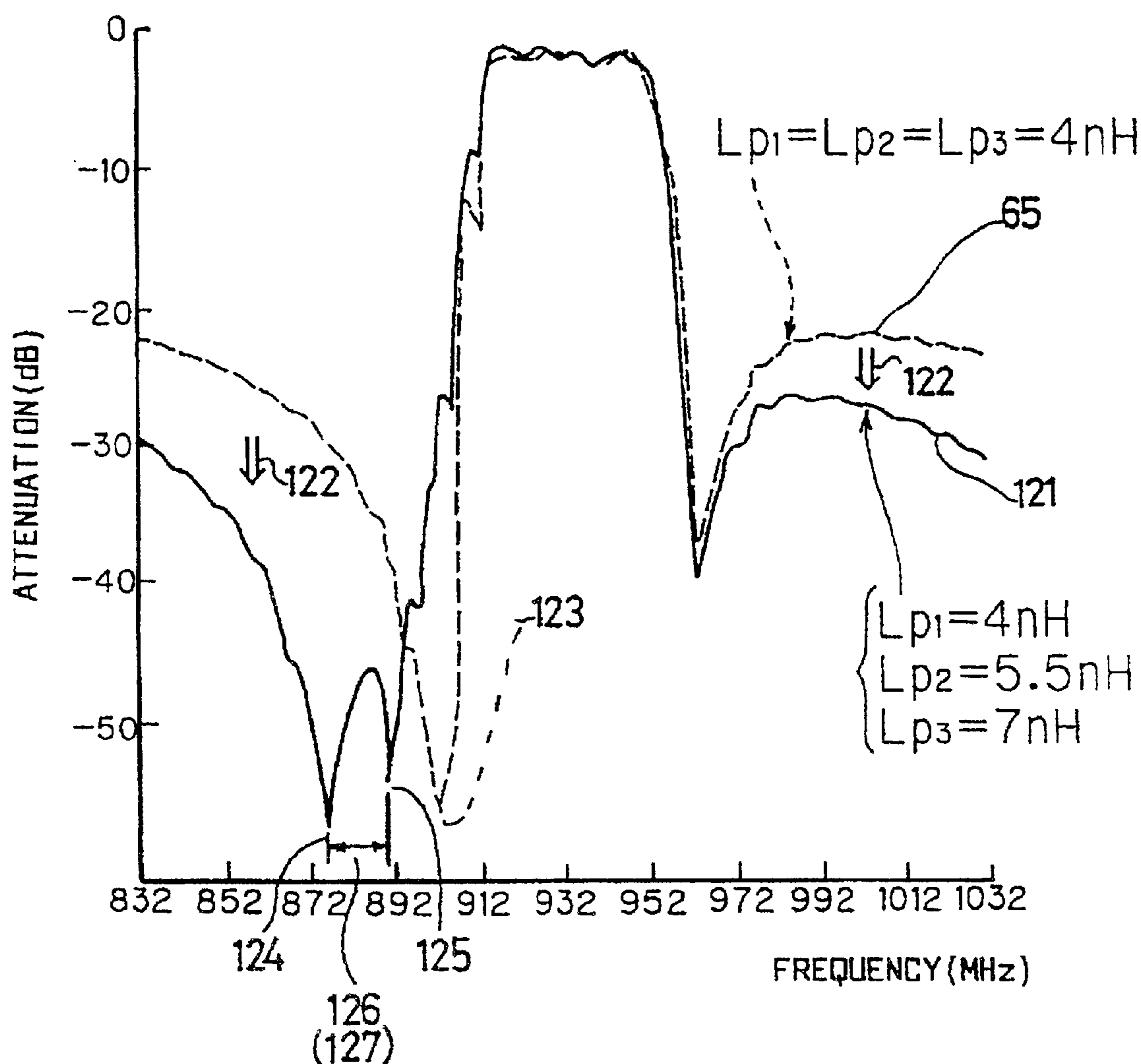

FIG. 27

130

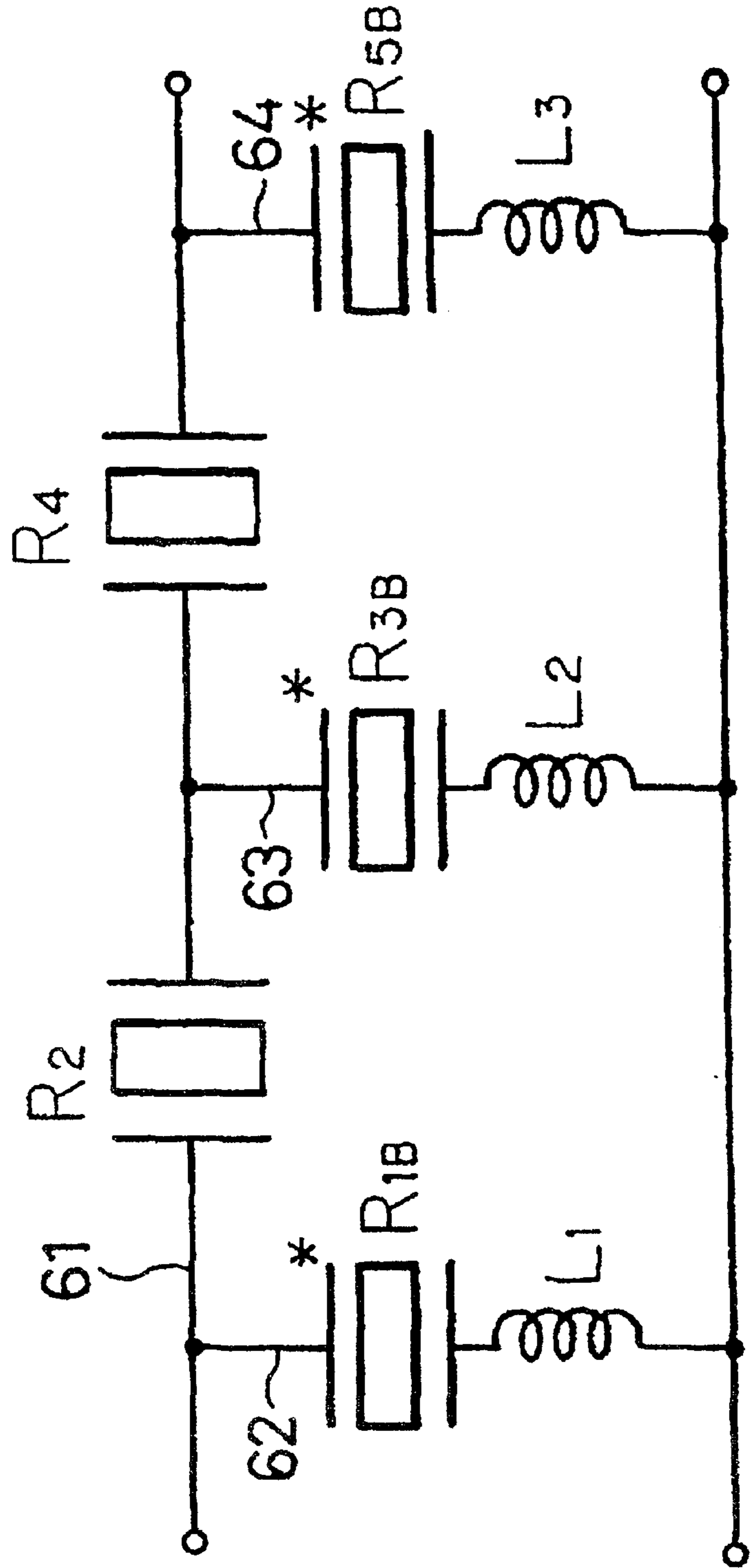

FIG. 28

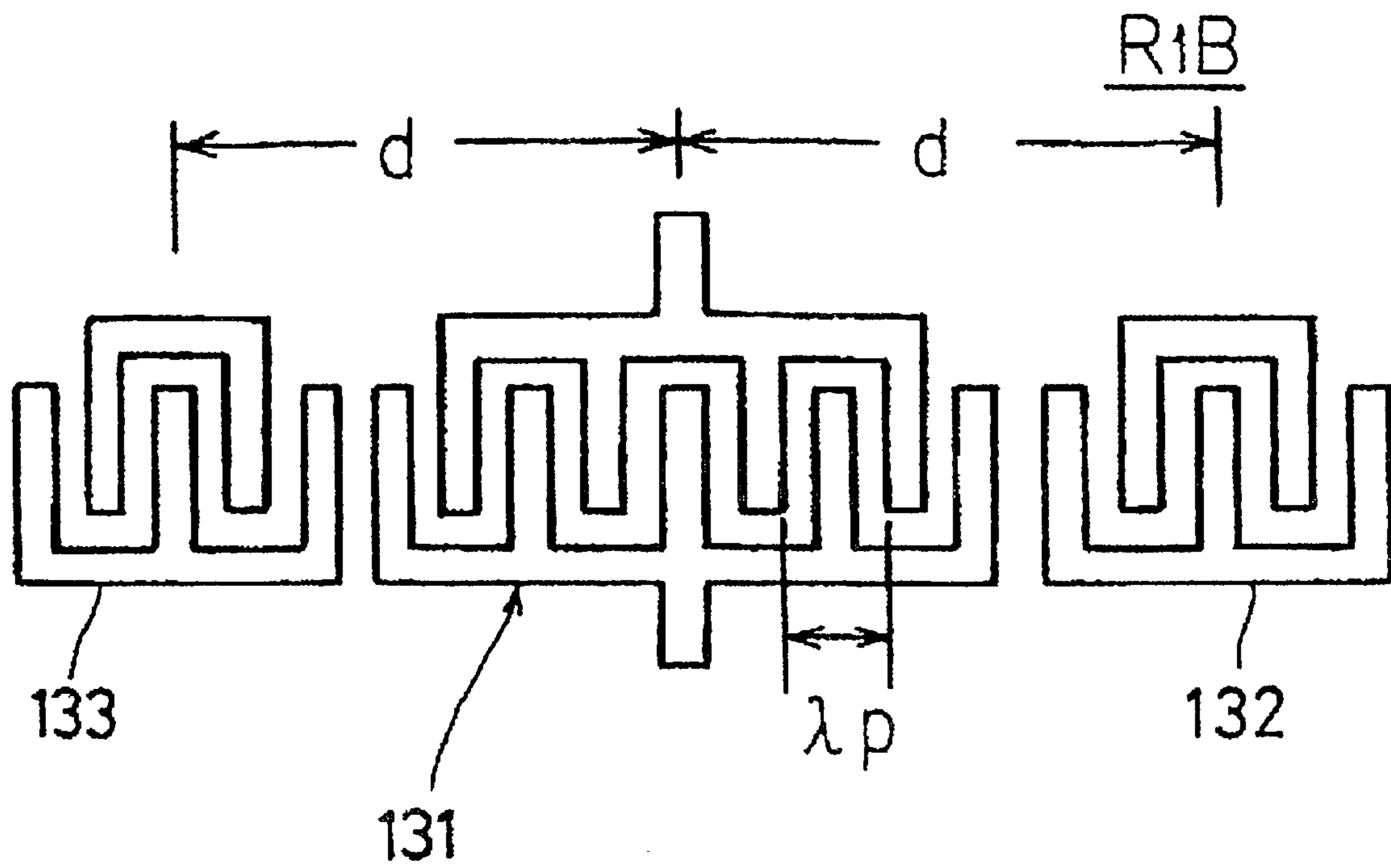

FIG. 29

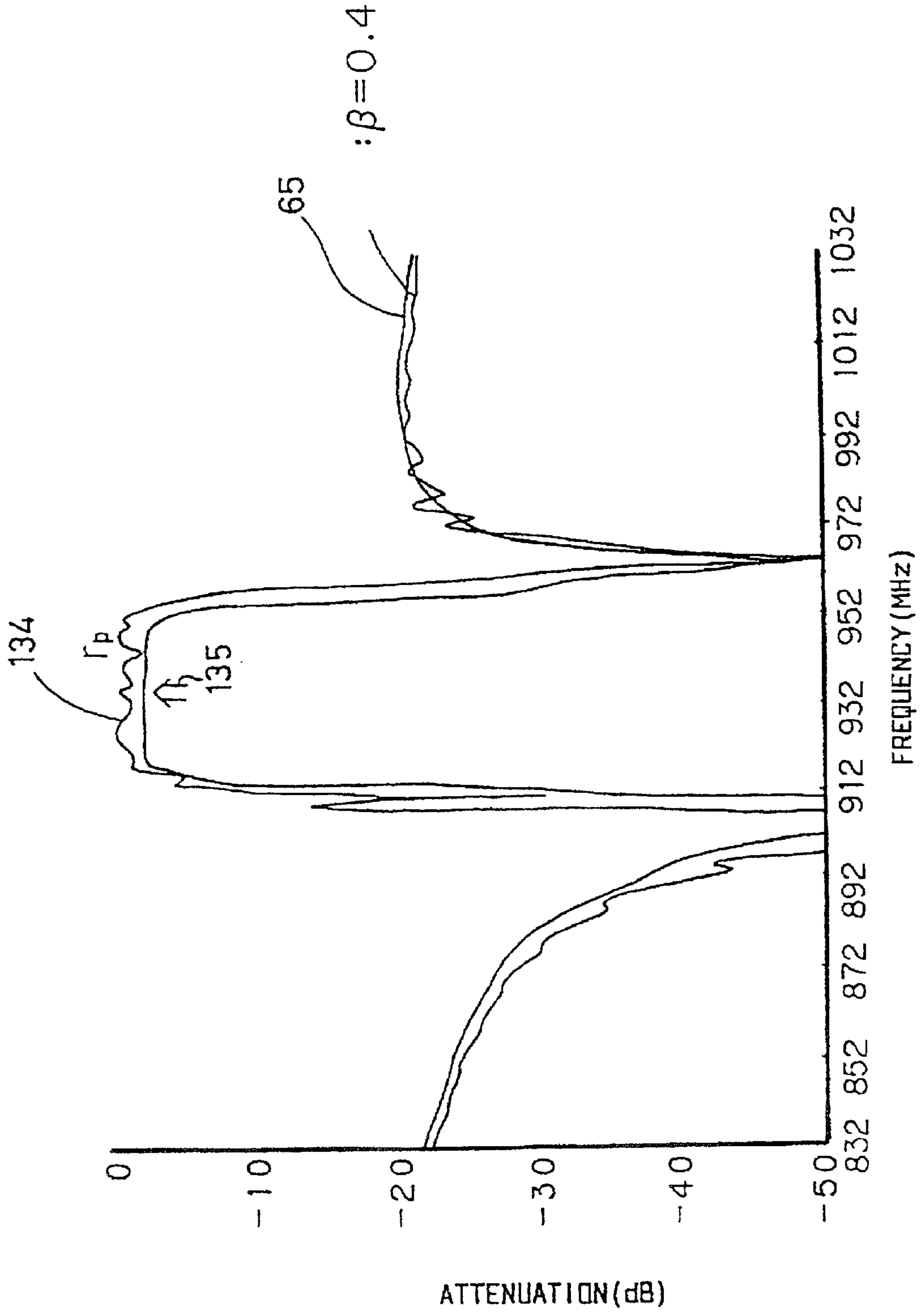

FIG. 30

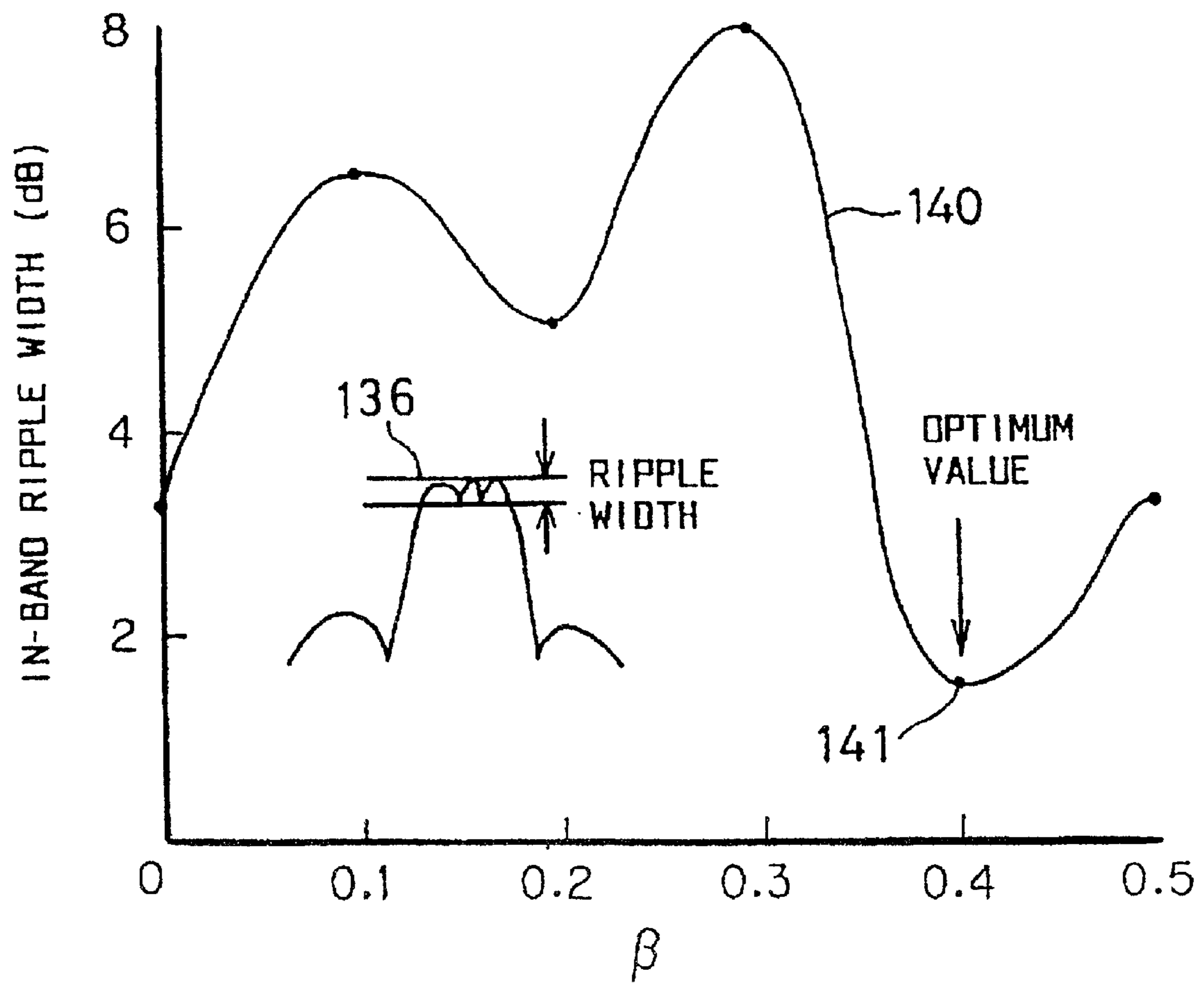

FIG. 31

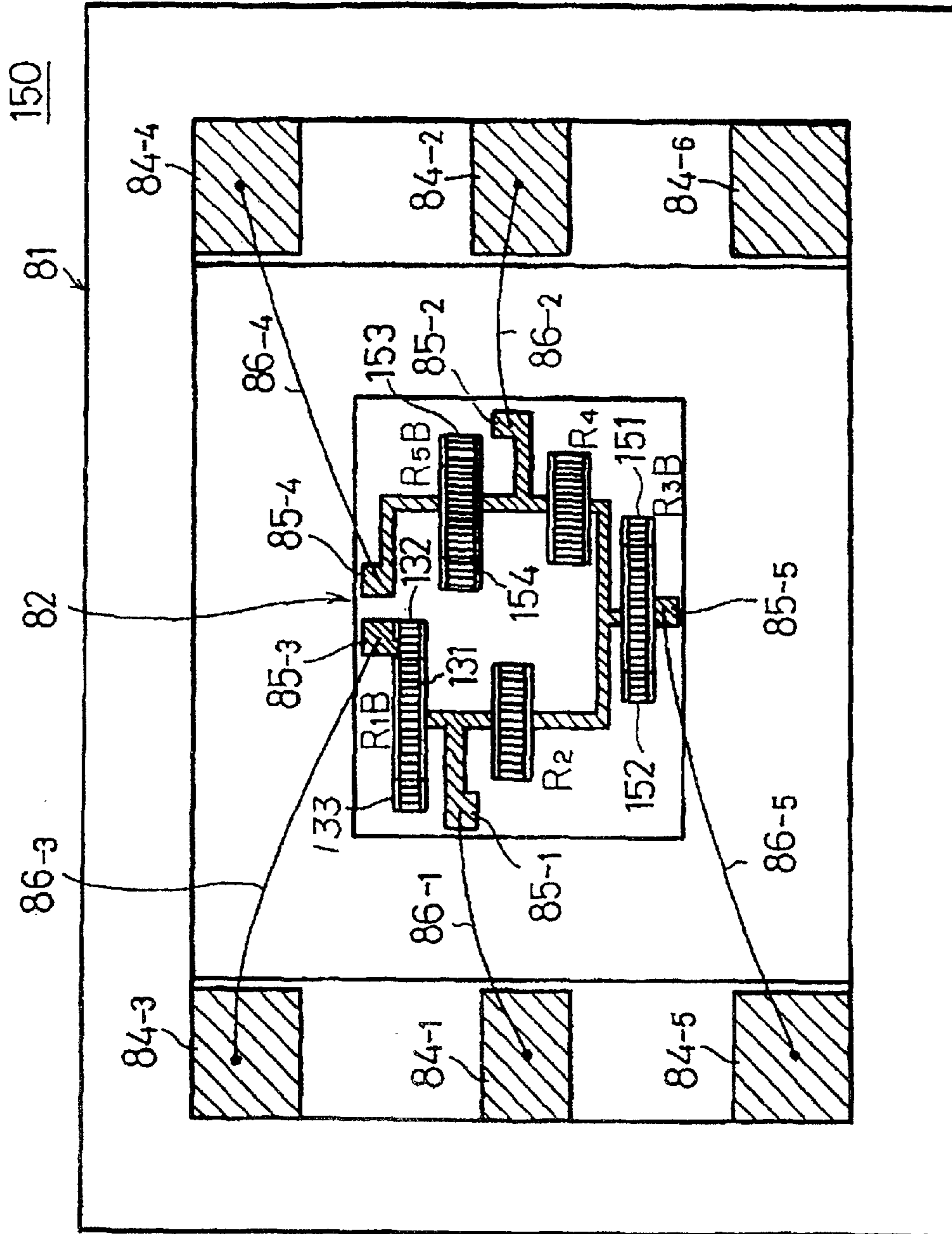

FIG. 32

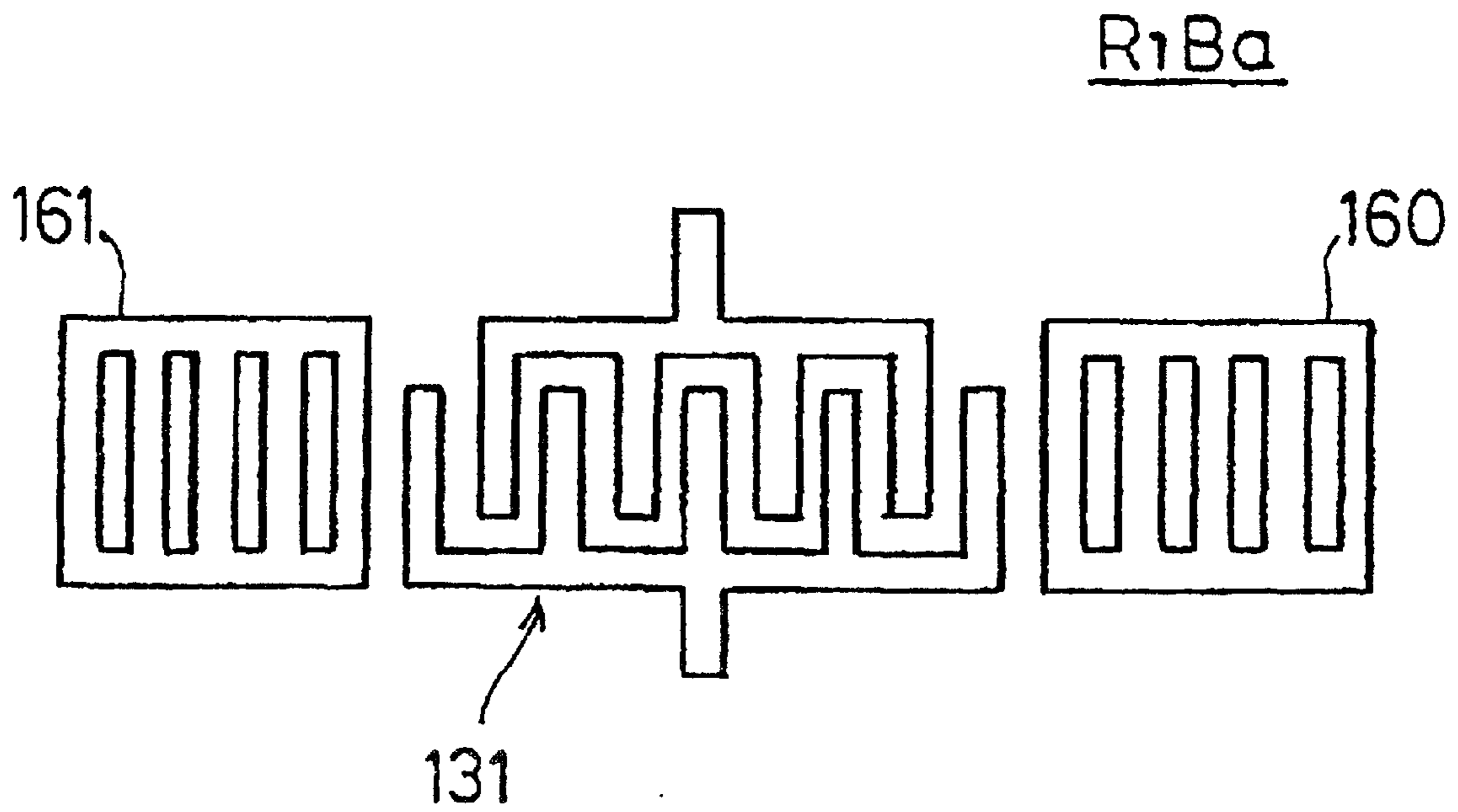

FIG. 33

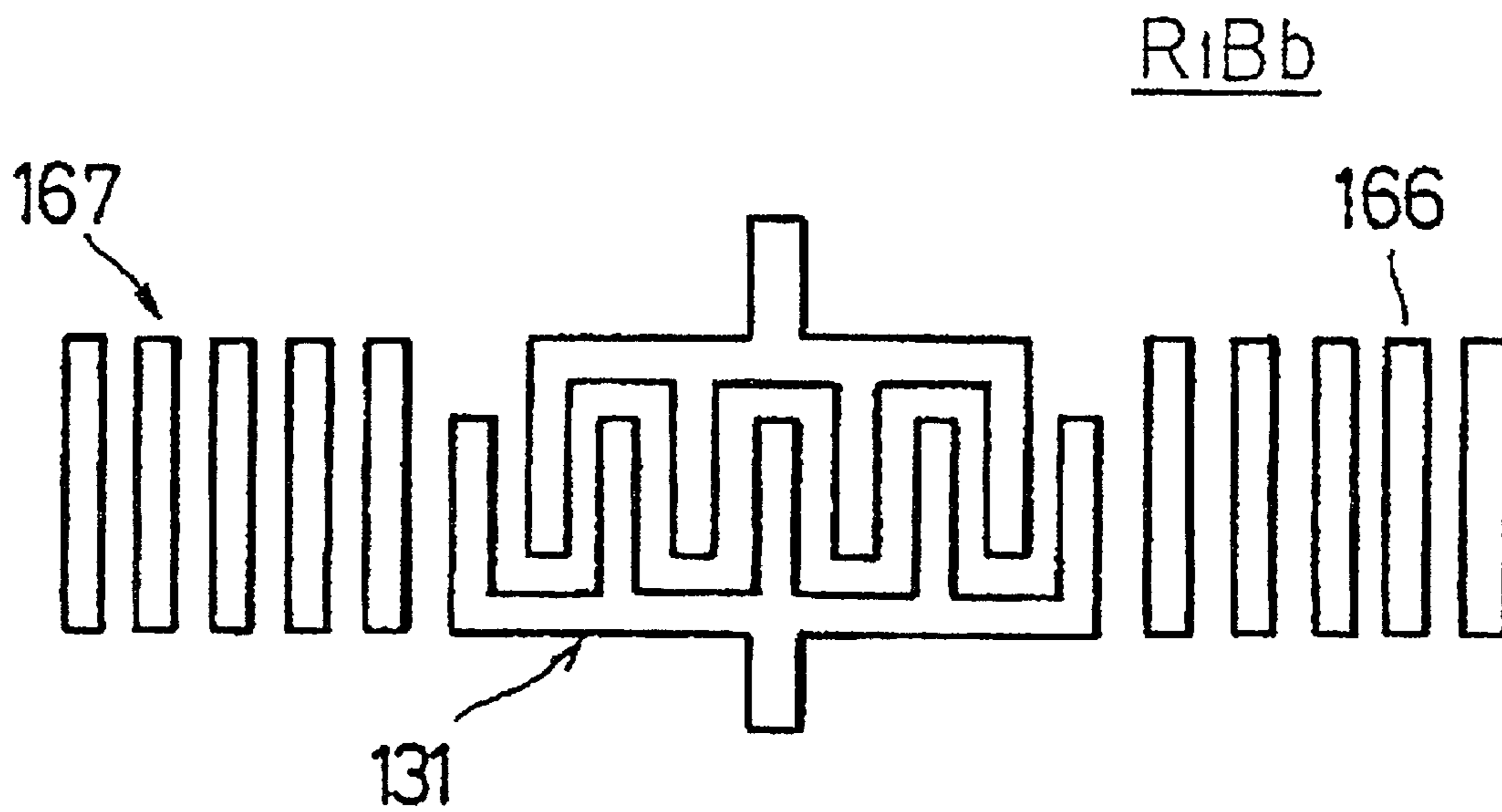

FIG. 34

170

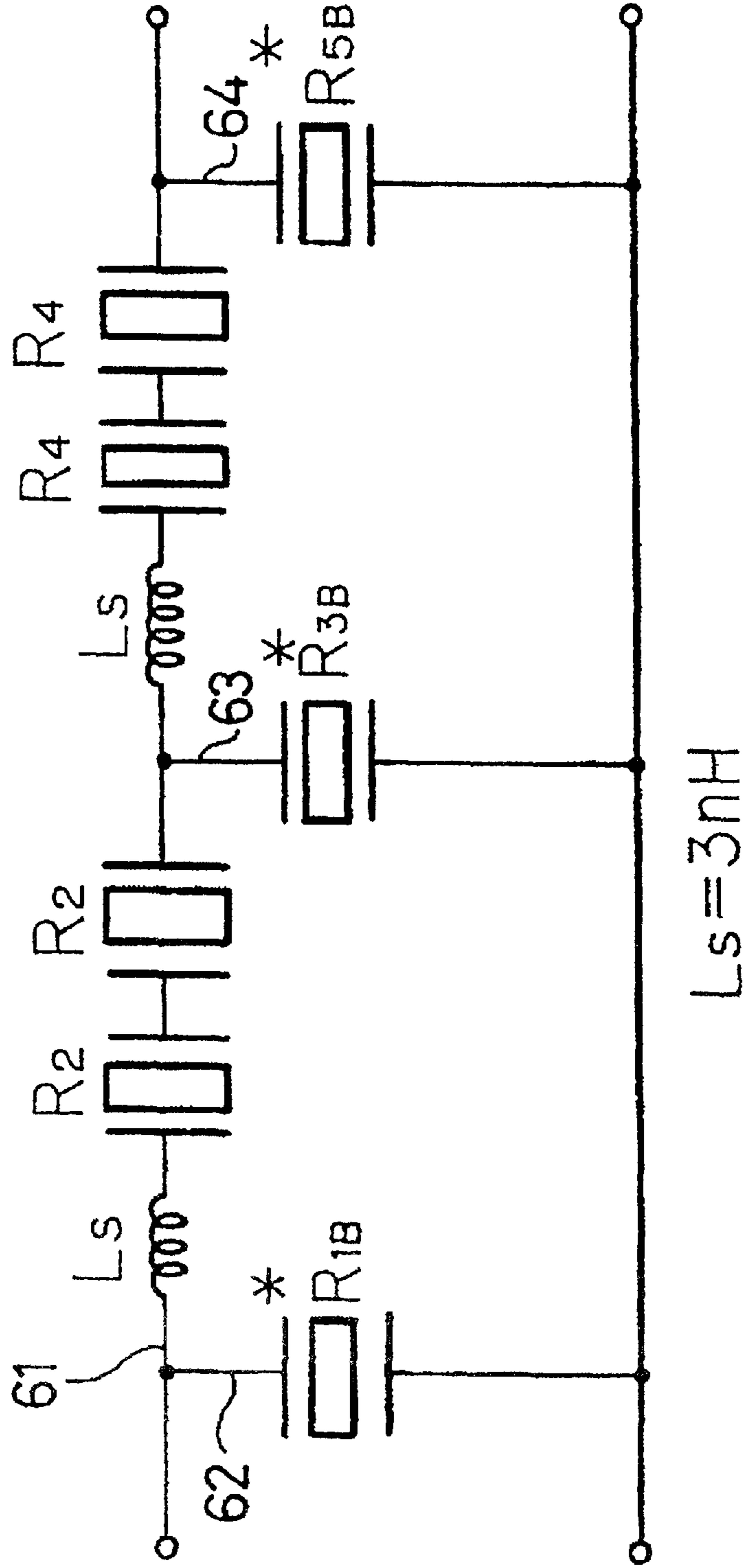

FIG. 35

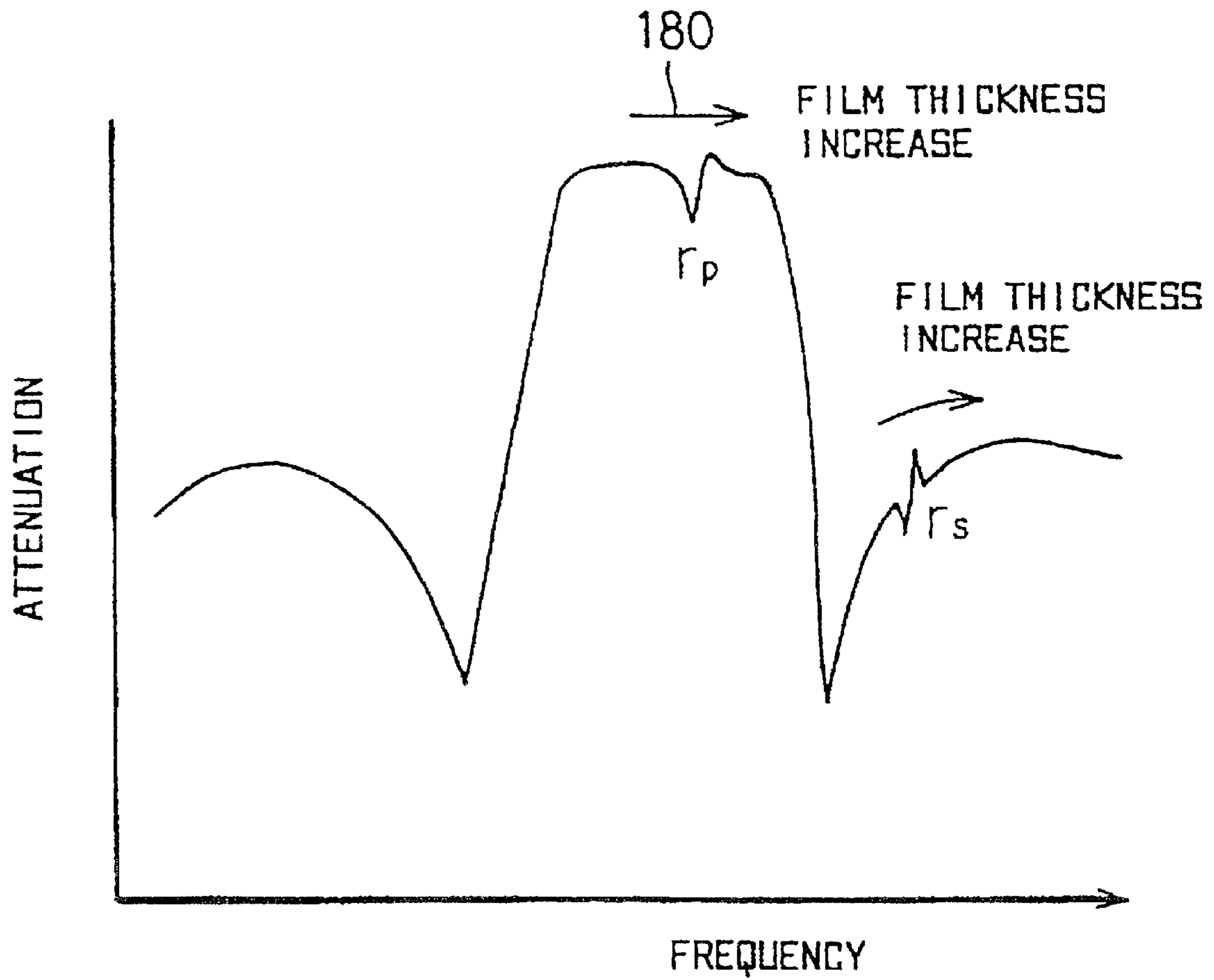

FIG. 36

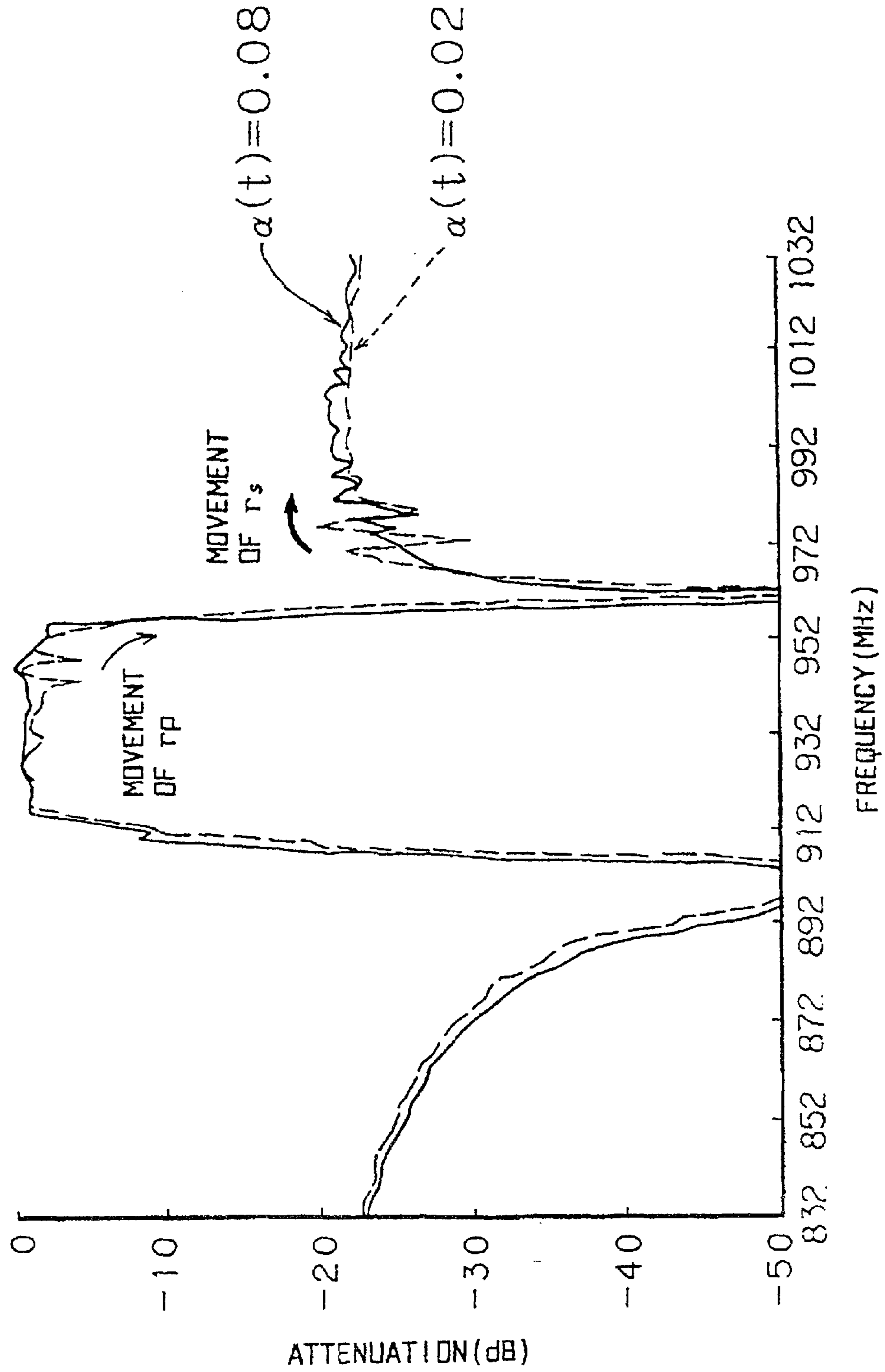

FIG.37A

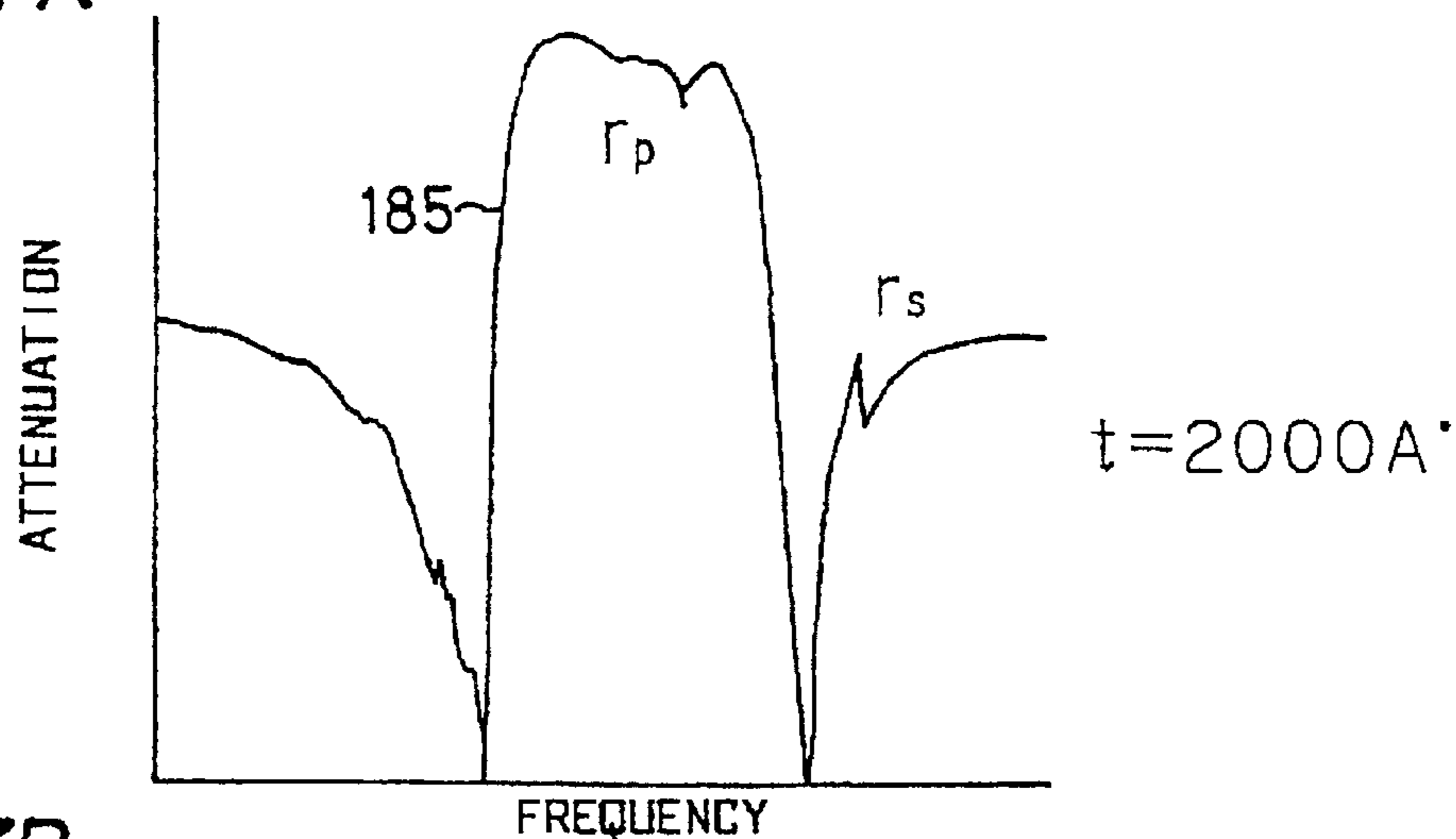

FIG.37B

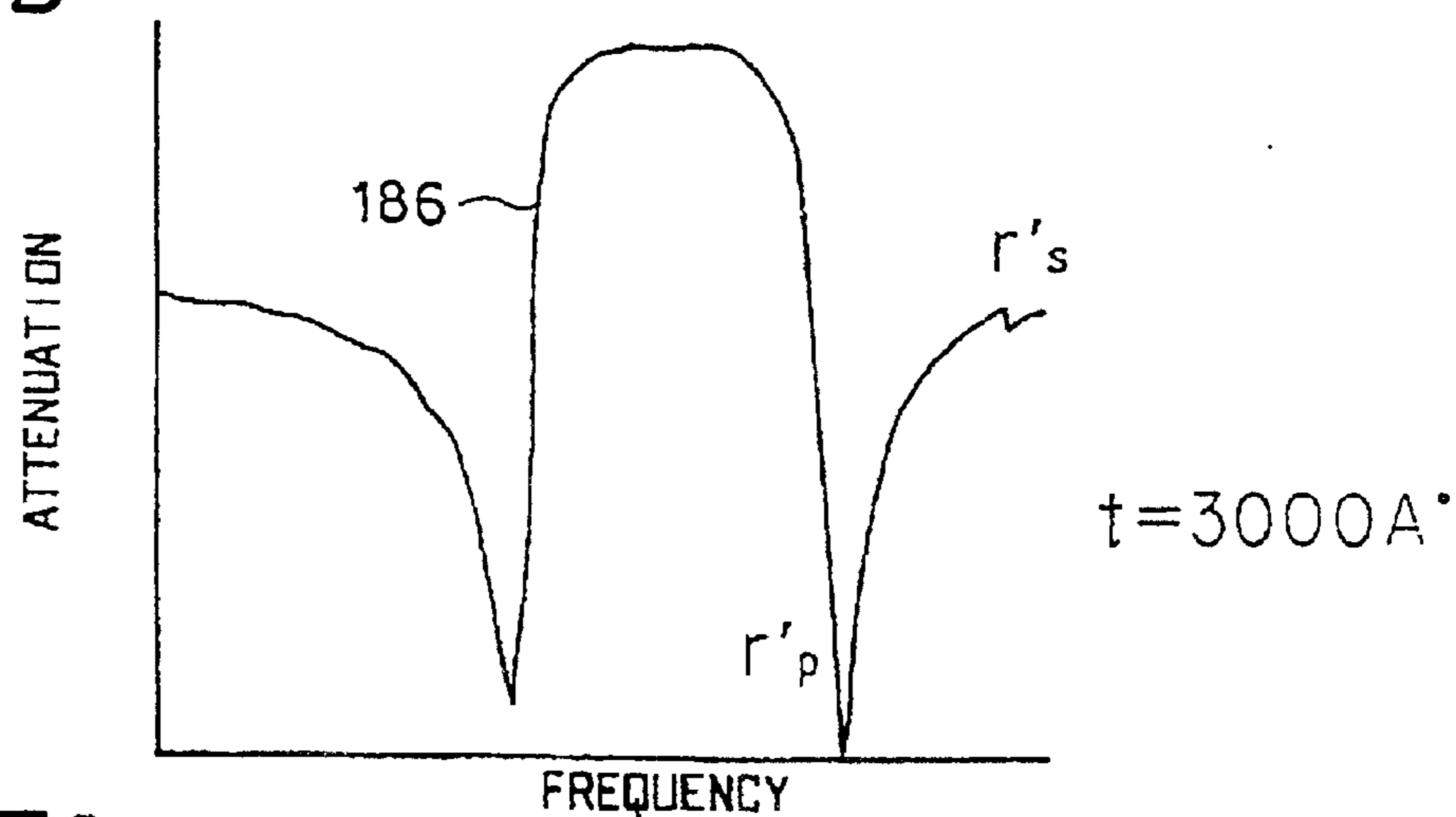

FIG.37C

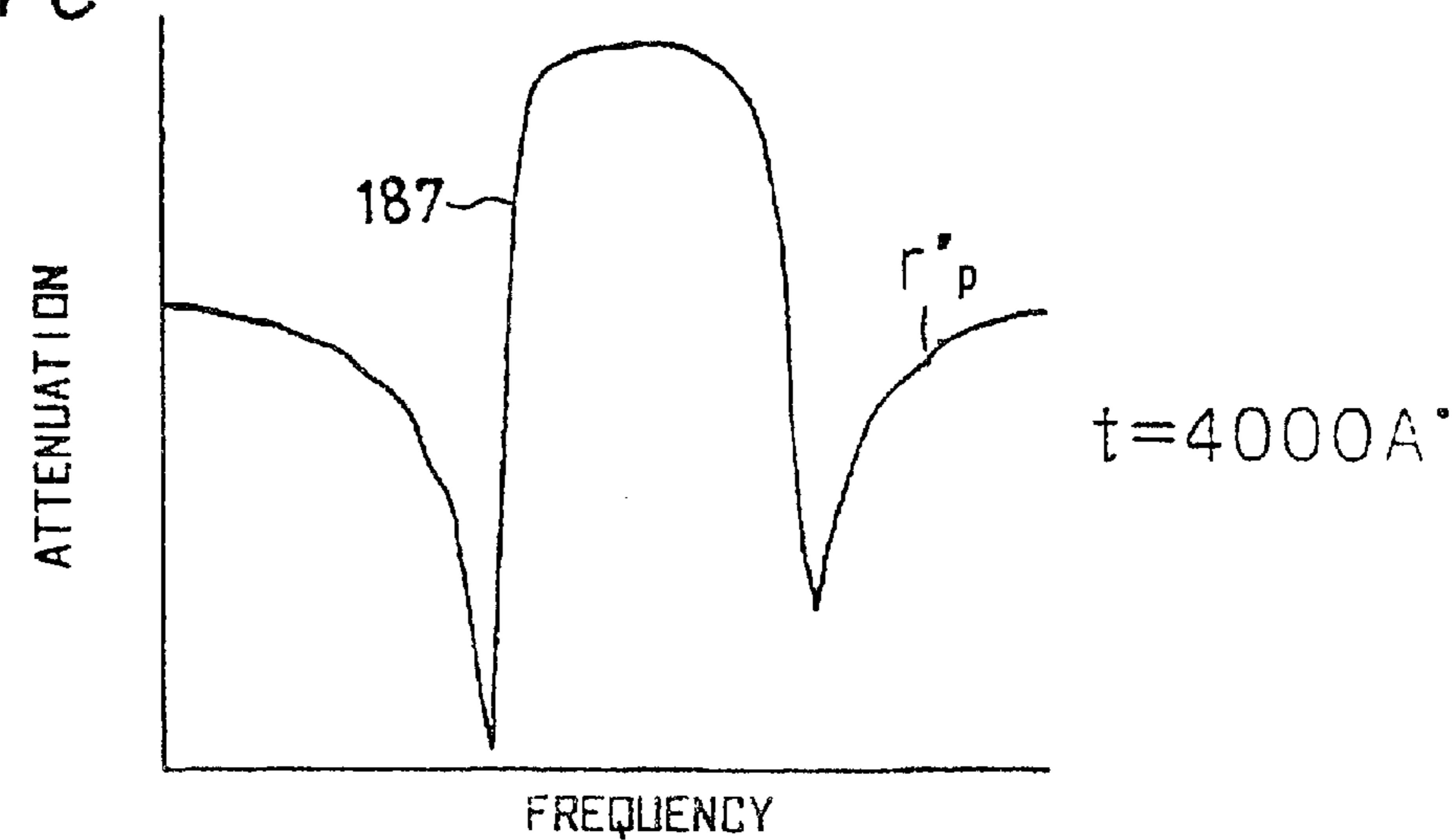

FIG. 38A

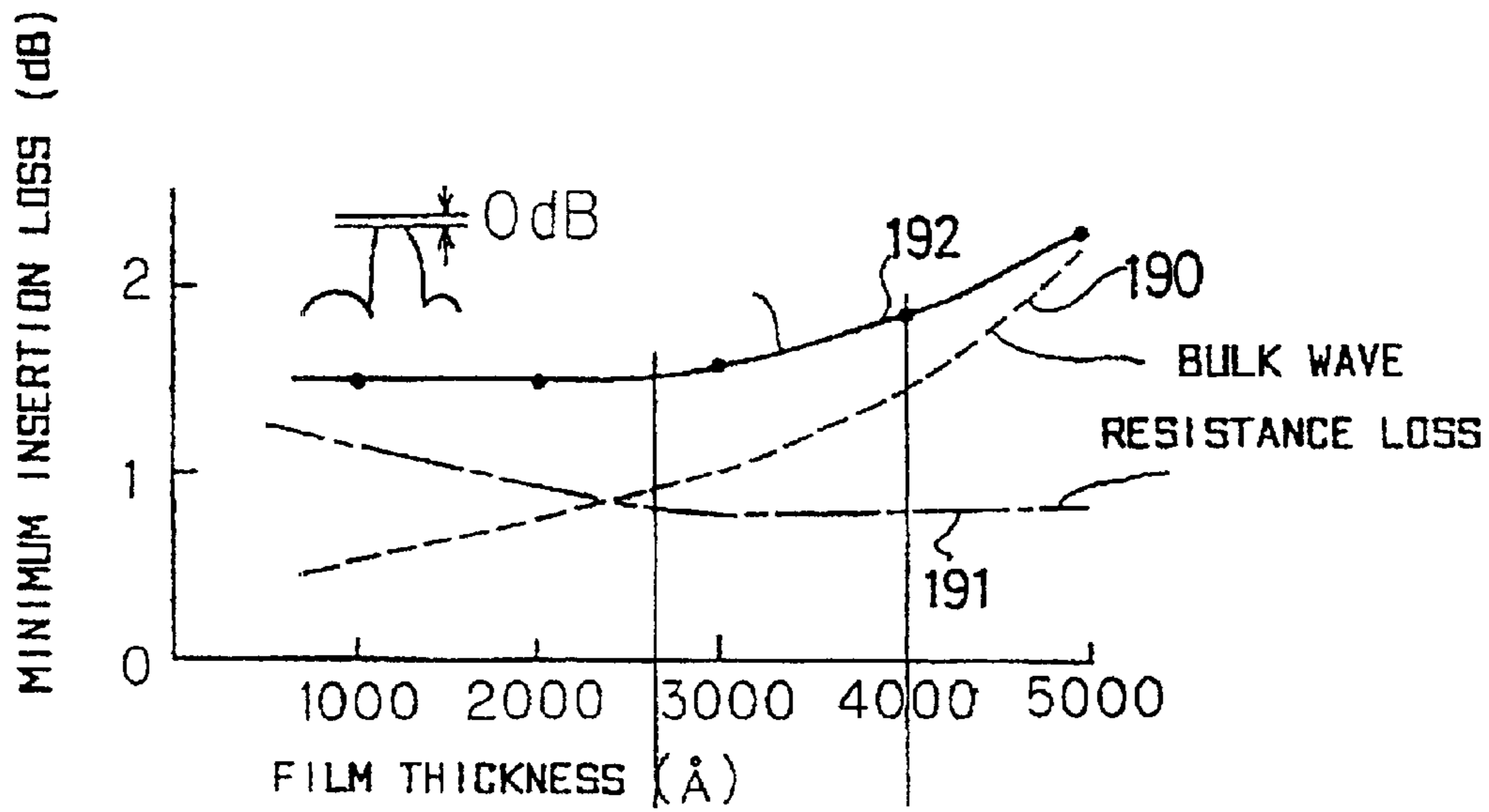

FIG. 38B

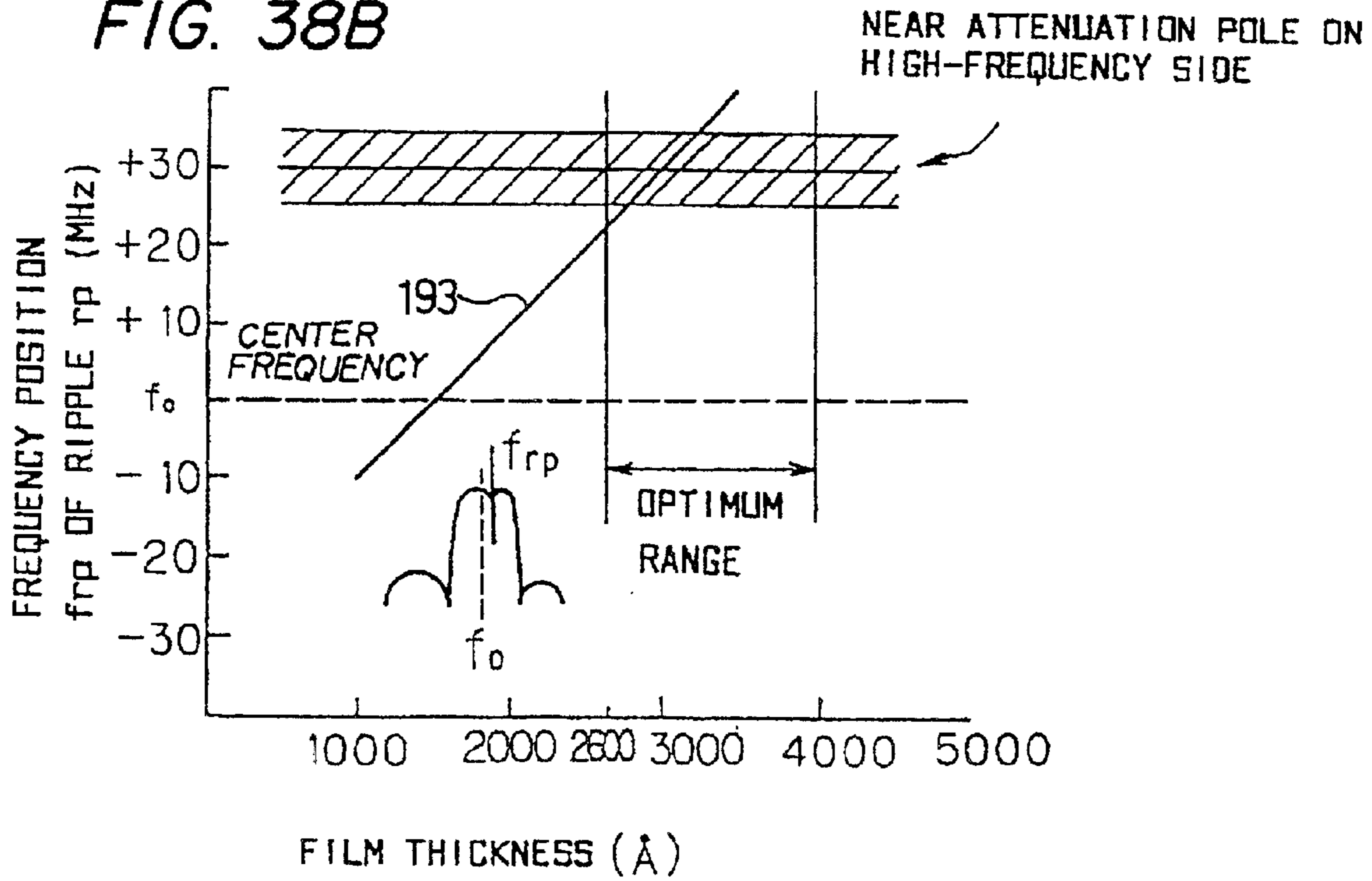

FIG. 39

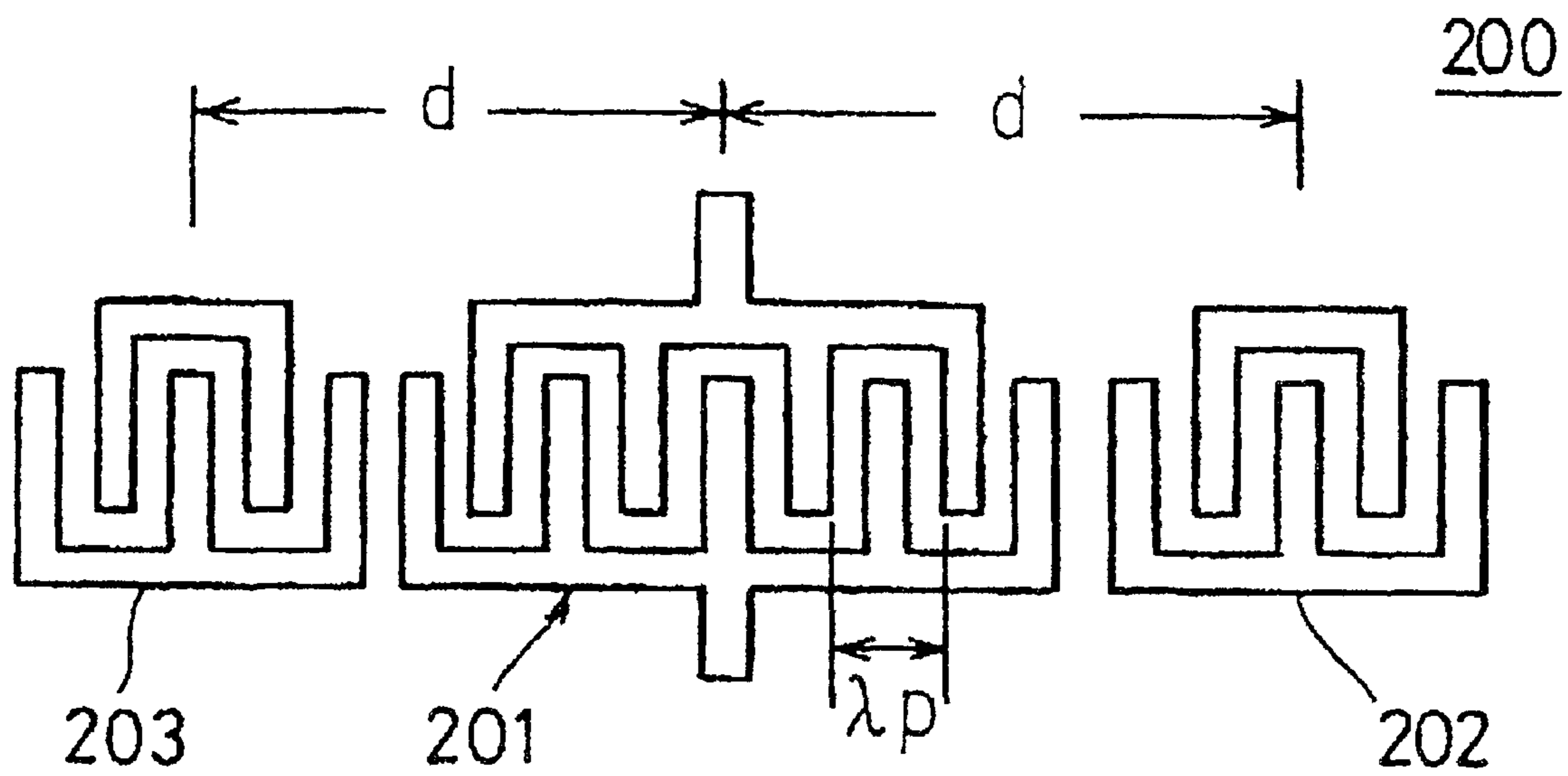

FIG. 40

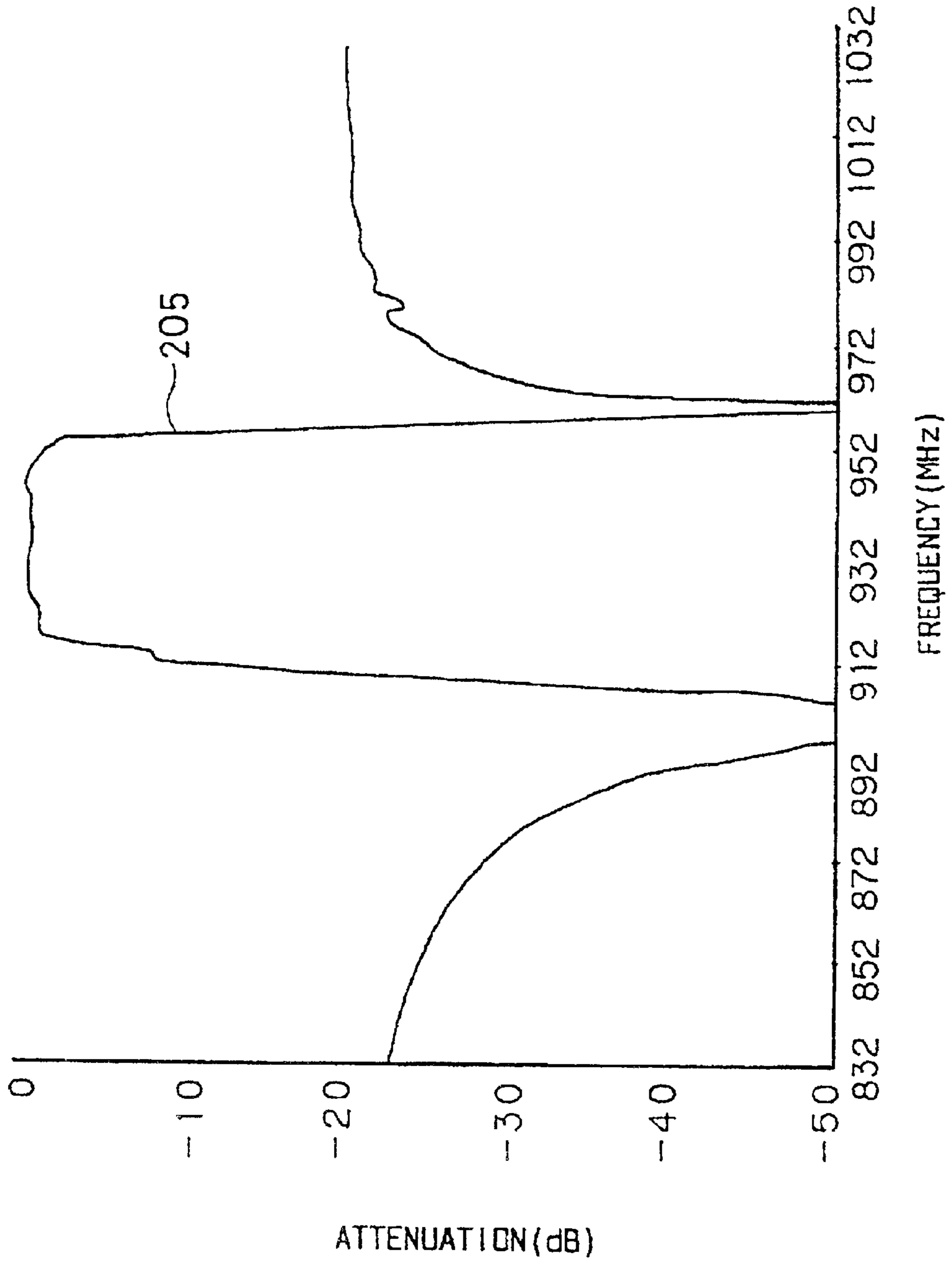

FIG. 41

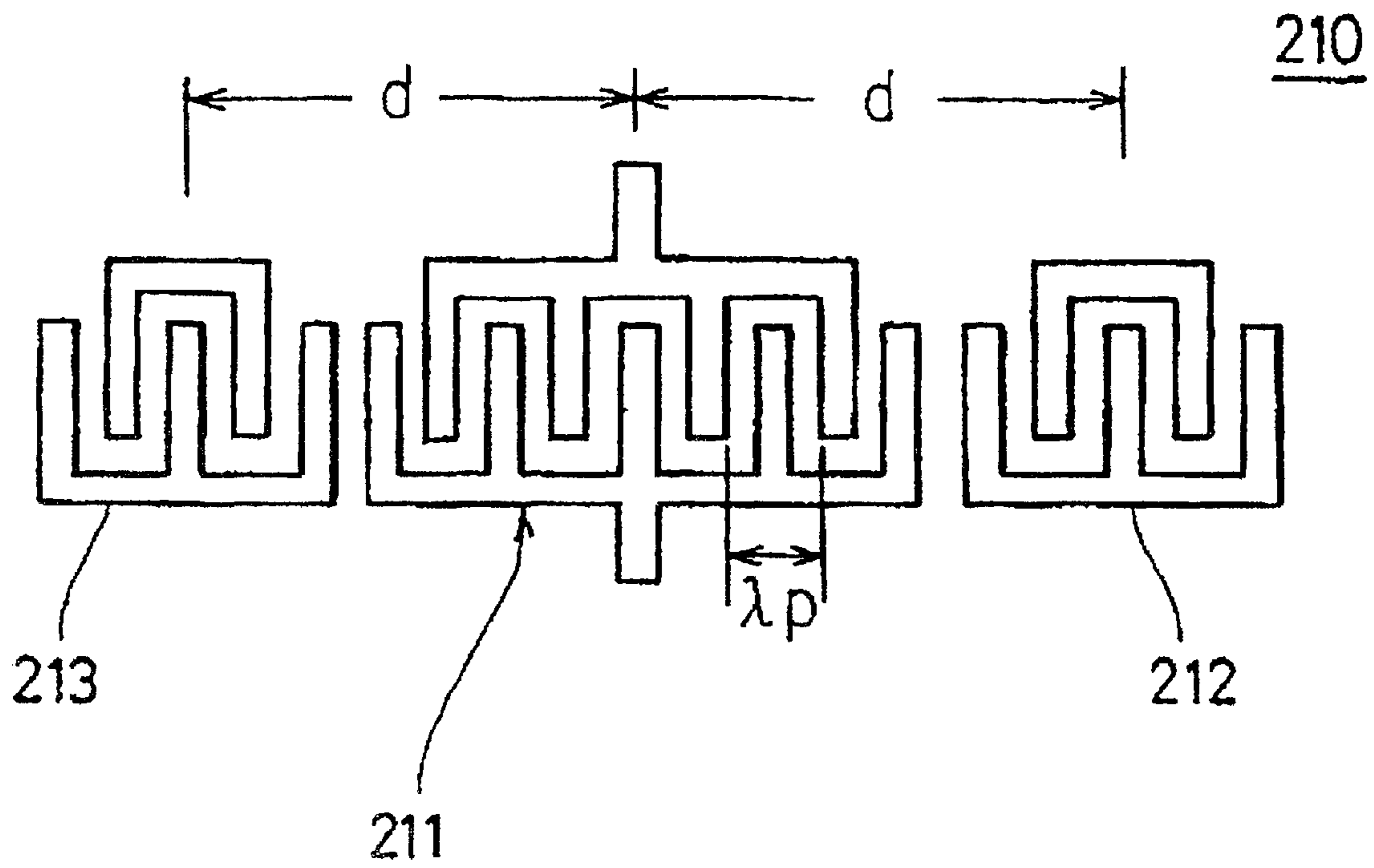

FIG. 42

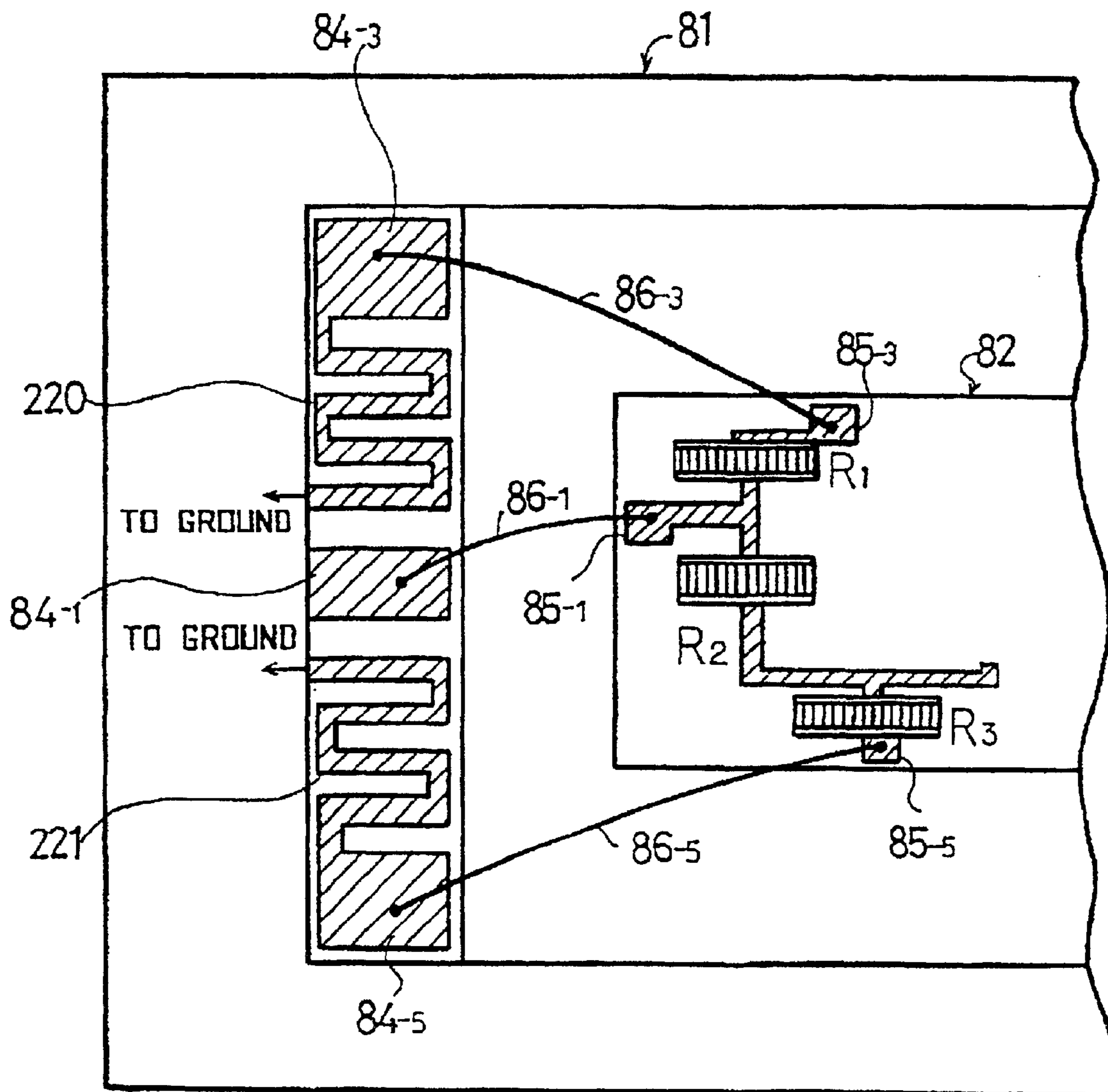

FIG. 43

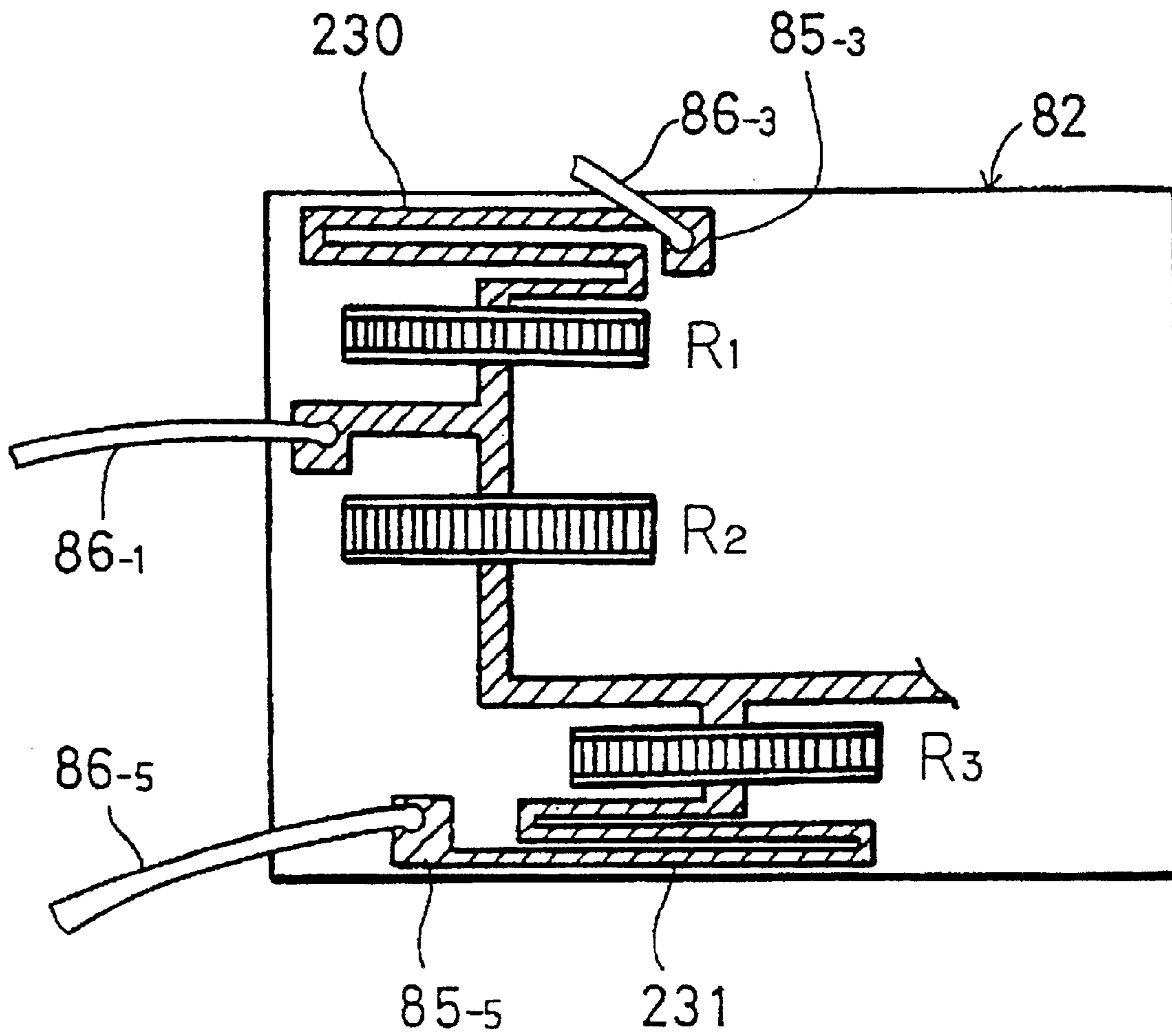
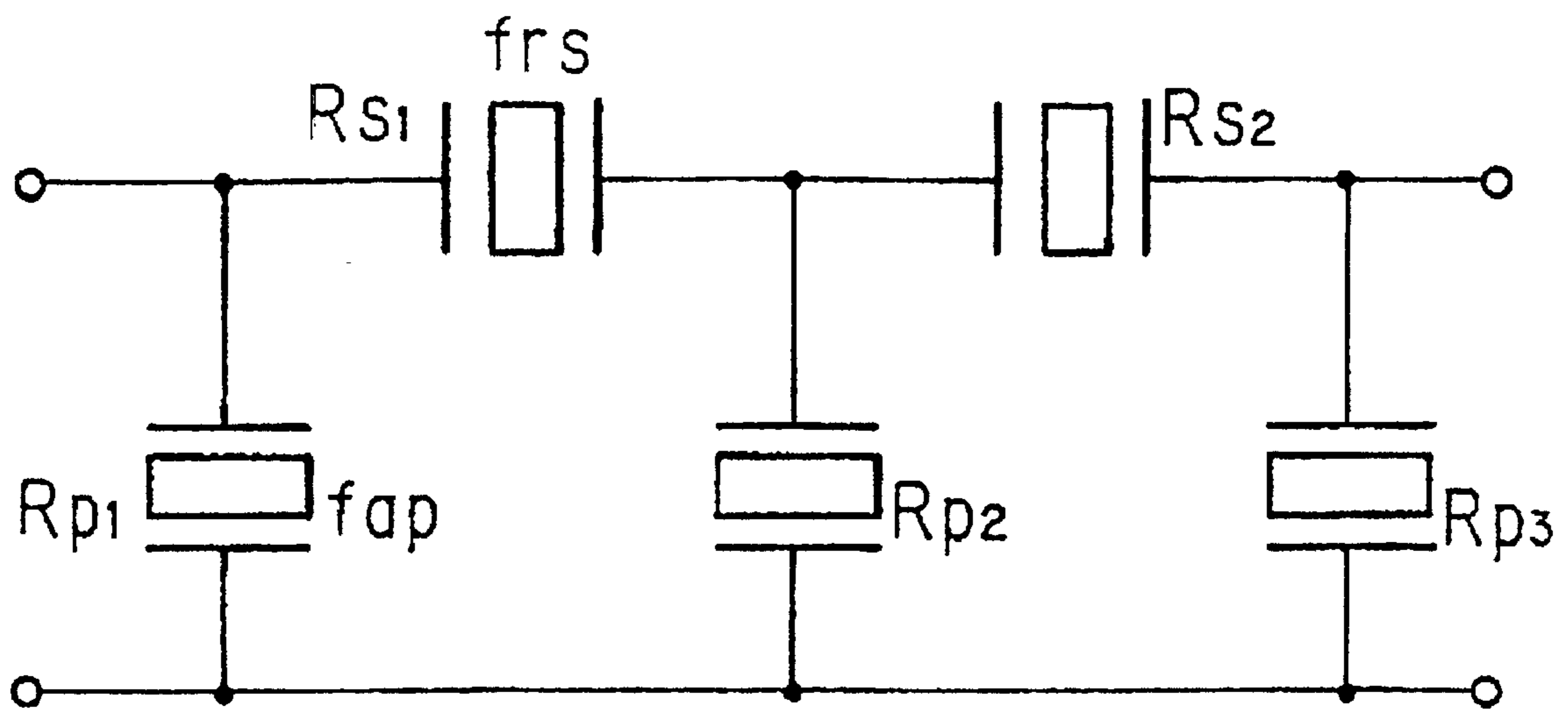

FIG. 44

240



$$frs > fap$$

$$frs - fap = 19\text{MHz}$$

FIG. 45

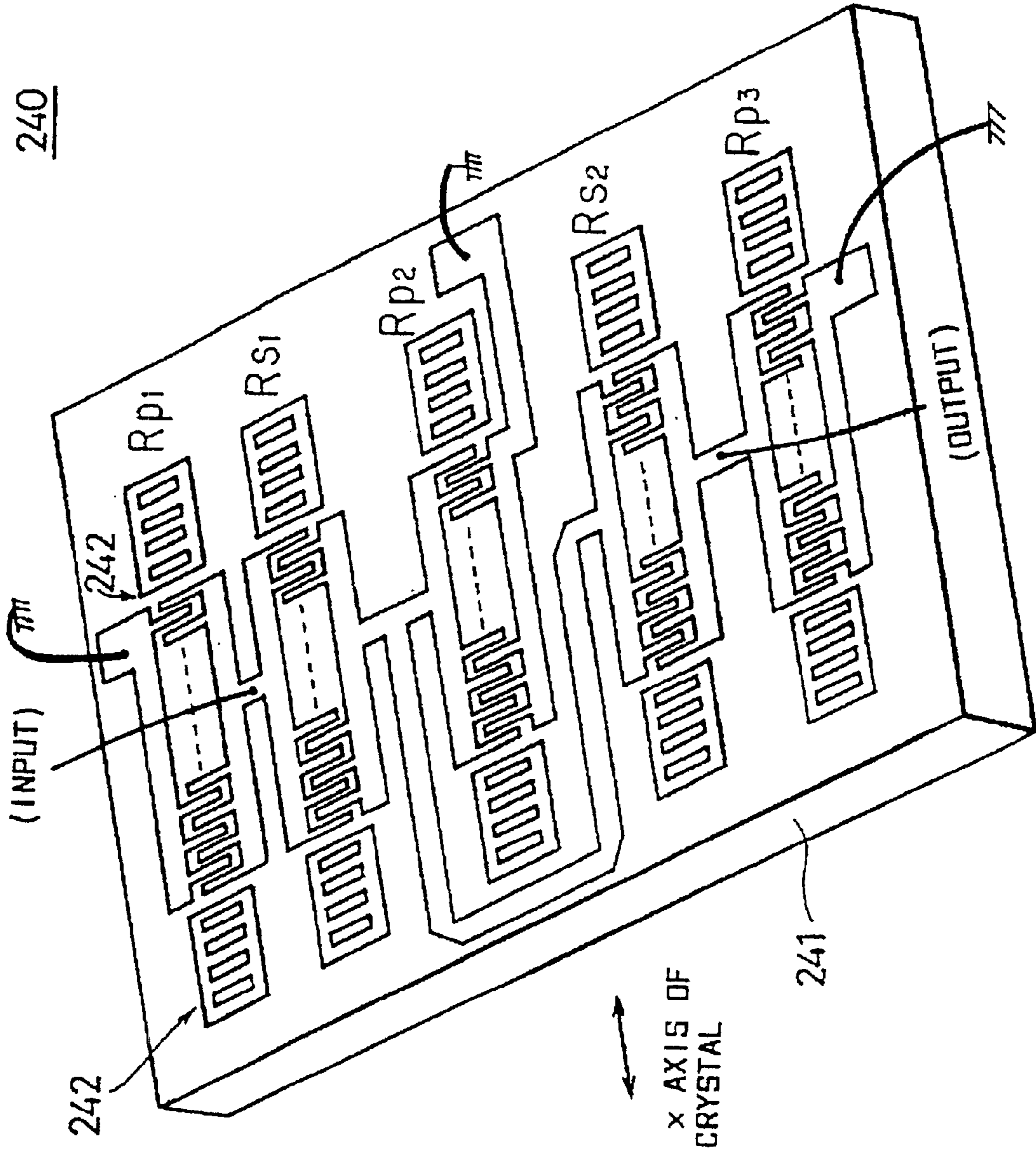

FIG. 46A

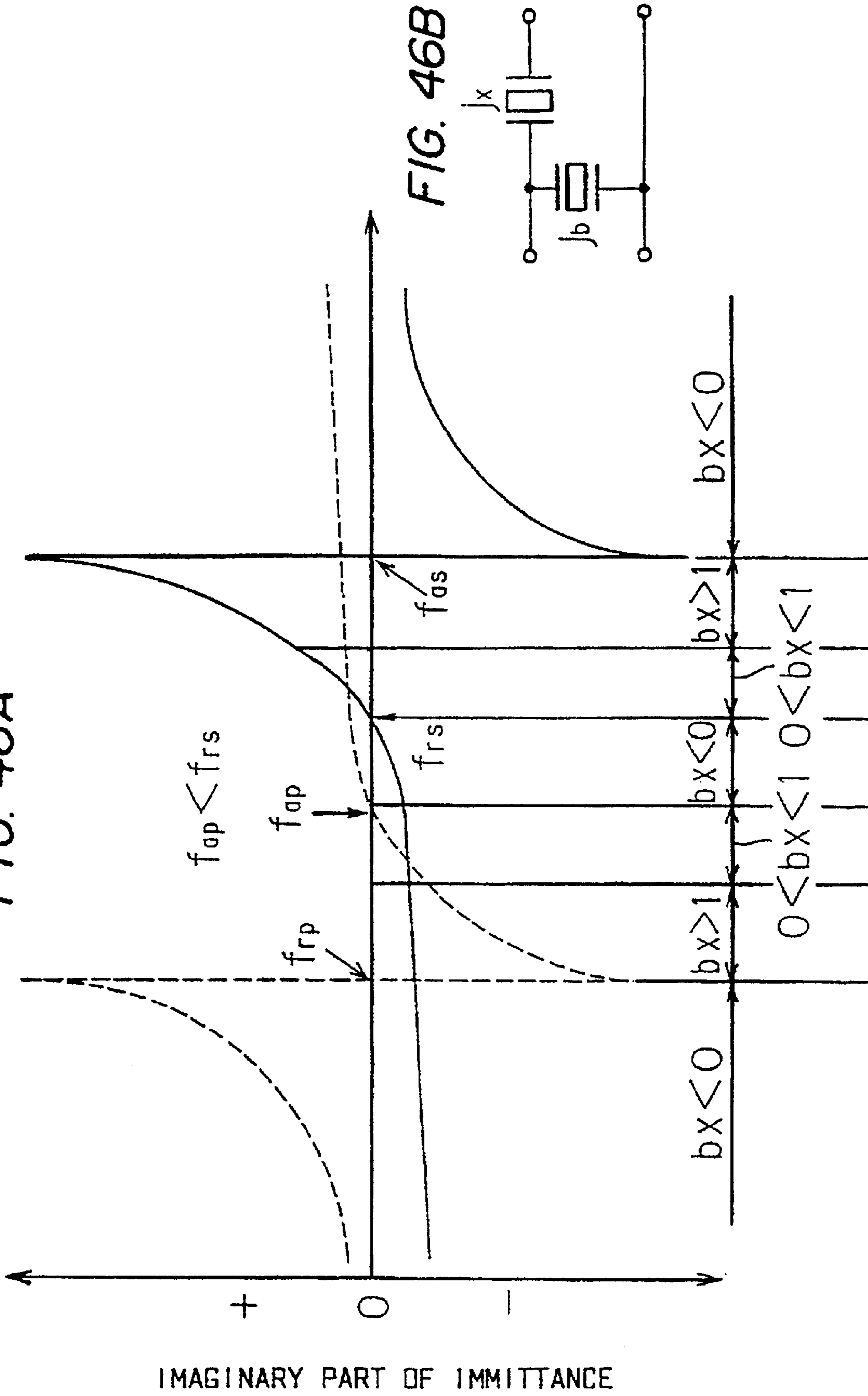
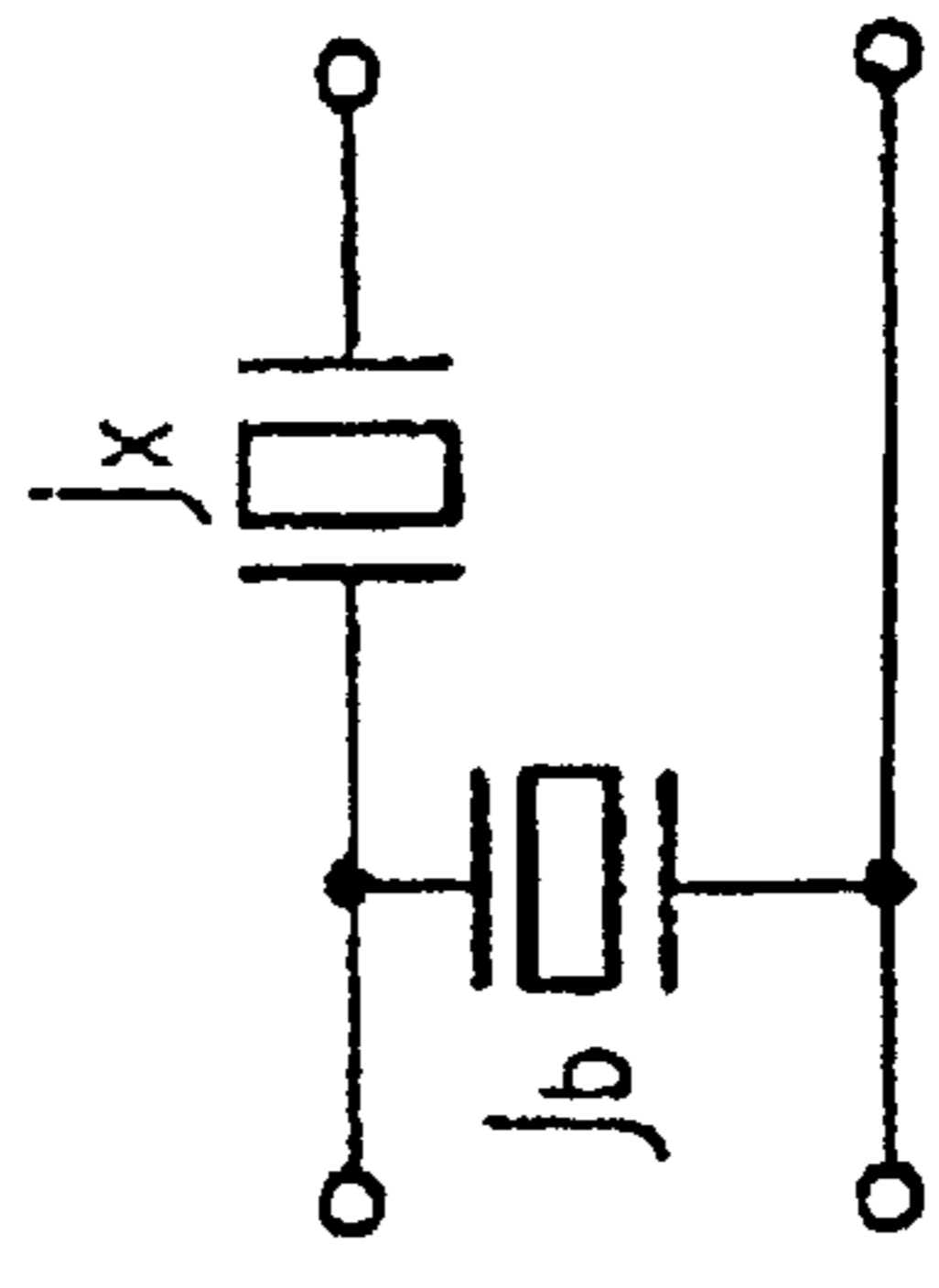

FIG. 46B



IMAGINARY PART OF IMMITTANCE

FIG. 47A

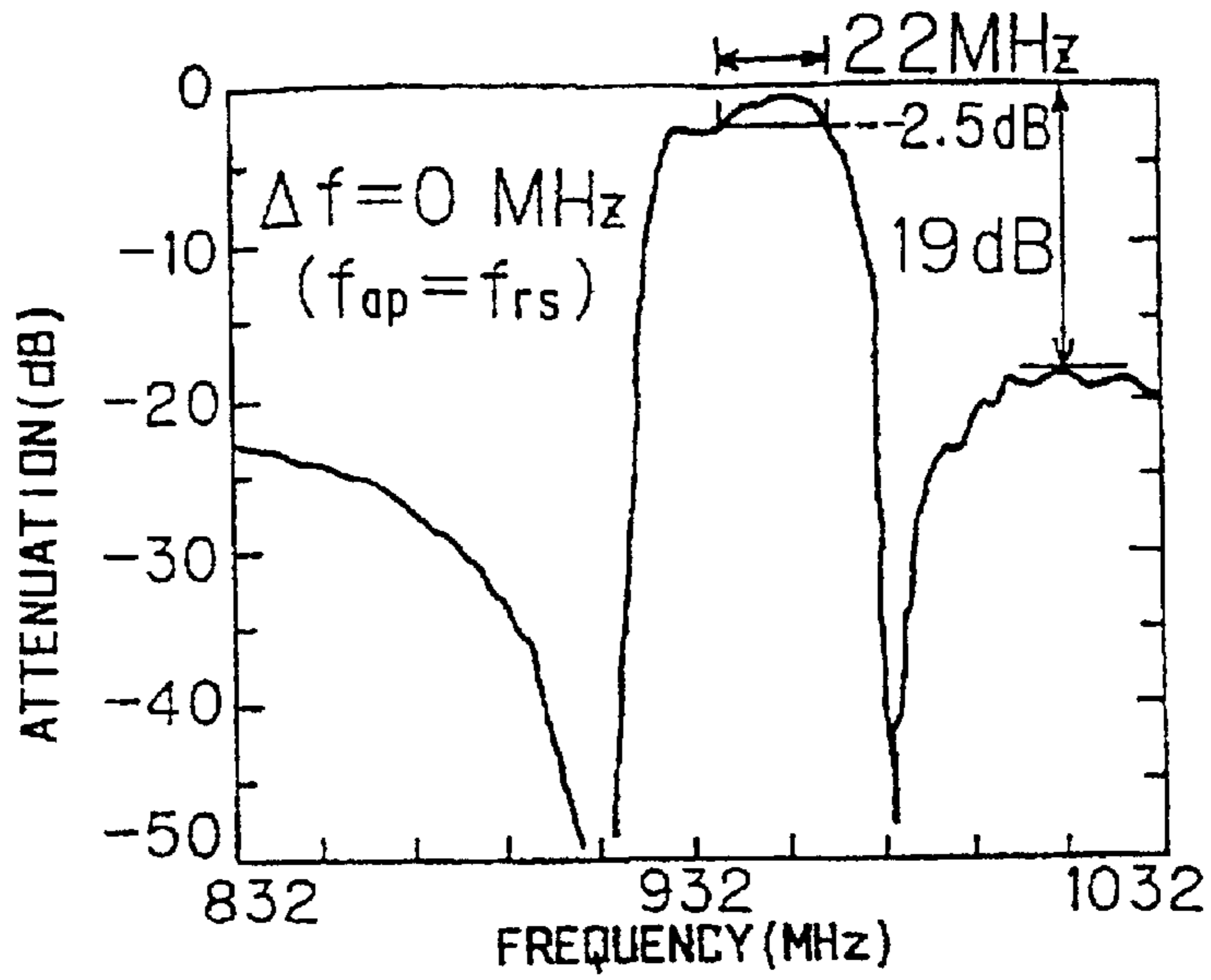

FIG. 47B

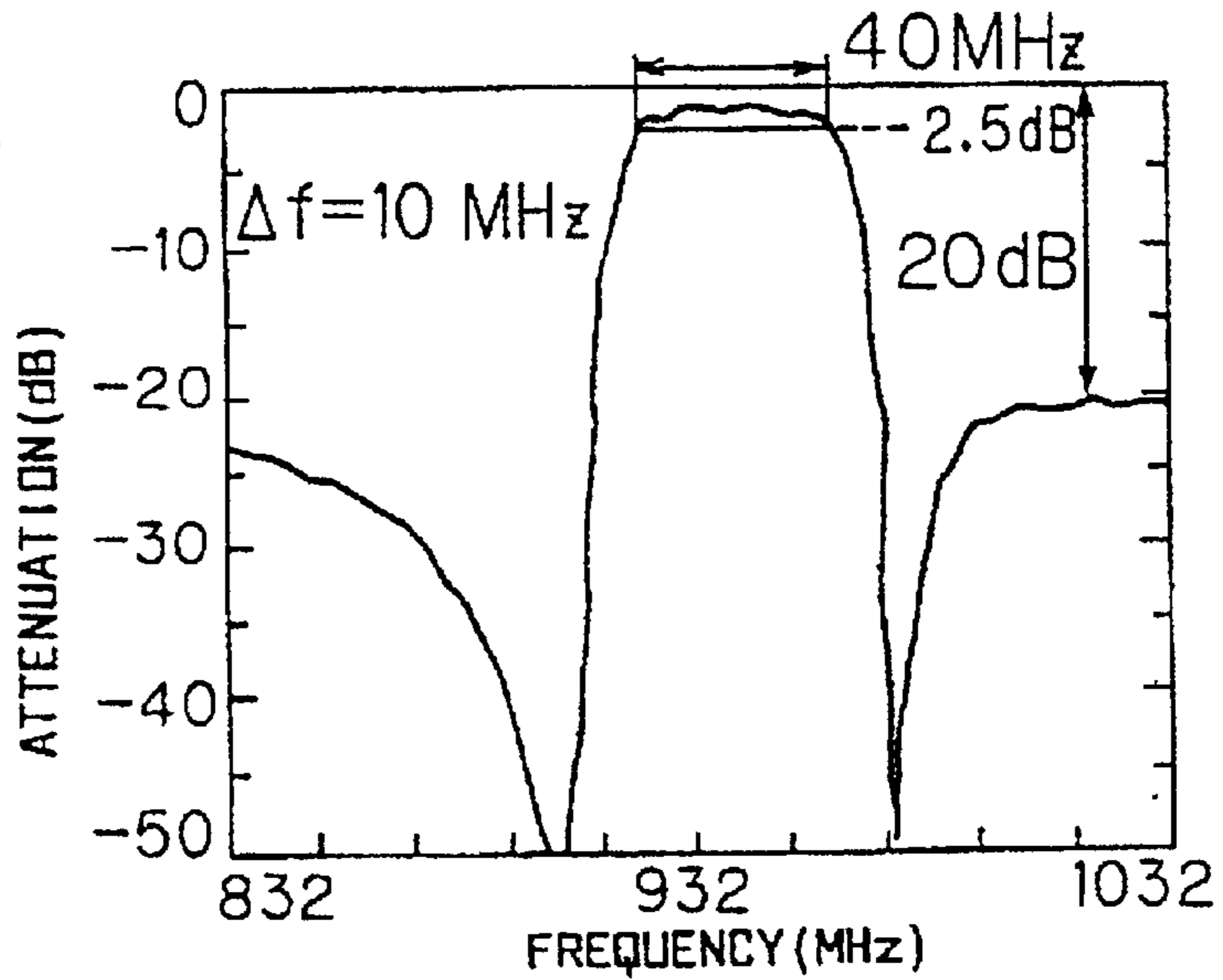

FIG. 47C

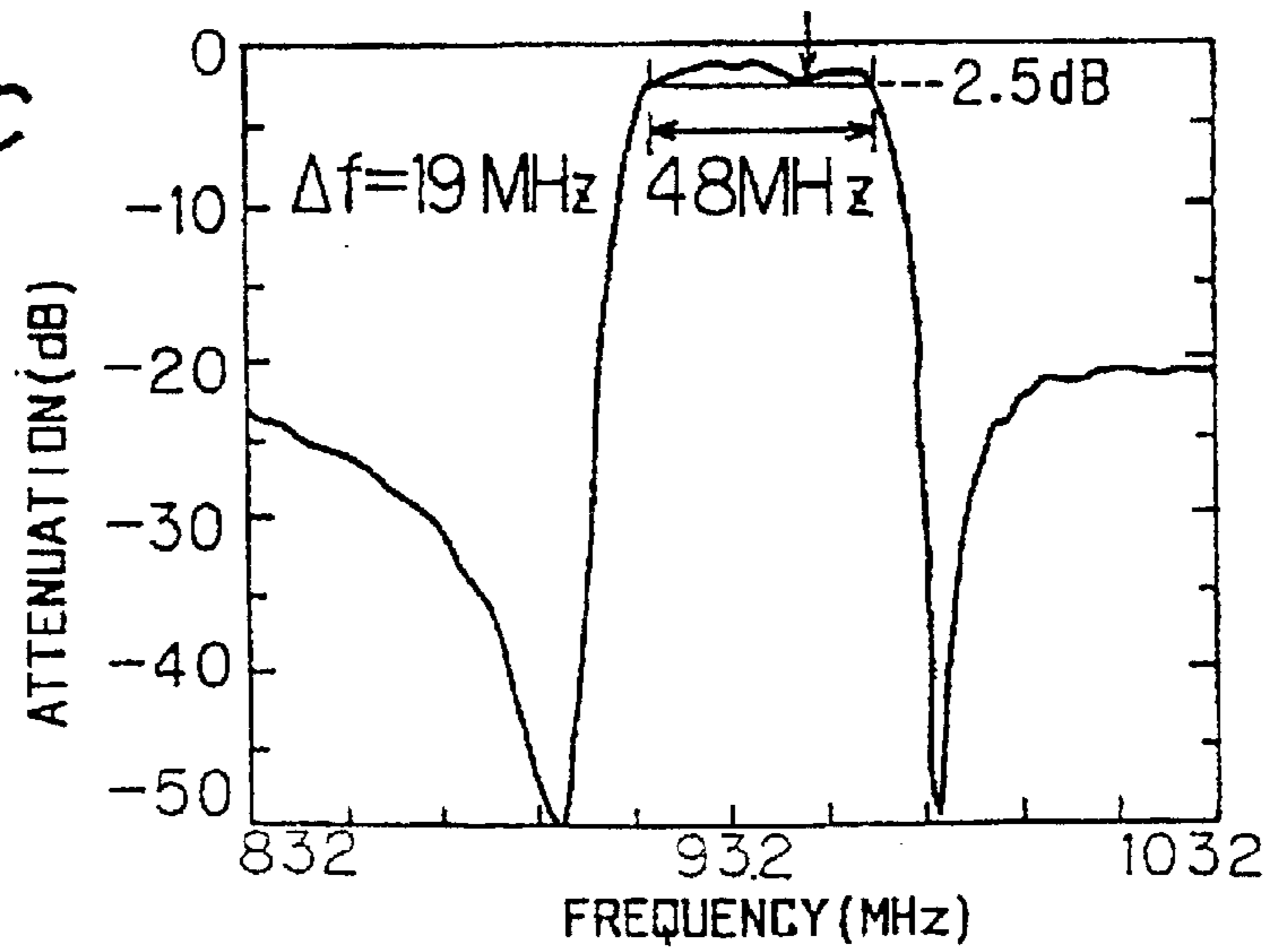
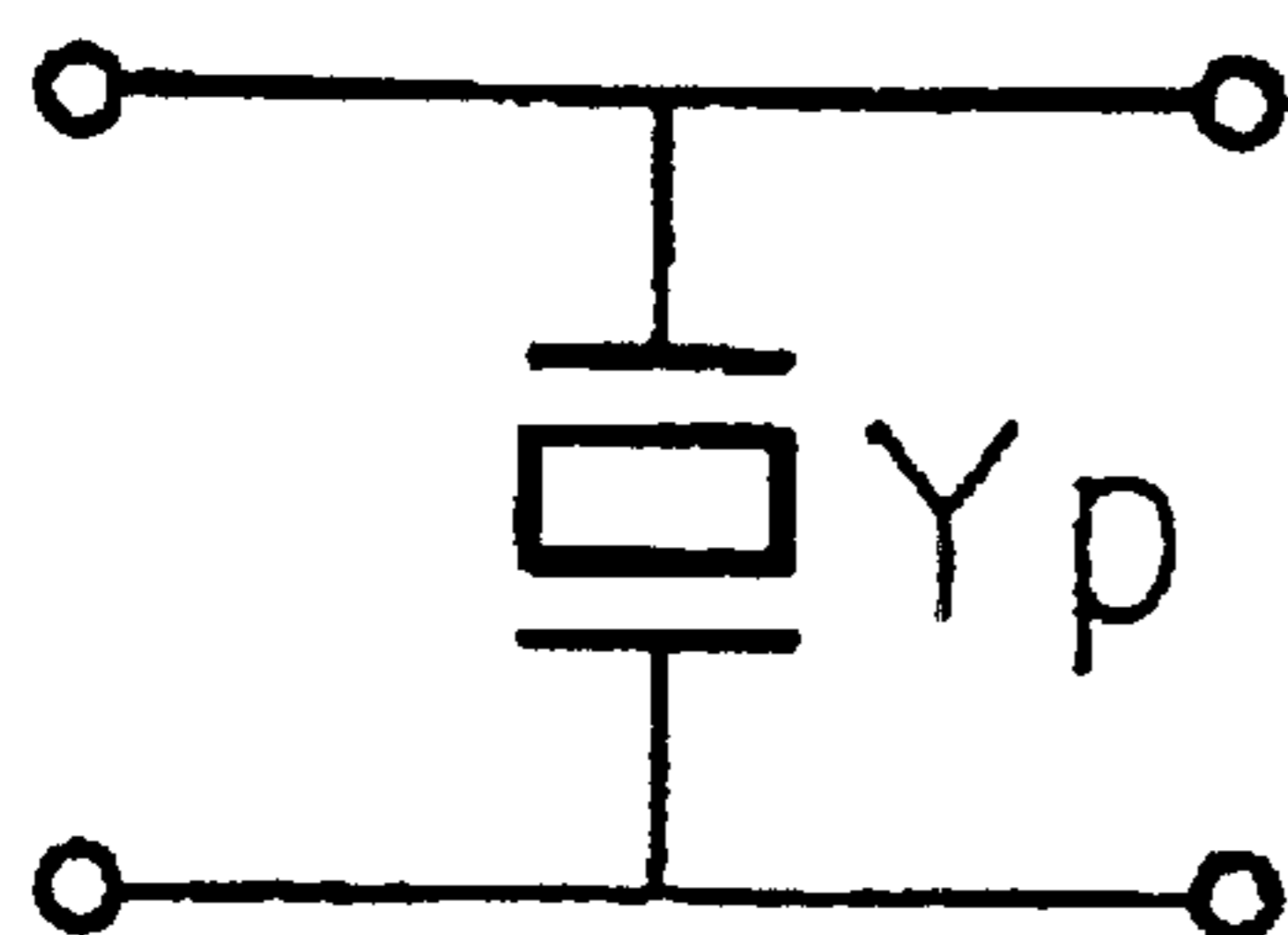

FIG. 48A

ATTENUATION



$$Y_p = \frac{1}{25} \left(\frac{1 - S_{21}}{S_{21}} \right) (S)$$

FIG. 48B

IMPEDANCE

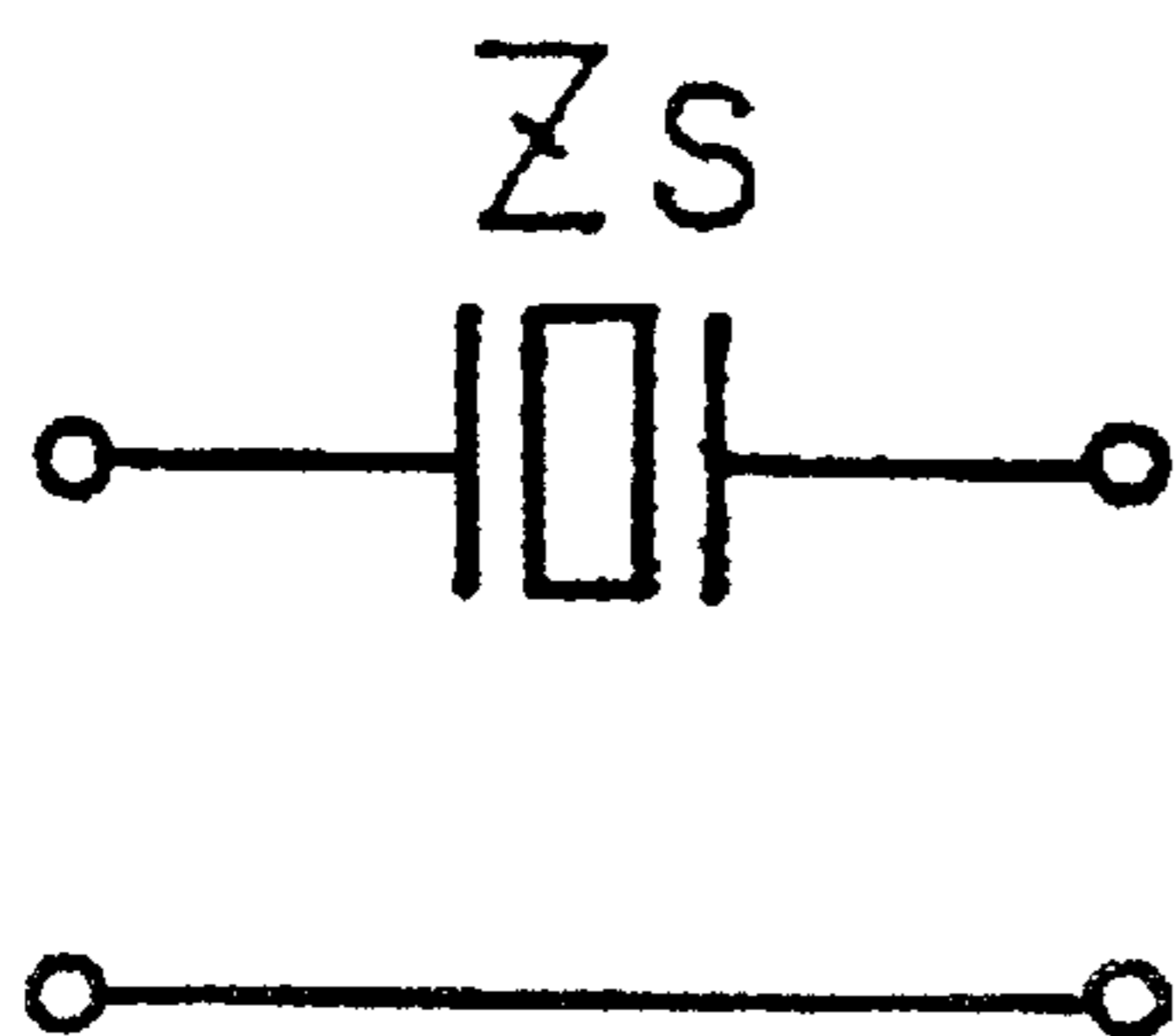

$$Z_s = 100 \left(\frac{1 - S_{21}}{S_{21}} \right) (\Omega)$$

FIG. 49

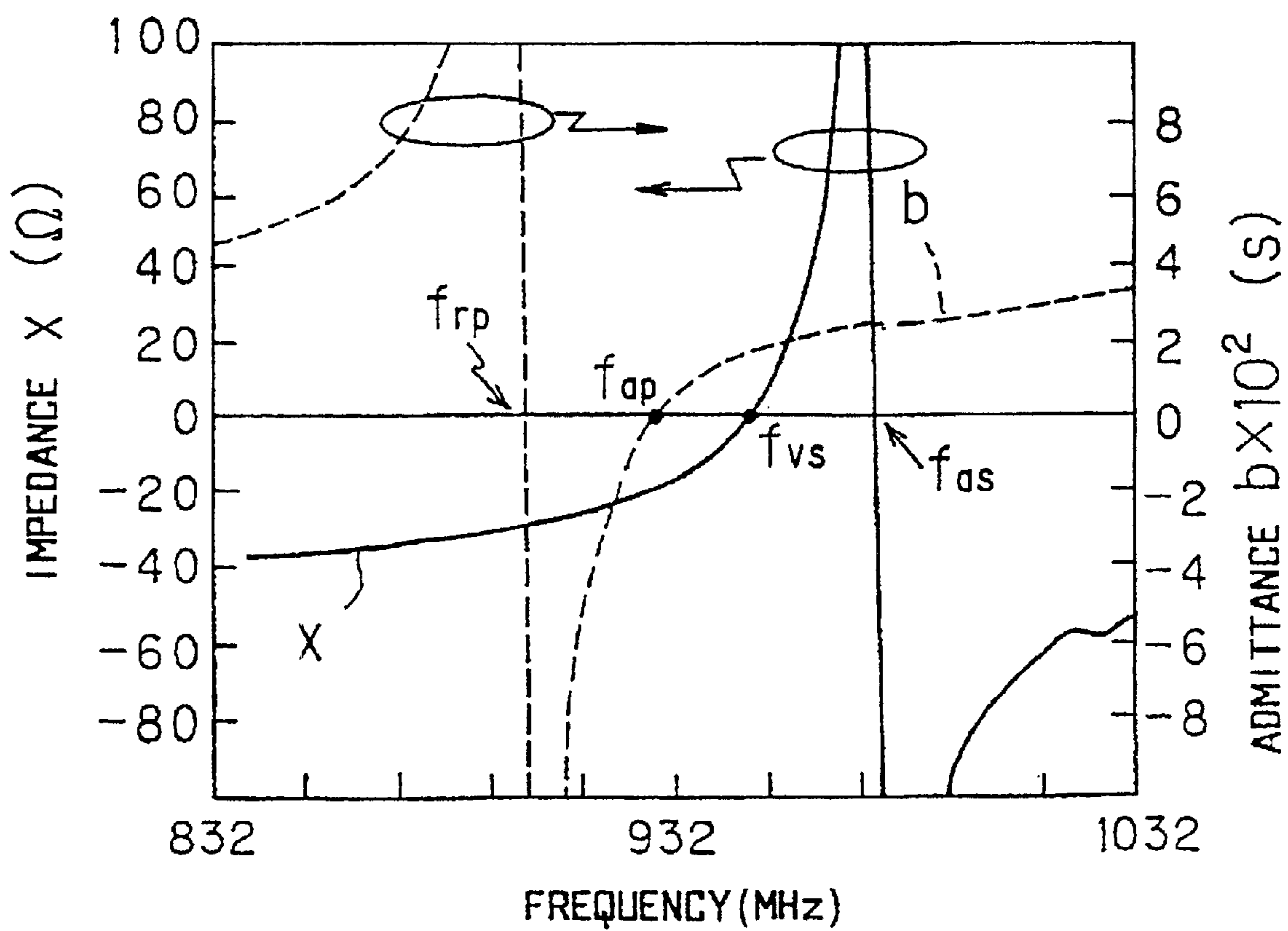

FIG. 50

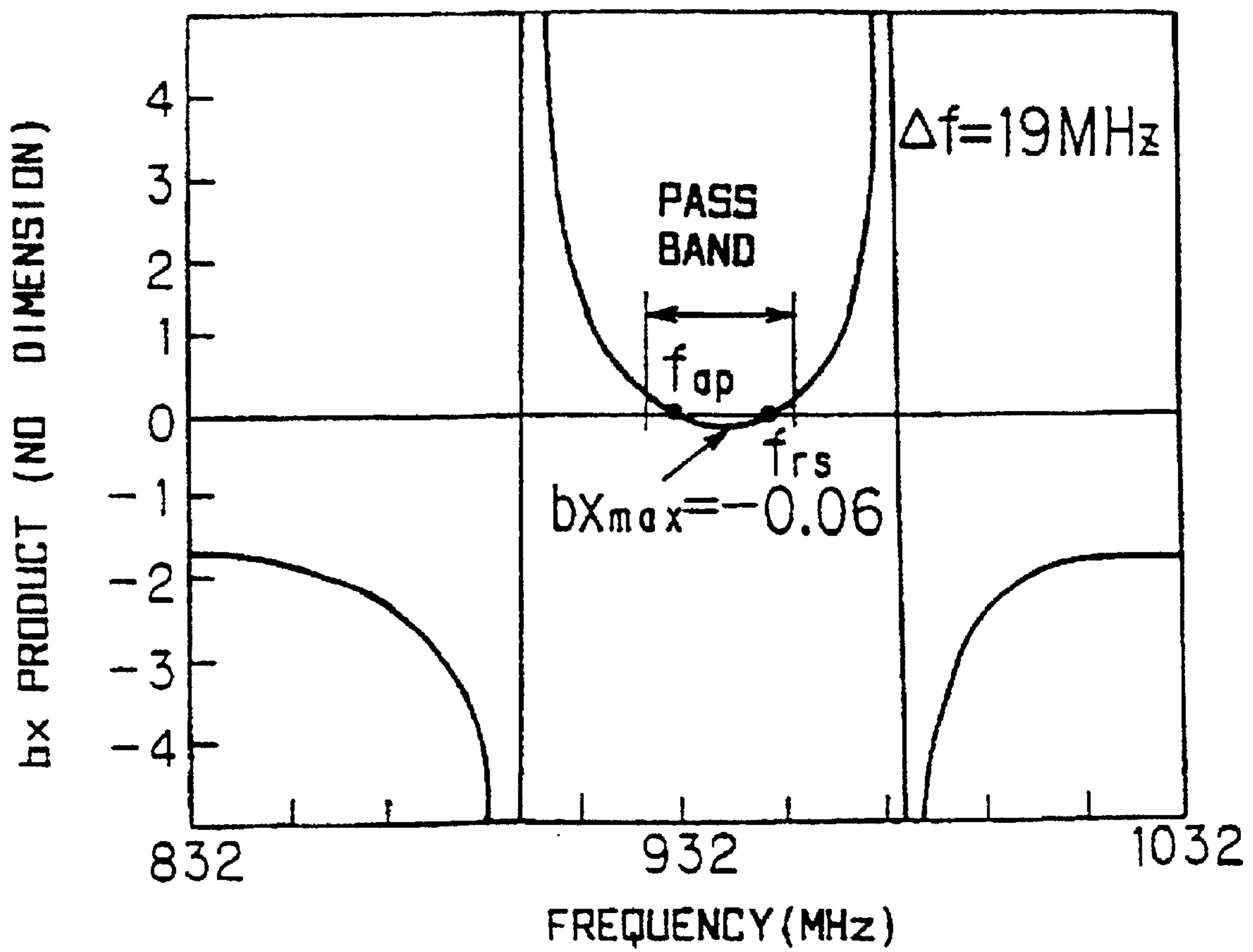

FIG. 51

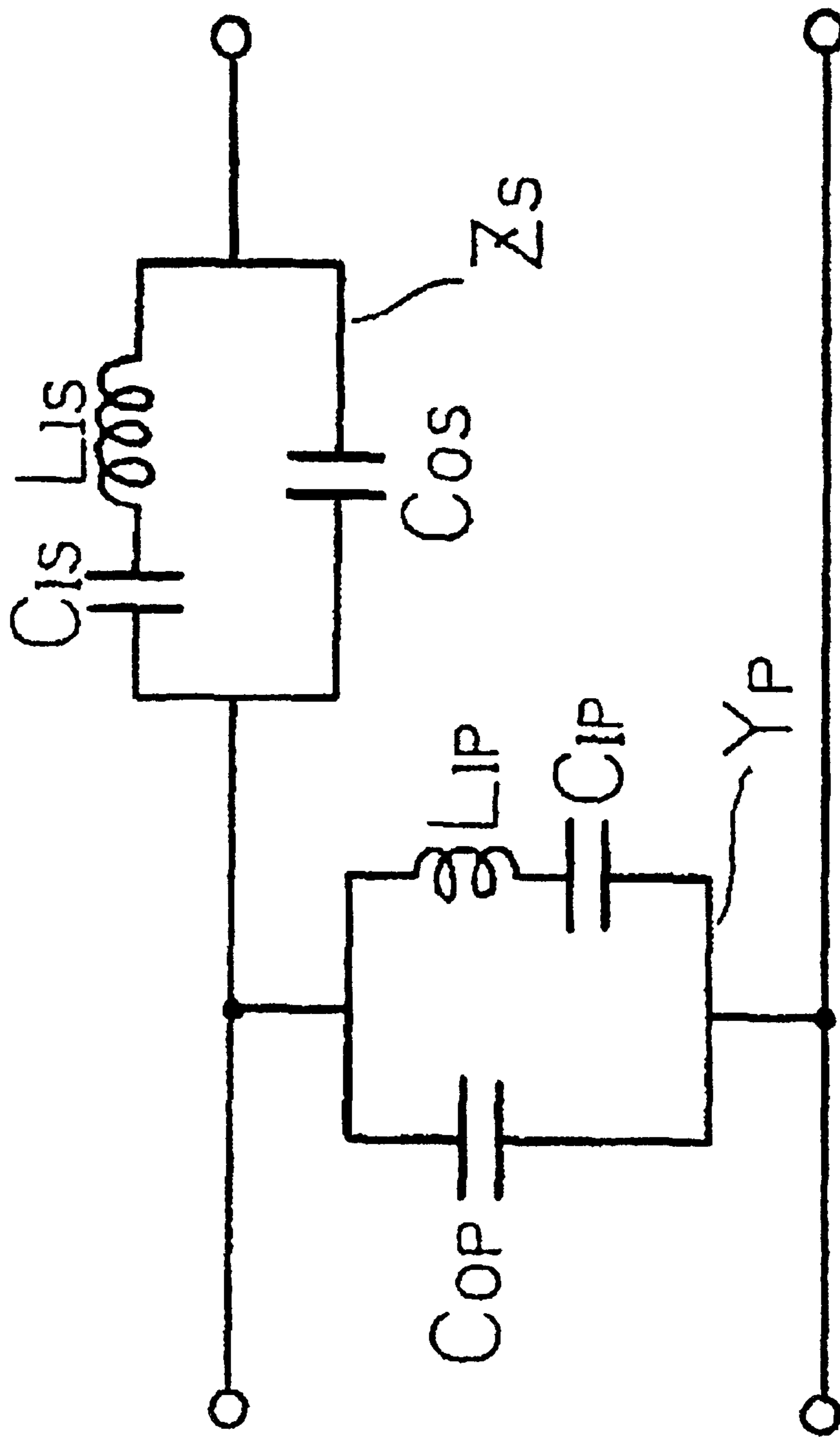

FIG. 52

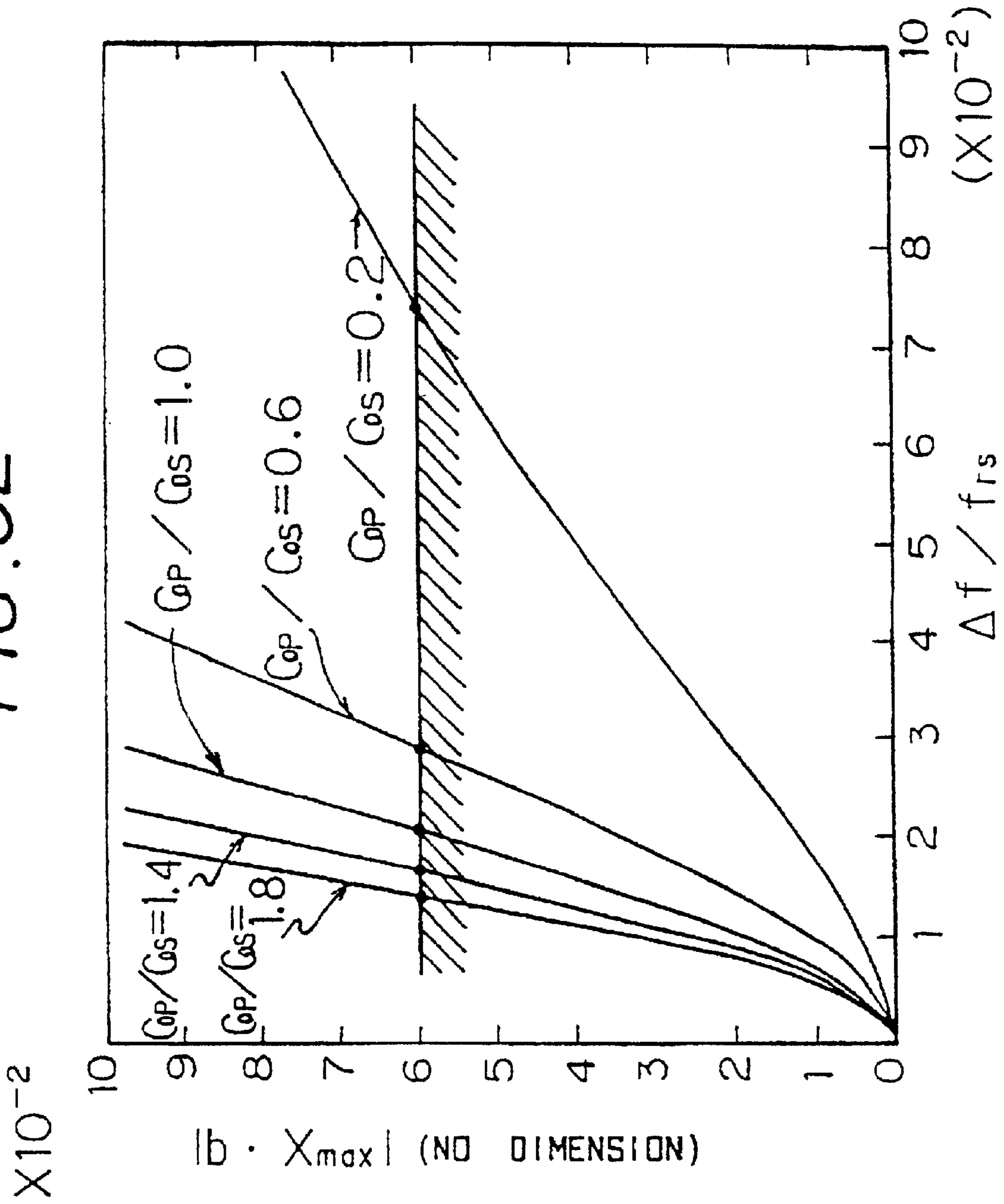

FIG. 53

(AMENDED)

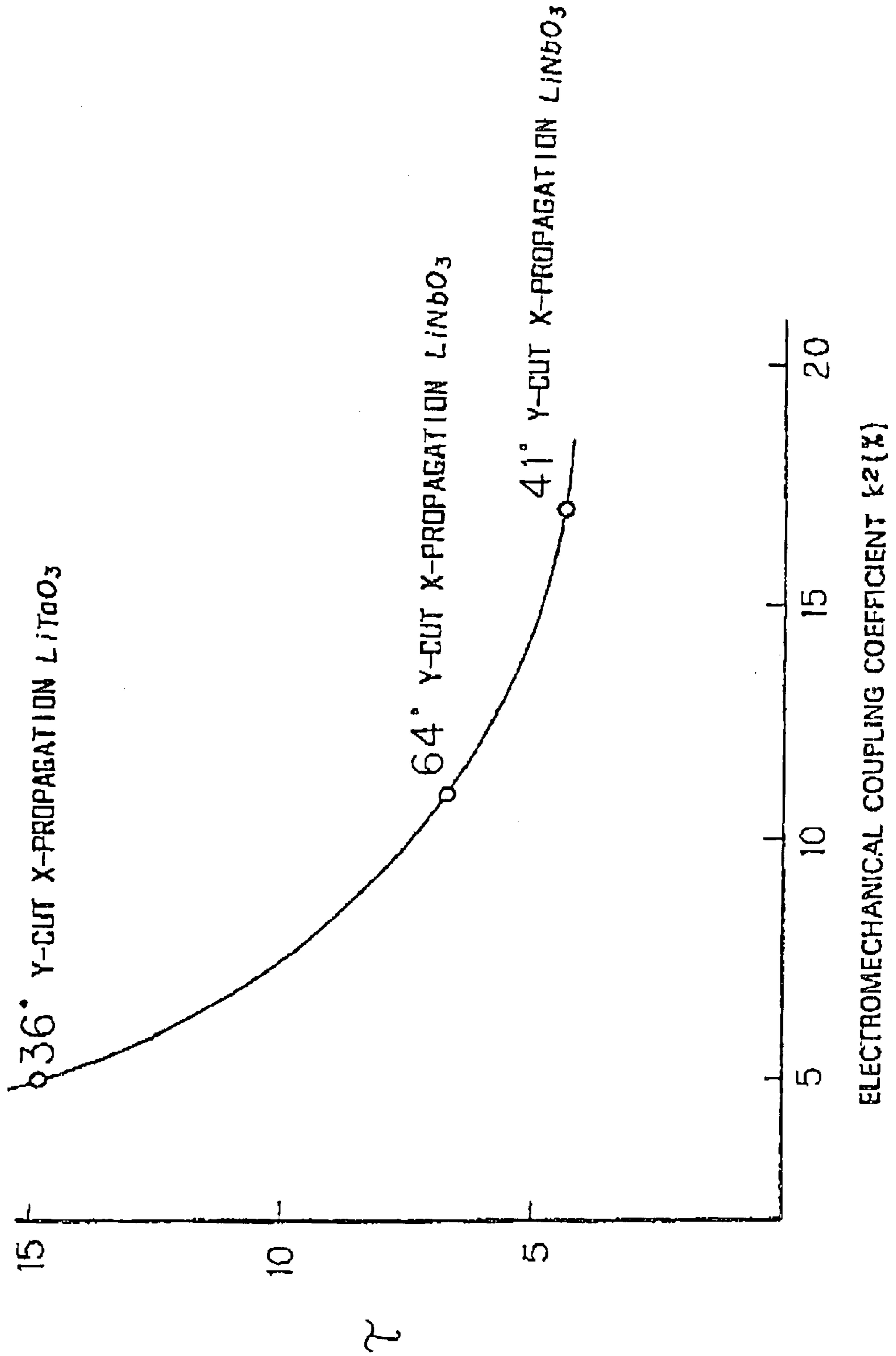

FIG. 54

250

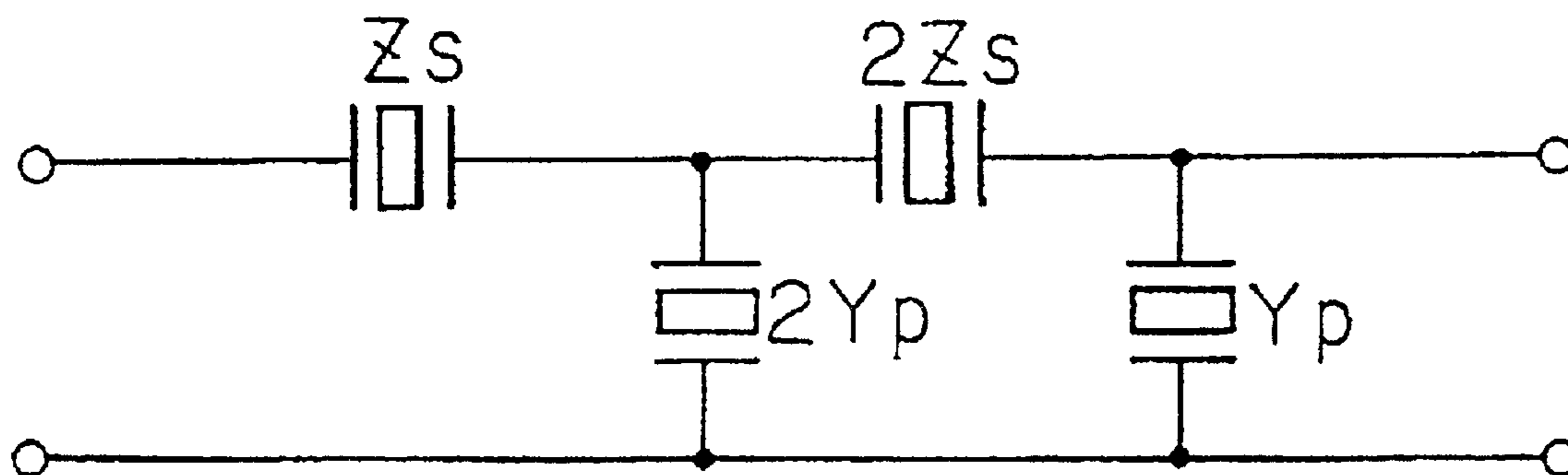
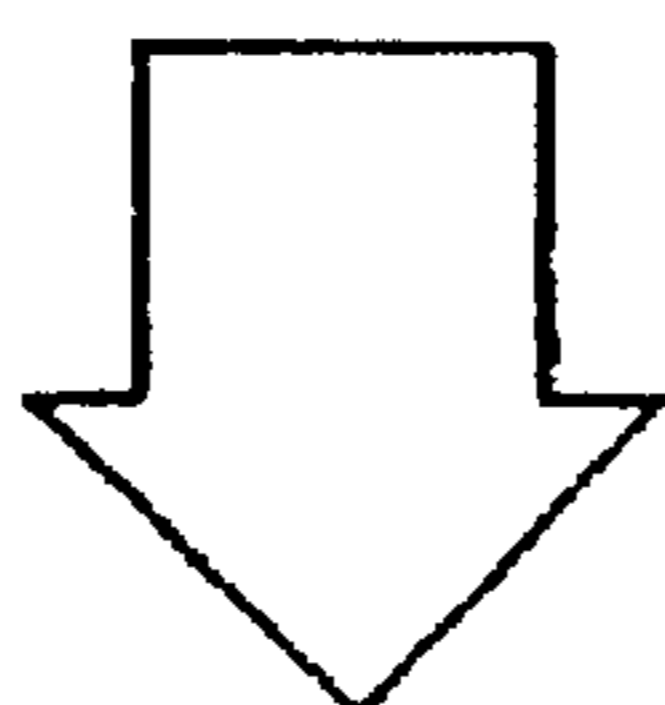
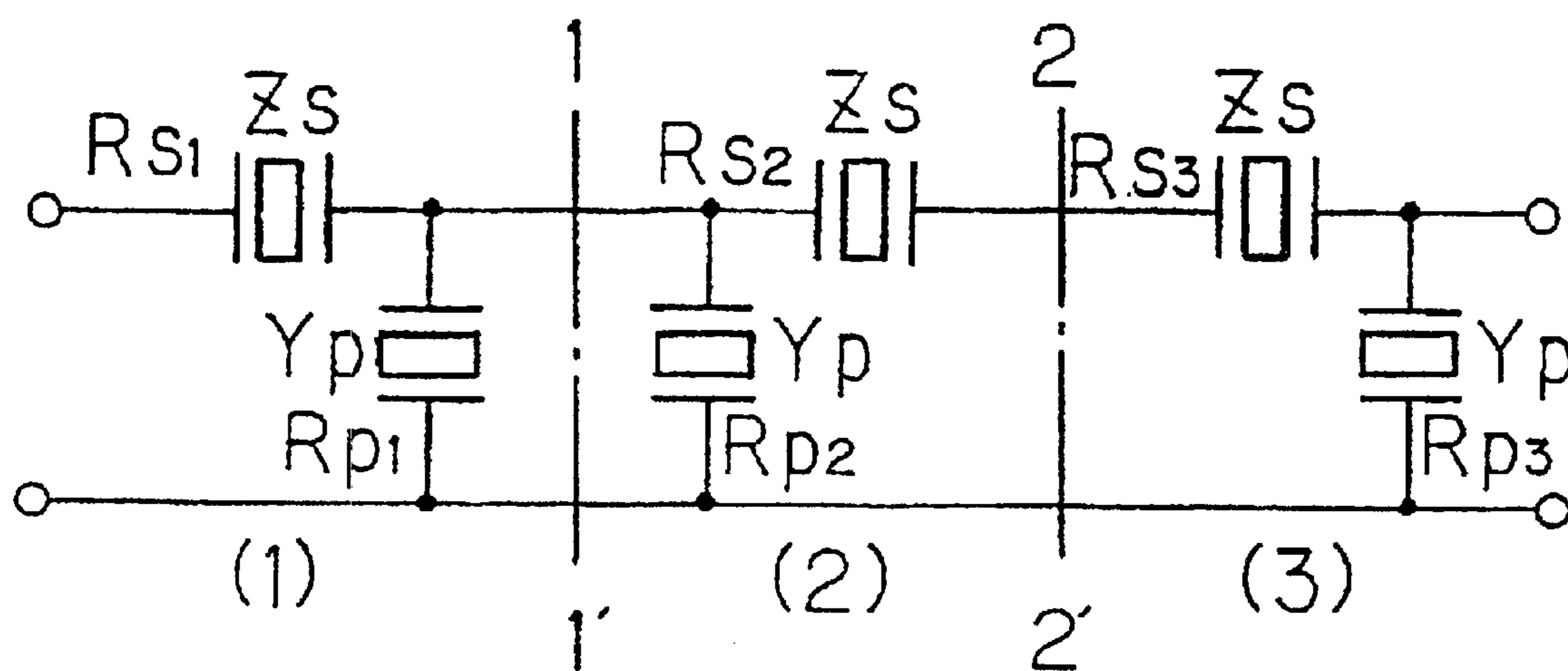

FIG. 55

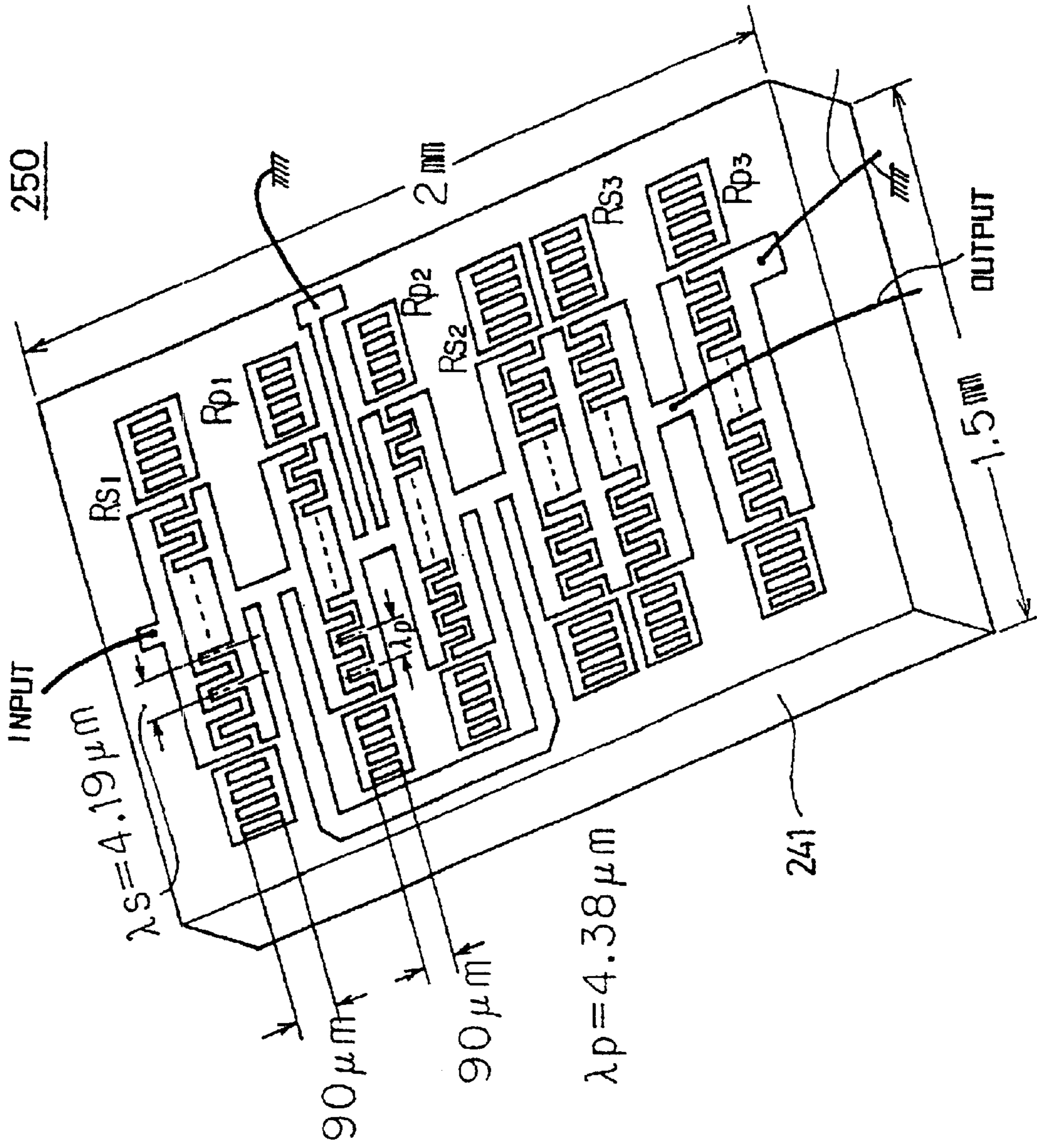

FIG. 56
(AMENDED)

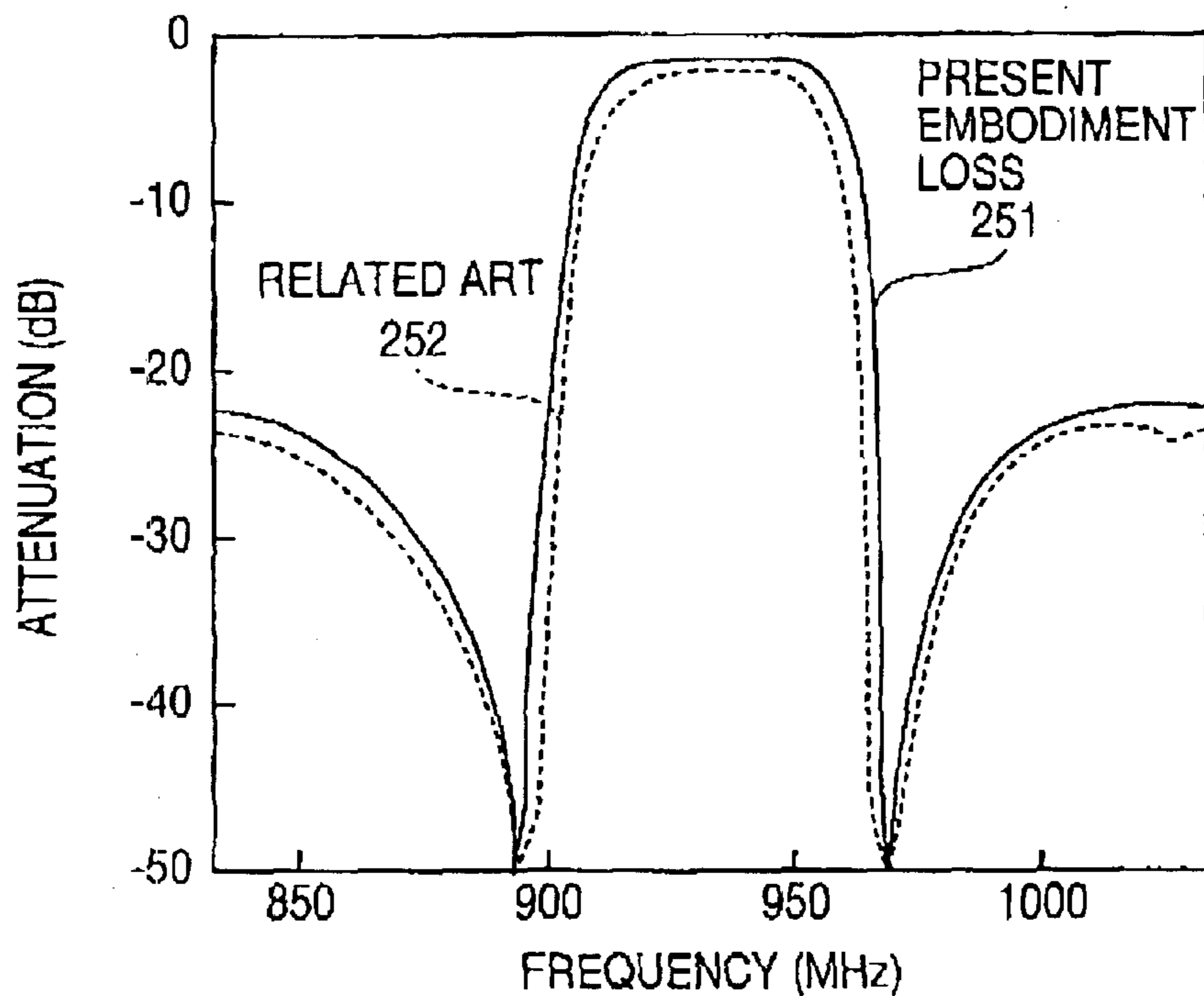

FIG. 57
(AMENDED)

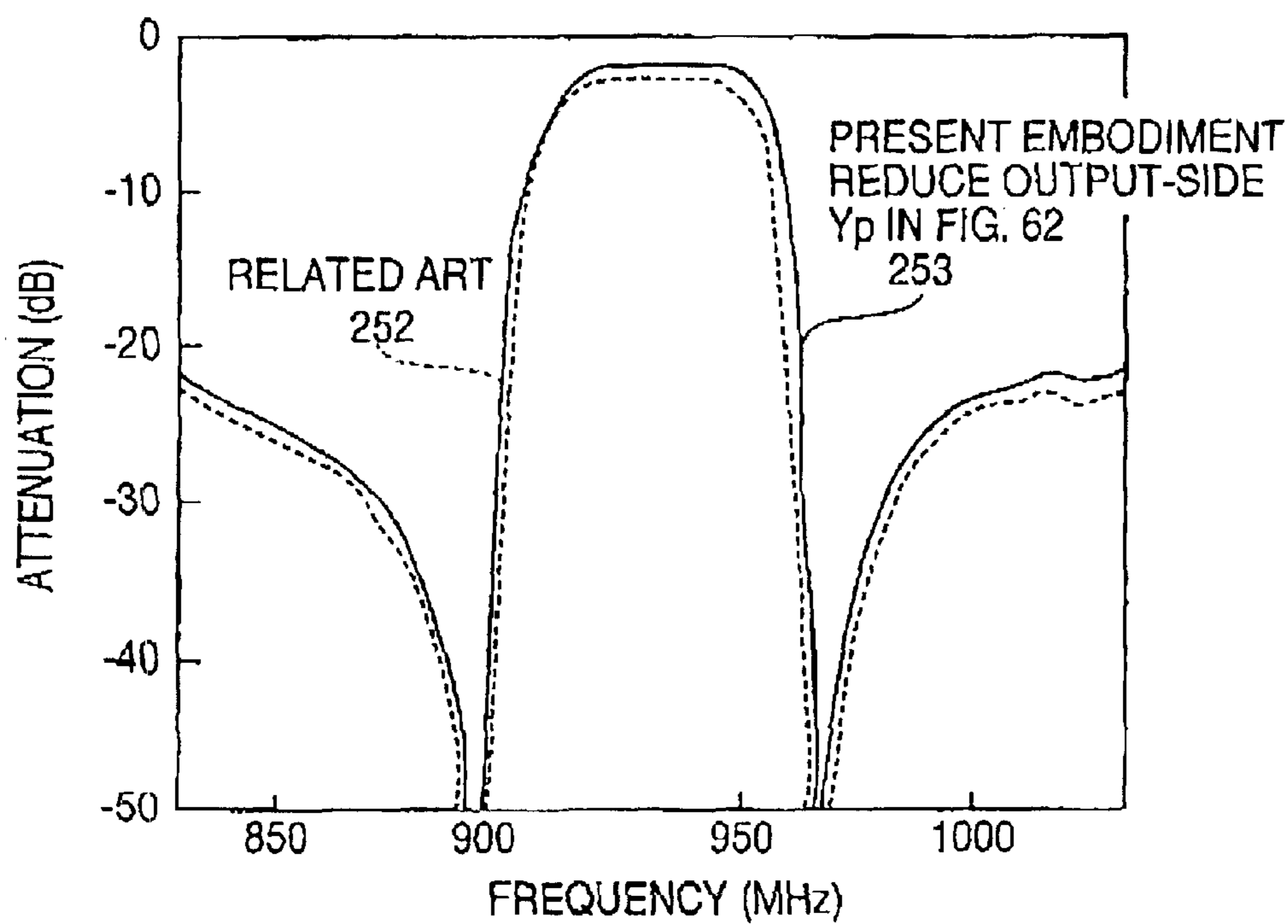

FIG. 58A

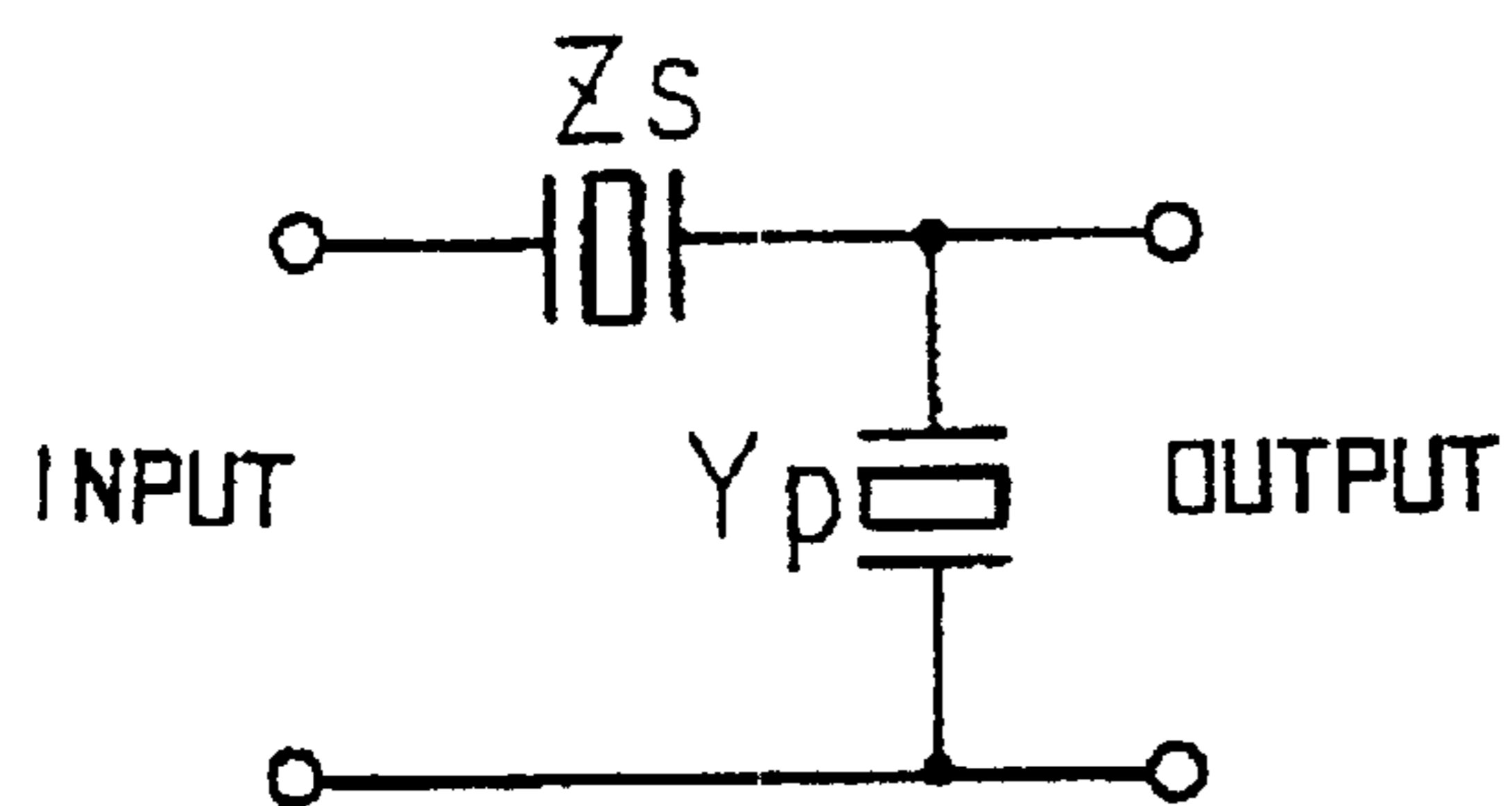

FIG. 58B

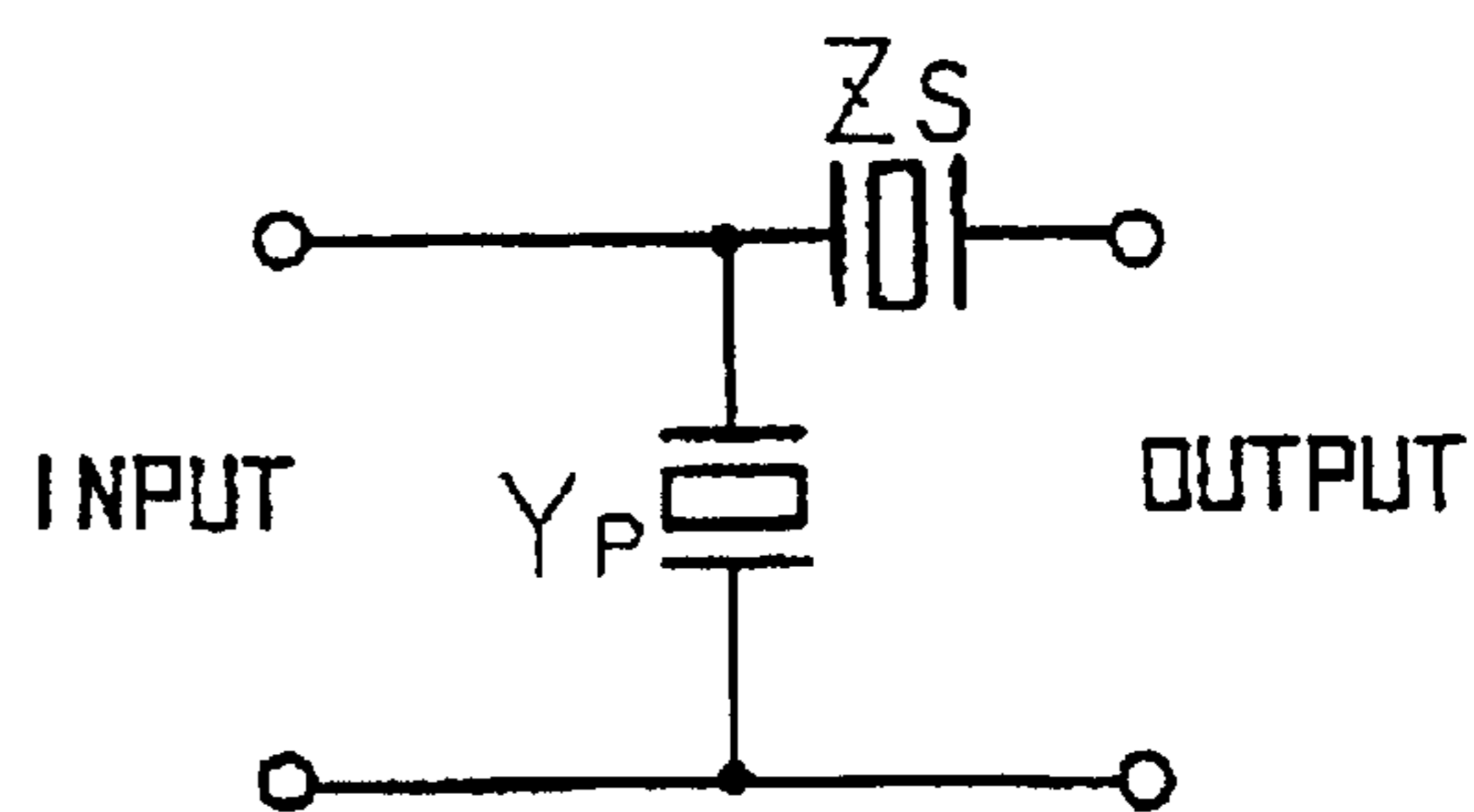

FIG. 60

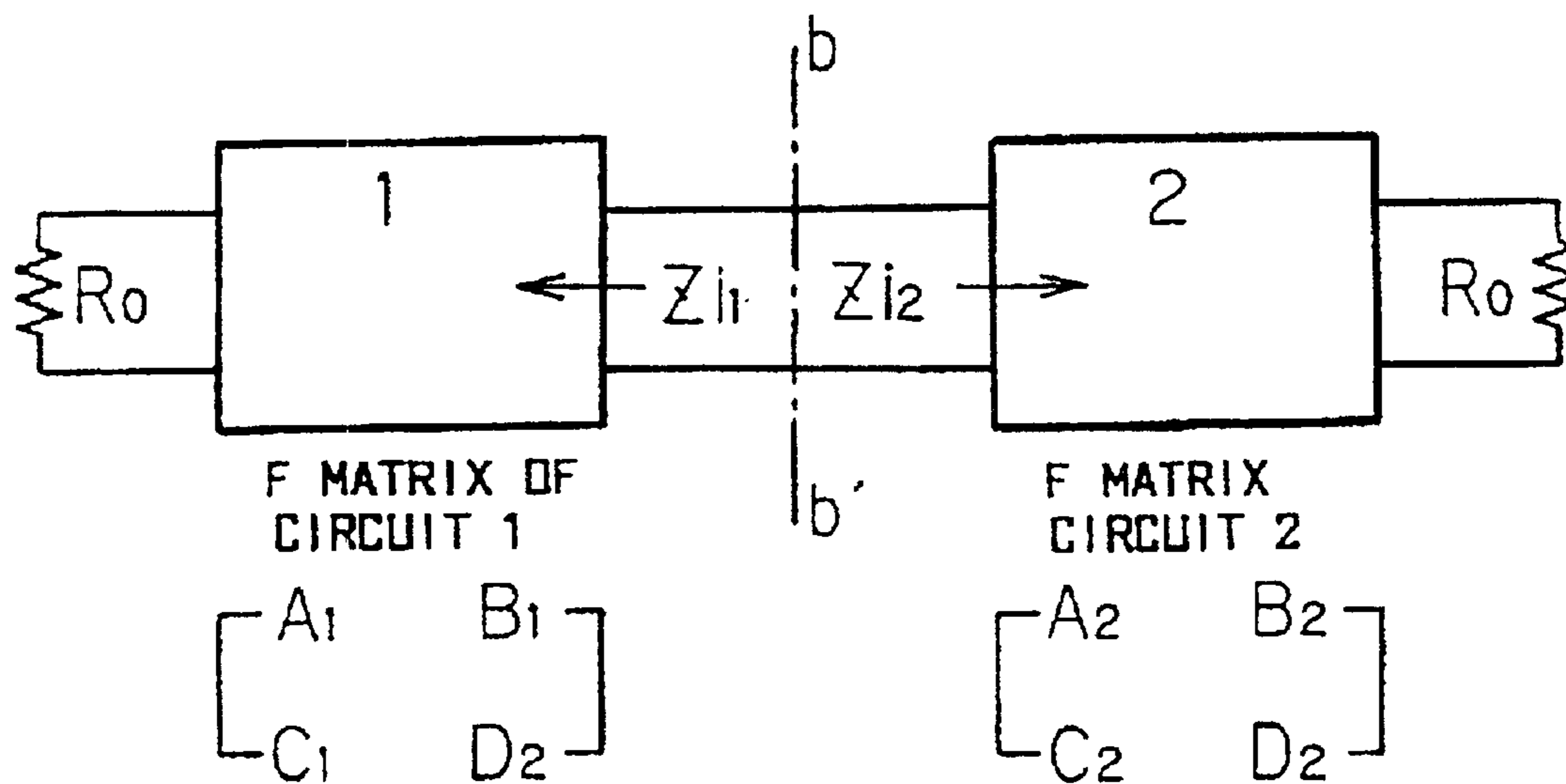

FIG. 59A

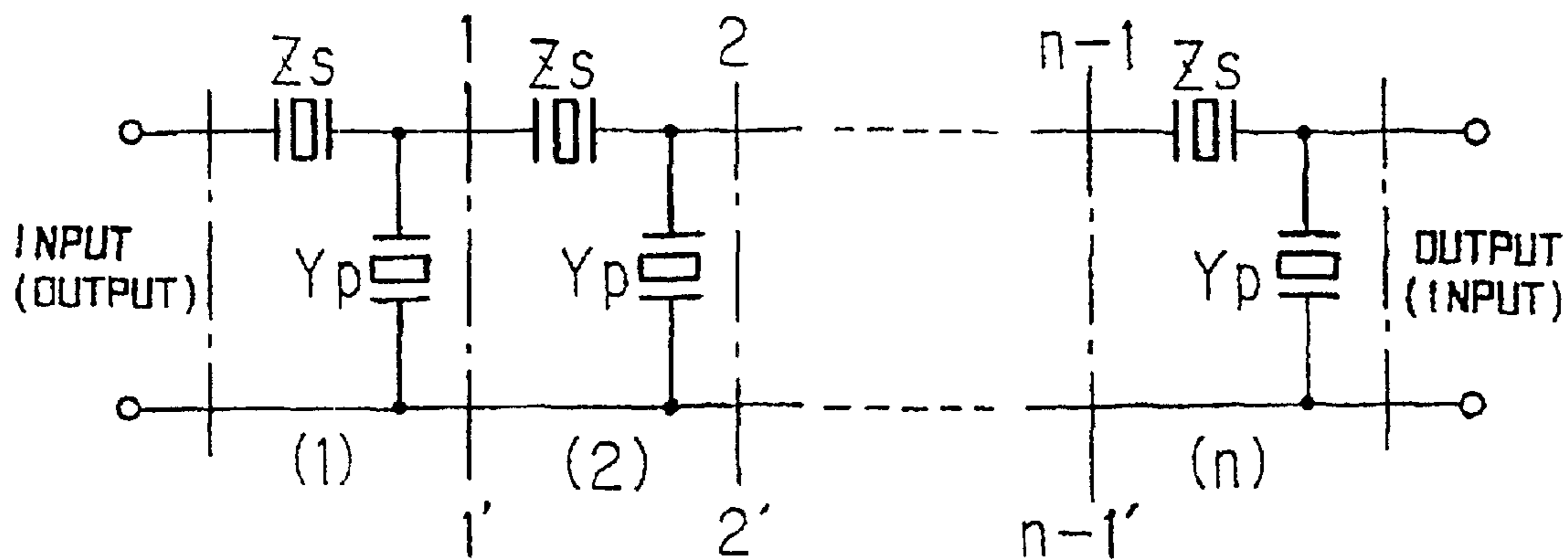

FIG. 59B

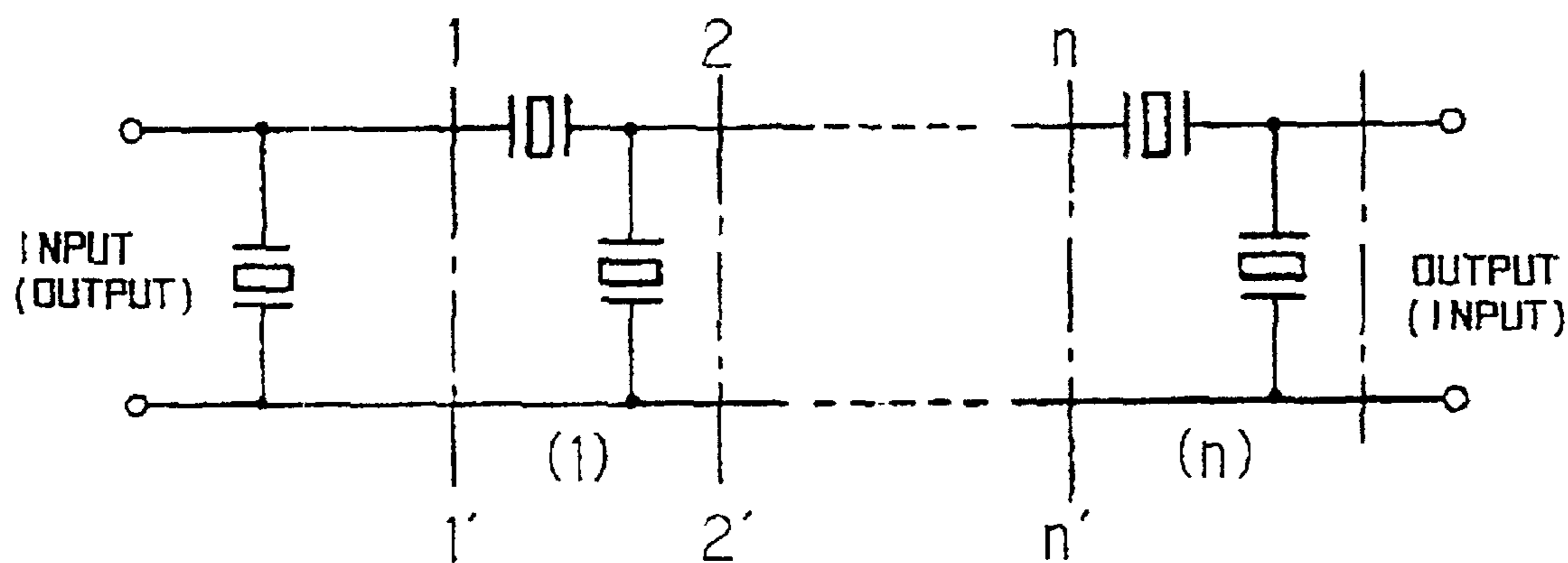

FIG. 59C

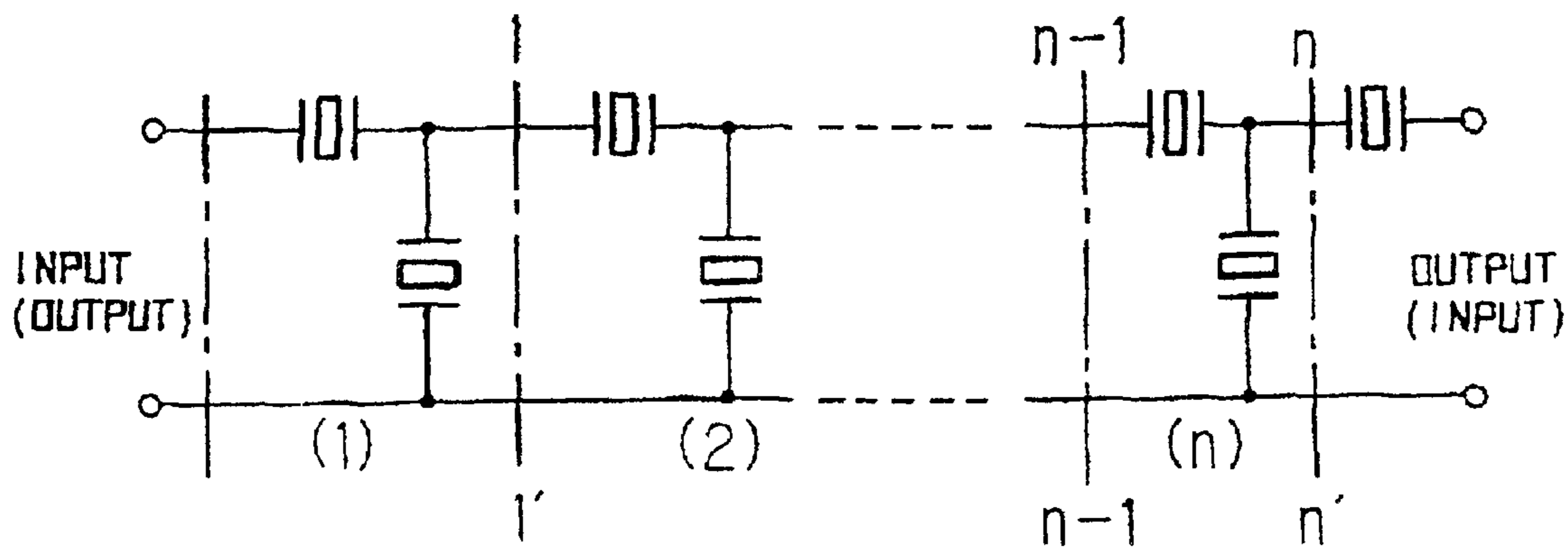

FIG. 61A

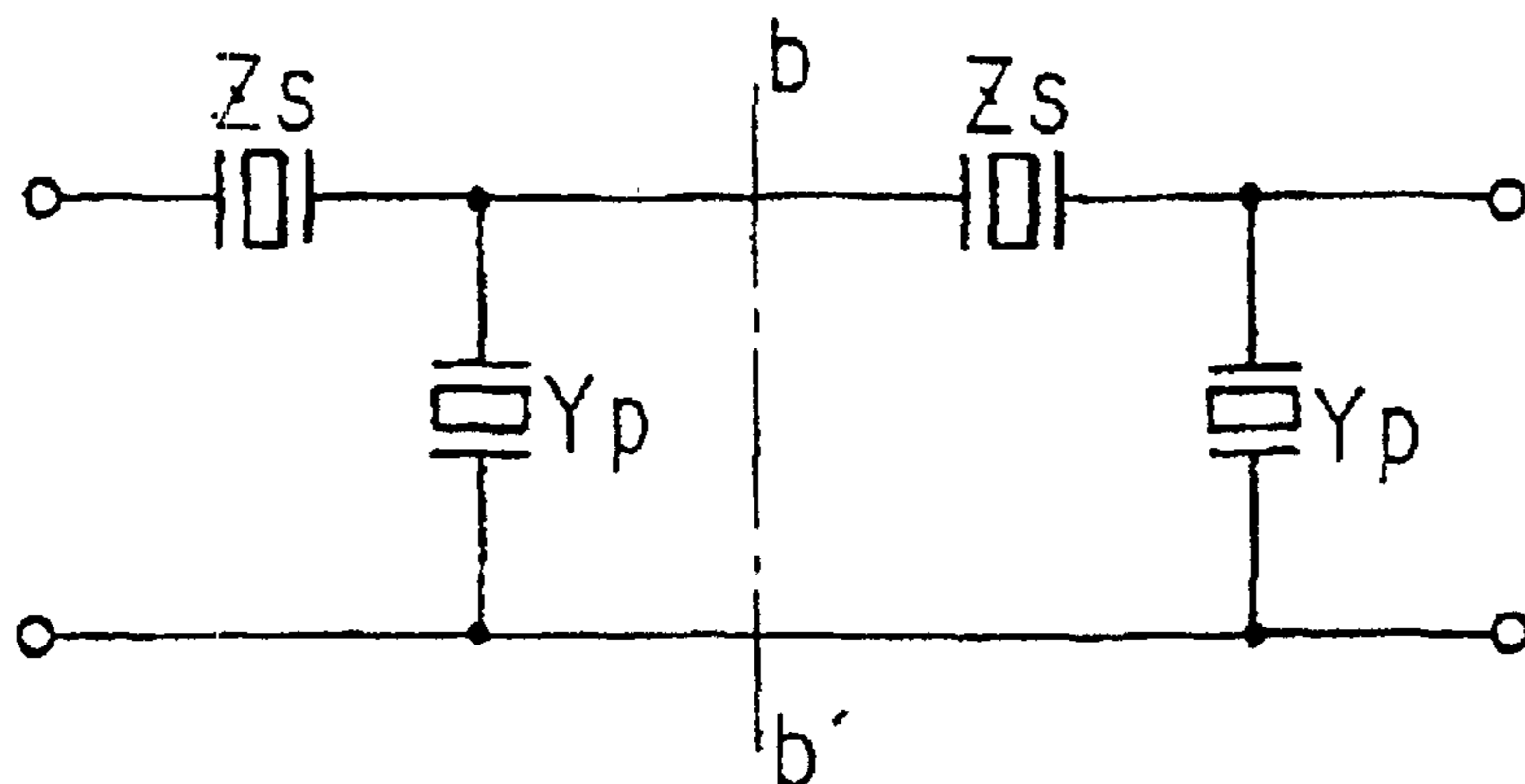

FIG. 61B

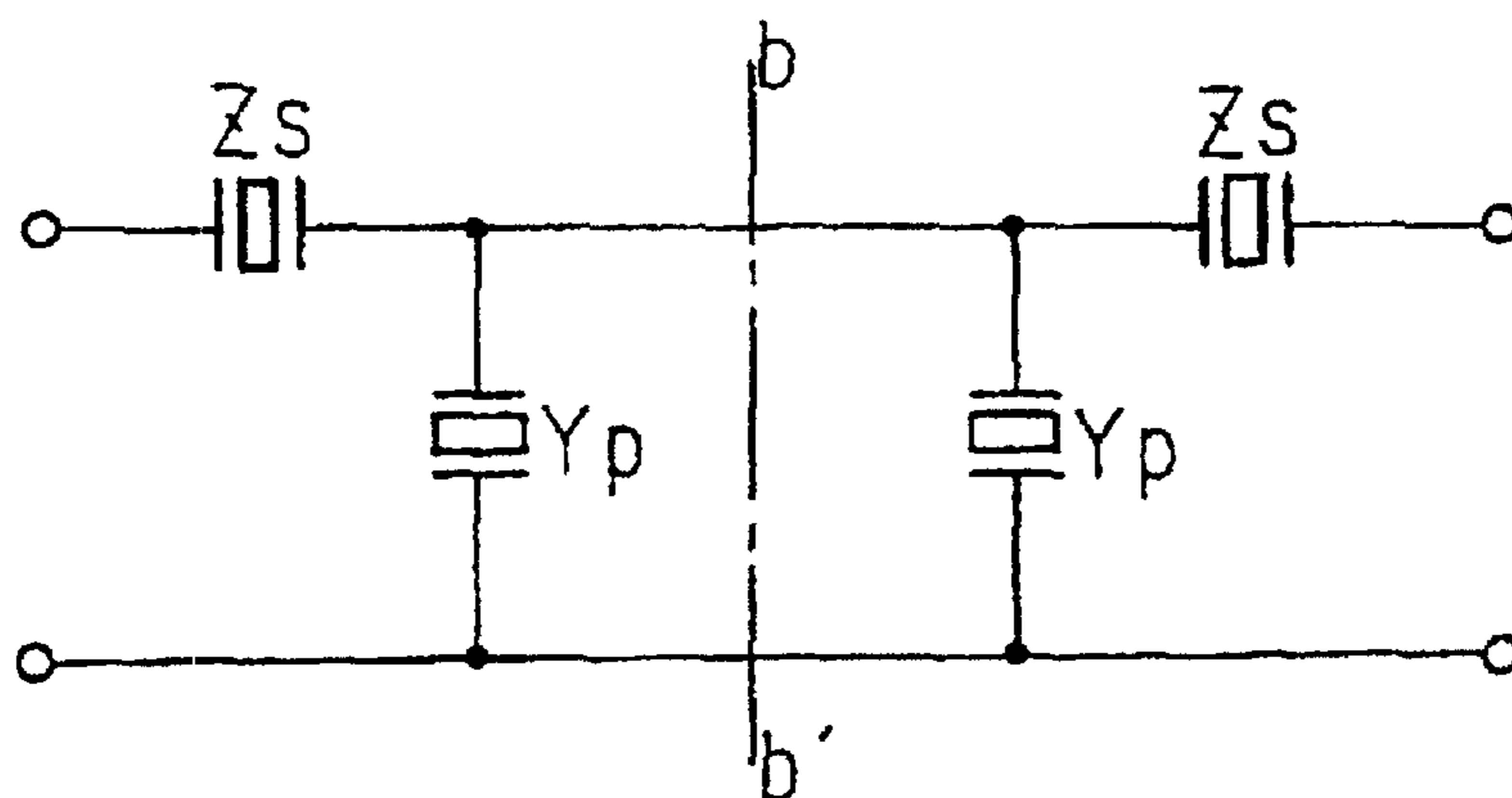

FIG. 61C

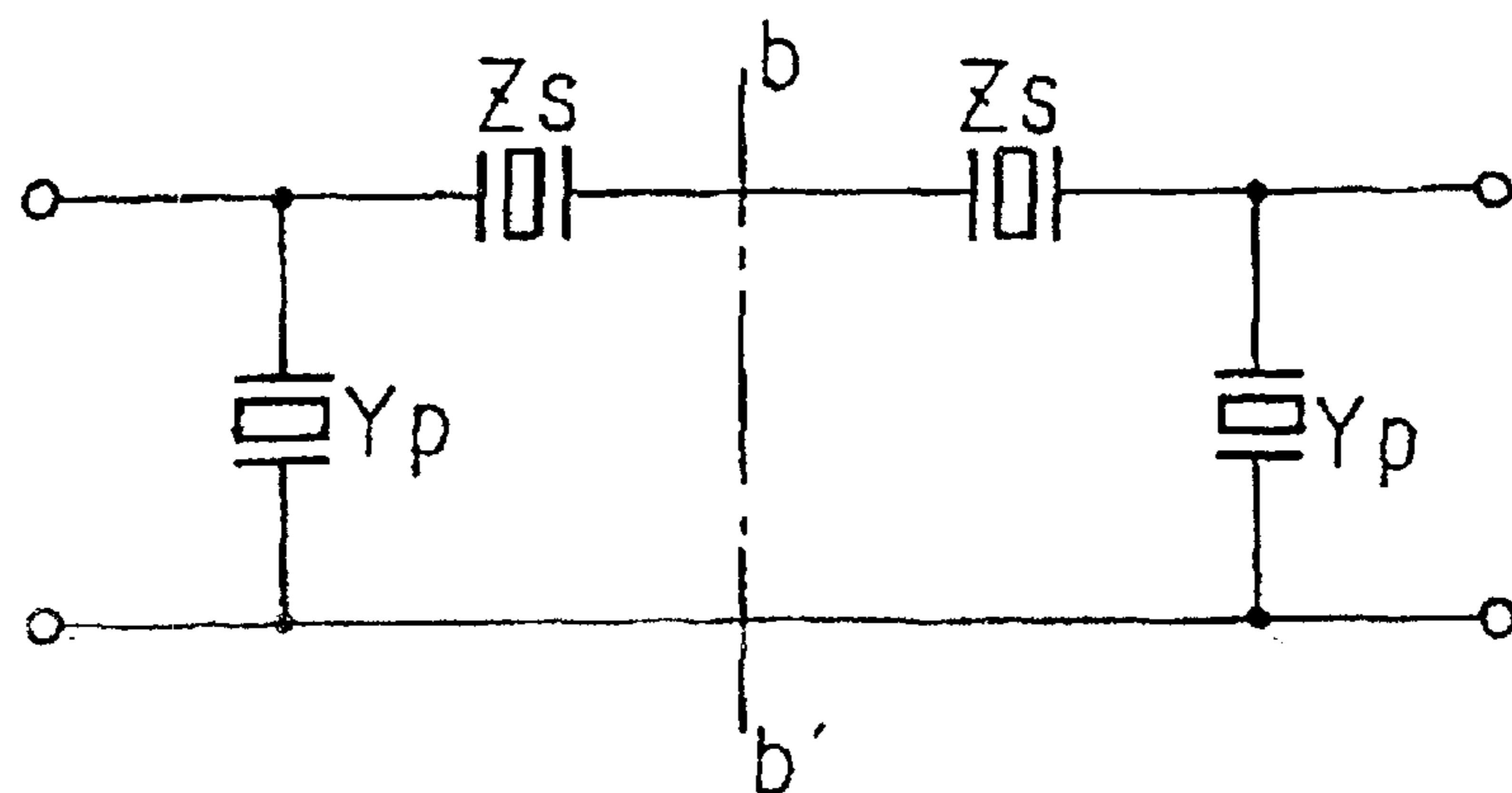
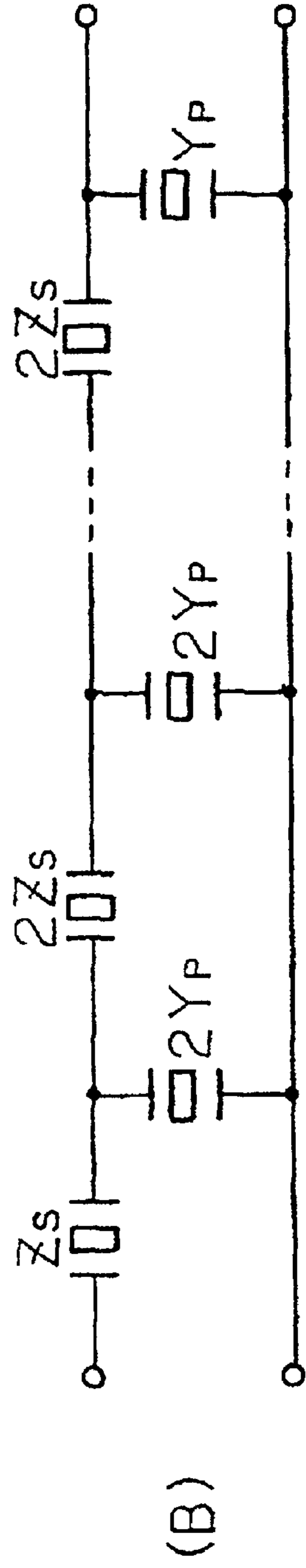
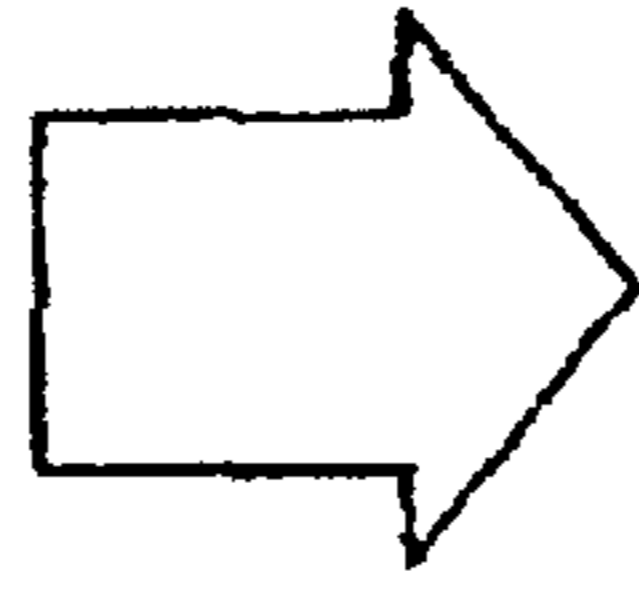
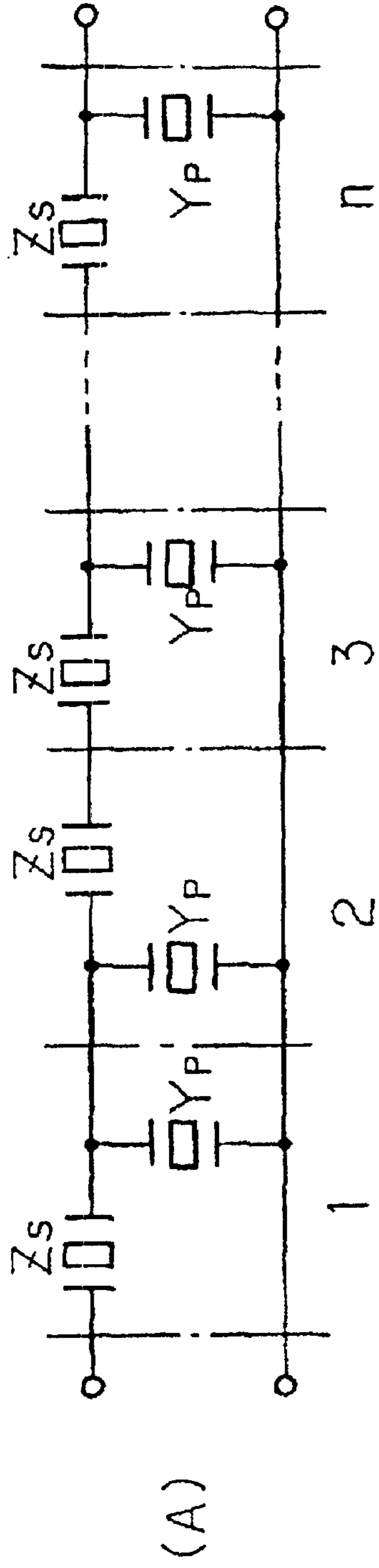

FIG. 62



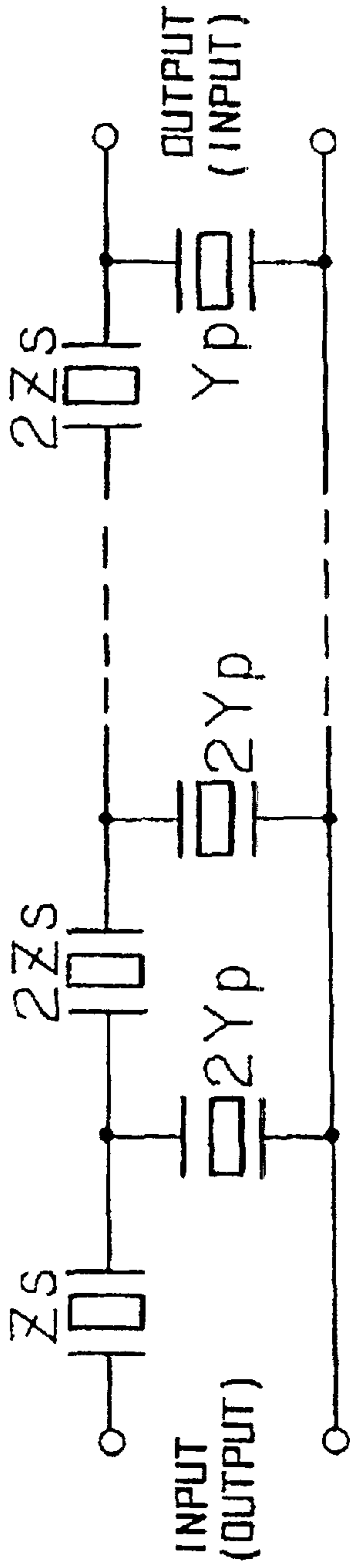

FIG. 63A

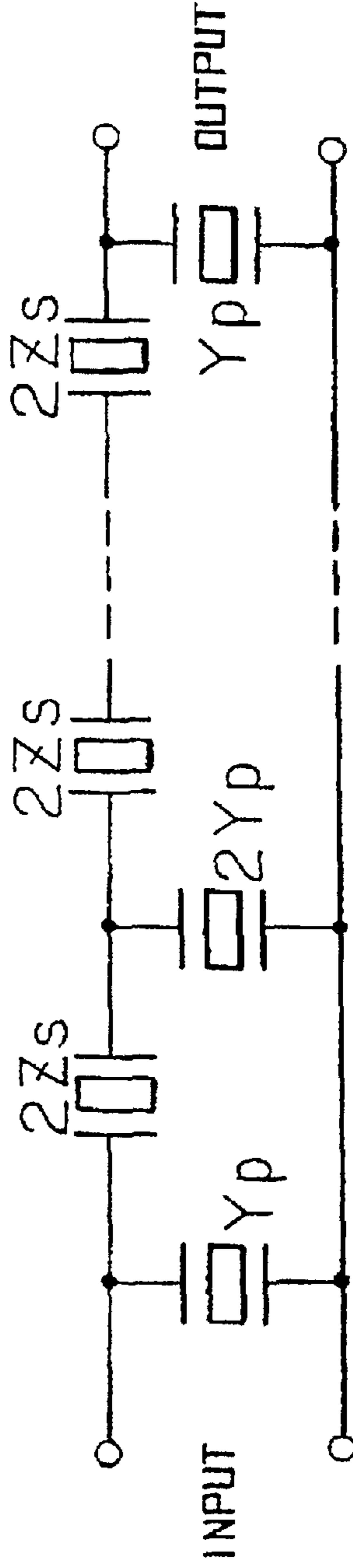

FIG. 63B

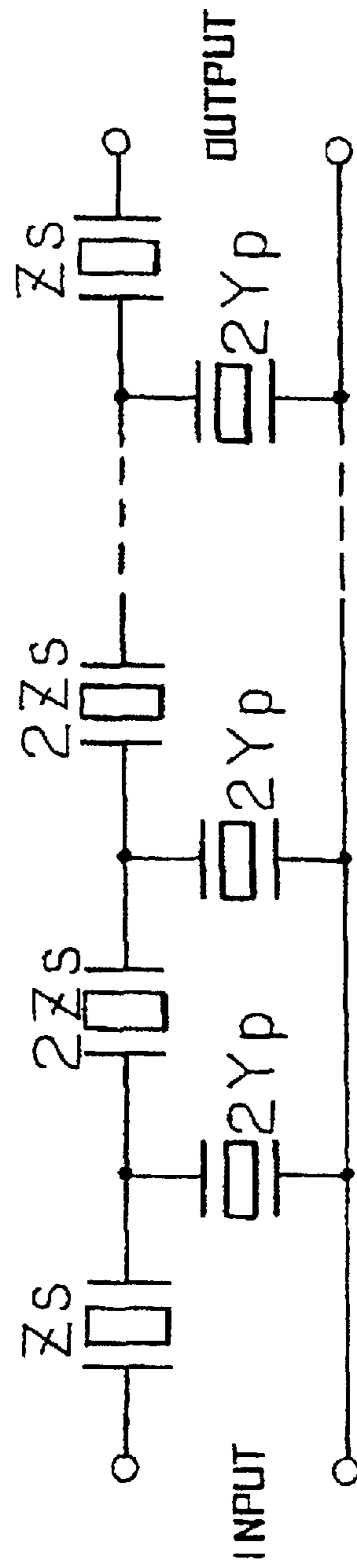

FIG. 63C

FIG. 64 RELATED ART
(AMENDED)

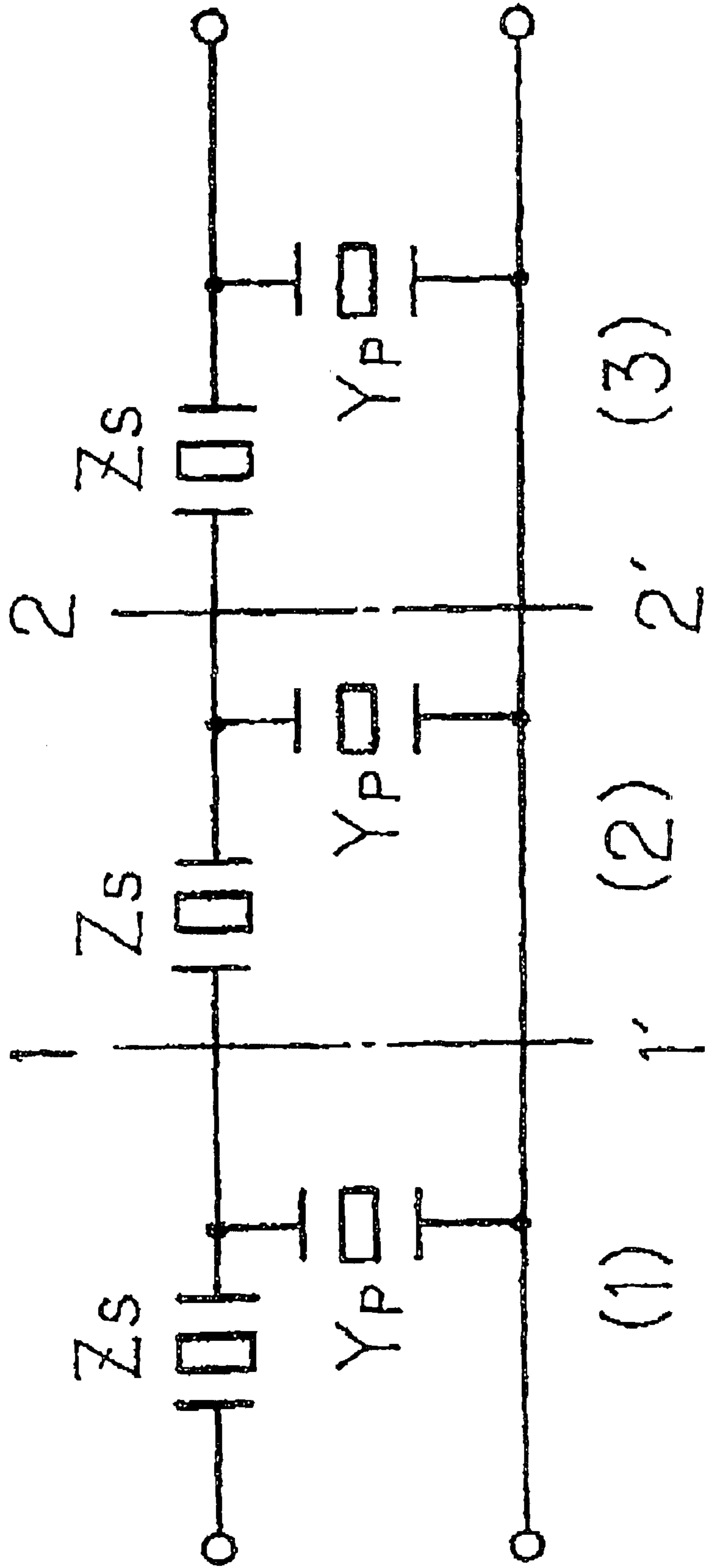
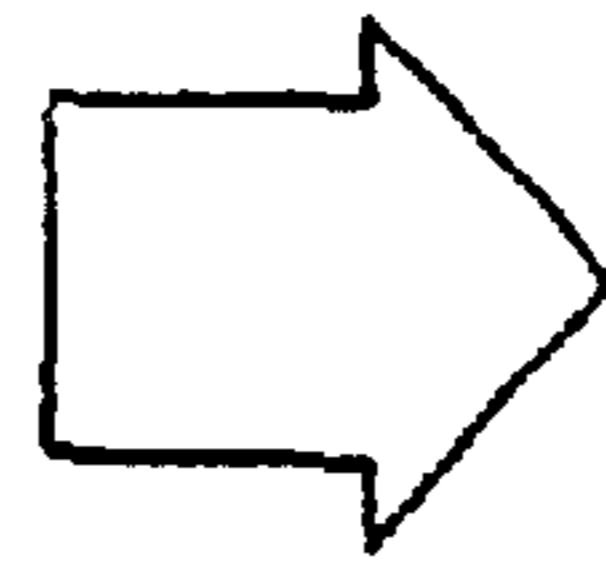
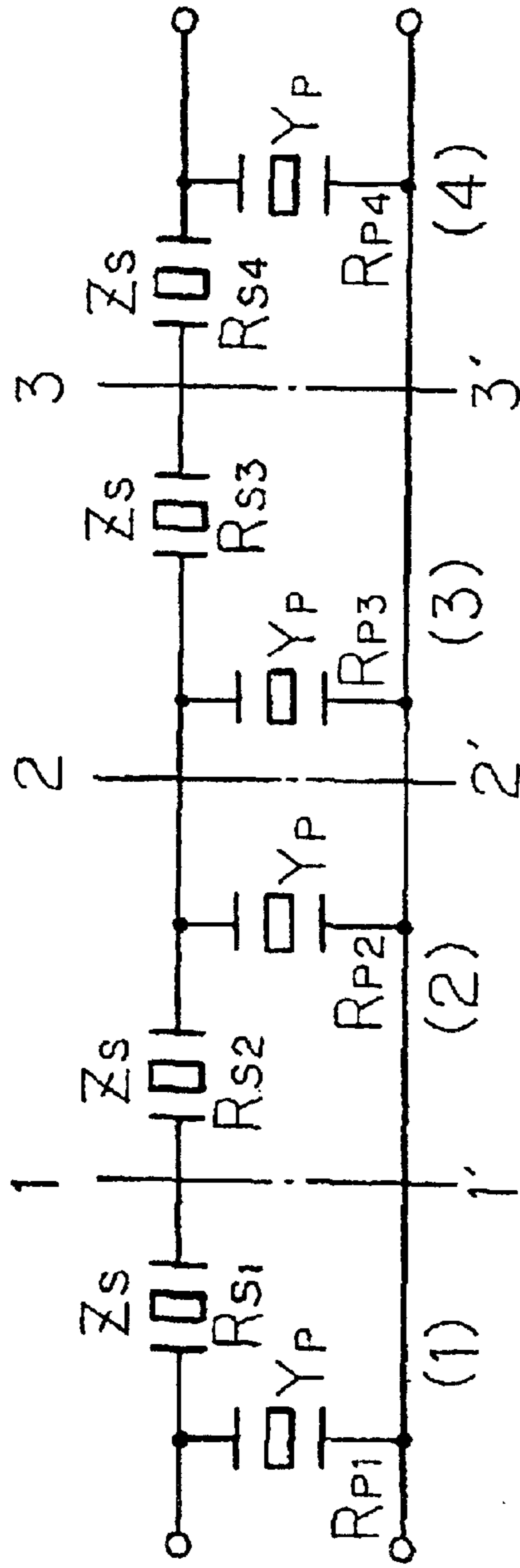

FIG. 65



260

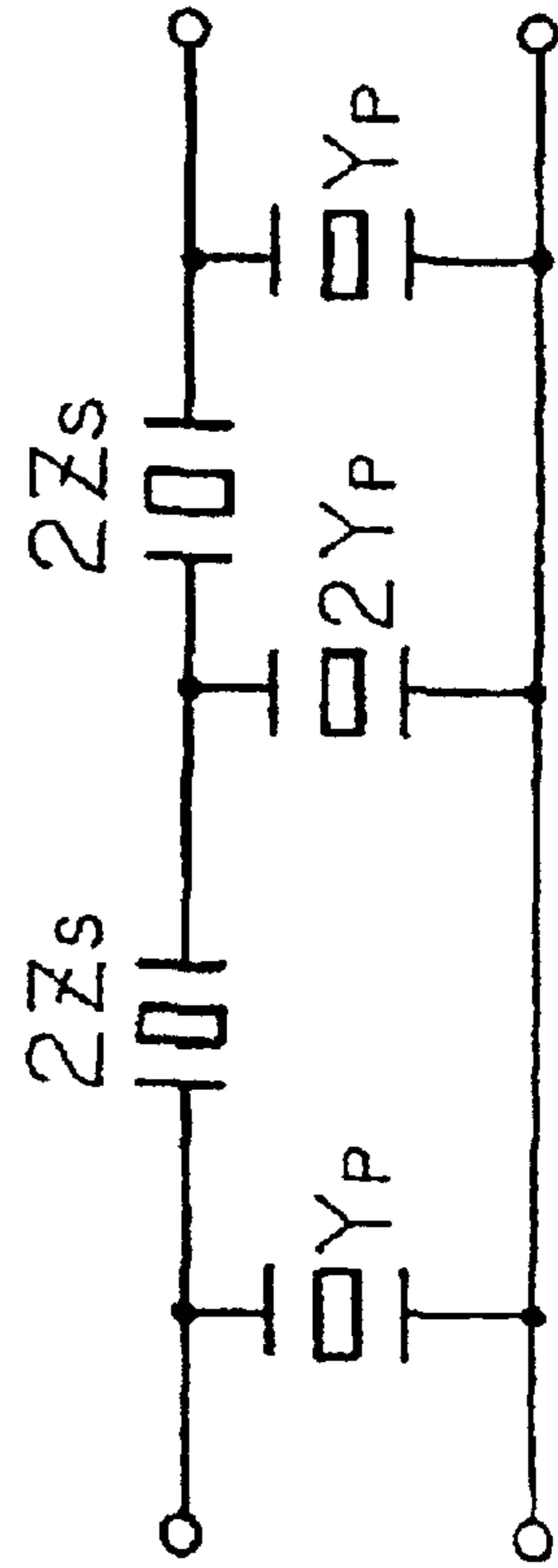
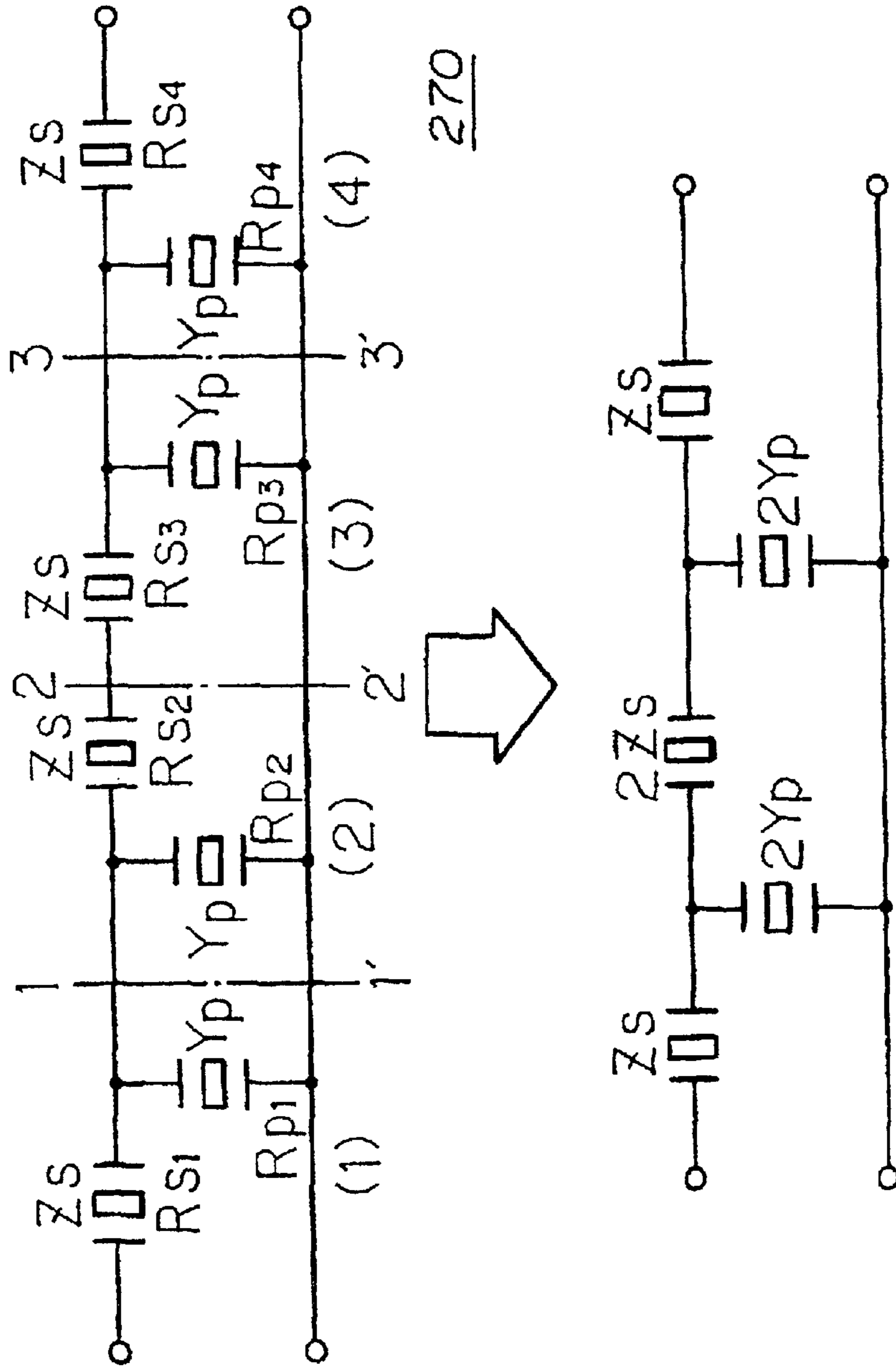

FIG. 66



270

FIG. 67

280

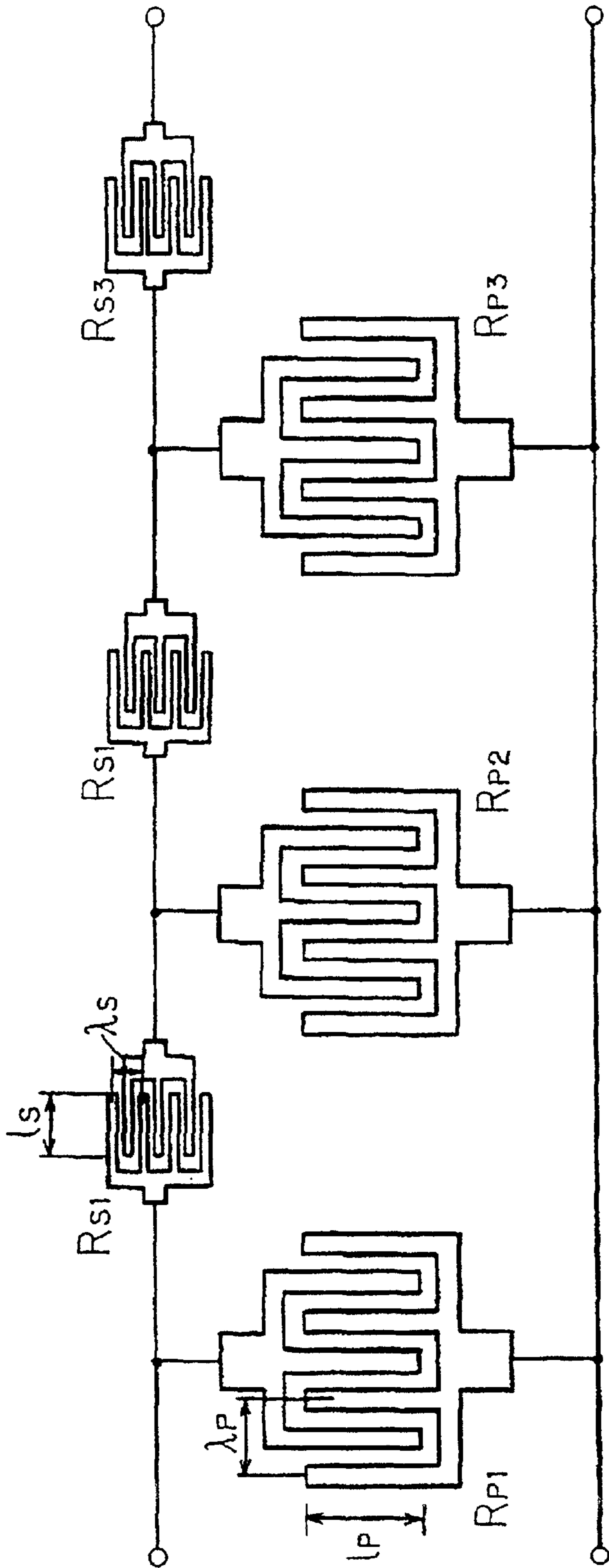

FIG. 68

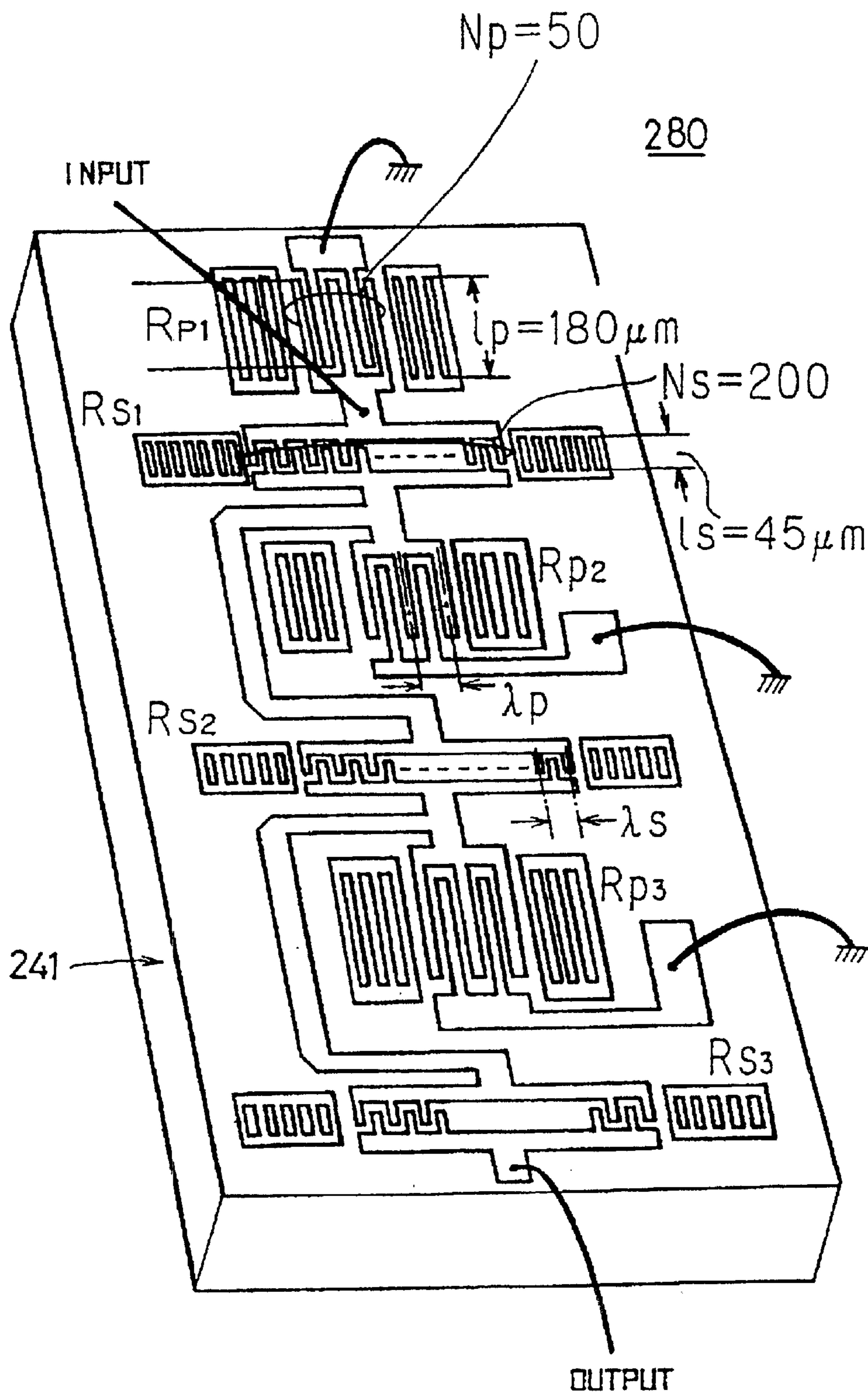

FIG. 69

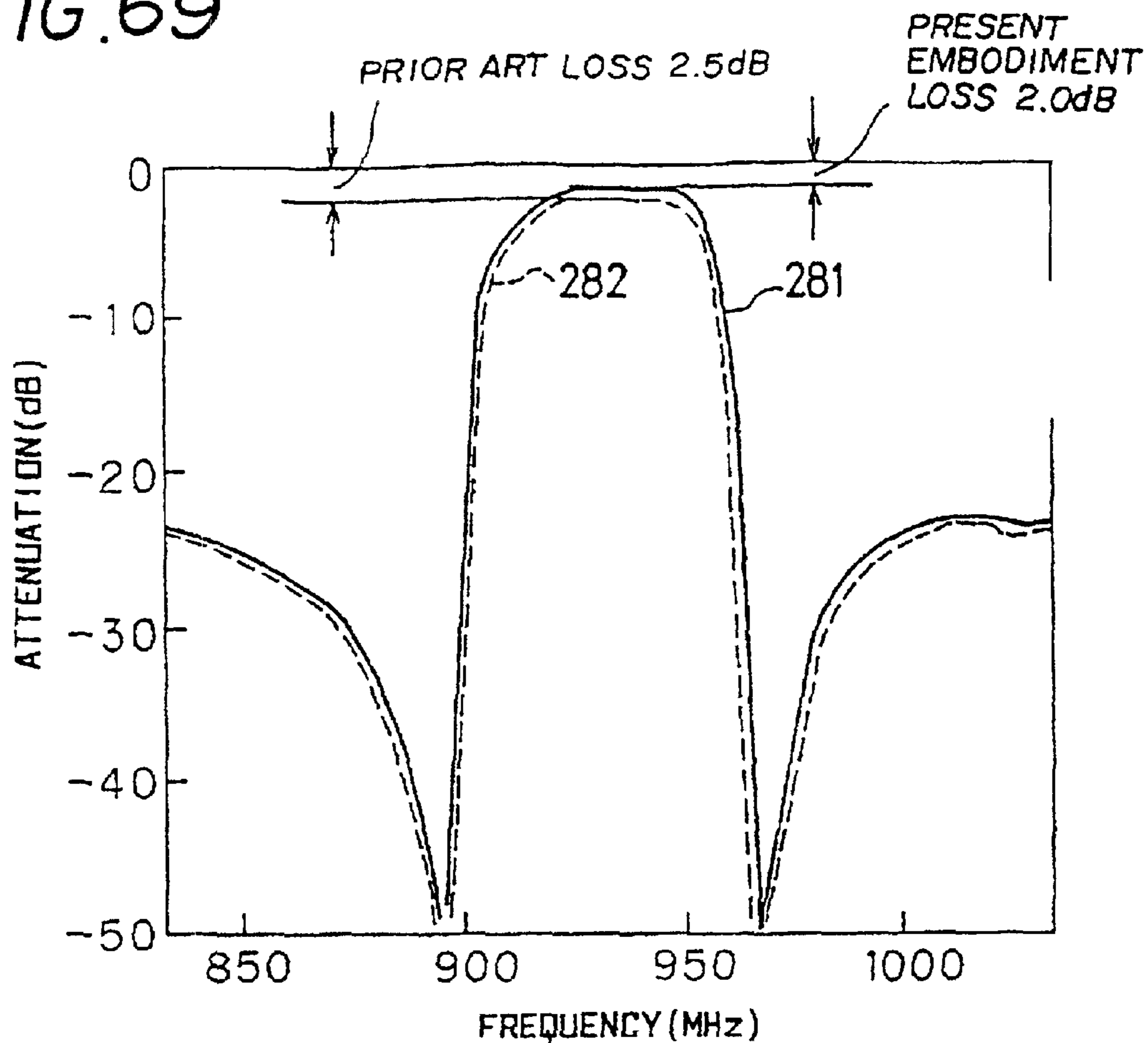

FIG. 70

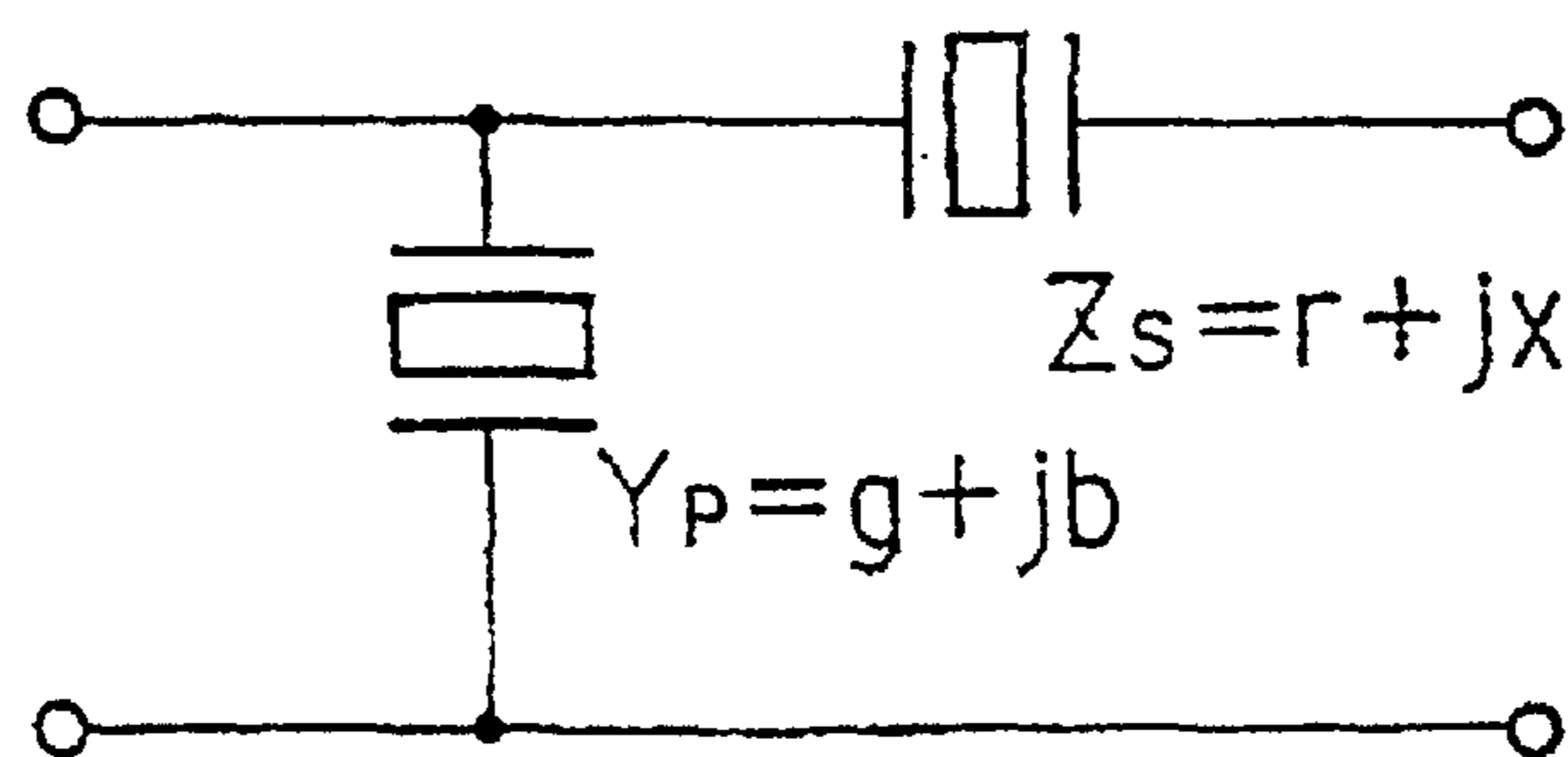

FIG. 71A

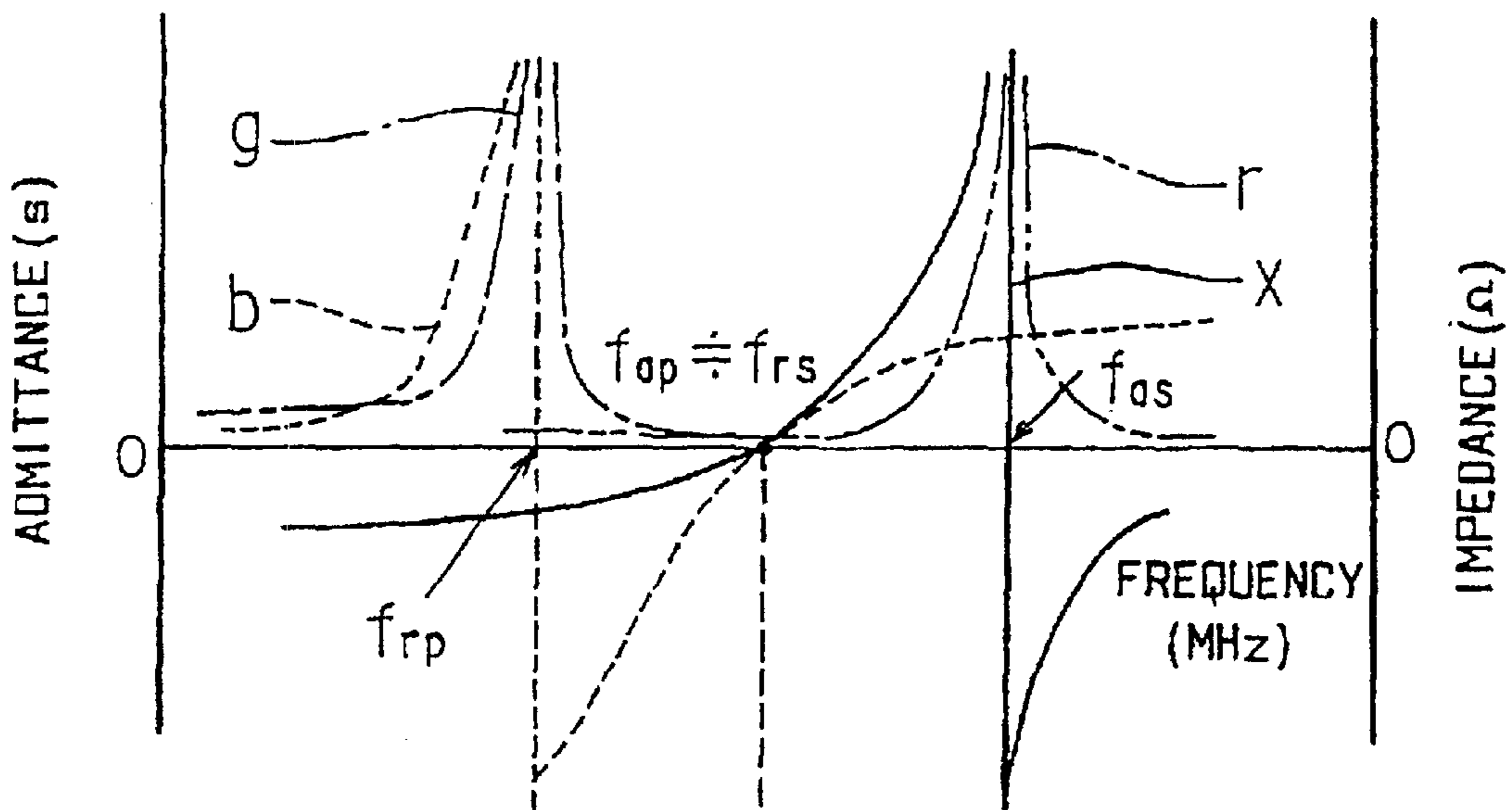

FIG. 71B

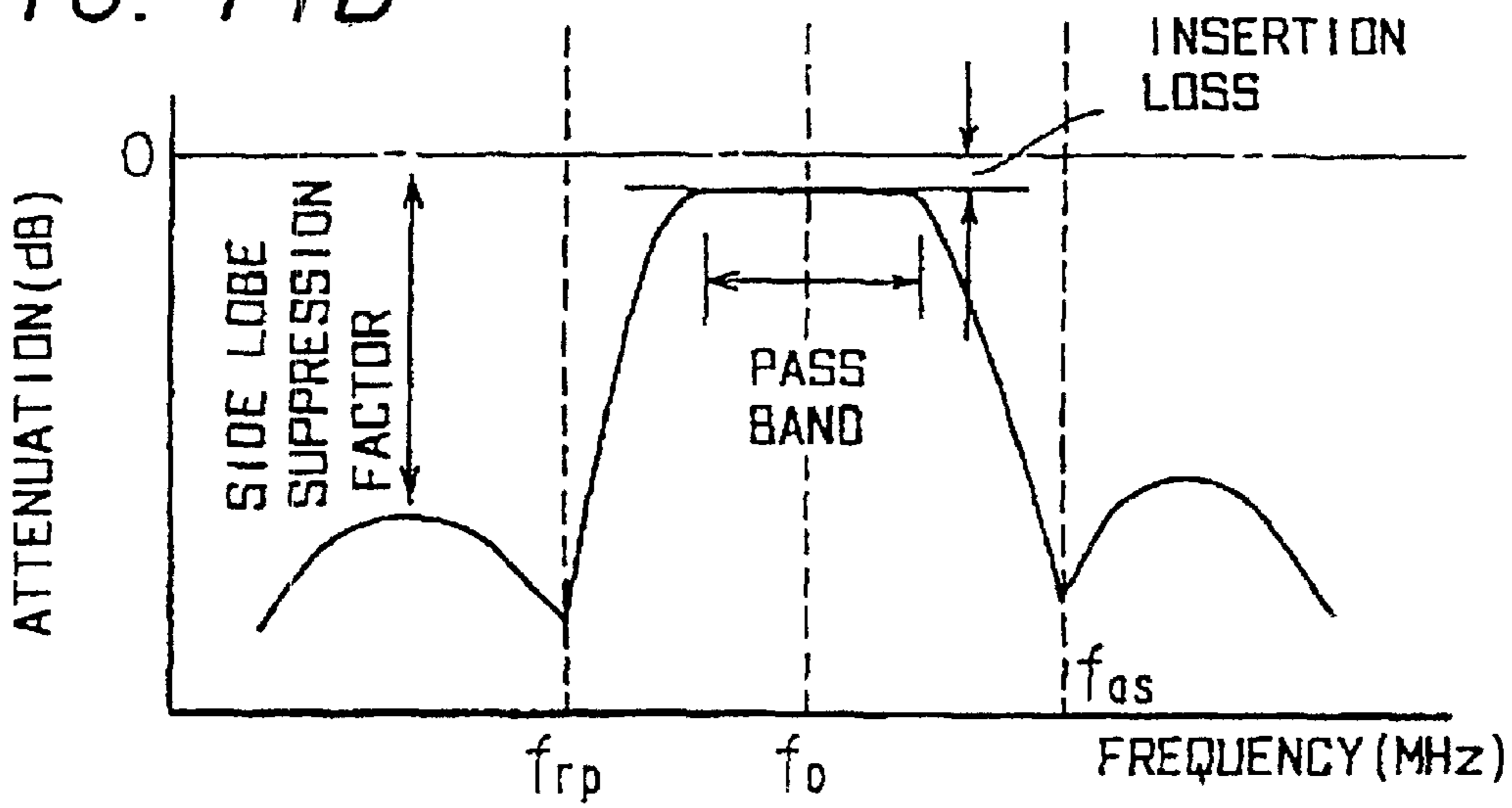

FIG. 72

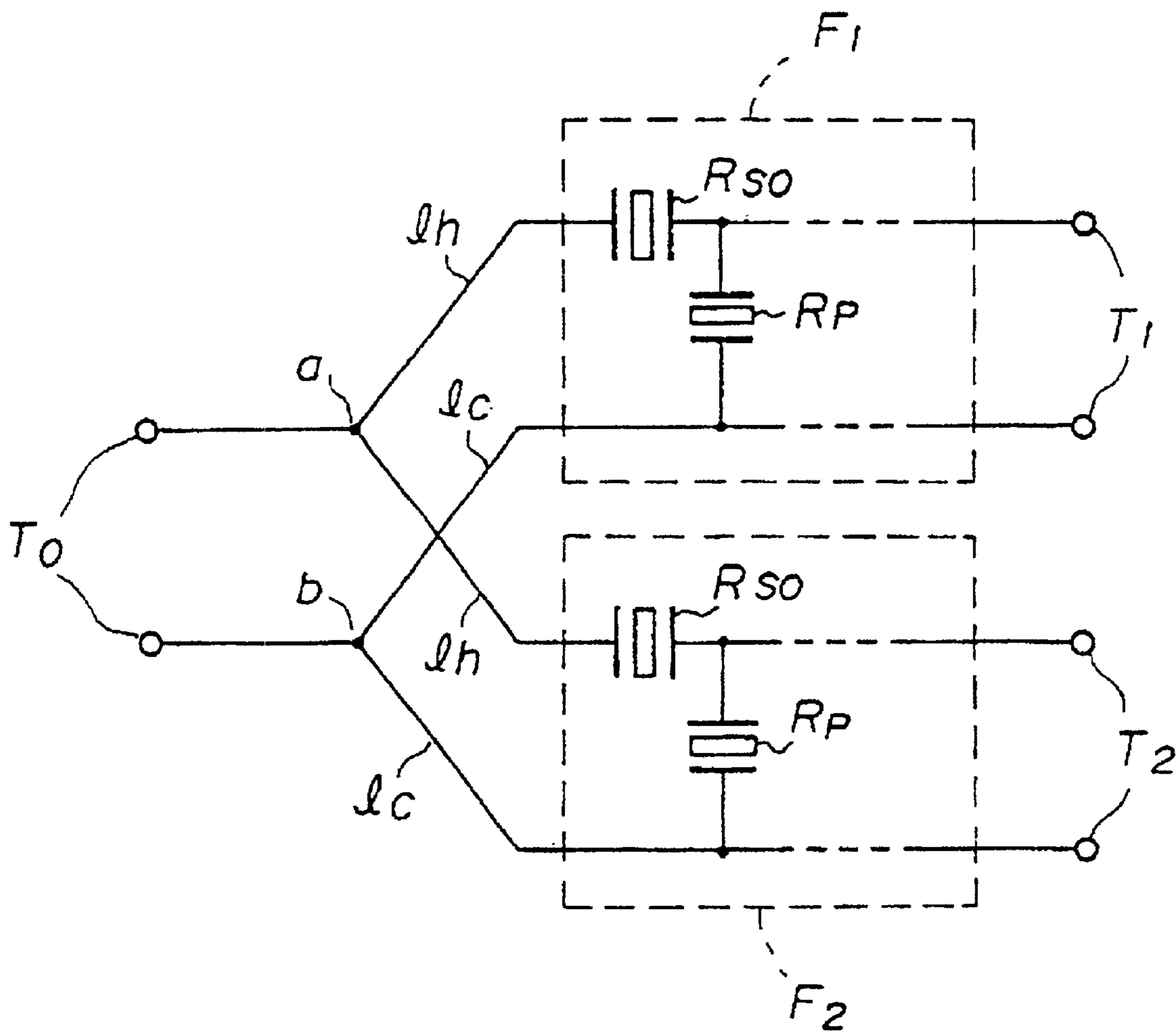

FIG. 73

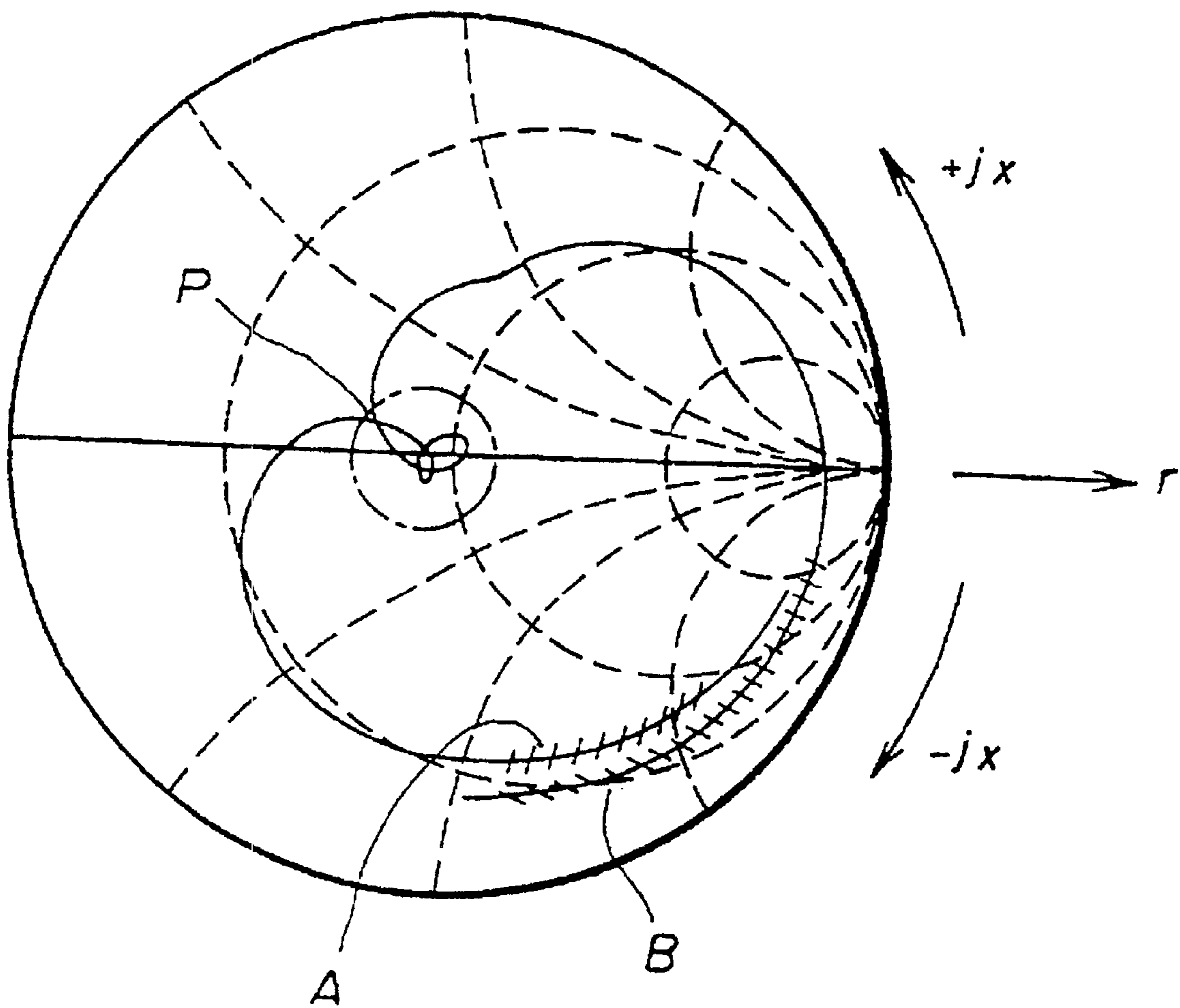

FIG. 74

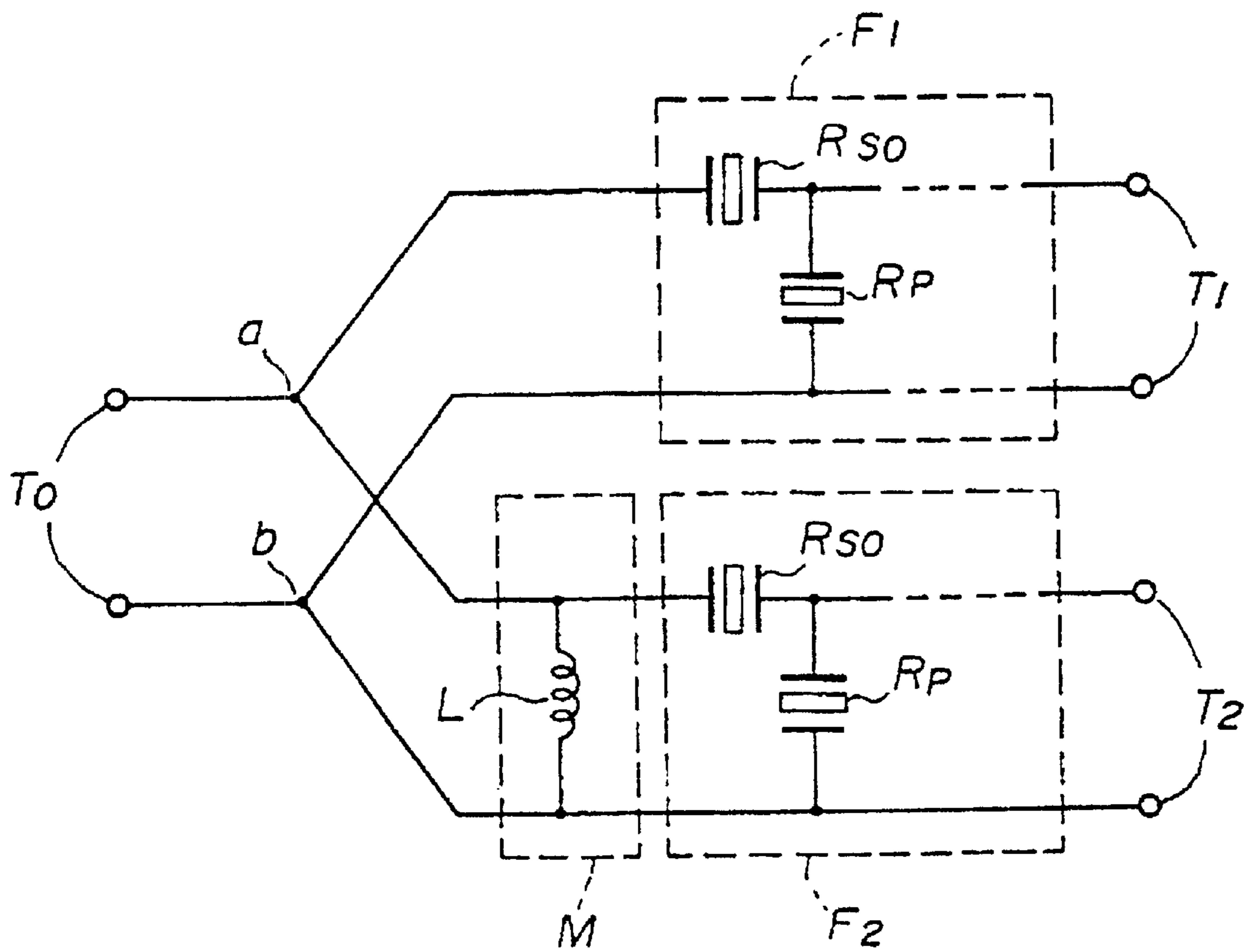

FIG. 75

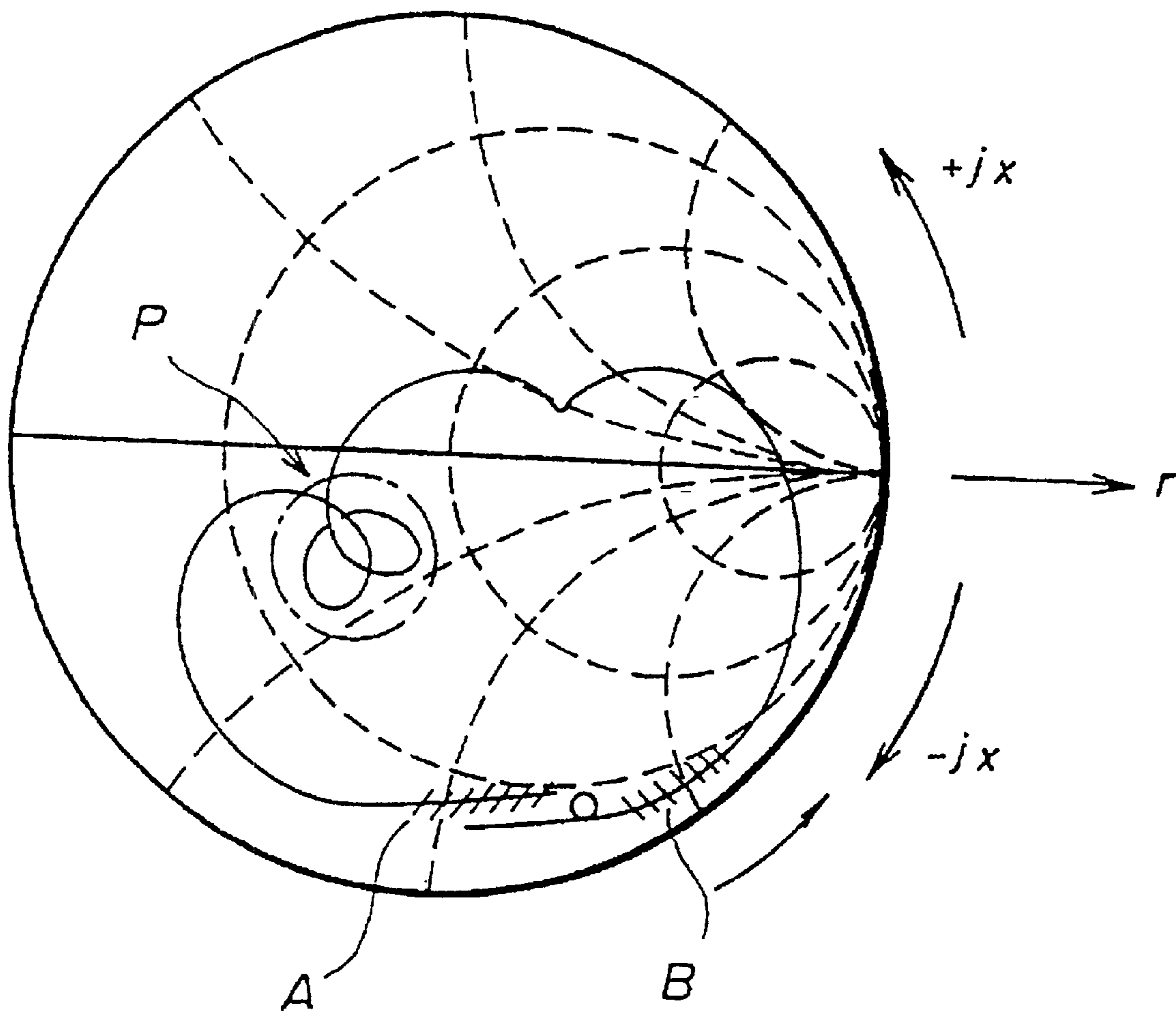

FIG. 76

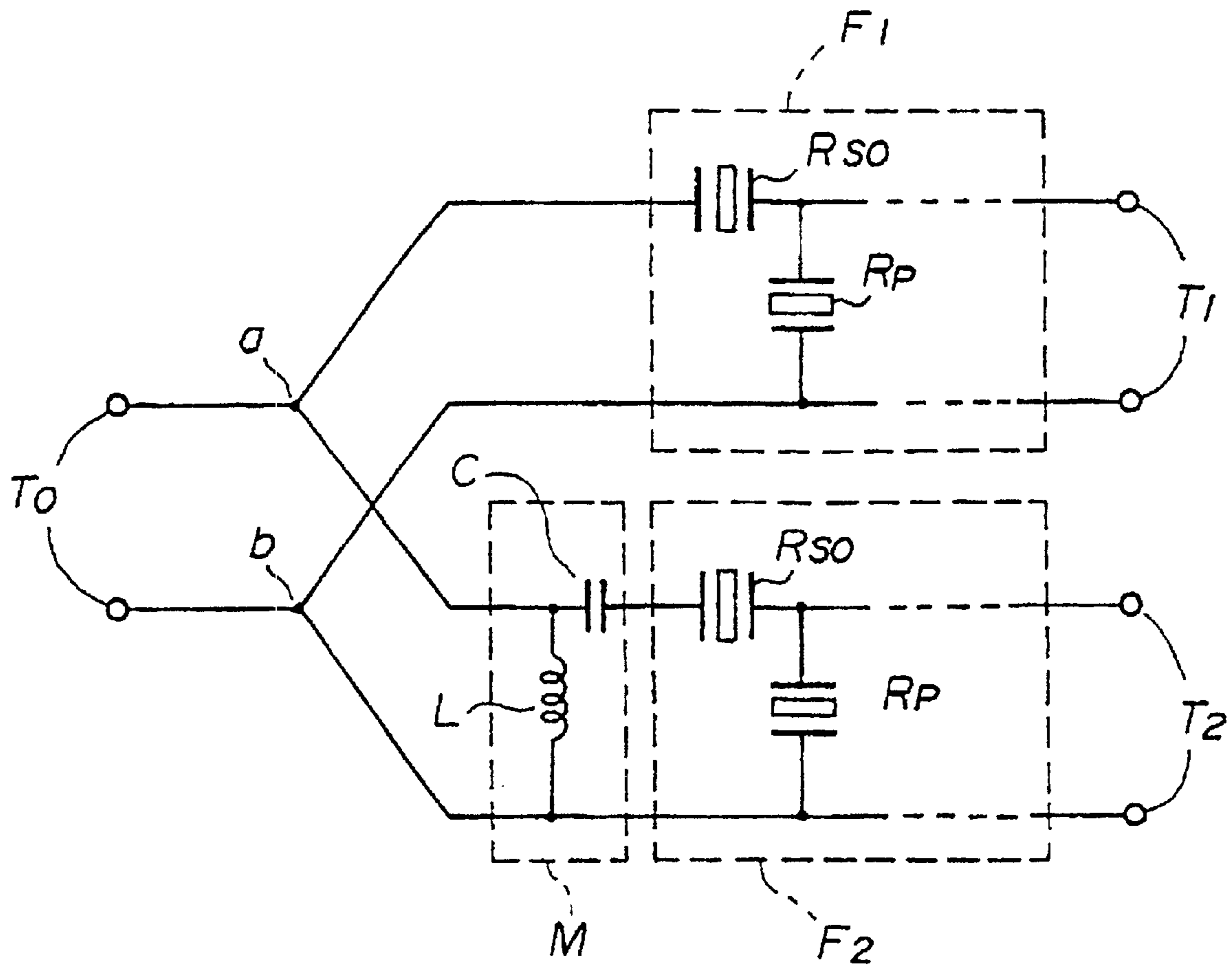

FIG. 77

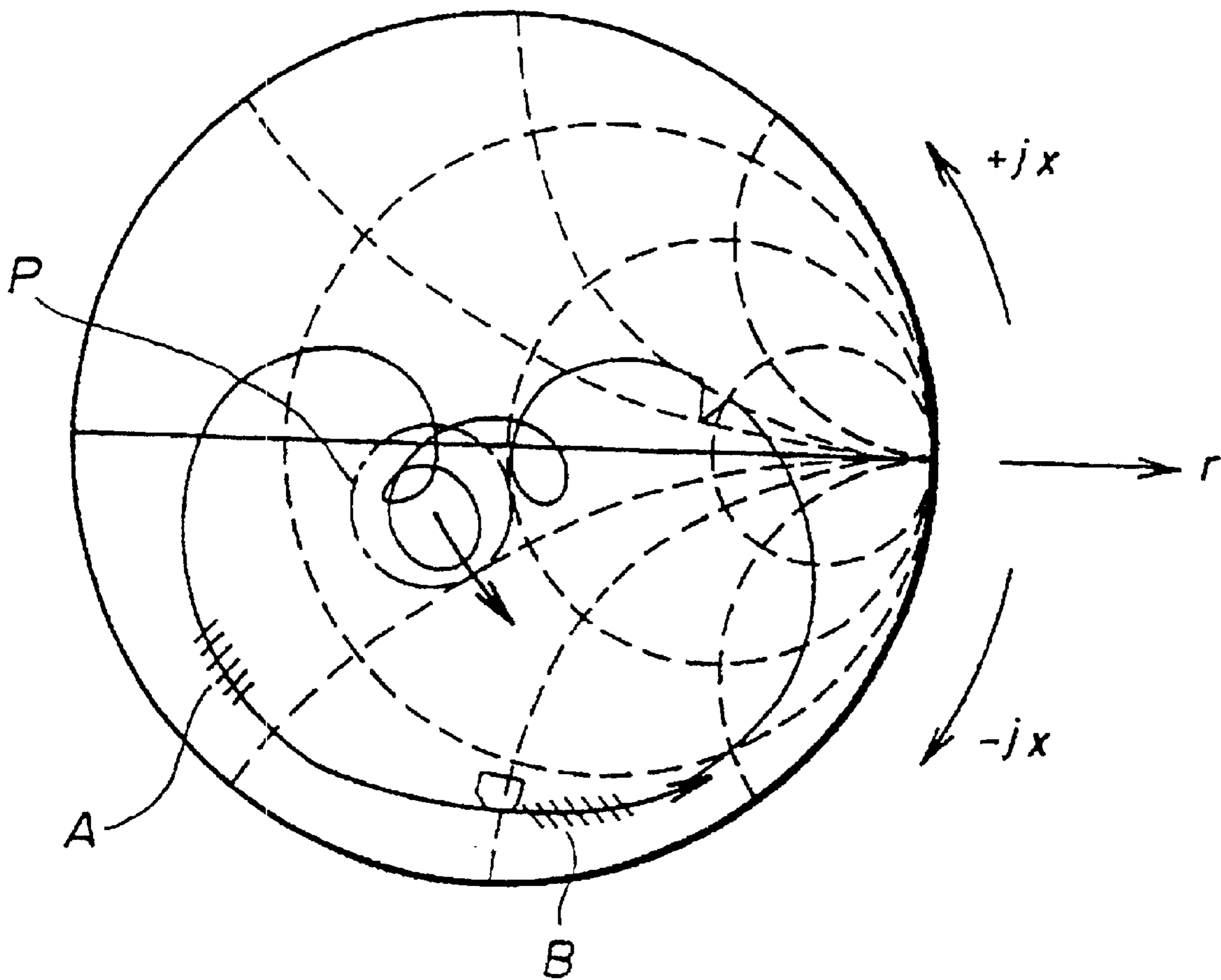

FIG. 78

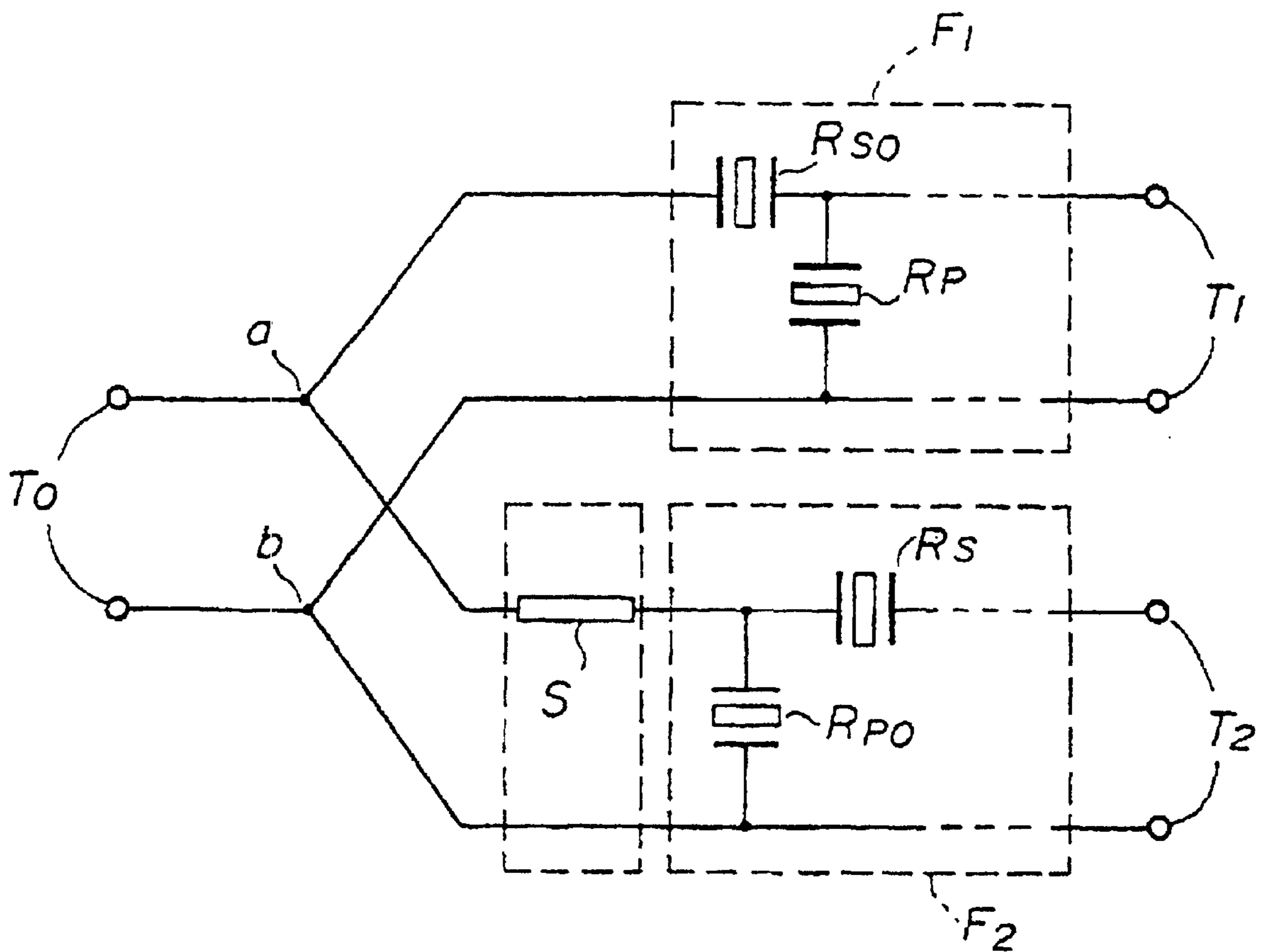
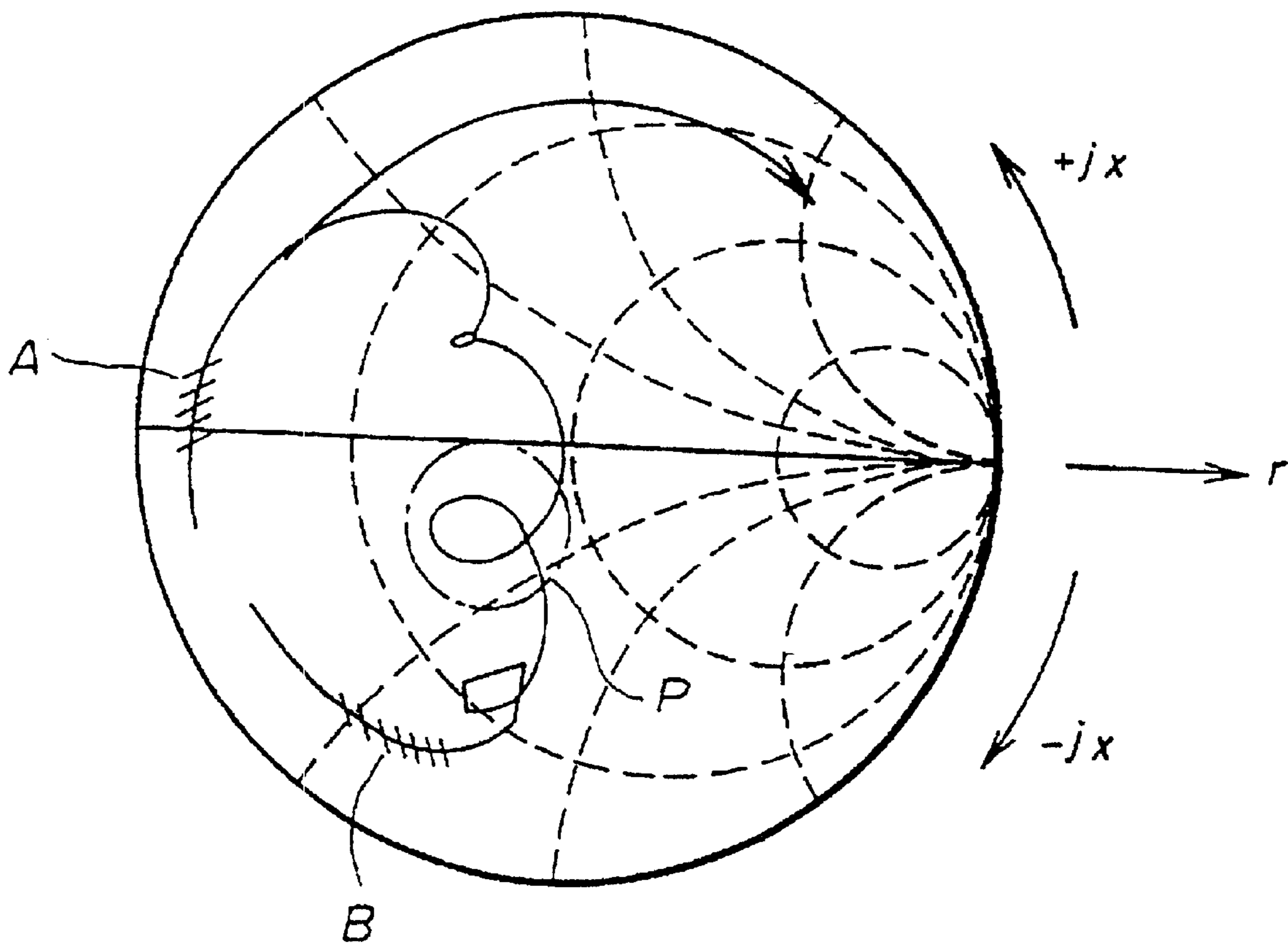

FIG. 79



SURFACE ACOUSTIC WAVE FILTER

Matter enclosed in heavy brackets [] appears in the original patent but forms no part of this reissue specification; matter printed in italics indicates the additions made by reissue.

CROSS REFERENCE TO RELATED APPLICATIONS

[This application is a continuation of application No. 07/965,774, filed Oct. 23, 1992, now U.S. Pat. No. 5,559,481, patented Sep. 24, 1996.] *This application and application Ser. No. 09/314,943, filed May 20, 1999 (now U.S. Pat. No. RE 37,790), are each reissues of U.S. Pat. No. 5,631,612 (application Ser. No. 08/369,492, filed Jan. 6, 1995). This application is a continuation of application Ser. No. 09/314,943, filed May 20, 1999, now U.S. Pat. No. RE 37,390, the contents of which are hereby incorporated by reference, which is a reissue of U.S. Pat. No. 5,631,612 (application Ser. No. 08/369,492, filed Jan. 6, 1995), which is a continuation of application Ser. No. 07/965,774, filed Oct. 23, 1992, now U.S. Pat. No. 5,559,481. This application is related to application Ser. No. 09/158,074, filed Sep. 22, 1998, now U.S. Pat. No. RE 37,375, which is a reissue of U.S. Pat. No. 5,559,481.*

BACKGROUND OF THE INVENTION

1. Field of the Invention

The present invention generally relates to surface acoustic wave (SAW) filters, and more particularly to a ladder-type SAW filter suitable for an RF (Radio Frequency) filter provided in pocket and mobile telephones, such as automobile phone sets and portable phones.

2. Description of the Prior Art

In Japan, an automobile phone or portable phone system has a specification in which a transmission frequency band is ± 8.5 MHz about a center frequency of 933.5 MHz. The ratio of the above transmission band to the center frequency is approximately 2%.

Recently, SAW filters have been employed in automobile phone or portable phone systems. It is required that the SAW filters have characteristics which satisfy the above specification. More specifically, it is required that the pass band width is so broad that 1) the ratio of the pass band to the center frequency is equal to or greater than 2%, 2) the insertion loss is small and equal to 5 dB–2 dB, and 3) the suppression factor is high and equal to 20 dB–30 dB.

In order to satisfy the above requirements, SAW filters are substituted for conventional transversal filters. Generally, SAW elements are so connected that a ladder-type filter serving as a resonator is formed.

FIG. 1 is an equivalent circuit of a SAW filter disclosed in Japanese Laid-Open Patent Publication No. 52-19044. A SAW filter 1 shown in FIG. 1 comprises a SAW resonator 3 in a series arm 2, and a SAW resonator 5 in a parallel arm 4. The equivalent parallel capacitance C_{OB} of the resonator 5 in the parallel arm 4 is larger than the equivalent parallel capacitance C_{OA} of the resonator 3 in the series arm 2.

The SAW filter 1 shown in FIG. 1 has a characteristic shown in FIG. 2. A curve 6 shows an attenuation quantity v. frequency characteristic of the SAW filter 1. As indicated by arrows 7 shown in FIG. 2, the suppression factor increases as the equivalent parallel capacitance C_{OB} increases. However, as the equivalent parallel capacitance C_{OB} increases, the band width decreases, as indicated by arrows

8, and the insertion loss increases, as indicated by an arrow 9. Hence, the characteristic deteriorates, as indicated by a broken line 10. When trying to obtain a suppression factor equal to or larger than 20 dB, the band width is decreased to that the ratio of the pass band to the center frequency is equal to or smaller than 1%, and does not satisfy the aforementioned specification of the 800 MHz-band radio systems.

SUMMARY OF THE INVENTION

It is a general object of the present invention to provide a SAW filter in which the above disadvantages are eliminated.

A more specific object of the present invention is to provide a SAW filter having a large band width, a large suppression factor, and a small insertion loss.

The above objects of the present invention are achieved by a SAW filter comprising: a first SAW resonator (21, R1A, R1B) having a pair of terminals and a predetermined resonance frequency (f_{rp}), the first SAW resonator being provided in a parallel arm (24) of the SAW filter; a second SAW resonator (23) having a pair of terminals and a predetermined resonance frequency (f_{rs}) approximately equal to the predetermined antiresonance frequency of the first SAW resonator (f_{ap}), the second SAW resonator being provided in a series arm (24) of the SAW filter; and an inductance element (25, L1) connected in series to the first SAW resonator.

BRIEF DESCRIPTION OF THE DRAWINGS

Other objects, features and advantages of the present invention will become more apparent from the following detailed description when read in conjunction with the accompanying drawings, in which:

FIG. 1 is an equivalent circuit diagram of a conventional SAW filter;

FIG. 2 is a graph of a characteristic of the conventional SAW filter shown in FIG. 1;

FIG. 3 is a circuit diagram of a SAW filter according to the present invention;

FIG. 4 is a block diagram of the basic structure of a filter circuit using a resonator;

FIGS. 5A, 5B and 5C are diagrams showing a one-terminal-pair SAW resonator;

FIGS. 6A and 6B are diagrams showing frequency characteristics of impedance and admittance of the one-terminal-pair SAW resonator;

FIGS. 7A to 7C are diagrams showing an immittance characteristic of a SAW resonator and a filter characteristic of the filter shown in FIG. 3 using that SAW resonator;

FIGS. 8A to 8C are diagrams showing the characteristics of the conventional SAW filter shown in FIG. 1;

FIGS. 9A and 9B are diagrams showing effects obtained when an inductance is connected in series to a resonator;

FIGS. 10A and 10B are diagrams showing effects obtained when n one-terminal-pair resonators are connected in series;

FIGS. 11A and 11B are diagrams showing an aperture length dependence on a parallel-arm resonator;

FIGS. 12A to 12C are diagrams showing an aperture length dependence on a series-arm resonator;

FIG. 13 is a circuit diagram of a SAW filter according to a first embodiment of the present invention;

FIG. 14 is a diagram showing a band characteristic of the filter shown in FIG. 13;

3

FIGS. 15A and 15B are diagrams showing effects obtained when an inductance is added to a parallel-arm resonator;

FIG. 16 is a plan view of the structure of the SAW filter shown in FIG. 13 with a lid removed therefrom;

FIG. 17 is a cross-sectional view taken along a line XVII—XVII shown in FIG. 16;

FIG. 18 is a diagram of a SAW filter according to a second embodiment of the present invention;

FIG. 19 is a diagram showing a band characteristic of the filter shown in FIG. 18;

FIGS. 20A and 20B are diagrams showing effects based on the ratio of the aperture length of the parallel-arm resonator to the aperture length of the series-arm resonator;

FIG. 21 is a diagram of a SAW filter according to a third embodiment of the present invention;

FIG. 22 is a diagram showing a band characteristic of the filter shown in FIG. 21;

FIG. 23 is a diagram of a SAW filter according to a fourth embodiment of the present invention;

FIG. 24 is a diagram showing a band characteristic of the filter shown in FIG. 23;

FIG. 25 is a circuit diagram of a SAW filter according to a fifth embodiment of the present invention;

FIG. 26 is a diagram showing a band characteristic of the filter shown in FIG. 25;

FIG. 27 is a circuit diagram of a SAW filter according to a sixth embodiment of the present invention;

FIG. 28 is a diagram showing a first one-terminal-pair SAW resonator shown in FIG. 27;

FIG. 29 is a diagram showing a band characteristic of the filter shown in FIG. 27;

FIG. 30 is a diagram showing the influence of the reflector setting position on the width of a ripple;

FIG. 31 is a plan view of the structure of the SAW filter shown in FIG. 27 with a lid removed therefrom;

FIG. 32 is a diagram showing a variation of the first one-terminal-pair SAW resonator shown in FIG. 27;

FIG. 33 is a diagram showing another variation of the first one-terminal-pair SAW resonator shown in FIG. 27;

FIG. 34 is a circuit diagram of a SAW filter according to a seventh embodiment of the present invention;

FIG. 35 is a diagram showing the relation between the film thickness of the electrode and the ripple occurrence position;

FIG. 36 is a diagram showing a state in which a ripple arising from reflectors of a parallel-arm resonator has been dropped into a high-frequency attenuation pole;

FIGS. 37A, 37B and 37C are diagrams showing a film thickness' dependence on the pass band characteristic of a resonator-type filter;

FIGS. 38A and 38B are diagrams showing the results of an experiment concerning the film thickness' dependence on the insertion loss and the ripple occurrence position;

FIG. 39 is a diagram of a first one-terminal-pair SAW resonator according to an eighth embodiment of the present invention;

FIG. 40 is a diagram showing a band characteristic of the SAW filter shown in FIG. 39;

FIG. 41 is a diagram showing a variation of the first one-terminal-pair SAW resonator used in the eighth embodiment of the present invention;

4

FIG. 42 is a plan view of a structure which realizes inductors used in the filter shown in FIG. 13;

FIG. 43 is a diagram of another structure which realizes inductors used in the filter shown in FIG. 13;

FIG. 44 is a circuit diagram of a SAW filter according to an eleventh embodiment of the present invention;

FIG. 45 is a perspective view of the SAW filter shown in FIG. 44;

FIGS. 46A and 46B are diagrams showing an immittance characteristic of a SAW resonator in which the resonance frequency is higher than the anti-resonance frequency;

FIGS. 47A, 47B and 47C are diagrams showing variations in the band characteristic of the ladder-type filter observed when the difference between the resonance frequency and the antiresonance frequency increases from zero;

FIGS. 48A and 48B are diagrams showing how to measure the characteristics of the SAW resonator;

FIG. 49 is a graph showing admittance and immittance characteristics of SAW resonators in the series arm and the parallel arm;

FIG. 50 is a diagram showing the frequency dependence on the product of bx ;

FIG. 51 is a diagram showing an equivalent circuit in which a part of the circuit shown in FIG. 44 is expressed by means of L and C ;

FIG. 52 is a diagram showing the relation between $|bx_{max}|$ and $\Delta f/f_{rs}$;

FIG. 53 is a diagram showing the relation between k^2 and τ ;

FIG. 54 is a circuit diagram of a SAW filter according to a twelfth embodiment of the present invention;

FIG. 55 is a perspective view of the SAW filter shown in FIG. 54;

FIG. 56 is a diagram showing a filter characteristic of the SAW resonator shown in FIG. 53;

FIG. 57 is a diagram showing a characteristic obtained when an output-side admittance of the filter shown in FIG. 64 is reduced;

FIGS. 58A and 58B are circuit diagrams of unit sections;

FIGS. 59A, 59B and 59C are circuit diagrams showing multi-connections of unit sections;

FIG. 60 is a diagram showing a connection of two four-terminal circuits and an interface therebetween;

FIGS. 61A, 61B and 61C are circuit diagrams showing unit section connecting ways;

FIG. 62 is a diagram showing how n unit sections are cascaded;

FIGS. 63A, 63B and 63C are circuit diagrams showing how ladder-type circuits are configured using the unit sections;

FIG. 64 is a circuit diagram of a [conventional] comparative example of the SAW filter;

FIG. 65 is a circuit diagram of a SAW filter according to a thirteenth embodiment of the present invention;

FIG. 66 is a circuit diagram of a SAW filter according to a fourteenth embodiment of the present invention;

FIG. 67 is a diagram showing a SAW filter according to a fifteenth embodiment of the present invention;

FIG. 68 is a perspective view of the SAW filter shown in FIG. 57;

FIG. 69 is a diagram showing a filter characteristic of the filter shown in FIG. 68;

5

FIG. 70 is a circuit diagram of a ladder-type filter in which SAW resonators having different resonance frequencies are respectively provided in the parallel and series arms;

FIGS. 71A and 71B are diagrams showing a frequency characteristic of the admittance of the parallel-arm resonator and a frequency characteristic of the impedance of the series-arm resonator;

FIG. 72 is a circuit diagram of a wave filter according to a sixteenth embodiment of the present invention;

FIG. 73 is a Smith's chart of the wave filter shown in FIG. 72;

FIG. 74 is a circuit diagram of a wave filter according to a seventeenth embodiment of the present invention;

FIG. 75 is a Smith's chart of the wave filter shown in FIG. 74;

FIG. 76 is a circuit diagram of a wave filter according to an eighteenth embodiment of the present invention;

FIG. 77 is a Smith's chart of the wave filter shown in FIG. 76;

FIG. 78 is a circuit diagram of a wave filter according to a nineteenth embodiment of the present invention; and

FIG. 79 is a Smith's chart of the wave filter shown in FIG. 78.

DESCRIPTION OF THE PREFERRED EMBODIMENTS

FIG. 3 shows an overview of a SAW filter 20 according to the present invention. The SAW filter 20 comprises a first SAW resonator 21 having a pair of terminals, a parallel arm 22, a second SAW resonator 23 having a pair of terminals, a series arm 24, and an inductor 25. The first resonator 21 connected to the parallel arm 22 has a predetermined resonance frequency f_{rp} . The second resonator 21 connected to the series arm 24 has a predetermined resonance frequency f_{rs} approximately equal to an antiresonance frequency f_{ap} of the first resonator 21. The inductor 25 is connected in series to the first resonator 21, and provided in the parallel arm 22.

The principle of the SAW filter 20 will now be described. Use of image parameters is convenient to verify whether or not a resonance circuit has a filter characteristic. The details of image parameters are described in the following document: Yanagisawa et al., "Theory and Design of Filters", Sanpo Shuppan, Electronics Sensho, pp. 192-pp. 203, 1974.

First of all, a basic ladder-type circuit having a filter characteristic will be described with reference to FIG. 4. Two black boxes 30 and 31 shown in FIG. 4 are respectively SAW resonators. For the sake of simplicity, it will now be assumed that the SAW resonators 30 and 31 are respectively reactance circuits having no resistance, and that the impedance Z of the resonator 30 provided in the series arm is equal to jx , and the admittance Y of the resonator 31 provided in the parallel arm is equal to jb .

According to the image parameter method, an image transfer quantity γ (a complex number) defined in the following equation has the important meaning:

$$\exp(\gamma) = \sqrt{V_1 \cdot I_p / V_2 \cdot I_2} \quad (1)$$

where V_1 and I_1 denote an input voltage and an input current, respectively, and V_2 and I_2 denote an output voltage

6

and an output current, respectively. The equation (1) can be rewritten as follows:

$$\begin{aligned} \tanh(\gamma) &= \tanh(\alpha + j\beta) \\ &= \sqrt{(B \cdot C) / (A \cdot D)} \end{aligned} \quad (2)$$

where A, B, C and D denote parameters of an F matrix showing the whole circuit shown in FIG. 4. When the value expressed by the equation (2) is an imaginary number, the two-terminal-pair circuit shown in FIG. 4 has a pass band characteristic. With the above value being a real number, the circuit shown in FIG. 4 has an attenuation characteristic. The ABCD parameters can be rewritten using the above-mentioned x and b :

$$\begin{aligned} A &= 1 \\ B &= jx \\ C &= jb \\ D &= 1 - bx \end{aligned} \quad (3).$$

Hence, the following equation (4) can be obtained from the equation (2) using the above ABCD parameters:

$$\tanh(\gamma) = \sqrt{bx / (bx - 1)}. \quad (4)$$

When $0 < bx < 1$, that is, when b and x have the same sign and are small values, the entire circuit shown in FIG. 4 has a pass band characteristic. When $bx < 0$ or $bx > 1$, that is, when the b and x have different signs or the product of bx is a large value, the circuit shown in FIG. 4 has an attenuation characteristic.

In order to qualitatively understand the frequency characteristics of b and x , the impedance and admittance of the SAW resonators will not be considered.

As shown in FIG. 5A, a SAW resonator having pair of terminals comprises an interdigital electrode 40 (see "Nikkel Electronics", November 29, pp.76-pp.98, 1976). A reference number 41 indicates a pair of electrodes, 42 indicates an aperture length (crossing width), and 43 indicates an interdigital electrode period. When the resistance of the interdigital electrode 40 is neglected, the SAW resonator shown in FIG. 5A has an equivalent circuit 45 shown in FIG. 8B, in which C_0 denotes the electrostatic capacitance of the interdigital electrode 40, C_1 and L_1 denote equivalent constants. Hereinafter, the equivalent circuit 45 is depicted by symbol 46 shown in FIG. 5C.

FIGS. 6A and 6B qualitatively show an impedance vs. frequency characteristic (A) of the equivalent circuit shown in FIG. 5B, and an admittance vs. frequency characteristic (B) thereof. The characteristics shown in FIGS. 6A and 6B are double resonance characteristics in which two resonance frequencies f_r and f_a exist. It will be noted that a resonator having a crystal has a double resonance characteristic. When the resonators respectively having a double resonance characteristic are arranged in the series and parallel arms, respectively, and an antiresonance frequency f_{ap} of the parallel arm is made approximately equal to a resonance frequency f_{rs} of the series arm, a circuit can be configured which has a band-pass-type filter characteristic having the center frequencies f_{ap} and f_{rs} . This is because, as shown in an immittance vs. frequency characteristic shown in FIG. 7A, the relation $0 < bx < 1$ is satisfied in a frequency range

around the center frequency $f_{ap} \approx f_{rs}$ and that frequency range is a pass band, while the relation $bx > 1$ is satisfied in a frequency range slightly away from the center frequency and the relation $bx < 0$ is satisfied in a frequency range far away from the center frequency, the latter two frequency ranges serving as attenuation bands. Hence, the SAW filter shown in FIG. 4 has a qualitative filter characteristic 47 shown in FIG. 7B.

A description will now be given of the factors that determine the band width in the resonator-type SAW filters. As is seen from FIGS. 7A and 7B, the band width is mainly dependent on the difference between the resonance frequency f_r and the antiresonance frequency f_a of each of the two resonators. The band width increases as the above difference increases, while the band width decreases as the difference decreases. The resonance frequency f_r and the antiresonance frequency f_a can be determined using the following equations, using the equivalent circuit constants shown in FIG. 5B:

$$f_r = 1 / [2 \cdot \pi \sqrt{(C_1 \times L_1)}] \quad (5)$$

$$f_a = f_r \cdot \sqrt{(1 + 1/\tau)} \quad (6)$$

$$\tau = C_0 / C_1 \quad (7)$$

where τ denotes the capacitance ratio. The ratio of the pass band to the center frequency ($\Delta f / f_o$) is mainly dependent on the difference between f_r and f_a , and is therefore expressed in the following expression, using the equations (6) and (7):

$$\Delta f / f_o = 2(f_a - f_r) / (f_a + f_r) = 2 / (4\tau + 1) \quad (8)$$

It can be seen from the equation (8) that the capacitance ratio τ is the main factor which determines the ratio of the pass band to the center frequency. However, as set forth in Japanese Laid-Open Patent Publication No. 52-19044, the capacitance ratio is much dependent on the type of substrate material used for the interdigital electrode. For example, an ST-cut crystal having a small electromechanical coupling coefficient has a capacitance ratio τ equal to or greater than 1300, while a 36° Y-cut X-propagation LiTaO₃ substrate having a large electromechanical coupling coefficient has a capacitance ratio τ of approximately 15. The ratio of the pass band to the center frequency is 0.04% for ST-cut crystal, and 3.3% for the 36° Y-cut X-propagation LiTaO₃ substrate. Hence, the band width is much dependent on the substrate material.

The band width decreases as the equivalent parallel capacitance C_{OB} increases in order to improve the side lobe suppression factor according to Japanese Laid-Open Patent Publication No. 52-19044.

The above phenomenon will now be described with reference to FIGS. 8A, 8B and 8C. As is seen from the previous description of the principle of the present invention, as the admittance value increases while f_r and f_a of the parallel resonator (see, FIG. 8C) are kept constant, the product of bx has a negative sign and increases, as shown in FIG. 8A. However, the bx product increases around the center frequency, and hence the range of $bx > 1$ increases. Hence, the pass band in which the relation $0 < bx < 1$ stands is narrowed, and a sufficient pass band cannot be obtained. This phenomenon is indicated by arrows in FIG. 8B.

The following two conditions must be satisfied in order to eliminate the above disadvantages. The first condition is to increase the difference between the resonance frequency f_r and the antiresonance frequency f_a in at least one of the

resonators provided in the series and parallel arms (see FIG. 8C). The second condition is to increase either the impedance or admittance of the above-mentioned one of the resonators. As the impedance or admittance increases, the side lobe attenuation quantity increases. When the above two conditions are satisfied, the side lobe attenuation quantity can be improved while the pass band is improved or prevented from being narrowed.

Regarding the first condition, it is effective to provide an inductor L connected in series to a SAW resonator having a pair of terminals in order to increase the difference between f_r and f_a . FIGS. 9A and 9B respectively show an impedance vs. frequency characteristic of a SAW filter in which an inductor having an inductance of 8 nH is connected to a resonator, and an admittance vs. frequency characteristic thereof. The parameters of the equivalent circuits of the SAW resonators used for obtaining the characteristics are illustrated in FIGS. 9A and 9B.

FIG. 9A shows an impedance characteristic curve 50 obtained before the inductor L is connected to the resonator, and an impedance characteristic curve 51 obtained after the inductor is connected thereto. FIG. 9B shows an admittance characteristic curve 52 obtained before the inductor L is connected to the resonator, and an admittance characteristic curve 53 obtained after the inductor L is connected thereto.

It can be seen from FIG. 9A that the inductance L increases the distance between the resonance frequency f_r and the antiresonance frequency f_a . In the graph of FIG. 9A, the distance is increased by approximately 30 MHz. This is because, as shown in FIG. 9A, the inductance L functions to shift the impedance characteristic curve of the original resonator upwards to the plus side by ωL , and hence the resonance frequency f_r changes to f_r' . In this case, the antiresonance frequency f_a has little variation. The admittance, which is the reciprocal of the impedance, changes, as shown in FIG. 9B. In this case, the resonance frequency f_r changes to f_r' .

Regarding the aforementioned second condition, the admittance value increases due to the inductance L , as shown in FIG. 9B. However, as shown in FIG. 9A, the impedance value decreases in frequencies outside of the pass band. Hence, if the inductance L is added to the resonator provided in the series arm, it is necessary to provide an additional means for increasing the impedance value. The above additional means is, for example, an arrangement in which a plurality of identical SAW resonators are connected in series to each other (cascaded).

FIGS. 10A and 10B show an impedance characteristic curve 56 of a resonance arrangement in which n identical SAW resonators, each having a pair of terminals, are cascaded. As shown in FIGS. 10A and 10B, the impedance value of the resonance arrangement having the n cascaded resonators is n times that of the single resonator. The resonance frequency of the resonator with the inductor L connected thereto is f_r'' . That is, the difference between f_r'' and f_a of the resonance arrangement with the inductor L connected thereto is slightly smaller than the difference between f_r' and f_a of a single resonator with the inductor L connected thereto. However, the difference between f_r'' and f_a of the resonance arrangement with the inductor L connected thereto is larger than that without the inductor L . It is possible to further increase the difference between the resonance frequency and the antiresonance frequency by using a larger inductance L .

In order to increase the band width, it is also possible to select the antiresonance frequency f_{ap} of the parallel arm resonator and the resonance frequency f_{rs} of the series arm

resonator so that $f_{rs} > f_{ap}$. In this case, the condition $bx < 0$ occurs around the center frequency, and hence the aforementioned pass band condition is not satisfied. Hence, there is a possibility that an insertion loss and a ripple may increase. However, by controlling $\Delta f = f_{vs} - f_{ap}$, it is possible to substantially suppress the increase in the insertion loss and the ripple and to expand the increase in the pass band.

A description will now be given of embodiments of the present invention. The embodiments which will be described are based on a simulation. Hence, this simulation will be described first, as well as the results of comparisons between the experimental results and the simulation in order to show the validity of the simulation.

The equivalent circuit shown in FIG. 5B easily simulates the characteristic of the SAW resonator having a pair of terminals, while that equivalent circuit is not suitable for simulating, with high accuracy, variations in the number of finger pairs, the aperture length and the electrode thickness, and the effects of a reflector. With the above in mind, the inventors have proposed an improved simulation which uses a Smith's equivalent circuit model and expands a transfer matrix to analyze the SAW resonators (see O. Ikata et al., "1990 ULTRASONIC SYMPOSIUM Proceedings, vol. 1, pp.83-pp.86, 1990; the disclosure of which is hereby incorporated by reference).

FIG. 11A is a graph showing the results of the simulation (calculation) for an arrangement in which a SAW resonator having a pair of terminals is disposed in the parallel arm. FIG. 11B is a graph showing the results of the experiment on an arrangement in which a one-terminal-pair SAW resonator including an interdigital electrode made of Al-2% Cu and having a film thickness of 1600 Å is disposed in a parallel arm, and bonding wires ($L=1.5$ nH) having a length of 3 mm are connected to the interdigital electrode. It can be seen from FIGS. 11A and 11B that the calculation values match the experiment values with respect to variations in the resonance points (f_{r1} , f_{r2} , f_{r3}) as well as the attenuation quantities observed around the resonance points for different aperture lengths ($a=60, 150, 300$ μm).

FIG. 12A is a graph showing the results of the simulation for an arrangement in which a SAW resonator having a pair of terminals is disposed in the series arm (see, FIG. 12C). The bonding pads used in the experiment which will be described later were slightly large, and the simulation was carried out taking into account a stray capacitance 0.5 pF of the bonding pads. FIG. 12B is a graph showing the results of the experiment on an arrangement in which a SAW resonator having a pair of terminals is disposed in the series arm. It can be seen from FIGS. 12A, 12B and 12C that the antiresonance frequencies f_{a1} , f_{a2} and f_{a3} do not depend on the aperture length and that the simulation results match the experimental results regarding variations in the attenuation quantity around the resonance frequencies.

Hence, it will be apparent from the above that the results of a simulation of the filter with the combination of the resonators disposed in the parallel and series arms match the results of the experiment. The embodiments described below are based on the result of simulations.

FIG. 13 shows a SAW filter 60 according to a first embodiment of the present invention. In Japan, an automobile and portable telephone system has a specification in which the ± 8.5 MHz range about a center frequency of 933.5 MHz is a transmission band for mobile telephones and the ± 8.5 MHz range about a center frequency of 878.5 MHz separated from 933.5 MHz by -55 MHz is a [rejection] rejection band. The SAW filter 60 according to the first embodiment of the present invention is designed to be suitable for transmission filters of mobile telephones.

As shown in FIG. 13, two one-terminal-pair SAW resonators R2 and R4 are arranged in a series arm 61, and three one-terminal-pair SAW resonators R1, R3 and R5 are respectively arranged in parallel arms 62, 63 and 64. Inductors L1, L2 and L3 are provided in the parallel arms 62, 63 and 64, and are connected in series to the resonators R1, R3 and R5, respectively. Each of the resonators R1-R5 has the interdigital electrode structure shown in FIG. 5A. The number of finger pairs is 100, and the aperture length is 80 μm. The electrodes are made of Al-2% Cu, and are 3000 Å thick. The resonance frequencies of the resonators R1, R3 and R5 respectively provided in the parallel arms 62, 63 and 64 are 912 MHz, and the antiresonance frequencies thereof are 934 MHz. The resonance frequencies of the resonators R2 and R4 respectively provided in the series arm 61 are 934 MHz, and the antiresonance frequencies thereof are 962 MHz. The inductors L1, L2 and L3 respectively have an inductance L of 4 nH.

The SAW filter 60 having the above structure has a band characteristic indicated by a curve 65 shown in FIG. 14. Characteristic curves 66 and 67 in FIG. 14 are respectively obtained when the inductance L is equal to 2 nH and 6 nH.

A curve 70 shown in FIG. 15A illustrates the inductance' dependence on the band width obtained on the basis of the graphs of FIG. 14. The band width is defined as the frequency width between the points on the curve where the insertion loss is 3 dB greater than the minimum value.

A curve 71 shown in FIG. 15B illustrates a side lobe suppression factor' dependence on the inductance obtained on the basis of the graphs of FIG. 14. It can be seen from FIG. 14 that a sufficient suppression factor is not obtained at a frequency which is 55 MHz lower than the center frequency when the inductance L is too large. With the above in mind, an inductance L of 4 nH is selected. The value of the inductance L is suitable selected in accordance with the specification of filters.

A curve 68 in FIG. 14 shows a band characteristic of a configuration in which $L1=L2=L3=0$ in FIG. 13. It can be seen from comparison between the band characteristic (curve 65) of the first embodiment and that (curve 68) of the conventional filter that the filter 60 according to the first embodiment has a large pass band width (arrow 75), a large side lobe suppression factor (arrows 76), and a low insertion loss (arrow 77).

FIGS. 16 and 17 show a SAW filter device 80 which functions as the SAW filter 60 shown in FIG. 13. The SAW filter device 80 comprises a ceramic package 81, a filter chip 82, and a lid 83 serving as the ground. The ceramic package 81 is made of alumina ceramics, and has dimensions of 5.5 mm (length)×4 mm (width)×1.5 mm (height). Electrode terminals 84₋₁-84₋₆ made of Au are formed on the ceramic package 81. The filter chip 82 is made of LiTaO₃, and has dimensions of 2 mm (length)×1.55 mm (width)×0.5 mm (thickness).

Resonators R1-R5 are arranged on the filter chip 82 so that each of the resonators R1-R5 does not own propagation paths in common with other resonators. Each of the resonators R1-R5 has an interdigital electrode made of Al-2% Cu in which the number of finger pairs is 100, the aperture length is 80 μm, and the film thickness is 3000 Å.

Further, two signal line terminals 85₋₁ and 85₋₂ for bonding and three ground terminals 85₋₃, 85₋₄ and 85₋₅ for bonding are formed on the surface of the filter chip 82. Reference numbers 86₋₁-86₋₅ indicate bonding wires made of Al or Au. The bonding wires 86₋₁-86₋₅, each having a diameter of 25 μm ϕ , connects the terminals 84₋₁-84₋₅ and the terminals 85₋₁-85₋₅. The bonding wires 86₋₁ and 86₋₂

respectively form parts; of the series arms 61a and 61b. The wire 86₋₃ is connected between the ground electrode terminals 84₋₃ and 85₋₃, and the wire 86₋₄ is connected between the ground electrode terminal 84₋₄ and 85₋₄. The wire 86₋₅ is connected between the ground electrode terminals 84₋₅ and 85₋₅. The wires 86₋₃–86₋₅ are long and, for example, 2.0 mm long.

According to the theory of high frequencies, a fine, long wire has an inductance component. According to the theoretical equation of a ribbon inductor located in a space (see Kurashi, "Exercise Microwave Circuit", Tokyo Denki Daigaku Shuppan-Kyoku, pp. 199), the inductances of the wires 86₋₃, 86₋₄ and 86₋₅ are approximately equal to 1 nH. [It] If the high attenuation and wide pass band are needed, it is insufficient to obtain an inductance of 4 nH by means of only the wires. As will be described later, inductors are formed on the ceramic package 81 and the filter chip 82. In this manner, the inductors L1, L2 and L3 are formed.

A description will now be given of a SAW filter according to a second embodiment of the present invention. FIG. 18 shows a SAW filter 90 according to the second embodiment of the present invention. In FIG. 18, parts that are the same as parts shown in the previously described figures are given the same reference numbers. The resonator R2 in the series arm 61 has an aperture length A_s of 80 μm . A resonator and the inductor L1 connected in series to each other are provided in the parallel arm 62. The resonator R1A has an aperture length A_p of 120 μm . The aperture length A_p is larger than the aperture length A_s , being 1.5 times the aperture length A_s . The numbers N_p and N_s of finger pairs of the resonators R2 and R1A are 100.

The filter 90 shown in FIG. 19 has a band characteristic indicated by a curve 91 shown in FIG. 19. It can be seen from comparison between the curve 91 and the characteristic curve 65 of the filter 60 that the filter 90 has an improved side lobe suppression factor without a change in the pass band width.

FIGS. 20A and 20B show a band characteristic' dependence on the aperture length in the filter shown in FIG. 18. More particularly, FIG. 20A shows a curve 92 indicating the dependence on the aperture length with an inductance L of 4 nH connected to the resonator, and a curve 93 indicating the dependence on the aperture length without any inductance. The horizontal axis of FIG. 20A denotes the ratio A_p/A_s , and the vertical axis thereof denotes the side lobe suppression factor (dB). FIG. 20B shows a pass band width s the ratio A_p/A_s characteristic. A curve 95 indicates the dependence on inductance with an inductance L of 4 nH connected to the resonator, and a curve 96 indicates the dependence on inductance without any inductance.

The following can be seen from FIGS. 20A and 20B. First, the side lobe suppression factor increases when making the aperture length A_p of the resonator R1A in the parallel arm 62 larger than the aperture length A_s of the resonator R2 in the series arm 61. Second, the effect of the aperture length A_p of the resonator R1A is increased without deterioration of the pass band width by providing the inductor L1 in the parallel arm 62. It can be seen from the above that the filter 90 has an improved side lobe suppression factor while the pass band width is not narrowed, as compared to the filter 60.

A description will now be given of a third embodiment of the present invention with reference to FIG. 21, in which parts that are the same as parts shown in the previously described figures are given the same reference numbers. A SAW filter 100 shown in FIG. 21 comprises a resonator R1B provided in the parallel arm 62, and the resonator R2

provided in the series arm 61. The number N_s of finger pairs of the resonator R2 is 100. The inductor L1 is connected in series of the resonator R1B. The number N_p of finger pairs of the resonator R1B is 150, and is 1.5 times the number N_s of finger pairs. The aperture lengths A_s and A_p of the resonators R2 and R1A are 80 μm .

The filter 100 shown in FIG. 21 has a band characteristic indicated by a curve 101 shown in FIG. 22. It can be seen from comparison between the band characteristic curve 65 of the filter 60 and the characteristic curve 101 of the filter 100 that the filter 100 has an improved side lobe suppression factor indicated by arrows 102 without reducing the pass band width. It can also be seen from comparison between the band characteristic curve 91 of the filter 90 and the characteristic curve 101 that the insertion loss of the filter 100 is less than that of the filter 90. Hence, the filter 100 has an improved side lobe suppression factor while the pass band width is reduced, and has an insertion loss smaller than that of the filter 90.

A description will now be given of a fourth embodiment of the present invention with reference to FIG. 23, in which parts that are the same as parts shown in the previously described figures are given the same reference numbers. A filter 110 according to the fourth embodiment is intended to increase the difference between the resonance frequency f_r and the antiresonance frequency f_a of the resonator in the series arm and to thereby improve the band characteristic. Two identical resonators R2 are provided in the series arm 61, and two identical resonators R4 are provided therein. An inductor L_s having an inductance of 3 nH is connected in series to the resonators R2, and another inductor L_s having an inductance of 3 nH is connected in series to the resonators R4. The resonators R1, R3 and R5 are respectively provided in the parallel arms 62, 63 and 64. The filter 110 has a band characteristic indicated by a curve 111 shown in FIG. 24.

A description will now be given of the effects provided by adding one inductor L_s and two resonators R2 and R4. When one inductor L_s and two resonators R2 and R4 are omitted from the filter 110, the remaining circuit configuration consists of five resonators R1, R2, R3, R4 and R5. The band characteristic of the remaining circuit configuration is indicated by a curve 68 (see FIG. 14). By adding one inductor L_s , the pass band width is increased, as indicated by arrows 112 and the side lobe suppression factor is also increased, as indicated by arrows 113. Particularly, the pass band width is large at frequencies higher than the center frequency, and is increased by approximately 15 MHz. The band characteristic with the inductor L_s added to the conventional filter 1 is indicated by curve 114. In this case, a sufficient side lobe suppression factor is not obtained. Hence, two resonators R2 and R4 are further added to the conventional filter 1 with the inductor L_s added thereto. As indicated by arrows 115, the side lobe suppression factor is improved by approximately 5 dB without reducing the band characteristic, and a band characteristic curve 111 can be obtained. It can be seen from comparison between the curves 111 and 68 that the insertion loss is also improved, as indicated by arrows 116. It is possible to use more than two resonators R2 and more than two resonators R4. Further, as indicated by the two-dot chained line in FIG. 23, inductors can be provided in the parallel arms 62–64.

A description will now be given of a fifth embodiment of the present invention with reference to FIG. 25, in which parts that are the same as parts shown in the previously described figures are given the same reference numbers. A SAW filter 120 shown in FIG. 25 comprises five resonators R1–R5, and three inductors L1–L3. The inductor L1 in the

13

parallel arm **62** has an inductance L_{p1} of 4 nH, and the inductor $L2$ in the parallel arm **63** has an inductance L_{p2} of 5.5 nH. Further, the inductor $L3$ in the parallel arm **64** has an inductance L_{p3} of 7 nH.

By making the inductors $L1$, $L2$ and $L3$ have different inductance values, the filter **120** has a band characteristic indicated by a curve **121** shown in FIG. **26**. Let us compare the characteristic curve **121** with the characteristic curve **65** (FIG. **14**) of the filter **60** shown in FIG. **13** in which all the inductance values are the same as each other. It can be seen from the above that the filter **120** has an improved side lobe characteristic without reducing the pass band width, as compared to the filter **60**. The characteristic curve has an attenuation pole **123** located around a frequency of 902 MHz, while the characteristic curve **121** has two attenuation poles **124** and **125** respectively located around 875 MHz and 892 MHz. A frequency band **126** between the poles **124** and **125** functions as a blocking range **127**.

A description will now be given of a sixth embodiment of the present invention with reference to FIG. **27**, in which parts that are the same as parts shown in the previously described figures are given the same reference numbers. A SAW filter **130** shown in FIG. **27** comprises two SAW resonators $R2$ and $R4$ provided in the series arm **61**, and three SAW resonators $R1B$, $R3B$ and $R5B$ respectively provided in the parallel arms **63** and **64**.

As shown in FIG. **28**, the resonator $R1B$ has an exciting interdigital electrode **131**, and reflectors **132** and **133** respectively disposed on both sides of the electrode **131**. The reflectors **132** and **133** are positioned so that $\beta=0.4$ in which β is obtained from the following equation:

$$d=(n+\beta)\lambda$$

where d is the distance between the center of the electrode **131** and each of the reflectors **132** and **133**, n is an arbitrary integer, β is a real number equal to or less than 1, and λ is the period of the interdigital electrode **131** corresponding to its resonance frequency.

The number of finger pairs of each of the reflectors **132** and **133** is 50. The resonators respectively equipped with the reflectors are indicated by the symbol "*" shown in FIG. **27**. The resonators $R3B$ and $R5B$ respectively provided in the parallel arms **63** and **64** respectively have two reflectors in the same manner as the resonator $R1B$.

The filter **130** shown in FIG. **27** has a band characteristic indicated by a curve **134** shown in FIG. **29**. As compared to the characteristic curve **85** of the filter **80** (FIG. **13**), the insertion loss in the filter **130** is improved, as indicated by an arrow **135**. A ripple r_p arises from the arrangement of the reflectors **132** and **133**.

A description will now be given of the reason why the reflectors **132** and **133** are arranged in the above-mentioned manner. The influence of the ripple r_p observed when β is changed from 0 to 0.5 is illustrated by a curve **140** shown in FIG. **30**. The smallest ripple width can be obtained at a point **141** at which β is 0.4.

FIG. **31** shows a SAW filter device **150** functioning as the filter **130** shown in FIG. **27**. In FIG. **31**, parts that are the same as parts shown in the previously described figures are given the same reference numbers as previously. The filter device **150** comprises reflectors **132**, **133**, **151**, **152**, **153** and **154**.

Variations of the one-terminal-pair SAW resonators $R1B$, $R3B$ and $R5B$ will now be described.

FIG. **32** shows a first variation $R1Ba$, which comprises interdigital electrodes **180** and respectively arranged on both

14

sides of the exciting interdigital electrode **131**. Each of the interdigital electrodes **180** and **181**, which functions as a reflector, is an electrode in which the electric load thereof is of a short-circuit type.

FIG. **33** shows a second variation $R1Bb$, which comprises strip array type electrodes **167** and **166** respectively arranged on both sides of the electrode **131**.

A description will now be given of a seventh embodiment of the present invention with reference to FIG. **34**, in which parts that are the same as parts shown in the previously described figures are given the same reference numbers. A SAW filter **170** shown in FIG. **34** comprises two SAW resonators $R2$ and two resonators $R4$ respectively provided in the series arm **61**, and three SAW resonators $R1B$, $R3B$ and $R5B$ respectively provided in the parallel arms **62**, **63** and **64**. Two inductors Ls are provided in the series arm **61**, as shown in FIG. **34**.

The filter **170** is obtained by replacing the resonators $R1$, $R3$ and $R5$ shown in FIG. **23** with the resonators $R1B$, $R3B$ and $R5B$ shown in FIG. **28**. As has been described previously, the reflectors **132** and **133** shown in FIG. **28** are positioned so that the condition $\beta=0.4$ is satisfied. The filter **170** has a loss of the pass band smaller than that of the filter **110** shown in FIG. **23**, and a suppressed ripple.

A description will now be given of an eighth embodiment of the present invention, which is intended to eliminate the ripple r_p shown in FIG. **29**. First of all, a means for effectively eliminating the ripple r_p arising from the reflectors will be described.

The inventors simulated the relationship between the frequencies at which the ripple r_p is observed and the electrode thickness. In the simulation, the effects resulting from increasing the film thickness of the electrode are replaced by increasing the ratio between the acoustic impedance (Z_m) obtained under the electrode and the acoustic impedance (Z_o) of the free surface. As described in the aforementioned Ikata document, an increase in the electrode thickness increases the weight thereof. Hence, it is possible to consider that an increase in the electrode thickness is proportional to an increase in a discontinuous quantity of the acoustic impedance. With the above in mind, the following equation was prepared:

$$Q=Z_o/Z_m=V_o/V_m=1+k^2/2+\alpha(t) \quad (9)$$

where V_o and V_m respectively denote sound velocities on the free surface and under the electrode, k^2 is the electromechanical coupling coefficient, and t is the film thickness of the electrode. Then $\alpha(t)$ was changed as a parameter proportional to the film thickness t .

From the equation (9), the center frequency f_o of the filter is written as follows:

$$f_o=2f_o'/(1+Q) \quad (10).$$

The equation (10) is consistent with the well-known experimental result in which, as the film thickness increases, the center frequency decreases from the center frequency f_o' obtained when there is no discontinuity of the acoustic impedance. The results of the simulation show that, as $\alpha(t)$ increases, that is, the film thickness increases, the frequency position at which the ripple r_p appears shifts toward the high-frequency range of the pass band, as indicated by an arrow **180** shown in FIG. **35**, and finally drops into the attenuation pole on the high-frequency side of the pass band. It will be noted that a ripple r_s shown in FIG. **35** is caused by the reflectors of the resonators provided in the series arm.

FIG. 36 shows an attenuation quantity vs. frequency characteristic obtained when $\alpha(t)=0.05$. A ripple resulting from the reflectors of the resonators in the parallel arms is located in the attenuation pole on the high-frequency side of the pass band. That is, there is no ripple in the pass band. In addition, the graph of FIG. 36 shows that the insertion loss is very small. In FIG. 36, the resonance frequencies of the resonators in the parallel and series arms are calibrated so that they are located at the frequency position which is 15 MHz higher than the original frequency position in order to obtain a center frequency of 932 MHz, because the center frequency of the pass band decreases according to the equation (10).

The inventors fabricated chips and measured the band characteristic thereof in order to study the relation to the actual film thickness.

FIGS. 37A, 37B and 37C respectively show band characteristic curves 185, 186 and 187 for film thicknesses of 2000 Å, 3000 Å and 4000 Å. In practice, the center frequency is varied by changing the film thickness. The graphs of FIGS. 37A, 37B and 37C have been calibrated by changing the period of the interdigital electrode.

A ripple r_p resulting from the resonators in the parallel arms is superimposed on the characteristic curve 185 for a film thickness of 2000 Å. As the film thickness increases, the ripple r_p shifts to higher frequencies. The experimental results shown in FIGS. 37A, 37B and 37C are consistent with the aforementioned results of the simulation.

However, an insertion loss arising from a bulk wave, which cannot be calculated by simulation, and a resistance loss appear as the film thickness increases (see Ebata et al., "SURFACE ACOUSTIC WAVE RESONATOR ON LiTaO₃ SUBSTRATE AND ITS APPLICATION TO OSCILLATORS FOR USE IN VTR", Journal of the Institute of Electronics and Communication Engineers of Japan, vol. J66-C, No.1, pp.23–pp.30, 1988). Further, the correlation between the above insertion loss and the resistance loss is also a very important factor.

FIG. 38A shows a curve 190 of the insertion loss resulting from the bulk wave, and a resistance loss curve 191. A curve 192 shows an experimental characteristic curve. The insertion loss is approximately equal to the resistance loss when the film thickness is 2500 Å. Then, the total loss mainly resulting from the insertion loss starts to increase when the film thickness is approximately 3500 Å.

A curve 193 shown in FIG. 38B indicates the frequency position f_{rp} of the ripple r_p as a function of the identical film thickness of the exciting electrode 131 and the reflectors 132 and 133 shown in FIG. 28. It is concluded, based on the graphs in FIGS. 38A and 38B of FIG. 38, that the optimum film thickness that results in no ripple and little insertion loss is between 2600 Å and 4000 Å. The above optimum film thickness can be normalized by the period λ_p (4.4 μm at 932 MHz see FIG. 28) of the resonators in the parallel arm substantially determined by the center frequency of the filter. The normalized optimum film thickness is between 0.06 and 0.09.

The eighth embodiment of the present invention is based on the results of the above consideration by the inventors.

FIG. 39 shows a first one-terminal-pair SAW resonator 200 used in the SAW filter according to the eighth embodiment. The resonator 200 comprises an exciting electrode 201, and two reflectors 202 and 203 respectively located on both sides of the electrode 201. The electrode 201 and the reflectors 202 and 203 are made of aluminum (Al) or a mixture or alloy of Al and a few percentage of other metal by weight. The film thickness t_1 of each of the electrodes and

the reflectors 202 and 203 is equal to 0.06–0.09 times the electrode period λ_p . A SAW filter, in which the resonator 200 is applied to each of the resonators R1B, R3B and R5B shown in FIGS. 27 and FIG. 34, has a band characteristic indicated by a curve 205 shown in FIG. 40. It can be seen from FIG. 40 that there is no ripple in the pass band. Use of an Al alloy improves the breakdown power performance, as compared to use of Al, Cu or Ti can be mixed with Al.

FIG. 41 shows a variation 210 of the SAW resonator 200. The resonator 210 shown in FIG. 41 comprises an exciting interdigital electrode 211, and two reflectors 212 and 213 respectively located on both sides of the electrode 211. The electrode 211 and the reflectors 212 and 213 are made of Au. The optimum film thickness of the electrode 211 and the reflectors 212 and 213 is determined, taking into account the above-mentioned phenomenon caused due to the influence of an increase in the weights of the electrode 211 and the reflectors 212 and 213. Since the ratio of the density of Al to that of Au is 2.7/18.9, equal to 0.143, the optimum film thickness t_2 is determined by multiplying the optimum film thickness t_1 by 0.143, and is equal to 0.0086–0.013 times the electrode period λ_p . A SAW filter obtained by applying the resonator 210 to each of the resonators R1B, R3B and R5B has a band characteristic similar to the characteristic shown in FIG. 40, and does not have any ripple in the pass band.

A description will now be given of the structure of the inductors L1, L2 and L3 shown in FIG. 13 according to a ninth embodiment of the present invention, with reference to FIG. 42, in which parts that are the same as parts shown in FIG. 16 are given the same reference numbers. As shown in FIG. 42, zigzag microstrip lines 220 and 221 are formed on the ceramic package 81 and are connected to the terminals 84₋₃ and 84₋₅. Ends of the microstrip lines 220 and 221 are connected to the ground. The pattern width of each of the microstrip lines 220 and 221 is 100 μm, and the distance between the microstrip lines 220 and 221 and the ground is 0.5 mm. When the dielectric constant of the ceramic package 81 is equal to 9, the inductance values of the microstrip lines 220 and 221 are equal to 2 nH.

A description will now be given, with reference to FIG. 43, of a tenth embodiment of the present invention which is another structure of the inductors L1, L2 and L3. In FIG. 43, parts that are the same as parts shown in FIG. 16 are given the same reference numbers as previously. Two zigzag microstrip lines 230 and 231 respectively connected to the resonators R1 and R2 are formed on the filter chip 82. Terminals 85₋₃ and 85₋₅ are connected to ends of the microstrip lines 230 and 231. Each of the microstrip lines 230 and 231 is 3000 Å thick, 60 μm wide and 2 mm in length. When the dielectric constant of the filter chip (LiTaO₃) 82 is equal to 44, the inductance of the microstrip lines 230 and 231 are equal to 2.2 nH.

It is possible to form inductors by suitably combining the bonding wire 86₋₃, the microstrip line 220 on the ceramic package 81 and the microstrip line 230 on the filter chip 82.

A description will now be given, with reference to FIG. 44, of a SAW filter 240 according to an eleventh embodiment of the present invention. The eleventh embodiment of the present invention is configured as follows. First, the resonance frequency f_{rs} of the resonators in the series arm is made higher than the antiresonance frequency f_{ap} of the resonators in the parallel arms in order to increase the pass band width. Second, $\Delta f \equiv f_{rs} - f_{ap}$ is selected so that the pass band does not have an extremely large loss.

The previously described embodiments of the present invention require that $f_{ap} = f_{rs}$. However, as long as this condition is maintained, the pass band cannot be increased.

In order to increase the pass band, the present inventors considered a condition $f_{ap} < f_{rs}$, as shown in FIGS. 46A and 46B. It is apparent from FIGS. 46A and 46B that $bx < 0$ within a range $f_{ap} < f < f_{rs}$ and hence this frequency range is changed to an attenuation band according to the aforementioned theory. However, in practice, the product bx can be maintained at a very small value by limiting $\Delta f = (f_{rs} - f_{ap})$, and the above frequency range can practically function as a pass band without any substantial attenuation.

FIGS. 47A, 47B and 47C show band characteristics of a ladder-type filter obtained when the $\Delta f = (f_{rs} - f_{ap})$ increases from zero. The filter used in the experiment has a piezoelectric substrate made of LiTaO_3 having an electromechanical coupling coefficient of 0.05, and an Al interdigital electrode having a film thickness of 3000 Å. The structure of the electrode is one of two basic units connected so as to form a ladder-type structure, as shown in FIG. 44. Each of the basic units comprises a first resonator in the parallel arm and a second resonator in the series arm. In order to form the input and output parts of the filter in symmetry to each other, a third resonator is provided in another parallel arm of the final stage. A plurality of basic units are cascaded so as to form a ladder-type structure in order to increase the side lobe suppression factor to a practical value.

However, the insertion loss increases as the number of basic units to be cascaded increases. Hence, it is preferable to determine the number of basic units to be cascaded, taking into account an actual filter specification. The filter being considered is intended to realize a loss equal to or less than 2 dB and a side lobe suppression factor equal to or higher than 20 dB. The interdigital electrode of each of the resonators in the parallel and series arms is designed to have an aperture length of 180 μm and 50 finger pairs. The ratio $P = (C_{op}/C_{os})$ obtained when C_{op} and C_{os} are electrostatic capacitances of parallel-arm and series-arm, respectively, is 1 because the electrodes of all the resonators have identical specifications.

FIG. 47A shows a band characteristic when $\Delta f = 0$. FIG. 47B shows a band characteristic when $\Delta f = 10$ MHz. The band characteristic shown in FIG. 47B is improved so that the pass band width (in which a loss equal to or less than 2.5 dB is ensured) is increased to 40 MHz, while the band characteristic shown in FIG. 47A has a pass band width of 22 MHz. It can be seen from FIGS. 47A and 47B that the pass band width is improved particularly for low frequencies. Further, the band characteristic shown in FIG. 47B has an improved side lobe suppression factor. More particularly, the side lobe suppression factor is improved to 20 dB from 19 dB.

There is a limit regarding improvement due to increase in Δf . FIG. 47C shows a band characteristic when $\Delta f = 19$ MHz. The pass band width slightly deteriorates at high frequencies, and this deterioration is approximately equal to 2.5 dB, which will increase the ripple in the pass band. In FIG. 47C, a ripple amounting to approximately 1.0 dB, which is the allowable ripple limit, is observed. When Δf is further increased, the insertion loss and the in-band ripple increase. Hence, an increase of $\Delta f = 19$ MHz is the limit.

The product bx obtained when $\Delta f = 19$ MHz was examined. In the experiment, a SAW resonator provided in a parallel arm shown in FIG. 44 and a SAW resonator provided in a series arm shown therein were separately fabricated. The admittance of the resonator in the parallel arm was measured by means of a circuit configuration shown in FIG. 48A, and the impedance of the resonator in the series arm was measured by means of a circuit configuration shown in FIG. 48B. The measurement of admittance and

impedance was carried out by measuring S_{21} by means of a network analyzer. The measured values of S_{21} were inserted into equations shown in FIGS. 48A and 48B, and the impedance Z_p and the admittance Y_p were calculated.

A frequency characteristic shown in FIG. 49 was obtained, which shows the imaginary part of the admittance or impedance, that is, the value of b or x . The frequency dependence of the product bx is as shown in FIG. 50. It can be seen from FIG. 50 that the product bx is negative and is a small value within $f_{ap} < f < f_{rs}$. The maximum absolute value $|bx_{max}|$ of the product bx is given when:

$$f = \sqrt{f_{ap} \cdot f_{rs}}$$

and was equal to 0.06 for the embodiment being considered. That is, when value $|bx_{max}|$ is equal to or smaller than 0.06, and deterioration of the insertion loss can be reduced and the in-band ripple can be suppressed to 1 dB or less. If $\Delta f > 19$ MHz, the value of $|bx_{max}|$ increases, and both the insertion loss and the in-band ripple will increase to 1 dB or greater. This value is not practical. As a result, the value of $|bx_{max}|$ is an upper-limit indicator of characteristic deterioration, and determines the allowable value of Δf .

The above consideration will be generalized. FIG. 51 is an equivalent circuit diagram of a ladder-type filter obtained by approximating the SAW resonators by the double resonance circuits of LC. The impedance Z_s of the SAW resonator in the series arm and the admittance Y_p of the SAW resonator in the parallel arm are expressed as follows:

$$Z_s = jx \quad (11)$$

$$= [-j(\omega_{rs}^2 - \omega^2)] / [C_{os}(\omega_{as}^2 - \omega^2)]$$

$$Y_p = jb \quad (12)$$

$$[= [jC_{op}(\omega_{ap}^2 - \omega^2)] / (\omega_{rp}^2 - \omega^2)]$$

$$= [-jC_{op}(\omega_{ap}^2 - \omega^2)] / (\omega_{as}^2 - \omega^2)$$

where ω_{rs} , ω_{as} , ω_{rp} , ω_{ap} are respectively the resonance and antiresonance frequencies of the series-arm resonator and the resonance and antiresonance frequencies of the parallel-arm resonator, and τ is the capacitance ratio (inherent in the substrate). The above resonance and antiresonance frequencies as well as the capacitance ratio are written as follows:

$$\omega_{rs} = 2\pi f_{rs} = 1 / \sqrt{C_{1s}L_{1s}\lambda}$$

$$\omega_{as} = 2\pi f_{as} = \omega_{rs} \sqrt{1 + 1/\tau}$$

$$\omega_{rp} = 2\pi f_{rp} = 1 / \sqrt{C_{1p}L_{1p}}$$

$$\omega_{ap} = 2\pi f_{ap} = \omega_{rp} \sqrt{1 + 1/\tau}$$

$$\tau = C_{0s}/C_{1s} = C_{0p}/C_{1p}$$

The product bx is calculated from the equations (11) and (12) as follows:

$$bx = -[C_{op}(\omega_{ap}^2 - \omega^2)(\omega_{rs} - \omega^2)] / [C_{os}(\omega_{rp}^2 - \omega^2)(\omega_{as}^2 - \omega^2)] \quad (13)$$

The angular frequency ω which makes the product bx have a pole is obtained from $\delta(bx)/\delta\omega=0$, and is expressed as follows:

$$= \sqrt{\omega_{ap} \cdot \omega_{rs}} \quad (14)$$

The value obtained by inserting the above into the equation (13) is the maximum value of the product bx in the pass band. That is,

$$bx_{max} = -[C_{0p} \cdot (1+1/\tau)] [C_{0s} \cdot \{1+1/(\tau \cdot \Delta\omega/\omega_{rs})\}^{-2}] \quad (15)$$

where

$$\Delta\omega = \omega_{rs} - \omega_{ap} = 2\pi \cdot \Delta f \quad (16)$$

FIG. 52 shows a relation between bx_{max} and $\Delta f/f_{rs}$ obtained by plotting the equation (15) as a parameter $P = C_{0p}/C_{0s}$. The hatched area shown in FIG. 52 corresponds to the condition such that the allowable value of the product bx is equal to or smaller than 0.06 obtained by the experiment. Hence, the allowable value α of $\Delta f/f_{rs}$ dependent on $P = C_{0p}/C_{0s}$ can be determined, and is written as follows, by inserting $|bx_{max}| = 0.06$ into the equation (15):

$$\alpha = 1 / [\sqrt{P(\tau^2 + \tau)/0.06} - \tau] \quad (17)$$

The capacitance ratio τ depends on the substrate material, and is approximately 15 for 36° Y-cut X-propagation LiTaO₃ according to the experiment. Hence, the equation (17) can be rewritten as follows:

$$\alpha = 6.67 \times 10^{-2} / (4.22\sqrt{P}-1) \quad (18)$$

When $P=1$, then $\alpha=0.02$, and $\Delta f=19$ MHz for the embodiment shown in FIG. 47 having f_{rs} of 948 MHz. That is, the equation (18) stands.

An increase in Δf is effective for a piezoelectric substrate material having a small capacitance ratio τ , that is a substrate material having a large electromechanical coupling coefficient. The equation (17) is obtained for such a substrate material.

The capacitance ratio τ is proportional to the reciprocal of the electromechanical coupling coefficient k^2 . The value of the ratio τ for 64° Y-cut X-propagation LiNbO₃ ($k^2=0.11$) and the value of the ratio τ for 41° Y-cut X-propagation LiNbO₃ are respectively 6.8 and 4.4. The above values are obtained using the τ value of 36° Y-cut X-propagation LiTaO₃ and $k^2=0.05$ (see K. Yamanouchi et al., "Applications for Piezoelectric Leaky Surface Wave", 1990 ULTRASONIC SYMPOSIUM Proceedings, pp.11–pp.18, 1990).

FIG. 53 shows the relation between the capacitance ratio τ and the electromechanical coupling coefficient k^2 , which is obtained using the values of k^2 and τ of 36° Y-cut X-propagation LiTaO₃ and using such a relation that k^2 is proportional to the reciprocal of τ .

From the relation shown in FIG. 53, the values of the capacitance ratios τ of 64° and 41° Y-cut X-propagation LiNbO₃ substrates can be obtained and are equal to 6.8 and 4.4, respectively.

The structure of the embodiment shown in FIGS. 44 and 45 will now be described. The SAW filter 240 comprises a 36° Y-cut X-propagation LiTaO₃ substrate 241, and has dimensions of 1.5 mm×2 mm×0.5 mm. From the input side

of the filter 240, a parallel-arm resonator Rp1, a series-arm resonator Rs1, a parallel-arm resonator Rp2, a series-arm resonator Rs2, and a parallel-arm resonator Rp3 are arranged in that order. Each of the resonators has reflectors (short-circuit type) 242 respectively provided on both sides of the electrode having an aperture length of 180 μm and 50 finger pairs. Each of the reflectors 242 has 50 finger pairs.

The parallel-arm resonators are the same as the series-arm resonators except for the periods of the interdigital electrodes. The period λ_p of the electrode of each parallel-arm resonator is 4.39 μm (the ratio between the pattern width and the gap is 1:1 and hence the pattern width is approximately 1.1 μm ($=\lambda_p/4$), and the period of the electrode of each series-arm resonator is 4.16 μm (the pattern width is 1.04 μm ($=\lambda_s/4$)).

The respective periods are selected using the following equations so that the resonance frequencies (f_{rp} , f_{rs}) of the respective resonators are equal to the respective predetermined values ($f_{rp}=893$ MHz, $f_{rs}=942$ MHz):

$$\lambda_s = V_m / f_{rs}$$

$$\lambda_p = V_m / f_{rp}$$

where V_m is the sound velocity of the surface wave propagating in the 36° Y-cut X-propagation LiTaO₃ crystal for an electrode thickness of 3000 Å, and is experimentally 3920 m/s.

The SAW filter 240 having the above structure has a band-pass characteristic having a broad pass band and a low loss, as shown in FIG. 47C, in which $\Delta f=19$ MHz. When only the pattern width λ_p in FIG. 45 is changed to 4.35 μm , then Δf becomes 10 MHz, and the characteristic shown in FIG. 47B is obtained. The electrode is made of an Al-Cu alloy and is 3000 Å thick, and is arranged so that the surface wave is propagated in the X direction of the piezoelectric substrate 241.

A description will now be given of piezoelectric substrates other than 36° Y-cut X-propagation LiTaO₃. The capacitance ratio τ of 64° Y-cut X-propagation LiNbO₃ is 6.8, and an equation corresponding to the equation (17) is written as follows:

$$\alpha = 1.47 \times 10^{-1} / (4.37\sqrt{P}-1) \quad (19)$$

The capacitance ratio τ of 41° Y-cut X-propagation LiNbO₃ is 4.4, and an equation corresponding to the equation (17) is written as follows:

$$\alpha = 2.273 \times 10^{-1} / (4.52\sqrt{P}-1) \quad (20)$$

As the τ value decreases, that is, the electromechanical coupling coefficient increases, α increases, and the characteristic deteriorates little even if Δf increases.

A description will now be given of a twelfth embodiment of the present invention with reference to FIGS. 54 through 57. A SAW filter 250 according to the twelfth embodiment of the present invention is a ladder-type SAW filter having a plurality of basic units (unit sections), each having a SAW resonator in the parallel arm and a SAW resonator in the series arm, and establishes image impedance matching between adjacent unit sections in order to reduce a loss at each connection node. With the above arrangement, it becomes possible to reduce the insertion loss in the pass band.

The twelfth embodiment of the present invention was made with the following consideration. As shown in FIGS.

58A and 58B, a band-pass characteristic can be obtained by means of at least one parallel-arm resonator and at least one series-arm resonator. The ladder-type connection comprising one parallel-arm resonator and one series-arm resonator is the unit section of the filter.

It is desirable that the resonance frequency of the series-arm resonator be equal to or higher than the antiresonance frequency of the parallel-arm resonator. Two unit sections respectively shown in FIGS. 58A and 58B are available. The series arm of the unit section shown in FIG. 58A [series] serves as the input terminal, and the series arm of the unit section shown in FIG. 58B serves as the output terminal. A multi-stage connection comprising a plurality of unit sections is categorized into one of three types shown in FIGS. 59A, 59B and 59C. FIG. 59A shows an arrangement in which either the input or the output is a series arm and the other is a parallel arm (asymmetrical type). FIG. 59B shows an arrangement in which both the input and output are parallel arms (symmetrical type). FIG. 59C shows an arrangement in which both the input and output are series arms (symmetrical type).

The insertion loss of the multi-stage connection having n unit sections is n times that of the unit section, and the side lobe suppression factor thereof is also n times that of the unit section. Generally, the insertion loss increases, while the side lobe suppression is improved. Particularly when the insertion loss is approximately zero, the multi-stage connection is an effective means. However, the insertion loss will be larger than n times that of the unit section unless the impedance matching between the adjacent unit section is good. If the impedance matching is poor, power is reflected at the interfaces between adjacent unit sections (each of the interfaces 1-1'-n-n'). The reflection of power increases the insertion loss. When the power reflection occurring at an interface between adjacent unit sections is denoted by Γ , the loss is expressed as $n10\log(\Gamma)$. Hence, it is important to suppress increase in the insertion loss establishing an impedance match between adjacent unit sections and suppressing power reflection at each interface between two adjacent unit sections.

A descriptions will now be given of a method for matching the impedance of adjacent unit sections. As shown in FIG. 60, when two circuits 1 and 2, each having four different terminal constants (four parameters A, B, C and D of an F matrix), are connected to each other so that the impedance matching therebetween is established, the circuits are designed so that image impedances obtained by viewing the circuits 1 and 2 from an interface b-b' are equal to each other. An image impedance Z_{i1} obtained by viewing the circuit 1 from the impedance b-b' can be expressed as follows, using four terminal constants A_1, B_1, C_1 and D_1 of the circuit 1:

$$Z_{i1} = \sqrt{D_1 B_1 / C_1 A_1} . \quad (21)$$

Similarly, an image impedance Z_{i2} obtained by viewing the circuit 2 from the interface b-b' can be expressed as follows:

$$Z_{i2} = \sqrt{A_2 B_2 / C_2 D_2} . \quad (22)$$

The image impedances Z_{i1} and Z_{i2} are determined regardless of a load resistance (pure resistance) R_0 .

When the equations (21) and (22) are equal to each other, the following impedance matching condition can be obtained:

$$D_1 B_1 / C_1 A_1 = A_2 B_2 / C_2 D_2 \quad (23).$$

FIG. 61A shows a connection having poor impedance matching, and the condition of the equation (23) is not satisfied. The reflection factor Γ obtained by viewing the right circuit from the interface b-b' is expressed as follows:

$$\Gamma = (Z_s Y_p) / (2 + Z_s Y_p) \quad (24).$$

The values of the Z_s and Y_p of a practical element are not equal to zero, and hence the reflection factor Γ thereof is not zero.

In a connection shown in FIG. 61B, an image impedance Z_{i1} obtained by viewing the left circuit from the interface b-b' is obtained as follows, using the equation (21):

$$Z_{i1} = \sqrt{Z_s / Y_p (1 + Z_s Y_p)} . \quad (25)$$

An image impedance Z_{i2} obtained by viewing the right circuit from the interface b-b' can be obtained using the equation (22). It will be noted that $Z_{i2} = Z_{i1}$. Hence, the impedance matching is established, and the reflection factor Γ at the interface b-b' is zero. The above holds true for a connection shown in FIG. 61C.

A description will now be given of a method for cascading a plurality of unit sections in the manner shown in FIG. 61B or 61C. FIG. 62-(A) shows a circuit comprising n unit sections (n>2), in which the connection method shown in FIG. 61B and the connection method shown in FIG. 61C are alternatively employed. It will be seen from the above description that there is no reflection at each interface.

The circuit shown in (A) of FIG. 62 can be modified, as shown in (B) of FIG. 62, in which two resonators respectively in adjacent parallel nodes are integrated and two adjacent resonators in the series arm are also integrated. The series-arm resonator closest to the input of the filter has an impedance value half that of the resonators located inside the above series-arm resonator. Similarly, the parallel-arm resonator closest to the output of the filter has an admittance value half that of the resonators located inside the above parallel-arm resonator.

FIGS. 63A, 63B and 63C show configurations obtained by applying the above modifying method shown in FIG. 62 to the configurations shown in FIGS. 59A, 59B and 59C, respectively. More particularly, FIG. 63A shows an impedance matching method corresponding to the matching method shown in FIG. 59A, in which either the input or output of the filter is the series arm and the other is the parallel arm. In the configuration shown in FIG. 63A, the impedance of the series-arm resonator located at one end of the filter is half that of each inner series-arm resonator, and the admittance of the parallel-arm resonator located at the other end of the filter is half that of each inner parallel-arm resonator.

FIG. 63B shows an impedance matching method corresponding to the matching method shown in FIG. 59B. In the configuration shown in FIG. 63B, each of two parallel-arm resonators located at respective ends thereof has an admittance value half that of the inner parallel-arm resonator.

FIG. 63C shows an impedance matching method corresponding to the matching method shown in FIG. 59C. In the configuration shown in FIG. 63C, each of the two series-arm resonators located at respective ends thereof has an impedance value half that of the inner series-arm resonators.

A further description will now be given of the twelfth embodiment of the present invention based on the above-mentioned concept. The SAW filter 250 according to the twelfth embodiment has the equivalent circuit shown in FIG.

54, and the practical structure shown in FIG. 55. As shown in FIG. 54, it has three series-arm resonators Rs1, Rs2 and Rs3, and three parallel-arm resonators Rp1, Rp2 and Rp3. Each of the six resonators has an identical aperture length (90 μm), and an identical number of finger pairs (100). Each of the resonators has two short-circuit-type reflectors respectively located on two opposite sides of the interdigital electrode in order to increase Q. Each of the reflectors has approximately 100 finger pairs. The series-arm resonators Rs1, Rs2 and Rs3 have an identical finger period (λ_s) of 4.191 μm . The parallel-arm resonators Rp1, Rp2 and Rp3 have an identical finger period λ_p of 4.38 μm , which is different from the value of λ_s .

FIG. 64 shows a [conventional] comparative example of the SAW filter [related to the SAW filter] 250 according to the twelfth embodiment of the present invention as a related art. In each of the filters shown in FIGS. 54 and 64, the design specification of each series-arm SAW resonator indicated by impedance Z_s is such that the aperture length is 90 μm and the number of finger pairs is 100. The design specification of each parallel-arm SAW resonator indicated by admittance Y_p is the same as the above design specification. The piezoelectric substrate crystal is made of 36° Y-cut X-propagation LiTaO₃. On the crystal substrate, an interdigital pattern for each SAW resonator formed with an Al alloy pattern having a thickness of 3000 Å is provided.

Curve 251 of the solid line shown in FIG. 56 indicates the characteristic of the filter 250. Curve 252 of the broken line shown in FIG. 56 indicates the characteristic of the filter shown in FIG. 64. It can be seen from FIG. 56 that the filter 250 has an insertion loss less than that of the filter shown in FIG. 64, and particularly the insertion loss at both ends of the pass band in the filter 250 is greatly improved.

Curve 253 shown in FIG. 57 shows a band characteristic of [the conventional filter shown in FIG. 64, in which] such an embodiment that the number of finger pairs of only the parallel-arm resonator indicated by admittance Y_p is reduced from 100 to 80 to thereby reduce the value of the admittance Y_p . It can be seen from FIG. 57 that the insertion loss in the pass band is improved. It may be said that the insertion loss can be somewhat improved even by reducing the admittance of the resonator at the end of the filter by a quantity less than 1/2. The above holds true for impedance.

The embodiment based on the basic structure shown in FIG. 63A has been described. A variation in which a number of unit sections are provided at the center of the filter has the same advantages as the above embodiment.

A description will now be given, with reference to FIG. 65, of a SAW filter 260 according to a thirteenth embodiment of the present invention. The SAW filter 260 is based on the basic structure shown in FIG. 63B, and has the same insertion loss improvement as shown by the curve 251 in FIG. 56.

FIG. 66 shows a SAW filter 270 according to a fourteenth embodiment of the present invention. The filter 270 is based on the basic structure shown in FIG. 63C. The filter 270 has the same insertion loss improvement as shown by the curve 251 in FIG. 56.

FIGS. 67 and 68 show a SAW filter 280 according to a fifteenth embodiment of the present invention. The present embodiment is based on such a consideration that the insertion loss depends on a resistance component and a conductance component of the interdigital electrode. With the above in mind, the fifteenth embodiment is intended to reduce the resistance component of each series-arm resonator and reduce the conductance component of each parallel-arm resonator and to thereby reduce the total insertion loss of a filter in which resonators make a ladder-type connection.

Referring to FIG. 67, SAW resonators R_{s1} , R_{s2} and R_{s3} are provided in the series arm, and SAW resonators R_{p1} , R_{p2} and R_{p3} are provided in the respective parallel arms. The resonance frequency f_{rs} of each of the resonators in the series arm is different from the resonance frequency f_{rp} of each of the resonators in the parallel arms.

It will now be assumed that the admittance of each parallel-arm resonator is expressed as follows:

$$Y_p = g + j \cdot b \quad (26)$$

where g denotes a conductance component, and b denotes a susceptance. Further, it will be assumed that the impedance of each series-arm resonator is expressed as follows:

$$Z_s = r + j \cdot x \quad (27)$$

where r denotes a resistance component, and x denotes a reactance component.

Under the above assumptions, the frequency characteristics of g, b, r and x are as shown in FIG. 71. The susceptance component b (indicated by the dot chained line) of the admittance Y_p of the parallel-arm resonator has the largest value at the resonance frequency f_{rp} , at which the sign thereof changes from + to -. Further, the susceptance component b becomes zero at the antiresonance frequency f_{ap} , at which the sign thereof changes from - to +. The conductance component g (one-dot chain line) has the largest value is at the resonance frequency f_{rp} , and rapidly decreases and approaches zero. The value of the conductance component g assumes only the plus sign.

The reactance component x (indicated by the solid line in FIG. 71) of the impedance Z_s of the series-arm resonator becomes zero at the resonance frequency f_{rs} , and the largest value at the antiresonance frequency f_{as} . Further, the sign of the reactance component x changes from + to -, and approaches zero from the minus side in a range higher than f_{as} . The resistance component r gradually increases from zero to the largest value at the antiresonance frequency f_{as} , and then gradually decreases. The resistance component r assumes only the plus sign.

In order to obtain a filter characteristic, the antiresonance frequency f_{ap} of the parallel-arm resonator is equal to or slightly smaller than the resonance frequency f_{rs} of the series-arm resonator.

A graph depicted in the lower portion of FIG. 71 shows the band characteristic of the filter circuit. The pass band is formed around $f_{ap} \approx f_{rs}$, and the other frequency range serves as an attenuation range. It can also be seen from FIG. 71 that b and x are respectively zero around the center frequency of the pass band. Hence, the pass band characteristic of the filter is determined by only r and g, and the following is obtained:

$$S_{21} = 100 / (100 + r + 50r \cdot g + 2500 \cdot g) \quad (28).$$

Since $r > 0$ and $g > 0$, S_{21} becomes smaller than 1 as both r and g increase, and the insertion loss written as $20 \log_{10} |S_{21}|$ also increases. Hence, the insertion loss decreases as both r and g are closer to zero.

A description will now be given of a consideration concerning which part of the interdigital electrode is related to the resistance component r and the conductance component g. The above consideration takes into account a resistance r_1 inserted in the equivalent circuit shown in FIG. 5B. The resistance r_1 is the sum of the electric resistance

component of the interdigital electrode and an acoustic resistance component corresponding to an energy loss encountered while bulk waves generated from ends of the fingers are propagated inside the substrate. The resistance component resulting from emission of bulk waves is little dependent on the shape of the interdigital electrodes, and is hence proportional to the electric resistance r_1 of the interdigital electrode. Particularly, $r=r_1$ around the center frequency of $\omega=0$.

The conductance component g of the admittance of the parallel-arm resonator is proportional to the conductance $1/r_1$ of the electric resistance of the interdigital electrode.

The following equation is known:

$$r=l_s \cdot \rho_O / (N_s \cdot W \cdot t) \quad (29)$$

where ρ_O denotes the resistivity of the fingers of the interdigital electrodes, W denotes the width of each finger, t denotes the film thickness of each finger, l_s denotes the aperture length of the series-arm resonator, and N_s denotes the number of finger pairs.

The conductance component g is obtained as follows if the same substrate and the same metallic film as those used in the series-arm resonator are employed:

$$g=N_p \cdot W \cdot t / (l_p \cdot \rho_O) \quad (30)$$

where l_p denotes the aperture length of the parallel-arm resonator, and the N_p denotes the number of finger pairs. It will be noted that ρ_O , W and t in the parallel-arm resonator are almost the same as those in the series-arm resonator.

Hence, an increase in the insertion loss in the equation (28) is expressed as follows:

$$r+50r \cdot g+2500g=l_s \cdot \rho_O / (N_s \cdot W \cdot t)+50 \cdot (l_s/l_p) \cdot (N_p/N_s)+2500 \cdot N_p \cdot W \cdot t / (l_p \cdot \rho_O) \quad (31)$$

It can be seen from equation (31) that the insertion loss of the series-arm resonator becomes smaller as the aperture length l_s decreases and the number N_s of finger pairs increases, and that the insertion loss of the parallel-arm resonator becomes smaller as the aperture length l_p increase and the number N_p of finger pairs decreases. Particularly, the insertion loss can be effectively reduced when $l_s/l_p < 1$ and $N_p/N_s < 1$, that is, when the aperture length of the series-arm resonator is smaller than that of the parallel-arm resonator, and the number of finger pairs of the series-arm resonator is larger than the number of finger pairs of the parallel-arm resonator.

The reason for the above will now be described. In equation (31), $r=r_s$ (r_s : electric resistance of the series-arm resonator), and $g=1/r_p$ (r_p : electric resistance of the parallel-arm resonator), and therefore the following expression can be obtained:

$$r+50r \cdot g+2500g=r_s+50(r_s/r_p)+2500(1/r_p).$$

Hence, an increase in the insertion loss can be suppressed when $(r_s/r_p) < 1$, that is, $r_s < r_p$.

If l_s is too short, a loss resulting from diffraction of the surface wave takes place. If l_p is too long, a decrease in Q of the parallel-arm resonator due to resistance increase appears, and the side lobe suppression factor is deteriorated. Hence, there is a limit on l_s and l_p .

The equation (31) can be modified as follows:

$$r+50r \cdot g+2500g=l_s \cdot \rho_O / (N_s \cdot W \cdot t_s)+50 \cdot (l_s/l_p) \cdot (N_p/N_s)+(t_p \cdot t_s)+2500 \cdot N_p \cdot W \cdot t_p / (l_p \cdot \rho_O) \quad (32)$$

where t_s denotes the film thickness of the metallic film forming the interdigital electrode of the series-arm resonator, and t_p denotes the film thickness of the metallic film forming the interdigital electrode of the parallel-arm resonator. Hence, the insertion loss can be reduced when t_p/t_s .

It is possible to use resonators, each having two different metallic films having different resistivity values (ρ_{os} , ρ_{op}) and to arrange these resonators in the parallel and series arms, so that $\rho_{op}/\rho_{os} < 1$ can be satisfied. However, this is not practical in terms of mass productivity.

A further description will be given, with reference to FIGS. 67 and 68, of the fifteenth embodiment based on the above concept. A piezoelectric substrate 241 is formed of 36° Y-cut X-propagation LiTaO₃, and an electrode is made of Al and 3000 Å thick.

Conventionally, in each of the parallel and series arms, $l_s=l_p=90 \mu\text{m}$, and $N_p=N_s=100$. In the present embodiment, $l_s=45 \mu\text{m}$ and $N_s=200$ in the series arm, while $l_p=180 \mu\text{m}$ and $N_p=50$ in the parallel arm. That is, $l_p > l_s$, and $N_s > N_p$. Further, $l_s/l_p=0.25$, and $N_p/N_s=0.25$. The electrostatic C_O of the interdigital electrode based on the product of the number of finger pairs and the aperture length is kept constant.

In FIG. 69, solid line 281 indicates the characteristic of the present embodiment, and broken line 282 indicates the characteristic of the conventional filter. The conventional filter has an insertion loss of 2.5 dB, while the present embodiment has an insertion loss of 2.0 dB. That is, the insertion loss is improved by 0.5 dB, in other words, 25%. Further, since an increased number of finger pairs of the series-arm resonator is used, the breakdown power performance is improved, and the applicable maximum power is improved by 20%.

In the present embodiment, a diffraction loss appears when l_s is equal to or less than 30 μm , and them side lobe starts to deteriorate when l_p is equal to or larger than 300 μm . Hence, the l_s and l_p are limited to the above values. It can be seen from the above that the insertion loss in the pass band is improved by decreasing the electric resistance of the series-arm and increasing the electric resistance of the parallel arm (decreasing the conductance). It is also possible to use a parallel-arm resonator having a film thickness larger than that of the series-arm resonator. Even with this structure, it is possible to reduce the insertion loss in the pass band.

A description will now be given, with reference to FIG. 72, of a wave filter according to a sixteenth embodiment of the present invention. The wave filter (branching filter) shown in FIG. 72 comprises two SAW filters F1 and F2 having input terminals connected to a pair of common signal terminals TO via common nodes a and b. The SAW filter F1 has a pair of signal terminals T1, and the SAW filter F2 has a pair of signal terminals T2. A pair of signal lines l_h and l_c connects the nodes a and b to the SAW filter F1, and another pair of signal lines l_h and l_c connects the nodes a and b to the SAW filter

The SAW filter F1 comprises a series-arm SAW resonator Rso, and a parallel-arm SAW resonator Rp, which resonators are configured as has been described previously. The resonator Rso is connected to the common node a, and hence serves as a resonator of the first stage of the SAW resonator F1. A plurality of pairs, each pair of series-arm resonator and

parallel-arm resonator are cascaded in the SAW filter F1. The SAW filter F2 is configured in the same manner as the SAW filter F1.

The SAW filters F1 and F2 respectively have different band center frequencies. For example, the SAW filter F1 has a band center frequency f_1 of 887 MHz, and the SAW filter F2 has a band center frequency f_2 of 932 MHz. In this case, the frequency f_1 is lower than the frequency f_2 .

FIG. 73 is a Smith's chart of the wave filter shown in FIG. 72. In FIG. 72, P indicates the pass band of the wave filter. A indicates a low-frequency-side attenuation band, and B indicates a high-frequency-side attenuation band. It can be seen from FIG. 73 that the characteristic impedance of the circuit shown in FIG. 72 is equal to 50Ω , while the impedances of the attenuation bands A and B are greater than 50Ω . This means that the wave filter shown in FIG. 72 has the impedance characteristics of the respective band-pass filters.

A description will now be given, with reference to FIGS. 74 and 75, of a wave filter according to a seventeenth embodiment of the present invention. In FIG. 74, parts that are the same as parts shown in the previously described figures are given the same reference symbols.

As has been described previously, the SAW filters F1 and F2 satisfy the condition $f_1 < f_2$. If the SAW band-pass filters F1 and F2 have characteristics as shown in FIG. 75, the filter F1 is maintained in a high-impedance state within the pass band frequency band of the filter F2. In this case, there is no need to provide an impedance matching circuit M to the filter F1, and the same characteristic as the characteristic of the filter F2 alone can be obtained.

However, the filter F2 does not have a high impedance within the low-frequency attenuation band A thereof, and crosstalk may take place. Hence, it is necessary to increase the impedance within the low-frequency attenuation band A of the filter F2.

An impedance matching circuit M for increasing the impedance in the low-frequency attenuation band A thereof is connected between the nodes a and b and the filter F2. The impedance matching circuit M includes an inductor L, which is a high-impedance element for rotating the phase of signal. The inductor L has an inductance of, for example, 6 nH. The inductor L can be formed with, for example, a metallic strip line made of, for example, gold, tungsten, or copper, and formed on a glass-epoxy or ceramic substrate. The strip line formed on the glass-epoxy substrate has a width of 0.5 mm and a length of 11 mm, and the strip line formed on the ceramic substrate has a width of 0.2 mm and a length of 6 mm.

As shown in FIG. 75, the impedance matching circuit M provided for the filter F2 rotates the phase in the direction indicated by the arrow, and the impedance of the filter F2 in the low-frequency attenuation band A can be increased.

FIG. 76 shows a wave filter according to an eighteenth embodiment of the present invention. In FIG. 76, parts that are the same as parts shown in the previously described figures are given the same reference symbols. The wave filter shown in FIG. 76 can be obtained by connecting a capacitor C, which corrects the quantity of phase rotation of the inductor L, in series between the inductor L and the series-arm resonator Rso. There is a possibility that a suitable impedance matching may be not obtained by means of only inductor L. As shown in a Smith's chart shown in FIG. 77, the phase is rotated in the direction indicated by the arrow shown in FIG. 77 first, and is rotated by means of the inductor L second.

FIG. 78 shows a wave filter according to a nineteenth embodiment of the present invention. The filter F1 com-

prises the series-arm SAW resonator Rso and the parallel-arm SAW resonator Rp, which are connected so that the series-arm resonator is located at the first stage of the filter F1. The parallel-arm SAW resonator Rpo of the filter F is located at the first stage of the filter F. A line S for use in phase rotation is connected in series to the SAW filter F2. It is possible to increase the impedance of the filter F1 within the high-frequency attenuation band B thereof even by an arrangement such that only the filter F1 has the series-arm resonator of the first stage. In this case, the resonator of the first stage of the filter F2 is the parallel-arm resonator Rpo connected in parallel to the pair of common signal terminals T0, and the low-frequency attenuation band A of the filter F2 (corresponding to the pass band of the filter F1 does not have a high impedance. Hence, according to the present embodiment, the phase rotation line S is connected in series to the filter F2.

As shown in FIG. 79, the direction of phase rotation caused by the line S is opposite to the directions shown in FIGS. 75 and 77. However, as shown in FIG. 80, suitable matching of the filter F2 can be obtained. In this case, the length of the line S formed on the glass-epoxy substrate is approximately 25 mm, and the length of the line S formed on the ceramic substrate is approximately 26 mm.

A variation of the configuration shown in FIG. 78 can be made by providing the inductor L in the same manner as shown in FIG. 74. It is also possible to further provide the capacitor C in the same manner as shown in FIG. 76.

The band center frequencies f_1 and f_2 of the sixteenth through nineteenth embodiments of the present invention are not limited to 887 MHz and 932 MHz.

The present invention is not limited to the specifically disclosed embodiments, and variations and modifications may be made without departing from the scope of the present invention.

What is claimed is:

1. A band-pass filter having a pair of band-pass filter [input] *common signal* terminals and plural pairs of band-pass filter [output] *signal* terminals, comprising:

a pair of [SAW] *band-pass* filters having respective pass bands and comprising a plurality of [one-port SAW] *acoustic wave* resonators connected in a *multiple* ladder structure, each having at least a first stage located at a side of the pair of band-pass filter [input] *common signal* terminals and [a series-arm resonator located at the first stage,] a pair of input terminals and a pair of output terminals;

the pair of band-pass filter [input] *common signal* terminals being commonly connected to the [respective pairs of input terminals of the pair] *pair* of [SAW] *band-pass* filters;

the plurality of pairs of band-pass filter [output] *signal* terminals being *respectively* connected to the [respective pairs of output terminals of the pair] *pair* of [SAW] *band-pass* filters; and

an inductance element located between [at least] *one side of only* one of the [SAW] *band-pass* filters located at the first stage and [the pair of band-pass filter input terminals and directly connected between the respective pair of input terminals of the at least one of the SAW filters and thereby in parallel to said at least one of the SAW filters] *one of the common signal terminals, and no inductance element being located between the other of the band-pass filters and one of the common signal terminals.*

[2. A SAW filter comprising:

a plurality of first SAW resonators, each having a pair of terminals and a predetermined resonance frequency

(f_{rp}), said first SAW resonators being connected in respective, parallel arms of the SAW filter;

a plurality of second SAW resonators, each having a pair of terminals and a predetermined resonance frequency (f_{rs}) approximately equal to an antiresonance frequency (f_{ap}) of each of the first SAW resonators, said second SAW resonators being provided in series arms of the SAW filter; and

inductance elements respectively connected in series with the first SAW resonators in the parallel arms and formed of wires.]

[3. The SAW filter as claimed in claim 2, further comprising:

a package accommodating the first and second resonators and the inductance elements; and

lead terminals extending from interiorly of the package to exteriorly thereof, said wires of the inductance elements being bonded to said lead terminals.]

[4. A band-pass filter having a predetermined pass-band characteristic and comprising:

a plurality of SAW resonators connected in a ladder formation, said plurality of resonators being connected in respective serial arms and parallel arms; and

bonding inductance elements, said parallel arms of said ladder formation being connected to ground via respective said bonding inductance elements.]

[5. The band-pass filter as claimed in claim 4, wherein said bonding inductance elements comprise wires.]

[6. A band-pass filter having a pair of band-pass filter input terminals and plural pairs of band-pass filter output terminals, comprising:

a pair of SAW filters having respective, different pass bands and each SAW filter having a pair of SAW filter input terminals and a pair of SAW filter output terminals and comprising a plurality of one-port SAW resonators connected in a ladder structure between the input and output terminals and including at least a first stage having a series-arm SAW resonator connected to one of the pair of input terminals;

a pair of SAW filters having respective pass bands and comprising a plurality of one-port SAW resonators connected in a ladder structure, each having at least a first stage located at a side of the pair of band-pass filter input terminals and a series-arm resonator located at the first stage, a pair of input terminals and a pair of output terminals;

the pair of band-pass filter input terminals being commonly connected to the respective pairs of input terminals of the pair of SAW filters;

the plurality of pairs of band-pass filter output terminals being connected to the respective pairs of output terminals of the pair of SAW filters.]

[7. A band-pass filter having a predetermined pass-band characteristic and comprising:

a plurality of SAW resonators connected in a ladder configuration of respective serial arms and parallel arms, said plurality of SAW resonators being connected in respective said serial arms and parallel arms; and

bonding inductance elements respectively connecting said parallel arms of said ladder configuration to ground.]

8. An acoustic wave filter comprising:

a first acoustic wave resonator having a pair of terminals and a predetermined resonance frequency (f_{rp}), said first acoustic wave resonator being provided in a parallel arm of the acoustic wave filter on a LiTaO_3 substrate; and

a second acoustic wave resonator having a pair of terminals and a predetermined resonance frequency (f_{rs}) approximately equal to a predetermined antiresonance frequency of the first acoustic wave resonator (f_{ap}), said second acoustic wave resonator being provided in a series arm of the acoustic wave filter on the LiTaO_3 substrate; and

an inductance element connected in series with the first acoustic wave resonator in the parallel arm, the inductance element functioning to increase the admittance of the parallel arm and decrease the resonance frequency, wherein

the first acoustic wave resonator comprises an exciting interdigital electrode and first and second reflectors, each of which comprises either aluminum or an aluminum alloy containing a few weight percentage of metal, other than aluminum; and

the respective film thicknesses of the exciting interdigital electrode and the first and second reflectors are in a range of from 0.06 to 0.09 times the period of the exciting interdigital electrode.

9. An acoustic wave filter comprising:

a first acoustic wave resonator having a pair of terminals and a predetermined resonance frequency (f_{rp}), said first acoustic wave resonator being provided in a parallel arm of the acoustic wave filter on a LiTaO_3 substrate; and

a second acoustic wave resonator having a pair of terminals and a predetermined resonance frequency (f_{rs}) approximately equal to a predetermined antiresonance frequency of the first acoustic wave resonator (f_{ap}), said second acoustic wave resonator being provided in a series arm of the acoustic wave filter on the LiTaO_3 substrate; and

an inductance element connected in series with the first acoustic wave resonator in the parallel arm, the inductance element functioning to increase the admittance of the parallel arm and decrease the resonance frequency, wherein

the first acoustic wave resonator comprises an exciting interdigital electrode and first and second reflectors, each of which comprises either gold or a gold alloy containing a few weight percentage of metal other than gold; and the respective film thicknesses of the exciting interdigital electrode and the first and second reflectors are in a range of from 0.0086 to 0.013 times the period of the exciting interdigital electrode.

10. An acoustic wave filter comprising:

a plurality of first acoustic wave resonators on a single piezoelectric substrate, each having a pair of terminals and a predetermined resonance frequency (f_{rp}), said first acoustic wave resonators being connected in respective, parallel arms of the acoustic wave filter;

a plurality of second acoustic wave resonators on the piezoelectric substrate, each having a pair of terminals and a predetermined resonance frequency (f_{rs}) approximately equal to the predetermined antiresonance frequency of the first acoustic wave resonator (f_{ap}), said second acoustic wave resonators being provided in a series arm of the acoustic wave filter; and inductance elements respectively connected to ground in series with the first acoustic wave resonators in the parallel arms.

11. A band-pass filter having a pair of band-pass filter common signal terminals and plural pairs of band-pass filter signal terminals, comprising:

31

a first band-pass filter having a pass band, having a band center frequency and comprising a plurality of acoustic wave resonators connected in a multiple ladder structure, having at least a first stage located at a side of the pair of band-pass filter common signal terminals, a pair of input terminals and a pair of output terminals;

a second band-pass filter having a different pass band from the pass band of the first band-pass filter, having a band center frequency which is larger than the band center frequency of the first band-pass filter and comprising a plurality of acoustic wave resonators connected in a multiple ladder structure, having at least a first stage located at a side of the pair of band-pass filter common signal terminals, a pair of input terminals and a pair of output terminals;

the pair of band-pass filter common signal terminals being commonly connected to the first and second band-pass filters;

the plurality of pairs of band-pass filter signal terminals being respectively connected to the first and second band-pass filters; and

only one impedance matching circuit located only between the first stage of the second band-pass filter and the common signal terminals.

12. The band-pass filter as claimed in claim 11, wherein the impedance matching circuit includes an inductor.

13. The band-pass filter as claimed in claim 12, wherein the inductor is formed with a metallic strip line.

14. The band-pass filter as claimed in claim 13, wherein the metallic strip line is formed on a ceramic package.

15. The band-pass filter as claimed in claim 11, wherein said impedance matching circuit includes an inductor and a capacitor.

16. A band-pass filter comprising:

a first band-pass filter having a pass band, having a band center frequency and comprising a plurality of acoustic wave resonators connected in a multiple ladder structure, having at least a first stage and a series-arm resonator located at the first stage, a pair of input terminals and a pair of output terminals;

a second band-pass filter having a different pass band from the pass band of the first band-pass filter, having a band center frequency which is larger than the band center frequency of the first band-pass filter and comprising a plurality of acoustic wave resonators connected in a multiple ladder structure, having at least a first stage and a parallel-arm resonator located at the first stage, a pair of input terminals and a pair of output terminals;

a pair of band-pass filter common signal terminals commonly connected to the first and second band-pass filters;

a plurality of pairs of band-pass filter signal terminals respectively connected to the first and second band-pass filters;

a circuit element used for phase rotation and connected between at least one of the pair of common signal terminals and the second band-pass filter.

32

17. The band-pass filter as claimed in claim 16, wherein the circuit element comprises a line formed on a glass-epoxy substrate or a ceramic substrate.

18. The band-pass filter as claimed in claim 16, wherein the circuit element comprises an inductance element.

19. The band-pass filter as claimed in claim 18, wherein the circuit element further comprises a capacitance element coupled to the inductance element.

20. A band-pass filter having a predetermined pass-band characteristic and comprising:

a plurality of acoustic wave resonators connected in a ladder formation, said plurality of resonators being connected in respective serial arms and parallel arms; and

bonding inductance elements, said parallel arms of said ladder formation being connected to ground via respective said bonding inductance elements, wherein:

a package in which the band-pass filter is mounted, contains a piezoelectric substrate and the ground; and the plurality of acoustic wave resonators are on the piezoelectric substrate.

21. A band-pass filter having a predetermined pass-band characteristic and comprising:

a plurality of acoustic wave resonators connected in a ladder formation, said plurality of resonators being connected in respective serial arms and parallel arms; and

bonding inductance elements, said parallel arms of said ladder formation being connected to ground via respective said bonding inductance elements, wherein:

a package in which the band-pass filter is mounted contains a piezoelectric substrate;

the plurality of acoustic wave resonators are on the piezoelectric substrate; and

a first electric resistance (R_s) of an interdigital electrode of a acoustic wave resonator provided in a series arm, is smaller than a second electric resistance (R_p) of an interdigital electrode of a acoustic wave resonator provided in a parallel arm which is next to the series arm.

22. A band-pass filter having a predetermined pass-band characteristic and comprising:

a plurality of acoustic wave resonators connected in a ladder formation, said plurality of resonators being connected in respective serial arms and parallel arms; and

bonding inductance elements, said parallel arms of said ladder formation being connected to ground via respective said bonding inductance elements, wherein:

the plurality of acoustic wave resonators are on a piezoelectric substrate; and

the bonding inductance elements are respectively connected to the ground outside the piezoelectric substrate.

* * * * *

UNITED STATES PATENT AND TRADEMARK OFFICE
CERTIFICATE OF CORRECTION

PATENT NO. : RE 40,036 E
APPLICATION NO. : 09/925942
DATED : January 29, 2008
INVENTOR(S) : Yoshio Satoh et al.

Page 1 of 1

It is certified that error appears in the above-identified patent and that said Letters Patent is hereby corrected as shown below:

On the title page item (63), Column 1 (Related U.S. Patent Documents), Line 2, change "Re. 37,390" to --Re. 37,790--.

Column 32, Line 36, before "acoustic" change "a" to --an--.

Column 32, Line 38, before "acoustic" change "a" to --an--.

Signed and Sealed this

Sixteenth Day of September, 2008

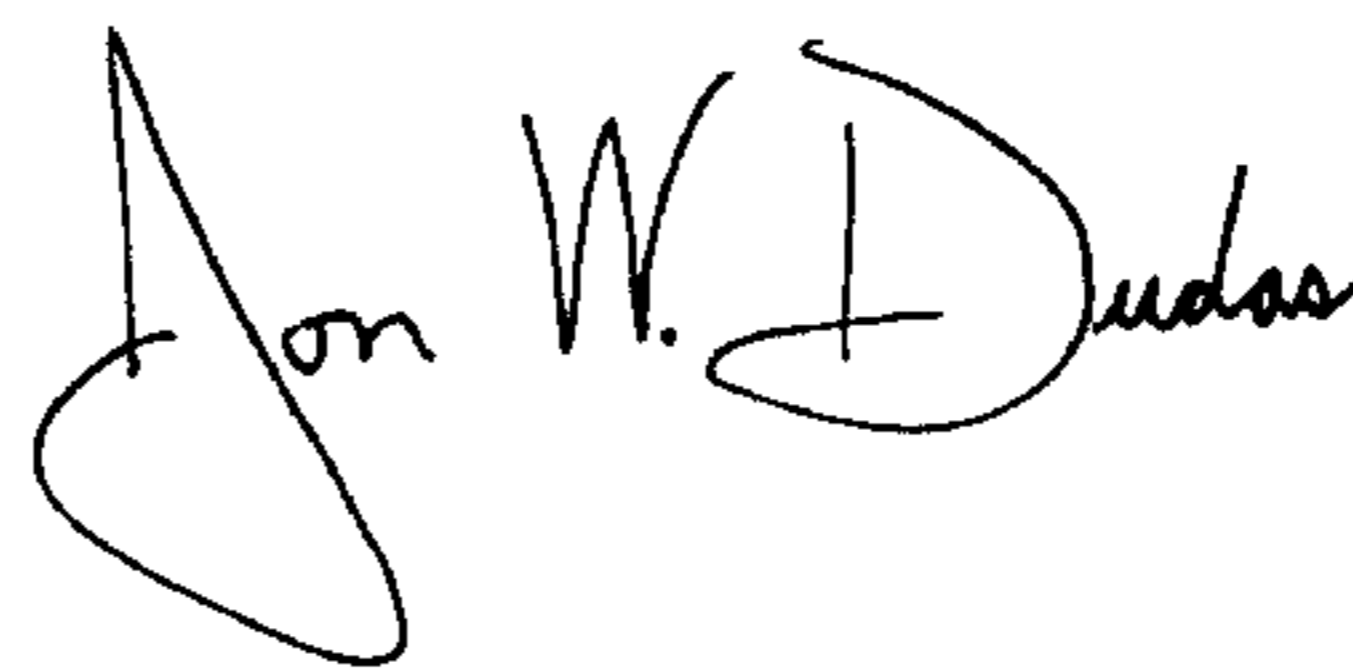
A handwritten signature in black ink that reads "Jon W. Dudas". The signature is written in a cursive style with a large, stylized initial "J".

JON W. DUDAS
Director of the United States Patent and Trademark Office